

# R&S®FSV3-K8

## Bluetooth® BR/EDR/LE

### Measurements

### User Manual



1179645002  
Version 03



This manual applies to the following FSW models with firmware version 6.00 and later:

- R&S®FSW8 (1331.5003K08 / 1312.8000K08)
- R&S®FSW13 (1331.5003K13 / 1312.8000K13)
- R&S®FSW26 (1331.5003K26 / 1312.8000K26)
- R&S®FSW43 (1331.5003K43 / 1312.8000K43)
- R&S®FSW50 (1331.5003K50 / 1312.8000K50)
- R&S®FSW67 (1331.5003K67 / 1312.8000K67)
- R&S®FSW85 (1331.5003K85 / 1312.8000K85)

The following firmware options are described:

- R&S FSV3-K8 (1346.5679.xx)

© 2024 Rohde & Schwarz

Muehldorfstr. 15, 81671 Muenchen, Germany

Phone: +49 89 41 29 - 0

Email: [info@rohde-schwarz.com](mailto:info@rohde-schwarz.com)

Internet: [www.rohde-schwarz.com](http://www.rohde-schwarz.com)

Subject to change – data without tolerance limits is not binding.

R&S® is a registered trademark of Rohde & Schwarz GmbH & Co. KG.

The Bluetooth® word mark and logos are registered trademarks owned by Bluetooth SIG, Inc. and any use of such marks by Rohde & Schwarz is under license.

All other trademarks are the properties of their respective owners.

1179.6450.02 | Version 03 | R&S®FSV3-K8

Throughout this manual, products from Rohde & Schwarz are indicated without the ® symbol, e.g. R&S®FSV3 is indicated as R&S FSV3.

# Contents

<b>1</b>	<b>Documentation overview.....</b>	<b>5</b>
1.1	Getting started manual.....	5
1.2	User manuals and help.....	5
1.3	Service manual.....	6
1.4	Instrument security procedures.....	6
1.5	Printed safety instructions.....	6
1.6	Specifications and brochures.....	6
1.7	Release notes and open-source acknowledgment (OSA).....	6
1.8	Application notes, application cards, white papers, etc.....	7
1.9	Videos.....	7
<b>2</b>	<b>Welcome to the R&amp;S FSV3 Bluetooth measurement application.....</b>	<b>8</b>
2.1	Key features.....	8
2.2	Starting the R&S FSV3 Bluetooth measurement application.....	9
2.3	Understanding the display information.....	10
<b>3</b>	<b>Measurement basics.....</b>	<b>12</b>
3.1	About Bluetooth BR/EDR/LE.....	12
3.2	About the Bluetooth BR/EDR/LE Modulation Characteristics measurement.....	28
3.3	About the Bluetooth BR/EDR/LE spurious emissions measurement.....	31
<b>4</b>	<b>Measurements and result displays.....</b>	<b>33</b>
4.1	Result displays for Modulation Characteristics measurements.....	34
4.2	Result displays for In-band Spurious Emissions measurements.....	40
<b>5</b>	<b>Configuration.....</b>	<b>44</b>
5.1	Configuration overview.....	44
5.2	Configuration according to digital standards.....	46
5.3	Input, output and frontend settings.....	47
5.4	Trigger settings.....	58
5.5	Gate settings.....	61
5.6	Modulation Characteristics measurement settings.....	63
5.7	In-band Spurious Emissions measurement settings.....	66
5.8	Sweep settings.....	68

5.9	Adjusting settings automatically.....	70
<b>6</b>	<b>Analysis.....</b>	<b>72</b>
6.1	Analyzing modulation characteristics.....	72
6.2	Analyzing in-band spurious emissions.....	83
6.3	Trace / data export configuration.....	90
6.4	Working with markers in the R&S FSV3 Bluetooth measurement application.....	92
6.5	Display configuration.....	98
<b>7</b>	<b>How to perform Bluetooth BR/EDR/LE measurements.....</b>	<b>99</b>
<b>8</b>	<b>Measurement examples.....</b>	<b>101</b>
8.1	Measurement example 1: Analyzing modulation accuracy for a basic Bluetooth signal.....	101
8.2	Measurement example 2: Analyzing in-band spurious emissions for a basic Bluetooth signal.....	104
<b>9</b>	<b>Remote commands to perform Bluetooth BR/EDR/LE measurements.....</b>	<b>106</b>
9.1	Introduction.....	107
9.2	Common suffixes.....	112
9.3	Activating Bluetooth BR/EDR/LE Measurements.....	112
9.4	Configuring Bluetooth BR/EDR/LE measurements.....	116
9.5	Performing a measurement.....	148
9.6	Analyzing Bluetooth BR/EDR/LE measurements.....	152
9.7	Configuring the result display.....	187
9.8	Retrieving results.....	195
9.9	Deprecated commands.....	199
9.10	Programming examples: Measuring Bluetooth BR/EDR/LE signals.....	202
	<b>Annex.....</b>	<b>205</b>
<b>A</b>	<b>Predefined standards and settings.....</b>	<b>205</b>
	<b>Glossary: Abbreviations.....</b>	<b>206</b>
	<b>List of commands (Bluetooth).....</b>	<b>208</b>

# 1 Documentation overview

This section provides an overview of the R&S FSV/A user documentation. Unless specified otherwise, you find the documents at:

[www.rohde-schwarz.com/manual/FSVA3000](http://www.rohde-schwarz.com/manual/FSVA3000)

[www.rohde-schwarz.com/manual/FSV3000](http://www.rohde-schwarz.com/manual/FSV3000)

Further documents are available at:

[www.rohde-schwarz.com/product/FSVA3000](http://www.rohde-schwarz.com/product/FSVA3000)

[www.rohde-schwarz.com/product/FSV3000](http://www.rohde-schwarz.com/product/FSV3000)

## 1.1 Getting started manual

Introduces the R&S FSV/A and describes how to set up and start working with the product. Includes basic operations, typical measurement examples, and general information, e.g. safety instructions, etc.

A printed version is delivered with the instrument. A PDF version is available for download on the Internet.

## 1.2 User manuals and help

Separate user manuals are provided for the base unit and the firmware applications:

- **Base unit manual**  
Contains the description of all instrument modes and functions. It also provides an introduction to remote control, a complete description of the remote control commands with programming examples, and information on maintenance, instrument interfaces and error messages. Includes the contents of the getting started manual.
- **Firmware application manual**  
Contains the description of the specific functions of a firmware application, including remote control commands. Basic information on operating the R&S FSV/A is not included.

The contents of the user manuals are available as help in the R&S FSV/A. The help offers quick, context-sensitive access to the complete information for the base unit and the firmware applications.

All user manuals are also available for download or for immediate display on the Internet.

## 1.3 Service manual

Describes the performance test for checking the rated specifications, module replacement and repair, firmware update, troubleshooting and fault elimination, and contains mechanical drawings and spare part lists.

The service manual is available for registered users on the global Rohde & Schwarz information system (GLORIS):

[R&S®FSVA3000/FSV3000 Service manual](#)

## 1.4 Instrument security procedures

Deals with security issues when working with the R&S FSV/A in secure areas. It is available for download on the internet.

## 1.5 Printed safety instructions

Provides safety information in many languages. The printed document is delivered with the product.

## 1.6 Specifications and brochures

The specifications document, also known as the data sheet, contains the technical specifications of the R&S FSV/A. It also lists the firmware applications and their order numbers, and optional accessories.

The brochure provides an overview of the instrument and deals with the specific characteristics.

See [www.rohde-schwarz.com/brochure-datasheet/FSV3000](http://www.rohde-schwarz.com/brochure-datasheet/FSV3000) /

[www.rohde-schwarz.com/brochure-datasheet/FSVA3000](http://www.rohde-schwarz.com/brochure-datasheet/FSVA3000)

## 1.7 Release notes and open-source acknowledgment (OSA)

The release notes list new features, improvements and known issues of the current software version, and describe the software installation.

The software uses several valuable open source software packages. An open source acknowledgment document provides verbatim license texts of the used open source software.

See [www.rohde-schwarz.com/firmware/FSV3000](http://www.rohde-schwarz.com/firmware/FSV3000) /  
[www.rohde-schwarz.com/firmware/FSVA3000](http://www.rohde-schwarz.com/firmware/FSVA3000)

## 1.8 Application notes, application cards, white papers, etc.

These documents deal with special applications or background information on particular topics.

See [www.rohde-schwarz.com/application/FSV3000](http://www.rohde-schwarz.com/application/FSV3000) /  
[www.rohde-schwarz.com/application/FSVA3000](http://www.rohde-schwarz.com/application/FSVA3000)

## 1.9 Videos

Find various videos on Rohde & Schwarz products and test and measurement topics on YouTube: <https://www.youtube.com/@RohdeundSchwarz>

## 2 Welcome to the R&S FSV3 Bluetooth measurement application

The R&S FSV3-K8 is a firmware application that adds functionality to perform Bluetooth BR/EDR/LE measurements to the R&S FSV/A.

This user manual contains a description of the functionality that the application provides, including remote control operation.

### General R&S FSV/A functions

The application-independent functions for general tasks on the R&S FSV/A are also available for Bluetooth BR/EDR/LE measurements and are described in the R&S FSV/A user manual. In particular, this comprises the following functionality:

- Data management
- General software preferences and information

The latest version is available for download at the product manuals homepage:

[www.rohde-schwarz.com/manual/FSV3000](http://www.rohde-schwarz.com/manual/FSV3000).

### Installation

You can find detailed installation instructions in the R&S FSV/A Getting Started manual or in the Release Notes.

## 2.1 Key features

The R&S FSV3 Bluetooth measurement application features:

- Acquisition and analysis of signals according to the Bluetooth standard, up to release 5.2
- Analysis of Basic Rate (BR), Enhanced data rate (EDR) and Low energy (LE) signals
- In-band spurious emission measurements in swept spectrum mode
- Modulation characteristics measurement in I/Q mode, including:
  - Automatic detection of packet type and packet length
  - Constellation
  - Demodulated waveform
  - Demodulated bitstream (symbols)
  - Frequency offsets
  - Frequency drift
  - ICFT
  - Output power
  - Adjacent channel power (ACP)



## 2.2 Starting the R&S FSV3 Bluetooth measurement application

Bluetooth BR/EDR/LE measurements are performed in a separate application on the R&S FSV/A.

### To activate the R&S FSV3 Bluetooth measurement application

1. Select [MODE].

A dialog box opens that contains all operating modes and applications currently available on your R&S FSV/A.

2. Select "Bluetooth".

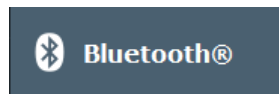

The R&S FSV/A opens a new channel for the R&S FSV3 Bluetooth measurement application.

The measurement is started immediately with the default settings. It can be configured in the Bluetooth BR/EDR/LE "Overview" dialog box, which is displayed when you select "Overview" from any menu (see [Chapter 5.1, "Configuration overview"](#), on page 44).

### Multiple Channels and Sequencer Function

When you activate an application, a new channel is created which determines the measurement settings for that application ("Channel"). The same application can be activated with different measurement settings by creating several "Channel"s for the same application.

The number of channels that can be configured at the same time depends on the available memory on the instrument.

Only one measurement can be performed at any time, namely the one in the currently active channel. However, to perform the configured measurements consecutively, a Sequencer function is provided.

If activated, the measurements configured in the currently defined "Channel"s are performed one after the other in the order of the tabs. The currently active measurement is indicated by a  symbol in the tab label.

The result displays of the individual channels are updated in the tabs (as well as the "MultiView") as the measurements are performed. Sequential operation itself is independent of the currently *displayed* tab.

For details on the Sequencer function, see the R&S FSV/A User Manual.

## 2.3 Understanding the display information

The following figure shows the result display during a basic Bluetooth in-band spurious emissions measurement. All different information areas are labeled. They are explained in more detail in the following sections.

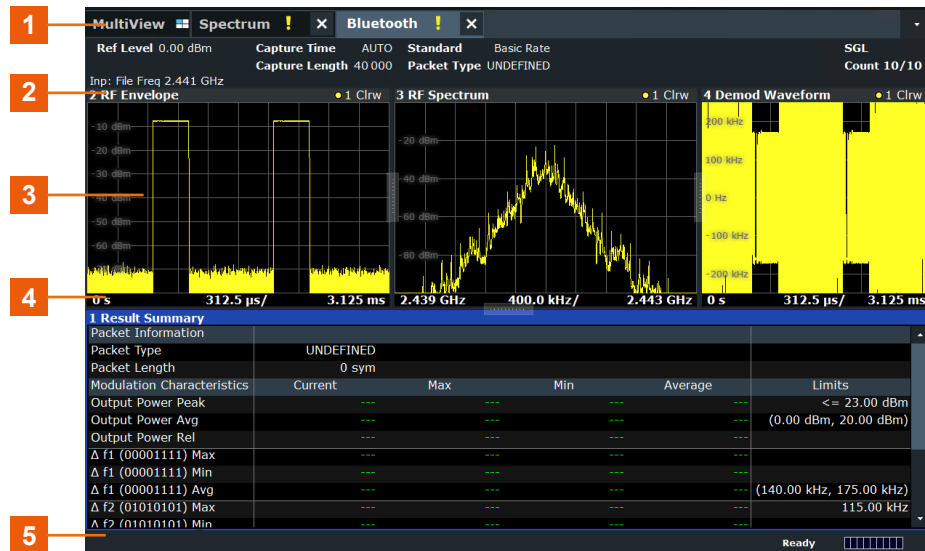

- 1 = Channel bar for firmware and measurement settings
- 2 = Diagram area
- 3 = Window title bar with diagram-specific (trace) information
- 4 = Diagram footer with diagram-specific information, depending on result display
- 5 = Instrument status bar with error messages and date/time display

### Channel bar information

In the R&S FSV3 Bluetooth measurement application, the R&S FSV/A shows the following settings:

**Table 2-1: Information displayed in the channel bar in the R&S FSV3 Bluetooth measurement application**

Label	Description
"Ref Level"	Reference level
"m.+el.Att"	Mechanical and electronic RF attenuation
"Offset"	Reference level offset
"Capture Time"	Data acquisition time
"Capture Length"	Number of captured samples per sweep
"Standard"	Selected Bluetooth standard
"Packet Type"	Detected packet type
	Sweep mode, e.g. "SGL" for single sweep
"Count"	Average sweep count

### Window title bar information

For each diagram, the header provides the following information:



*Figure 2-1: Window title bar information in the application for analog modulation analysis*

1 = Window number

2 = Window type

3 = Trace color

4 = Trace number

5 = Detector

### Diagram footer information

The diagram footer (beneath the diagram) indicates the displayed time or frequency range.

### Status bar information

Global instrument settings, the instrument status and any irregularities are indicated in the status bar beneath the diagram.

Furthermore, the progress of the current operation is displayed in the status bar.

## 3 Measurement basics

Some background knowledge on basic terms and principles used in Bluetooth BR/EDR/LE measurements is provided here for a better understanding of the required configuration settings.

### 3.1 About Bluetooth BR/EDR/LE

The frequency band defined for Bluetooth devices is the unlicensed 2.4 GHz Industrial, Scientific and Medical (ISM) frequency band.

Bluetooth specifies three operating modes. A time division duplex (TDD) scheme for duplex transmission is defined for all three modes.

- The mandatory **basic rate (BR)** uses binary FM modulation. It provides a data rate of 1 Mbps, and a symbol rate equal to 1 Msymbol/s.  
Up to 79 channels with a spacing of 1 MHz are available.
- The optional **enhanced data rate (EDR)** uses two types of PSK modulation, the  $\pi/4$ -DQPSK or 8DPSK, and achieves data rates of 2 Mbps and 3 Mbps, respectively.  
Both modulations schemes have a symbol rate equal to 1 Msymbol/s.  
Up to 79 channels with a spacing of 1 MHz are available.
- Bluetooth **Low Energy (LE)** provides data transfer from low-power devices running on the smallest of batteries to a larger device, such as a PC, a mobile phone, or a PDA. Bluetooth LE establishes a connection, e.g. to a wristwatch, a heart rate sensor, or a digital camera for data transfer.

Bluetooth Low Energy supports different transmission modes at the physical layer:

- **LE 1M**: uncoded, 1 symbol per data bit, 1 Msymbol/s data rate
- **LE 2M**: uncoded, 1 symbol per data bit, 2 Msymbol/s data rate
- **LE Coded**: 2 symbols per data bit, 1 Msymbol/s data rate  
For LE Coded, the header block of the packet contains a coding indicator, which defines the pattern mapping used by the subsequent payload block.

For LE 1M/Coded: up to 81 channels with a spacing of 1 MHz are available.

For LE 2M: Up to 40 communication channels with a spacing of 2 MHz are available.

**Table 3-1: Bluetooth characteristics**

Regulatory range	Operating mode	RF channels k and center frequencies f
2400.0 MHz to 2483.5 MHz	BR/EDR	$k = 0$ to 78, $f = k * 1 \text{ MHz} + 2402 \text{ MHz}$
	LE 1M/ LE Coded	$k = 0$ to 80, $f = k * 1 \text{ MHz} + 2402 \text{ MHz}$
	LE 2M	$k = 0$ to 39, $f = k * 2 \text{ MHz} + 2402 \text{ MHz}$

## Output power

The core specification of Bluetooth wireless technology defines the limits of output power levels at the maximum power. The minimum output power is limited to -20 dBm. The maximum output power for LE is limited to 10 dBm.

- [Bluetooth packet types for BR/EDR](#)..... 13
- [Bluetooth transport modes](#)..... 16
- [Packet structure and fields](#)..... 16
- [Bluetooth modulation schemes](#)..... 19
- [Packet formats for LE](#)..... 20
- [Packet types for LE](#)..... 20
- [Packet structure and fields](#)..... 22
- [Modulation scheme for LE](#)..... 24
- [Direction finding](#)..... 24

### 3.1.1 Bluetooth packet types for BR/EDR

#### 3.1.1.1 ACL packets

The ACL packets are used for asymmetric links and they contain user data or control data. The table and the figures below give an overview of the ACL packets and their structure.

*Table 3-2: ACL packet - basic rate*

Type	Payload Header (bytes)	User Payload (bytes)	FEC	CRC	Slot number
DM1	1	0-17	2/3	Yes, 16-bit	1
DH1		0-27	no		
DM3	2	0-121	2/3		3
DH3		0-183	no		
DM5		0-224	2/3		
DH5		0-339	no		
AUX1	1	0-29		no	5



*Figure 3-1: Packet structure of ACL packets - basic rate*

Table 3-3: ACL packets - enhanced rate

Type	Payload Header (bytes)	User Payload (bytes)	FEC	CRC	Slot number
2-DH1	2	0-54	no	Yes, 16-bit	1
2-DH3		0-367			3
2-DH5		0-679			5
3-DH1		0-83			1
3-DH3		0-552			3
2-DH5		0-1021			5



Figure 3-2: Packet structure of ACL packets - enhanced data rate

### 3.1.1.2 SCO and eSCO packets

The SCO and eSCO packets are used for symmetric links. The SCO packets are used for 64 kb/s speech transmission and for transparent synchronous data. The eSCO packets are also used for 64kb/s speech transmission and transparent data at 64 kb/s but also at other rates.

The tables and the figures below give an overview of the SCO and eSCO packets and their structure.

Table 3-4: SCO packets

Type	Payload Header (bytes)	User Payload (bytes)	FEC	CRC	Slot number
HV1	n.a.	10	1/3	no	n.a.
HV2		20	2/3		
HV3		30			
DV	1 (data only)	10+(0-9)	2/3 (data only)	Yes, 16-bit (data only)	



Figure 3-3: Packet structure SCO packets

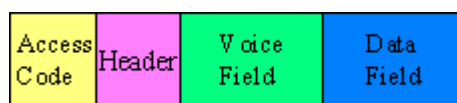

Figure 3-4: Packet structure SCO packets (data only)

Table 3-5: eSCO packets - basic rate

Type	Payload Header (bytes)	User Payload (bytes)	FEC	CRC	Slot number
EV3	n.a.	1-30	no	Yes, 16-bit (Data only)	1
EV4		1-120	2/3		3
EV5		1-180	no		3

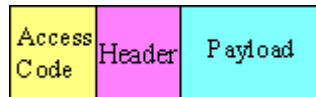

Figure 3-5: Packet structure eSCO packets - basic rate

Table 3-6: eSCO packets - basic rate

Type	Payload Header (bytes)	User Payload (bytes)	FEC	CRC	Slot number
2-EV3	n.a.	1-60	no	Yes, 16-bit	1
2-EV5		1-360			3
3-EV3		1-90			1
3-EV5		1-540			3



Figure 3-6: Packet structure eSCO packets - enhanced data rate

### 3.1.1.3 Link control packets for ACL, SCO, eSCO transport modes

There are some common kinds of packet types. An overview of these packet types is given in the table below.

Table 3-7: Common link control packets

Transport modes	Type	Payload Header (bytes)	FEC	CRC	Application
SCO, eSCO, ACL	ID	n.a.	n.a.	n.a.	Paging, inquiry, response
SCO, eSCO, ACL	NULL				Carries Link information to the source, e.g. about successfully received signal (ARQN) or the state of the receiving buffer (FLOW)
SCO, eSCO, ACL	POLL				Similar to NULL packet, used by the Central to poll the Peripheral devices, must be confirmed
SCO, ACL	FHS	18	2/3	Yes	Page Central response, inquiry response, in roll switch

Table 3-8: Common link control packets: packet structure

Packet Type ID	Packet Types NULL and PULL	Packet Types FHS
Access Code (DAK or IAC)	Access Code Header	Access Code Header Payload

### 3.1.2 Bluetooth transport modes

There are three different transport modes defined in the Bluetooth core specification, each of them with special applications:

- Synchronous connection-oriented (SCO)  
The SCO transport mode is used for a symmetric point-to-point link establishment between a Central and a specific Peripheral in the piconet.
- Extended synchronous connection-oriented (eSCO)  
The eSCO transport mode is used for a symmetric or asymmetric, point-to-point link establishment between the Central and a specific Peripheral.
- Asynchronous connection less (ACL)  
The ACL transport mode is used for a point-to-multipoint link establishment between the Central and all Peripheral participating on the piconet.

There are some common transmitted packets used by all transport modes and some specific packets defined for each transport mode.

### 3.1.3 Packet structure and fields

Almost all Bluetooth transmitted packets have standard format and consist of the access code, the header and the payload with useful information. The exceptions are the ID packet which consists of the access code only and NULL and POLL packets which carry only the access code and the header.

#### 3.1.3.1 Access code

The access code is used for synchronization, DC offset compensation and identification. The fields of the access code are shown in the figure below and their meaning is explained in the table below.

LSB 4	64	4 MSB
Preamble	Sync word	Trailer

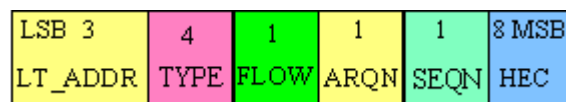

**Table 3-9: The access code fields**

Field	Description	Packets
Preamble	A fixed zero-one pattern of 4 symbols, used to facilitate DC compensation	All packets
Sync word	A 64-bit code word derived from a 24-bit address, improves timing acquisition	All packets
Trailer	A fixed zero-one pattern of four symbols, extended DC compensation	All packets, except ID

### 3.1.3.2 Header

The header contains link control information. The fields of the header are shown in the figure and their meaning is explained in the table below.

**Table 3-10: The header fields**

Field	Description	Packets
LT_ADDR	Logical transport address, indicates the destination Peripheral for a packet in a Central-to-Peripheral transmission slot and the source Peripheral for a Peripheral-to-Central transmission slot	
TYPE	Type code, specifies which packet type is used	
FLOW	Flow control, used for flow control of packets over the ACL logical transport. When the RX buffer in the recipient is full, a STOP indication must be returned. When the RX buffer can accept data, a "Go" indication must be returned.	All packets, except ID
ARQN	Automatic repeat request number, acknowledgement indication, used to inform the source of a successful transfer of payload data with CRC can be positive acknowledged ACK or negative acknowledged NAK,	
SEQN	Sequential numbering scheme to order the data packet stream	
HEC	Header-error-check to check the header integrity	

### 3.1.3.3 Payload format

The payload structure depends on the type of the data field and the data rate. Two fields are defined in the payload: the synchronous data field and the asynchronous data field. The ACL packets only have the asynchronous data field and the SCO and eSCO packets only have the synchronous data field. The exception is DV of SCO transport mode which has both data fields, synchronous and asynchronous.

**Synchronous data fields**

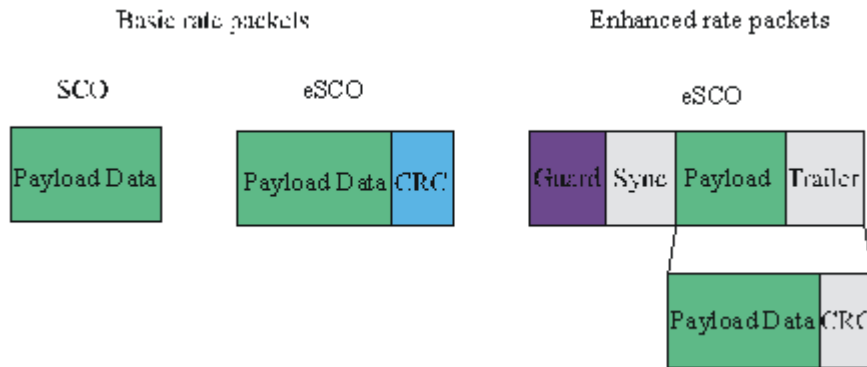

**Asynchronous data fields**

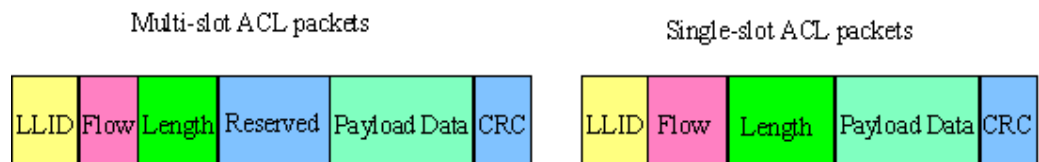

**Synchronous and asynchronous data fields**

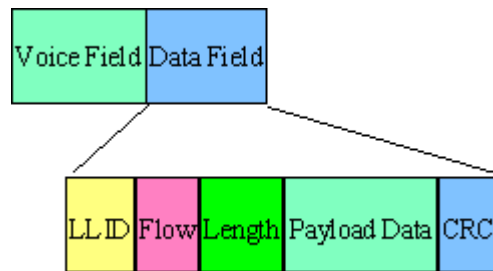

The meaning of some payload fields is given in the table below.

**Table 3-11: The payload fields**

Field	Description
CRC	The cyclic redundancy error check
Guard, sync	The guard time and synchronization sequence, used for physical layer change of modulation scheme
LLID	The logical link identifier, specifies the logical link
Flow	Field which controls the flow on the logical channels

The payload format and content of the FHS packet are different from other packets. The fields of the FHS packet are shown in the figure below and their meaning is explained in the table below.

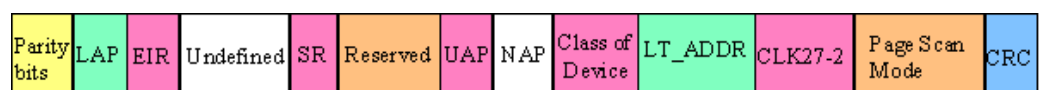

**Table 3-12: The payload fields for the FHS packet**

Field	Description
Parity bits	Form the first part of the sync word of the access code of the device that sends the FHS packet
LAP	Contains the lower address part of the device that sends the FHS packet
EIR	An extended inquiry response, provides miscellaneous information during the inquiry response procedure
Undefined	Reserved for future use and must be set to zero
SR	The scan repetition field, indicates the interval between two consecutive page scan windows
Reserved	Must be set to 10
UAP	Contains the upper address part of the device that sends the FHS packet
NAP	Contains the non-significant address part of the device that sends the FHS packet
Class of device	Contains the class of device of the device that sends the FHS packet. This field is defined in Bluetooth assigned numbers.
LT_ADDR	Contains the logical transport address
CLK27-2	Contains the value of the native clock of the device that sends the FHS packet, sampled at the beginning of the transmission of the access code of this FHS packet
Page scan mode	Indicates which scan mode is used by default by the sender of the FHS packet

### 3.1.4 Bluetooth modulation schemes

The modulation used for the basic data rate packets is GFSK (Gaussian Frequency Shift Keying) with a bandwidth bit period product  $BT = 0.5$ . The modulation index is between 0.28 and 0.35.

The modulation scheme used for enhanced data rate packets changes within the packet. The access code and packet header have a GFSK modulation scheme and are transmitted with the basic rate 1 Mbps. The subsequent synchronization sequence, payload and trailer sequence have a PSK type of modulation and are transmitted with a data rate of 2 Mbps or optionally 3 Mbps.

The PSK modulation, namely  $\pi/4$  rotated differential encoded quaternary phase shift keying ( $\pi/4$ -DQPSK) is defined for the 2 Mbps transmission.

The PSK modulation, namely differential encoded 8-ary phase shift keying (8DPSK), is defined for the 3 Mbps transmission.

The modulation types and corresponding packet types are given in the table below.

**Table 3-13: The modulation types and corresponding packet types**

Modulation type	Packet types
GFSK	ID, NULL, POLL, FHS, DM1, DH1, DM3, DH3, DM5, DH5, AUX1, HV1, HV2, HV3, DV, EV3, EV4, EV5
GFSK + $\pi/4$ -DQPSK	2-DH1, 2-DH3, 2-DH5, 2-EV3, 2-EV5
GFSK + 8DPSK	3-DH1, 3-DH3, 3-DH5, 3-EV3, 3-EV5

### 3.1.5 Packet formats for LE

#### Packet formats for LE uncoded PHY

The following packet format is defined for the LE uncoded PHYs and is used for both advertising channel packets and data channel packets.

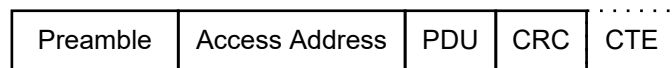
**Figure 3-7: LE uncoded PHY packet format**

Each packet consists of four mandatory fields: preamble, access address, PDU, and CRC. For Bluetooth [Direction finding](#), the optional field Constant Tone Extension (CTE) is added at the end.

**Table 3-14: Packet format for LE uncoded PHY**

Physical layer	Preamble	Access address	PDU	CRC	CTE
LE 1 Msymbol/s	1 octet	4 octets	2 to 257 octets	3 octets	16 $\mu$ s to 160 $\mu$ s

The preamble is transmitted first, followed by the access address, followed by the PDU followed by the CRC and optionally followed by CTE. The entire packet is transmitted at the same symbol rate.

Packets take between 44  $\mu$ s and 2120  $\mu$ s to transmit. The period extends by an additional 16  $\mu$ s to 160  $\mu$ s, if CTE is active.

### 3.1.6 Packet types for LE

#### Test packet types

The test packet PDU is subdivided into a PDU header and the payload field. The PDU header indicates the payload content type and the payload length expresses in octets. RFU field means reserved for future use.

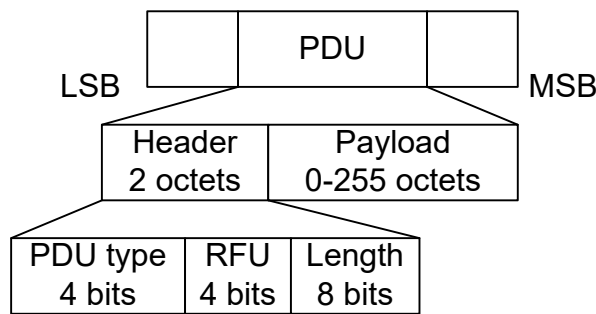

LE test packets are described in the "Air Interface Packets" section of core specification for Bluetooth wireless technology, volume 6, part B.

### Advertising channel packet types

The advertising channel PDU has a 16-bit header and a variable size payload. The header fields of the advertising channel PDU are as shown in [Chapter 3.1.3.2, "Header"](#), on page 17.

**Table 3-15: Advertising packet types:**

ADV_IND	SCAN_REQ
ADV_DIRECT_IND	SCAN_RSP
ADV_NONCONN_IND	CONNECT_IND
ADV_SCAN_IND	

### Data channel packet types

The data channel PDU has a 16-bit header, a variable size payload, and can include a message integrity check (MIC) field as shown in [Chapter 3.1.3.2, "Header"](#), on page 17.

The MIC field is not included in an unencrypted link layer (LL) connection. Nor in an encrypted LL connection with a data channel PDU with a zero length payload. The MIC field is included in an encrypted LL connection, with a data channel PDU with a non-zero length payload. The MIC calculation is specified in the section 1 of core specification for Bluetooth wireless technology, volume 6, part E.

Besides the data packet type, instrument supports the following CONTROL\_DATA packet types.

**Table 3-16: Control data packet types**

Opcode	CONTROL_DATA	Opcode	CONTROL_DATA
0x00	LL_CONNECTION_UPDATE_IND	0x07	LL_UNKNOWN_RSP
0x01	LL_CHANNEL_MAP_IND	0x08	LL_FEATURE_REQ
0x02	LL_TERMINATE_IND	0x09	LL_FEATURE_RSP
0x03	LL_ENC_REQ	0x0A	LL_PAUSE_ENC_REQ
0x04	LL_ENC_RSP	0x0B	LL_PAUSE_ENC_RSP

Opcode	CONTROL_DATA	Opcode	CONTROL_DATA
0x05	LL_START_ENC_REQ	0x0C	LL_VERSION_IND
0x06	LL_START_ENC_RSP	0x0D	LL_REJECT_IND

### 3.1.7 Packet structure and fields

#### 3.1.7.1 Advertising channel packet structure

##### Header

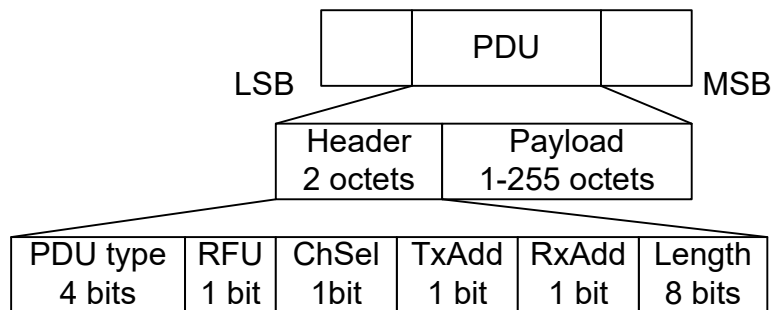

- The possible **PDU types**, indicated in the header of advertising channel PDU, are listed in the previous tables, see [Table 3-15](#).
- The **ChSel**, **TxAdd** and **RxAdd** fields contain information specific to the PDU type. If the ChSel, TxAdd or RxAdd fields are not defined as used in a given PDU then they are considered Reserved for Future Use.
- The **Length** field indicates the payload field length in octets.

##### Payload

The advertising channel PDU types can be divided into the following three groups.

**Table 3-17: Advertising channel PDU types**

Advertising PDUs	ADV_IND, ADV_DIRECT_IND, ADV_NONCONN_IND, ADV_SCAN_IND
Scanning PDUs	SCAN_REQ, SCAN_RSP
Initiating PDUs	CONNECT_IND

The following parameters are transmitted in the advertising PDU:

- **AdvA**, **AdvData** for ADV\_IND, ADV\_NONCONN\_IND and ADV\_SCAN\_IND
- **AdvA**, **TargetA** (formerly InitA) for ADV\_DIRECT\_IND

The following parameters are transmitted in the scanning PDU:

- **ScanA**, **AdvA** for SCAN\_REQ
- **AdvA**, **ScanRspData** for SCAN\_RSP

The following parameters are transmitted in the initiating PDU:

- **InitA, AdvA, LLData** for CONNECT\_IND
  - **LLData** contains
    - **AA, CRCinit, WinSize, WinOffset, Interval, Latency, Timeout, ChM, Hop,** and **SCA** fields

For more details, refer to in the section 2.3 Advertising Channel PDU of core specification for Bluetooth wireless technology, volume 6, part B.

### 3.1.7.2 Data channel packet structure

#### Header

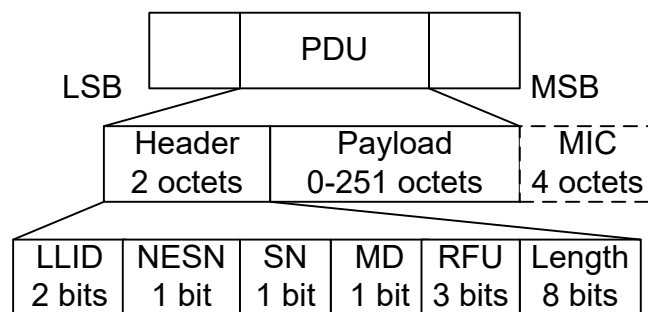

The 16-bit header field consists of five fields:

- The **LLID** field of the header specifies the payload format, refer to "[Payload](#)" on page 23.
- The **NESN** bit indicates a nextExpectedSeqNum used by the peer to acknowledge the last PDU sent, or to request resending.
- The **SN** bit indicates a transmitSeqNum to identify packets sent by the link layer.
- The **MD** bit indicates, whether the device has more data to send.
- The **Length** field indicates the length of the payload and MIC if included.

#### Payload

- An **LL data PDU** is used to send L2CAP data. The LLID field is set to either 01b or 10b.
  - For the LLID field set to 01b, the LL data PDU is a continuation fragment of an L2CAP message, or an empty PDU. The LL of the Central sends an empty PDU to the Peripheral to allow the Peripheral to respond with any data channel PDU, including an empty PDU.
  - For the LLID field set to 10b, the LL data PDU is a start of an L2CAP message or a complete L2CAP message with no fragmentation.
- An **LL control PDU** is used to control the LL connection. The payload consists of Opcode and CtrData fields. All LL control PDUs have a fixed length, depending on the Opcode. The Opcode field identifies different types of LL Opcode PDU, see [Table 3-16](#).

For more details, refer to the section 2.4 Data Channel PDU of the core specification for Bluetooth wireless technology, volume 6, part B.

### 3.1.8 Modulation scheme for LE

The modulation is Gaussian frequency shift keying (GFSK) with a bandwidth bit period product  $BT = 0.5$ . The modulation index has to be between 0.45 and 0.55. The mandatory modulation scheme is 1 Msymbol/s modulation. It uses a shaped, binary FM to minimize transceiver complexity.

### 3.1.9 Direction finding

Since Bluetooth version 5.1, a Bluetooth LE device can transmit its direction information to a Bluetooth receiver. The information is transmitted in direction finding enabled packets in the LE uncoded PHY. In combination with location information sent on profile-level, the Bluetooth LE receiver can calculate its position.

#### Angle of Arrival (AoA) method

A Bluetooth LE transmitter sends direction finding enabled packets using a single antenna. A receiving Bluetooth LE peer device consists of an antenna array linked to an RF switch which forwards the combined antennae signal to a Bluetooth LE receiver.

The peer device switches its antennae while receiving parts of the packets and capturing I/Q samples. The I/Q samples are used to calculate the phase difference of the radio signal received by different antennae of the array. For an array of two antennae with distance  $d$ , frequency  $f$  of the radio signal and speed of light  $c$ , the phase difference  $\psi$  calculates as follows:

$$\psi = 2\pi d * \cos(\Theta) * f / c$$

The angle of arrival  $\Theta$  is calculated as follows:

$$\Theta = \arccos((\psi * c) / (2\pi d * f))$$



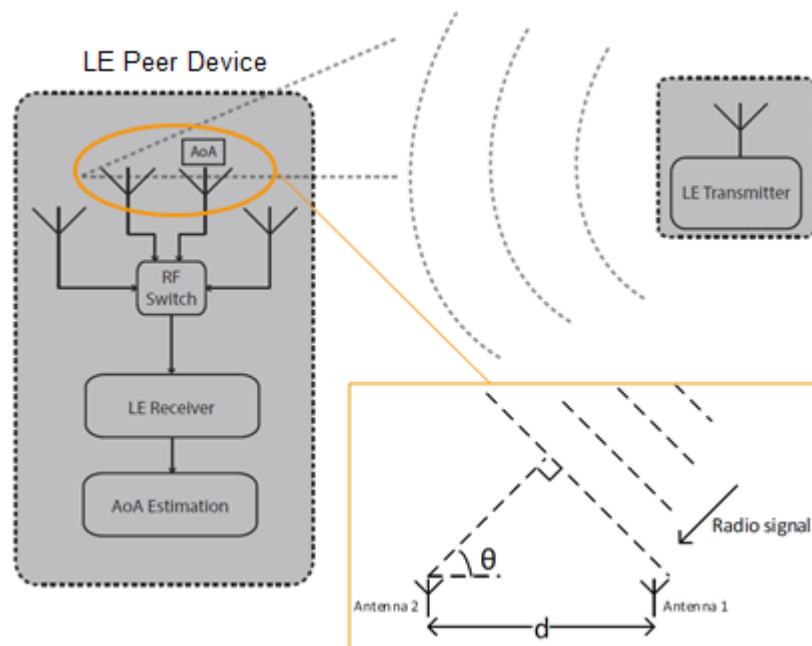

Figure 3-8: Angle of Arrival method

### Angle of Departure (AoD) method

A Bluetooth LE transmitter sends direction finding enabled packets using an antenna array. A receiving Bluetooth LE device, consisting of a single antenna, captures I/Q samples and the geometry of the antenna array from profile-level information.

For an array with two antennae with distance  $d$ , frequency  $f$  of the radio signal and speed of light  $c$ , the phase difference  $\psi$  calculates as follows:

$$\psi = 2\pi d \cdot \cos(\Theta) \cdot f / c$$

The angle of departure  $\Theta$  is calculated as follows:

$$\Theta = \arccos((\psi \cdot c) / (2\pi d \cdot f))$$

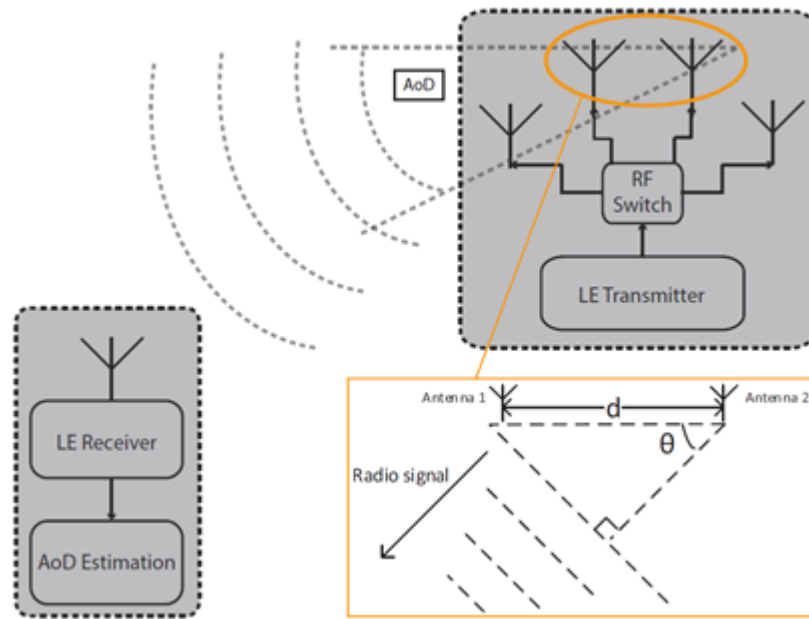

Figure 3-9: Angle of Departure method



The geometry of the antenna array is information that is shared between Bluetooth LE transmitter and receiver on a profile-level. The antenna switching pattern and the method of angle estimation is specified by Constant Tone Extension.

For more information, refer to section 8 Direction Finding Using Bluetooth Low Energy of core specification for Bluetooth wireless technology, volume 1, part A.

### Constant tone extension

To transmit direction finding information in packets in the Bluetooth LE Uncoded PHYs, the link layer packet format is extended by an optional field Constant Tone Extension (CTE) as illustrated in Figure 3-7. The field has a length between 16  $\mu$ s and 160  $\mu$ s and consists of a constantly modulated series of unwhitened 1s. This modulation results in a CW tone shifted by 250 kHz (LE1M) or 500 kHz (LE2M) from the LE channel center frequency.

The presence, type and length of CTE is specified in the CTEInfo field available for ADV\_SYNC\_IND and ADV\_CHAIN\_IND PDUs.

CTEInfo (8 bit)		
CTETime	RFU	CTEType

Figure 3-10: CTEInfo field

The parts of the CTEInfo field are described in the table below. CTEType specifies, if AoA or AoD method is used for direction finding.

CTEInfo field	Length	Value	Description
CTETime	5 bit	2 to 20	CTE length = $8 \mu\text{s} * \text{Value}$ Other values are reserved for future use.
RFU	1 bit	1 to 2	Reserved for future use
CTEType	2 bit	0	AoA Constant tone extension
		1	AoD Constant tone extension with $1 \mu\text{s}$ slots
		2	AoD Constant tone extension with $2 \mu\text{s}$ slots
		3	Reserved for future use

If Bluetooth LE devices support AoA/AoD CTE, the antennae within the array follow a switching pattern specified by the Host. After a guard and reference period, time slots of  $1 \mu\text{s}$  or  $2 \mu\text{s}$  provide periods for antenna switching and I/Q sampling.

The following figure illustrates the CTE structure for AoA method. On the transmitting side, there is no antenna switching. On the receiving side, antenna switching and I/Q sampling alternate in the time slots after the guard and reference period.

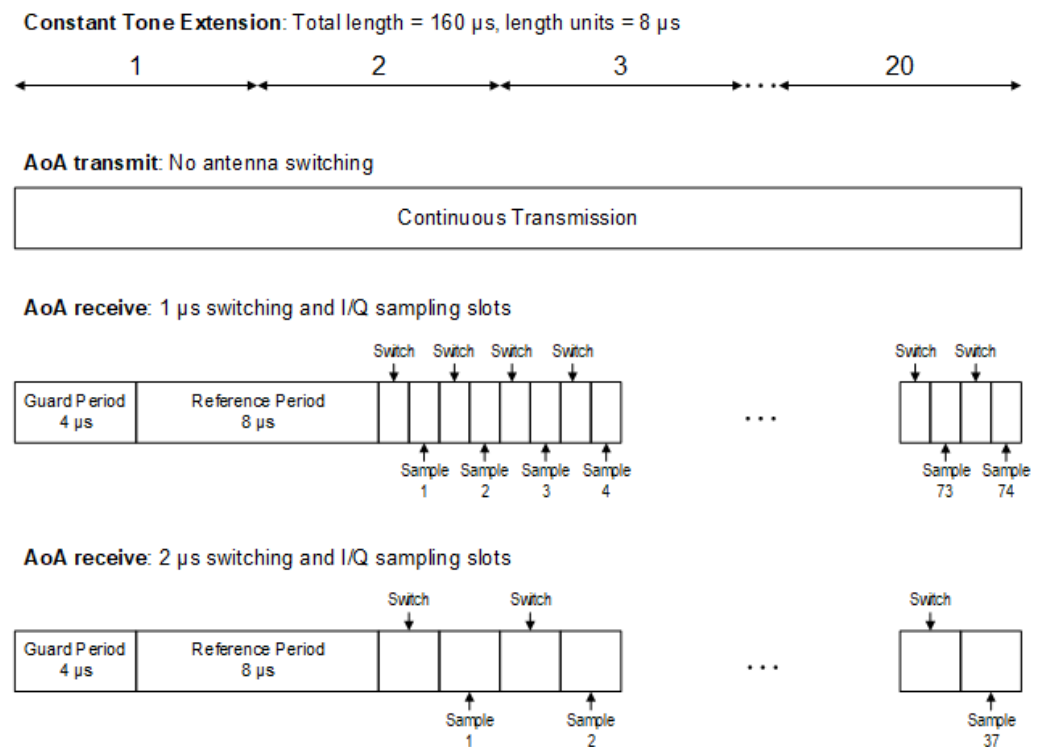

**Figure 3-11:** CTE structure for AoA method

The following figure illustrates the CTE structure for AoD method. On the transmitting side, antenna switching and I/Q sampling alternate in the time slots after the guard and reference period. On the receiving side, I/Q sampling only is performed in every second time slot after the guard and reference period.

About the Bluetooth BR/EDR/LE Modulation Characteristics measurement

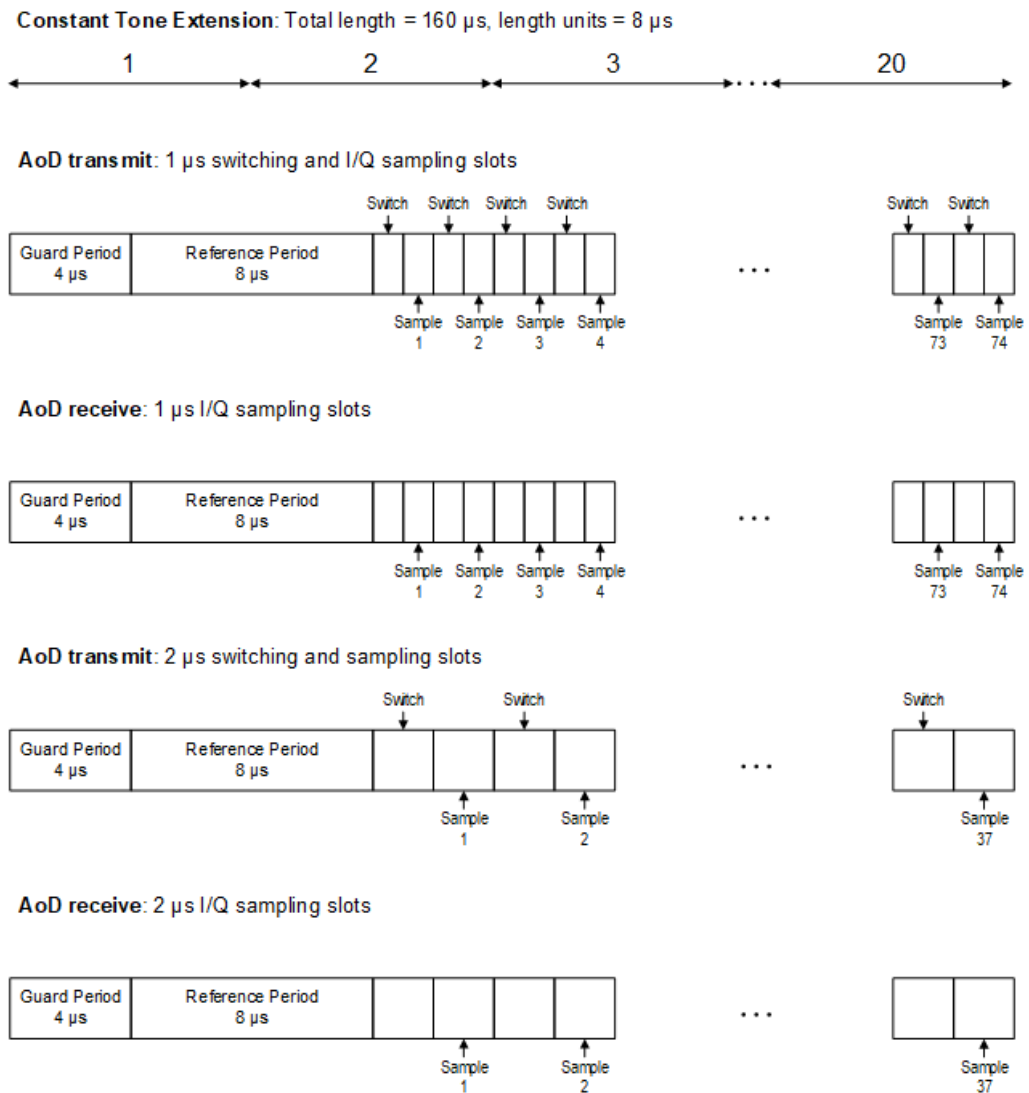

Figure 3-12: CTE structure for AoD method

For more information, refer to section 2.5 Constant Tone Extension and IQ Sampling of core specification for Bluetooth wireless technology, volume 6, part B.

### 3.2 About the Bluetooth BR/EDR/LE Modulation Characteristics measurement

To determine the modulation characteristics of the Bluetooth input signal, the R&S FSV3 Bluetooth measurement application performs an I/Q measurement. The measurement determines the maximum frequency deviation of all 8 bit sequences of the payload. In addition, the average value of the maximum frequency deviation for each packet is calculated. For a measurement according to the Bluetooth test specification,

the DUT is configured to transmit packets with the bit patterns "11110000" and "10101010" alternately. The sequence has to be repeated 10 times.

### Synchronization

The R&S FSV3 Bluetooth measurement application detects the bit pattern of the payload and attempts to synchronize the signal using the 64-bit sync word. The lower address part of the Bluetooth device address (LAP, the 24 least significant bits) determines the sync word used for sync search.

In a first step, the application automatically searches a burst within the RF signal. In a triggered measurement, the external trigger or the IF power trigger is used to determine the burst position.

In a second step, the application searches for the sync word position by correlating the signal with the sync word defined in the initialization phase. The application correlates the FM signal directly, not the data bits, which are only available after the phase shifter has been processed. The burst search process continues until the sync word is found.

After determining the position of the sync word, the application calculates the position of the first preamble bit (p0). The position is determined from the average value of all zero-crossing points, as defined in the RF test specification. Finally, the samples are shifted such that each sample matches one zero-crossing point (phase shifting).

### Output power

The only results that can be determined without synchronization are the output power results. The specified measurement time is 20% to 80% of the burst length. Without synchronization, the burst length is defined via the -3-dB points of the power trace. With synchronization, the burst starts with the p0 bit. Therefore, the measurement results can vary if the power of the DUT is not constant within the burst.

For EDR signals, the relative transmit power is measured. It is calculated as the ratio of the average transmission power of the GFSK and DPSK-modulated parts of the signal. (GFSK stands for Gaussian Frequency Shift Keying, while DPSK stands for Differential Phase Shift Keying.)

### Carrier frequency stability

For EDR signals, the carrier frequency stability is also measured during the modulation characteristics measurement. It verifies that the modulation accuracy and the frequency stability are within the required limits. The RF Test Specification requires evaluating 200 blocks, with a length of 50 µs each. Set the [Sweep Count](#), which corresponds to the number of packets, to a sufficient value to make sure the required 200 blocks are obtained. The following equation must be fulfilled:

$$No\_Blocks = floor \left( \frac{(56 + 8 * No\_Bytes)}{(2 * 50)} \right)$$

**Equation 3-1: Number of required blocks for 2DHx packets**

Where:

- floor = rounded to lower integer value
- Number of sweeps, depending on the number of payload bytes:

Bytes	Sweeps
31	67
58	40
356	7
358	7
656	4

$$No\_Blocks = \text{floor} \left( \frac{(68 + 8 * No\_Bytes)}{(3 * 50)} \right)$$

**Equation 3-2: Number of required blocks for 3DHx packets**

Where:

- floor = rounded to lower integer value
- Number of sweeps, depending on the number of payload bytes:

Bytes	Sweeps
11	200
86	40
536	7
986	4

### Initial carrier frequency tolerance (ICFT)

The initial carrier frequency tolerance determines the carrier offset of the four preamble bits. According to the RF Test Specification, the carrier offset is measured from the middle of the first preamble bit to the middle of the bit following the preamble.

### 3.2.1 Measurement filter

The RF specification allows high distortion power in the first adjacent channels. The 3-MHz filter does not suppress this kind of distortion, which leads to high interference in modulation. Therefore, precise measurement of the frequency deviation is not possible.

To obtain correct deviation results, the analyzer supplies an optional filter whose pass-band is only appropriate for the channel to measure. The Bluetooth spectrum has a bandwidth of 1 MHz. The filter is flat within 1.04 MHz (ripple: only 0.02 dB) and has steep edges. This measurement filter does not depend on the selected points per symbol value. As a result, the displayed deviation value increases by 3.2%. However, without the filter, the displayed deviation value can increase dramatically due to interference from adjacent channels. Generally, the result is more precise if the displayed deviation is lower with filtering than the deviation without filtering. In these cases, the inaccuracy caused by the adjacent channel interference is higher than the systematic inaccuracy caused by the filter.

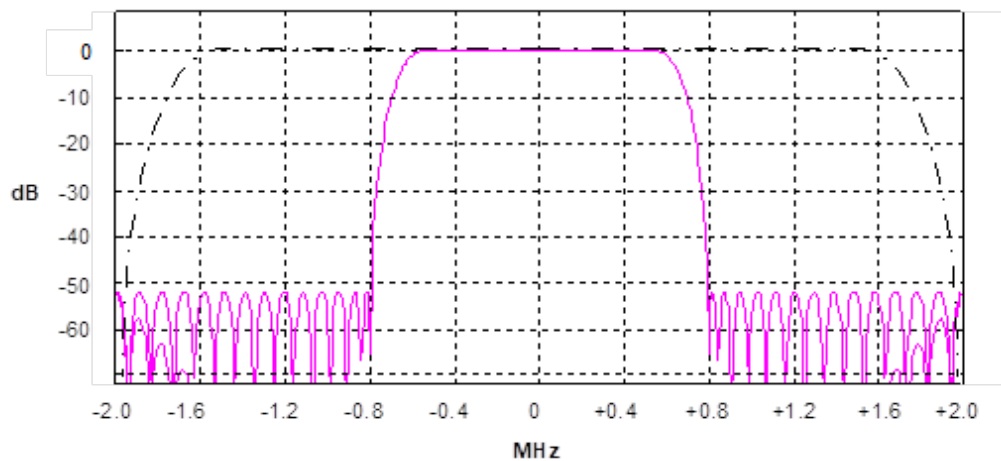

**Figure 3-13: Selection of digital filters**

Dashed trace = Standard filter with 4 points per symbol

Solid trace = Optional measurement filter, independent of the points per symbol setting

### 3.2.2 Trigger concepts

As the DUT (Device Under Test) uses frequency hopping, a trigger method is necessary for two reasons:

- A measurement is only possible during the period of time when a TX signal (burst) is available at the frequency under request.
- To determine the modulation characteristics correctly, the signal must be synchronized with the preamble.

To ensure stable synchronization, the DUT must be operated in reduced hopping mode. The DUT is only allowed to toggle between two frequencies, because otherwise the repetition time for the same frequency becomes higher than the record length.

If the test environment supplies an external trigger which marks the channel to be measured, synchronization is also possible with normal hopping operation.

## 3.3 About the Bluetooth BR/EDR/LE spurious emissions measurement

To measure the channel power in the individual channels of a Bluetooth signal, the specification defines the following procedure:

1. Determine the start and stop frequencies of the measurement:  
 $\langle \text{Start frequency} \rangle = \langle \text{Center frequency} \rangle - (k/2) \cdot \langle \text{Channel spacing} \rangle$   
 $\langle \text{Stop frequency} \rangle = \langle \text{Center frequency} \rangle + (k/2) \cdot \langle \text{Channel spacing} \rangle$

Where:

$\langle \text{Channel spacing} \rangle = 1 \text{ MHz or } 2 \text{ MHz}$ , depending on the operating mode

## About the Bluetooth BR/EDR/LE spurious emissions measurement

$k$  = number of channels = 79 or 40, depending on the operating mode

2. At the start frequency, perform 10 zero span sweeps with an RBW of 100 kHz and a sweep time of 100 ms.
3. Determine the average of the maximum power levels for each sweep.
4. Move the LO to 100 kHz.
5. Repeat [step 2](#) and [step 3](#) 10 times, that is: for a bandwidth of 1 MHz (= 1 channel).
6. Add up the average maximum power values for all subspans to determine the channel power level.

The R&S FSV3 Bluetooth measurement application performs a compliant measurement that is optimized for speed and performance.



## 4 Measurements and result displays

The R&S FSV3 Bluetooth measurement application provides two different measurements to determine the parameters described by the Bluetooth specifications.

The default **"Modulation Characteristics"** measurement determines basic signal parameters concerning packets, output power and bit patterns, for example.

The **"ACP / In-band Spurious Emissions"** measurement provides information on individual channels in the time and frequency domain.

### Selecting the measurement type

- ▶ To select a different measurement type, select one of the following:
  - "Overview" > "Select Measurement"
  - [MEAS] > "Select Measurement"

### Remote command:

[CONFigure:BT0oth:MEASurement](#) on page 117

### Selecting result displays

The data that was measured by the R&S FSV3 Bluetooth measurement application can be evaluated in various different modes. All evaluation modes available for the Bluetooth BR/EDR/LE measurements are displayed in the selection bar in SmartGrid mode.

To activate SmartGrid mode, do one of the following:

- 
  - Select "SmartGrid" from the toolbar.
- Select "Display" in the configuration "Overview".
- Select "Display Config" from [MEAS CONFIG].



For details on working with the SmartGrid, see the R&S FSV/A Getting Started manual.

Depending on the selected measurement, different result displays are available in the R&S FSV3 Bluetooth measurement application.

- [Result displays for Modulation Characteristics measurements](#).....34
- [Result displays for In-band Spurious Emissions measurements](#)..... 40

## 4.1 Result displays for Modulation Characteristics measurements

RF Envelope.....	34
RF Spectrum.....	34
Result Summary.....	35
Header Info.....	38
Marker Table.....	38
Demod waveform (not for EDR).....	39
Constellation (EDR only).....	39
Symbols (EDR only).....	40

### RF Envelope

Displays the power of the RF signal over time for all channels.

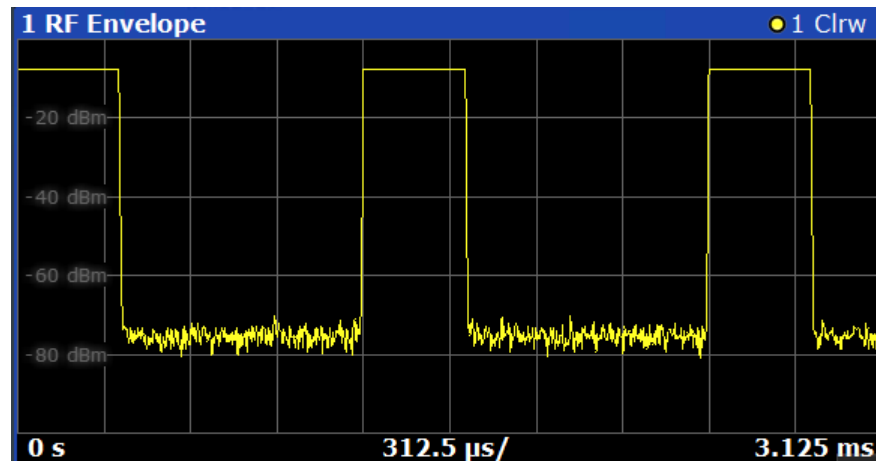

Remote command:

LAY:ADD? '1', RIGH, RFEN, see LAYout:ADD[:WINDow]? on page 188

Retrieving results:

TRACe<n>[:DATA]? on page 197

### RF Spectrum

Displays the power of the RF signal over frequency for a span of 4 MHz, i.e. 4 channels.

## Result displays for Modulation Characteristics measurements

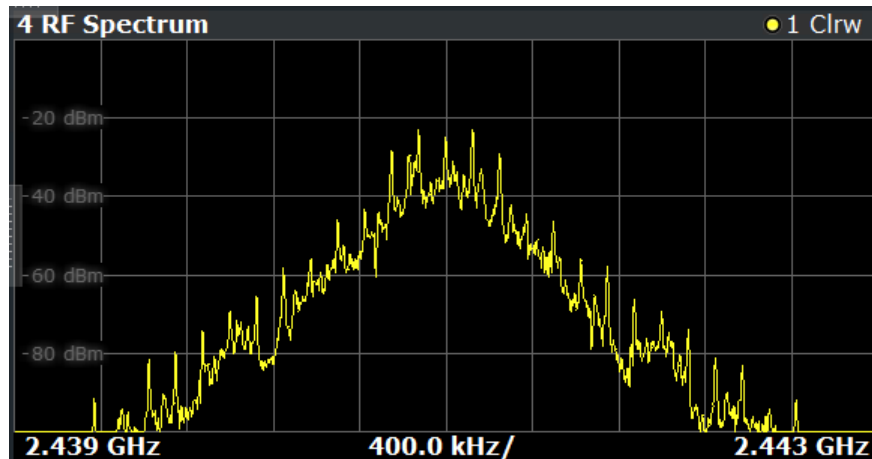

Remote command:

LAY:ADD? '1', RIGH, RFSP, see [LAYout:ADD\[:WINDow\]?](#) on page 188

Retrieving results:

TRACe<n>[:DATA] ? on page 197

### Result Summary

Displays packet information and the determined numerical modulation characteristics.

4 Result Summary					
Packet Information					
Packet Count	9		Packet Type		DH1
CRC/HEC Check Passed	9		Packet Length		366 sym
Modulation Characteristics	Current	Max	Min	Average	Limits
Output Power Peak	-7.73 dBm	-7.73 dBm	-7.73 dBm	-7.73 dBm	<= 23.00 dBm
Output Power Avg	*-7.80 dBm	*-7.80 dBm	*-7.80 dBm	*-7.80 dBm	(0.00 dBm, 20.00 dBm)
Output Power Rel	0.06 dB	0.06 dB	0.06 dB	0.06 dB	
Δ f1 (00001111) Max	160.99 kHz	160.99 kHz	160.99 kHz	160.99 kHz	
Δ f1 (00001111) Min	158.37 kHz	158.37 kHz	158.37 kHz	158.37 kHz	
Δ f1 (00001111) Avg	159.78 kHz	159.78 kHz	159.78 kHz	159.78 kHz	(140.00 kHz, 175.00 kHz)
Δ f2 (01010101) Max	---	---	---	---	115.00 kHz
Δ f2 (01010101) Min	---	---	---	---	
Δ f2 (01010101) Avg	---	---	---	---	
Δ f2 (max) in range	---	---	---	---	99.90 %
Δ f2 / Δ f1	---	---	---	---	0.80
Freq Drift	---	---	---	---	(-25.00 kHz, 25.00 kHz)
Max Drift Rate / 50μs	---	---	---	---	(-20.00 kHz, 20.00 kHz)
ICFT	34.79 Hz	34.79 Hz	34.79 Hz	34.79 Hz	(-75.00 kHz, 75.00 kHz)

For the modulation characteristics, the following results are provided:

- Current value
- Maximum value
- Minimum value
- Average value
- Specified limits

Values that exceed the specified limits are highlighted red.

**Table 4-1: Results for basic rate signals**

Result	Description
<b>Packet information</b>	
"Packet Count"	Number of measured packets

## Result displays for Modulation Characteristics measurements

Result	Description
"CRC/HEC Check Passed"	Number of packets that successfully passed the error correction check
"Packet Type"	See <a href="#">Chapter 3.1.1, "Bluetooth packet types for BR/EDR"</a> , on page 13 and <a href="#">Chapter 3.1.6, "Packet types for LE"</a> , on page 20
"Packet Length"	Number of symbols per packet
<b>Modulation characteristics</b>	
"Output Power Peak"	Maximum output power
"Output Power Avg"	Average output power
"Output Power Rel"	Relative output power (Relation maximum to average)
" $\Delta f_1$ (00001111) Max/Min/Avg"	Frequency offset for first test sequence
" $\Delta f_2$ (01010101) Max/Min/Avg"	Frequency offset for second test sequence
" $\Delta f_2$ (max) in range"	Percentage of the maximum frequency offset measurements that remained within the valid range (did not exceed the limits)
" $\Delta f_2 / \Delta f_1$ "	Relation between the frequency offsets of the first and second test sequence
"Freq Drift"	Difference between the average frequency of the 4 preamble bits and the average frequency of any 10-bit group of the payload.
"Max Drift Rate / 50 $\mu$ s"	Maximum frequency drift per packet
"ICFT / 50 $\mu$ s"	Maximum drift of the initial carrier frequency in BR signals for any 50- $\mu$ s time period within the payload field of the returned packets.

Table 4-2: Results for enhanced data rate signals

Result	Description
<b>Packet information</b>	
"Packet Count"	Number of measured packets
"Packet Type"	See <a href="#">Chapter 3.1.1, "Bluetooth packet types for BR/EDR"</a> , on page 13
"Packet Length"	Number of symbols within the packet
"CRC/HEC Check Passed"	Number of packets that successfully passed the error correction check
"Packet Passed PN9"	Packet has passed the limit check: 1: true, 0: false
"BER"	Bit error rate
<b>Modulation characteristics</b>	
"GFSK Avg Power"	Average power for GFSK-modulated part of the signal

## Result displays for Modulation Characteristics measurements

Result	Description
"DPSK Avg Power"	Average power for DPSK-modulated part of the signal
"Rel Avg Power"	Ratio of "GFSK Avg Power" to "DPSK Avg Power"
"RMS/Peak/99% DEVM QPSK"	RMS value, peak value and 99-percentile of the differential error vector magnitude for QPSK-modulated part of the signal
"RMS/Peak/99% DEVM 8PSK"	RMS value, peak value and 99-percentile of the differential error vector magnitude for 8PSK-modulated part of the signal
"Initial Frequency Offset"	Offset of the packet before any packet information is sent.
"Block Frequency Offset"	Offset of a block of 50 symbols
"Total Frequency Offset"	Total offset of signal

Table 4-3: Results for low energy signals

Result	Description
<b>Packet information</b>	
"Packet Count"	Number of measured packets
"Packet Type"	See <a href="#">Chapter 3.1.1, "Bluetooth packet types for BR/EDR"</a> , on page 13 and <a href="#">Chapter 3.1.6, "Packet types for LE"</a> , on page 20
"Packet Length"	Number of symbols per packet
<b>Modulation characteristics</b>	
"Output Power Peak"	Maximum output power
"Output Power Avg"	Average output power
"Output Power Rel"	Relative output power (Relation maximum to average)
" $\Delta f_1$ (00001111) Max/Min/Avg"	Frequency offset for first test sequence
" $\Delta f_2$ (01010101) Max/Min/Avg"	Frequency offset for second test sequence
" $\Delta f_2$ (max) in range" " $\Delta f_1$ (max) in range" (LE coded)	Percentage of the maximum frequency offset measurements that remained within the valid range (did not exceed the limits)
" $\Delta f_2 / \Delta f_1$ "	Relation between the frequency offsets of the first and second test sequence
"Freq Drift"	Difference between the average frequency of the 4 preamble bits and the average frequency of any 10-bit group of the payload.
"Max Drift Rate / 50 $\mu$ s" "Max Drift Rate / 48 $\mu$ s" (LE coded)	Maximum frequency drift per packet

## Result displays for Modulation Characteristics measurements

Result	Description
"Freq Offset"	Frequency offset without preamble and payload detection
"Initial Freq Drift"	Drift of the initial carrier frequency

Remote command:

LAY:ADD? '1', RIGH, RSUM, see [LAYout:ADD\[:WINDow\]?](#) on page 188

Retrieving results:

TRACe<n>[:DATA]? on page 197

### Header Info

Provides information from the decoded payload header of the captured packet.

Which information is provided depends on the standard and packet type.

For BR/EDR signals, packet header and PDU header information is available. For LE signals, only PDU header information is available.

For details, see the Bluetooth specification documents.

5 Header Info			
Packet Header			
LT Address	0	Type	DH1
Flow	GO	ARQN	ACK
SEQN	1	HEC	0xA5
PDU Header			
LLID	2	Flow	GO
Length	27	---	---

Figure 4-1: Header information for a Bluetooth BR signal

1 Header Info			
Packet Header			
PayLoad Type	PRBS-9	RFU1	0
CP	0	RFU2	0
Length	37	---	---

Figure 4-2: Header information for a Bluetooth LE 1M signal

Remote command:

LAY:ADD? '1', RIGH, HDR, see [LAYout:ADD\[:WINDow\]?](#) on page 188

Retrieving results:

TRACe<n>[:DATA]? on page 197

### Marker Table

Displays a table with the current marker values for the active markers.

This table is displayed automatically if configured accordingly.

Wnd	Type	Ref	Trc	X-value	Y-value
1	M1		1	2.409 55 GHz	-74.566 dBm
1	D2	M1	1	0.0 Hz	0.0 dBm
1	D3	M1	1	0.0 Hz	0.0 dBm

## Result displays for Modulation Characteristics measurements

**Tip:** To navigate within long marker tables, simply scroll through the entries with your finger on the touchscreen.

Remote command:

LAY:ADD? '1',RIGH,MTAB, see [LAYout:ADD\[:WINDow\]?](#) on page 188

Results:

[CALCulate<n>:MARKer<m>:X](#) on page 178

### Demod waveform (not for EDR)

Displays the demodulated signal frequency versus (measurement) time.

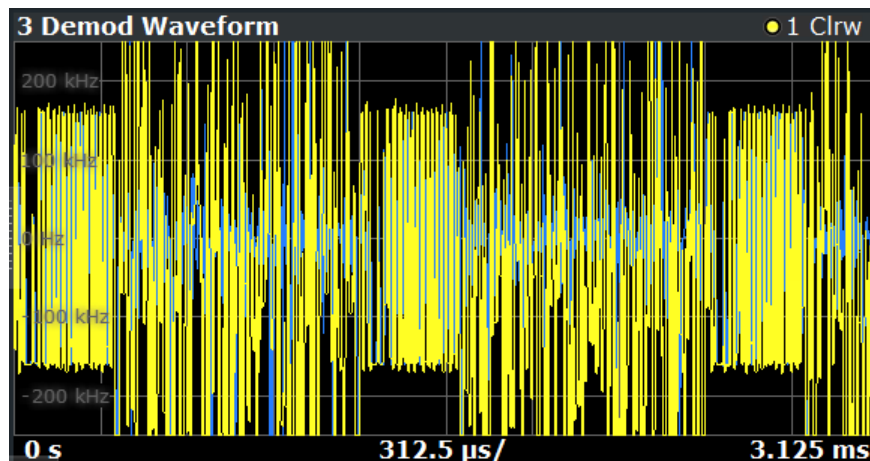

Remote command:

LAY:ADD? '1',RIGH,DWAV, see [LAYout:ADD\[:WINDow\]?](#) on page 188

Retrieving results:

[TRACe<n>\[:DATA\]?](#) on page 197

### Constellation (EDR only)

Displays the captured samples in an I/Q plot.

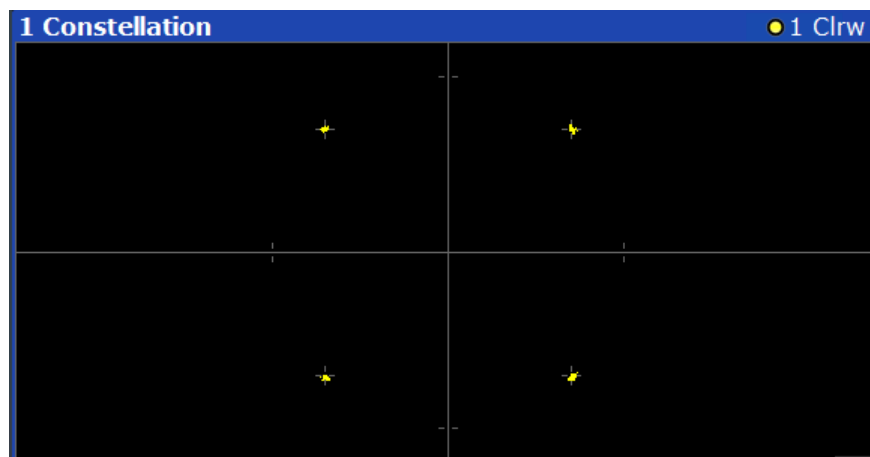

Remote command:

LAY:ADD? '1',RIGH,CONS, see [LAYout:ADD\[:WINDow\]?](#) on page 188

Retrieving results:

[TRACe<n>\[:DATA\]?](#) on page 197

Result displays for In-band Spurious Emissions measurements

**Symbols (EDR only)**

Displays the demodulated symbols for all channels.

2 Symbols															
	0	1	2	3	4	5	6	7	8	9	10	11	12	13	14
0	1	0	1	0	1	1	1	0	1	0	1	1	1	1	0
15	0	1	1	0	0	1	1	0	0	1	1	1	1	0	1
30	0	0	0	0	1	0	1	1	1	0	0	0	0	0	0
45	0	0	0	0	0	0	0	0	0	0	0	0	0	0	0
60	0	0	0	0	1	1	1	0	1	0	1	0	1	0	0
75	0	0	0	0	0	0	0	0	0	0	0	0	1	1	1
90	0	0	0	1	1	1	1	1	1	1	1	1	1	1	1
105	0	0	0	1	1	1	0	0	0	0	0	0	1	1	1
120	0	0	0	1	1	1	-	-	-	-	-	01	11	01	11
135	01	11	11	01	01	01	01	10	11	01	10	00	00	00	11
150	11	11	11	10	00	00	11	11	01	11	11	00	01	01	11
165	00	11	00	10	00	00	10	01	01	00	11	10	11	01	00
180	01	11	10	01	11	11	00	11	01	10	00	10	10	10	01
195	00	01	11	00	01	10	11	01	01	01	11	00	01	00	11
210	00	01	00	01	00	00	00	00	10	00	01	00	01	10	00
225	01	00	11	10	01	01	01	01	10	00	01	10	11	11	01
240	00	11	01	11	00	10	00	10	10	00	01	01	01	10	10

Format: 2-DH1    72 x Access Code    54 x Header    5 x Guard(symbolic)    10 x Sync    234 x Payload

**Note:** For payload symbols, QPSK-modulated symbols are represented by 2 bits, while 8PSK-modulated symbols are represented by 3 bits.

The packet format and the number of symbols for the different packet contents are indicated beneath the table. The symbols for each type of packet content are indicated in a different color.

Remote command:

LAY:ADD? '1', RIGH, SYMB, see LAYout:ADD[:WINDow]? on page 188

Retrieving results:

TRACe<n>[:DATA]? on page 197

## 4.2 Result displays for In-band Spurious Emissions measurements

ACP / In-band Spurious Emissions.....	40
Result Summary.....	41
Marker Table.....	42

### ACP / In-band Spurious Emissions

Displays the power of the RF signal over frequency for all channels. In addition, the limit line is displayed, defined by concatenating the specified limits for the different channels. For details, see Chapter 6.2.4, "Checking limits", on page 88.

The results of the ACP and general limit check are indicated.



## Result displays for In-band Spurious Emissions measurements

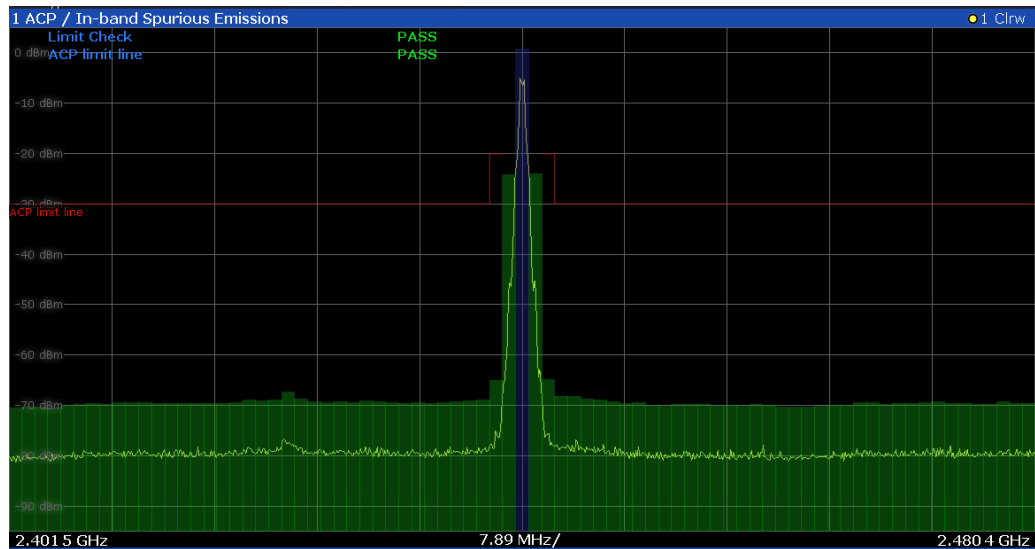

Any channels that exceed the limits are highlighted in red.

The currently selected transmit (TX) channel is highlighted blue in the table, see ["TX Channel"](#) on page 67. You can step through the individual channels using the [Channel No](#) function and the rotary knob or arrow keys.

Remote command:

LAY:ADD? '1',RIGH,SPEC, see [LAYout:ADD\[:WINDow\]?](#) on page 188

Retrieving results:

[TRACe<n>\[:DATA\]?](#) on page 197

[CALCulate<n>:LIMit:FAIL?](#) on page 195

### Result Summary

Indicates the numerical power measurement results per channel.

In addition, the most important results for the currently selected transmit and adjacent channels are indicated at the top of the table.

Channel power values that exceed the limit line are highlighted red.

2 Result Summary									
TX Channel: -70.53 dBm					No of Exceptions: 3				
Adj Channel Lower: N/A					Adj Channel Upper: -70.36 dBm				
Alt Channel Lower: N/A					Alt Channel Upper: -70.57 dBm				
Channel No	Frequency	Power	Limit	Delta Limit	Channel No	Frequency	Power	Limit	Delta Limit
0	2.411 0 GHz	-70.53 dBm	N/A	N/A	1	2.412 0 GHz	-70.36 dBm	N/A	N/A
2	2.413 0 GHz	-70.57 dBm	-20.00 dBm	50.57 dBc	3	2.414 0 GHz	-70.27 dBm	-40.00 dBm	30.27 dBc
4	2.415 0 GHz	-70.55 dBm	-40.00 dBm	30.55 dBc	5	2.416 0 GHz	-70.42 dBm	-40.00 dBm	30.42 dBc
6	2.417 0 GHz	-70.16 dBm	-40.00 dBm	30.16 dBc	7	2.418 0 GHz	-70.30 dBm	-40.00 dBm	30.30 dBc
8	2.419 0 GHz	-70.44 dBm	-40.00 dBm	30.44 dBc	9	2.420 0 GHz	-70.17 dBm	-40.00 dBm	30.17 dBc
10	2.421 0 GHz	-70.08 dBm	-40.00 dBm	30.08 dBc	11	2.422 0 GHz	-70.03 dBm	-40.00 dBm	30.03 dBc
12	2.423 0 GHz	-70.28 dBm	-40.00 dBm	30.28 dBc	13	2.424 0 GHz	-69.98 dBm	-40.00 dBm	29.98 dBc
14	2.425 0 GHz	-69.96 dBm	-40.00 dBm	29.96 dBc	15	2.426 0 GHz	-70.11 dBm	-40.00 dBm	30.11 dBc
16	2.427 0 GHz	-70.03 dBm	-40.00 dBm	30.03 dBc	17	2.428 0 GHz	-70.26 dBm	-40.00 dBm	30.26 dBc
18	2.429 0 GHz	-68.57 dBm	-40.00 dBm	28.57 dBc	19	2.430 0 GHz	-69.63 dBm	-40.00 dBm	29.63 dBc

Figure 4-3: Result summary for in-band spurious emissions measurement for basic rate signal

The currently selected transmit channel is highlighted blue in the table, see ["TX Channel"](#) on page 67. You can step through the individual channels using the [Channel No](#) function and the rotary knob or arrow keys.

## Result displays for In-band Spurious Emissions measurements

Result	Description
<b>ACP results</b>	
"TX channel"	Power of the currently selected TX channel, see <a href="#">"Channel No"</a> on page 67
"No. of Exceptions"	Number of channels that exceed the ACP limit line Value turns red if an adjacent or alternate1 channel exceeds the limit line, or if the acceptable number of exceptions is exceeded (see <a href="#">"Allowed Exceptions"</a> on page 89).
"Adj Channel Lower"	Power of the lower adjacent channel
"Adj Channel Upper"	Power of the upper adjacent channel
"Alt Channel Lower"	Power of the lower alternate channel
"Alt Channel Upper"	Power of the upper alternate channel
<b>EDR mode</b>	
"Guard position"	The start of the guard time before the payload in the packet. The measurement starts after the guard time.
"Meas Time"	The time the measurement is actually performed, starting with the guard time.
<b>Channel results</b>	
"Channel No."	Channel number - absolute or relative to TX, depending on <a href="#">"Channel Number Abs/Rel"</a> on page 90 For BT LE mode, the number also depends on the <a href="#">"Channel Format"</a> on page 67.
"Frequency"	Center frequency of the channel
"Power"	Channel power
"Limit"	Defined power limit for the channel (for active limit check only)
Limit check result	Red channel power value: FAIL Green channel power value: PASS White channel power value (Limit check: off): PASS
"Delta Limit"	Delta of the measured power value to the specified limit value

Remote command:

LAY:ADD? '1', RIGH, RSUM, see [LAYout:ADD\[:WINDow\]?](#) on page 188

Retrieving results:

[TRACe<n>\[:DATA\]?](#) on page 197

[CALCulate<n>:LIMit:FAIL?](#) on page 195

### Marker Table

Displays a table with the current marker values for the active markers.

This table is displayed automatically if configured accordingly.

## Result displays for In-band Spurious Emissions measurements

Wnd	Type	Ref	Trc	X-value	Y-value
1	M1		1	<b>2.409 55 GHz</b>	<b>-74.566 dBm</b>
1	D2	M1	1	<b>0.0 Hz</b>	<b>0.0 dBm</b>
1	D3	M1	1	<b>0.0 Hz</b>	<b>0.0 dBm</b>

**Tip:** To navigate within long marker tables, simply scroll through the entries with your finger on the touchscreen.

Remote command:

LAY:ADD? '1',RIGH, MTAB, see LAYout:ADD[:WINDow]? on page 188

Results:

CALCulate<n>:MARKer<m>:X on page 178

## 5 Configuration

**Access:** [MODE] > "Bluetooth"

Bluetooth BR/EDR/LE measurements require a special application on the R&S FSV/A.

When you activate an R&S FSV3 Bluetooth measurement application the first time, a set of parameters is passed on from the currently active application. After initial setup, the parameters for the channel are stored upon exiting and restored upon re-entering the channel. Thus, you can switch between applications quickly and easily.

When you activate a measurement channel in the R&S FSV3 Bluetooth measurement application, a Bluetooth BR/EDR/LE measurement for the input signal is started automatically with the default configuration. The Bluetooth "Modulation Characteristics" menu is displayed and provides access to the most important configuration functions.

The remote commands required to perform these tasks are described in [Chapter 9, "Remote commands to perform Bluetooth BR/EDR/LE measurements"](#), on page 106.

- [Configuration overview](#).....44
- [Configuration according to digital standards](#).....46
- [Input, output and frontend settings](#).....47
- [Trigger settings](#).....58
- [Gate settings](#).....61
- [Modulation Characteristics measurement settings](#).....63
- [In-band Spurious Emissions measurement settings](#).....66
- [Sweep settings](#).....68
- [Adjusting settings automatically](#).....70

### 5.1 Configuration overview



**Access:** "Meas Config" > "Overview"

Throughout the measurement channel configuration, an overview of the most important currently defined settings is provided in the "Overview".

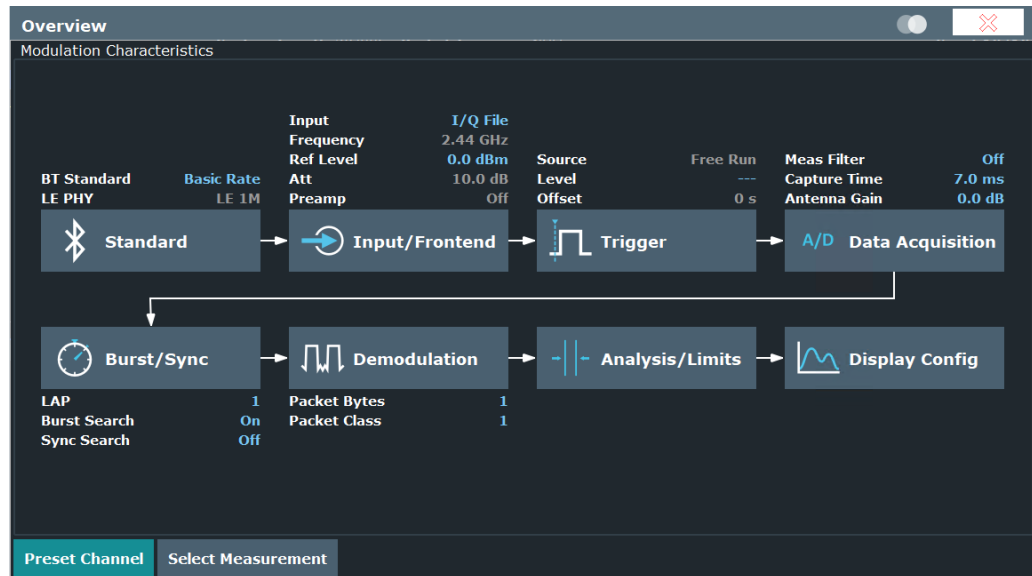

Figure 5-1: Configuration overview for modulation accuracy measurement

In addition to the main measurement settings, the "Overview" provides quick access to the main settings dialog boxes. The individual configuration steps are displayed in the order of the data flow. Thus, you can easily configure an entire measurement channel from input over processing to output and analysis by stepping through the dialog boxes as indicated in the "Overview".

In particular, the "Overview" provides quick access to the following configuration dialog boxes (listed in the recommended order of processing):

1. "Standard"  
See [Chapter 5.2, "Configuration according to digital standards"](#), on page 46
2. "Input/Frontend"  
See [Chapter 5.3, "Input, output and frontend settings"](#), on page 47
3. "Trigger"  
See [Chapter 5.4, "Trigger settings"](#), on page 58
4. "Data Acquisition"  
See [Chapter 5.6.1, "Data acquisition"](#), on page 63
5. "Burst/Sync"  
See [Chapter 5.6.2, "Burst and synchronization settings"](#), on page 64
6. "Demodulation"  
See [Chapter 5.6.3, "Demodulation settings"](#), on page 66
7. "Analysis/Limits"  
For modulation accuracy: See [Chapter 6.1, "Analyzing modulation characteristics"](#), on page 72 and [Chapter 6.1.1.2, "Checking limits \(BR\)"](#), on page 74  
For in-band spurious emissions: See [Chapter 6.2, "Analyzing in-band spurious emissions"](#), on page 83 and [Chapter 6.2.4, "Checking limits"](#), on page 88

8. "Display Config"  
See [Chapter 6.5, "Display configuration"](#), on page 98

#### To configure settings

- ▶ Select any button in the "Overview" to open the corresponding dialog box.  
Select a setting in the channel bar (at the top of the measurement channel tab) to change a specific setting.

For step-by-step instructions on configuring Bluetooth BR/EDR/LE measurements, see [Chapter 7, "How to perform Bluetooth BR/EDR/LE measurements"](#), on page 99.

#### Preset Channel

Select "Preset Channel" in the lower left-hand corner of the "Overview" to restore all measurement settings *in the current channel* to their default values.

**Note:** Do not confuse "Preset Channel" with the [Preset] key, which restores the entire instrument to its default values and thus closes *all channels* on the R&S FSV/A (except for the default channel)!

Remote command:

`SYSTem:PRESet:CHANnel[:EXEC]` on page 116

#### Select Measurement

Selects a measurement to be performed.

See [Chapter 4, "Measurements and result displays"](#), on page 33.

Remote command:

`CONFigure:BT0oth:MEASurement` on page 117

#### Specific Settings for

The channel can contain several windows for different results. Thus, the settings indicated in the "Overview" and configured in the dialog boxes vary depending on the selected window.

Select an active window from the "Specific Settings for" selection list that is displayed in the "Overview" and in all window-specific configuration dialog boxes.

The "Overview" and dialog boxes are updated to indicate the settings for the selected window.

## 5.2 Configuration according to digital standards

**Access:** "Overview" > "Standard"

**Or:** "Meas Config" > "Standard"

Different Bluetooth standards allow for different modulation modes and energy levels. To configure the R&S FSV3 Bluetooth measurement application, you must define which standard the input signal complies with.

The measurements are configured according to the specified standard, e.g. regarding demodulation or the power range.

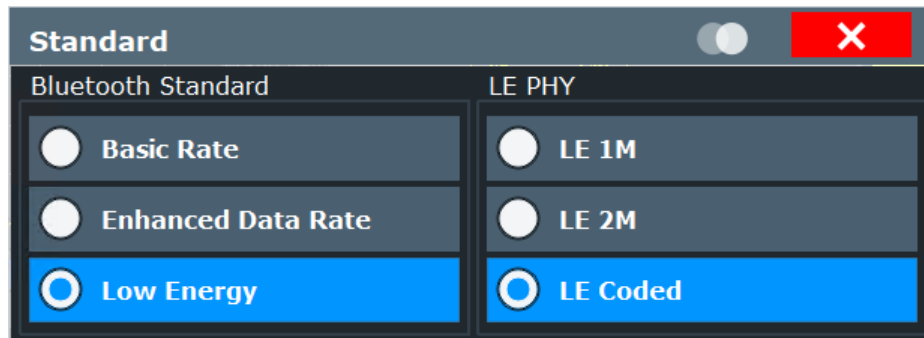

Predefined settings for frequency, channels and trigger settings are also available for in-band spurious emissions analysis, see [Chapter 6.2.3, "Saving and loading predefined settings"](#), on page 87.

[Standard](#).....47

### Standard

Defines the Bluetooth standard that the signal complies with. The measurements are configured according to the specified standard with the correct frequency range and number of channels.

For details on the different standards, see [Chapter 3, "Measurement basics"](#), on page 12.

For measurements based on the **low-energy** standard, different substandards are available depending on the used transmission mode (PHY). For details, see [Chapter 3.1, "About Bluetooth BR/EDR/LE"](#), on page 12.

- **LE 1M**: uncoded, 1 symbol per data bit, 1 Msymbol/s data rate
- **LE 2M**: uncoded, 1 symbol per data bit, 2 Msymbol/s data rate
- **LE Coded**: 2 symbols per data bit, 1 Msymbol/s data rate

Remote command:

`CONFigure:BT0oth[:STANdard]` on page 116

`CONFigure:BT0oth:LEnergy` on page 117

## 5.3 Input, output and frontend settings

**Access:** "Overview" > "Input/Frontend" > "Input"

or: [INPUT/OUTPUT]

Some settings are also available in the "Amplitude" tab of the "Amplitude" dialog box.

- [Radio frequency input](#)..... 48
- [Settings for input from I/Q data files](#)..... 50
- [Output settings](#)..... 51
- [Frequency settings](#)..... 52
- [Amplitude settings](#)..... 54

### 5.3.1 Radio frequency input

**Access:** "Overview" > "Input/Frontend" > "Input" > "Radio Frequency"

or: [INPUT/OUTPUT] > "Input Source Config" > "Input Source" > "Radio Frequency"

The default input source for the R&S FSV/A is the radio frequency.

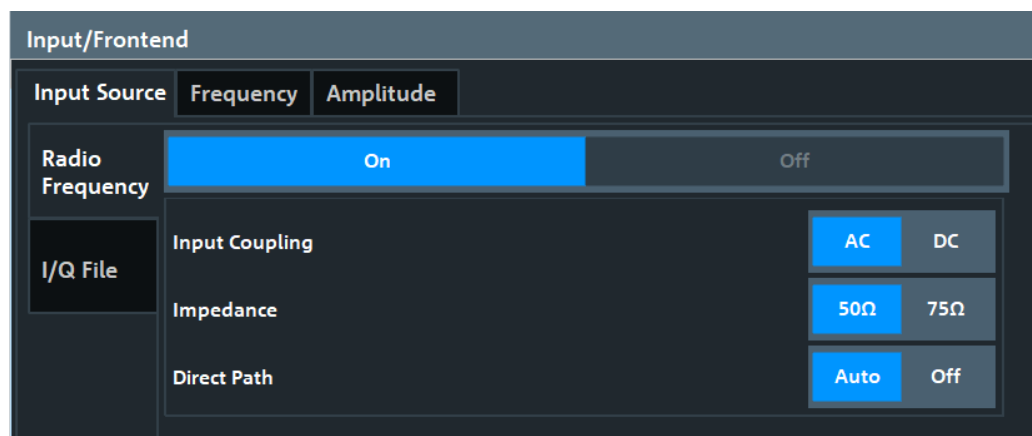

#### RF Input Protection

The RF input connector of the R&S FSV/A must be protected against signal levels that exceed the ranges specified in the specifications document. Therefore, the R&S FSV/A is equipped with an overload protection mechanism for DC and signal frequencies up to 30 MHz. This mechanism becomes active as soon as the power at the input mixer exceeds the specified limit. It ensures that the connection between RF input and input mixer is cut off.

When the overload protection is activated, an error message is displayed in the status bar ("INPUT OVLD"), and a message box informs you that the RF input was disconnected. Furthermore, a status bit (bit 3) in the `STAT:QUES:POW` status register is set. In this case, you must decrease the level at the RF input connector and then close the message box. Then measurement is possible again. Reactivating the RF input is also possible via the remote command `INPut:ATTenuation:PROTection:RESet`.

- [Radio Frequency State](#)..... 49
- [Input Coupling](#)..... 49
- [Direct Path](#)..... 49
- [YIG-Preselector](#)..... 49
- [Impedance](#)..... 50



### Radio Frequency State

Activates input from the "RF Input" connector.

Remote command:

[INPut:SElect](#) on page 120

### Input Coupling

The RF input of the R&S FSV/A can be coupled by alternating current (AC) or direct current (DC).

AC coupling blocks any DC voltage from the input signal. AC coupling is activated by default to prevent damage to the instrument. Very low frequencies in the input signal can be distorted.

However, some specifications require DC coupling. In this case, you must protect the instrument from damaging DC input voltages manually. For details, refer to the specifications document.

Remote command:

[INPut:COUpling](#) on page 118

### Direct Path

Enables or disables the use of the direct path for small frequencies.

In spectrum analyzers, passive analog mixers are used for the first conversion of the input signal. In such mixers, the LO signal is coupled into the IF path due to its limited isolation. The coupled LO signal becomes visible at the RF frequency 0 Hz. This effect is referred to as LO feedthrough.

To avoid the LO feedthrough the spectrum analyzer provides an alternative signal path to the A/D converter, referred to as the *direct path*. By default, the direct path is selected automatically for RF frequencies close to zero. However, this behavior can be disabled. If "Direct Path" is set to "Off", the spectrum analyzer always uses the analog mixer path.

"Auto" (Default) The direct path is used automatically for frequencies close to zero.

"Off" The analog mixer path is always used.

Remote command:

[INPut:DPATH](#) on page 119

### YIG-Preselector

Enables or disables the YIG-preselector.

This setting requires an additional option on the R&S FSV/A.

**Note:** Note that the YIG-preselector is active only on frequencies greater than 7.5 GHz. Therefore, switching the YIG-preselector on or off has no effect if the frequency is below that value.

To use the optional 54 GHz frequency extension (R&S FSV3-B54G), the YIG-preselector must be disabled.

Remote command:

[INPut:FILTer:YIG\[:STATe\]](#) on page 119

**Impedance**

The R&S FSV/A has an internal impedance of 50  $\Omega$ . However, some applications use other impedance values. To match the impedance of an external application to the impedance of the R&S FSV/A, an *impedance matching pad* can be inserted at the input. If the type and impedance value of the used matching pad is known to the R&S FSV/A, it can convert the measured units accordingly so that the results are calculated correctly.

The impedance conversion does not affect the level of the output signals (such as IF, video, demod).

"50 $\Omega$ "	(Default:) no conversion takes place
"75 $\Omega$ "	The 50 $\Omega$ input impedance is transformed to a higher impedance using a 75 $\Omega$ adapter of the selected "Pad Type": "Series-R" (default) or "MLP" (Minimum Loss Pad)
"User"	The 50 $\Omega$ input impedance is transformed to a user-defined impedance value according to the selected "Pad Type": "Series-R" (default) or "MLP" (Minimum Loss Pad)

Remote command:

[INPut: IMPedance](#) on page 120

[INPut: IMPedance: PTYPe](#) on page 120

**5.3.2 Settings for input from I/Q data files**

**Access:** "Overview" > "Input/Frontend" > "Input Source" > "I/Q File"

**Or:** [INPUT/OUTPUT] > "Input Source Config" > "Input Source" > "I/Q File"

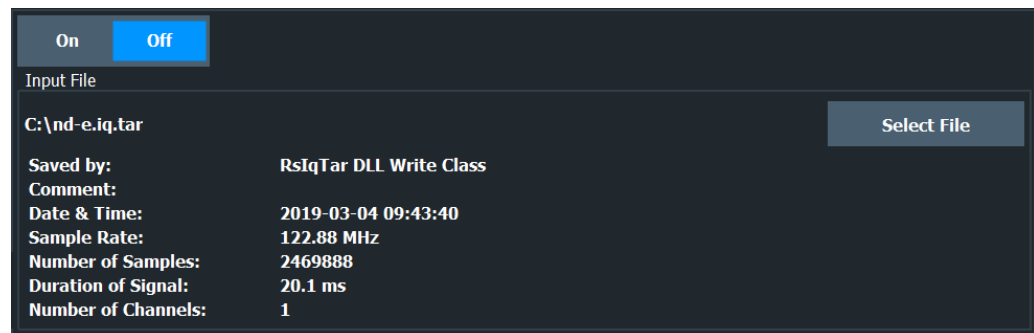

[I/Q Input File State](#)..... 50

[Select I/Q data file](#)..... 51

**I/Q Input File State**

Enables input from the selected I/Q input file.

If enabled, the application performs measurements on the data from this file. Thus, most measurement settings related to data acquisition (attenuation, center frequency, measurement bandwidth, sample rate) cannot be changed. The measurement time can only be decreased to perform measurements on an extract of the available data only.

**Note:** Even when the file input is disabled, the input file remains selected and can be enabled again quickly by changing the state.

Remote command:

[INPut:SElect](#) on page 120

#### Select I/Q data file

Opens a file selection dialog box to select an input file that contains I/Q data.

The I/Q data file must be in one of the following supported formats:

- .iq.tar
- .iqw
- .csv
- .mat
- .wv
- .aid

The file type is determined by the file extension. If no file extension is provided, the file type is assumed to be .iq.tar. For .mat files, Matlab® v4 is assumed.

**Note:** Only a single data stream or channel can be used as input, even if multiple streams or channels are stored in the file.

**Note:** For some file formats that do not provide the sample rate and measurement time or record length, you must define these parameters manually. Otherwise the traces are not visible in the result displays.

The default storage location for I/Q data files is C:\R\_S\INSTR\USER.

Remote command:

[INPut:FILE:PATH](#) on page 121

### 5.3.3 Output settings

**Access:** [Input/Output] > "Output"

The R&S FSV/A can provide output to special connectors for other devices.

For details on connectors, refer to the R&S FSV/A Getting Started manual, "Front / Rear Panel View" chapters.



How to provide trigger signals as output is described in detail in the R&S FSV/A User Manual.

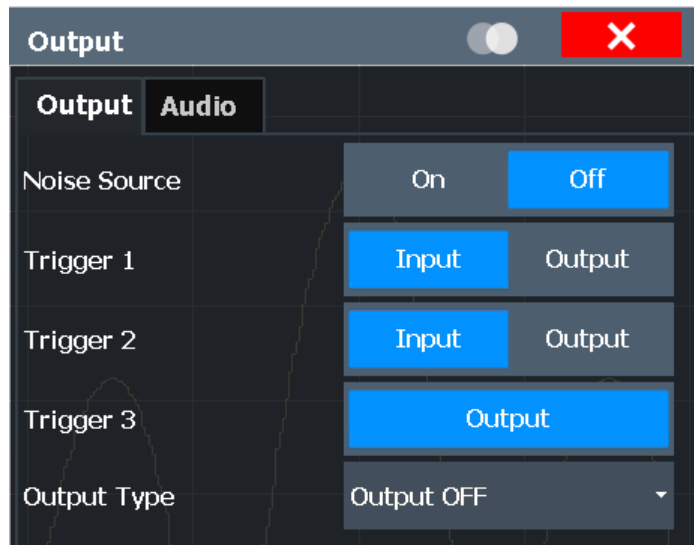

Noise Source Control..... 52

#### Noise Source Control

Enables or disables the 28 V voltage supply for an external noise source connected to the "Noise source control / Power sensor") connector. By switching the supply voltage for an external noise source on or off in the firmware, you can enable or disable the device as required.

External noise sources are useful when you are measuring power levels that fall below the noise floor of the R&S FSV/A itself, for example when measuring the noise level of an amplifier.

In this case, you can first connect an external noise source (whose noise power level is known in advance) to the R&S FSV/A and measure the total noise power. From this value, you can determine the noise power of the R&S FSV/A. Then when you measure the power level of the actual DUT, you can deduct the known noise level from the total power to obtain the power level of the DUT.

Remote command:

[DIAGnostic:SERvice:NSource](#) on page 122

### 5.3.4 Frequency settings

**Access:** "Overview" > "Frequency"

**Or:** [FREQ] > "Freq Config"

Input/Frontend	
Input Source	Frequency
Frequency	
Center	2.441 GHz
Center Frequency Stepsize	
Stepsize	Manual Value 1.0 MHz
Frequency Offset	
Value	0 Hz

Center Frequency.....	53
Frequency Stepsize.....	53
Frequency Offset.....	53

### Center Frequency

Indicates the center frequency (frequency domain) or measuring frequency (time domain).

The value depends on the used standard. See also [Chapter 6.2.1, "Measurement settings depending on standard"](#), on page 83.

Remote command:

[SENSe:] FREQuency:CENTer on page 169

### Frequency Stepsize

Indicates the step size by which the center frequency is increased or decreased when the arrow keys are pressed. When you use the rotary knob, the center frequency changes in much smaller steps (1/10 the size as for the arrow keys).

The value depends on the used standard. See also [Chapter 6.2.1, "Measurement settings depending on standard"](#), on page 83.

Remote command:

[SENSe:] FREQuency:CENTer:STEP on page 169

### Frequency Offset

Shifts the displayed frequency range along the x-axis by the defined offset.

This parameter has no effect on the instrument's hardware, on the captured data, or on data processing. It is simply a manipulation of the final results in which absolute frequency values are displayed. Thus, the x-axis of a spectrum display is shifted by a constant offset if it shows absolute frequencies. However, if it shows frequencies relative to the signal's center frequency, it is not shifted.

A frequency offset can be used to correct the display of a signal that is slightly distorted by the measurement setup, for example.

The allowed values range from -1 THz to 1 THz. The default setting is 0 Hz.

Remote command:

[SENSe:] FREQuency: OFFSet on page 132

### 5.3.5 Amplitude settings

**Access:** "Overview" > "Amplitude"

**Or:** [AMPT] > "Amplitude Config"

Amplitude settings affect the signal power or error levels.

Input/Frontend	
<b>Input Source</b>	<b>Amplitude</b>
Reference Level	
Value	0.0 dBm
Offset	0.0 dB
Input Settings	
Preamplifier	On <input type="checkbox"/> Off <input checked="" type="checkbox"/>
Input Coupling	AC <input checked="" type="checkbox"/> DC <input type="checkbox"/>
Impedance	50Ω <input checked="" type="checkbox"/> 75Ω <input type="checkbox"/>
Attenuation	
Mode	Auto <input checked="" type="checkbox"/> Manual <input type="checkbox"/>
Value	10.0 dB
Optimization	Low Distortion
Electronic Attenuation	
State	On <input type="checkbox"/> Off <input checked="" type="checkbox"/>
Mode	Auto <input type="checkbox"/> Manual <input type="checkbox"/>
Value	0 dB

Reference Level.....	54
L Shifting the Display (Offset).....	55
Input Settings.....	55
L Preamplifier.....	55
L Input Coupling.....	56
L Impedance.....	56
RF Attenuation.....	56
L Attenuation Mode / Value.....	56
L Optimization.....	57
Using Electronic Attenuation.....	57

#### Reference Level

Defines the expected maximum reference level. Signal levels above this value are possibly not measured correctly. Signals above the reference level are indicated by an "IF Overload" or "OVLd" status display.

The reference level can also be used to scale power diagrams; the reference level is then used for the calculation of the maximum on the y-axis.

Since the hardware of the R&S FSV/A is adapted according to this value, it is recommended that you set the reference level close above the expected maximum signal level. Thus you ensure an optimal measurement (no compression, good signal-to-noise ratio).

Remote command:

```
DISPlay[:WINDow<n>][:SUBWindow<w>]:TRACe<t>:Y[:SCALe]:RLEVel
```

on page 126

### Shifting the Display (Offset) ← Reference Level

Defines an arithmetic level offset. This offset is added to the measured level. In some result displays, the scaling of the y-axis is changed accordingly.

Define an offset if the signal is attenuated or amplified before it is fed into the R&S FSV/A so the application shows correct power results. All displayed power level results are shifted by this value.

The setting range is  $\pm 200$  dB in 0.01 dB steps.

Note, however, that the *internal* reference level (used to adjust the hardware settings to the expected signal) ignores any "Reference Level Offset". Thus, it is important to keep in mind the actual power level the R&S FSV/A must handle. Do not rely on the displayed reference level (internal reference level = displayed reference level - offset).

Remote command:

```
DISPlay[:WINDow<n>][:SUBWindow<w>]:TRACe<t>:Y[:SCALe]:RLEVel:
```

OFFSet on page 126

### Input Settings

Some input settings affect the measured amplitude of the signal, as well.

For information on other input settings, see [Chapter 5.3, "Input, output and frontend settings"](#), on page 47

### Preamplifier ← Input Settings

If the (optional) internal preamplifier hardware is installed on the R&S FSV/A, a preamplifier can be activated for the RF input signal.

For R&S FSV/A, the following settings are available:

"Off"	Deactivates the preamplifier.
"15 dB"	The RF input signal is amplified by about 15 dB.
"30 dB"	The RF input signal is amplified by about 30 dB.
"On"	Using the preamplifier with the option number 1330.3465.02: the input signal is amplified by 30 dB if the preamplifier is activated.

For R&S FSV/A3044 models, the preamplifier is only available under the following conditions:

- In zero span, the maximum center frequency is 43.5 GHz
- For frequency spans, the maximum stop frequency is 43.5 GHz
- For I/Q measurements, the maximum center frequency depends on the analysis bandwidth:

$$f_{center} \leq 43.5 \text{ GHz} - (<Analysis\_bw> / 2)$$

If any of the conditions no longer apply after you change a setting, the preamplifier is automatically deactivated.

Remote command:

`INPut:GAIN:STATe` on page 128

`INPut:GAIN[:VALue]` on page 128

### Input Coupling ← Input Settings

The RF input of the R&S FSV/A can be coupled by alternating current (AC) or direct current (DC).

AC coupling blocks any DC voltage from the input signal. AC coupling is activated by default to prevent damage to the instrument. Very low frequencies in the input signal can be distorted.

However, some specifications require DC coupling. In this case, you must protect the instrument from damaging DC input voltages manually. For details, refer to the specifications document.

Remote command:

`INPut:COUPling` on page 118

### Impedance ← Input Settings

For some measurements, the reference impedance for the measured levels of the R&S FSV/A can be set to 50 Ω or 75 Ω.

Select 75 Ω if the 50 Ω input impedance is transformed to a higher impedance using a 75 Ω adapter of the RAZ type. (That corresponds to 25Ω in series to the input impedance of the instrument.) The correction value in this case is 1.76 dB = 10 log (75Ω/50Ω).

Remote command:

`INPut:IMPedance` on page 120

### RF Attenuation

Defines the mechanical attenuation for RF input.

#### Attenuation Mode / Value ← RF Attenuation

Defines the attenuation applied to the RF input of the R&S FSV/A.

The RF attenuation can be set automatically as a function of the selected reference level (Auto mode). Automatic attenuation ensures that no overload occurs at the RF Input connector for the current reference level. It is the default setting.

By default and when no (optional) [electronic attenuation](#) is available, mechanical attenuation is applied.

In "Manual" mode, you can set the RF attenuation in 1 dB steps (down to 0 dB). Other entries are rounded to the next integer value. The range is specified in the specifications document. If the defined reference level cannot be set for the defined RF attenuation, the reference level is adjusted accordingly and the warning "limit reached" is displayed.

**NOTICE!** Risk of hardware damage due to high power levels. When decreasing the attenuation manually, ensure that the power level does not exceed the maximum level allowed at the RF input, as an overload can lead to hardware damage.



Remote command:

[INPut:ATTenuation](#) on page 128

[INPut:ATTenuation:AUTO](#) on page 129

### Optimization ← RF Attenuation

Selects the priority for signal processing *after* the RF attenuation has been applied.

This function is only available under the following conditions:

- One of the following options that provide a separate wideband processing path in the R&S FSV/A is installed:  
Bandwidth extension R&S FSV3-B200/-B400
- An I/Q bandwidth that requires the wideband path is used.

"Low distortion"

(Default:) Optimized for low distortion by avoiding intermodulation

"Low noise"

Optimized for high sensitivity and low noise levels

If this setting is selected, "Low noise" is indicated in the channel information bar.

Remote command:

[INPut:ATTenuation:AUTO:MODE](#) on page 127

### Using Electronic Attenuation

If the (optional) Electronic Attenuation hardware is installed on the R&S FSV/A, you can also activate an electronic attenuator.

In "Auto" mode, the settings are defined automatically; in "Manual" mode, you can define the mechanical and electronic attenuation separately.

**Note:** Electronic attenuation is not available for stop frequencies (or center frequencies in zero span) above 7 GHz.

In "Auto" mode, RF attenuation is provided by the electronic attenuator as much as possible to reduce the amount of mechanical switching required. Mechanical attenuation can provide a better signal-to-noise ratio, however.

When you switch off electronic attenuation, the RF attenuation is automatically set to the same mode (auto/manual) as the electronic attenuation was set to. Thus, the RF attenuation can be set to automatic mode, and the full attenuation is provided by the mechanical attenuator, if possible.

The electronic attenuation can be varied in 1 dB steps. If the electronic attenuation is on, the mechanical attenuation can be varied in 5 dB steps. Other entries are rounded to the next lower integer value.

If the defined reference level cannot be set for the given attenuation, the reference level is adjusted accordingly and the warning "limit reached" is displayed in the status bar.

Remote command:

[INPut:EATT:STATE](#) on page 130

[INPut:EATT:AUTO](#) on page 130

[INPut:EATT](#) on page 129

## 5.4 Trigger settings

Access: "Overview" > "Trigger/Gate"

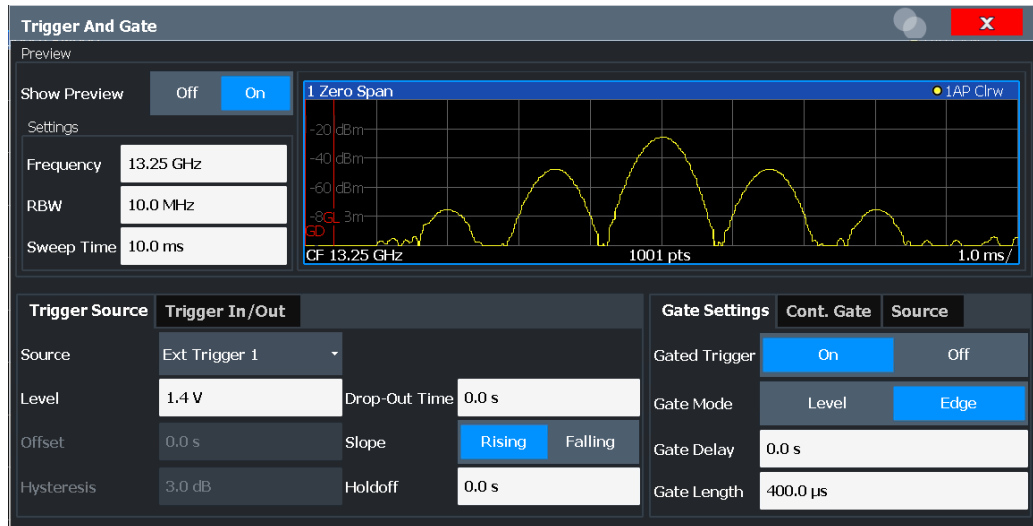

External triggers from one of the Trigger Input / Output connectors on the R&S FSV/A are configured in a separate tab of the dialog box.

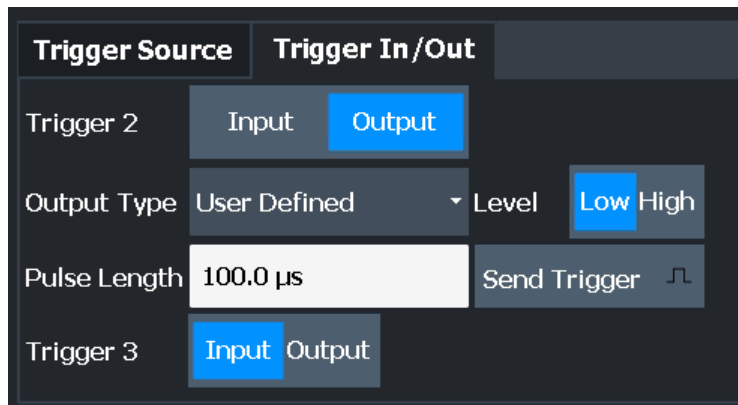

Preview.....	59
L Frequency.....	59
L RBW.....	59
L Sweep Time.....	59
Trigger Source.....	59
L Free Run.....	59
L External Trigger 1/2.....	60
Trigger Level.....	60
Drop-Out Time.....	60
Trigger Offset.....	60
Hysteresis.....	60
Trigger Holdoff.....	61
Slope.....	61

**Preview**

The preview mode allows you to try out trigger and gate settings before actually applying them to the current measurement.

The preview diagram displays a zero span measurement at the center frequency with the defined RBW and sweep time. This is useful when analyzing bursts, for example, to determine the required gate settings.

The trigger and gate settings are applied to the measurement when the dialog box is closed.

**Note:** The zero span settings refer only to the preview diagram. The main diagram remains unchanged.

If preview mode is switched off, any changes to the settings in this dialog box are applied to the measurement diagram directly. In this case, the zero span settings for the preview diagram are not displayed.

**Frequency ← Preview**

Defines the center frequency for the preview diagram.

Remote command:

[\[SENSe:\]FREQuency:CENTer](#) on page 130

**RBW ← Preview**

Defines the resolution bandwidth for the preview diagram. The available resolution bandwidths are specified in the specifications document. Numeric input is always rounded to the nearest possible bandwidth.

Remote command:

[\[SENSe:\]BANDwidth\[:RESolution\]](#) on page 135

**Sweep Time ← Preview**

Defines the sweep time for the preview diagram. Allowed values depend on the ratio of span to RBW and RBW to VBW. For details refer to the specifications document.

Numeric input is always rounded to the nearest possible sweep time.

**Trigger Source**

Selects the trigger source. If a trigger source other than "Free Run" is set, "TRG" is displayed in the channel bar and the trigger source is indicated.

For gated measurements in sweep mode, only external triggers are allowed as the gating trigger source.

**Note:** If the 600 MHz or 1 GHz bandwidth extension options (B600/B601/B1000/B1001) are active, only an external trigger, IF power trigger or no trigger is available for bandwidths  $\geq 400$  MHz. If any other trigger is active and the analysis bandwidth is increased above 400 MHz (thus activating the B600/B601 /B1000/B1001 option), the trigger is automatically deactivated.

Remote command:

[TRIGger\[:SEQuence\]:SOURce](#) on page 135

**Free Run ← Trigger Source**

No trigger source is considered. Data acquisition is started manually or automatically and continues until stopped explicitly.

Remote command:

TRIG:SOUR IMM, see [TRIGger\[:SEquence\]:SOURce](#) on page 135

### External Trigger 1/2 ← Trigger Source

Data acquisition starts when the TTL signal fed into the specified input connector meets or exceeds the specified trigger level.

(See ["Trigger Level"](#) on page 60).

**Note:** "External Trigger 1" automatically selects the trigger signal from the "Trigger 1 Input / Output" connector on the front panel.

For details, see the "Instrument Tour" chapter in the R&S FSV/A Getting Started manual.

"External Trigger 1"

Trigger signal from the "Trigger 1 Input / Output" connector.

"External Trigger 2"

Trigger signal from the "Trigger 2 Input / Output" connector.

Remote command:

TRIG:SOUR EXT, TRIG:SOUR EXT2

See [TRIGger\[:SEquence\]:SOURce](#) on page 135

### Trigger Level

Defines the trigger level for the specified trigger source.

For details on supported trigger levels, see the instrument specifications document.

Remote command:

[TRIGger\[:SEquence\]:LEVel\[:EXTernal<port>\]](#) on page 134

### Drop-Out Time

Defines the time that the input signal must stay below the trigger level before triggering again.

Remote command:

[TRIGger\[:SEquence\]:DTIME](#) on page 133

### Trigger Offset

Defines the time offset between the trigger event and the start of the sweep.

Offset > 0:	Start of the sweep is delayed
Offset < 0:	Sweep starts earlier (pretrigger)

Remote command:

[TRIGger\[:SEquence\]:HOLDoff\[:TIME\]](#) on page 133

### Hysteresis

Defines the distance in dB to the trigger level that the trigger source must exceed before a trigger event occurs. Setting a hysteresis avoids unwanted trigger events caused by noise oscillation around the trigger level.

This setting is only available for "IF Power" trigger sources. The range of the value is between 3 dB and 50 dB with a step width of 1 dB.

Remote command:

[TRIGger\[:SEquence\]:IFPower:HYSteresis](#) on page 133

### Trigger Holdoff

Defines the minimum time (in seconds) that must pass between two trigger events. Trigger events that occur during the holdoff time are ignored.

Remote command:

[TRIGger\[:SEquence\]:IFPower:HOLDoff](#) on page 133

### Slope

For all trigger sources except time, you can define whether triggering occurs when the signal rises to the trigger level or falls down to it.

For gated measurements in "Edge" mode, the slope also defines whether the gate starts on a falling or rising edge.

Remote command:

[TRIGger\[:SEquence\]:SLOPe](#) on page 134

[\[SENSe:\]SWEep:EGATE:POLarity](#) on page 140

## 5.5 Gate settings

**Access:** "Overview" > "Trigger" > "Trigger / Gate Config." > "Gate Settings"

Gate settings define one or more extracts of the signal to be measured.

Gate Settings	Cont. Gate
Gated Trigger	<input checked="" type="radio"/> On <input type="radio"/> Off
Gate Mode	<input type="radio"/> Level <input checked="" type="radio"/> Edge
Gate Delay	0.0 s
Gate Length	400.0 $\mu$ s



Gating is not available for measurements on I/Q-based data.

Gated Trigger.....	62
Gate Mode.....	62
Gate Delay.....	62
Gate Length.....	62

### Gated Trigger

Switches gated triggering on or off.

If the gate is switched on, a gate signal applied to one of the TRIGGER INPUT connectors or the internal IF power trigger controls the sweep.

**Note:** For gated measurements, the maximum RBW is restricted to 3 MHz. If the current RBW is larger when you enable gating, the RBW is automatically reduced to 3 MHz.

For gated measurements in frequency sweep mode, only external triggers and EDGE mode are supported.

Remote command:

[SENSe:] SWEep:EGATe on page 136

### Gate Mode

Sets the gate mode.

For gated measurements in sweep mode, only the "Gate Mode" *Edge* is supported.

"Edge"	The trigger event for the gate to open is the detection of the signal edge. After the gate signal has been detected, the gate remains open until the gate length is over.
"Level"	The trigger event for the gate to open is a particular power level. After the gate signal has been detected, the gate remains open until the signal disappears.

Remote command:

[SENSe:] SWEep:EGATe:TYPE on page 141

### Gate Delay

Defines the delay time between the gate signal and the continuation of the measurement.

Remote command:

[SENSe:] SWEep:EGATe:HOLDoff on page 138

### Gate Length

Defines how long the gate is open when it is triggered.

The gate length can only be set in the edge-triggered gate mode. In the level-triggered mode the gate length depends on the level of the gate signal.

The gate length in relation to the sweep is indicated by a line labeled "GL".

Remote command:

[SENSe:] SWEep:EGATe:LENGth on page 138

## 5.6 Modulation Characteristics measurement settings

**Access:** "Overview" > "Select Measurement" > "Modulation Characteristics"

**Or:** [MEAS] > "Modulation Characteristics"

- [Data acquisition](#).....63
- [Burst and synchronization settings](#)..... 64
- [Demodulation settings](#).....66

### 5.6.1 Data acquisition

**Access:** "Overview" > "Data Acquisition"

**Or:** [MEAS CONFIG] > "Data Acquisition"

The data acquisition settings define how much and how data is captured from the input signal.

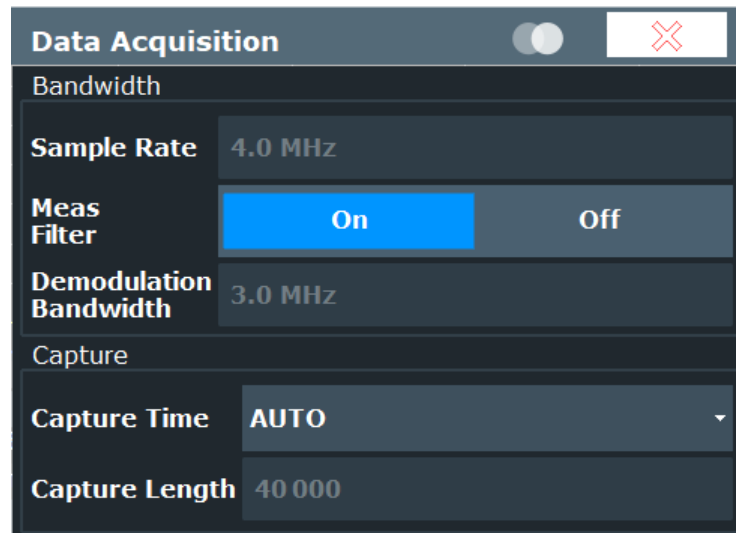

- [Sample rate](#).....63
- [Meas Filter](#)..... 63
- [Demodulation Bandwidth](#)..... 64
- [Capture Time](#).....64
- [Capture Length](#)..... 64

#### Sample rate

The sample rate in MHz. For Bluetooth BR/EDR/LE measurements, the sample rate is always 4 MHz.

#### Meas Filter

Enables or disables the use of an optional measurement filter. See [Chapter 3.2.1, "Measurement filter"](#), on page 30.

Remote command:

CONFigure:BT0oth:MEASurement:FILTer on page 143

**Demodulation Bandwidth**

Indicates the used demodulation bandwidth, depending on whether or not a measurement filter is used. (For reference only).

If the measurement filter is used, the demodulation bandwidth is 1.3 MHz. Otherwise, it is 3 MHz.

Remote command:

[CONFigure:BT0oth:MEASurement:BWIDth?](#) on page 143

**Capture Time**

Defines the packet type used in the Bluetooth BR/EDR/LE signal and thus the required capture time.

The Bluetooth BR/EDR/LE specification defines fixed packet lengths for the basic rate and EDR operating modes (see [Chapter 3.1.1, "Bluetooth packet types for BR/EDR"](#), on page 13). For low energy mode, the packet lengths vary depending on the length of the payload.

"DH1"	Captures one slot
"DH3"	Captures 3 slots
"DH5"	Captures 5 slots
"AUTO"	For BR + EDR: Captures 5 slots
"LE 1M" / "LE 2M" / "LE CODED"	For LE, the R&S FSV3 Bluetooth measurement application determines the required capture time to cover the payload automatically.

Remote command:

[CONFigure:BT0oth:PTYPe](#) on page 144

**Capture Length**

Number of samples captured during one sweep. Indicated for reference only, calculated as [Capture Time](#)\*[Sample rate](#).

**5.6.2 Burst and synchronization settings**

**Access:** "Overview" > "Burst/Sync"

**Or:** [MEAS CONFIG] > "Burst/Sync"

The burst and synchronization settings determine how the R&S FSV3 Bluetooth measurement application tries to find the sync word in the signal and synchronize to it.



Burst/Sync	
UAP (Upper Address Part [hex])	<input type="checkbox"/> Auto 48
LAP (Lower Address Part [hex])	<input type="checkbox"/> Auto 80
Find Sync	<input checked="" type="button" value="On"/> <input type="button" value="Off"/>
Find Burst	<input checked="" type="button" value="On"/> <input type="button" value="Off"/>

UAP (Upper Address Part [hex]).....	65
LAP (Low Address Part [hex]).....	65
Find Sync.....	65
Find Burst.....	66

### UAP (Upper Address Part [hex])

The upper address part of the Bluetooth device address (UAP, the 24 most significant bits) determines the sequence used for the CRC/HEC error correction check. See ["Results Statistics: Measure only if CRC/HEC is correct"](#) on page 73.

By default, the R&S FSV3 Bluetooth measurement application determines the UAP automatically. If "Auto" is disabled, define the UAP manually. The most recently used value is indicated by default. Note that if you change the UAP manually, a new measurement is started.

Not available for LE signals.

Remote command:

[CONFigure:BT0oth:SEARch:SYNC:UAP](#) on page 146

[CONFigure:BT0oth:SEARch:SYNC:UAP:AUTO](#) on page 146

### LAP (Low Address Part [hex])

The lower address part of the Bluetooth device address (LAP, the 24 least significant bits) determines the sync word used for sync search. See ["Synchronization"](#) on page 29.

By default, the R&S FSV3 Bluetooth measurement application determines the LAP automatically. If "Auto" is disabled, define the LAP manually. The most recently used value is indicated by default. Note that if you change the LAP manually, a new measurement is started.

Not available for LE signals.

Remote command:

[CONFigure:BT0oth:SEARch:SYNC:LAP](#) on page 145

[CONFigure:BT0oth:SEARch:SYNC:LAP:AUTO](#) on page 145

### Find Sync

Enables or disables the search for the sync word. The only results that can be determined without synchronization are the output power results. See ["Synchronization"](#) on page 29.

Remote command:

[SENSe:] DDEMod:SEARCh:SYNC:STATe on page 201

#### Find Burst

Enables or disables the search for a signal burst based on the measured power. If both [Find Sync](#) and "Find Burst" are enabled, the search area for the sync word is limited to the detected burst.

Remote command:

[SENSe:] DDEMod:SEARCh:PULSe:STATe on page 200

### 5.6.3 Demodulation settings

**Access:** "Overview" > "Demodulation"

**Or:** [MEAS CONFIG] > "Demod"

The demodulation settings contain the settings required to demodulate the signal.



<a href="#">Packet Bytes SCO</a> .....	66
<a href="#">Antenna Gain</a> .....	66

#### Packet Bytes SCO

Defines the number of payload bytes for SCO packets. SCO packets do not have a payload header.

Remote command:

CONFigure:BT0oth:PBSCo on page 147

#### Antenna Gain

Defines an external gain that the R&S FSV3 Bluetooth measurement application considers for the measurement results.

The value depends on the used standard. See also [Chapter 6.2.1, "Measurement settings depending on standard"](#), on page 83.

Remote command:

[SENSe:]CORRection:EGAIN:INPut[:MAGNitude] on page 147

## 5.7 In-band Spurious Emissions measurement settings

**Access:** "Overview" > "Select Measurement" > "ACP / In-band Spurious Emissions"

**Or:** [MEAS] > "ACP / In-band Spurious Emissions"

## In-band Spurious Emissions measurement settings

All measurement results are based on the transmit (TX) channel and refer to the channel numbers. You can define the TX channel either manually, or according to the channel power levels.

Channel No.....	67
Channel Format.....	67
TX Channel.....	67

### Channel No

**Access:** [MEAS CONFIG] > "Channel No"

Allows you to select the transmit channel within the Bluetooth signal manually. Measurement results are based on this channel.

The currently selected transmit channel is highlighted blue in the result summary table and the diagrams, see [Chapter 4.2, "Result displays for In-band Spurious Emissions measurements"](#), on page 40.

You can step through the individual channels using the rotary knob or arrow keys.

Depending on the [Channel Format](#), the available value range differs.

Remote command:

[CONFigure:BT0oth:CHANnel](#) on page 147

### Channel Format

**Access:** [MEAS CONFIG] > "Channel Format"

Toggles the channel numbers between common TX channel and LE communication channel numbering. The channel format also applies to the ["Number of Captured Channels"](#) on page 86.

This setting is only available for BT LE mode.

"TX" Each channel has a bandwidth of 1 MHz, with channel numbers ranging from 0 to 78.

"LE" Each communication channel has a bandwidth of 2 MHz, with channel numbers ranging from 0 to 40. Non-LE (TX) channels are indicated as fractional channel numbers, e.g. 2.5.

2 Result Summary									
TX Channel:					No of Exceptions:				
Adj Channel Lower: -72.30 dBm					Adj Channel Upper: -72.40 dBm				
					0				
Channel No	Frequency	Power	Limit	Delta Limit	Channel No	Frequency	Power	Limit	Delta Limit
0	2.4010 GHz	-72.75 dBm	-30.00 dBm	42.75 dBc	0.5	2.4020 GHz	-71.09 dBm	-30.00 dBm	41.09 dBc
1	2.4030 GHz	-71.15 dBm	-30.00 dBm	41.15 dBc	1.5	2.4040 GHz	-71.10 dBm	-30.00 dBm	41.10 dBc
2	2.4050 GHz	-71.42 dBm	-30.00 dBm	41.42 dBc	2.5	2.4060 GHz	-71.30 dBm	-30.00 dBm	41.30 dBc
3	2.4070 GHz	-71.60 dBm	-30.00 dBm	41.60 dBc	3.5	2.4080 GHz	-71.40 dBm	-30.00 dBm	41.40 dBc
4	2.4090 GHz	-71.47 dBm	-30.00 dBm	41.47 dBc	4.5	2.4100 GHz	-71.65 dBm	-30.00 dBm	41.65 dBc
5	2.4110 GHz	-71.48 dBm	-30.00 dBm	41.48 dBc	5.5	2.4120 GHz	-71.38 dBm	-30.00 dBm	41.38 dBc
6	2.4130 GHz	-71.78 dBm	-30.00 dBm	41.78 dBc	6.5	2.4140 GHz	-71.69 dBm	-30.00 dBm	41.69 dBc
7	2.4150 GHz	-71.87 dBm	-30.00 dBm	41.87 dBc	7.5	2.4160 GHz	-71.66 dBm	-30.00 dBm	41.66 dBc
8	2.4170 GHz	-71.90 dBm	-30.00 dBm	41.90 dBc	8.5	2.4180 GHz	-71.67 dBm	-30.00 dBm	41.67 dBc
9	2.4190 GHz	-72.07 dBm	-30.00 dBm	42.07 dBc	9.5	2.4200 GHz	-71.70 dBm	-30.00 dBm	41.70 dBc
10	2.4210 GHz	-72.00 dBm	-30.00 dBm	42.00 dBc	10.5	2.4220 GHz	-71.90 dBm	-30.00 dBm	41.90 dBc

Remote command:

[CONFigure:BT0oth:CHFormat](#) on page 148

### TX Channel

**Access:** [MEAS CONFIG] > "TX Channel"

Selects the transmit channel within the Bluetooth signal based on its position in the band.

Select the softkey multiple times to toggle through the settings. The current setting is highlighted.

"Low"	Selects the channel 0.
"Mid"	Selects the channel in the middle of the band (depending on the standard).
"High"	Selects the channel with the highest channel number (depending on the standard).
"Manual"	Selects the channel specified manually by "Channel No" on page 67.

Remote command:

Not available, use `CONFigure:BT0oth:CHANnel` on page 147

## 5.8 Sweep settings

**Access:** [SWEEP]

The sweep settings determine how many sweeps are performed for the measurement.

<a href="#">Continuous Sweep / Run Cont</a> .....	68
<a href="#">Single Sweep / Run Single</a> .....	68
<a href="#">Continue Single Sweep</a> .....	69
<a href="#">Capture Time</a> .....	69
<a href="#">Sweep Count</a> .....	69

### Continuous Sweep / Run Cont

While the measurement is running, "Continuous Sweep" and [RUN CONT] are highlighted. The running measurement can be aborted by selecting the highlighted softkey or key again. The results are not deleted until a new measurement is started.

**Note:** Sequencer. If the Sequencer is active, "Continuous Sweep" only controls the sweep mode for the currently selected channel. However, the sweep mode only takes effect the next time the Sequencer activates that channel, and only for a channel-defined sequence. In this case, a channel in continuous sweep mode is swept repeatedly.

Furthermore, [RUN CONT] controls the Sequencer, not individual sweeps. [RUN CONT] starts the Sequencer in continuous mode.

For details on the Sequencer, see the R&S FSV/A User Manual.

Remote command:

`INITiate<n>:CONTinuous` on page 149

### Single Sweep / Run Single

While the measurement is running, "Single Sweep" and [RUN SINGLE] are highlighted. The running measurement can be aborted by selecting the highlighted softkey or key again.

**Note:** Sequencer. If the Sequencer is active, "Single Sweep" only controls the sweep mode for the currently selected channel. However, the sweep mode only takes effect the next time the Sequencer activates that channel, and only for a channel-defined

sequence. In this case, the Sequencer sweeps a channel in single sweep mode only once.

Furthermore, [RUN SINGLE] controls the Sequencer, not individual sweeps. [RUN SINGLE] starts the Sequencer in single mode.

If the Sequencer is off, only the evaluation for the currently displayed channel is updated.

For details on the Sequencer, see the R&S FSV/A User Manual.

Remote command:

`INITiate<n>[:IMMEDIATE]` on page 150

### Continue Single Sweep

While the measurement is running, "Continue Single Sweep" and [RUN SINGLE] are highlighted. The running measurement can be aborted by selecting the highlighted softkey or key again.

### Capture Time

Defines the packet type used in the Bluetooth BR/EDR/LE signal and thus the required capture time.

The Bluetooth BR/EDR/LE specification defines fixed packet lengths for the basic rate and EDR operating modes (see [Chapter 3.1.1, "Bluetooth packet types for BR/EDR"](#), on page 13). For low energy mode, the packet lengths vary depending on the length of the payload.

"DH1"	Captures one slot
"DH3"	Captures 3 slots
"DH5"	Captures 5 slots
"AUTO"	For BR + EDR: Captures 5 slots
"LE 1M" / "LE 2M" / "LE CODED"	For LE, the R&S FSV3 Bluetooth measurement application determines the required capture time to cover the payload automatically.

Remote command:

`CONFigure:BT0oth:PTYPE` on page 144

### Sweep Count

Defines the number of sweeps that the application uses to average traces. In continuous sweep mode, the application calculates the moving average over the average count. In single sweep mode, the application stops the measurement and calculates the average after the average count has been reached.

The value depends on the used standard. See also [Chapter 6.2.1, "Measurement settings depending on standard"](#), on page 83.

Remote command:

`[SENSe:]SWEep:COUNT` on page 170

## 5.9 Adjusting settings automatically

**Access:** [AUTO SET]

Some settings can be adjusted by the R&S FSV/A automatically according to the current measurement settings. To do so, a measurement is performed. You can configure this measurement.

Setting the Reference Level Automatically (Auto Level).....	70
Resetting the Automatic Measurement Time (Meas Time Auto).....	70
Changing the Automatic Measurement Time (Meas Time Manual).....	70
Upper Level Hysteresis.....	70
Lower Level Hysteresis.....	71

### Setting the Reference Level Automatically (Auto Level)

To determine the required reference level, a level measurement is performed on the R&S FSV/A.

If necessary, you can optimize the reference level further. Decrease the attenuation level manually to the lowest possible value before an overload occurs, then decrease the reference level in the same way.

Remote command:

[\[SENSe:\]ADJust:LEVel](#) on page 143

### Resetting the Automatic Measurement Time (Meas Time Auto)

Resets the measurement duration for automatic settings to the default value.

Remote command:

[\[SENSe:\]ADJust:CONFigure:LEVel:DURation:MODE](#) on page 142

### Changing the Automatic Measurement Time (Meas Time Manual)

This function allows you to change the measurement duration for automatic setting adjustments. Enter the value in seconds.

**Note:** The maximum measurement duration depends on the currently selected measurement and the installed (optional) hardware. Thus, the measurement duration actually used to determine the automatic settings can be shorter than the value you define here.

Remote command:

[\[SENSe:\]ADJust:CONFigure:LEVel:DURation:MODE](#) on page 142

[\[SENSe:\]ADJust:CONFigure:LEVel:DURation](#) on page 141

### Upper Level Hysteresis

When the reference level is adjusted automatically using the [Auto Level](#) function, the internal attenuators and the preamplifier are also adjusted. To avoid frequent adaptation due to small changes in the input signal, you can define a hysteresis. This setting defines an upper threshold that the signal must exceed (compared to the last measurement) before the reference level is adapted automatically.

Remote command:

[\[SENSe:\]ADJust:CONFigure:HYSTeresis:UPPer](#) on page 142

**Lower Level Hysteresis**

When the reference level is adjusted automatically using the [Auto Level](#) function, the internal attenuators and the preamplifier are also adjusted. To avoid frequent adaptation due to small changes in the input signal, you can define a hysteresis. This setting defines a lower threshold that the signal must fall below (compared to the last measurement) before the reference level is adapted automatically.

Remote command:

`[SENSe:]ADJust:CONFigure:HYSTeresis:LOWer` on page 142

## 6 Analysis

**Access:** "Overview" > "Analysis/Limits"

- [Analyzing modulation characteristics](#).....72
- [Analyzing in-band spurious emissions](#).....83
- [Trace / data export configuration](#).....90
- [Working with markers in the R&S FSV3 Bluetooth measurement application](#).....92
- [Display configuration](#).....98

### 6.1 Analyzing modulation characteristics

**Access:** "Overview" > "Select Measurement" > "Modulation Characteristics"

**Or:** [MEAS] > "Modulation Characteristics"

- [BR and LE signals](#).....72
- [EDR signals](#).....79

#### 6.1.1 BR and LE signals

- [Power range for analysis](#).....72
- [Checking limits \(BR\)](#).....74
- [Checking limits \(LE\)](#).....76

##### 6.1.1.1 Power range for analysis

**Access:** "Overview" > "Analysis / Limits"

**Or:** [MEAS CONFIG] > "Analysis"

The core specification of Bluetooth wireless technology defines the limits of output power levels for the maximum power. The maximum power is determined by a percentage of the power range, which corresponds to the burst length.



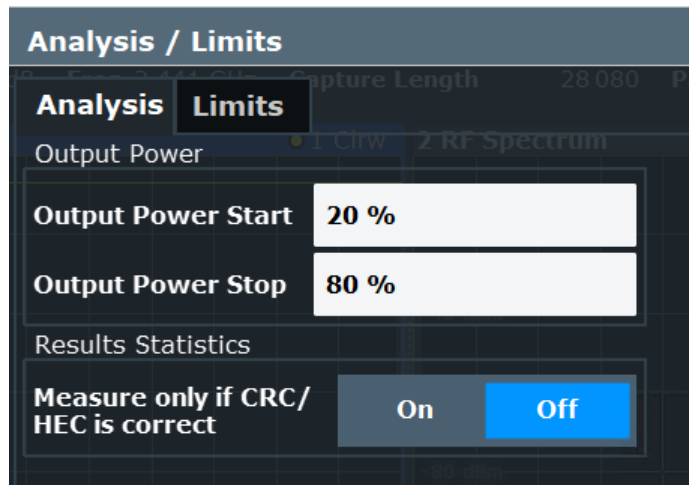

### Output Power Start / Output Power Stop

Start and stop positions of the power range in which the average maximum power is determined. Defined as percentages of the burst length. See also "Output power" on page 13.

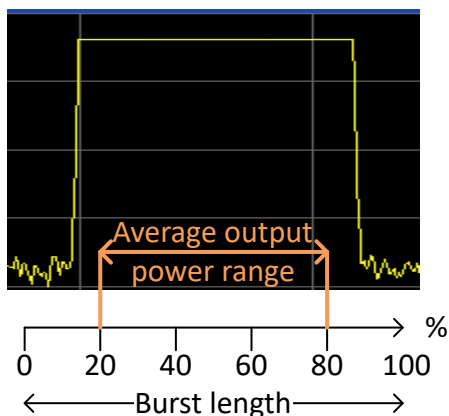

Remote command:

[CONFigure:BT0oth:POWer:AVERage:STARt](#) on page 152

[CONFigure:BT0oth:POWer:AVERage:STOP](#) on page 153

### Results Statistics: Measure only if CRC/HEC is correct

If enabled, only packets which pass the CRC/HEC error correction check are considered for statistical results. By default, this function is disabled and all bursts are included in the result statistics.

The CRC/HEC error correction check requires the [UAP \(Upper Address Part \[hex\]\)](#), see [Chapter 5.6.2, "Burst and synchronization settings"](#), on page 64.

The number of packets that passed the CRC/HEC error correction check is indicated in the "Result Summary". See [Table 4-1](#).

This function is only available for Basic Rate signals.

Remote command:

[CONFigure:BT0oth:CRc:MOPass](#) on page 153

### 6.1.1.2 Checking limits (BR)

**Access:** "Overview" > "Analysis / Limits" > "Limits"

**Or:** [MEAS CONFIG] > "Analysis / Limits" > "Limits"

By default, the measured Bluetooth signal characteristics are checked against the limits defined in the specification. However, you can define your own limits to check the results against.

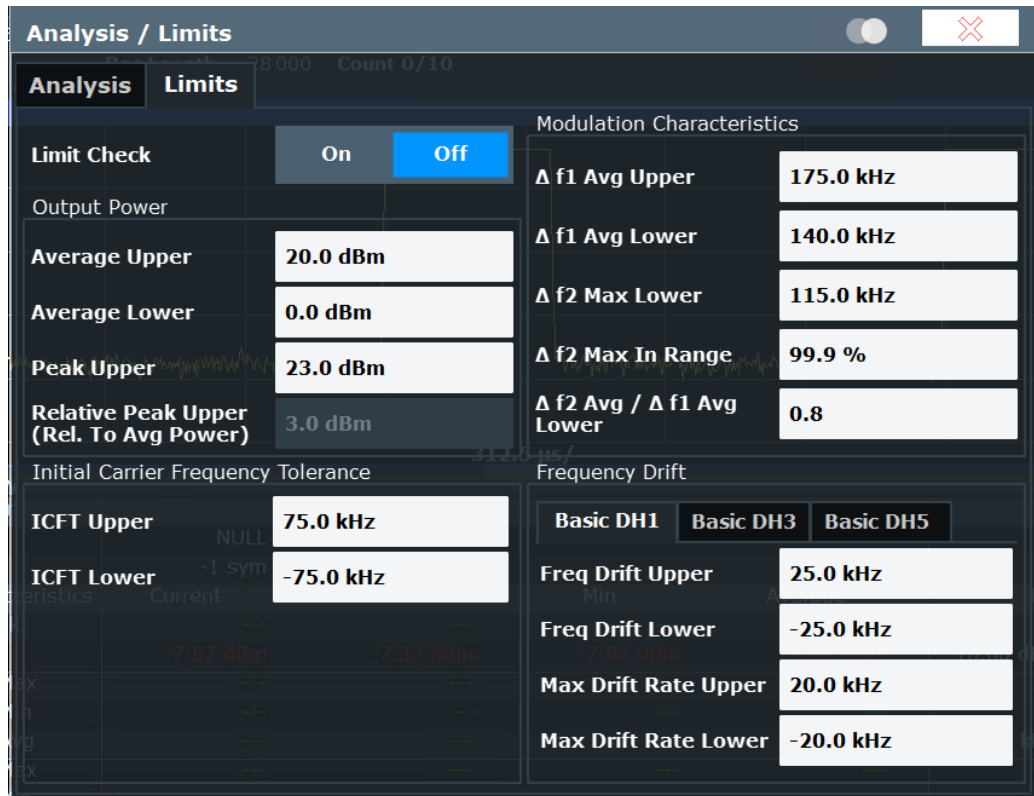

Limit Check.....	74
Average Upper/ Average Lower.....	75
Peak Upper.....	75
Relative Peak Upper (Rel. to Avg Power).....	75
ICFT Upper / ICFT Lower.....	75
$\Delta f1$ Avg Upper / $\Delta f1$ Avg Lower.....	75
$\Delta f2$ Max Lower.....	75
$\Delta f2$ Max In Range.....	75
$\Delta f2$ Avg / $\Delta f1$ Avg Lower.....	75
Frequency Drift.....	76
└ Freq Drift Upper / Freq Drift Lower.....	76
└ Max Drift Rate Upper / Max Drift Rate Lower.....	76

#### Limit Check

Enables or disables a limit check for the measured results.

Remote command:

CALCulate<n>:LIMit:TRACe<t>:CHECK on page 154

**Average Upper/ Average Lower**

Defines the upper/lower limit for the average output power.

Remote command:

[CONFigure:BT0oth:POWer:AVERAge:ULIMit](#) on page 161

[CONFigure:BT0oth:POWer:AVERAge:LLIMit](#) on page 161

**Peak Upper**

Defines the upper limit for the peak output power.

Remote command:

[CONFigure:BT0oth:POWer:PEAK:ULIMit](#) on page 162

**Relative Peak Upper (Rel. to Avg Power)**

Indicates the (calculated) limit for the peak output power relative to the average output power.

Remote command:

[CONFigure:BT0oth:POWer:PEAK:RLIMit](#) on page 162

**ICFT Upper / ICFT Lower**

Defines the upper/lower limit for the initial carrier frequency tolerance (ICFT) in BR signals.

Remote command:

[CONFigure:BT0oth:ICFTolerance:ULIMit](#) on page 157

[CONFigure:BT0oth:ICFTolerance:LLIMit](#) on page 157

 **$\Delta f_1$  Avg Upper /  $\Delta f_1$  Avg Lower**

Defines the upper/lower limit for the average frequency offset for the first test sequence (00001111).

Remote command:

[CONFigure:BT0oth:MODulation:F1AVERAGE:ULIMit](#) on page 159

[CONFigure:BT0oth:MODulation:F1AVERAGE:LLIMit](#) on page 159

 **$\Delta f_2$  Max Lower**

Defines the lower limit for the maximum frequency offset for the second test sequence (01010101).

Remote command:

[CONFigure:BT0oth:MODulation:F2Max:LLIMit](#) on page 161

 **$\Delta f_2$  Max In Range**

Percentage of the maximum frequency offset measurements that remained within the valid range (did not exceed the limits)

Remote command:

[CONFigure:BT0oth:MODulation:F2Max:IRANge](#) on page 160

 **$\Delta f_2$  Avg /  $\Delta f_1$  Avg Lower**

Defines the lower limit for the ratio of average f2 offset to average f1 offset (not available for LE Coded).

Remote command:

`CONFigure:BT0oth:MODulation:FDIVision:LLIMit` on page 160

### Frequency Drift

The frequency drift limits are defined individually for each packet type.

#### Freq Drift Upper / Freq Drift Lower ← Frequency Drift

Defines the upper/lower limit for the frequency drift.

Remote command:

BR:

`CONFigure:BT0oth:DH<pt>:FDRift:ULIMit` on page 155

`CONFigure:BT0oth:DH<pt>:FDRift:LLIMit` on page 154

LE:

`CONFigure:BT0oth:FDRift:ULIMit` on page 156

`CONFigure:BT0oth:FDRift:LLIMit` on page 156

#### Max Drift Rate Upper / Max Drift Rate Lower ← Frequency Drift

Defines the upper/lower limit for the maximum frequency drift per packet.

Remote command:

BR:

`CONFigure:BT0oth:DH<pt>:MDRate:ULIMit` on page 155

`CONFigure:BT0oth:DH<pt>:MDRate:LLIMit` on page 155

LE:

`CONFigure:BT0oth:MDRate:ULIMit` on page 159

`CONFigure:BT0oth:MDRate:LLIMit` on page 158

### 6.1.1.3 Checking limits (LE)

**Access:** "Overview" > "Analysis / Limits" > "Limits"

**Or:** [MEAS CONFIG] > "Analysis / Limits" > "Limits"

By default, the measured Bluetooth signal characteristics are checked against the limits defined in the specification. However, you can define your own limits to check the results against. Note that the limits differ depending on the used transmission mode (PHY).

Analysis / Limits		Modulation Characteristics	
<b>Limit Check</b>	<input checked="" type="checkbox"/> On <input type="checkbox"/> Off	<b>Δ f1 Avg Upper</b>	275.0 kHz
Output Power		<b>Δ f1 Avg Lower</b>	225.0 kHz
<b>Average Upper</b>	10.0 dBm	<b>Δ f1 Max Lower</b>	185.0 kHz
<b>Average Lower</b>	-20.0 dBm	<b>Δ f1 Max In Range</b>	99.9 %
<b>Peak Upper</b>	23.0 dBm	<b>Δ f2 Avg / Δ f1 Avg Lower</b>	0.8
<b>Relative Peak Upper (Rel. To Avg Power)</b>	3.0 dBm	Frequency Drift	
Frequency Offset		<b>Freq Drift Upper</b>	50.0 kHz
<b>Freq Offset Upper</b>	150.0 kHz	<b>Freq Drift Lower</b>	-50.0 kHz
<b>Freq Offset Lower</b>	-150.0 kHz	<b>Max Drift Rate Upper</b>	20.0 kHz
		<b>Max Drift Rate Lower</b>	-20.0 kHz
		<b>Initial Freq Drift Upper</b>	23.0 kHz
		<b>Initial Freq Drift Lower</b>	-23.0 kHz

Limit Check.....	77
Average Upper/ Average Lower.....	77
Peak Upper.....	78
Relative Peak Upper (Rel. to Avg Power).....	78
Freq Offset Upper / Lower.....	78
Δf1 Avg Upper / Δf1 Avg Lower.....	78
Δf2 Max Lower.....	78
Δf1 Max Lower (LE Coded).....	78
Δf2 Max In Range.....	78
Δf1 Max In Range (LE Coded).....	79
Δf2 Avg / Δf1 Avg Lower.....	79
Frequency Drift.....	79
└ Freq Drift Upper / Freq Drift Lower.....	79
└ Max Drift Rate Upper / Max Drift Rate Lower.....	79
└ Initial Freq Drift Upper / Initial Freq Drift Lower.....	79

### Limit Check

Enables or disables a limit check for the measured results.

Remote command:

CALCulate<n>:LIMit:TRACe<t>:CHECK on page 154

### Average Upper/ Average Lower

Defines the upper/lower limit for the average output power.

Remote command:

[CONFigure:BT0oth:POWer:AVERage:ULIMit](#) on page 161

[CONFigure:BT0oth:POWer:AVERage:LLIMit](#) on page 161

### Peak Upper

Defines the upper limit for the peak output power.

Remote command:

[CONFigure:BT0oth:POWer:PEAK:ULIMit](#) on page 162

### Relative Peak Upper (Rel. to Avg Power)

Indicates the (calculated) limit for the peak output power relative to the average output power.

Remote command:

[CONFigure:BT0oth:POWer:PEAK:RLIMit](#) on page 162

### Freq Offset Upper / Lower

Defines the upper/lower limit for the frequency offset.

Remote command:

[CONFigure:BT0oth:F0FFset:ULIMit](#) on page 157

[CONFigure:BT0oth:F0FFset:LLIMit](#) on page 156

### $\Delta f_1$ Avg Upper / $\Delta f_1$ Avg Lower

Defines the upper/lower limit for the average frequency offset for the first test sequence (00001111).

Remote command:

[CONFigure:BT0oth:MODulation:F1AVerage:ULIMit](#) on page 159

[CONFigure:BT0oth:MODulation:F1AVerage:LLIMit](#) on page 159

### $\Delta f_2$ Max Lower

Defines the lower limit for the maximum frequency offset for the second test sequence (01010101).

Remote command:

[CONFigure:BT0oth:MODulation:F2Max:LLIMit](#) on page 161

### $\Delta f_1$ Max Lower (LE Coded)

Defines the lower limit for the maximum frequency offset for the first test sequence (for LE Coded).

Remote command:

[CONFigure:BT0oth:MODulation:F1Max:LLIMit](#) on page 160

### $\Delta f_2$ Max In Range

Percentage of the maximum frequency offset measurements that remained within the valid range (did not exceed the limits)

Remote command:

[CONFigure:BT0oth:MODulation:F2Max:IRANge](#) on page 160

**$\Delta f_1$  Max In Range (LE Coded)**

Percentage of the maximum frequency offset measurements that remained within the valid range (did not exceed the limits) for LE Coded.

Remote command:

[CONFigure:BT0oth:MODulation:F1Max:IRANge](#) on page 160

 **$\Delta f_2$  Avg /  $\Delta f_1$  Avg Lower**

Defines the lower limit for the ratio of average f2 offset to average f1 offset (not available for LE Coded).

Remote command:

[CONFigure:BT0oth:MODulation:FDIVision:LLIMit](#) on page 160

**Frequency Drift**

The frequency drift limits are defined individually for each packet type.

**Freq Drift Upper / Freq Drift Lower ← Frequency Drift**

Defines the upper/lower limit for the frequency drift.

Remote command:

BR:

[CONFigure:BT0oth:DH<pt>:FDRift:ULIMit](#) on page 155

[CONFigure:BT0oth:DH<pt>:FDRift:LLIMit](#) on page 154

LE:

[CONFigure:BT0oth:FDRift:ULIMit](#) on page 156

[CONFigure:BT0oth:FDRift:LLIMit](#) on page 156

**Max Drift Rate Upper / Max Drift Rate Lower ← Frequency Drift**

Defines the upper/lower limit for the maximum frequency drift per packet.

Remote command:

BR:

[CONFigure:BT0oth:DH<pt>:MDRate:ULIMit](#) on page 155

[CONFigure:BT0oth:DH<pt>:MDRate:LLIMit](#) on page 155

LE:

[CONFigure:BT0oth:MDRate:ULIMit](#) on page 159

[CONFigure:BT0oth:MDRate:LLIMit](#) on page 158

**Initial Freq Drift Upper / Initial Freq Drift Lower ← Frequency Drift**

Defines the upper/lower limit for the initial frequency drift.

Remote command:

[CONFigure:BT0oth:IFDRift:ULIMit](#) on page 158

[CONFigure:BT0oth:IFDRift:LLIMit](#) on page 158

**6.1.2 EDR signals**

- [Evaluation range](#)..... 80
- [Checking limits \(EDR\)](#)..... 80

### 6.1.2.1 Evaluation range

**Access:** "Overview" > "Analysis / Limits"

**Or:** [MEAS CONFIG] > "Analysis"

For EDR signals, the relative transmit power is measured. It is calculated as the ratio of the average transmission power of the GFSK and DPSK-modulated parts of the signal. (GFSK stands for Gaussian Frequency Shift Keying, while DPSK stands for Differential Phase Shift Keying.) To determine the transmit power values, you must configure the percentage of the measurement time in which the corresponding modulation type is used.

Analysis / Limits	
Analysis	Limits
Output Power GFSK	
GFSK Power Start	10 %
GFSK Power Stop	90 %
Output Power DPSK	
DPSK Power Start	10 %
DPSK Power Stop	90 %

GFSK Power Start / GFSK Power Stop.....	80
DPSK Power Start / DPSK Power Stop.....	80

#### GFSK Power Start / GFSK Power Stop

Defines the percentage of the total measurement time at which the power measurement of the GFSK-modulated part of the signal starts and stops.

Remote command:

[CONFigure:BT0oth:RTPower:GAverage:START](#) on page 163

[CONFigure:BT0oth:RTPower:GAverage:STOP](#) on page 163

#### DPSK Power Start / DPSK Power Stop

Defines the percentage of the total measurement time at which the power measurement of the DPSK-modulated part of the signal starts and stops.

Remote command:

[CONFigure:BT0oth:RTPower:DAverage:START](#) on page 163

[CONFigure:BT0oth:RTPower:DAverage:STOP](#) on page 163

### 6.1.2.2 Checking limits (EDR)

**Access:** "Overview" > "Analysis / Limits" > "Limits"

**Or:** [MEAS CONFIG] > "Analysis / Limits" > "Limits"



By default, the measured Bluetooth signal characteristics are checked against the limits defined in the specification. However, you can define your own limits to check the results against.

Carrier Stability		Modulation Accuracy - DEVM Upper	
Initial Freq Offset Upper	75.0 kHz	RMS DQPSK	20.0 %
Lower	-75.0 kHz	8PSK	13.0 %
Block Freq Offset Upper	10.0 kHz	Peak DQPSK	35.0 %
Lower	-10.0 kHz	8PSK	25.0 %
Total Freq Offset Upper	75.0 kHz	99% DQPSK	30.0 %
Lower	-75.0 kHz	8PSK	20.0 %

Relative TX Power	
Rel Avg Power Upper	1.0 dB
Lower	-4.0 dB

Limit Check.....	81
Carrier Stability.....	81
L Initial Freq Offset Upper / Lower.....	81
L Block Freq Offset Upper / Lower.....	82
L Total Freq Offset Upper / Lower.....	82
Modulation Accuracy - DEVM Upper.....	82
L RMS DQPSK / 8PSK.....	82
L Peak DQPSK / 8PSK.....	82
L 99% DQPSK / 8PSK.....	82
Rel. Avg Power Upper / Lower.....	82

### Limit Check

Enables or disables a limit check for the measured results.

Remote command:

[CALCulate<n>:LIMIT:TRACe<t>:CHECK](#) on page 154

### Carrier Stability

The carrier stability measurement verifies that the modulation accuracy and the frequency stability are within the required limits.

#### Initial Freq Offset Upper / Lower ← Carrier Stability

Defines the upper/lower limit of the initial frequency offset.

Remote command:

[CONFigure:BT0oth:CFSTability:IFRequency:ULIMit](#) on page 165

[CONFigure:BT0oth:CFSTability:IFRequency:LLIMit](#) on page 165

#### **Block Freq Offset Upper / Lower ← Carrier Stability**

Defines the upper/lower limit of the block frequency offset.

Remote command:

[CONFigure:BT0oth:CFSTability:BFRequency:ULIMit](#) on page 164

[CONFigure:BT0oth:CFSTability:BFRequency:LLIMit](#) on page 164

#### **Total Freq Offset Upper / Lower ← Carrier Stability**

Defines the upper/lower limit of the total frequency offset.

Remote command:

[CONFigure:BT0oth:CFSTability:TFRequency:ULIMit](#) on page 166

[CONFigure:BT0oth:CFSTability:TFRequency:LLIMit](#) on page 165

#### **Modulation Accuracy - DEVM Upper**

Differential error vector magnitude

#### **RMS DQPSK / 8PSK ← Modulation Accuracy - DEVM Upper**

Defines the upper limit for the RMS DEVM for the DQPSK-/8PSK-modulated part of the signal.

Remote command:

[CONFigure:BT0oth:MODulation:RDQPsk:ULIMit](#) on page 168

[CONFigure:BT0oth:MODulation:R8PSk:ULIMit](#) on page 167

#### **Peak DQPSK / 8PSK ← Modulation Accuracy - DEVM Upper**

Defines the upper limit for the peak DEVM for the DQPSK-/8PSK-modulated part of the signal.

Remote command:

[CONFigure:BT0oth:MODulation:PDQPsk:ULIMit](#) on page 167

[CONFigure:BT0oth:MODulation:P8PSk:ULIMit](#) on page 166

#### **99% DQPSK / 8PSK ← Modulation Accuracy - DEVM Upper**

Defines the upper limit for the 99-percentile DEVM for the DQPSK-/8PSK-modulated part of the signal.

Remote command:

[CONFigure:BT0oth:MODulation:DQ99:ULIMit](#) on page 166

[CONFigure:BT0oth:MODulation:PS99:ULIMit](#) on page 167

#### **Rel. Avg Power Upper / Lower**

Defines the upper/lower limit of the relative average TX power.

Remote command:

[CONFigure:BT0oth:RTPower:ULIMit](#) on page 168

[CONFigure:BT0oth:RTPower:LLIMit](#) on page 168

## 6.2 Analyzing in-band spurious emissions

**Access:** "Overview" > "Select Measurement" > "In-band Spurious Emissions"

**Or:** [MEAS] > "In-band Spurious Emissions"

- [Measurement settings depending on standard](#).....83
- [Measurement settings](#).....84
- [Saving and loading predefined settings](#)..... 87
- [Checking limits](#).....88
- [Result configuration](#)..... 90

### 6.2.1 Measurement settings depending on standard

Several measurement settings related to the number of channels in the Bluetooth signal differ depending on the used standard. In addition, the specifications for in-band spurious emissions measurements differ for France and the rest of the world. Thus, to check the measurement results against limits for a particular standard, you must define the geographical location to consider (see "[Geography](#)" on page 85). [Table 6-1](#) and [Table 6-2](#) indicate the used or allowed values for different standards. For details on the parameters, see [Chapter 6.2.2, "Measurement settings"](#), on page 84.

**Table 6-1: In-band spurious emissions measurement settings depending on used standard (France)**

Parameter	Used/allowed values		
	Default	Min	Max
<b>BR/EDR</b>			
Center frequency	2.465 GHz	device-specific	
Frequency stepsize	1 MHz	1 MHz	10 MHz
Captured no. of channels	23	3	23
Sweep count	10	1	100
Antenna gain	0 dB	0 dB	200 dB
<b>LE</b>			
Center frequency	2.465 GHz	device-specific	
Frequency stepsize	2 MHz	2 MHz	10 MHz
Captured no. of channels	23	3	23
Sweep count	10	1	100
Antenna gain	0 dB	0 dB	200 dB

**Table 6-2: In-band spurious emissions measurement settings depending on used standard (other)**

Parameter	Used/allowed values		
	Default	Min	Max
<b>BR/EDR</b>			
Center frequency	2.441 GHz	device-specific	
Frequency stepsize	1 MHz	1 MHz	10 MHz
Captured no. of channels	79	3	79
Sweep count	10	1	100
Antenna gain	0 dB	0 dB	200 dB
<b>LE</b>			
Center frequency	2.441 GHz	device-specific	
Frequency stepsize	2 MHz	2 MHz	10 MHz
Captured no. of channels	81	3	81
Sweep count	10	1	100
Antenna gain	0 dB	0 dB	200 dB

## 6.2.2 Measurement settings

**Access:** "Overview" > "Analysis"

**Or:** [MEAS CONFIG] > "Analysis"

Define the measurement settings depending on the used standard.

### Analysis / Limits

**Analysis**
**Limits**

Geography

France
Other

Frequency Settings

**Center Frequency**
2.45 GHz

**Frequency Stepsize**
1.0 MHz

Predefined Settings

Load Predefined Settings

Save Predefined Settings

Measurement Settings

<b>Number of Captured Channels</b>	79
<b>Capture Time</b>	100.0 ms
<b>Sweep Count</b>	10
<b>Antenna Gain</b>	0.0 dB



You can save and load predefined settings for commonly used scenarios. See [Chapter 6.2.3, "Saving and loading predefined settings"](#), on page 87.

Geography.....	85
Center Frequency.....	86
Frequency Stepsize.....	86
Number of Captured Channels.....	86
Capture Time.....	86
Sweep Count.....	86
Antenna Gain.....	86

### Geography

The specifications for in-band spurious emissions measurements differ for France and the rest of the world. Thus, to check the measurement results against limits for a particular standard, you must define the geographical location to consider. See also [Chapter 6.2.1, "Measurement settings depending on standard"](#), on page 83.

Remote command:

CONFigure:BT0oth:IBSemissions:GEOGraphy on page 171

**Center Frequency**

Indicates the center frequency (frequency domain) or measuring frequency (time domain).

The value depends on the used standard. See also [Chapter 6.2.1, "Measurement settings depending on standard"](#), on page 83.

Remote command:

`[SENSe:] FREQuency:CENTer` on page 169

**Frequency Stepsize**

Indicates the step size by which the center frequency is increased or decreased when the arrow keys are pressed. When you use the rotary knob, the center frequency changes in much smaller steps (1/10 the size as for the arrow keys).

The value depends on the used standard. See also [Chapter 6.2.1, "Measurement settings depending on standard"](#), on page 83.

Remote command:

`[SENSe:] FREQuency:CENTer:STEP` on page 169

**Number of Captured Channels**

Defines the number of channels that are captured by the in-band spurious emissions measurement. The channel number format depends on the ["Channel Format"](#) on page 67. The number of captured channels must be an odd number.

The value depends on the used standard. See also [Chapter 6.2.1, "Measurement settings depending on standard"](#), on page 83.

Remote command:

`CONFigure:BT0oth:IBSeissions:NCHannels` on page 171

**Capture Time**

Defines the required capture time.

Remote command:

`[SENSe:] SWEEp:TIME` on page 171

**Sweep Count**

Defines the number of sweeps that the application uses to average traces. In continuous sweep mode, the application calculates the moving average over the average count. In single sweep mode, the application stops the measurement and calculates the average after the average count has been reached.

The value depends on the used standard. See also [Chapter 6.2.1, "Measurement settings depending on standard"](#), on page 83.

Remote command:

`[SENSe:] SWEEp:COUNT` on page 170

**Antenna Gain**

Defines an external gain that the R&S FSV3 Bluetooth measurement application considers for the measurement results.

The value depends on the used standard. See also [Chapter 6.2.1, "Measurement settings depending on standard"](#), on page 83.

Remote command:

[SENSe:]CORRection:EGain:INPut[:MAGNitude] on page 147

## 6.2.3 Saving and loading predefined settings

**Access:** "Analysis"

For commonly performed measurements, standard setup files are provided for quick and easy configuration. Simply load an existing standard settings file and, if necessary, adapt the measurement settings to your specific requirements. In addition, you can create your own settings files for user-specific analysis.

For details on the available files, see [Chapter A, "Predefined standards and settings"](#), on page 205.

<a href="#">Load Predefined Settings</a> .....	87
<a href="#">Save Predefined Settings</a> .....	87
<a href="#">Selecting Storage Location - Drive/ Path/ Files</a> .....	87
<a href="#">File Name</a> .....	87

### Load Predefined Settings

Loads the selected measurement settings file.

For an overview of predefined standards and settings, see [Chapter A, "Predefined standards and settings"](#), on page 205.

Remote command:

CONFigure:BT0oth:LOAD on page 171

### Save Predefined Settings

Saves the current measurement settings for a specific standard as a file with the defined name.

For an overview of predefined standards and settings, see [Chapter A, "Predefined standards and settings"](#), on page 205.

Remote command:

CONFigure:BT0oth:STORe on page 172

### Selecting Storage Location - Drive/ Path/ Files

Select the storage location of the file on the instrument or an external drive.

**Note:** Saving instrument settings in secure user mode.

In secure user mode, settings that are stored on the instrument are stored to volatile memory, which is restricted to 256 MB. Thus, a "memory limit reached" error can occur although the hard disk indicates that storage space is still available.

To store data permanently, select an external storage location such as a USB memory device.

For details, see "Protecting Data Using the Secure User Mode" in the "Data Management" section of the R&S FSV3000/ FSVA3000 base unit user manual.

### File Name

Contains the name of the data file without the path or extension.

File names must be compatible with the Windows conventions for file names. In particular, they must not contain special characters such as ":", "\*", "?".

### 6.2.4 Checking limits

**Access:** "Overview" > "Limits"

**Or:** [MEAS CONFIG] > "Limits"

The Bluetooth BR/EDR/LE standard defines the limits to check the measured channel power levels against. The limits are predefined in the R&S FSV3 Bluetooth measurement application according to the selected [Standard](#). However, you can change the settings for customized evaluation. Note that not all limits are available for all standards.



All limits are defined in relation to the currently selected TX channel (see ["TX Channel"](#) on page 67).

**Analysis / Limits**

**Analysis** | **Limits**

Limit Check:  On  Off

Allowed Exceptions: 3

Relative Limit |M-N| = 1: -26.0 dB

Near Limit |M-N| = 2: -20.0 dBm

Far Limit |M-N| ≥ 3: -30.0 dBm

Frequency Offset 2 MHz: -20.0 dBm

Frequency Offset 4 MHz: -20.0 dBm

Frequency Offset 5 MHz: -20.0 dBm

Bluetooth Band diagram showing Tx Channel and other channels (|M-N|=1, 2, 3) relative to Center Frequency and f [Hz].



The limit line, defined by concatenating the specified limits for the different channels, is displayed in the ["ACP / In-band Spurious Emissions"](#) on page 40.

[Limit Check](#)..... 89

[Allowed Exceptions](#)..... 89

[Relative Limit](#)..... 89



Near Limit.....	89
Far Limit.....	89
Limits for channels at frequency offsets.....	89

### Limit Check

Enables or disables a limit check for the measured results.

Remote command:

[CALCulate<n>:LIMit:TRACe<t>:CHECK](#) on page 154

### Allowed Exceptions

Defines the number of acceptable exceptions for the limit check to be considered passed. Limit violations by adjacent or alternate1 channels are never allowed. If such a violation occurs, the limit check is automatically failed.

Remote command:

[CONFigure:BT0oth:IBSEmissions:NFAilures](#) on page 173

### Relative Limit

Maximum power in the adjacent channel.

**Note:** Limit violations by adjacent channels are never allowed (see "[Allowed Exceptions](#)" on page 89). If such a violation occurs, the limit check is automatically failed.

This setting is only available for BT EDR mode.

Remote command:

[CONFigure:BT0oth:IBSEmissions:RLIMit](#) on page 174

### Near Limit

Maximum power in the first alternate channel.

**Note:** Limit violations by alternate1 channels are never allowed (see "[Allowed Exceptions](#)" on page 89). If such a violation occurs, the limit check is automatically failed.

This setting is not available for BT LE mode.

Remote command:

[CONFigure:BT0oth:IBSEmissions:NLIMit](#) on page 174

### Far Limit

Maximum power in the second or further alternate channels.

Remote command:

[CONFigure:BT0oth:IBSEmissions:FLIMit](#) on page 172

### Limits for channels at frequency offsets

Defines the maximum power in channels at a specified frequency offset from the transmit frequency.

This setting is only available for BT LE mode.

"2 MHz"	For LE 1M and LE coded only
"4 MHz"	For LE 2M only
"5 MHz"	For LE 2M only

Remote command:

[CONFigure:BT0oth:IBSEmissions:L2MHz](#) on page 173

[CONFigure:BT0oth:IBSEmissions:L4MHz](#) on page 173

[CONFigure:BT0oth:IBSEmissions:L5MHz](#) on page 173

## 6.2.5 Result configuration

**Access:** [MEAS CONFIG] > "Result Config"

You can define which parameters are displayed in the "Result summary".

By default, all available parameters are displayed.

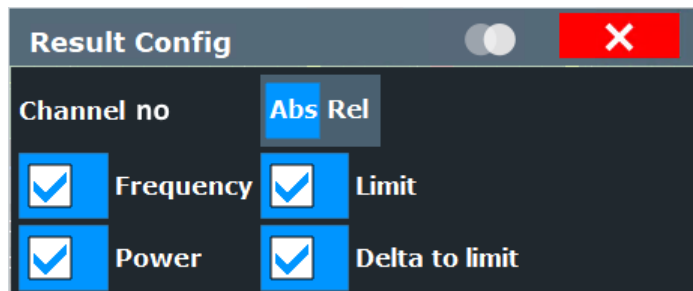

**Frequency/Power/Limit/Delta to Limit**

Only selected parameters are displayed.

For details on the parameters, see ["Result Summary"](#) on page 41.

Remote command:

[DISPlay\[:WINDow<n>\]:TABLE:ITEM](#) on page 174

**Channel Number Abs/Rel**

Indicates the channel number in absolute numbers or relative to the TX channel (see ["Channel No"](#) on page 67)

Remote command:

[DISPlay\[:WINDow<n>\]:TABLE:ITEM](#) on page 174

## 6.3 Trace / data export configuration



**Access:** "Save" > "Export" > "Export Configuration"

**Or:** [TRACE] > "Trace Config" > "Trace / Data Export"

The R&S FSV/A provides various evaluation methods for the results of the performed measurements. However, if you want to evaluate the data with other, external applications, you can export the measurement data to an ASCII file.



The standard data management functions (e.g. saving or loading instrument settings) that are available for all R&S FSV/A applications are not described here.

See the R&S FSV3000/ FSVA3000 base unit user manual for a description of the standard functions.

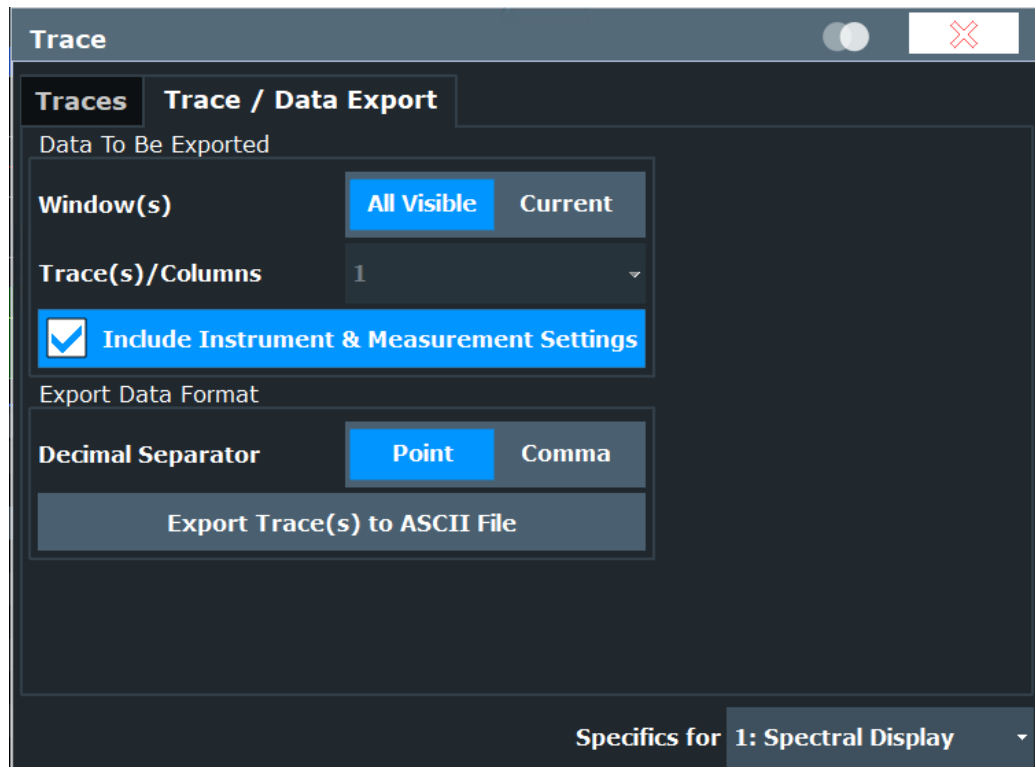

Selecting data to export.....	91
Include Instrument & Measurement Settings.....	91
Decimal Separator.....	92
Export Trace to ASCII File.....	92

### Selecting data to export

"Window(s)" selects the data that you want to export.

"All Visible" exports all traces in all result displays that are currently visible.

"Current" exports the traces in the currently selected (highlighted blue) result display.

If you export data from the currently selected result display, you can also select if you want to export all traces in that result display, or a single trace only from the "Trace(s) / Columns" dropdown menu.

Remote command:

[MMEMory: STORe<n>: TRACe](#) on page 196

### Include Instrument & Measurement Settings

Includes additional instrument and measurement settings in the header of the export file for result data.

Remote command:

[FORMat:DEXPort:HEADer](#) on page 196

### Decimal Separator

Defines the decimal separator for floating-point numerals for the data export/import files. Evaluation programs require different separators in different languages.

Remote command:

[FORMat:DEXPort:DSEParator](#) on page 195

### Export Trace to ASCII File

Opens a file selection dialog box and saves the selected trace in ASCII format (.dat) to the specified file and directory.

The results are output in the same order as they are displayed on the screen: window by window, trace by trace, and table row by table row.

**Note:** Secure user mode.

In secure user mode, settings that are stored on the instrument are stored to volatile memory, which is restricted to 256 MB. Thus, a "memory limit reached" error can occur although the hard disk indicates that storage space is still available.

To store data permanently, select an external storage location such as a USB memory device.

For details, see "Protecting Data Using the Secure User Mode" in the "Data Management" section of the R&S FSV3000/ FSVA3000 base unit user manual.

Remote command:

[MMEMory:STORe<n>:TRACe](#) on page 196

## 6.4 Working with markers in the R&S FSV3 Bluetooth measurement application

**Access:** "Overview" > "Analysis"

Markers help you analyze your measurement results by determining particular values in the diagram. Thus you can extract numeric values from a graphical display.

- [Marker settings](#).....92
- [Marker positioning functions](#)..... 96

### 6.4.1 Marker settings

**Access:** [MKR]

The remote commands required to define these settings are described in [Chapter 9.6.3, "Working with markers"](#), on page 175.

- [Individual marker setup](#).....93
- [General marker settings](#).....95

### 6.4.1.1 Individual marker setup

**Access:** [MKR] > "Marker Config"

In the R&S FSV3 Bluetooth measurement application, up to 17 markers or delta markers can be activated for each window simultaneously.

Marker								
Markers		Marker Settings						
	Selected	State	X-Value	Type	Ref Marker	Link to Marker	Trace	
1-5	Marker 1	On Off	2.409 55 GHz	Norm Delta	1	OFF	1	
6-11	Delta 1	On Off	0 Hz	Norm Delta	1	OFF	1	
	Delta 2	On Off	0 Hz	Norm Delta	1	OFF	1	
12-16	Delta 3	On Off	0 Hz	Norm Delta	1	OFF	1	
	Delta 4	On Off	0 Hz	Norm Delta	1	OFF	1	
	Delta 5	On Off	0 Hz	Norm Delta	1	OFF	1	
All Markers Off								
Specifics for 1: Spectral Display								

The markers are distributed among 3 tabs for a better overview. By default, the first marker is defined as a normal marker, whereas all others are defined as delta markers with reference to the first marker. All markers are assigned to trace 1, but only the first marker is active.

Selected Marker.....	93
Marker State.....	94
Marker Position X-value.....	94
Marker Type.....	94
Reference Marker.....	94
Linking to Another Marker.....	94
Assigning the Marker to a Trace.....	95
All Markers Off.....	95

#### Selected Marker

Marker name. The marker which is currently selected for editing is highlighted orange.

Remote command:

Marker selected via suffix <m> in remote commands.

**Marker State**

Activates or deactivates the marker in the diagram.

Remote command:

[CALCulate<n>:MARKer<m>\[:STATe\]](#) on page 177

[CALCulate<n>:DELTAmarker<m>\[:STATe\]](#) on page 181

**Marker Position X-value**

Defines the position (x-value) of the marker in the diagram. For normal markers, the absolute position is indicated. For delta markers, the position relative to the reference marker is provided.

Remote command:

[CALCulate<n>:MARKer<m>:X](#) on page 178

[CALCulate<n>:DELTAmarker<m>:X](#) on page 180

**Marker Type**

Toggles the marker type.

The type for marker 1 is always "Normal", the type for delta marker 1 is always "Delta". These types cannot be changed.

**Note:** If normal marker 1 is the active marker, switching the "Mkr Type" activates an additional delta marker 1. For any other marker, switching the marker type does not activate an additional marker, it only switches the type of the selected marker.

"Normal"            A normal marker indicates the absolute value at the defined position in the diagram.

"Delta"            A delta marker defines the value of the marker relative to the specified reference marker (marker 1 by default).

Remote command:

[CALCulate<n>:MARKer<m>\[:STATe\]](#) on page 177

[CALCulate<n>:DELTAmarker<m>\[:STATe\]](#) on page 181

**Reference Marker**

Defines a marker as the reference marker which is used to determine relative analysis results (delta marker values).

Remote command:

[CALCulate<n>:DELTAmarker<m>:MREference](#) on page 180

**Linking to Another Marker**

Links the current marker to the marker selected from the list of active markers. If the x-axis value of the initial marker is changed, the linked marker follows to the same position on the x-axis. Linking is off by default.

Using this function you can set two markers on different traces to measure the difference (e.g. between a max hold trace and a min hold trace or between a measurement and a reference trace).

Remote command:

[CALCulate<n>:MARKer<ms>:LINK:TO:MARKer<md>](#) on page 177

[CALCulate<n>:DELTAmarker<ms>:LINK:TO:MARKer<md>](#) on page 179

[CALCulate<n>:DELTAmarker<m>:LINK](#) on page 179

**Assigning the Marker to a Trace**

The "Trace" setting assigns the selected marker to an active trace. The trace determines which value the marker shows at the marker position. If the marker was previously assigned to a different trace, the marker remains on the previous frequency or time, but indicates the value of the new trace.

If a trace is turned off, the assigned markers and marker functions are also deactivated.

Remote command:

`CALCulate<n>:MARKer<m>:TRACe` on page 177

**All Markers Off**

Deactivates all markers in one step.

Remote command:

`CALCulate<n>:MARKer<m>:AOFF` on page 176

**6.4.1.2 General marker settings****Access:**

[MKR] > "Marker Config" > "Marker Settings" tab

Some general marker settings allow you to influence the marker behavior for all markers.

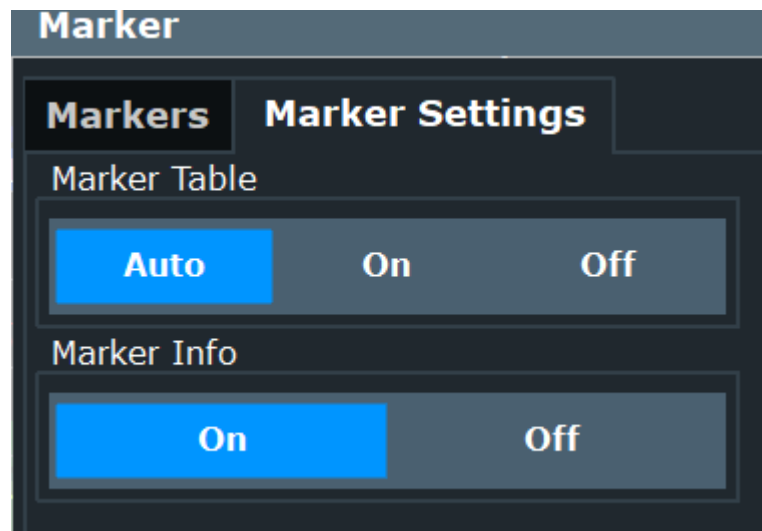

[Marker Table Display](#).....95

[Marker Info](#)..... 96

**Marker Table Display**

Defines how the marker information is displayed.

"On"                    Displays the marker information in a table in a separate area beneath the diagram.

"Off"                    No separate marker table is displayed.

Remote command:

`DISPlay[:WINDow<n>]:MTABLE` on page 182

### Marker Info

Turns the marker information displayed in the diagram on and off.

1AP Clrw	
M1[1]	81.13 dB $\mu$ V 177.610 MHz
D2[1]	-22.18 dB -28.980 MHz

Remote command:

`DISPlay[:WINDow<n>]:MINFo[:STATE]` on page 181

## 6.4.2 Marker positioning functions

The following functions set the currently selected marker to the result of a peak search or set other characteristic values to the current marker value.

Select Marker.....	96
Peak Search.....	97
Search Next Peak.....	97
Search Minimum.....	97
Search Next Minimum.....	97

### Select Marker

The "Select Marker" function opens a dialog box to select and activate or deactivate one or more markers quickly.

Selected	State	Selected	State	Selected	State
Marker 1	On Off	Delta 6	On Off	Delta 12	On Off
Delta 1	On Off	Delta 7	On Off	Delta 13	On Off
Delta 2	On Off	Delta 8	On Off	Delta 14	On Off
Delta 3	On Off	Delta 9	On Off	Delta 15	On Off
Delta 4	On Off	Delta 10	On Off	Delta 16	On Off
Delta 5	On Off	Delta 11	On Off		



Remote command:

[CALCulate<n>:MARKer<m>\[:STATe\]](#) on page 177

[CALCulate<n>:DELTamarker<m>\[:STATe\]](#) on page 181

### Peak Search

Sets the selected marker/delta marker to the maximum of the trace. If no marker is active, marker 1 is activated.

Remote command:

[CALCulate<n>:MARKer<m>:MAXimum\[:PEAK\]](#) on page 185

[CALCulate<n>:DELTamarker<m>:MAXimum\[:PEAK\]](#) on page 183

### Search Next Peak

Sets the selected marker/delta marker to the next (lower) maximum of the assigned trace. If no marker is active, marker 1 is activated.

Remote command:

[CALCulate<n>:MARKer<m>:MAXimum:NEXT](#) on page 185

[CALCulate<n>:MARKer<m>:MAXimum:RIGHT](#) on page 185

[CALCulate<n>:MARKer<m>:MAXimum:LEFT](#) on page 185

[CALCulate<n>:DELTamarker<m>:MAXimum:NEXT](#) on page 183

[CALCulate<n>:DELTamarker<m>:MAXimum:RIGHT](#) on page 183

[CALCulate<n>:DELTamarker<m>:MAXimum:LEFT](#) on page 183

### Search Minimum

Sets the selected marker/delta marker to the minimum of the trace. If no marker is active, marker 1 is activated.

Remote command:

[CALCulate<n>:MARKer<m>:MINimum\[:PEAK\]](#) on page 186

[CALCulate<n>:DELTamarker<m>:MINimum\[:PEAK\]](#) on page 184

### Search Next Minimum

Sets the selected marker/delta marker to the next (higher) minimum of the selected trace. If no marker is active, marker 1 is activated.

Remote command:

[CALCulate<n>:MARKer<m>:MINimum:NEXT](#) on page 186

[CALCulate<n>:MARKer<m>:MINimum:LEFT](#) on page 186

[CALCulate<n>:MARKer<m>:MINimum:RIGHT](#) on page 186

[CALCulate<n>:DELTamarker<m>:MINimum:NEXT](#) on page 184

[CALCulate<n>:DELTamarker<m>:MINimum:LEFT](#) on page 184

[CALCulate<n>:DELTamarker<m>:MINimum:RIGHT](#) on page 184

## 6.5 Display configuration



**Access:** "Overview" > "Display Config"

The captured signal can be displayed using various evaluation methods. All evaluation methods available for the current application are displayed in the evaluation bar in SmartGrid mode.

For a description of the available evaluation methods, see [Chapter 4, "Measurements and result displays"](#), on page 33.

## 7 How to perform Bluetooth BR/EDR/LE measurements

The following step-by-step instructions demonstrate how to perform a Bluetooth BR/EDR/LE measurement with the R&S FSV/A-K8 option.

### To analyze Bluetooth BR/EDR/LE modulation characteristics

1. Select [MODE] > "Bluetooth" to start a Bluetooth measurement channel.
2. Select "Standard" to select the used Bluetooth standard. For "Low Energy", also select the "PHY" type.
3. Select "Overview" to display the configuration "Overview" for a Bluetooth BR/EDR/LE measurement.
4. Select "Select Measurement" > "Modulation Characteristics".
5. By default, the capture time is set long enough to capture bursts consisting of up to 5 slots. To measure 1-slot or 3-slot bursts, you can decrease the capture time to reduce the required measurement time.  
Select "Data Acquisition" > "Capture Time" to define the signal capture settings.
6. Select "Analysis/Limits".  
If necessary, define an "Antenna Gain" to consider for data acquisition.
7. Select "Limits" > "Limit Check": "On" to enable the limit check for the results.
8. Select the "Display Config" button and select the displays that are of interest to you.  
Arrange them on the display to suit your preferences.
9. Exit the SmartGrid mode.
10. Start a new sweep with the defined settings.  
The determined modulation characteristics are displayed. If any limits are exceeded, the results are indicated in red.
11. Optionally, export the trace data of the measured signal to a file.
  - a) Select [TRACE] > "Trace Export".
  - b) Select "Export Trace to ASCII File".
  - c) Define a file name and storage location and select "OK".

### To analyze Bluetooth BR/EDR/LE in-band spurious emissions

1. Select [MODE] > "Bluetooth" to start a Bluetooth measurement channel.
2. Select "Standard" to select the used Bluetooth standard. For "Low Energy", also select the "PHY" type.
3. Select "Overview" to display the configuration "Overview" for a Bluetooth BR/EDR/LE measurement.

4. Select "Select Measurement" > "ACP / In-band Spurious Emissions".
5. Select "Frequency" to define the measurement settings.
  - a) To measure a Bluetooth signal according to French specifications, select "Geography": "France".  
The default values are adapted accordingly.
  - b) If available for your signal type, select "Load Predefined Settings". See [Chapter A, "Predefined standards and settings"](#), on page 205.
  - c) To restrict the measurement to fewer channels, and thus reduce the required measurement time, define the "Number of Captured Channels"
  - d) By default, the capture time is set long enough to capture bursts consisting of up to 5 slots. To measure 1-slot or 3-slot bursts, you can decrease the "Capture Time" to reduce the required measurement time.
  - e) If necessary, define an "Antenna Gain" to consider for data acquisition.
6. For EDR measurements, define the trigger to be used.
  - a) Select "Trigger".
  - b) Define a trigger and gate as required.
7. Select the "Display Config" button and select the displays that are of interest to you.  
Arrange them on the display to suit your preferences.
8. Exit the SmartGrid mode.
9. Start a new sweep with the defined settings.  
The measured spurious emissions in the band are displayed. If any limits are exceeded, the results are indicated in red.
10. Optionally, export the trace data of the measured signal to a file.
  - a) Select [TRACE] > "Trace Export".
  - b) Select "Export Trace to ASCII File".
  - c) Define a file name and storage location and select "OK".

Measurement example 1: Analyzing modulation accuracy for a basic Bluetooth signal

## 8 Measurement examples

The following examples demonstrate how to analyze typical Bluetooth signals for various scenarios.

### 8.1 Measurement example 1: Analyzing modulation accuracy for a basic Bluetooth signal

The following example demonstrates how to analyze the modulation accuracy for a typical basic rate (BR) Bluetooth signal. Note that the procedures can include steps that reflect the default settings for demonstration purposes.

This measurement example assumes that the following Bluetooth signal is used as input:

- Center frequency: 2.441 GHz
- Payload of test sequence  $\Delta f1$ : 00001111
- Payload of test sequence  $\Delta f2$ : 01010101
- Lower address part: 80

#### To analyze Bluetooth BR/EDR/LE modulation characteristics

1. Select [MODE] > "Bluetooth" to start a Bluetooth measurement channel.
2. Select "Standard" > "Basic rate".
3. Select "Overview" to display the configuration "Overview" for a Bluetooth BR/EDR/LE measurement.
4. Select "Select Measurement" > "Modulation Characteristics".
5. Select "Input / Frontend" > "Frequency".
6. Enter the center frequency 2.441 GHz.
7. Select "Burst / Sync" > "LAP".
8. Enter the lower address part: 80.
9. Select "Limits" > "Limit Check": "On" to enable the limit check for the results.
10. Apply the input signal with the first test sequence  $\Delta f1$ .
11. Select [RUN CONT] to start a continuous measurement.
12. Check the "Result Summary" for the  $\Delta f1$  results.

## Measurement example 1: Analyzing modulation accuracy for a basic Bluetooth signal

4 Result Summary					
Packet Information					
Packet Type	DH5				
Packet Length	2870 sym				
Modulation Characteristics	Current	Max	Min	Average	Limits
Output Power Peak	-0.52 dBm	-0.52 dBm	-0.56 dBm	-0.52 dBm	<= 22.00 dBm
Output Power Avg	-0.54 dBm	-0.54 dBm	-0.59 dBm	-0.54 dBm	(0.00 dBm, 20.00 dBm)
Output Power Rel	0.02 dB	0.03 dB	0.02 dB	0.02 dB	
$\Delta f_1$ (00001111) Max	161.05 kHz	161.25 kHz	160.96 kHz	161.09 kHz	
$\Delta f_1$ (00001111) Min	157.71 kHz	157.95 kHz	157.65 kHz	157.83 kHz	
$\Delta f_1$ (00001111) Avg	159.50 kHz	159.51 kHz	159.47 kHz	159.49 kHz	(140.00 kHz, 175.00 kHz)
$\Delta f_2$ (01010101) Max	---	---	---	---	115.00 kHz
$\Delta f_2$ (01010101) Min	---	---	---	---	
$\Delta f_2$ (01010101) Avg	---	---	---	---	
$\Delta f_2$ (max) in range	---	---	---	---	99.90 %
$\Delta f_2 / \Delta f_1$	---	---	---	---	0.80
Freq Drift	---	---	---	---	(-40.00 kHz, 40.00 kHz)
Max Drift Rate / 50 $\mu$ s	---	---	---	---	(-20.00 kHz, 20.00 kHz)
ICFT	-411.57 Hz	-197.30 Hz	-516.67 Hz	-343.00 Hz	(-75.00 kHz, 75.00 kHz)

Any limit failures are indicated in red. In this example, the average output power is too low.

- Increase the power level of the input signal.

4 Result Summary					
Packet Information					
Packet Type	DH5				
Packet Length	2870 sym				
Modulation Characteristics	Current	Max	Min	Average	Limits
Output Power Peak	0.46 dBm	0.46 dBm	-0.56 dBm	-0.34 dBm	<= 22.00 dBm
Output Power Avg	0.44 dBm	0.44 dBm	-0.59 dBm	-0.36 dBm	(0.00 dBm, 20.00 dBm)
Output Power Rel	0.02 dB	0.09 dB	0.02 dB	0.02 dB	
$\Delta f_1$ (00001111) Max	161.11 kHz	161.34 kHz	160.96 kHz	161.12 kHz	
$\Delta f_1$ (00001111) Min	157.89 kHz	157.98 kHz	157.58 kHz	157.84 kHz	
$\Delta f_1$ (00001111) Avg	159.51 kHz	159.54 kHz	159.47 kHz	159.51 kHz	(140.00 kHz, 175.00 kHz)
$\Delta f_2$ (01010101) Max	---	---	---	---	115.00 kHz
$\Delta f_2$ (01010101) Min	---	---	---	---	
$\Delta f_2$ (01010101) Avg	---	---	---	---	
$\Delta f_2$ (max) in range	---	---	---	---	99.90 %
$\Delta f_2 / \Delta f_1$	---	---	---	---	0.80
Freq Drift	---	---	---	---	(-40.00 kHz, 40.00 kHz)
Max Drift Rate / 50 $\mu$ s	---	---	---	---	(-20.00 kHz, 20.00 kHz)
ICFT	-335.78 Hz	-197.30 Hz	-516.67 Hz	-347.02 Hz	(-75.00 kHz, 75.00 kHz)

The current output power values turn green because the lower limit is no longer exceeded, but the minimum value still reflects the failure of the previously lower output.

- Select "Display Config" and drag the "Symbols" display into the SmartGrid. Arrange the windows on the display to suit your preferences.
- Exit the SmartGrid mode.
- Compare the demodulated payload symbols in the display (white) with the test sequence  $\Delta f_1$  (00001111).

Measurement example 1: Analyzing modulation accuracy for a basic Bluetooth signal

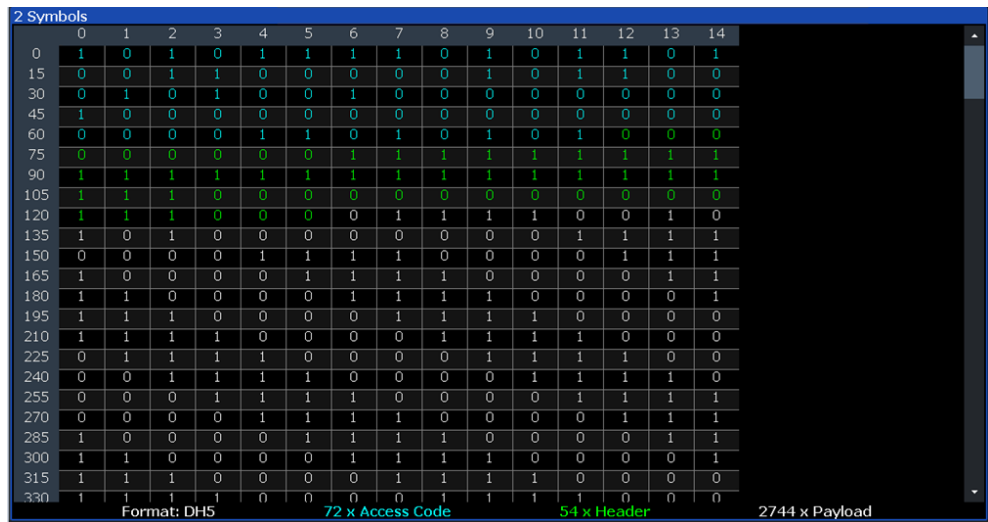

The package type is correctly identified as "DH5".

- 17. Apply the input signal with the second test sequence  $\Delta f_2$ .
- 18. Check the "Result Summary" for the  $\Delta f_2$  and combined  $\Delta f_1 / \Delta f_2$  results.

4 Result Summary					
Packet Information					
Packet Type	DH5				
Packet Length	2870 sym				
Modulation Characteristics					
	Current	Max	Min	Average	Limits
Output Power Peak	0.46 dBm	0.50 dBm	-0.56 dBm	0.16 dBm	<= 22.00 dBm
Output Power Avg	0.43 dBm	0.48 dBm	-0.59 dBm	0.14 dBm	(0.00 dBm, 20.00 dBm)
Output Power Rel	0.03 dB	0.09 dB	0.02 dB	0.02 dB	
$\Delta f_1$ (00001111) Max	---	161.36 kHz	160.93 kHz	161.10 kHz	
$\Delta f_1$ (00001111) Min	---	157.98 kHz	157.58 kHz	157.83 kHz	
$\Delta f_1$ (00001111) Avg	---	159.54 kHz	159.47 kHz	159.50 kHz	(140.00 kHz, 175.00 kHz)
$\Delta f_2$ (01010101) Max	148.81 kHz	149.19 kHz	148.07 kHz	148.64 kHz	
$\Delta f_2$ (01010101) Min	140.29 kHz	140.50 kHz	139.63 kHz	140.07 kHz	115.00 kHz
$\Delta f_2$ (01010101) Avg	146.84 kHz	146.85 kHz	146.80 kHz	146.83 kHz	
$\Delta f_2$ (max) in range	100.00 %	100.00 %	100.00 %	100.00 %	99.90 %
$\Delta f_2 / \Delta f_1$	0.92	---	---	---	0.80
Freq Drift	448.53 Hz	626.69 Hz	394.97 Hz	495.39 Hz	(-40.00 kHz, 40.00 kHz)
Max Drift Rate / 50us	163.00 Hz	200.44 Hz	-99.52 Hz	1.08 Hz	(-20.00 kHz, 20.00 kHz)
ICFT	-302.59 Hz	-186.24 Hz	-516.67 Hz	-342.63 Hz	(-75.00 kHz, 75.00 kHz)

- 19. Check the "Symbols" display.

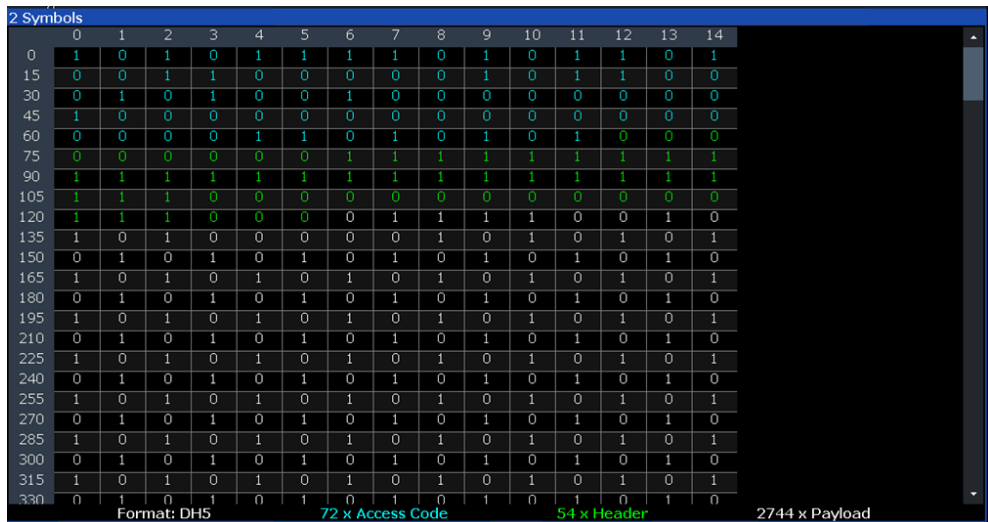

## Measurement example 2: Analyzing in-band spurious emissions for a basic Bluetooth signal

The payload symbols (white) now show the second test sequence  $\Delta f_2$  (01010101).

20. Optionally, export the trace data of the measured signals to a file.
  - a) Select [TRACE] > "Trace Export".
  - b) Select "Export Trace to ASCII File".
  - c) Define a file name and storage location and select "OK".

## 8.2 Measurement example 2: Analyzing in-band spurious emissions for a basic Bluetooth signal

The following example demonstrates how to analyze the channel power for a typical Bluetooth basic rate signal, outside of France. Note that the procedures can include steps that reflect the default settings for demonstration purposes.

This measurement example uses the predefined settings file  
`C:\R_S\INSTR\USER\predefined\BTOPredefined\Bluetooth_DH1DH3DH5.xml.`

It assumes that the following Bluetooth signal is used as input:

- Center frequency: 2.441 GHz
  - Sample rate: 102.4 MHz
  - Duration of signal: 100 ms
  - Number of channels: 79
  - Antenna gain: 0.0 dB
1. Press [MODE] on the front panel and select the "Bluetooth" operating mode.
  2. Select "Standard" > "Basic Rate".
  3. Select "Overview" to display the configuration "Overview" for a Bluetooth BR/EDR/LE measurement.
  4. Select "Select Measurement" > "ACP / In-band Spur Emissions".
  5. Select "Frequency" to define the measurement settings.
    - a) Select "Load Predefined Settings".
    - b) Select the settings file  
`C:\R_S\INSTR\USER\predefined\BTOPredefined\Bluetooth_DH1DH3DH5.xml.`
  6. Select "TX Channel": "Mid" to select the middle channel as the transmit channel.
  7. Select [RUN SINGLE] to start a new sweep with the defined settings.
  8. Check the result of the "Limit Check" in the "ACP / In-band Spurious Emissions" display.
  9. If the limit check failed, check the channel power details in the "Result Summary" to determine which channel exceeded the limit.



## Measurement example 2: Analyzing in-band spurious emissions for a basic Bluetooth signal

10. Select the next channel as the transmit channel and repeat the measurement.
  - a) Select "TX Channel No".
  - b) Use the rotary knob or the arrow keys to move through the channels.
  - c) Select [RUN SINGLE].
  
11. Optionally, export the trace data of the measured signal to a file.
  - a) Select [TRACE] > "Trace Export".
  - b) Select "Export Trace to ASCII File".
  - c) Define a file name and storage location and select "OK".

## 9 Remote commands to perform Bluetooth BR/EDR/LE measurements

The commands required to perform measurements in the R&S FSV3 Bluetooth measurement application in a remote environment are described here.

It is assumed that the R&S FSV/A has already been set up for remote control in a network as described in the R&S FSV/A User Manual.



A programming example at the end of the remote commands description demonstrates the most important commands in a typical application scenario, see [Chapter 9.10, "Programming examples: Measuring Bluetooth BR/EDR/LE signals"](#), on page 202.



Note that basic tasks that are also performed in the base unit in the same way are not described here. For a description of such tasks, see the R&S FSV/A User Manual.

In particular:

- Basic instrument configuration, e.g. checking the system configuration, customizing the screen layout, or configuring networks and remote operation
- Using the common status registers



### Status registers

The R&S FSV3-K7 option uses the status registers of the base unit (except for the `STATus:QUESTionable:ACPLimit` register).

For a description, see the R&S FSV/A User Manual.

### General R&S FSV/A Remote Commands

The application-independent remote commands for general tasks on the R&S FSV/A are also available for Bluetooth BR/EDR/LE measurements and are described in the R&S FSV/A User Manual. In particular:

- Managing settings and results
- Setting up the instrument
- Using the status register



### SCPI Recorder - automating tasks with remote command scripts

The R&S FSV3 Bluetooth measurement application also supports the SCPI Recorder functionality.

Using the SCPI Recorder functions, you can create a SCPI script directly on the instrument and then export the script for use on the controller. You can also edit or write a script manually, using a suitable editor on the controller. For manual creation, the instrument supports you by showing the corresponding command syntax for the current setting value.

For details see the "Network and Remote Operation" chapter in the R&S FSV/A User Manual.

- [Introduction](#)..... 107
- [Common suffixes](#)..... 112
- [Activating Bluetooth BR/EDR/LE Measurements](#)..... 112
- [Configuring Bluetooth BR/EDR/LE measurements](#)..... 116
- [Performing a measurement](#)..... 148
- [Analyzing Bluetooth BR/EDR/LE measurements](#)..... 152
- [Configuring the result display](#)..... 187
- [Retrieving results](#)..... 195
- [Deprecated commands](#)..... 199
- [Programming examples: Measuring Bluetooth BR/EDR/LE signals](#)..... 202

## 9.1 Introduction

Commands are program messages that a controller (e.g. a PC) sends to the instrument or software. They operate its functions ('setting commands' or 'events') and request information ('query commands'). Some commands can only be used in one way, others work in two ways (setting and query). If not indicated otherwise, the commands can be used for settings and queries.

The syntax of a SCPI command consists of a header and, usually, one or more parameters. To use a command as a query, you have to append a question mark after the last header element, even if the command contains a parameter.

A header contains one or more keywords, separated by a colon. Header and parameters are separated by a "white space" (ASCII code 0 to 9, 11 to 32 decimal, e.g. blank). If there is more than one parameter for a command, they are separated by a comma from one another.

Only the most important characteristics that you need to know when working with SCPI commands are described here. For a more complete description, refer to the user manual of the R&S FSV/A.



### Remote command examples

Note that some remote command examples mentioned in this general introduction are possibly not supported by this particular application.

### 9.1.1 Conventions used in descriptions

The following conventions are used in the remote command descriptions:

- **Command usage**  
If not specified otherwise, commands can be used both for setting and for querying parameters.  
If a command can be used for setting or querying only, or if it initiates an event, the usage is stated explicitly.
- **Parameter usage**  
If not specified otherwise, a parameter can be used to set a value, and it is the result of a query.  
Parameters required only for setting are indicated as **Setting parameters**.  
Parameters required only to refine a query are indicated as **Query parameters**.  
Parameters that are only returned as the result of a query are indicated as **Return values**.
- **Conformity**  
Commands that are taken from the SCPI standard are indicated as **SCPI confirmed**. All commands used by the R&S FSV/A follow the SCPI syntax rules.
- **Asynchronous commands**  
A command which does not automatically finish executing before the next command starts executing (overlapping command) is indicated as an **Asynchronous command**.
- **Reset values (\*RST)**  
Default parameter values that are used directly after resetting the instrument (\*RST command) are indicated as **\*RST** values, if available.
- **Default unit**  
The default unit is used for numeric values if no other unit is provided with the parameter.
- **Manual operation**  
If the result of a remote command can also be achieved in manual operation, a link to the description is inserted.

### 9.1.2 Long and short form

The keywords have a long and a short form. You can use either the long or the short form, but no other abbreviations of the keywords.

The short form is emphasized in uppercase letters. Note however, that this emphasis only serves the purpose to distinguish the short from the long form in the manual. For the instrument, the case does not matter.

**Example:**

SENSe:FREQuency:CENTer is the same as SENS:FREQ:CENT.

### 9.1.3 Numeric suffixes

Some keywords have a numeric suffix if the command can be applied to multiple instances of an object. In that case, the suffix selects a particular instance (e.g. a measurement window).

Numeric suffixes are indicated by angular brackets (<n>) next to the keyword.

If you do not quote a suffix for keywords that support one, a 1 is assumed.

**Example:**

`DISPlay[:WINDow<1...4>]:ZOOM:STATe` enables the zoom in a particular measurement window, selected by the suffix at `WINDow`.

`DISPlay:WINDow4:ZOOM:STATe ON` refers to window 4.

### 9.1.4 Optional keywords

Some keywords are optional and are only part of the syntax because of SCPI compliance. You can include them in the header or not.



If an optional keyword has a numeric suffix and you need to use the suffix, you have to include the optional keyword. Otherwise, the suffix of the missing keyword is assumed to be the value 1.

Optional keywords are emphasized with square brackets.

**Example:**

Without a numeric suffix in the optional keyword:

`[SENSe:]FREQuency:CENTer` is the same as `FREQuency:CENTer`

With a numeric suffix in the optional keyword:

`DISPlay[:WINDow<1...4>]:ZOOM:STATe`

`DISPlay:ZOOM:STATe ON` enables the zoom in window 1 (no suffix).

`DISPlay:WINDow4:ZOOM:STATe ON` enables the zoom in window 4.

### 9.1.5 Alternative keywords

A vertical stroke indicates alternatives for a specific keyword. You can use both keywords to the same effect.

**Example:**

`[SENSe:]BANDwidth|BWIDth[:RESolution]`

In the short form without optional keywords, `BAND 1MHZ` would have the same effect as `BWID 1MHZ`.

## 9.1.6 SCPI parameters

Many commands feature one or more parameters.

If a command supports more than one parameter, they are separated by a comma.

### Example:

```
LAYout:ADD:WINDow Spectrum,LEFT,MTABLE
```

Parameters can have different forms of values.

- [Numeric values](#)..... 110
- [Boolean](#)..... 111
- [Character data](#)..... 111
- [Character strings](#)..... 111
- [Block data](#)..... 112

### 9.1.6.1 Numeric values

Numeric values can be entered in any form, i.e. with sign, decimal point or exponent. For physical quantities, you can also add the unit. If the unit is missing, the command uses the basic unit.

### Example:

With unit: `SENSe:FREQuency:CENTer 1GHZ`

Without unit: `SENSe:FREQuency:CENTer 1E9` would also set a frequency of 1 GHz.

Values exceeding the resolution of the instrument are rounded up or down.

If the number you have entered is not supported (e.g. for discrete steps), the command returns an error.

Instead of a number, you can also set numeric values with a text parameter in special cases.

- **MIN/MAX**  
Defines the minimum or maximum numeric value that is supported.
- **DEF**  
Defines the default value.
- **UP/DOWN**  
Increases or decreases the numeric value by one step. The step size depends on the setting. Sometimes, you can customize the step size with a corresponding command.

### Querying numeric values

When you query numeric values, the system returns a number. For physical quantities, it applies the basic unit (e.g. Hz for frequencies). The number of digits after the decimal point depends on the type of numeric value.

**Example:**

Setting: `SENSe:FREQuency:CENTer 1GHZ`

Query: `SENSe:FREQuency:CENTer?` would return `1E9`

Sometimes, numeric values are returned as text.

- **INF/NINF**  
Infinity or negative infinity. Represents the numeric values `9.9E37` or `-9.9E37`.
- **NAN**  
Not a number. Represents the numeric value `9.91E37`. NAN is returned if errors occur.

### 9.1.6.2 Boolean

Boolean parameters represent two states. The "on" state (logically true) is represented by "ON" or the numeric value 1. The "off" state (logically untrue) is represented by "OFF" or the numeric value 0.

**Querying Boolean parameters**

When you query Boolean parameters, the system returns either the value 1 ("ON") or the value 0 ("OFF").

**Example:**

Setting: `DISPlay:WINDow:ZOOM:STATe ON`

Query: `DISPlay:WINDow:ZOOM:STATe?` would return `1`

### 9.1.6.3 Character data

Character data follows the syntactic rules of keywords. You can enter text using a short or a long form. For more information, see [Chapter 9.1.2, "Long and short form"](#), on page 108.

**Querying text parameters**

When you query text parameters, the system returns its short form.

**Example:**

Setting: `SENSe:BANDwidth:RESolution:TYPE NORMAl`

Query: `SENSe:BANDwidth:RESolution:TYPE?` would return `NORM`

### 9.1.6.4 Character strings

Strings are alphanumeric characters. They have to be in straight quotation marks. You can use a single quotation mark ( ' ) or a double quotation mark ( " ).

**Example:**

```
INSTRument:DELeTe 'Spectrum'
```

**9.1.6.5 Block data**

Block data is a format which is suitable for the transmission of large amounts of data.

The ASCII character # introduces the data block. The next number indicates how many of the following digits describe the length of the data block. The data bytes follow. During the transmission of these data bytes, all end or other control signs are ignored until all bytes are transmitted. #0 specifies a data block of indefinite length. The use of the indefinite format requires an NL^END message to terminate the data block. This format is useful when the length of the transmission is not known or if speed or other considerations prevent segmentation of the data into blocks of definite length.

**9.2 Common suffixes**

In the R&S FSV3 Bluetooth measurement application, the following common suffixes are used in remote commands:

*Table 9-1: Common suffixes used in remote commands in the R&S FSV3 Bluetooth measurement application*

Suffix	Value range	Description
<m>	1 to 16	Marker
<n>	1 to 6	Window (in the currently selected channel)
<t>	1 to 4	Trace
<li>	1 to 8	Limit line

**9.3 Activating Bluetooth BR/EDR/LE Measurements**

Bluetooth BR/EDR/LE measurements requires a special application on the R&S FSV/A. A measurement is started immediately with the default settings.

INSTRument:CREate:DUPLicate.....	113
INSTRument:CREate[:NEW].....	113
INSTRument:CREate:REPLace.....	113
INSTRument:DELeTe.....	114
INSTRument:LIST?.....	114
INSTRument:REName.....	115
INSTRument[:SElect].....	115
SYSTem:PRESet:CHANnel[:EXEC].....	116



**INSTrument:CREate:DUPLicate**

Duplicates the currently selected channel, i.e creates a new channel of the same type and with the identical measurement settings. The name of the new channel is the same as the copied channel, extended by a consecutive number (e.g. "IQAnalyzer" -> "IQAnalyzer 2").

The channel to be duplicated must be selected first using the `INST:SEL` command.

**Example:** `INST:SEL 'IQAnalyzer'`  
`INST:CRE:DUPL`  
 Duplicates the channel named 'IQAnalyzer' and creates a new channel named 'IQAnalyzer2'.

**Usage:** Event

**INSTrument:CREate[:NEW] <ChannelType>, <ChannelName>**

Adds a measurement channel. You can configure up to 10 measurement channels at the same time (depending on available memory).

**Parameters:**

<ChannelType> Channel type of the new channel.  
 For a list of available channel types, see [INSTrument:LIST?](#) on page 114.

<ChannelName> String containing the name of the channel.  
 Note that you cannot assign an existing channel name to a new channel. If you do, an error occurs.

**Example:** `INST:CRE SAN, 'Spectrum 2'`  
 Adds a spectrum display named "Spectrum 2".

**INSTrument:CREate:REPLace <ChannelName1>, <ChannelType>, <ChannelName2>**

Replaces a channel with another one.

**Setting parameters:**

<ChannelName1> String containing the name of the channel you want to replace.

<ChannelType> Channel type of the new channel.  
 For a list of available channel types, see [INSTrument:LIST?](#) on page 114.

<ChannelName2> String containing the name of the new channel.  
**Note:** If the specified name for a new channel already exists, the default name, extended by a sequential number, is used for the new channel (see [INSTrument:LIST?](#) on page 114).  
 Channel names can have a maximum of 31 characters, and must be compatible with the Windows conventions for file names. In particular, they must not contain special characters such as ":", "\*", "?".

**Example:** `INST:CRE:REPL 'IQAnalyzer2', IQ, 'IQAnalyzer'`  
Replaces the channel named "IQAnalyzer2" by a new channel of type "IQ Analyzer" named "IQAnalyzer".

**Usage:** Setting only

### **INSTrument:DELeTe** <ChannelName>

Deletes a channel.

#### **Setting parameters:**

<ChannelName> String containing the name of the channel you want to delete.  
A channel must exist to delete it.

**Usage:** Setting only

### **INSTrument:LIST?**

Queries all active channels. The query is useful to obtain the names of the existing channels, which are required to replace or delete the channels.

#### **Return values:**

<ChannelType>, <ChannelName> For each channel, the command returns the channel type and channel name (see tables below).  
Tip: to change the channel name, use the [INSTrument:REName](#) command.

**Example:** `INST:LIST?`  
Result for 3 channels:  
'ADEM', 'Analog Demod', 'IQ', 'IQ Analyzer', 'IQ', 'IQ Analyzer2'

**Usage:** Query only

**Table 9-2: Available channel types and default channel names**

Application	<ChannelType> Parameter	Default Channel Name*)
Spectrum	SANALYZER	Spectrum
5G NR (R&S FSV3-K144)	NR5G	5G NR
3GPP FDD BTS (R&S FSV3-K72)	BWCD	3G FDD BTS
3GPP FDD UE (R&S FSV3-K73)	MWCD	3G FDD UE
Amplifier Measurements (R&S FSV3-K18)	AMPLifier	Amplifier
AM/FM/PM Modulation Analysis	ADEM	Analog Demod
Bluetooth (R&S FSV3-K8)	BTO	Bluetooth

Note: the default channel name is also listed in the table. If the specified name for a new channel already exists, the default name, extended by a sequential number, is used for the new channel.

Application	<ChannelType> Parameter	Default Channel Name*)
GSM (R&S FSV3-K10)	GSM	GSM
I/Q Analyzer	IQ	IQ Analyzer
LTE (R&S FSV3-K10x)	LTE	LTE
NB-IoT (R&S FSV3-K106)	NIOT	NB-IoT
Noise Figure Measurements	NOISE	Noise
OFDM VSA (R&S FSV3-K96)	OFDMVSA	OFDM VSA
Phase Noise (R&S FSV3-K40)	PNOISE	Phase Noise
Pulse (R&S FSV3-K6)	PULSE	Pulse
Vector Signal Analysis (VSA, R&S FSV3-K70)	DDEM	VSA
WLAN (R&S FSV3-K91)	WLAN	WLAN

Note: the default channel name is also listed in the table. If the specified name for a new channel already exists, the default name, extended by a sequential number, is used for the new channel.

---

**INSTrument:REName** <ChannelName1>, <ChannelName2>

Renames a channel.

**Setting parameters:**

<ChannelName1> String containing the name of the channel you want to rename.

<ChannelName2> String containing the new channel name.  
 Note that you cannot assign an existing channel name to a new channel. If you do, an error occurs.  
 Channel names can have a maximum of 31 characters, and must be compatible with the Windows conventions for file names. In particular, they must not contain special characters such as ":", "\*", "?".

**Example:** `INST:REN 'IQAnalyzer2', 'IQAnalyzer3'`  
 Renames the channel with the name 'IQAnalyzer2' to 'IQAnalyzer3'.

**Usage:** Setting only

---

**INSTrument[:SElect]** <ChannelType>

Selects the application (channel type) for the current channel.

See also `INSTrument:CREate[:NEW]` on page 113.

For a list of available channel types see `INSTrument:LIST?` on page 114.

**Parameters:**

<ChannelType>      **Bluetooth**  
Bluetooth, R&S FSV3-K8

**SYSTem:PRESet:CHANnel[:EXEC]**

Restores the default instrument settings in the current channel.

Use `INST:SEL` to select the channel.

**Example:**

```
INST:SEL 'Spectrum2'
```

Selects the channel for "Spectrum2".

```
SYST:PRESet:CHAN:EXEC
```

Restores the factory default settings to the "Spectrum2" channel.

**Usage:**                    Event

**Manual operation:**    See "[Preset Channel](#)" on page 46

## 9.4 Configuring Bluetooth BR/EDR/LE measurements

- [Selecting the standard and measurement](#)..... 116
- [Input and output settings](#)..... 118
- [Amplitude settings](#)..... 125
- [Frequency settings](#)..... 130
- [Triggering measurements](#)..... 132
- [Gating](#)..... 136
- [Adjusting settings automatically](#)..... 141
- [Configuring Modulation Characteristics measurements](#)..... 143
- [Configuring In-band Spurious Emissions measurements](#)..... 147

### 9.4.1 Selecting the standard and measurement

<a href="#">CONFigure:BT0oth[:STANdard]</a> .....	116
<a href="#">CONFigure:BT0oth:LEnergy</a> .....	117
<a href="#">CONFigure:BT0oth:MEASurement</a> .....	117

**CONFigure:BT0oth[:STANdard]** <Standard>

Defines the Bluetooth standard the signal complies with.

For details on the different standards, see [Chapter 3, "Measurement basics"](#), on page 12.

**Parameters:**

<Standard>                BR | EDR | LE  
**BR**  
Basic rate

**EDR**

Enhanced data rate

**LE**

Low energy

Requires a substandard, see [CONFigure:BT0oth:LEnergy](#) on page 117

\*RST: BR

**Example:**

```
CONF:BT0 LE
CONF:BT0:LEN LE2M
```

**Manual operation:** See "[Standard](#)" on page 47**CONFigure:BT0oth:LEnergy <LE1M>**

For measurements based on the **low-energy** standard ([CONFigure:BT0oth\[:STANdard\]LE](#)), this command defines the substandard depending on the used physical layer (PHY).

**Parameters:**

&lt;LE1M&gt; LE1M | LE2M | LECoded

**LE1M**

uncoded, 1 symbol per data bit, 1 Msymbol/s data rate

**LE2M**

uncoded, 1 symbol per data bit, 2 Msymbol/s data rate

**LECoded**

2 symbols per data bit, 1 Msymbol/s data rate

\*RST: LE1M

**Example:**

```
CONF:BT0 LE
CONF:BT0:LEN LE2M
```

**Manual operation:** See "[Standard](#)" on page 47**CONFigure:BT0oth:MEASurement <MeasType>**

Selects a measurement to be performed.

See [Chapter 4, "Measurements and result displays"](#), on page 33.**Parameters:**

&lt;MeasType&gt; MCH | MOD | SEM

**MOD**

Modulation characteristics

**SEM**

In-band spurious emissions

\*RST: MOD

**Example:**

```
CONF:BT0 SEM
```

**Manual operation:** See "[Select Measurement](#)" on page 46

## 9.4.2 Input and output settings

The R&S FSV/A can analyze signals from different input sources.

Manual configuration of the input and output is described in [Chapter 5.3, "Input, output and frontend settings"](#), on page 47 and [Chapter 5.3.3, "Output settings"](#), on page 51.

- [RF input](#)..... 118
- [Configuring file input](#)..... 121
- [Output settings](#)..... 122
- [Configuring the trigger output](#)..... 123

### 9.4.2.1 RF input

<a href="#">INPut:ATTenuation:PROTection:RESet</a> .....	118
<a href="#">INPut:COUPling</a> .....	118
<a href="#">INPut:DPATH</a> .....	119
<a href="#">INPut:FILTer:HPASs[:STATe]</a> .....	119
<a href="#">INPut:FILTer:YIG[:STATe]</a> .....	119
<a href="#">INPut:IMPedance</a> .....	120
<a href="#">INPut:IMPedance:PTYPE</a> .....	120
<a href="#">INPut:SElect</a> .....	120
<a href="#">INPut:TYPE</a> .....	120

---

#### **INPut:ATTenuation:PROTection:RESet**

Resets the attenuator and reconnects the RF input with the input mixer for the R&S FSV/A after an overload condition occurred and the protection mechanism intervened. The error status bit (bit 3 in the `STAT:QUES:POW` status register) and the `INPUT OVLD` message in the status bar are cleared.

The command works only if the overload condition has been eliminated first.

**Example:** `INP:ATT:PROT:RES`

---

#### **INPut:COUPling <CouplingType>**

Selects the coupling type of the RF input.

##### **Parameters:**

<CouplingType>	AC   DC
	<b>AC</b>
	AC coupling
	<b>DC</b>
	DC coupling
*RST:	AC

**Example:** `INP:COUP DC`

**Manual operation:** See ["Input Coupling"](#) on page 49

**INPut:DPATH** <DirectPath>

Enables or disables the use of the direct path for frequencies close to 0 Hz.

**Parameters:**

<DirectPath>            AUTO | OFF

**AUTO | 1**  
(Default) the direct path is used automatically for frequencies close to 0 Hz.

**OFF | 0**  
The analog mixer path is always used.

**Example:**            INP:DPAT OFF

**Manual operation:** See "[Direct Path](#)" on page 49

**INPut:FILTer:HPASs[:STATe]** <State>

Activates an additional internal high-pass filter for RF input signals from 1 GHz to 3 GHz. This filter is used to remove the harmonics of the R&S FSV/A to measure the harmonics for a DUT, for example.

Requires an additional high-pass filter hardware option.

(Note: for RF input signals outside the specified range, the high-pass filter has no effect. For signals with a frequency of approximately 4 GHz upwards, the harmonics are suppressed sufficiently by the YIG-preselector, if available.)

**Parameters:**

<State>                ON | OFF | 0 | 1

**OFF | 0**  
Switches the function off

**ON | 1**  
Switches the function on

\*RST:                0

**Example:**            INP:FILT:HPAS ON  
Turns on the filter.

**INPut:FILTer:YIG[:STATe]** <State>

Enables or disables the YIG filter.

**Parameters:**

<State>                ON | OFF | 0 | 1

**Example:**            INP:FILT:YIG OFF  
Deactivates the YIG-preselector.

**Manual operation:** See "[YIG-Preselector](#)" on page 49

**INPut:IMPedance** <Impedance>

Selects the nominal input impedance of the RF input. In some applications, only 50 Ω are supported.

**Parameters:**

<Impedance> 50 | 75  
 \*RST: 50 Ω  
 Default unit: OHM

**Example:** INP:IMP 75

**Manual operation:** See "[Impedance](#)" on page 50  
 See "[Impedance](#)" on page 56

**INPut:IMPedance:PTYPe** <PadType>

Defines the type of matching pad used for impedance conversion for RF input.

**Parameters:**

<PadType> SRESistor | MLPad  
**SRESistor**  
 Series-R  
**MLPad**  
 Minimum Loss Pad  
 \*RST: SRESistor

**Example:** INP:IMP 100  
 INP:IMP:PTYP MLP

**Manual operation:** See "[Impedance](#)" on page 50

**INPut:SELEct** <Source>

Selects the signal source for measurements, i.e. it defines which connector is used to input data to the R&S FSV/A.

**Parameters:**

<Source> **RF**  
 Radio Frequency ("RF INPUT" connector)  
 \*RST: RF

**Manual operation:** See "[Radio Frequency State](#)" on page 49  
 See "[I/Q Input File State](#)" on page 50

**INPut:TYPE** <Input>

The command selects the input path.

**Parameters:**

<Input> **INPUT1**  
 Selects RF input 1.



**INPUT2**

Selects RF input 2.

`*RST: INPUT1`**Example:**

```
//Select input path
INP:TYPE INPUT1
```

**9.4.2.2 Configuring file input**

The following commands are required to define input from a file.

Useful commands for configuring file input described elsewhere:

- `INPut:SElect` on page 120

**Remote commands exclusive to configuring input from files:**

`INPut:FILE:PATH`..... 121

---

**INPut:FILE:PATH** <FileName>[, <AnalysisBW>]

Selects the I/Q data file to be used as input for further measurements.

The I/Q data file must be in one of the following supported formats:

- `.iq.tar`
- `.iqw`
- `.csv`
- `.mat`
- `.wv`
- `.aid`

Only a single data stream or channel can be used as input, even if multiple streams or channels are stored in the file.

For some file formats that do not provide the sample rate and measurement time or record length, you must define these parameters manually. Otherwise the traces are not visible in the result displays.

**Parameters:**

<FileName> String containing the path and name of the source file.  
The file type is determined by the file extension. If no file extension is provided, the file type is assumed to be `.iq.tar`.  
For `.mat` files, Matlab® v4 is assumed.

<AnalysisBW> Optionally: The analysis bandwidth to be used by the measurement. The bandwidth must be smaller than or equal to the bandwidth of the data that was stored in the file.

Default unit: HZ

**Example:**

```
INP:FILE:PATH 'C:\R_S\Instr\user\data.iq.tar'
```

Uses I/Q data from the specified file as input.

**Example:**

```
//Load an IQW file
INP:SEL:FIQ
INP:FILE:PATH 'C:\R_S\Instr\user\data.iqw'
//Define the sample rate
TRAC:IQ:SRAT 10MHz
//Define the measurement time
SENSe:SWEEp:TIME 0.001001
//Start the measurement
INIT:IMM
```

**Manual operation:** See ["Select I/Q data file"](#) on page 51

### 9.4.2.3 Output settings

The following commands are required to query or provide output at the R&S FSV/A connectors.

---

#### DIAGnostic:SERVice:NSOource <State>

Turns the 28 V supply of the BNC connector labeled [noise source control] on the R&S FSV/A on and off.

**Parameters:**

<State>                    ON | OFF | 0 | 1  
**OFF | 0**  
 Switches the function off  
**ON | 1**  
 Switches the function on

**Example:**                DIAG:SERV:NSO ON

**Manual operation:** See ["Noise Source Control"](#) on page 52

---

#### OUTPut:IF:SBAND?

Queries the sideband provided at the "IF OUT 2 GHz" connector compared to the sideband of the RF signal. The sideband depends on the current center frequency.

**Return values:**

<SideBand>                **NORMal**  
 The sideband at the output is identical to the RF signal.  
**INVerted**  
 The sideband at the output is the inverted RF signal sideband.

**Example:**                OUTP:IF IF2  
 Activates output at the IF OUTPUT (2 GHz) connector.  
 OUTP:IF:SBAN?  
 Queries the sideband provided at the connector.

**Usage:**                    Query only

**OUTPut:IF[:SOURce] <Source>**

Defines the type of signal available at one of the output connectors of the R&S FSV/A.

**Parameters:**

<Source>                    **IF**  
 The measured IF value is available at the IF output connector.  
 This connector is only available if the R&S FSV3-B5 option is installed.

\*RST:                    IF

**Example:**

OUTPut:IF VID  
 Selects the video signal for the IF output connector.

**9.4.2.4 Configuring the trigger output**

The following commands are required to send the trigger signal to one of the variable "TRIGGER INPUT/OUTPUT" connectors on the R&S FSV/A.

OUTPut:TRIGger<tp>:DIRection.....	123
OUTPut:TRIGger<tp>:LEVel.....	123
OUTPut:TRIGger<tp>:OTYPe.....	124
OUTPut:TRIGger<tp>:PULSe:IMMediate.....	124
OUTPut:TRIGger<tp>:PULSe:LENGth.....	125

**OUTPut:TRIGger<tp>:DIRection <Direction>**

Selects the trigger direction for trigger ports that serve as an input as well as an output.

**Suffix:**

<tp>

**Parameters:**

<Direction>                    INPut | OUTPut

**INPut**  
 Port works as an input.

**OUTPut**  
 Port works as an output.

\*RST:                    INPut

**OUTPut:TRIGger<tp>:LEVel <Level>**

Defines the level of the (TTL compatible) signal generated at the trigger output.

Works only if you have selected a user-defined output with [OUTPut:TRIGger<tp>:OTYPe](#).

**Suffix:**

<tp> 1..n  
 Selects the trigger port to which the output is sent.  
 2 = trigger port 2 (front)  
 3 = trigger port 3 (rear)  
 2 = Trigger 2 Input / Output

**Parameters:**

<Level> **HIGH**  
 5 V  
**LOW**  
 0 V  
 \*RST: LOW

**Example:** OUTP:TRIG2:LEV HIGH

**OUTPut:TRIGger<tp>:OTYPe <OutputType>**

Selects the type of signal generated at the trigger output.

**Suffix:**

<tp> 1..n  
 Selects the trigger port to which the output is sent.  
 2 = trigger port 2 (front)  
 3 = trigger port 3 (rear)  
 2 = Trigger 2 Input / Output

**Parameters:**

<OutputType> **DEVIce**  
 Sends a trigger signal when the R&S FSV/A has triggered internally.

**TARMed**  
 Sends a trigger signal when the trigger is armed and ready for an external trigger event.

**UDEFI ned**  
 Sends a user-defined trigger signal. For more information, see [OUTPut:TRIGger<tp>:LEVel](#).

\*RST: DEVIce

**OUTPut:TRIGger<tp>:PULSe:IMMediate**

Generates a pulse at the trigger output.

**Suffix:**

<tp> 1..n  
 Selects the trigger port to which the output is sent.  
 2 = trigger port 2 (front)  
 3 = trigger port 3 (rear)  
 2 = Trigger 2 Input / Output

**OUTPut:TRIGger<tp>:PULSe:LENGth <Length>**

Defines the length of the pulse generated at the trigger output.

**Suffix:**

<tp>                      Selects the trigger port to which the output is sent.  
                               2 = trigger port 2 (front)  
                               3 = trigger port 3 (rear)  
                               2 = Trigger 2 Input / Output

**Parameters:**

<Length>                 Pulse length in seconds.  
                               Default unit: S

**Example:**                `OUTP:TRIG2:PULS:LENG 0.02`

### 9.4.3 Amplitude settings

Amplitude and scaling settings allow you to configure the vertical (y-)axis display and for some result displays also the horizontal (x-)axis.

Useful commands for amplitude settings described elsewhere:

- [INPut:COUPling](#) on page 118
- [INPut:IMPedance](#) on page 120
- [\[SENSe:\]ADJust:LEVel](#) on page 143

**Remote commands exclusive to amplitude settings:**

<a href="#">CALCulate&lt;n&gt;:UNIT:POWER</a> .....	125
<a href="#">DISPlay[:WINDow&lt;n&gt;][:SUBWindow&lt;w&gt;]:TRACe&lt;t&gt;:Y[:SCALe]:RLEVel</a> .....	126
<a href="#">DISPlay[:WINDow&lt;n&gt;][:SUBWindow&lt;w&gt;]:TRACe&lt;t&gt;:Y[:SCALe]:RLEVel:OFFSet</a> .....	126
<a href="#">INPut:ATTenuation:AUTO:MODE</a> .....	127
<a href="#">INPut:CONNector</a> .....	127
<a href="#">INPut:EGAIN[:STATe]</a> .....	127
<a href="#">INPut:GAIN:STATe</a> .....	128
<a href="#">INPut:GAIN[:VALue]</a> .....	128
<a href="#">INPut:ATTenuation</a> .....	128
<a href="#">INPut:ATTenuation:AUTO</a> .....	129
<a href="#">INPut:EATT</a> .....	129
<a href="#">INPut:EATT:AUTO</a> .....	130
<a href="#">INPut:EATT:STATe</a> .....	130

**CALCulate<n>:UNIT:POWER <Unit>**

Selects the power unit.

The unit applies to all power-based measurement windows with absolute values.

In addition, the unit of the reference level is adapted to the same unit.

**Suffix:**

<n>                         irrelevant

**Parameters:**

<Unit> DBM | V | A | W | DBPW | WATT | DBUV | DBMV | VOLT |  
 DBUA | AMPere  
 \*RST: dBm

**Example:**

CALC:UNIT:POW DBM  
 Sets the power unit to dBm.

**DISPlay[:WINDow<n>][:SUBWindow<w>]:TRACe<t>:Y[:SCALe]:RLEVel**  
 <ReferenceLevel>

Defines the reference level (for all traces in all windows).

With a reference level offset  $\neq 0$ , the value range of the reference level is modified by the offset.

**Suffix:**

<n> irrelevant  
 <w> subwindow  
 Not supported by all applications  
 <t> irrelevant

**Parameters:**

<ReferenceLevel> The unit is variable.  
 Range: see specifications document  
 \*RST: 0 dBm  
 Default unit: DBM

**Example:**

DISP:TRAC:Y:RLEV -60dBm

**Manual operation:** See "[Reference Level](#)" on page 54

**DISPlay[:WINDow<n>][:SUBWindow<w>]:TRACe<t>:Y[:SCALe]:RLEVel:OFFSet**  
 <Offset>

Defines a reference level offset (for all traces in all windows).

**Suffix:**

<n> irrelevant  
 <w> subwindow  
 Not supported by all applications  
 <t> irrelevant

**Parameters:**

<Offset> Range: -200 dB to 200 dB  
 \*RST: 0dB  
 Default unit: DB

**Example:**

DISP:TRAC:Y:RLEV:OFFS -10dB

**Manual operation:** See "[Shifting the Display \(Offset\)](#)" on page 55

**INPut:ATTenuation:AUTO:MODE** <OptMode>

Selects the priority for signal processing *after* the RF attenuation has been applied.

**Parameters:**

<OptMode> LNOise | LDISTortion

**LNOise**

Optimized for high sensitivity and low noise levels

**LDISTortion**

Optimized for low distortion by avoiding intermodulation

\*RST: LDISTortion (WLAN application: LNOise)

**Example:**

INP:ATT:AUTO:MODE LNO

**Manual operation:** See "[Optimization](#)" on page 57

**INPut:CONNector** <ConnType>

Determines which connector the input for the measurement is taken from.

**Parameters:**

<ConnType> **RF**  
RF input connector

**RFPRobe**

Active RF probe

\*RST: RF

**Example:**

INP:CONN RF

Selects input from the RF input connector.

**INPut:EGAIN[:STATe]** <State>

Before this command can be used, the external preamplifier must be connected to the R&S FSV/A. See the preamplifier's documentation for details.

When activated, the R&S FSV/A automatically compensates the magnitude and phase characteristics of the external preamplifier in the measurement results.

Note that when an optional external preamplifier is activated, the internal preamplifier is automatically disabled, and vice versa.

When deactivated, no compensation is performed even if an external preamplifier remains connected.

**Parameters:**

<State> ON | OFF | 0 | 1

**OFF | 0**

No data correction is performed based on the external preamplifier

**ON | 1**

Performs data corrections based on the external preamplifier

```
*RST: 0
```

**Example:** `INP:EGA ON`

#### **INPut:GAIN:STATe** <State>

Turns the internal preamplifier on and off. It requires the optional preamplifier hardware.

For R&S FSV/A44 models, note the restrictions described in "[Preamplifier](#)" on page 55.

#### **Parameters:**

<State>            ON | OFF | 0 | 1  
**OFF | 0**  
 Switches the function off  
**ON | 1**  
 Switches the function on

```
*RST: 0
```

**Example:** `INP:GAIN:STAT ON`  
`INP:GAIN:VAL 15`  
 Switches on 15 dB preamplification.

**Manual operation:** See "[Preamplifier](#)" on page 55

#### **INPut:GAIN[:VALue]** <Gain>

Selects the "gain" if the preamplifier is activated (`INP:GAIN:STAT ON`, see [INPut:GAIN:STATe](#) on page 128).

The command requires the additional preamplifier hardware option.

For R&S FSV/A44 or higher models, note the restrictions described in "[Preamplifier](#)" on page 55.

#### **Parameters:**

<Gain>            The following settings are available:  
 15 dB and 30 dB  
 All other values are rounded to the nearest of these two.  
 Default unit: DB

**Example:** `INP:GAIN:STAT ON`  
`INP:GAIN:VAL 30`  
 Switches on 30 dB preamplification.

**Manual operation:** See "[Preamplifier](#)" on page 55

#### **INPut:ATTenuation** <Attenuation>

Defines the total attenuation for RF input.



If you set the attenuation manually, it is no longer coupled to the reference level, but the reference level is coupled to the attenuation. Thus, if the current reference level is not compatible with an attenuation that has been set manually, the command also adjusts the reference level.

**Parameters:**

<Attenuation>      Range:      see specifications document  
 Increment:    5 dB (with optional electr. attenuator: 1 dB)  
 \*RST:        10 dB (AUTO is set to ON)  
 Default unit: DB

**Example:**

INP:ATT 30dB  
 Defines a 30 dB attenuation and decouples the attenuation from the reference level.

**Manual operation:** See "[Attenuation Mode / Value](#)" on page 56

**INPut:ATTenuation:AUTO <State>**

Couples or decouples the attenuation to the reference level. Thus, when the reference level is changed, the R&S FSV/A determines the signal level for optimal internal data processing and sets the required attenuation accordingly.

**Parameters:**

<State>            ON | OFF | 0 | 1  
 \*RST:            1

**Example:**

INP:ATT:AUTO ON  
 Couples the attenuation to the reference level.

**Manual operation:** See "[Attenuation Mode / Value](#)" on page 56

**INPut:EATT <Attenuation>**

Defines an electronic attenuation manually. Automatic mode must be switched off (INP:EATT:AUTO OFF, see [INPut:EATT:AUTO](#) on page 130).

If the current reference level is not compatible with an attenuation that has been set manually, the command also adjusts the reference level.

**Parameters:**

<Attenuation>      attenuation in dB  
 Range:            see specifications document  
 Increment:    1 dB  
 \*RST:            0 dB (OFF)  
 Default unit: DB

**Example:**

INP:EATT:AUTO OFF  
 INP:EATT 10 dB

**Manual operation:** See "[Using Electronic Attenuation](#)" on page 57

**INPut:EATT:AUTO** <State>

Turns automatic selection of the electronic attenuation on and off.

If on, electronic attenuation reduces the mechanical attenuation whenever possible.

**Parameters:**

<State>                    ON | OFF | 0 | 1  
**OFF | 0**  
 Switches the function off  
**ON | 1**  
 Switches the function on  
 \*RST:                    1

**Example:**                    INP:EATT:AUTO OFF

**Manual operation:**    See ["Using Electronic Attenuation"](#) on page 57

**INPut:EATT:STATe** <State>

Turns the electronic attenuator on and off.

**Parameters:**

<State>                    ON | OFF | 0 | 1  
**OFF | 0**  
 Switches the function off  
**ON | 1**  
 Switches the function on  
 \*RST:                    0

**Example:**                    INP:EATT:STAT ON  
 Switches the electronic attenuator into the signal path.

**Manual operation:**    See ["Using Electronic Attenuation"](#) on page 57

#### 9.4.4 Frequency settings

<a href="#">[SENSe:]FREQuency:CENTer</a> .....	130
<a href="#">[SENSe:]FREQuency:CENTer:STEP</a> .....	131
<a href="#">[SENSe:]FREQuency:CENTer:STEP:LINK</a> .....	131
<a href="#">[SENSe:]FREQuency:CENTer:STEP:LINK:FACTor</a> .....	132
<a href="#">[SENSe:]FREQuency:OFFSet</a> .....	132

**[SENSe:]FREQuency:CENTer** <Frequency>

Defines the center frequency.

**Parameters:**

<Frequency> For the allowed range and  $f_{max}$ , refer to the specifications document.

\*RST:  $f_{max}/2$

Default unit: Hz

**Example:**

```
FREQ:CENT 100 MHz
FREQ:CENT:STEP 10 MHz
FREQ:CENT UP
```

Sets the center frequency to 110 MHz.

**Manual operation:** See "Frequency" on page 59

**[SENSe:]FREQuency:CENTer:STEP <StepSize>**

Defines the center frequency step size.

**Parameters:**

<StepSize> For  $f_{max}$ , refer to the specifications document.

Range: 1 to  $f_{MAX}$

\*RST: 0.1 x span

Default unit: Hz

**Example:**

//Set the center frequency to 110 MHz.

```
FREQ:CENT 100 MHz
FREQ:CENT:STEP 10 MHz
FREQ:CENT UP
```

**[SENSe:]FREQuency:CENTer:STEP:LINK <CouplingType>**

Couples and decouples the center frequency step size to the span or the resolution bandwidth.

**Parameters:**

<CouplingType> SPAN | RBW | OFF

**SPAN**

Couples the step size to the span. Available for measurements in the frequency domain.

**OFF**

Decouples the step size.

\*RST: SPAN

**Example:**

```
//Couple step size to span
FREQ:CENT:STEP:LINK SPAN
```

---

**[SENSe:]FREQUENCY:CENTer:STEP:LINK:FACTor <Factor>**

**Parameters:**

<Factor> 1 to 100 PCT  
 \*RST: 10  
 Default unit: PCT

**Example:**

```
//Couple frequency step size to span and define a step size factor
FREQ:CENT:STEP:LINK SPAN
FREQ:CENT:STEP:LINK:FACT 20PCT
```

---

**[SENSe:]FREQUENCY:OFFSet <Offset>**

Defines a frequency offset.

If this value is not 0 Hz, the application assumes that the input signal was frequency shifted outside the application. All results of type "frequency" will be corrected for this shift numerically by the application.

**Parameters:**

<Offset> Range: -1 THz to 1 THz  
 \*RST: 0 Hz  
 Default unit: HZ

**Example:**

```
FREQ:OFFS 1GHZ
```

**Manual operation:** See "[Frequency Offset](#)" on page 53

## 9.4.5 Triggering measurements

The trigger commands define the beginning of a measurement.

Useful commands for triggering measurements described elsewhere:

- [\[SENSe:\]SWEep:TIME](#) on page 171

**Remote commands exclusive to triggering measurements:**

<a href="#">TRIGger[:SEQuence]:DTIME</a> .....	133
<a href="#">TRIGger[:SEQuence]:HOLDoff[:TIME]</a> .....	133
<a href="#">TRIGger[:SEQuence]:IFPower:HOLDoff</a> .....	133
<a href="#">TRIGger[:SEQuence]:IFPower:HYSTeresis</a> .....	133
<a href="#">TRIGger[:SEQuence]:LEVel[:EXTernal&lt;port&gt;]</a> .....	134
<a href="#">TRIGger[:SEQuence]:LEVel:IFPower</a> .....	134
<a href="#">TRIGger[:SEQuence]:SLOPe</a> .....	134
<a href="#">TRIGger[:SEQuence]:SOURce</a> .....	135
<a href="#">[SENSe:]BANDwidth[:RESolution]</a> .....	135

**TRIGger[:SEQuence]:DTIME** <DropoutTime>

Defines the time the input signal must stay below the trigger level before a trigger is detected again.

**Parameters:**

<DropoutTime> Dropout time of the trigger.  
 Range: 0 s to 10.0 s  
 \*RST: 0 s  
 Default unit: S

**Manual operation:** See "[Drop-Out Time](#)" on page 60

**TRIGger[:SEQuence]:HOLDoff[:TIME]** <Offset>

Defines the time offset between the trigger event and the start of the sweep.

**Parameters:**

<Offset> \*RST: 0 s  
 Default unit: S

**Example:** TRIG:HOLD 500us

**Manual operation:** See "[Trigger Offset](#)" on page 60

**TRIGger[:SEQuence]:IFPower:HOLDoff** <Period>

Defines the holding time before the next trigger event.

Note that this command can be used for **any trigger source**, not just IF Power (despite the legacy keyword).

**Parameters:**

<Period> Range: 0 s to 10 s  
 \*RST: 0 s  
 Default unit: S

**Example:** TRIG:SOUR EXT  
 Sets an external trigger source.  
 TRIG:IFP:HOLD 200 ns  
 Sets the holding time to 200 ns.

**Manual operation:** See "[Trigger Holdoff](#)" on page 61

**TRIGger[:SEQuence]:IFPower:HYSteresis** <Hysteresis>

Defines the trigger hysteresis, which is only available for "IF Power" trigger sources.

**Parameters:**

<Hysteresis> Range: 3 dB to 50 dB  
 \*RST: 3 dB  
 Default unit: DB

**Example:**           TRIG:SOUR IFP  
Sets the IF power trigger source.  
TRIG:IFP:HYST 10DB  
Sets the hysteresis limit value.

**Manual operation:** See "[Hysteresis](#)" on page 60

### TRIGger[:SEQuence]:LEVel[:EXTeRnal<port>] <TriggerLevel>

Defines the level the external signal must exceed to cause a trigger event.

**Suffix:**

<port>               Selects the trigger port.  
1 = trigger port 1 (TRIGGER INPUT connector on front panel)  
2 = trigger port 2 (TRIGGER INPUT/OUTPUT connector on front panel)  
3 = trigger port 3 (TRIGGER3 INPUT/OUTPUT connector on rear panel)

<port>               Selects the trigger port.  
1 = trigger port 1 (TRIG IN connector on rear panel)  
2 = trigger port 2 (TRIG AUX connector on rear panel)

**Parameters:**

<TriggerLevel>      Range:       0.5 V to 3.5 V  
                          \*RST:        1.4 V  
                          Default unit: V

**Example:**           TRIG:LEV 2V

**Manual operation:** See "[Trigger Level](#)" on page 60

### TRIGger[:SEQuence]:LEVel:IFPower <TriggerLevel>

Defines the power level at the third intermediate frequency that must be exceeded to cause a trigger event.

Note that any RF attenuation or preamplification is considered when the trigger level is analyzed. If defined, a reference level offset is also considered.

**Parameters:**

<TriggerLevel>      For details on available trigger levels and trigger bandwidths, see the specifications document.  
                          \*RST:        -20 dBm  
                          Default unit: DBM

**Example:**           TRIG:LEV:IFP -30DBM

### TRIGger[:SEQuence]:SLOPe <Type>

**Parameters:**

<Type>               POSitive | NEGative

**POSitive**

Triggers when the signal rises to the trigger level (rising edge).

**NEGative**

Triggers when the signal drops to the trigger level (falling edge).

\*RST: POSitive

**Example:** TRIG:SLOP NEG

**Manual operation:** See "[Slope](#)" on page 61

**TRIGger[:SEQUence]:SOURce <Source>**

Selects the trigger source.

**Note on external triggers:**

If a measurement is configured to wait for an external trigger signal in a remote control program, remote control is blocked until the trigger is received and the program can continue. Make sure that this situation is avoided in your remote control programs.

**Parameters:**

<Source>

**IMMediate**

Free Run

**EXTernal**

Trigger signal from the "Trigger Input" connector.

Trigger signal from the "Trigger In" connector.

**EXT2**

Trigger signal from the "Trigger Input/Output" connector.

Note: Connector must be configured for "Input".

Trigger signal from the "Trigger AUX" connector.

\*RST: IMMediate

**Example:** TRIG:SOUR EXT

Selects the external trigger input as source of the trigger signal

**Manual operation:** See "[Trigger Source](#)" on page 59  
See "[Free Run](#)" on page 59  
See "[External Trigger 1/2](#)" on page 60

**[SENSe:]BANDwidth[:RESolution] <Bandwidth>**

Defines the resolution bandwidth and decouples the resolution bandwidth from the span.

The 6 MHz Gaussian filter is provided for special measurements, such as 5G NR spurious emissions measurements. It is only available if you enter the value manually, not using the BAND:RES MAX command. It is not supported by all applications.

**Example:** BAND 1 MHz

Sets the resolution bandwidth to 1 MHz

**Manual operation:** See "[RBW](#)" on page 59

## 9.4.6 Gating

[SENSe:]SWEep:EGATe.....	136
[SENSe:]SWEep:EGATe:AUTO.....	136
[SENSe:]SWEep:EGATe:CONTinuous:PCOunt.....	137
[SENSe:]SWEep:EGATe:CONTinuous:PLENgtH.....	137
[SENSe:]SWEep:EGATe:CONTinuous[:STATe].....	137
[SENSe:]SWEep:EGATe:HOLDoff.....	138
[SENSe:]SWEep:EGATe:LENGth.....	138
[SENSe:]SWEep:EGATe:LEVel[:EXTeRnal<tp>].....	138
[SENSe:]SWEep:EGATe:LEVel:IFPower.....	139
[SENSe:]SWEep:EGATe:LEVel:RFPower.....	139
[SENSe:]SWEep:EGATe:POLarity.....	140
[SENSe:]SWEep:EGATe:SKIP.....	140
[SENSe:]SWEep:EGATe:SOURce.....	140
[SENSe:]SWEep:EGATe:TYPE.....	141

---

### [SENSe:]SWEep:EGATe <State>

Turns gated measurements on and off.

#### Parameters:

<State>                    ON | OFF | 0 | 1  
                               **OFF | 0**  
                               Switches the function off  
                               **ON | 1**  
                               Switches the function on

#### Example:

```
SWE:EGAT ON
Switches on the gate mode.
SWE:EGAT:TYPE EDGE
Switches on the edge-triggered mode.
SWE:EGAT:HOLD 100US
Sets the gate delay to 100 µs.
SWE:EGAT:LEN 500US
Sets the gate opening time to 500 µs.
INIT;*WAI
Starts a sweep and waits for its end.
```

**Manual operation:** See "[Gated Trigger](#)" on page 62

---

### [SENSe:]SWEep:EGATe:AUTO <State>

Determines whether the same or different triggers are used for general measurement and gating.

#### Parameters:

<State>                    ON | OFF | 0 | 1



**OFF | 0**

The gate is opened by the trigger source defined by [SENSe:]SWEep:EGATe:SOURce, but only after a trigger from the general TRIGger[:SEQuence]:SOURce occurs.

**ON | 1**

(Default:) The trigger defined by TRIGger[:SEQuence]:SOURce is used both for the general measurement trigger and the gating trigger.

\*RST: 1

**Example:**

```
SENS:SWE:EGAT:AUTO 0
SENS:SWE:EGAT:SOUR EXT2
SENS:SWE:EGAT:LEV:EXT2 1V
Sets the gating trigger to a level of 1 V at trigger port 2.
```

**[SENSe:]SWEep:EGATe:CONTInuous:PCOunt <Amount>**

Defines the number of gate periods to be measured after a single trigger event.

**Parameters:**

<Amount> integer  
 Range: 1 to 65535  
 Increment: 1  
 \*RST: 100

**Example:**

```
SWE:EGAT:CONT:PCO 50
```

**[SENSe:]SWEep:EGATe:CONTInuous:PLENgtH <Time>**

Defines the length in seconds of a single gate period in continuous gating. The length is determined from the beginning of one gate measurement to the beginning of the next one.

**Parameters:**

<Time> Range: 125 ns to 16 s  
 \*RST: 5 ms  
 Default unit: S

**Example:**

```
SWE:EGAT:CONT:PLEN 10
```

**[SENSe:]SWEep:EGATe:CONTInuous[:STATe] <State>**

Activates or deactivates continuous gating.

This setting is only available if [SENSe:]SWEep:EGATe is "On".

**Parameters:**

<State> ON | OFF | 0 | 1  
**OFF | 0**  
 Switches the function off

**ON | 1**

Switches the function on

\*RST: 0

**Example:**

SWE:EGAT ON

Activate gating

SWE:EGAT:CONT:STAT ON

Activate continuous gating

**[SENSe:]SWEep:EGATe:HOLDoff <DelayTime>**

Defines the delay time between the gate signal and the continuation of the measurement.

**Parameters:**

<DelayTime> Range: 0 s to 30 s  
 \*RST: 0 s  
 Default unit: S

**Example:**

SWE:EGAT:HOLD 100us

**Manual operation:** See "[Gate Delay](#)" on page 62**[SENSe:]SWEep:EGATe:LENGth <GateLength>**

Defines the gate length.

**Parameters:**

<GateLength> Range: 125 ns to 30 s  
 \*RST: 400µs  
 Default unit: S

**Example:**

SWE:EGAT:LENG 10ms

**Manual operation:** See "[Gate Length](#)" on page 62**[SENSe:]SWEep:EGATe:LEVel[:EXTeRnal<tp>] <GateLevel>**

Defines the gate level for which the gate is open.

Is only available for triggered gated measurements ([SENSe:]SWEep:EGATe:AUTOMAN).

**Suffix:**

<tp> Selects the trigger port.  
 1 = trigger port 1 (TRIGGER INPUT connector on front panel)  
 2 = trigger port 2 (TRIGGER INPUT/OUTPUT connector on front panel)  
 3 = trigger port 3 (TRIGGER3 INPUT/OUTPUT connector on rear panel)

**Parameters:**

<GateLevel> numeric value  
 Range: 0.5 V to 3.5 V  
 \*RST: 1.4 V  
 Default unit: V

**Example:**

```
SENS:SWE:EGAT:AUTO MAN
SENS:SWE:EGAT:SOUR EXT2
SENS:SWE:EGAT:LEV:EXT2 1V
```

Sets the gating trigger to a level of 1 V at trigger port 2.

**[SENSe:]SWEep:EGATe:LEVel:IFPower <GateLevel>**

Defines the the power level at the third intermediate frequency that must be exceeded for the gate to be open.

Note that any RF attenuation or preamplification is considered when the trigger level is analyzed. If defined, a reference level offset is also considered.

Is only available for triggered gated measurements (`[SENSe:]SWEep:EGATe:AUTO MAN`).

**Parameters:**

<GateLevel> For details on available trigger levels and trigger bandwidths see the specifications document.  
 \*RST: -10 dBm  
 Default unit: DBM

**Example:**

```
SENS:SWE:EGAT:AUTO MAN
SENS:SWE:EGAT:SOUR IFP
SENS:SWE:EGAT:LEV:IFP 0
```

Sets the gating trigger to a level of 0 dBm at the third IF.

**[SENSe:]SWEep:EGATe:LEVel:RFPower <GateLevel>**

Defines the gate level for which the gate is open. Note that any RF attenuation or pre-amplification is considered when the trigger level is analyzed. If defined, a reference level offset is also considered.

The input signal must be between 500 MHz and 8 GHz.

Is only available for triggered gated measurements (`[SENSe:]SWEep:EGATe:AUTO MAN`).

**Parameters:**

<GateLevel> For details on available trigger levels and trigger bandwidths, refer to the specifications document.  
 \*RST: -20 dBm  
 Default unit: DBM

**Example:**

```
SENS:SWE:EGAT:AUTO MAN
SENS:SWE:EGAT:SOUR RFP
SENS:SWE:EGAT:LEV:RFP -10
```

Sets the gating trigger to a level of -10 dBm at the RF input.

#### [SENSe:]SWEep:EGATe:POLarity <Polarity>

Selects the polarity of an external gate signal.

The setting applies both to the edge of an edge-triggered signal and the level of a level-triggered signal.

#### Parameters:

<Polarity>            POSitive | NEGative  
\*RST:                POSitive

**Example:**            SWE:EGAT:POL POS

**Manual operation:** See "[Slope](#)" on page 61

#### [SENSe:]SWEep:EGATe:SKIP <Comment>

Ignores the specified gates in a continuous gate measurement. This setting is only available for magnitude (offline) triggered measurements.

#### Parameters:

<Comment>            String containing a comma-separated list of gate numbers to be ignored during a measurement.

**Example:**            SENS:SWEE:EGAT:SKIP '1,4-5'

#### [SENSe:]SWEep:EGATe:SOURce <Source>

Selects the signal source for gated measurements.

If an IF power signal is used, the gate is opened as soon as a signal at > -20 dBm is detected within the IF path bandwidth (10 MHz).

For more information see "[Trigger Source](#)" on page 59.

#### Parameters:

<Source>                \*RST:                IFPower

**Example:**            SWE:EGAT:SOUR IFP  
Switches the gate source to IF power.

---

**[SENSe:]SWEep:EGATe:TYPE <Type>**

Selects the way gated measurements are triggered.

**Parameters:**

<Type>

**LEVel**

The trigger event for the gate to open is a particular power level. After the gate signal has been detected, the gate remains open until the signal disappears.

**EDGE**

The trigger event for the gate to open is the detection of the signal edge.

After the gate signal has been detected, the gate remains open until the gate length is over.

\*RST: EDGE

**Example:**

SWE:EGAT:TYPE EDGE

**Manual operation:** See "[Gate Mode](#)" on page 62

## 9.4.7 Adjusting settings automatically

The following remote commands are required to adjust settings automatically in a remote environment.

<a href="#">[SENSe:]ADJust:CONFigure:LEVel:DURation</a> .....	141
<a href="#">[SENSe:]ADJust:CONFigure:LEVel:DURation:MODE</a> .....	142
<a href="#">[SENSe:]ADJust:CONFigure:HYSteresis:LOWer</a> .....	142
<a href="#">[SENSe:]ADJust:CONFigure:HYSteresis:UPPer</a> .....	142
<a href="#">[SENSe:]ADJust:LEVel</a> .....	143

---

**[SENSe:]ADJust:CONFigure:LEVel:DURation <Duration>**

To determine the ideal reference level, the R&S FSV/A performs a measurement on the current input data. This command defines the length of the measurement if

[\[SENSe:\]ADJust:CONFigure:LEVel:DURation:MODE](#) is set to `MANual`.

**Parameters:**

<Duration>

Numeric value in seconds

Range: 0.001 to 16000.0

\*RST: 0.001

Default unit: s

**Example:**

ADJ:CONF:DUR:MODE MAN

Selects manual definition of the measurement length.

ADJ:CONF:LEV:DUR 5ms

Length of the measurement is 5 ms.

**Manual operation:** See "[Changing the Automatic Measurement Time \(Meas Time Manual\)](#)" on page 70

**[SENSe:]ADJust:CONFigure:LEVel:DURation:MODE <Mode>**

To determine the ideal reference level, the R&S FSV/A performs a measurement on the current input data. This command selects the way the R&S FSV/A determines the length of the measurement .

**Parameters:**

&lt;Mode&gt;

**AUTO**

The R&S FSV/A determines the measurement length automatically according to the current input data.

**MANual**

The R&S FSV/A uses the measurement length defined by [\[SENSe:\]ADJust:CONFigure:LEVel:DURation](#) on page 141.

\*RST: AUTO

**Manual operation:** See ["Resetting the Automatic Measurement Time \(Meas Time Auto\)"](#) on page 70  
See ["Changing the Automatic Measurement Time \(Meas Time Manual\)"](#) on page 70

**[SENSe:]ADJust:CONFigure:HYSTeresis:LOWer <Threshold>****Parameters:**

&lt;Threshold&gt;

Range: 0 dB to 200 dB

\*RST: +1 dB

Default unit: dB

**Example:**

SENS:ADJ:CONF:HYST:LOW 2

For an input signal level of currently 20 dBm, the reference level is only adjusted when the signal level falls below 18 dBm.

**Manual operation:** See ["Lower Level Hysteresis"](#) on page 71

**[SENSe:]ADJust:CONFigure:HYSTeresis:UPPer <Threshold>****Parameters:**

&lt;Threshold&gt;

Range: 0 dB to 200 dB

\*RST: +1 dB

Default unit: dB

**Example:**

SENS:ADJ:CONF:HYST:UPP 2

**Example:**

For an input signal level of currently 20 dBm, the reference level is only adjusted when the signal level rises above 22 dBm.

**Manual operation:** See ["Upper Level Hysteresis"](#) on page 70

**[SENSe:]ADJust:LEVel**

Initiates a single (internal) measurement that evaluates and sets the ideal reference level for the current input data and measurement settings. Thus, the settings of the RF attenuation and the reference level are optimized for the signal level. The R&S FSV/A is not overloaded and the dynamic range is not limited by an S/N ratio that is too small.

**Example:** ADJ:LEV

**Manual operation:** See "[Setting the Reference Level Automatically \(Auto Level\)](#)" on page 70

## 9.4.8 Configuring Modulation Characteristics measurements

- [Data acquisition](#)..... 143
- [Burst synchronization](#)..... 144
- [Demodulation](#)..... 147

### 9.4.8.1 Data acquisition

- [CONFigure:BT0oth:MEASurement:BWIDth?](#)..... 143
- [CONFigure:BT0oth:MEASurement:FILTer](#)..... 143
- [CONFigure:BT0oth:PTYPe](#)..... 144

---

#### **CONFigure:BT0oth:MEASurement:BWIDth?**

Queries the used demodulation bandwidth, which depends on whether or not a measurement filter is used.

If the measurement filter is used, the demodulation bandwidth is 1.3 MHz. Otherwise, it is 3 MHz.

**Example:** Query whether measurement filter is used.  
 CONF:BT0:MEAS:FILT?  
 //Result: 0  
 Query the demodulation bandwidth.  
 CONF:BT0:MEAS:BWID?  
 //Result: 3000000

**Usage:** Query only

**Manual operation:** See "[Demodulation Bandwidth](#)" on page 64

---

#### **CONFigure:BT0oth:MEASurement:FILTer <State>**

Enables or disables the use of an optional measurement filter (see [Chapter 3.2.1, "Measurement filter"](#), on page 30).

**Parameters:**  
 <State> ON | OFF | 0 | 1

**OFF | 0**

Switches the function off

**ON | 1**

Switches the function on

\*RST: 0

**Example:** CONF:BTO:MEAS:FILT ON**Manual operation:** See "[Meas Filter](#)" on page 63**CONFigure:BT0oth:PTYPe** <PacketType>

Defines the packet type used in the Bluetooth signal and thus the required capture time.

**Parameters:**

&lt;PacketType&gt;

**DH1**

Captures one slot

**DH3**

Captures 3 slots

**DH5**

Captures 5 slots

**AUTO**

For BR + EDR: captures 5 slots

For LE: The R&amp;S FSV3 Bluetooth measurement application determines the required capture time to cover the payload automatically.

**LE1M | LE2M | LECODED**

For LE, the R&amp;S FSV3 Bluetooth measurement application determines the required capture time to cover the payload automatically.

**Example:** CONF:BTO:PTYP DH3**Manual operation:** See "[Capture Time](#)" on page 64**9.4.8.2 Burst synchronization**

CONFigure:BT0oth:SEARch:PULSe:STATe.....	145
CONFigure:BT0oth:SEARch:SYNC:LAP:AUTO.....	145
CONFigure:BT0oth:SEARch:SYNC:LAP.....	145
CONFigure:BT0oth:SEARch:SYNC:STATe.....	146
CONFigure:BT0oth:SEARch:SYNC:UAP:AUTO.....	146
CONFigure:BT0oth:SEARch:SYNC:UAP.....	146



**CONFigure:BT0oth:SEARch:PULSe:STATe** <SearchBurstMode>

Enables or disables the search for a signal burst based on the measured power. If both [CONFigure:BT0oth:SEARch:SYNC:STATe](#) ON and [CONFigure:BT0oth:SEARch:PULSe:STATe](#) ON, the search area for the sync word is limited to the detected burst.

**Parameters:**

<SearchBurstMode>

**Example:**

CONFigure:BT0oth:SEARch:PULSe:STATe ON

**CONFigure:BT0oth:SEARch:SYNC:LAP:AUTO** <State>

Defines how the LAP is determined.

Not available for LE signals.

**Parameters:**

<State>

ON | OFF | 0 | 1

**OFF | 0**

Define the LAP manually using [CONFigure:BT0oth:SEARch:SYNC:LAP](#) on page 145

**ON | 1**

The R&S FSV3 Bluetooth measurement application determines the LAP automatically

\*RST: 0

**Example:**

CONF:BT0:SEAR:SYNC:LAP:AUTO 0  
CONF:BT0:SEAR:SYNC:LAP 80

**Manual operation:** See "[LAP \(Low Address Part \[hex\]\)](#)" on page 65

**CONFigure:BT0oth:SEARch:SYNC:LAP** <LAP>

Sets or queries the lower address part of the Bluetooth device address (LAP, the 24 least significant bits). The LAP determines the sync word used for sync search.

This command is not available for LE mode.

**Parameters:**

<LAP>

hexadecimal number

Range: #H0x000000 to #H0xfffff

\*RST: #H0x0001

**Example:**

CONFigure:BT0oth:SEARch:SYNC:LAP #H0x0001

**Manual operation:** See "[LAP \(Low Address Part \[hex\]\)](#)" on page 65

**CONFigure:BT0oth:SEARch:SYNC:STATE** <State>

Enables or disables the search for the sync word. The only results that can be determined without synchronization are the output power results. See "[Synchronization](#)" on page 29.

**Parameters:**

<State>                    ON | OFF | 0 | 1  
**OFF | 0**  
 Switches the function off  
**ON | 1**  
 Switches the function on  
 \*RST:                    0

**Example:**                    CONFigure:BT0oth:SEARch:SYNC:STATE ON

**CONFigure:BT0oth:SEARch:SYNC:UAP:AUTO** <Mode>

Defines how the upper address part of the Bluetooth device address (UAP, the 24 most significant bits) used for the CRC/HEC error correction check is determined.

Not available for LE signals.

**Parameters:**

<Mode>                    ON | OFF | 0 | 1  
**OFF | 0**  
 Define the UAP manually using [CONFigure:BT0oth:SEARch:SYNC:UAP](#) on page 146  
**ON | 1**  
 The R&S FSV3 Bluetooth measurement application determines the UAP automatically  
 \*RST:                    0

**Example:**                    CONF:BT0:SEAR:SYNC:UAP:AUTO 0  
 CONF:BT0:SEAR:SYNC:UAP 48

**Manual operation:**    See "[UAP \(Upper Address Part \[hex\]\)](#)" on page 65

**CONFigure:BT0oth:SEARch:SYNC:UAP** <UAP>

Defines the upper address part of the Bluetooth device address (UAP, the 24 most significant bits) used for the CRC/HEC error correction check. Only required if the UAP is not determined automatically ([CONFigure:BT0oth:SEARch:SYNC:UAP:AUTO](#) OFF).

Not available for LE signals.

**Parameters:**

<UAP>                    numeric value in hexadecimal format

**Example:**                    CONF:BT0:SEAR:SYNC:UAP:AUTO 0  
 CONF:BT0:SEAR:SYNC:UAP 48

**Manual operation:** See "[UAP \(Upper Address Part \[hex\]\)](#)" on page 65

### 9.4.8.3 Demodulation

<a href="#">[SENSe:]CORRection:EGain:INPut[:MAGNitude]</a> .....	147
<a href="#">CONFigure:BT0oth:PBSCo</a> .....	147

---

#### **[SENSe:]CORRection:EGain:INPut[:MAGNitude]** <External Gain>

Defines an external gain that the R&S FSV3 Bluetooth measurement application takes into account for the measurement results.

The value depends on the used standard. See also [Chapter 5.2, "Configuration according to digital standards"](#), on page 46 .

**Parameters:**

<External Gain>            numeric value  
                                  Range:        -200 to +200  
                                  \*RST:        0  
                                  Default unit: DB

**Example:**                    CORR:EGA:INP 10DB  
                                  Takes 10 dB external gain into account.

**Manual operation:** See "[Antenna Gain](#)" on page 66

---

#### **CONFigure:BT0oth:PBSCo** <PayloadSize>

Defines the number of payload bytes for SCO packets. SCO packets do not have a payload header.

**Parameters:**

<PayloadSize>            integer  
                                  Range:        1 to 1000  
                                  \*RST:        1

**Example:**                    CONF:BT0:PBSC 50

**Manual operation:** See "[Packet Bytes SCO](#)" on page 66

## 9.4.9 Configuring In-band Spurious Emissions measurements

---

#### **CONFigure:BT0oth:CHANnel** <Tx>

Selects the transmit channel within the Bluetooth signal. Measurement results are based on this channel. The value range depends on the channel format, see [CONFigure:BT0oth:CHFormat](#) on page 148.

**Parameters:**

<Tx>                            integer  
                                  Range:        0 to 40/80

**Example:** `CONF:BTO:CHAN 39`

**Manual operation:** See ["Channel No"](#) on page 67  
See ["TX Channel"](#) on page 67

---

### **CONFigure:BT0oth:CHFormat** <Format>

Toggles the channel numbers between common TX and specific LE numbering. The channel format also applies to the ["Number of Captured Channels"](#) on page 86.

This setting is only available for BT LE mode.

#### **Parameters:**

<Format> TX | LE

#### **TX**

Each channel has a bandwidth of 1 MHz, with channel numbers ranging from 0 to 78.

#### **LE**

Each channel has a bandwidth of 2 MHz, with channel numbers ranging from 0 to 40.

**Manual operation:** See ["Channel Format"](#) on page 67

## 9.5 Performing a measurement

When the R&S FSV3 Bluetooth measurement application is activated, a continuous sweep is performed automatically. However, you can stop and start a new measurement any time.

Furthermore, you can perform a sequence of measurements using the Sequencer (see ["Multiple Channels and Sequencer Function"](#) on page 9).

<a href="#">ABORT</a> .....	148
<a href="#">INITiate&lt;n&gt;:CONMeas</a> .....	149
<a href="#">INITiate&lt;n&gt;:CONTinuous</a> .....	149
<a href="#">INITiate&lt;n&gt;:[IMMediate]</a> .....	150
<a href="#">INITiate:SEQuencer:ABORT</a> .....	150
<a href="#">INITiate:SEQuencer:IMMediate</a> .....	150
<a href="#">INITiate:SEQuencer:MODE</a> .....	151
<a href="#">SYSTem:SEQuencer</a> .....	151

---

### **ABORT**

Aborts the measurement in the current channel and resets the trigger system.

To prevent overlapping execution of the subsequent command before the measurement has been aborted successfully, use the `*OPC?` or `*WAI` command after `ABOR` and before the next command.

For details on overlapping execution see [Remote control via SCPI](#).

**Note on blocked remote control programs:**

If a sequential command cannot be completed, for example because a triggered sweep never receives a trigger, the remote control program will never finish and the remote channel to the R&S FSV/A is blocked for further commands. In this case, you must interrupt processing on the remote channel first in order to abort the measurement.

To do so, send a "Device Clear" command from the control instrument to the R&S FSV/A on a parallel channel to clear all currently active remote channels. Depending on the used interface and protocol, send the following commands:

- **Visa:** `viClear()`

Now you can send the `ABORT` command on the remote channel performing the measurement.

**Example:** `ABOR; :INIT:IMM`  
Aborts the current measurement and immediately starts a new one.

**Example:** `ABOR; *WAI`  
`INIT:IMM`  
Aborts the current measurement and starts a new one once abortion has been completed.

**Usage:** Event

**INITiate<n>:CONMeas**

Restarts a (single) measurement that has been stopped (using `ABORT`) or finished in single sweep mode.

The measurement is restarted at the beginning, not where the previous measurement was stopped.

**Suffix:**  
<n> irrelevant

**Usage:** Asynchronous command

**INITiate<n>:CONTInuous <State>**

Controls the sweep mode for an individual channel.

Note that in single sweep mode, you can synchronize to the end of the measurement with `*OPC`, `*OPC?` or `*WAI`. In continuous sweep mode, synchronization to the end of the measurement is not possible. Thus, it is not recommended that you use continuous sweep mode in remote control, as results like trace data or markers are only valid after a single sweep end synchronization.

For details on synchronization see [Remote control via SCPI](#).

**Suffix:**

<n> irrelevant

**Parameters:**

<State> ON | OFF | 0 | 1

**ON | 1**

Continuous sweep

**OFF | 0**

Single sweep

\*RST: 1 (some applications can differ)

**Example:**

```
INIT:CONT OFF
```

Switches the sweep mode to single sweep.

```
INIT:CONT ON
```

Switches the sweep mode to continuous sweep.

**Manual operation:** See "[Continuous Sweep / Run Cont](#)" on page 68

**INITiate<n>[:IMMEDIATE]**

Starts a (single) new measurement.

You can synchronize to the end of the measurement with \*OPC, \*OPC? or \*WAI.

For details on synchronization see [Remote control via SCPI](#).

**Suffix:**

<n> irrelevant

**Usage:**

Asynchronous command

**Manual operation:** See "[Single Sweep / Run Single](#)" on page 68

**INITiate:SEQuencer:ABORt**

Stops the currently active sequence of measurements.

You can start a new sequence any time using [INITiate:SEQuencer:IMMEDIATE](#) on page 150.

**Usage:**

Event

**INITiate:SEQuencer:IMMEDIATE**

Starts a new sequence of measurements by the Sequencer.

Before this command can be executed, the Sequencer must be activated (see [SYSTem:SEQuencer](#) on page 151).

**Example:**

```

SYST:SEQ ON
Activates the Sequencer.
INIT:SEQ:MODE SING
Sets single sequence mode so each active measurement is performed once.
INIT:SEQ:IMM
Starts the sequential measurements.

```

---

#### **INITiate:SEQuencer:MODE <Mode>**

Defines the capture mode for the entire measurement sequence and all measurement groups and channels it contains.

**Note:** To synchronize to the end of a measurement sequence using \*OPC, \*OPC? or \*WAI, use SINGle Sequencer mode.

#### **Parameters:**

<Mode>

##### **SINGle**

Each measurement group is started one after the other in the order of definition. All measurement channels in a group are started simultaneously and performed once. After *all* measurements are completed, the next group is started. After the last group, the measurement sequence is finished.

##### **CONTInuous**

Each measurement group is started one after the other in the order of definition. All measurement channels in a group are started simultaneously and performed once. After *all* measurements are completed, the next group is started. After the last group, the measurement sequence restarts with the first one and continues until it is stopped explicitly.

\*RST:       CONTInuous

---

#### **SYSTem:SEQuencer <State>**

Turns the Sequencer on and off. The Sequencer must be active before any other Sequencer commands (INIT:SEQ. . .) are executed, otherwise an error occurs.

#### **Parameters:**

<State>

ON | OFF | 0 | 1

##### **ON | 1**

The Sequencer is activated and a sequential measurement is started immediately.

##### **OFF | 0**

The Sequencer is deactivated. Any running sequential measurements are stopped. Further Sequencer commands (INIT:SEQ. . .) are not available.

\*RST:       0

**Example:**

```

SYST:SEQ ON
Activates the Sequencer.
INIT:SEQ:MODE SING
Sets single Sequencer mode so each active measurement is
performed once.
INIT:SEQ:IMM
Starts the sequential measurements.
SYST:SEQ OFF

```

## 9.6 Analyzing Bluetooth BR/EDR/LE measurements

- [Analyzing modulation characteristics](#)..... 152
- [Analyzing in-band spurious emissions](#)..... 169
- [Working with markers](#)..... 175

### 9.6.1 Analyzing modulation characteristics

- [BR and LE signals](#)..... 152
- [EDR signals](#)..... 162

#### 9.6.1.1 BR and LE signals

- [Power range](#)..... 152
- [Result statistics](#)..... 153
- [Defining limit checks](#)..... 153

#### Power range

[CONFigure:BT0oth:POWer:AVERage:STARt](#)..... 152

[CONFigure:BT0oth:POWer:AVERage:STOP](#)..... 153

---

**CONFigure:BT0oth:POWer:AVERage:STARt** <Position>

Start position of the power range in which the average maximum power is determined.

**Parameters:**

<Position>                      Percentage of the burst length

Range:                      0 to 100

\*RST:                      20

Default unit: PCT

**Example:**

```

CONF:BT0:POW:AVER:STAR 20
CONF:BT0:POW:AVER:STOP 80

```

**Manual operation:** See "[Output Power Start / Output Power Stop](#)" on page 73



**CONFigure:BT0oth:POWER:AVERage:STOP** <Position>

Stop position of the power range in which the average maximum power is determined.

**Parameters:**

<Position> Percentage of the burst length  
 Range: 0 to 100  
 \*RST: 80  
 Default unit: PCT

**Example:**

```
CONF: BTO: POW: AVER: STAR 20
CONF: BTO: POW: AVER: STOP 80
```

**Manual operation:** See ["Output Power Start / Output Power Stop"](#) on page 73

**Result statistics****CONFigure:BT0oth:CRC:MOPass** <State>

Determines which packets are considered for statistical results.

**Parameters:**

<State> ON | OFF | 0 | 1  
**OFF | 0**  
 All bursts are included in the result statistics  
**ON | 1**  
 Only packets which pass the CRC/HEC error correction check are considered for statistical results.  
 \*RST: 0

**Manual operation:** See ["Results Statistics: Measure only if CRC/HEC is correct"](#) on page 73

**Defining limit checks**

CALCulate<n>:LIMit:TRACe<t>:CHECK.....	154
CONFigure:BT0oth:DH<pt>:FDRift:LLIMit.....	154
CONFigure:BT0oth:DH<pt>:FDRift:ULIMit.....	155
CONFigure:BT0oth:DH<pt>:MDRate:LLIMit.....	155
CONFigure:BT0oth:DH<pt>:MDRate:ULIMit.....	155
CONFigure:BT0oth:FDRift:LLIMit.....	156
CONFigure:BT0oth:FDRift:ULIMit.....	156
CONFigure:BT0oth:FOFFset:LLIMit.....	156
CONFigure:BT0oth:FOFFset:ULIMit.....	157
CONFigure:BT0oth:ICFTolerance:LLIMit.....	157
CONFigure:BT0oth:ICFTolerance:ULIMit.....	157
CONFigure:BT0oth:IFDRift:LLIMit.....	158
CONFigure:BT0oth:IFDRift:ULIMit.....	158
CONFigure:BT0oth:MDRate:LLIMit.....	158
CONFigure:BT0oth:MDRate:ULIMit.....	159
CONFigure:BT0oth:MODulation:F1AVerage:LLIMit.....	159

CONFigure:BT0oth:MODulation:F1AverAge:ULIMit.....	159
CONFigure:BT0oth:MODulation:F1Max:IRANge.....	160
CONFigure:BT0oth:MODulation:F1Max:LLIMit.....	160
CONFigure:BT0oth:MODulation:FDIVision:LLIMit.....	160
CONFigure:BT0oth:MODulation:F2Max:IRANge.....	160
CONFigure:BT0oth:MODulation:F2Max:LLIMit.....	161
CONFigure:BT0oth:POWer:AVERAge:LLIMit.....	161
CONFigure:BT0oth:POWer:AVERAge:ULIMit.....	161
CONFigure:BT0oth:POWer:PEAK:RLIMit.....	162
CONFigure:BT0oth:POWer:PEAK:ULIMit.....	162

---

### CALCulate<n>:LIMit:TRACe<t>:CHECK <State>

Enables or disables a limit check for the measured results.

Note that this command replaces the two commands from previous signal and spectrum analyzers (which are still supported): CALCulate<n>:LIMit<li>:TRACe<t> + CALCulate<n>:LIMit<li>:STATe.

#### Suffix:

<n>	irrelevant
<t>	irrelevant

#### Parameters:

<State>	ON   OFF   0   1
	<b>OFF   0</b>
	Switches the function off
	<b>ON   1</b>
	Switches the function on
*RST:	0

**Example:** CALC:LIM:TRAC2:CHEC ON  
Enables a limit check on trace 2.

**Manual operation:** See "Limit Check" on page 74  
See "Limit Check" on page 81

---

### CONFigure:BT0oth:DH<pt>:FDRift:LLIMit <LowerLimit>

Defines the lower limit for the frequency drift for the specified packet type.

#### Suffix:

<pt>	1   3   5
	packet type: 1, 3, or 5 slots

#### Parameters:

<LowerLimit>	numeric value
	Range: -500000 to 500000
*RST:	DH1: -25000; DH3, DH5: -40000
	Default unit: HZ

**Example:**            `CALC:LIM:TRAC:CHEC ON`  
                           `CONF:BTO:DH1:FDR:LLIM -80000`

**Manual operation:** See "[Freq Drift Upper / Freq Drift Lower](#)" on page 76

**CONFigure:BTOoth:DH<pt>:FDRift:ULIMit** <UpperLimit>

Defines the upper limit for the frequency drift for the specified packet type.

**Suffix:**

<pt>                    1 | 3 | 5  
                           packet type: 1, 3, or 5 slots

**Parameters:**

<UpperLimit>        numeric value  
                           Range:        -500000 to 500000  
                           \*RST:        DH1: 25000; DH3, DH5: 40000  
                           Default unit: HZ

**Example:**            `CALC:LIM:TRAC:CHEC ON`  
                           `CONF:BTO:DH1:FDR:ULIM 80000`

**Manual operation:** See "[Freq Drift Upper / Freq Drift Lower](#)" on page 76

**CONFigure:BTOoth:DH<pt>:MDRate:LLIMit** <LowerLimit>

Defines the lower limit for the maximum frequency drift rate.

**Suffix:**

<pt>                    1 | 3 | 5  
                           packet type: 1, 3, or 5 slots

**Parameters:**

<LowerLimit>        numeric value  
                           Range:        -500000 to 500000  
                           \*RST:        20000  
                           Default unit: HZ

**Example:**            `CALC:LIM:TRAC:CHEC ON`  
                           `CONF:BTO:DH1:MDR:LLIM 8000`

**Manual operation:** See "[Max Drift Rate Upper / Max Drift Rate Lower](#)" on page 76

**CONFigure:BTOoth:DH<pt>:MDRate:ULIMit** <UpperLimit>

Defines the upper limit for the maximum frequency drift rate.

**Suffix:**

<pt>                    1 | 3 | 5  
                           packet type: 1, 3, or 5 slots

**Parameters:**

<UpperLimit> numeric value  
 Range: -500000 to 500000  
 \*RST: -20000  
 Default unit: HZ

**Example:**

```
CALC:LIM:TRAC:CHEC ON
CONF:BTO:DH1:MDR:ULIM -8000
```

**Manual operation:** See "[Max Drift Rate Upper / Max Drift Rate Lower](#)" on page 76

**CONFigure:BTOoth:FDRift:LLIMit <LowerLimit>**

Defines the lower limit for the frequency drift in LE signals.

**Parameters:**

<LowerLimit> numeric value  
 The lower limit must be at least 1 kHz lower than the upper limit.  
 Range: -500000 to 500000  
 \*RST: -50000  
 Default unit: HZ

**Example:**

```
CALC:LIM:TRAC:CHEC ON
CONF:BTO:FDR:LLIM -50000
```

**Manual operation:** See "[Freq Drift Upper / Freq Drift Lower](#)" on page 76

**CONFigure:BTOoth:FDRift:ULIMit <UpperLimit>**

Defines the upper limit for the frequency drift in LE signals.

**Parameters:**

<UpperLimit> numeric value  
 The upper limit must be at least 1 kHz higher than the lower limit.  
 Range: -500000 to 500000  
 \*RST: 50000  
 Default unit: HZ

**Example:**

```
CALC:LIM:TRAC:CHEC ON
CONF:BTO:FDR:ULIM 50000
```

**Manual operation:** See "[Freq Drift Upper / Freq Drift Lower](#)" on page 76

**CONFigure:BTOoth:FOFFset:LLIMit <LowerLimit>**

Defines the lower limit for the frequency offset in LE signals.

**Parameters:****<LowerLimit>** numeric value

The lower limit must be at least 1 kHz lower than the upper limit.

Range: -500000 to 500000

\*RST: -150000

Default unit: HZ

**Example:**

```
CALC:LIM:TRAC:CHEC ON
CONF:BTO:FOFF:LLIM -50000
```

**Manual operation:** See "[Freq Offset Upper / Lower](#)" on page 78**CONFigure:BTOoth:FOFFset:ULIMit <UpperLimit>**

Defines the upper limit for the frequency offset in LE signals.

**Parameters:****<UpperLimit>** numeric value

The upper limit must be at least 1 kHz higher than the lower limit.

Range: -500000 to 500000

\*RST: 150000

Default unit: HZ

**Example:**

```
CALC:LIM:TRAC:CHEC ON
CONF:BTO:FODD:ULIM 50000
```

**Manual operation:** See "[Freq Offset Upper / Lower](#)" on page 78**CONFigure:BTOoth:ICFTolerance:LLIMit <LowerLimit>**

Defines the lower limit for the initial carrier frequency tolerance (ICFT).

**Parameters:****<LowerLimit>** numeric value

The lower limit must be at least 1 kHz lower than the upper limit.

Range: -500000 to 500000

\*RST: -75000

Default unit: HZ

**Example:**

```
CALC:LIM:TRAC:CHEC ON
CONF:BTO:ICFT:LLIM -80000
```

**Manual operation:** See "[ICFT Upper / ICFT Lower](#)" on page 75**CONFigure:BTOoth:ICFTolerance:ULIMit <UpperLimit>**

Defines the upper limit for the initial carrier frequency tolerance (ICFT).

**Parameters:**

<UpperLimit> numeric value  
 Range: -500000 to 500000  
 \*RST: 75000  
 Default unit: HZ

**Example:**

```
CALC:LIM:TRAC:CHEC ON
CONF:BTO:ICFT:ULIM 80000
```

**Manual operation:** See ["ICFT Upper / ICFT Lower"](#) on page 75

**CONFigure:BT0oth:IFDRift:LLIMit** <LowerLimit>

Defines the lower limit for the initial frequency drift of LE packets.

**Parameters:**

<LowerLimit> numeric value  
 Range: -500000 to 500000  
 \*RST: -150000  
 Default unit: HZ

**Example:**

```
CALC:LIM:TRAC:CHEC ON
CONF:BTO:IFDR:LLIM -23000
```

**Manual operation:** See ["Initial Freq Drift Upper / Initial Freq Drift Lower"](#) on page 79

**CONFigure:BT0oth:IFDRift:ULIMit** <UpperLimit>

Defines the upper limit for the initial frequency drift of LE packets.

**Parameters:**

<UpperLimit> numeric value  
 Range: -500000 to 500000  
 \*RST: -150000  
 Default unit: HZ

**Example:**

```
CALC:LIM:TRAC:CHEC ON
CONF:BTO:IFDR:ULIM 80000
```

**Manual operation:** See ["Initial Freq Drift Upper / Initial Freq Drift Lower"](#) on page 79

**CONFigure:BT0oth:MDRate:LLIMit** <LowerLimit>

Defines the lower limit for the maximum frequency drift rate in LE signals.

**Parameters:**

<LowerLimit> numeric value  
 Range: -500000 to 500000  
 \*RST: -20000  
 Default unit: HZ

**Example:**            `CALC:LIM:TRAC:CHEC ON`  
                           `CONF:BTO:MDR:LLIM -50000`

**Manual operation:** See "[Max Drift Rate Upper / Max Drift Rate Lower](#)" on page 76

#### **CONFigure:BTOoth:MDRate:ULIMit** <UpperLimit>

Defines the lower limit for the maximum frequency drift rate in LE signals.

##### **Parameters:**

<UpperLimit>            numeric value  
                               Range:        -500000 to 500000  
                               \*RST:        20000  
                               Default unit: HZ

**Example:**            `CALC:LIM:TRAC:CHEC ON`  
                           `CONF:BTO:MDR:ULIM 50000`

**Manual operation:** See "[Max Drift Rate Upper / Max Drift Rate Lower](#)" on page 76

#### **CONFigure:BTOoth:MODulation:F1Average:LLIMit** <LowerLimit>

Defines the lower limit for the average frequency offset for the first test sequence (00001111).

##### **Parameters:**

<LowerLimit>            numeric value  
                               The lower limit must be at least 1 kHz lower than the upper limit.  
                               Range:        -500000 to 500000  
                               \*RST:        115000  
                               Default unit: HZ

**Example:**            `CALC:LIM:TRAC:CHEC ON`  
                           `CONF:BTO:MOD:F1AV:LLIM 120000`

**Manual operation:** See "[Δf1 Avg Upper / Δf1 Avg Lower](#)" on page 75

#### **CONFigure:BTOoth:MODulation:F1Average:ULIMit** <UpperLimit>

Defines the upper limit for the average frequency offset for the first test sequence (00001111).

##### **Parameters:**

<UpperLimit>            numeric value  
                               Range:        -500000 to 500000  
                               \*RST:        175000  
                               Default unit: HZ

**Example:**            `CALC:LIM:TRAC:CHEC ON`  
                           `CONF:BTO:MOD:F1AV:ULIM 180000`

**Manual operation:** See "[Δf1 Avg Upper / Δf1 Avg Lower](#)" on page 75

**CONFigure:BT0oth:MODulation:F1Max:IRANge** <InRange>

Defines the limit for the maximum frequency offset for the first test sequence to be in range (for LE Coded).

**Parameters:**

<InRange> Allowed range for the maximum offset  
 Range: 0 to 1  
 \*RST: 0.999  
 Default unit: PCT

**Example:**

```
CALC:LIM:TRAC:CHEC ON
CONF:BT0:MOD:F1M:LLIM 0.8
```

**Manual operation:** See "[Δf1 Max In Range \(LE Coded\)](#)" on page 79

**CONFigure:BT0oth:MODulation:F1Max:LLIMit** <LowerLimit>

Defines the lower limit for the maximum frequency offset for the first test sequence (for LE coded).

**Parameters:**

<LowerLimit> numeric value  
 Range: -500000 to 500000  
 \*RST: 115000  
 Default unit: HZ

**Example:**

```
CALC:LIM:TRAC:CHEC ON
CONF:BT0:MOD:F1MAX:LLIM 8000
```

**Manual operation:** See "[Δf1 Max Lower \(LE Coded\)](#)" on page 78

**CONFigure:BT0oth:MODulation:FDIVision:LLIMit** <LowerLimit>

Defines the lower limit for the ratio of average f2 offset to average f1 offset.

**Parameters:**

<LowerLimit> Lower limit for the average offset ratio of f2 to f1.  
 Range: 0 to 1  
 \*RST: 0.8

**Example:**

```
CALC:LIM:TRAC:CHEC ON
CONF:BT0:MOD:FDIV:LLIM 0.78
```

**Manual operation:** See "[Δf2 Avg / Δf1 Avg Lower](#)" on page 75

**CONFigure:BT0oth:MODulation:F2Max:IRANge** <InRange>

Defines the limit for the maximum frequency offset for the second test sequence (01010101) to be in range.



**Parameters:**

<InRange> Allowed range for the maximum offset  
 Range: 0 to 1  
 \*RST: 0.999  
 Default unit: PCT

**Example:**

```
CALC:LIM:TRAC:CHEC ON
CONF:BTO:MOD:F2M:LLIM 0.8
```

**Manual operation:** See "[Δf2 Max In Range](#)" on page 75

**CONFigure:BTOoth:MODulation:F2Max:LLIMit <LowerLimit>**

Defines the lower limit for the maximum frequency offset for the second test sequence (01010101).

**Parameters:**

<LowerLimit> numeric value  
 Range: -500000 to 500000  
 \*RST: 115000  
 Default unit: HZ

**Example:**

```
CALC:LIM:TRAC:CHEC ON
CONF:BTO:MOD:F2MAX:LLIM 8000
```

**Manual operation:** See "[Δf2 Max Lower](#)" on page 75

**CONFigure:BTOoth:POWER:AVERage:LLIMit <LowerLimit>**

Defines the lower limit for the average output power.

**Parameters:**

<LowerLimit> Range: -200 to 100  
 \*RST: 0  
 Default unit: DBM

**Example:**

```
CALC:LIM:TRAC:CHEC ON
CONF:BTO:POW:AVER:LLIM 20
CONF:BTO:POW:AVER:ULIM 80
```

**Manual operation:** See "[Average Upper/ Average Lower](#)" on page 75

**CONFigure:BTOoth:POWER:AVERage:ULIMit <UpperLimit>**

Defines the upper limit for the average output power.

**Parameters:**

<UpperLimit> Range: -200 to 100  
 \*RST: 20  
 Default unit: DBM

**Example:**            `CALC:LIM:TRAC:CHEC ON`  
                          `CONF:BTO:POW:AVER:LLIM 20`  
                          `CONF:BTO:POW:AVER:ULIM 80`

**Manual operation:** See ["Average Upper/ Average Lower"](#) on page 75

#### **CONFigure:BT0oth:POWer:PEAK:RLIMit <RelativeLimit>**

The (calculated) limit for the peak output power relative to the average output power.

See [CONFigure:BT0oth:POWer:PEAK:ULIMit](#) and [CONFigure:BT0oth:POWer:AVERage:ULIMit](#).

#### **Parameters:**

<RelativeLimit>        numeric value  
                          Range:        -200 to 100  
                          \*RST:        3  
                          Default unit: DBM

**Example:**            `CALC:LIM:TRAC:CHEC ON`  
                          `CONF:BTO:POW:PEAK:ULIM?`  
                          `CONF:BTO:POW:AVER:ULIM?`  
                          `CONF:BTO:POW:PEAK:RLIM?`

**Manual operation:** See ["Relative Peak Upper \(Rel. to Avg Power\)"](#) on page 75

#### **CONFigure:BT0oth:POWer:PEAK:ULIMit <UpperLimit>**

Defines the upper limit for the peak output power.

#### **Parameters:**

<UpperLimit>            Range:        -200 to 100  
                          \*RST:        23  
                          Default unit: DBM

**Example:**            `CALC:LIM:TRAC:CHEC ON`  
                          `CONF:BTO:POW:PEAK:ULIM 25`

**Manual operation:** See ["Peak Upper"](#) on page 75

### **9.6.1.2 EDR signals**

- [Evaluation range](#)..... 162
- [Defining limit checks](#)..... 164

#### **Evaluation range**

<a href="#">CONFigure:BT0oth:RTPower:DAverage:START</a> .....	163
<a href="#">CONFigure:BT0oth:RTPower:DAverage:STOP</a> .....	163
<a href="#">CONFigure:BT0oth:RTPower:GAverage:START</a> .....	163
<a href="#">CONFigure:BT0oth:RTPower:GAverage:STOP</a> .....	163

**CONFigure:BT0oth:RTPower:DAverage:STARt** <Time>

Defines the start time of the power measurement for the DPSK-modulated part of the signal.

**Parameters:**

<Time> Percentage of the total measurement time  
 Range: 0 to 100  
 \*RST: 10  
 Default unit: PCT

**Example:** CONF:BT0:RTP:DAV:STAR 20

**Manual operation:** See "[DPSK Power Start / DPSK Power Stop](#)" on page 80

**CONFigure:BT0oth:RTPower:DAverage:STOP** <Time>

Defines the stop time of the power measurement for the DPSK-modulated part of the signal.

**Parameters:**

<Time> Percentage of the total measurement time  
 Range: 0 to 100  
 \*RST: 90  
 Default unit: PCT

**Example:** CONF:BT0:RTP:DAV:STOP 20

**Manual operation:** See "[DPSK Power Start / DPSK Power Stop](#)" on page 80

**CONFigure:BT0oth:RTPower:GAverage:STARt** <Percentage>

Defines the start time of the power measurement for the GFSK-modulated part of the signal.

**Parameters:**

<Percentage> Percentage of the total measurement time  
 Range: 0 to 100  
 \*RST: 10  
 Default unit: PCT

**Example:** CONF:BT0:RTP:GAV:STAR 20

**Manual operation:** See "[GFSK Power Start / GFSK Power Stop](#)" on page 80

**CONFigure:BT0oth:RTPower:GAverage:STOP** <Time>

Defines the stop time of the power measurement for the GFSK-modulated part of the signal.

**Parameters:**

<Time> Percentage of the total measurement time  
 Range: 0 to 100  
 \*RST: 90  
 Default unit: PCT

**Example:**

CONF: BTO: RTP: GAV: STOP 20

**Manual operation:** See ["GFSK Power Start / GFSK Power Stop"](#) on page 80

**Defining limit checks**

CONFigure: BTOoth: CFSTability: BFRequency: LLIMit.....	164
CONFigure: BTOoth: CFSTability: BFRequency: ULIMit.....	164
CONFigure: BTOoth: CFSTability: IFRequency: LLIMit.....	165
CONFigure: BTOoth: CFSTability: IFRequency: ULIMit.....	165
CONFigure: BTOoth: CFSTability: TFRequency: LLIMit.....	165
CONFigure: BTOoth: CFSTability: TFRequency: ULIMit.....	166
CONFigure: BTOoth: MODulation: DQ99: ULIMit.....	166
CONFigure: BTOoth: MODulation: P8PSk: ULIMit.....	166
CONFigure: BTOoth: MODulation: PDQPsk: ULIMit.....	167
CONFigure: BTOoth: MODulation: PS99: ULIMit.....	167
CONFigure: BTOoth: MODulation: R8PSk: ULIMit.....	167
CONFigure: BTOoth: MODulation: RDQPsk: ULIMit.....	168
CONFigure: BTOoth: RTPower: LLIMit.....	168
CONFigure: BTOoth: RTPower: ULIMit.....	168

**CONFigure: BTOoth: CFSTability: BFRequency: LLIMit <Limit>**

Defines the lower limit of the block frequency.

**Parameters:**

<Limit> numeric value  
 The lower limit must be at least 1 kHz lower than the upper limit.  
 Range: -1000000 to 1000000  
 \*RST: -10000  
 Default unit: HZ

**Example:**

CALC: LIM: TRAC: CHEC ON  
 CONF: BTO: CFST: BFR: LLIM -8000

**Manual operation:** See ["Block Freq Offset Upper / Lower"](#) on page 82

**CONFigure: BTOoth: CFSTability: BFRequency: ULIMit <Limit>**

Defines the upper limit of the initial frequency.

**Parameters:**

<Limit> numeric value  
 The upper limit must be at least 1 kHz higher than the lower limit.  
 Range: -1000000 to 1000000  
 \*RST: 10000  
 Default unit: HZ

**Example:**

```
CALC:LIM:TRAC:CHEC ON
CONF:BTO:CFST:BFR:ULIM 8000
```

**Manual operation:** See "[Block Freq Offset Upper / Lower](#)" on page 82

**CONFigure:BTOoth:CFSTability:IFrequency:LLIMit <Limit>**

Defines the lower limit of the initial frequency.

**Parameters:**

<Limit> numeric value  
 The lower limit must be at least 1 kHz lower than the upper limit.  
 Range: -1000000 to 1000000  
 \*RST: -75000  
 Default unit: HZ

**Example:**

```
CALC:LIM:TRAC:CHEC ON
CONF:BTO:CFST:IFR:LLIM -80000
```

**Manual operation:** See "[Initial Freq Offset Upper / Lower](#)" on page 81

**CONFigure:BTOoth:CFSTability:IFrequency:ULIMit <Limit>**

Defines the upper limit of the initial frequency.

**Parameters:**

<Limit> numeric value  
 The upper limit must be at least 1 kHz higher than the lower limit.  
 Range: -1000000 to 1000000  
 \*RST: 75000  
 Default unit: HZ

**Example:**

```
CALC:LIM:TRAC:CHEC ON
CONF:BTO:CFST:IFR:ULIM 80000
```

**Manual operation:** See "[Initial Freq Offset Upper / Lower](#)" on page 81

**CONFigure:BTOoth:CFSTability:TFrequency:LLIMit <Limit>**

Defines the lower limit of the total frequency offset.

**Parameters:**

<Limit> numeric value  
 The lower limit must be at least 1 kHz lower than the upper limit.  
 Range: -1000000 to 1000000  
 \*RST: -75000  
 Default unit: HZ

**Example:**

```
CALC:LIM:TRAC:CHEC ON
CONF:BTO:CFST:TFR:LLIM -80000
```

**Manual operation:** See ["Total Freq Offset Upper / Lower"](#) on page 82

**CONFigure:BTOoth:CFSTability:TFRrequency:ULIMit <Limit>**

Defines the upper limit of the total frequency offset.

**Parameters:**

<Limit> numeric value  
 The upper limit must be at least 1 kHz higher than the lower limit.  
 Range: -1000000 to 1000000  
 \*RST: 75000  
 Default unit: HZ

**Example:**

```
CALC:LIM:TRAC:CHEC ON
CONF:BTO:CFST:TFR:ULIM 8000
```

**Manual operation:** See ["Total Freq Offset Upper / Lower"](#) on page 82

**CONFigure:BTOoth:MODulation:DQ99:ULIMit <UpperLimit>**

Defines the upper limit for the 99-percentile DEVM for the DQPSK-modulated part of the signal.

**Parameters:**

<UpperLimit> numeric value  
 Range: 0 to 100  
 \*RST: 35  
 Default unit: PCT

**Example:**

```
CALC:LIM:TRAC:CHEC ON
CONF:BTO:MOD:DQ99:ULIM 20
```

**Manual operation:** See ["99% DQPSK / 8PSK"](#) on page 82

**CONFigure:BTOoth:MODulation:P8PSk:ULIMit <UpperLimit>**

Defines the upper limit for the peak DEVM for the 8PSK-modulated part of the signal.

**Parameters:**

&lt;UpperLimit&gt; numeric value

The lower limit must be at least 1 kHz lower than the upper limit.

Range: 0 to 100

\*RST: 25

Default unit: PCT

**Example:**

```
CALC:LIM:TRAC:CHEC ON
CONF:BTO:MOD:P8PS:ULIM 20
```

**Manual operation:** See "[Peak DQPSK / 8PSK](#)" on page 82**CONFigure:BTOoth:MODulation:PDQPSk:ULIMit** <UpperLimit>

Defines the upper limit for the peak DEVM for the DQPSK-modulated part of the signal.

**Parameters:**

&lt;UpperLimit&gt; numeric value

Range: 0 to 100

\*RST: 35

Default unit: PCT

**Example:**

```
CALC:LIM:TRAC:CHEC ON
CONF:BTO:MOD:PDQP:ULIM 20
```

**Manual operation:** See "[Peak DQPSK / 8PSK](#)" on page 82**CONFigure:BTOoth:MODulation:PS99:ULIMit** <UpperLimit>

Defines the upper limit for the 99-percentile DEVM for the 8PSK-modulated part of the signal.

**Parameters:**

&lt;UpperLimit&gt; numeric value

Range: 0 to 100

\*RST: 20

Default unit: PCT

**Example:**

```
CALC:LIM:TRAC:CHEC ON
CONF:BTO:MOD:PS99:ULIM 20
```

**Manual operation:** See "[99% DQPSK / 8PSK](#)" on page 82**CONFigure:BTOoth:MODulation:R8PSk:ULIMit** <UpperLimit>

Defines the upper limit for the RMS DEVM for the 8PSK-modulated part of the signal.

**Parameters:**

&lt;UpperLimit&gt; numeric value

Range: 0 to 100

\*RST: 13

Default unit: PCT

**Example:**            `CALC:LIM:TRAC:CHEC ON`  
                          `CONF:BTO:MOD:R8PS:ULIM 20`

**Manual operation:** See ["RMS DQPSK / 8PSK"](#) on page 82

#### **CONFigure:BTOoth:MODulation:RDQPsk:ULIMit** <UpperLimit>

Defines the upper limit for the RMS DEVM for the DQPSK-modulated part of the signal.

**Parameters:**

<UpperLimit>            numeric value  
                          Range:        0 to 100  
                          \*RST:        20  
                          Default unit: PCT

**Example:**            `CALC:LIM:TRAC:CHEC ON`  
                          `CONF:BTO:MOD:RDQP:ULIM 80`

**Manual operation:** See ["RMS DQPSK / 8PSK"](#) on page 82

#### **CONFigure:BTOoth:RTPower:LLIMit** <LowerLimit>

Defines the lower limit of the relative TX power.

**Parameters:**

<LowerLimit>            numeric value  
                          Range:        -100 to 100  
                          \*RST:        -4  
                          Default unit: DB

**Example:**            `CALC:LIM:TRAC:CHEC ON`  
                          `CONF:BTO:RTP:LLIM -80`

**Manual operation:** See ["Rel. Avg Power Upper / Lower"](#) on page 82

#### **CONFigure:BTOoth:RTPower:ULIMit** <UpperLimit>

Defines the upper limit of the relative TX power.

**Parameters:**

<UpperLimit>            numeric value  
                          Range:        -100 to 100  
                          \*RST:        1  
                          Default unit: DB

**Example:**            `CALC:LIM:TRAC:CHEC ON`  
                          `CONF:BTO:RTP:ULIM 80`

**Manual operation:** See ["Rel. Avg Power Upper / Lower"](#) on page 82



## 9.6.2 Analyzing in-band spurious emissions

- [Measurement settings](#)..... 169
- [Checking limits](#)..... 172
- [Configuring the Result Summary](#)..... 174

### 9.6.2.1 Measurement settings

Useful commands for configuring in-band spurious emissions measurements described elsewhere:

- [\[SENSe:\]CORREction:EGain:INPut\[:MAGNitude\]](#) on page 147

**Remote commands exclusive to configuring in-band spurious emissions measurements:**

<a href="#">[SENSe:]FREQuency:CENTer</a> .....	169
<a href="#">[SENSe:]FREQuency:CENTer:STEP</a> .....	169
<a href="#">[SENSe:]FREQuency:CENTer:STEP:LINK</a> .....	170
<a href="#">[SENSe:]SWEep:COUNT</a> .....	170
<a href="#">[SENSe:]SWEep:TIME</a> .....	171
<a href="#">CONFigure:BT0oth:IBSemissions:GEOGraphy</a> .....	171
<a href="#">CONFigure:BT0oth:IBSemissions:NCHannels</a> .....	171
<a href="#">CONFigure:BT0oth:LOAD</a> .....	171
<a href="#">CONFigure:BT0oth:STORe</a> .....	172

---

#### **[SENSe:]FREQuency:CENTer** <Frequency>

Defines the center frequency (frequency domain) or measuring frequency (time domain).

##### **Parameters:**

<Frequency>            Values depend on standard, see [Table 3-1](#).  
                                   Default unit: HZ

**Example:**                SENS:FREQ:CENT 1 GHz

**Manual operation:**    See "[Center Frequency](#)" on page 53

---

#### **[SENSe:]FREQuency:CENTer:STEP** <FrequencyStep>

Defines the center frequency step size.

You can increase or decrease the center frequency quickly in fixed steps using the SENS:FREQ UP AND SENS:FREQ DOWN commands, see [\[SENSe:\]FREQuency:CENTer](#) on page 169.

##### **Parameters:**

<FrequencyStep>         $f_{\max}$  is defined in the specifications document.  
                                   Range:        1 to fMAX  
                                   \*RST:        0.1 x span  
                                   Default unit: Hz

**Example:** //Set the center frequency to 110 MHz.  
 FREQ:CENT 100 MHz  
 FREQ:CENT:STEP 10 MHz  
 FREQ:CENT UP

**Manual operation:** See "[Frequency Stepsize](#)" on page 53

#### [SENSe:]FREQuency:CENTer:STEP:LINK <StepLink>

Couples and decouples the center frequency step size to the span.

##### Parameters:

<StepLink> SPAN | OFF

**SPAN**  
 Couples the step size to the span. Available for measurements in the frequency domain.

**OFF**  
 Decouples the step size.

\*RST: SPAN

**Example:** //Couple step size to span  
 FREQ:CENT:STEP:LINK SPAN

#### [SENSe:]SWEep:COUNT <SweepCount>

Defines the number of sweeps that the application uses to average traces.

In continuous sweep mode, the application calculates the moving average over the average count.

In single sweep mode, the application stops the measurement and calculates the average after the average count has been reached.

##### Parameters:

<SweepCount> If you set a sweep count of 0 or 1, the application performs one single sweep in single sweep mode.  
 In continuous sweep mode, if the average count is set to 0, a moving average over 10 sweeps is performed.

Range: 0 to 32767  
 \*RST: 0

**Example:** SWE:COUN 64  
 Sets the number of sweeps to 64.  
 INIT:CONT OFF  
 Switches to single sweep mode.  
 INIT;\*WAI  
 Starts a sweep and waits for its end.

**Manual operation:** See "[Sweep Count](#)" on page 69

**[SENSe:]SWEep:TIME <Time>**

Defines the signal capture time. It automatically decouples the time from any other settings.

The value depends on the used standard. See also [Chapter 6.2.1, "Measurement settings depending on standard"](#), on page 83.

**Parameters:**

<Time>                      Range:        400 us to 190 ms  
                                   Default unit: s

**Example:**                      SENSE:SWEep:TIME 0.1

**Manual operation:**    See "[Capture Time](#)" on page 86

**CONFigure:BT0oth:IBSemiissions:GEOGraphy <Geography>**

The specifications for in-band spurious emissions measurements differ for France and the rest of the world. Thus, in order to check the measurement results against limits for a particular standard, you must define the geographical location to consider. See also [Chapter 6.2.1, "Measurement settings depending on standard"](#), on page 83.

**Parameters:**

<Geography>                FRANce | OTHer

**Example:**                      CONF:BT0:IBS:GEOG OTH

**Manual operation:**    See "[Geography](#)" on page 85

**CONFigure:BT0oth:IBSemiissions:NCHannels <AdjChan>**

Defines the number of channels that are captured by the in-band spurious emissions measurement. The number must be an odd number.

**Parameters:**

<AdjChan>                    odd-numbered integer  
                                   The value depends on the used standard. See also [Chapter 6.2.1, "Measurement settings depending on standard"](#), on page 83.

**Example:**                      CONF:BT0:IBS:NCH 21  
                                   The R&S FSV3 Bluetooth measurement application measures 21 channels.

**Manual operation:**    See "[Number of Captured Channels](#)" on page 86

**CONFigure:BT0oth:LOAD <FilePath>**

Loads the measurement settings for the selected standard from a file with the defined name.

For an overview of predefined standards and settings, see [Chapter A, "Predefined standards and settings"](#), on page 205.

**Setting parameters:**

<FilePath> String containing the path and name of the file. Do not include the file extension.

**Example:** `CONF:BTO:LOAD 'BT_2-DH1'`

**Usage:** Setting only

**Manual operation:** See "[Load Predefined Settings](#)" on page 87

**CONFigure:BT0oth:STORe <FilePath>**

Saves the current measurement settings for a specific standard as a file with the defined name.

**Setting parameters:**

<FilePath> String containing the path and name of the file. Do not include the file extension.

**Example:** `CONF:BTO:STOR 'BT_LE_1M'`

**Usage:** Setting only

**Manual operation:** See "[Save Predefined Settings](#)" on page 87

**9.6.2.2 Checking limits**

Useful commands for checking limits described elsewhere:

- `CALCulate<n>:LIMit:TRACe<t>:CHECK` on page 154

**Remote commands exclusive to checking limits in in-band spurious emissions measurements:**

<code>CONFigure:BT0oth:IBSemiissions:FLIMit</code> .....	172
<code>CONFigure:BT0oth:IBSemiissions:L2MHz</code> .....	173
<code>CONFigure:BT0oth:IBSemiissions:L4MHz</code> .....	173
<code>CONFigure:BT0oth:IBSemiissions:L5MHz</code> .....	173
<code>CONFigure:BT0oth:IBSemiissions:NFAilures</code> .....	173
<code>CONFigure:BT0oth:IBSemiissions:NLIMit</code> .....	174
<code>CONFigure:BT0oth:IBSemiissions:RLIMit</code> .....	174

**CONFigure:BT0oth:IBSemiissions:FLIMit <Far Limit>**

Defines the minimum power difference between the TX channel and the second or further alternate channels.

**Parameters:**

<Far Limit> Range: -200 to +100  
 \*RST: -40  
 Default unit: DBM

**Example:** `CONF:BTO:IBS:FLIM -40 dBm`

**Manual operation:** See "[Far Limit](#)" on page 89

---

**CONFigure:BT0oth:IBSemissions:L2MHz <Limit>**

Defines the minimum power difference at a specified frequency offset from the transmit frequency.

This setting is only available for BT LE 1M and LE coded mode.

**Parameters:**

<Limit>                    Range:        -200 to +100  
                              \*RST:        -20  
                              Default unit: DBM

**Example:**                CONF:BT0:IBS:L2MHz -20 dBm

**Manual operation:**    See "[Limits for channels at frequency offsets](#)" on page 89

---

**CONFigure:BT0oth:IBSemissions:L4MHz <Limit>**

Defines the minimum power difference at a specified frequency offset from the transmit frequency.

This setting is only available for BT LE 2M mode.

**Parameters:**

<Limit>                    Range:        -200 to +100  
                              \*RST:        -20  
                              Default unit: DBM

**Example:**                CONF:BT0:IBS:L4MHz -20 dBm

**Manual operation:**    See "[Limits for channels at frequency offsets](#)" on page 89

---

**CONFigure:BT0oth:IBSemissions:L5MHz <Limit>**

Defines the minimum power difference at a specified frequency offset from the transmit frequency.

This setting is only available for BT LE 2M mode.

**Parameters:**

<Limit>                    Range:        -200 to +100  
                              \*RST:        -20  
                              Default unit: DBM

**Example:**                CONF:BT0:IBS:L4MHz -20 dBm

**Manual operation:**    See "[Limits for channels at frequency offsets](#)" on page 89

---

**CONFigure:BT0oth:IBSemissions:NFAilures <NofFailures>**

Defines the number of acceptable exceptions for the limit check to be considered passed.

**Parameters:**

<NofFailures> integer  
 Range: 0 to 80  
 \*RST: 0

**Example:**

CONF:BTO:IBS:NFA 4

The result of the Imit check is pass even if 4 limit check failures are detected.

**Manual operation:** See "[Allowed Exceptions](#)" on page 89

**CONFigure:BT0oth:IBSemissions:NLIMit** <Near Limit>

Defines the minimum power difference between the TX channel and the first alternate channel.

This setting is not available for BT LE mode.

**Parameters:**

<Near Limit> Range: -200 to +100  
 \*RST: -20  
 Default unit: DBM

**Example:**

CONF:BTO:IBS:NLIM -20 dBm

**Manual operation:** See "[Near Limit](#)" on page 89

**CONFigure:BT0oth:IBSemissions:RLIMit** <Relative Limit>

Defines the minimum power difference between the TX channel and the adjacent channel.

This setting is not available for BT LE mode.

**Parameters:**

<Relative Limit> Range: -200 to +100  
 \*RST: -26  
 Default unit: DBM

**Example:**

CONF:BTO:IBS:RLIM -26 dBm

**Manual operation:** See "[Relative Limit](#)" on page 89

**9.6.2.3 Configuring the Result Summary**

You can define which parameters are displayed in the "Result summary".

**DISPlay[:WINDow<n>]:TABLE:ITEM** <Items>, <State>

Defines which parameters are displayed in the "Result summary".

<b>Suffix:</b>	
<n>	1..n
<b>Parameters:</b>	
<Items>	CNABsolute   CNRelative   FREQuency   POWer   LIMit   DLIMit Individual result parameter For details on the parameters, see <a href="#">"Result Summary"</a> on page 41. <b>CNABsolute</b> Channel number absolute <b>CNRelative</b> Channel number relative <b>FREQuency</b> Frequency <b>POWer</b> Power <b>LIMit</b> Limit <b>DLIMit</b> Delta to limit
<State>	ON   OFF   0   1 <b>OFF   0</b> Removes the parameter <b>ON   1</b> Shows the parameter *RST: 1
<b>Example:</b>	DISP:WIND2:TABL:ITEM LIM,OFF Removes the limit result from the "Result Summary".
<b>Manual operation:</b>	See <a href="#">"Frequency/Power/Limit/Delta to Limit"</a> on page 90 See <a href="#">"Channel Number Abs/Rel"</a> on page 90

### 9.6.3 Working with markers

Markers help you analyze your measurement results by determining particular values in the diagram. Thus you can extract numeric values from a graphical display.

Manual configuration of markers is described in [Chapter 6.4, "Working with markers in the R&S FSV3 Bluetooth measurement application"](#), on page 92.

- [Individual marker settings](#)..... 176
- [General marker settings](#)..... 181
- [Marker search and positioning settings](#)..... 182

### 9.6.3.1 Individual marker settings

In VSA evaluations, up to 5 markers can be activated in each diagram at any time.

CALCulate<n>:MARKer<m>:AOFF.....	176
CALCulate<n>:MARKer<m>:LINK.....	176
CALCulate<n>:MARKer<ms>:LINK:TO:MARKer<md>.....	177
CALCulate<n>:MARKer<m>[:STATE].....	177
CALCulate<n>:MARKer<m>:TRACe.....	177
CALCulate<n>:MARKer<m>:X.....	178
CALCulate<n>:MARKer<m>:Y?.....	178
CALCulate<n>:DELTamarker<m>:AOFF.....	179
CALCulate<n>:DELTamarker<m>:LINK.....	179
CALCulate<n>:DELTamarker<ms>:LINK:TO:MARKer<md>.....	179
CALCulate<n>:DELTamarker<m>:MREFerence.....	180
CALCulate<n>:DELTamarker<m>:X.....	180
CALCulate<n>:DELTamarker<m>:Y?.....	180
CALCulate<n>:DELTamarker<m>[:STATE].....	181
CALCulate<n>:DELTamarker<m>:TRACe.....	181

---

#### CALCulate<n>:MARKer<m>:AOFF

Turns off all markers.

##### Suffix:

<n>                      Window

<m>                      Marker

##### Example:

CALC:MARK:AOFF  
Switches off all markers.

**Manual operation:** See "All Markers Off" on page 95

---

#### CALCulate<n>:MARKer<m>:LINK <MarkerCoupling>

With this command markers between several screens can be coupled, i.e. use the same x-value. All screens can be linked with the marker x-value scaled in symbols or time, except those showing the capture buffer. If several capture buffer measurements are visible, their markers are coupled, too.

##### Suffix:

<n>                      Window

<m>                      Marker

##### Setting parameters:

<MarkerCoupling> ON | OFF | 1 | 0  
\*RST:                0



**CALCulate<n>:MARKer<ms>:LINK:TO:MARKer<md> <State>**

Links the normal source marker <ms> to any active destination marker <md> (normal or delta marker).

If you change the horizontal position of marker <md>, marker <ms> changes its horizontal position to the same value.

**Suffix:**

<n>	<a href="#">Window</a>
<ms>	source marker, see <a href="#">Marker</a>
<md>	destination marker, see <a href="#">Marker</a>

**Parameters:**

<State>	ON   OFF   0   1
	<b>OFF   0</b>
	Switches the function off
	<b>ON   1</b>
	Switches the function on

**Example:** `CALC:MARK4:LINK:TO:MARK2 ON`  
Links marker 4 to marker 2.

**Manual operation:** See "[Linking to Another Marker](#)" on page 94

**CALCulate<n>:MARKer<m>[:STATe] <State>**

Turns markers on and off. If the corresponding marker number is currently active as a delta marker, it is turned into a normal marker.

**Suffix:**

<n>	<a href="#">Window</a>
<m>	<a href="#">Marker</a>

**Parameters:**

<State>	ON   OFF   0   1
	<b>OFF   0</b>
	Switches the function off
	<b>ON   1</b>
	Switches the function on

**Example:** `CALC:MARK3 ON`  
Switches on marker 3.

**Manual operation:** See "[Marker State](#)" on page 94  
See "[Marker Type](#)" on page 94  
See "[Select Marker](#)" on page 96

**CALCulate<n>:MARKer<m>:TRACe <Trace>**

Selects the trace the marker is positioned on.

Note that the corresponding trace must have a trace mode other than "Blank".

If necessary, the command activates the marker first.

**Suffix:**

<n> [Window](#)

<m> [Marker](#)

**Parameters:**

<Trace> **1 to 6**  
Trace number the marker is assigned to.

**Example:**

```
//Assign marker to trace 1
CALC:MARK3:TRAC 2
```

**Manual operation:** See ["Assigning the Marker to a Trace"](#) on page 95

**CALCulate<n>:MARKer<m>:X <Position>**

Moves a marker to a specific coordinate on the x-axis.

If necessary, the command activates the marker.

If the marker has been used as a delta marker, the command turns it into a normal marker.

**Suffix:**

<n> [Window](#)

<m> [Marker](#)

**Parameters:**

<Position> Numeric value that defines the marker position on the x-axis.  
The unit depends on the result display.  
Range: The range depends on the current x-axis range.  
Default unit: Hz

**Example:**

```
CALC:MARK2:X 1.7MHz
Positions marker 2 to frequency 1.7 MHz.
```

**Manual operation:** See ["Marker Table"](#) on page 38  
See ["Marker Position X-value"](#) on page 94

**CALCulate<n>:MARKer<m>:Y?**

Queries the result at the position of the specified marker.

**Suffix:**

<n> 1..n

<m> 1..n

**Return values:**

<Result> Default unit: DBM

**Usage:** Query only

**CALCulate<n>:DELTamarker<m>:AOFF**

Turns off *all* delta markers.

**Suffix:**

<n> [Window](#)

<m> irrelevant

**Example:**

CALC:DELT:AOFF

Turns off all delta markers.

**CALCulate<n>:DELTamarker<m>:LINK <State>**

Links delta marker <m> to marker 1.

If you change the horizontal position (x-value) of marker 1, delta marker <m> changes its horizontal position to the same value.

**Suffix:**

<n> [Window](#)

<m> [Marker](#)

**Parameters:**

<State> ON | OFF | 0 | 1

**OFF | 0**

Switches the function off

**ON | 1**

Switches the function on

**Example:**

CALC:DELT2:LINK ON

**Manual operation:** See "[Linking to Another Marker](#)" on page 94

**CALCulate<n>:DELTamarker<ms>:LINK:TO:MARKer<md> <State>**

Links the delta source marker <ms> to any active destination marker <md> (normal or delta marker).

**Suffix:**

<n> [Window](#)

<ms> source marker, see [Marker](#)

<md> destination marker, see [Marker](#)

**Parameters:**

<State> ON | OFF | 0 | 1

**OFF | 0**

Switches the function off

**ON | 1**

Switches the function on

**Example:** `CALC:DELT4:LINK:TO:MARK2 ON`  
Links the delta marker 4 to the marker 2.

**Manual operation:** See ["Linking to Another Marker"](#) on page 94

#### **CALCulate<n>:DELTamarker<m>:MREFerence <Reference>**

Selects a reference marker for a delta marker other than marker 1.

**Suffix:**

<n> [Window](#)

<m> [Marker](#)

**Parameters:**

<Reference>

**Example:** `CALC:DELT3:MREF 2`  
Specifies that the values of delta marker 3 are relative to marker 2.

**Manual operation:** See ["Reference Marker"](#) on page 94

#### **CALCulate<n>:DELTamarker<m>:X <Position>**

Moves a delta marker to a particular coordinate on the x-axis.

If necessary, the command activates the delta marker and positions a reference marker to the peak power.

**Suffix:**

<n> [Window](#)

<m> [Marker](#)

**Example:** `CALC:DELT:X?`  
Outputs the absolute x-value of delta marker 1.

**Manual operation:** See ["Marker Position X-value"](#) on page 94

#### **CALCulate<n>:DELTamarker<m>:Y?**

Queries the result at the position of the specified delta marker.

**Suffix:**

<n> 1..n

<m> 1..n

**Return values:**

<Result> Result at the position of the delta marker.  
The unit is variable and depends on the one you have currently set.

Default unit: DBM

**Usage:** Query only

**CALCulate<n>:DELTamarker<m>[:STATe] <State>**

Turns delta markers on and off.

If necessary, the command activates the delta marker first.

No suffix at DELTmarker turns on delta marker 1.

**Suffix:**

<n> [Window](#)

<m> [Marker](#)

**Parameters:**

<State> ON | OFF | 0 | 1

**OFF | 0**

Switches the function off

**ON | 1**

Switches the function on

**Example:**

CALC:DELT2 ON

Turns on delta marker 2.

**Manual operation:** See ["Marker State"](#) on page 94  
 See ["Marker Type"](#) on page 94  
 See ["Select Marker"](#) on page 96

**CALCulate<n>:DELTamarker<m>:TRACe <Trace>**

Selects the trace a delta marker is positioned on.

Note that the corresponding trace must have a trace mode other than "Blank".

If necessary, the command activates the marker first.

**Suffix:**

<n> [Window](#)

<m> [Marker](#)

**Parameters:**

<Trace> Trace number the marker is assigned to.

**Example:**

CALC:DELT2:TRAC 2

Positions delta marker 2 on trace 2.

**9.6.3.2 General marker settings****DISPlay[:WINDow<n>]:MINFo[:STATe] <State>**

Turns the marker information in all diagrams on and off.

**Suffix:**

&lt;n&gt; irrelevant

**Parameters:**

<State> **ON | 1**  
Displays the marker information in the diagrams.

**OFF | 0**  
Hides the marker information in the diagrams.

\*RST: 1

**Example:**

DISP:MINF OFF  
Hides the marker information.

**Manual operation:** See "[Marker Info](#)" on page 96

**DISPlay[:WINDow<n>]:MTABLE <DisplayMode>**

Turns the marker table on and off.

**Suffix:**

&lt;n&gt; irrelevant

**Parameters:**

<DisplayMode> **ON | 1**  
Turns on the marker table.

**OFF | 0**  
Turns off the marker table.

\*RST: AUTO

**Example:**

DISP:MTAB ON  
Activates the marker table.

**Manual operation:** See "[Marker Table Display](#)" on page 95

**9.6.3.3 Marker search and positioning settings**

Several functions are available to set the marker to a specific position very quickly and easily. In order to determine the required marker position, searches may be performed. The search results can be influenced by special settings.

Useful commands for positioning markers described elsewhere:

- [CALCulate<n>:MARKer<m>:TRACe](#) on page 177
- [CALCulate<n>:DELTamarker<m>:TRACe](#) on page 181

**Remote commands exclusive to positioning markers:**

<a href="#">CALCulate&lt;n&gt;:DELTamarker&lt;m&gt;:MAXimum:LEFT</a> .....	183
<a href="#">CALCulate&lt;n&gt;:DELTamarker&lt;m&gt;:MAXimum:NEXT</a> .....	183
<a href="#">CALCulate&lt;n&gt;:DELTamarker&lt;m&gt;:MAXimum[:PEAK]</a> .....	183
<a href="#">CALCulate&lt;n&gt;:DELTamarker&lt;m&gt;:MAXimum:RIGHT</a> .....	183
<a href="#">CALCulate&lt;n&gt;:DELTamarker&lt;m&gt;:MINimum:LEFT</a> .....	184
<a href="#">CALCulate&lt;n&gt;:DELTamarker&lt;m&gt;:MINimum:NEXT</a> .....	184

CALCulate<n>:DELTaMarker<m>:MINimum[:PEAK].....	184
CALCulate<n>:DELTaMarker<m>:MINimum:RIGHT.....	184
CALCulate<n>:MARKer<m>:MAXimum:LEFT.....	185
CALCulate<n>:MARKer<m>:MAXimum:NEXT.....	185
CALCulate<n>:MARKer<m>:MAXimum:RIGHT.....	185
CALCulate<n>:MARKer<m>:MAXimum[:PEAK].....	185
CALCulate<n>:MARKer<m>:MINimum:LEFT.....	186
CALCulate<n>:MARKer<m>:MINimum:NEXT.....	186
CALCulate<n>:MARKer<m>:MINimum:RIGHT.....	186
CALCulate<n>:MARKer<m>:MINimum[:PEAK].....	186

---

#### **CALCulate<n>:DELTaMarker<m>:MAXimum:LEFT**

Moves a delta marker to the next positive peak value.

The search includes only measurement values to the left of the current marker position.

**Suffix:**

<n>                    Window

<m>                    Marker

**Manual operation:**    See "Search Next Peak" on page 97

---

#### **CALCulate<n>:DELTaMarker<m>:MAXimum:NEXT**

Moves a marker to the next positive peak value.

**Suffix:**

<n>                    1..n  
                         Window

<m>                    1..n  
                         Marker

**Manual operation:**    See "Search Next Peak" on page 97

---

#### **CALCulate<n>:DELTaMarker<m>:MAXimum[:PEAK]**

Moves a delta marker to the highest level.

If the marker is not yet active, the command first activates the marker.

**Suffix:**

<n>                    Window

<m>                    Marker

**Manual operation:**    See "Peak Search" on page 97

---

#### **CALCulate<n>:DELTaMarker<m>:MAXimum:RIGHT**

Moves a delta marker to the next positive peak value on the trace.

The search includes only measurement values to the right of the current marker position.

**Suffix:**

<n> [Window](#)

<m> [Marker](#)

**Manual operation:** See "[Search Next Peak](#)" on page 97

---

**CALCulate<n>:DELTamarker<m>:MINimum:LEFT**

Moves a delta marker to the next minimum peak value.

The search includes only measurement values to the right of the current marker position.

**Suffix:**

<n> [Window](#)

<m> [Marker](#)

**Manual operation:** See "[Search Next Minimum](#)" on page 97

---

**CALCulate<n>:DELTamarker<m>:MINimum:NEXT**

Moves a marker to the next minimum peak value.

**Suffix:**

<n> [Window](#)

<m> [Marker](#)

**Manual operation:** See "[Search Next Minimum](#)" on page 97

---

**CALCulate<n>:DELTamarker<m>:MINimum[:PEAK]**

Moves a delta marker to the minimum level.

If the marker is not yet active, the command first activates the marker.

**Suffix:**

<n> [Window](#)

<m> [Marker](#)

**Manual operation:** See "[Search Minimum](#)" on page 97

---

**CALCulate<n>:DELTamarker<m>:MINimum:RIGHT**

Moves a delta marker to the next minimum peak value.

The search includes only measurement values to the right of the current marker position.



**Suffix:**<n> [Window](#)<m> [Marker](#)**Manual operation:** See "[Search Next Minimum](#)" on page 97

---

**CALCulate<n>:MARKer<m>:MAXimum:LEFT**

Moves a marker to the next positive peak.

The search includes only measurement values to the left of the current marker position.

**Suffix:**<n> [Window](#)<m> [Marker](#)**Manual operation:** See "[Search Next Peak](#)" on page 97

---

**CALCulate<n>:MARKer<m>:MAXimum:NEXT**

Moves a marker to the next positive peak.

**Suffix:**<n> [Window](#)<m> [Marker](#)**Manual operation:** See "[Search Next Peak](#)" on page 97

---

**CALCulate<n>:MARKer<m>:MAXimum:RIGHT**

Moves a marker to the next positive peak.

The search includes only measurement values to the right of the current marker position.

**Suffix:**<n> [Window](#)<m> [Marker](#)**Manual operation:** See "[Search Next Peak](#)" on page 97

---

**CALCulate<n>:MARKer<m>:MAXimum[:PEAK]**

Moves a marker to the highest level.

If the marker is not yet active, the command first activates the marker.

**Suffix:**<n> [Window](#)<m> [Marker](#)

**Manual operation:** See ["Peak Search"](#) on page 97

---

#### **CALCulate<n>:MARKer<m>:MINimum:LEFT**

Moves a marker to the next minimum peak value.

The search includes only measurement values to the right of the current marker position.

**Suffix:**

<n> [Window](#)

<m> [Marker](#)

**Manual operation:** See ["Search Next Minimum"](#) on page 97

---

#### **CALCulate<n>:MARKer<m>:MINimum:NEXT**

Moves a marker to the next minimum peak value.

**Suffix:**

<n> [Window](#)

<m> [Marker](#)

**Manual operation:** See ["Search Next Minimum"](#) on page 97

---

#### **CALCulate<n>:MARKer<m>:MINimum:RIGHT**

Moves a marker to the next minimum peak value.

The search includes only measurement values to the right of the current marker position.

**Suffix:**

<n> [Window](#)

<m> [Marker](#)

**Manual operation:** See ["Search Next Minimum"](#) on page 97

---

#### **CALCulate<n>:MARKer<m>:MINimum[:PEAK]**

Moves a marker to the minimum level.

If the marker is not yet active, the command first activates the marker.

**Suffix:**

<n> [Window](#)

<m> [Marker](#)

**Manual operation:** See ["Search Minimum"](#) on page 97

## 9.7 Configuring the result display

The commands required to configure the screen display in a remote environment are described here.

- [General window commands](#)..... 187
- [Working with windows in the display](#)..... 188

### 9.7.1 General window commands

The following commands are required to configure general window layout, independent of the application.

<a href="#">DISPlay:FORMat</a> .....	187
<a href="#">DISPlay[:WINDow&lt;n&gt;]:SIZE</a> .....	187

---

#### DISPlay:FORMat <Format>

Determines which tab is displayed.

##### Parameters:

<Format>

##### SPLit

Displays the MultiView tab with an overview of all active channels

##### SINGle

Displays the measurement channel that was previously focused.

\*RST: SING

##### Example:

DISP:FORM SPL

---

#### DISPlay[:WINDow<n>]:SIZE <Size>

Maximizes the size of the selected result display window *temporarily*. To change the size of several windows on the screen permanently, use the `LAY:SPL` command (see [LAYout:SPLitter](#) on page 191).

##### Suffix:

<n>

Window

##### Parameters:

<Size>

##### LARGE

Maximizes the selected window to full screen. Other windows are still active in the background.

##### SMALI

Reduces the size of the selected window to its original size. If more than one measurement window was displayed originally, these are visible again.

\*RST: SMALI

##### Example:

DISP:WIND2:SIZE LARG

## 9.7.2 Working with windows in the display

The following commands are required to change the evaluation type and rearrange the screen layout for a channel as you do using the SmartGrid in manual operation. Since the available evaluation types depend on the selected application, some parameters for the following commands also depend on the selected channel.

Note that the suffix <n> always refers to the window *in the currently selected channel*.

LAYout:ADD[:WINDow]?	188
LAYout:CATalog[:WINDow]?	189
LAYout:IDENtify[:WINDow]?	190
LAYout:MOVE[:WINDow]	190
LAYout:REMOve[:WINDow]	190
LAYout:REPLace[:WINDow]	191
LAYout:SPLitter	191
LAYout:WINDow<n>:ADD?	193
LAYout:WINDow<n>:IDENtify?	193
LAYout:WINDow<n>:REMOve	194
LAYout:WINDow<n>:REPLace	194

---

### LAYout:ADD[:WINDow]? <WindowName>, <Direction>, <WindowType>

Adds a window to the display in the active channel.

Is always used as a query so that you immediately obtain the name of the new window as a result.

To replace an existing window, use the `LAYout:REPLace[:WINDow]` command.

#### Query parameters:

<WindowName>	String containing the name of the existing window the new window is inserted next to. By default, the name of a window is the same as its index. To determine the name and index of all active windows, use the <code>LAYout:CATalog[:WINDow]?</code> query.
<Direction>	LEFT   RIGHT   ABOVE   BELOW Direction the new window is added relative to the existing window.
<WindowType>	text value Type of result display (evaluation method) you want to add. See the table below for available parameter values.

#### Return values:

<NewWindowName>	When adding a new window, the command returns its name (by default the same as its number) as a result.
-----------------	---

**Usage:** Query only

**Manual operation:** See "RF Envelope" on page 34  
 See "RF Spectrum" on page 34  
 See "Result Summary" on page 35  
 See "Header Info" on page 38  
 See "Marker Table" on page 38  
 See "Demod waveform (not for EDR)" on page 39  
 See "Constellation (EDR only)" on page 39  
 See "Symbols (EDR only)" on page 40  
 See "ACP / In-band Spurious Emissions" on page 40  
 See "Result Summary" on page 41

**Table 9-3: <WindowType> parameter values for Bluetooth application**

Parameter value	Window type
CONS	Constellation
DWAV	Demod Waveform
HDR	Header Info
MTAB	Marker Table
RSUM	Result Summary
RFEN	RF Envelope
RFSP	RF Spectrum
SPEC	ACP/ In-band Spurious Emissions
SYMB	Symbols

### LAYout:CATalog[:WINDow]?

Queries the name and index of all active windows in the active channel from top left to bottom right. The result is a comma-separated list of values for each window, with the syntax:

<WindowName\_1>,<WindowIndex\_1>..<WindowName\_n>,<WindowIndex\_n>

**Return values:**

<WindowName>      string  
 Name of the window.  
 In the default state, the name of the window is its index.

<WindowIndex>    **numeric value**  
 Index of the window.

**Example:**

LAY:CAT?

Result:

'2',2,'1',1

Two windows are displayed, named '2' (at the top or left), and '1' (at the bottom or right).

**Usage:**            Query only

---

**LAYout:IDENTify[:WINDow]?** <WindowName>

Queries the **index** of a particular display window in the active channel.

**Note:** to query the **name** of a particular window, use the `LAYout:WINDow<n>:IDENTify?` query.

**Query parameters:**

<WindowName> String containing the name of a window.

**Return values:**

<WindowIndex> Index number of the window.

**Example:**

```
LAY:IDEN:WIND? '2'
```

Queries the index of the result display named '2'.

Response:

```
2
```

**Usage:** Query only

---

**LAYout:MOVE[:WINDow]** <WindowName>, <WindowName>, <Direction>**Setting parameters:**

<WindowName> String containing the name of an existing window that is to be moved.

By default, the name of a window is the same as its index. To determine the name and index of all active windows in the active channel, use the `LAYout:CATalog[:WINDow]?` query.

<WindowName> String containing the name of an existing window the selected window is placed next to or replaces.

By default, the name of a window is the same as its index. To determine the name and index of all active windows in the active channel, use the `LAYout:CATalog[:WINDow]?` query.

<Direction> LEFT | RIGHT | ABOVE | BELOW | REPLACE

Destination the selected window is moved to, relative to the reference window.

**Example:**

```
LAY:MOVE '4', '1', LEFT
```

Moves the window named '4' to the left of window 1.

**Example:**

```
LAY:MOVE '1', '3', REPL
```

Replaces the window named '3' by window 1. Window 3 is deleted.

**Usage:** Setting only

---

**LAYout:REMOve[:WINDow]** <WindowName>

Removes a window from the display in the active channel.

**Setting parameters:**

<WindowName> String containing the name of the window. In the default state, the name of the window is its index.

**Example:**

```
LAY:REM '2'
```

Removes the result display in the window named '2'.

**Usage:**

Setting only

**LAYout:REPLace[:WINDow]** <WindowName>, <WindowType>

Replaces the window type (for example from "Diagram" to "Result Summary") of an already existing window in the active channel while keeping its position, index and window name.

To add a new window, use the [LAYout:ADD\[:WINDow\]?](#) command.

**Setting parameters:**

<WindowName> String containing the name of the existing window.  
By default, the name of a window is the same as its index. To determine the name and index of all active windows in the active channel, use the [LAYout:CATalog\[:WINDow\]?](#) query.

<WindowType> Type of result display you want to use in the existing window.  
See [LAYout:ADD\[:WINDow\]?](#) on page 188 for a list of available window types.

**Example:**

```
LAY:REPL:WIND '1',MTAB
```

Replaces the result display in window 1 with a marker table.

**Usage:**

Setting only

**LAYout:SPLitter** <Index1>, <Index2>, <Position>

Changes the position of a splitter and thus controls the size of the windows on each side of the splitter.

Note that windows must have a certain minimum size. If the position you define conflicts with the minimum size of any of the affected windows, the command does not work, but does not return an error.

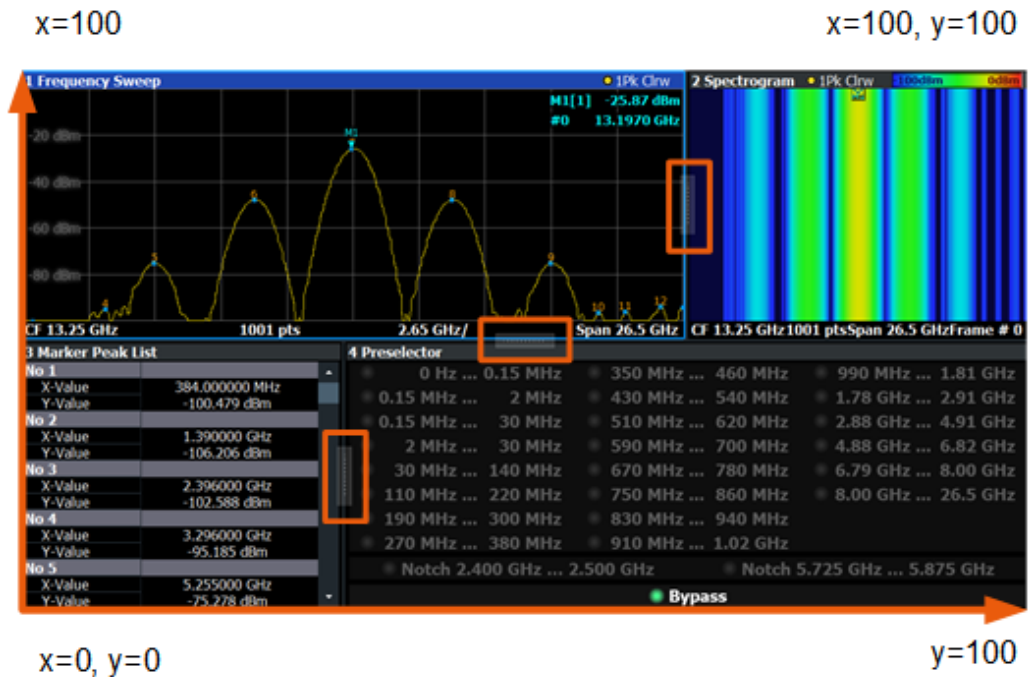

Figure 9-1: SmartGrid coordinates for remote control of the splitters

#### Setting parameters:

- <Index1> The index of one window the splitter controls.
- <Index2> The index of a window on the other side of the splitter.
- <Position> New vertical or horizontal position of the splitter as a fraction of the screen area (without channel and status bar and softkey menu).  
The point of origin (x = 0, y = 0) is in the lower left corner of the screen. The end point (x = 100, y = 100) is in the upper right corner of the screen. (See Figure 9-1.)  
The direction in which the splitter is moved depends on the screen layout. If the windows are positioned horizontally, the splitter also moves horizontally. If the windows are positioned vertically, the splitter also moves vertically.

Range: 0 to 100

#### Example:

LAY:SPL 1,3,50

Moves the splitter between window 1 ("Frequency Sweep") and 3 ("Marker Table") to the center (50%) of the screen, i.e. in the figure above, to the left.



**Example:** `LAY:SPL 1,4,70`  
 Moves the splitter between window 1 ('Frequency Sweep') and 3 ('Marker Peak List') towards the top (70%) of the screen. The following commands have the exact same effect, as any combination of windows above and below the splitter moves the splitter vertically.

`LAY:SPL 3,2,70`  
`LAY:SPL 4,1,70`  
`LAY:SPL 2,1,70`

**Usage:** Setting only

#### **LAYout:WINDow<n>:ADD? <Direction>,<WindowType>**

Adds a measurement window to the display. Note that with this command, the suffix <n> determines the existing window next to which the new window is added. Unlike [LAYout:ADD\[:WINDow\]?](#), for which the existing window is defined by a parameter.

To replace an existing window, use the [LAYout:WINDow<n>:REPLace](#) command.

Is always used as a query so that you immediately obtain the name of the new window as a result.

#### **Suffix:**

<n> [Window](#)

#### **Query parameters:**

<Direction> LEFT | RIGHT | ABOVE | BELOW

<WindowType> Type of measurement window you want to add.  
 See [LAYout:ADD\[:WINDow\]?](#) on page 188 for a list of available window types.

#### **Return values:**

<NewWindowName> When adding a new window, the command returns its name (by default the same as its number) as a result.

**Example:** `LAY:WIND1:ADD? LEFT,MTAB`  
**Result:**  
 '2'  
 Adds a new window named '2' with a marker table to the left of window 1.

**Usage:** Query only

#### **LAYout:WINDow<n>:IDENTify?**

Queries the **name** of a particular display window (indicated by the <n> suffix) in the active channel.

**Note:** to query the **index** of a particular window, use the [LAYout:IDENTify\[:WINDow\]?](#) command.

<b>Suffix:</b>	
<n>	Window
<b>Return values:</b>	
<WindowName>	String containing the name of a window. In the default state, the name of the window is its index.
<b>Example:</b>	LAY:WIND2:IDEN? Queries the name of the result display in window 2. Response: '2'
<b>Usage:</b>	Query only

---

#### LAYout:WINDow<n>:REMOve

Removes the window specified by the suffix <n> from the display in the active channel.  
The result of this command is identical to the `LAYout:REMOve[:WINDow]` command.

<b>Suffix:</b>	
<n>	Window
<b>Example:</b>	LAY:WIND2:REM Removes the result display in window 2.
<b>Usage:</b>	Event

---

#### LAYout:WINDow<n>:REPLace <WindowType>

Changes the window type of an existing window (specified by the suffix <n>) in the active channel.

The effect of this command is identical to the `LAYout:REPLace[:WINDow]` command.

To add a new window, use the `LAYout:WINDow<n>:ADD?` command.

<b>Suffix:</b>	
<n>	Window
<b>Setting parameters:</b>	
<WindowType>	Type of measurement window you want to replace another one with. See <code>LAYout:ADD[:WINDow]?</code> on page 188 for a list of available window types.
<b>Example:</b>	LAY:WIND2:REPL MTAB Replaces the result display in window 2 with a marker table.
<b>Usage:</b>	Setting only

## 9.8 Retrieving results

In order to retrieve the trace and marker results in a remote environment, use the following commands:

Useful commands for retrieving results described elsewhere:

- `CALCulate<n>:MARKer<m>:Y?` on page 178

### Remote commands exclusive to retrieving results:

<code>CALCulate&lt;n&gt;:LIMit:FAIL?</code> .....	195
<code>FORMat:DEXPort:DSEParator</code> .....	195
<code>FORMat:DEXPort:HEADer</code> .....	196
<code>MMEMory:STORe:BT:MEAS</code> .....	196
<code>MMEMory:STORe&lt;n&gt;:TRACe</code> .....	196
<code>TRACe&lt;n&gt;[:DATA]?</code> .....	197

---

### `CALCulate<n>:LIMit:FAIL?`

Queries the results of the limits check.

#### Suffix:

<n> 1..n

#### Example:

```
CALCulate1:LIMit1:FAIL?
//Result: 0
//Limit check passed.
```

#### Usage:

Query only

#### Manual operation:

See "[ACP / In-band Spurious Emissions](#)" on page 40  
See "[Result Summary](#)" on page 41

---

### `FORMat:DEXPort:DSEParator <Separator>`

Selects the decimal separator for data exported in ASCII format.

#### Parameters:

<Separator> POINT | COMMa

#### COMMa

Uses a comma as decimal separator, e.g. *4,05*.

#### POINT

Uses a point as decimal separator, e.g. *4.05*.

\*RST: \*RST has no effect on the decimal separator.  
Default is POINT.

#### Example:

```
FORM:DEXP:DSEP POIN
Sets the decimal point as separator.
```

#### Manual operation:

See "[Decimal Separator](#)" on page 92

**FORMat:DEXPort:HEADer** <State>

If enabled, additional instrument and measurement settings are included in the header of the export file for result data. If disabled, only the pure result data from the selected traces and tables is exported.

**Parameters:**

<State> ON | OFF | 0 | 1  
\*RST: 1

**Manual operation:** See ["Include Instrument & Measurement Settings"](#) on page 91

**MMEMory:STORe:BT:MEAS** <FileName>

Exports trace data for all active traces in all active windows to a file in .csv format.

**Tip:** To store trace data for an individual trace or an individual window, use [MMEMory:STORe<n>:TRACe](#) on page 196.

**Setting parameters:**

<FileName> String containing the path and name of the file.

**Example:** MMEM:STOR:BT:MEAS 'C:\MyResults.csv'

**Usage:** Setting only

**MMEMory:STORe<n>:TRACe** <Trace>, <FileName>

Exports the selected trace data to a file in ASCII format. Define the decimal separator (decimal point or comma) for floating-point numerals contained in the file using [FORMat:DEXPort:DSEParator](#).

**Tip:** to store trace data for all active traces in all active windows to a file in .csv format, use [MMEMory:STORe:BT:MEAS](#) on page 196.

**Suffix:**

<n> 1..n  
[Window](#)

**Setting parameters:**

<Trace> Number of the trace you want to save.  
Note that the available number of traces depends on the selected result display. The value "0" exports all traces in a window.

Range: 0 to 4

<FileName> String containing the path and file name.

**Example:**

```
//Export all traces in all windows to the specified file.
FORM:DEXP:TRAC ALL
M MEM:STOR:TRAC 0, 'C:\TraceResults'
//Export all traces in window 2 to the specified file.
FORM:DEXP:TRAC SING
M MEM:STOR2:TRAC 0, 'C:\TraceResults'
//Export the second trace in window 2 to the specified file.
M MEM:STOR2:TRAC 2, 'C:\TraceResults'
```

**Usage:** Setting only

**Manual operation:** See ["Selecting data to export"](#) on page 91  
See ["Export Trace to ASCII File"](#) on page 92

### TRACe<n>[:DATA]? <Trace>

Returns the measurement results of the selected window and trace.

For details on the values see [Chapter 4, "Measurements and result displays"](#), on page 33.

**Suffix:**

<n> 1..n

**Query parameters:**

<Trace> TRACe1 | TRACe2 | TRACe3 | TRACe4 | CTABLE

**TRACe1 | TRACe2 | TRACe3 | TRACe4**

Returns the trace data.

For the result summary, returns all basic parameters in the same order as they appear on the screen. Values depend on the used standard, see tables below.

**CTABLE**

For in-band spurious emissions result summary only. Returns only the visible parameters as defined by [DISPlay\[: WINDow<n>\]: TABLE: ITEM](#) on page 174.

**Usage:** Query only

**Manual operation:** See ["RF Envelope"](#) on page 34  
See ["RF Spectrum"](#) on page 34  
See ["Result Summary"](#) on page 35  
See ["Header Info"](#) on page 38  
See ["Demod waveform \(not for EDR\)"](#) on page 39  
See ["Constellation \(EDR only\)"](#) on page 39  
See ["Symbols \(EDR only\)"](#) on page 40  
See ["ACP / In-band Spurious Emissions"](#) on page 40  
See ["Result Summary"](#) on page 41

**Table 9-4: Return values for the modulation characteristics result summary for BR signals**

```

<PacketType>,<PacketLength>,
<OutputPowerPeak_Current>,<OPP_Max>,<OPP_Min>,<OPP_Avg>,<OPP_LL>,<OPP_UL>,
<OutputPowerAvg_Current>,<OPA_Max>,<OPA_Min>,<OPA_Avg>,<OPA_LL>,<OPA_UL>,
<OutputPowerRel_Current>,<OPR_Max>,<OPR_Min>,<OPR_Avg>,
<df1Max_Current>,<df1Max_Max>,<df1Max_Min>,<df1Max_Avg>,
<df1Min_Current>,<df1Min_Max>,<df1Min_Min>,<df1Min_Avg>,
<df1Avg_Current>,<df1Avg_Max>,<df1Avg_Min>,<df1Avg_Avg>,<df1Avg_LL>,<df1Avg_UL>,
<df2Max_Current>,<df2Max_Max>,<df2Max_Min>,<df2Max_Avg>,<df2Max_LL>,<df2Max_UL>,
<df2Min_Current>,<df2Min_Max>,<df2Min_Min>,<df2Min_Avg>,
<df2Avg_Current>,<df2Avg_Max>,<df2Avg_Min>,<df2Avg_Avg>,
<df2MaxInRange_Current>,<df2MaxR_Max>,<df2MaxR_Min>,<df2MaxR_Avg>,<df2MaxR_LL>,<df2MaxR_UL>,
<df2/df1_Current>,<df2/df1_Max>,<df2/df1_Min>,<df2/df1_Avg>,<df2/df1_LL>,<df2/df1_UL>,
<FreqDrift_Current>,<FD_Max>,<FD_Min>,<FD_Avg>,
<MaxDriftRatePerPacket_Current>,<MDR_Max>,<MDR_Min>,<MDR_Avg>,
<ICFT_Current>,<ICFT_Max>,<ICFT_Min>,<ICFT_Avg>,<ICFT_LL>,<ICFT_UL>

```

**Table 9-5: Return values for the modulation characteristics result summary for EDR signals**

```

<PacketType>,<PacketLength>,<PacketTested>,<PacketPassed>,<BER>,
<GFSKAvgPower_Current>,<GFSKAP_Max>,<GFSKAP_Min>,<GFSKAP_Avg>,
<DPSKAvgPower>,<DPSKAP_Max>,<DPSKAP_Min>,<DPSKAP_Avg>,
<RelAvgPower>,<RAP_Max>,<RAP_Min>,<RAP_Avg>,<RAP_LL>,<RAP_UL>,
<RMSDEVMQPSK>,<RMSQ_Max>,<RMSQ_Min>,<RMSQ_Avg>,<RMSQ_LL>,<RMSQ_UL>,
<PeakDEVMQPSK>,<PQ_Max>,<PQ_Min>,<PQ_Avg>,<PQ_LL>,<PQ_UL>,
<99%DEVMQPSK>,<99Q_Max>,<99Q_Min>,<99Q_Avg>,<99Q_LL>,<99Q_UL>,
<RMSDEVM8PSK>,<RMS8_Max>,<RMS8_Min>,<RMS8_Avg>,<RMS8_LL>,<RMS8_UL>,
<PeakDEVM8PSK>,<P8_Max>,<P8_Min>,<P8_Avg>,<P8_LL>,<P8_UL>,
<99%DEVM8PSK>,<998_Max>,<998_Min>,<998_Avg>,<998_LL>,<998_UL>,
<InitialFrequencyOffset>,<IFO_Max>,<IFO_Min>,<IFO_Avg>,<IFO_LL>,<IFO_UL>,
<BlockFrequencyOffset>,<BFO_Max>,<BFO_Min>,<BFO_Avg>,<BFO_LL>,<BFO_UL>,
<TotalFrequencyOffset>,<TFO_Max>,<TFO_Min>,<TFO_Avg>,<TFO_LL>,<TFO_UL>,

```

**Table 9-6: Return values for the modulation characteristics result summary for LE signals**

```

<PacketType>,<PacketLength>,
<OutputPowerPeak_Current>,<OPP_Max>,<OPP_Min>,<OPP_Avg>,
<OutputPowerAvg_Current>,<OPA_Max>,<OPA_Min>,<OPA_Avg>,<OPA_LL>,<OPA_UL>,
<OutputPowerRel_Current>,<OPR_Max>,<OPR_Min>,<OPR_Avg>,<OPR_LL>,<OPR_UL>,
<df1Max_Current>,<df1Max_Max>,<df1Max_Min>,<df1Max_Avg>,
<df1Min_Current>,<df1Min_Max>,<df1Min_Min>,<df1Min_Avg>,
<df1Avg_Current>,<df1Avg_Max>,<df1Avg_Min>,<df1Avg_Avg>,<df1Avg_LL>,<df1Avg_UL>,
<df2Max_Current>,<df2Max_Max>,<df2Max_Min>,<df2Max_Avg>,<df2Max_LL>,<df2Max_UL>,
<df2Min_Current>,<df2Min_Max>,<df2Min_Min>,<df2Min_Avg>,
<df2Avg_Current>,<df2Avg_Max>,<df2Avg_Min>,<df2Avg_Avg>,
<df2MaxInRange_Current>,<df2MaxR_Max>,<df2MaxR_Min>,<df2MaxR_Avg>,<df2MaxR_LL>,<df2MaxR_UL>,
<df2/df1_Current>,<df2/df1_Max>,<df2/df1_Min>,<df2/df1_Avg>,<df2/df1_LL>,<df2/df1_UL>,
<FreqDrift_Current>,<FD_Max>,<FD_Min>,<FD_Avg>,<FD_LL>,<FD_UL>,
<MaxDriftRatePerPacket_Current>,<MDR_Max>,<MDR_Min>,<MDR_Avg>,<MDR_LL>,<MDR_UL>,
<FreqOff_Current>,<FO_Max>,<FO_Min>,<FO_Avg>,<FO_LL>,<FO_UL>,
<ICFT_Current>,<ICFT_Max>,<ICFT_Min>,<ICFT_Avg>,<ICFT_LL>,<ICFT_UL>

```

**Table 9-7: Return values for the in-band spurious emissions result summary (TRACe1)**

```

<TxChannelPower>,<TXChannelFrequency>,<NumberOfExceptions>,<AdjacentChannelPowerLower>,
<AdjacentChannelPowerUpper>
//EDR only -----
<GuardPosition>,<MeasTime>,
//-----
<ChannelNumberChannel0>,<ChannelFrequencyChannel0>,<PowerChannel0>,<LimitChannel0>,
<LimitCheckResult0>
...
<ChannelNumberChannel178>,<ChannelFrequencyChannel178>,<PowerChannel178>,<LimitChannel178>,
<LimitCheckResult178>

```

**Table 9-8: Return values for the in-band spurious emissions result summary (CTABle)**

```

//Channel abs 0 or Channel rel -40
<ChannelNumberChannelFirst>,<ChannelFrequencyChannelFirst>,<PowerChannelFirst>,
<LimitChannelFirst>,<LimitCheckResultFirst>,<DeltaToLimitFirst>
...
//Channel abs 78 or Channel rel +40
<ChannelNumberChannelLast>,<ChannelFrequencyChannelLast>,<PowerChannelLast>,<LimitChannelLast>,
<LimitCheckResultLast>,<DeltaToLimitLast>

```

## 9.9 Deprecated commands

The following commands are provided for compatibility to other signal analyzers only. For new remote control programs, use the specified alternative commands.

[SENSe:]DDEMod:SEARCh:PULSe:STATe.....	200
[SENSe:]DDEMod:SEARCh:PULSe:OFFSet.....	200
[SENSe:]DDEMod:SEARCh:SYNC:LAP.....	200
[SENSe:]DDEMod:SEARCh:SYNC:LAP:AUTO.....	200
[SENSe:]DDEMod:SEARCh:SYNC:OFFSet.....	201
[SENSe:]DDEMod:SEARCh:SYNC:STATe.....	201
[SENSe:]DDEMod:SEARCh:SYNC:UAP.....	201
[SENSe:]DDEMod:SEARCh:SYNC:UAP:AUTO.....	201

---

### [SENSe:]DDEMod:SEARCh:PULSe:STATe <State>

Enables or disables the search for a signal burst based on the measured power.

Note that this command is maintained for compatibility reasons only. For new remote control programs, use `CONFigure:BT0oth:SEARCh:PULSe:STATe` on page 145.

#### Parameters:

<State>                    ON | OFF | 0 | 1  
**OFF | 0**  
 Switches the function off  
**ON | 1**  
 Switches the function on  
 \*RST:                    1

**Manual operation:**    See "Find Burst" on page 66

---

### [SENSe:]DDEMod:SEARCh:PULSe:OFFSet <Offset>

#### Parameters:

<Offset>

---

### [SENSe:]DDEMod:SEARCh:SYNC:LAP <LAP>

Sets or queries the lower address part of the Bluetooth device address (LAP, the 24 least significant bits). The LAP determines the sync word used for sync search.

Note that this command is maintained for compatibility reasons only. For new remote control programs, use `CONFigure:BT0oth:SEARCh:SYNC:LAP` on page 145.

#### Parameters:

<LAP>                    Hexadecimal number  
 Range:                    #H000000h to #HFFFFFFh  
 \*RST:                    #H128

**Example:**                    `SENSe:DDEMod:SEARCh:SYNC:LAP #H128`

---

### [SENSe:]DDEMod:SEARCh:SYNC:LAP:AUTO <Mode>

Defines how the LAP is determined.



Note that this command is maintained for compatibility reasons only. For new remote control programs, use [CONFigure:BT0oth:SEARCh:SYNC:LAP:AUTO](#) on page 145.

**Parameters:**

<Mode> ON | OFF | 0 | 1  
**OFF | 0**  
 Define the LAP manually using [CONFigure:BT0oth:SEARCh:SYNC:LAP](#) on page 145  
**ON | 1**  
 The R&S FSV3 Bluetooth measurement application determines the LAP automatically  
 \*RST: 0

**[SENSe:]DDEMod:SEARCh:SYNC:OFFSet <Offset>**

**Parameters:**

<Offset>

**[SENSe:]DDEMod:SEARCh:SYNC:STATe <State>**

Enables or disables the search for the sync word.

Note that this command is maintained for compatibility reasons only. For new remote control programs, use [CONFigure:BT0oth:SEARCh:SYNC:STATe](#) on page 146.

**Parameters:**

<State> ON | OFF | 0 | 1  
**OFF | 0**  
 Switches the function off  
**ON | 1**  
 Switches the function on  
 \*RST: 1

**Manual operation:** See "[Find Sync](#)" on page 65

**[SENSe:]DDEMod:SEARCh:SYNC:UAP <UAP>**

Defines the UAP.

Note that this command is maintained for compatibility reasons only. For new remote control programs, use [CONFigure:BT0oth:SEARCh:SYNC:UAP](#) on page 146.

**Parameters:**

<UAP> numeric value in hexadecimal format

**[SENSe:]DDEMod:SEARCh:SYNC:UAP:AUTO <State>**

Defines how the UAP is determined.

Note that this command is maintained for compatibility reasons only. For new remote control programs, use `CONFigure:BT0oth:SEARCh:SYNC:UAP:AUTO` on page 146.

**Parameters:**

<State>                    ON | OFF | 0 | 1  
                               **OFF | 0**  
                               Define the UAP manually using `CONFigure:BT0oth:SEARCh:SYNC:UAP` on page 146  
                               **ON | 1**  
                               The R&S FSV3 Bluetooth measurement application determines the UAP automatically  
 \*RST:                    0

## 9.10 Programming examples: Measuring Bluetooth BR/EDR/LE signals

### 9.10.1 Programming example 1: Measuring modulation accuracy

This example demonstrates how to determine modulation characteristics for a Bluetooth signal in a remote environment.

```
//----- Preparing the application -----
// Preset the instrument
*RST
// Start the Bluetooth option
INSTRument:SElect BTO

//-----Configuring the measurement -----
//Select the Bluetooth basic rate standard
CONF:BTO BR
//Select the modulation accuracy measurement
CONF:BTO:MEAS MOD

//-----Performing the Measurement-----
//Select single sweep mode.
INIT:CONT OFF
//Initiate a new measurement and wait until the sweep has finished.
INIT;*WAI

//-----Retrieving Results-----
//Check the result of the limit check
CALC:LIM:FAIL?
```

```
// Store the result summary data to a file.
MMEMory:STORe2:TRAC 1, 'C:\TraceResults'
```

## 9.10.2 Programming example 2: Measuring in-band spurious emissions

This example demonstrates how to determine and check in-band spurious emissions for a Bluetooth signal in a remote environment. It corresponds to the [Chapter 8.2, "Measurement example 2: Analyzing in-band spurious emissions for a basic Bluetooth signal"](#), on page 104 for manual operation.

```
//----- Preparing the application -----
// Preset the instrument
*RST
// Start the Bluetooth option
INSTrument:SElect BTO

//-----Configuring the measurement -----
//Select the Bluetooth basic rate standard
CONF:BTO BR
//Select the in-band spurious emissions measurement
CONF:BTO:MEAS SEM
//Load the predefined settings file
CONF:BTO:LOAD 'C:\R_S\INSTR\USER\predefined\BTOPredefined\
Bluetooth_DH1DH3DH5.xml'
//Select the channel 39 as the transmit channel.
CONF:BTO:CHAN 39

//-----Performing the Measurement-----
//Select single sweep mode.
INIT:CONT OFF
//Initiate a new measurement and wait until the sweep has finished.
INIT;*WAI

//-----Retrieving Results-----
//Check the result of the limit check
CALC:LIM:FAIL?

// Store the result summary data to a file.
MMEMory:STORe2:TRAC 1, 'C:\TraceResults'

//Determine the limit check result for the channel at -3 MHz offset from the
//TX channel = channel 39-3 = 36
TRAC2:DATA? TRACe1
//Result:
//5 general results:
//<TxChannelPower>,<TxChannelFrequency>,<NumberOfExceptions>,
//<AdjacentChannelPowerLower>,<AdjacentChannelPowerUpper>,<
```

```
//35*4 channel results  
//<ChannelNumberChannel136>,<ChannelFrequencyChannel136>,<PowerChannel136>,  
//The 149th result value is the required limit check result:  
//<LimitChannel136>
```

# Annex

## A Predefined standards and settings

You can configure the R&S FSV3 Bluetooth measurement application using predefined standard settings. This allows for quick and easy configuration for commonly performed measurements.

The default storage location for the settings files is:

C:\R\_S\INSTR\USER\predefined\BTOPredefined.

### Predefined settings

The following parameters can be stored in a standard settings file. Any parameters that are not included in the xml file are set to their default values when the standard is loaded.

**Table A-1: List of predefined standards and settings**

File name	Standard	Capt. channels	Capt. time	Sweep count	Trigger source	Trigger level	Trigger drop-out time	Trigger slope	Trigger holdoff	Gated trigger	Gate delay	Gate length
BT_DH1	BR	79	100 ms	10	Free Run	-14 dBm	0	Rising	0	Off	0	0
BT_DH3	BR	79	100 $\mu$ s	10	Free Run	-14 dBm	0	Rising	0	Off	0	0
BT_DH5	BR	79	100 $\mu$ s	10	Free Run	-14 dBm	0	Rising	0	Off	0	0
BT_2-DH1	EDR	79	700 $\mu$ s	10	RF Power	-14 dBm	0	Rising	625 $\mu$ s	On	129.5 $\mu$ s	268 $\mu$ s
BT_2-DH3	EDR	79	2.1 ms	10	RF Power	-14 dBm	0	Rising	625 $\mu$ s	On	129.5 $\mu$ s	1520 $\mu$ s
BT_2-DH5	EDR	79	3.5 ms	10	RF Power	-14 dBm	0	Rising	625 $\mu$ s	On	129.5 $\mu$ s	2772 $\mu$ s
BT_3-DH1	EDR	79	700 $\mu$ s	10	RF Power	-14 dBm	0	Rising	625 $\mu$ s	On	129.5 $\mu$ s	268 $\mu$ s
BT_3-DH3	EDR	79	2.1 ms	10	RF Power	-14 dBm	0	Rising	625 $\mu$ s	On	129.5 $\mu$ s	1520 $\mu$ s
BT_3-DH5	EDR	79	3.5 ms	10	RF Power	-14 dBm	0	Rising	625 $\mu$ s	On	129.5 $\mu$ s	2772 $\mu$ s

## Glossary: Abbreviations

### A

**ACL:** Asynchronous connection-oriented logical transport mode

**AoA:** Angle of arrival  
Direction finding method

**AoD:** Angle of departure  
Direction finding method

### B

**BER:** Bit error rate

**BR:** Basic rate  
Bluetooth operating mode

### C

**CTE:** Constant tone extension

### D

**DEVm:** Differential error vector magnitude

**DPSK:** Differential phase shift keying

**DUT:** Device under test

### E

**EDR:** Enhanced data rate  
Bluetooth operating mode

**eSCO:** Extended synchronous connection-oriented logical transport mode

### F

**f1:** Frequency of the first test signal (00001111)

**f2:** Frequency of the seconds test signal (01010101)

**FHS:** Frequency hop synchronization

### G

**GFSK:** Gaussian frequency shift keying

**I**

**IBSM:** In-band spurious emissions measurement

**ICT:** Initial carrier frequency tolerance

**L**

**LAP:** Lower address part

**LE:** Low energy  
Bluetooth operating mode

**LSB:** Least significant bit first  
Describes the order of bits in symbols

**M**

**MIC:** Message integrity check

**MSB:** Most significant bit first  
Describes the order of bits in symbols

**P**

**p0:** First preamble bit

**PDU:** Protocol data unit

**S**

**SCO:** Synchronous connection-oriented logical transport mode

**U**

**UAP:** Upper address part

## List of commands (Bluetooth)

[SENSe:]ADJust:CONFigure:HYSTeresis:LOWer.....	142
[SENSe:]ADJust:CONFigure:HYSTeresis:UPPer.....	142
[SENSe:]ADJust:CONFigure:LEVel:DURation.....	141
[SENSe:]ADJust:CONFigure:LEVel:DURation:MODE.....	142
[SENSe:]ADJust:LEVel.....	143
[SENSe:]BANDwidth[:RESolution].....	135
[SENSe:]CORRection:EGain:INPut[:MAGNitude].....	147
[SENSe:]DDEMod:SEARch:PULSe:OFFSet.....	200
[SENSe:]DDEMod:SEARch:PULSe:STATe.....	200
[SENSe:]DDEMod:SEARch:SYNC:LAP.....	200
[SENSe:]DDEMod:SEARch:SYNC:LAP:AUTO.....	200
[SENSe:]DDEMod:SEARch:SYNC:OFFSet.....	201
[SENSe:]DDEMod:SEARch:SYNC:STATe.....	201
[SENSe:]DDEMod:SEARch:SYNC:UAP.....	201
[SENSe:]DDEMod:SEARch:SYNC:UAP:AUTO.....	201
[SENSe:]FREQuency:CENTer.....	130
[SENSe:]FREQuency:CENTer.....	169
[SENSe:]FREQuency:CENTer:STEP.....	131
[SENSe:]FREQuency:CENTer:STEP.....	169
[SENSe:]FREQuency:CENTer:STEP:LINK.....	131
[SENSe:]FREQuency:CENTer:STEP:LINK.....	170
[SENSe:]FREQuency:CENTer:STEP:LINK:FACTor.....	132
[SENSe:]FREQuency:OFFSet.....	132
[SENSe:]SWEep:COUNT.....	170
[SENSe:]SWEep:EGATe.....	136
[SENSe:]SWEep:EGATe:AUTO.....	136
[SENSe:]SWEep:EGATe:CONTInuous:PCOunt.....	137
[SENSe:]SWEep:EGATe:CONTInuous:PLENght.....	137
[SENSe:]SWEep:EGATe:CONTInuous[:STATe].....	137
[SENSe:]SWEep:EGATe:HOLDoff.....	138
[SENSe:]SWEep:EGATe:LENGth.....	138
[SENSe:]SWEep:EGATe:LEVel:IFPower.....	139
[SENSe:]SWEep:EGATe:LEVel:RFPower.....	139
[SENSe:]SWEep:EGATe:LEVel[:EXTernal<tp>].....	138
[SENSe:]SWEep:EGATe:POLarity.....	140
[SENSe:]SWEep:EGATe:SKIP.....	140
[SENSe:]SWEep:EGATe:SOURce.....	140
[SENSe:]SWEep:EGATe:TYPE.....	141
[SENSe:]SWEep:TIME.....	171
ABORT.....	148
CALCulate<n>:DELTaMarker<m>:AOFF.....	179
CALCulate<n>:DELTaMarker<m>:LINK.....	179
CALCulate<n>:DELTaMarker<m>:MAXimum:LEFT.....	183
CALCulate<n>:DELTaMarker<m>:MAXimum:NEXT.....	183
CALCulate<n>:DELTaMarker<m>:MAXimum:RIGHT.....	183
CALCulate<n>:DELTaMarker<m>:MAXimum[:PEAK].....	183
CALCulate<n>:DELTaMarker<m>:MINimum:LEFT.....	184



CALCulate<n>:DELtAmarker<m>:MINimum:NEXT.....	184
CALCulate<n>:DELtAmarker<m>:MINimum:RIGHT.....	184
CALCulate<n>:DELtAmarker<m>:MINimum[:PEAK].....	184
CALCulate<n>:DELtAmarker<m>:MREference.....	180
CALCulate<n>:DELtAmarker<m>:TRACe.....	181
CALCulate<n>:DELtAmarker<m>:X.....	180
CALCulate<n>:DELtAmarker<m>:Y?.....	180
CALCulate<n>:DELtAmarker<m>[:STATe].....	181
CALCulate<n>:DELtAmarker<ms>:LINK:TO:MARKer<md>.....	179
CALCulate<n>:LIMit:FAIL?.....	195
CALCulate<n>:LIMit:TRACe<t>:CHECK.....	154
CALCulate<n>:MARKer<m>:AOFF.....	176
CALCulate<n>:MARKer<m>:LINK.....	176
CALCulate<n>:MARKer<m>:MAXimum:LEFT.....	185
CALCulate<n>:MARKer<m>:MAXimum:NEXT.....	185
CALCulate<n>:MARKer<m>:MAXimum:RIGHT.....	185
CALCulate<n>:MARKer<m>:MAXimum[:PEAK].....	185
CALCulate<n>:MARKer<m>:MINimum:LEFT.....	186
CALCulate<n>:MARKer<m>:MINimum:NEXT.....	186
CALCulate<n>:MARKer<m>:MINimum:RIGHT.....	186
CALCulate<n>:MARKer<m>:MINimum[:PEAK].....	186
CALCulate<n>:MARKer<m>:TRACe.....	177
CALCulate<n>:MARKer<m>:X.....	178
CALCulate<n>:MARKer<m>:Y?.....	178
CALCulate<n>:MARKer<m>[:STATe].....	177
CALCulate<n>:MARKer<ms>:LINK:TO:MARKer<md>.....	177
CALCulate<n>:UNIT:POWER.....	125
CONFigure:BT0oth:CFStability:BFRequency:LLIMit.....	164
CONFigure:BT0oth:CFStability:BFRequency:ULIMit.....	164
CONFigure:BT0oth:CFStability:IFRequency:LLIMit.....	165
CONFigure:BT0oth:CFStability:IFRequency:ULIMit.....	165
CONFigure:BT0oth:CFStability:TFRequency:LLIMit.....	165
CONFigure:BT0oth:CFStability:TFRequency:ULIMit.....	166
CONFigure:BT0oth:CHANnel.....	147
CONFigure:BT0oth:CHFormat.....	148
CONFigure:BT0oth:CRC:MOPass.....	153
CONFigure:BT0oth:DH<pt>:FDRift:LLIMit.....	154
CONFigure:BT0oth:DH<pt>:FDRift:ULIMit.....	155
CONFigure:BT0oth:DH<pt>:MDRate:LLIMit.....	155
CONFigure:BT0oth:DH<pt>:MDRate:ULIMit.....	155
CONFigure:BT0oth:FDRift:LLIMit.....	156
CONFigure:BT0oth:FDRift:ULIMit.....	156
CONFigure:BT0oth:FOFFset:LLIMit.....	156
CONFigure:BT0oth:FOFFset:ULIMit.....	157
CONFigure:BT0oth:IBSemissions:FLIMit.....	172
CONFigure:BT0oth:IBSemissions:GEOgraphy.....	171
CONFigure:BT0oth:IBSemissions:L2MHz.....	173
CONFigure:BT0oth:IBSemissions:L4MHz.....	173
CONFigure:BT0oth:IBSemissions:L5MHz.....	173
CONFigure:BT0oth:IBSemissions:NCHannels.....	171

CONFigure:BT00th:IBSemiissions:NFAilures.....	173
CONFigure:BT00th:IBSemiissions:NLIMit.....	174
CONFigure:BT00th:IBSemiissions:RLIMit.....	174
CONFigure:BT00th:ICFTolerance:LLIMit.....	157
CONFigure:BT00th:ICFTolerance:ULIMit.....	157
CONFigure:BT00th:IFDRift:LLIMit.....	158
CONFigure:BT00th:IFDRift:ULIMit.....	158
CONFigure:BT00th:LENergy.....	117
CONFigure:BT00th:LOAD.....	171
CONFigure:BT00th:MDRate:LLIMit.....	158
CONFigure:BT00th:MDRate:ULIMit.....	159
CONFigure:BT00th:MEASurement.....	117
CONFigure:BT00th:MEASurement:BWIDth?.....	143
CONFigure:BT00th:MEASurement:FILTer.....	143
CONFigure:BT00th:MODulation:DQ99:ULIMit.....	166
CONFigure:BT00th:MODulation:F1AVerage:LLIMit.....	159
CONFigure:BT00th:MODulation:F1AVerage:ULIMit.....	159
CONFigure:BT00th:MODulation:F1Max:IRANge.....	160
CONFigure:BT00th:MODulation:F1Max:LLIMit.....	160
CONFigure:BT00th:MODulation:F2Max:IRANge.....	160
CONFigure:BT00th:MODulation:F2Max:LLIMit.....	161
CONFigure:BT00th:MODulation:FDIVision:LLIMit.....	160
CONFigure:BT00th:MODulation:P8PSk:ULIMit.....	166
CONFigure:BT00th:MODulation:PDQPsk:ULIMit.....	167
CONFigure:BT00th:MODulation:PS99:ULIMit.....	167
CONFigure:BT00th:MODulation:R8PSk:ULIMit.....	167
CONFigure:BT00th:MODulation:RDQPsk:ULIMit.....	168
CONFigure:BT00th:PBSCo.....	147
CONFigure:BT00th:POWer:AVERage:LLIMit.....	161
CONFigure:BT00th:POWer:AVERage:START.....	152
CONFigure:BT00th:POWer:AVERage:STOP.....	153
CONFigure:BT00th:POWer:AVERage:ULIMit.....	161
CONFigure:BT00th:POWer:PEAK:RLIMit.....	162
CONFigure:BT00th:POWer:PEAK:ULIMit.....	162
CONFigure:BT00th:PTYPe.....	144
CONFigure:BT00th:RTPower:DAVerage:START.....	163
CONFigure:BT00th:RTPower:DAVerage:STOP.....	163
CONFigure:BT00th:RTPower:GAVerage:START.....	163
CONFigure:BT00th:RTPower:GAVerage:STOP.....	163
CONFigure:BT00th:RTPower:LLIMit.....	168
CONFigure:BT00th:RTPower:ULIMit.....	168
CONFigure:BT00th:SEARch:PULSe:STATe.....	145
CONFigure:BT00th:SEARch:SYNC:LAP.....	145
CONFigure:BT00th:SEARch:SYNC:LAP:AUTO.....	145
CONFigure:BT00th:SEARch:SYNC:STATe.....	146
CONFigure:BT00th:SEARch:SYNC:UAP.....	146
CONFigure:BT00th:SEARch:SYNC:UAP:AUTO.....	146
CONFigure:BT00th:STORe.....	172
CONFigure:BT00th[:STANdard].....	116
DIAGnostic:SERVice:NSORce.....	122

DISPlay:FORMat.....	187
DISPlay[:WINDow<n>]:MINFo[:STATe].....	181
DISPlay[:WINDow<n>]:MTABle.....	182
DISPlay[:WINDow<n>]:SIZE.....	187
DISPlay[:WINDow<n>]:TABLe:ITEM.....	174
DISPlay[:WINDow<n>][:SUBWindow<w>]:TRACe<t>:Y[:SCALe]:RLEVel.....	126
DISPlay[:WINDow<n>][:SUBWindow<w>]:TRACe<t>:Y[:SCALe]:RLEVel:OFFSet.....	126
FORMat:DEXPort:DSEParator.....	195
FORMat:DEXPort:HEADer.....	196
INITiate:SEQuencer:ABORT.....	150
INITiate:SEQuencer:IMMediate.....	150
INITiate:SEQuencer:MODE.....	151
INITiate<n>:CONMeas.....	149
INITiate<n>:CONTinuous.....	149
INITiate<n>[:IMMediate].....	150
INPut:ATTenuation.....	128
INPut:ATTenuation:AUTO.....	129
INPut:ATTenuation:AUTO:MODE.....	127
INPut:ATTenuation:PROTection:RESet.....	118
INPut:CONNector.....	127
INPut:COUPling.....	118
INPut:DPATH.....	119
INPut:EATT.....	129
INPut:EATT:AUTO.....	130
INPut:EATT:STATe.....	130
INPut:EGAIN[:STATe].....	127
INPut:FILE:PATH.....	121
INPut:FILTer:HPASs[:STATe].....	119
INPut:FILTer:YIG[:STATe].....	119
INPut:GAIN:STATe.....	128
INPut:GAIN[:VALue].....	128
INPut:IMPedance.....	120
INPut:IMPedance:PTYPE.....	120
INPut:SElect.....	120
INPut:TYPE.....	120
INSTRument:CREate:DUPLicate.....	113
INSTRument:CREate:REPLace.....	113
INSTRument:CREate[:NEW].....	113
INSTRument:DELeTe.....	114
INSTRument:LIST?.....	114
INSTRument:REName.....	115
INSTRument[:SElect].....	115
LAYout:ADD[:WINDow]?.....	188
LAYout:CATalog[:WINDow]?.....	189
LAYout:IDENtify[:WINDow]?.....	190
LAYout:MOVE[:WINDow].....	190
LAYout:REMove[:WINDow].....	190
LAYout:REPLace[:WINDow].....	191
LAYout:SPLitter.....	191
LAYout:WINDow<n>:ADD?.....	193

LAYout:WINDow<n>:IDENtify?	193
LAYout:WINDow<n>:REMOve	194
LAYout:WINDow<n>:REPLace	194
MMEMory:STORe:BT:MEAS	196
MMEMory:STORe<n>:TRACe	196
OUTPut:IF:SBANd?	122
OUTPut:IF[:SOURce]	123
OUTPut:TRIGger<tp>:DIRectioN	123
OUTPut:TRIGger<tp>:LEVel	123
OUTPut:TRIGger<tp>:OTYPe	124
OUTPut:TRIGger<tp>:PULSe:IMMEDIATE	124
OUTPut:TRIGger<tp>:PULSe:LENGth	125
SYSTem:PRESet:CHANnel[:EXEC]	116
SYSTem:SEQuencer	151
TRACe<n>[:DATA]?	197
TRIGger[:SEQuence]:DTIME	133
TRIGger[:SEQuence]:HOLDoff[:TIME]	133
TRIGger[:SEQuence]:IFPower:HOLDoff	133
TRIGger[:SEQuence]:IFPower:HYSteresis	133
TRIGger[:SEQuence]:LEVel:IFPower	134
TRIGger[:SEQuence]:LEVel[:EXTernal<port>]	134
TRIGger[:SEQuence]:SLOPe	134
TRIGger[:SEQuence]:SOURce	135