

R&S®NRT-Z14/44

Directional Power Sensor

User Manual



1179381502
Version 06

ROHDE & SCHWARZ
Make ideas real



This document describes the following directional power sensor models with firmware version 3.01 and higher:

- R&S®NRT-Z14 (1444.0006K02)
- R&S®NRT-Z44 (1444.0012K02)

This document describes the following accessories:

- R&S®NRT-Z5 (1400.6909K02)
- R&S®NRT-Z2 (1081.2505K10, 1081.2505K30)

© 2024 Rohde & Schwarz

Muehldorfstr. 15, 81671 Muenchen, Germany

Phone: +49 89 41 29 - 0

Email: info@rohde-schwarz.com

Internet: www.rohde-schwarz.com

Subject to change – data without tolerance limits is not binding.

R&S® is a registered trademark of Rohde & Schwarz GmbH & Co. KG.

All other trademarks are the properties of their respective owners.

1179.3815.02 | Version 06 | R&S®NRT-Z14/44

Throughout this document, R&S® is indicated as R&S.

Contents

1	Safety and regulatory information.....	7
1.1	Safety instructions.....	7
1.2	Labels on the product.....	8
1.3	Warning messages in the documentation.....	9
2	Welcome.....	10
2.1	Documentation overview.....	10
2.1.1	Getting started manual.....	10
2.1.2	User manual.....	10
2.1.3	Instrument security procedures.....	10
2.1.4	Printed safety instructions.....	10
2.1.5	Specifications documents and brochures.....	11
2.1.6	Release notes and open source acknowledgment (OSA).....	11
2.2	Key features.....	11
3	Getting started.....	13
3.1	Preparing for use.....	13
3.1.1	Unpacking and checking.....	13
3.1.2	Choosing the operating site.....	13
3.1.3	Considerations for test setup.....	13
3.1.4	Connecting to source and load.....	14
3.1.5	Connecting to a computer or base unit.....	15
3.2	Sensor tour.....	17
3.2.1	RF connectors.....	18
3.2.2	Host interface.....	18
3.2.3	Power handling capacity.....	18
3.2.4	R&S NRT-Z5 USB interface adapter.....	19
4	Operating concepts.....	20
4.1	Base unit.....	20
4.2	R&S Virtual NRT.....	20
4.3	Remote control.....	22
4.3.1	Remote control using R&S Virtual NRT.....	23

4.3.2	Remote control using terminal program.....	23
5	Measurement basics.....	28
6	Firmware update.....	29
6.1	Downloading the firmware update file.....	29
6.2	Updating the firmware.....	29
6.3	R&S NRP-Toolkit.....	30
6.3.1	System requirements.....	31
6.3.2	Installation.....	31
7	Remote control commands.....	32
7.1	Measurement setting commands.....	32
7.1.1	BURS.....	32
7.1.2	CCDF.....	33
7.1.3	DIR.....	33
7.1.4	DISP.....	34
7.1.5	FREQ.....	36
7.1.6	FILT.....	36
7.1.7	FOR.....	40
7.1.8	MOD.....	44
7.1.9	OFFS.....	46
7.1.10	PEP.....	46
7.1.11	PORT.....	47
7.1.12	RESET.....	49
7.1.13	REV.....	49
7.1.14	ZERO.....	50
7.2	Query commands.....	51
7.2.1	FTRG.....	51
7.2.2	QSTN.....	52
7.2.3	RTRG.....	52
7.2.4	SPEC.....	52
7.2.5	STAT.....	56
7.3	General commands.....	59
7.4	Self-test.....	63

8	Remote control basics.....	64
8.1	Device-dependent messages.....	64
8.1.1	Structure and syntax of device-dependent messages.....	64
8.1.2	Setting commands and queries.....	64
8.1.3	Device responses.....	66
8.2	Hardware functions.....	70
8.3	Command processing.....	71
8.3.1	Device hardware and data record.....	72
8.3.2	Output unit.....	72
8.3.3	Cyclic background power and temperature measurements.....	72
8.4	Status reporting system.....	72
8.4.1	Device status.....	73
8.4.2	Error status.....	73
9	Troubleshooting.....	77
9.1	Test setup.....	77
9.2	Power-up self-test.....	77
9.3	Self-test.....	77
9.4	Contacting customer support.....	79
10	Testing the rated specifications.....	80
10.1	Test equipment.....	80
10.2	Test setup.....	81
10.3	Test sequences.....	81
10.3.1	Testing the AVG measurement.....	81
10.3.2	Testing the CCDF threshold.....	82
10.3.3	Testing the PEP measurement.....	83
10.3.4	Testing the directivity.....	84
10.3.5	Testing the matching.....	85
10.4	Performance test report.....	85
11	Transporting.....	88
12	Maintenance, storage and disposal.....	89
12.1	Checking and setting the baud rate.....	89
12.2	Regular checks.....	90

12.3 Cleaning..... 91

12.4 Storage..... 91

12.5 Disposal..... 92

List of commands..... 93

Index..... 95

1 Safety and regulatory information

The product documentation helps you use the product safely and efficiently. Follow the instructions provided here and in the following sections.

Intended use

The R&S NRT-Zxx directional sensor is intended for power and reflection measurements in development and for monitoring and maintenance purposes.

Main applications are continuous monitoring of transmitter systems and power measurements with digital modulation. A profound knowledge of the intended application and test setup is required.

The supported base units are listed in the specifications document. Observe the operating conditions and performance limits stated in the specifications document.

Target audience

The target audience is developers and technicians. The required skills and experience in power measurements depend on the used operating concept.

Where do I find safety information?

Safety information is part of the product documentation. It warns you of potential dangers and gives instructions on how to prevent personal injury or damage caused by dangerous situations. Safety information is provided as follows:

- In [Chapter 1.1, "Safety instructions"](#), on page 7. The same information is provided in many languages in printed format. The printed "Safety Instructions" for "Power Sensors" (document number 1171.1865.99) are delivered with the product.
- Throughout the documentation, safety instructions are provided when you need to take care during setup or operation.

1.1 Safety instructions

Products from the Rohde & Schwarz group of companies are manufactured according to the highest technical standards. To use the products safely, follow the instructions provided here and in the product documentation. Keep the product documentation nearby and offer it to other users.

Use the product only for its intended use and within its performance limits. Intended use and limits are described in the product documentation such as the specifications document, manuals and the printed "Safety Instructions" document. If you are unsure about the appropriate use, contact Rohde & Schwarz customer support.

Using the product requires specialists or specially trained personnel. These users also need sound knowledge of at least one of the languages in which the user interfaces and the product documentation are available.

Reconfigure or adjust the product only as described in the product documentation or the specifications document. Any other modifications can affect safety and are not permitted.

Never open the casing of the product. Only service personnel authorized by Rohde & Schwarz are allowed to repair the product. If any part of the product is damaged or broken, stop using the product. Contact Rohde & Schwarz customer support at <https://www.rohde-schwarz.com/support>.

Operating the product

Only use the product indoors. The product casing is not waterproof.

Observe the ambient conditions such as altitude, operating temperature and climatic loads; see the specifications document.



Connecting directional power sensors

During the measurement, the RF power flow can be high. Connect both RF connectors tightly to avoid power leakage. Contact with leaking RF power can cause electric shock and severe skin burns. Take the following measures for your safety:

- Before switching on the RF power of your test setup, make sure that both RF ports of the power sensor are connected securely as described in the product documentation.
- Do not touch the RF ports when the RF power is switched on.
- Never exceed the permissible continuous power that is shown in the diagram on the back of the power sensor.
- Before disconnecting one or both RF ports of the power sensor, switch off the RF power.

Meaning of safety labels

Safety labels on the product warn against potential hazards.

	<p>Potential hazard Read the product documentation to avoid personal injury or product damage.</p>
	<p>Hot surface Do not touch. Risk of skin burns. Risk of fire.</p>

1.2 Labels on the product

Labels on the product inform about:

- Personal safety
See "[Meaning of safety labels](#)" on page 8.
- Environment safety

See [Table 1-1](#).

- Identification of the product
A label on the sensor shows the serial number that uniquely identifies the sensor.
- Power handling capacity
See "[Signal input and output levels](#)" on page 14.

Table 1-1: Labels regarding environment safety

	<p>Labeling in line with EN 50419 for disposal of electrical and electronic equipment after the product has come to the end of its life.</p> <p>For more information, see "Disposing of electrical and electronic equipment" on page 92.</p>
-----------------------------------------------------------------------------------	--------------------------------------------------------------------------------------------------------------------------------------------------------------------------------------------------------------------------------------------------------------

1.3 Warning messages in the documentation

A warning message points out a risk or danger that you need to be aware of. The signal word indicates the severity of the safety hazard and how likely it will occur if you do not follow the safety precautions.

CAUTION

Potentially hazardous situation. Could result in minor or moderate injury if not avoided.

NOTICE

Potential risks of damage. Could result in damage to the supported product or to other property.

2 Welcome

This section provides an overview of the user documentation and an introduction to the R&S NRT-Zxx.

2.1 Documentation overview

This section provides an overview of the R&S NRT-Zxx user documentation. Unless specified otherwise, you find the documents at:

www.rohde-schwarz.com/manual/NRT2

Further documents are available at:

www.rohde-schwarz.com/product/NRT2

2.1.1 Getting started manual

Introduces the R&S NRT-Zxx and describes how to set up and start working with the product. Includes basic operations and general information, e.g. safety instructions, etc. A printed version is delivered with the product.

2.1.2 User manual

Contains the description of all R&S NRT-Zxx functions. It also provides an introduction to remote control, a complete description of the remote control commands with programming examples, and information on maintenance and interfaces. Includes the contents of the getting started manual.

2.1.3 Instrument security procedures

Deals with security issues when working with the R&S NRT-Zxx in secure areas. It is available for download on the internet.

2.1.4 Printed safety instructions

Provides safety information in many languages. The printed document is delivered with the product.

2.1.5 Specifications documents and brochures

The specifications document, also known as the data sheet, contains the technical specifications of the R&S NRT-Zxx. It also lists the firmware applications and their order numbers, and optional accessories.

The brochure provides an overview of the instrument and deals with the specific characteristics.

www.rohde-schwarz.com/brochure-datasheet/NRT2

2.1.6 Release notes and open source acknowledgment (OSA)

The release notes list new features, improvements and known issues of the current firmware version, and describe the firmware installation.

The open source acknowledgment contains verbatim license texts of the used open source software.

www.rohde-schwarz.com/firmware/NRT2

2.2 Key features

The R&S NRT-Zxx support the following measurements:

Average power (RMS value)

Returns the average value of the power for any type of measurement signal — modulated, unmodulated or several carriers.

Peak envelope power (PEP) and crest factor

Both parameters provide information on the peak power of a modulated envelope and describe the overdrive characteristics of transmitter output stages. The sensor outputs the result of the crest factor measurement as the ratio of peak envelope power (PEP) to average power. In the graphical user interface of the base unit or the R&S Virtual NRT, the crest factor is displayed as a logarithmic ratio in dB. Measurements are performed using a video bandwidth that is adjustable in several steps, so that even short-time and high-power peaks can be determined.

Average burst power

Used to measure modulated and unmodulated bursts based on the average power and the duty cycle. The duty cycle can be defined or determined automatically by the sensor.

Complementary cumulative distribution function (CCDF)

Measures the probability of the peak envelope power exceeding a preset threshold so that the amplitude distribution of signals with an unknown envelope can be determined.

Voltage standing wave ratio (VSWR), reflection coefficient, return loss

These parameters provide information on the matching of the load. The sensor derives these parameters from the average power measurement in forward and reverse direction.

3 Getting started

3.1 Preparing for use

Here, you can find basic information about setting up the product for the first time.

3.1.1 Unpacking and checking

1. Unpack the product carefully.
2. Retain the original packing material. Use it when transporting or shipping the product later.
3. Using the delivery notes, check the equipment for completeness.
4. Check the equipment for damage.

If the delivery is incomplete or equipment is damaged, contact Rohde & Schwarz.

3.1.2 Choosing the operating site

Specific operating conditions ensure proper operation and avoid damage to the product and connected devices. For information on environmental conditions such as ambient temperature and humidity, see the specifications document.

Electromagnetic compatibility classes

The electromagnetic compatibility (EMC) class indicates where you can operate the product. The EMC class of the product is given in the specifications document.

- Class B equipment is suitable for use in:
 - Residential environments
 - Environments that are directly connected to a low-voltage supply network that supplies residential buildings
- Class A equipment is intended for use in industrial environments. It can cause radio disturbances in residential environments due to possible conducted and radiated disturbances. It is therefore not suitable for class B environments. If class A equipment causes radio disturbances, take appropriate measures to eliminate them.

3.1.3 Considerations for test setup

Electromagnetic interference (EMI) can affect the measurement results.

To suppress electromagnetic radiation during operation:

- Use high-quality shielded cables, for example, double-shielded RF and interface cables.
- Always terminate open cable ends.
- Ensure that connected external devices comply with EMC regulations.

Signal input and output levels

Information on signal levels is provided in the specifications document. Keep the signal levels within the specified ranges to avoid damage to the product and connected devices.

Information on power handling capacity is given also on the back of the sensor. A derating diagram shows the power handling capacity of the sensor maximum forward power versus frequency, under different conditions such as temperature and VSWR of the load.

3.1.4 Connecting to source and load

The arrow on the sensor front side shows the forward power flow.

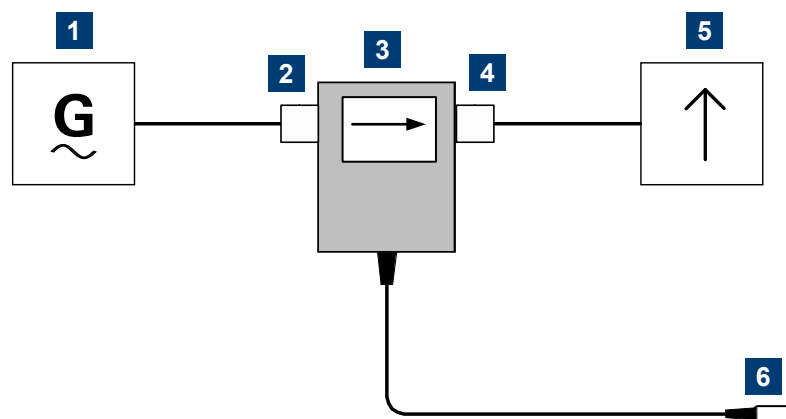

Figure 3-1: Connecting to source and load

- 1 = Source
- 2 = Port 1 (RF connector)
- 3 = R&S NRT-Zxx sensor
- 4 = Port 2 (RF connector)
- 5 = Load
- 6 = Host interface connector

Connect the R&S NRT-Zxx sensor as shown in [Figure 3-1](#) and described in the following step-by-step instructions to avoid damage to the sensor and to use all measurements.



If the following applies, you can connect the R&S NRT-Zxx sensor the other way around:

- You want to measure an average of forward power below 30 W with high accuracy.
- Matching measurements are of secondary importance.

To connect to the DUT

1. Connect RF connector (2, port 1) to the source.
 - a) Insert RF connector (2) straight into the RF connector of the source. Take care not to tilt the R&S NRT-Zxx sensor.
 - b) Tighten the RF connector securely by hand.
2. Connect RF connector (4, port 2) to the load.
 - a) Insert RF connector (4) straight into the RF connector of the load. Take care not to tilt the R&S NRT-Zxx sensor.
 - b) Tighten the RF connector tightly by hand.
See "[Connecting directional power sensors](#)" on page 8.

To disconnect from the DUT

1. **CAUTION!** Risk of electric shock and severe skin burns. See "[Connecting directional power sensors](#)" on page 8.
Switch off the RF power before touching the RF connectors.
2. Unscrew the RF connectors by hand.

3.1.5 Connecting to a computer or base unit

For connecting the sensor to a computer or base unit, use the host interface. See [Chapter 3.2.2, "Host interface"](#), on page 18.

For operating the sensor, you can choose from various possibilities. For details, see [Chapter 4, "Operating concepts"](#), on page 20.

3.1.5.1 Computer

As a controller, you can use a computer with a Microsoft Windows operating system, equipped with R&S Virtual NRT or remote control software.

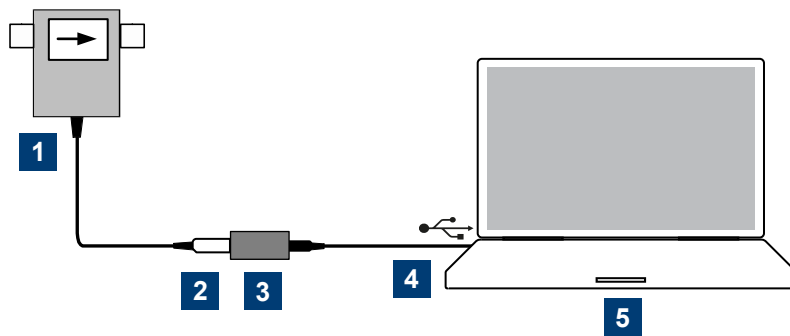

Figure 3-2: Connecting to computer

- 1 = R&S NRT-Zxx directional sensor
- 2 = host interface connector → sensor interface
- 3 = R&S NRT-Z5 USB interface adapter
- 4 = USB connector → USB port
- 5 = computer

To connect to a computer

1. Meet the prerequisites of the R&S NRT-Z5 USB interface adapter described in [Chapter 3.2.4, "R&S NRT-Z5 USB interface adapter"](#), on page 19.
2. Connect the host interface connector of the R&S NRT-Zxx, (2) in [Figure 3-2](#), to the sensor interface of the R&S NRT-Z5.
3. Connect the USB connector of the R&S NRT-Z5 to a USB port of the computer.

Further information:

- [Chapter 4.2, "R&S Virtual NRT"](#), on page 20
- [Chapter 4.3, "Remote control"](#), on page 22

3.1.5.2 Base unit

You can operate the R&S NRT-Zxx on an R&S NRT2 or R&S NRX base unit. The R&S NRX base unit must be equipped with the R&S NRX-B9 sensor interface for R&S NRT.

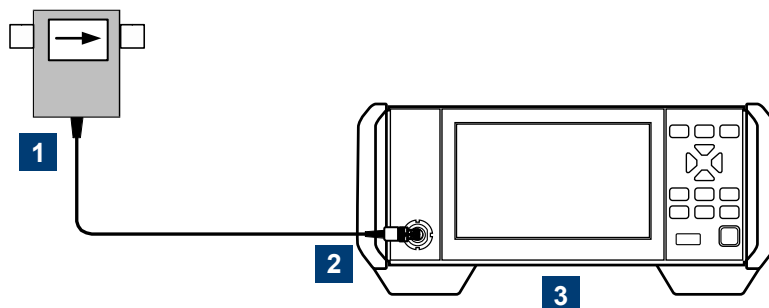

Figure 3-3: Connecting to base unit

- 1 = R&S NRT-Zxx directional sensor
- 2 = host interface connector → sensor interface
- 3 = base unit

To connect to a base unit

- ▶ Connect the host interface connector of the R&S NRT-Zxx, (2) in [Figure 3-3](#), to the sensor interface of the base unit.

The base unit recognizes the sensor a few seconds after the connection is made or after power-up and immediately starts to measure.

If the base unit does not recognize the sensor, check the baud rate setting.

See [Chapter 12.1, "Checking and setting the baud rate"](#), on page 89.

Further information:

- [Chapter 4.1, "Base unit"](#), on page 20
- User manual of the base unit

3.1.5.3 Legacy setups

To support legacy setups, you can also connect the sensor to the following legacy adapters and instruments:

- R&S NRT-Z3 interface adapter
To connect to a computer with standard RS-232 interface.
- R&S NRT-Z4 interface adapter
To connect to a computer with a PCMCIA type II slot.
- R&S NRT
Legacy base unit

3.2 Sensor tour

This section provides an overview of the available connectors of the sensor.

The meanings of the labels on the product are described here and in [Chapter 1.2, "Labels on the product"](#), on page 8.

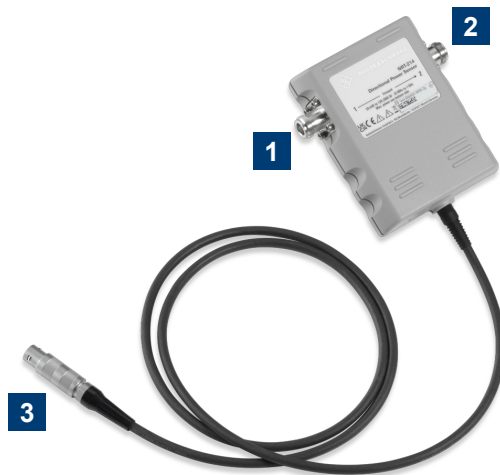

Figure 3-4: R&S NRT-Zxx directional sensor, front side

- 1 = port 1 (RF connector) → connect to source
- 2 = port 2 (RF connector) → connect to load
- 3 = host interface

3.2.1 RF connectors

Always switch off the RF power before touching the RF connectors. See "[Connecting directional power sensors](#)" on page 8.

The RF connectors are used for connecting the sensor between source and load. To help connecting the sensor correctly, the RF connectors are assigned a number, indicated on the front label, see [Figure 3-4](#).

See [Chapter 3.1.4, "Connecting to source and load"](#), on page 14.

3.2.2 Host interface

Used for establishing a connection between the sensor and a computer or base unit. The connection is used for:

- Remote control of the sensor via the serial interface (RS-422).
- Supplying the sensor with DC power.

See [Chapter 3.1.5, "Connecting to a computer or base unit"](#), on page 15.

3.2.3 Power handling capacity

Located on the back of the sensor, there is a derating diagram that shows the power handling capacity of the sensor, forward power in W versus frequency. It is also dependent on ambient temperature and the VSWR of the load. Further information on signal levels is provided in the specifications document. See also "[Signal input and output levels](#)" on page 14.

3.2.4 R&S NRT-Z5 USB interface adapter

This adapter connects the host interface of the R&S NRT-Z5 to the USB port of a computer.

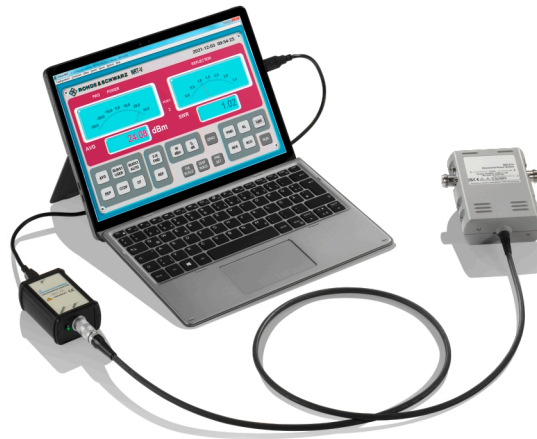

Prerequisites

- The USB port of the computer must be capable to supply at least 500 mA. If necessary, use a self-powered USB hub.
- The drivers for the R&S NRT-Z5 USB interface adapter are installed on the computer.

To install the drivers for the R&S NRT-Z5 USB interface adapter

- ▶ Proceed as described in the technical information delivered with the R&S NRT-Z5 USB interface adapter.

For a detailed setup, see [Chapter 3.1.5.1, "Computer"](#), on page 15.

4 Operating concepts

- [Base unit](#).....20
- [R&S Virtual NRT](#).....20
- [Remote control](#).....22

4.1 Base unit

See also [Chapter 3.1.5.2, "Base unit"](#), on page 16.

Setup

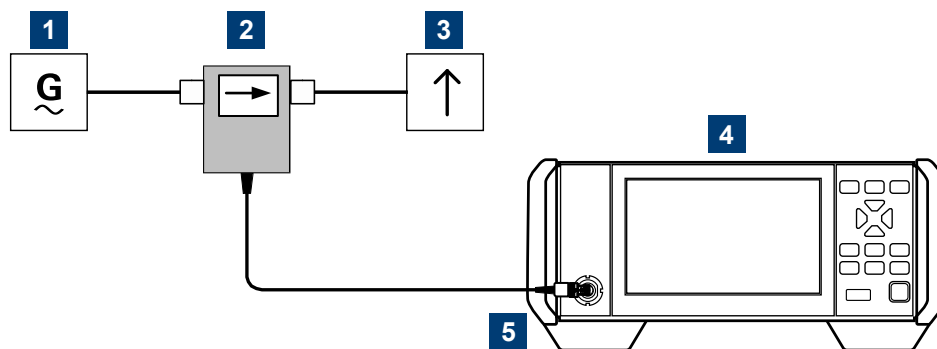

Figure 4-1: Setup for base unit

- 1 = signal source
- 2 = R&S NRT-Zxx directional sensor
- 3 = load
- 4 = base unit
- 5 = host interface connector → sensor interface

Communication between the R&S NRT-Zxx sensor and a base unit is only possible with a baud rate setting of 38400 Bd. This setting is the factory default that needs to be restored if the setting was changed. If the R&S NRT-Zxx sensor is not recognized by the base unit, check that the baud rate setting of the R&S NRT-Zxx sensor is 38400 Bd.

See [Chapter 12.1, "Checking and setting the baud rate"](#), on page 89.

4.2 R&S Virtual NRT

R&S Virtual NRT is a Windows application provided by Rohde & Schwarz for controlling the R&S NRT-Zxx. R&S Virtual NRT provides a graphical user interface supporting:

- Manual operation of the main measurements. For information on the graphical user interface, see the R&S Virtual NRT help.

- Remote control, see [Chapter 4.3.1, "Remote control using R&S Virtual NRT"](#), on page 23.

Installing the program

R&S Virtual NRT is provided on the Rohde & Schwarz website as a separate stand-alone installation package,

https://www.rohde-schwarz.com/software/nrt-z_nap-z/.

- ▶ Save the EXE file on your computer.

Required equipment

- R&S NRT-Zxx
- R&S NRT-Z5 USB interface adapter to connect the R&S NRT-Zxx to the computer; alternatively, you can use a legacy adapter, see [Chapter 3.1.5.3, "Legacy setups"](#), on page 17.
- Computer with Microsoft Windows operating system and the drivers for the R&S NRT-Z5 installed, see ["To install the drivers for the R&S NRT-Z5 USB interface adapter"](#) on page 19.

Setup

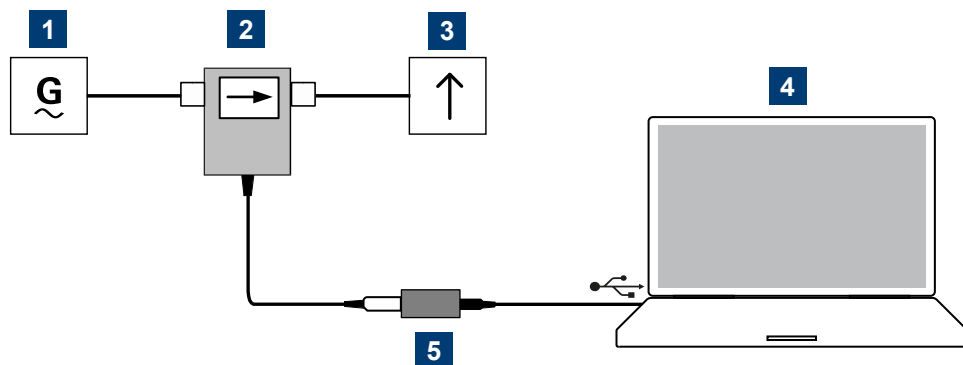

Figure 4-2: Setup for R&S Virtual NRT

- 1 = signal source
- 2 = R&S NRT-Zxx directional sensor
- 3 = load
- 4 = computer with installed R&S Virtual NRT
- 5 = R&S NRT-Z5 USB interface adapter

To start a measurement

1. Connect the R&S NRT-Zxx to the computer as shown in ["Setup"](#) on page 21. For detailed descriptions, refer to:
 - [Chapter 3.1.4, "Connecting to source and load"](#), on page 14
 - [Chapter 3.1.5.1, "Computer"](#), on page 15
2. Switch on the test signal of the signal source.

3. Start R&S Virtual NRT.

A few seconds after the user interface is displayed, when the pointers of the analog indication start wriggling, the R&S NRT-Zxx is ready for operation. For further instructions, see the R&S Virtual NRT help.

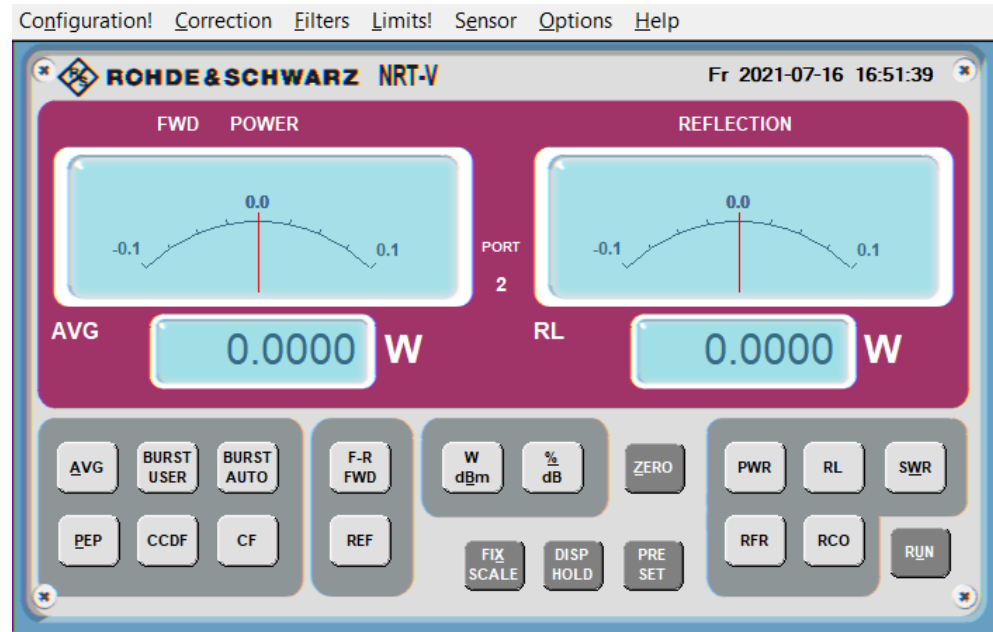

If communication with the R&S NRT-Zxx could not be established, the display is dimmed and the automatic configuration of the interface failed. Proceed with ["To establish the communication"](#) on page 22.

To establish the communication

1. In the "Options" menu, select "RS-232".
Click "Auto Config" to start the automatic configuration again.
2. If automatic configuration does not work, configure the interface settings manually:
 - a) Set baud rate to 38400.
This value is the factory-set value of the R&S NRT-Zxx.
If you want to check the baud rate, proceed as described in [Chapter 12.1, "Checking and setting the baud rate"](#), on page 89.
 - b) Under "COM port", select the virtual COM port that is assigned to the R&S NRT-Z5 USB interface adapter.
 - c) Click "OK".
 - d) Click "RUN".

4.3 Remote control

Using remote control, you can integrate the R&S NRT-Zxx directional sensors into a remote-controlled measurement system or use functions that are not available in man-

ual operation. You can monitor the sensor and support the development of your own test program.

Further information:

- [Chapter 7, "Remote control commands"](#), on page 32
- [Chapter 3.1.5.1, "Computer"](#), on page 15

4.3.1 Remote control using R&S Virtual NRT

In R&S Virtual NRT, remote control is called *direct communication*. R&S Virtual NRT works like a terminal program, but also manages the configuration of the host (computer) and the initialization of the sensor. For general information on R&S Virtual NRT, see [Chapter 4.2, "R&S Virtual NRT"](#), on page 20.

To communicate directly

1. Start as described in ["To start a measurement"](#) on page 21.
2. Wait until you can see the measurement results.
3. In the "Options" menu, select "Direct Communication".
The "Direct Communication" dialog is displayed. Any running measurements are interrupted.
4. In the "Input" field, enter a command, for example ID.
5. Click "SEND".
In the "Output" field, the response of the sensor is displayed.
6. Click "STOP REC" to terminate the ready-to-receive state of R&S Virtual NRT before sending a new command.
7. For each command you want to send, repeat [step 4](#) to [step 6](#).
8. If you want to clear the receiver protocol displayed in the "Output" field, click "CLEAR".
9. Click "CLOSE" to return to manual operation.

4.3.2 Remote control using terminal program

You can use a terminal program of your choice.

4.3.2.1 Interface settings

To set up the connection successfully, the interface settings of the sensor and computer must match.

Sensor interface settings

- Parity: None
- Data bits: 8
- Stop bits: 1
- Start bits: 1
- Protocol: XON / XOFF

You can change the baud rate, see [Chapter 12.1, "Checking and setting the baud rate"](#), on page 89.

Computer interface configuration

- Port connected to the sensor
- Interface parameters same as for sensor, see "[Sensor interface settings](#)" on page 24.
- ASCII configuration: end of transmitted lines with LF

Example: Using the PuTTY terminal program

This example shows the configuration of the PuTTY terminal program (<https://www.putty.org/>).

1. Under "Session", configure as follows:
 - a) "Serial line": Must match the COM port that is assigned to the serial adapter, usually R&S NRT-Z5 USB interface adapter. You can look up this information in the device manager of the operating system.
 - b) Speed: Must match the baud rate setting of the sensor.
See also [Chapter 12.1, "Checking and setting the baud rate"](#), on page 89.
 - c) Connection type: "Serial"
2. If you want to reuse the session settings, you can save them:
 - a) Under "Saved Sessions", enter the name.
 - b) Click "Save".
 - c) To load a session, double-click the list entry.

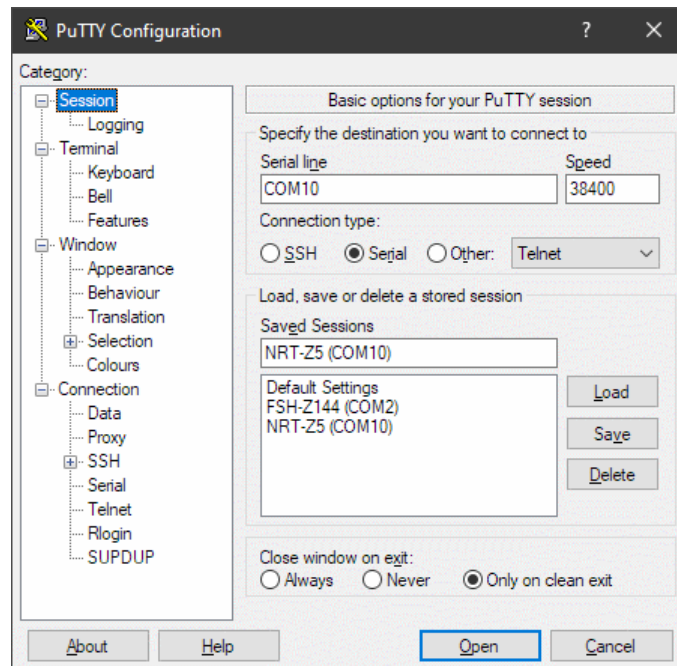

- Recommendation for "Terminal" settings: Set both "Local echo" and "Local line editing" to "Force on". This way, you can see your input and edit the input line.

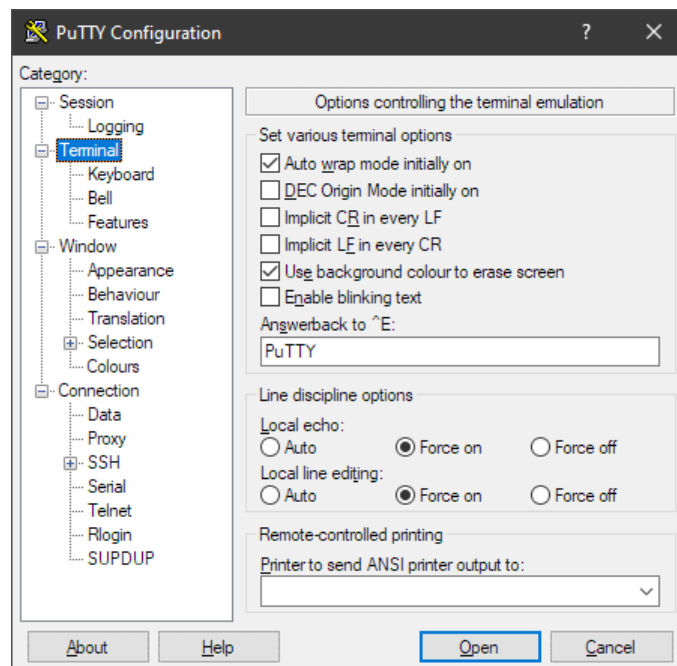

- Under "Connection" > "Serial", configure the parameters of the serial interface.

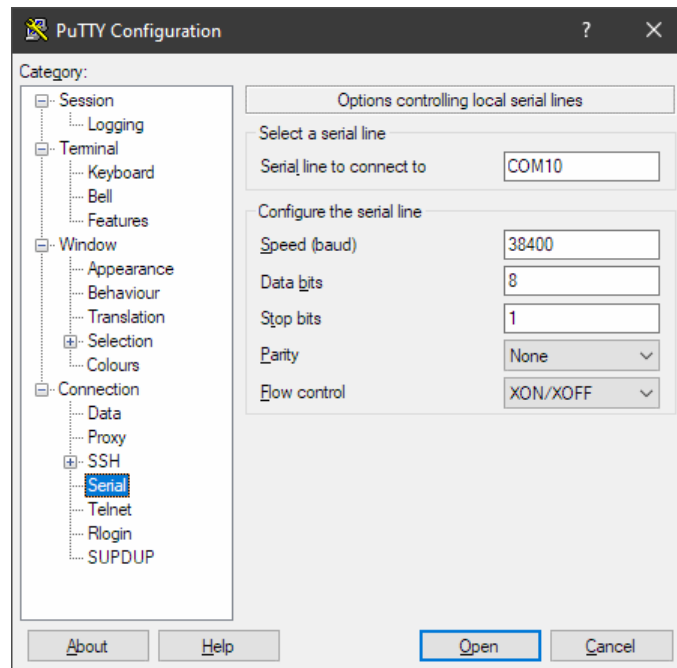

4.3.2.2 Testing the connection

On power-up, the R&S NRT-Zxx responds to commands with one or several lines, if the connection is working.

To ready the sensor for measuring

1. Open the terminal program.
2. Send `appl`.
3. Wait for a response; see [Chapter 4.3.2.3, "Behavior during booting"](#), on page 27.
4. Repeat [step 2](#) and [step 3](#) until the sensor responds with:

```
@8E oper _____
```

After receiving the response, you can make settings and query results.

To test the connection

1. Open the terminal program.
2. Enter the string `test`.
3. Confirm with the return key.

The sensor responds:

```
@17 0 - This is a test string _____
@18 1 - This is a test string _____
@19 2 - This is a test string _____
...
@37 97 - This is a test string _____
```

```
@38 98 - This is a test string_____
@39 99 - This is a test string_____
```

See also [Chapter 4.3.2.3, "Behavior during booting"](#), on page 27.

To query the identification

- ▶ Send the `id` command.

The sensor responds with its identification string.

```
Example: @6E Rohde&Schwarz NRT-Z14 V3.00 2021-12-01_____
```

To query the last result

- ▶ Send `rtrg`.

The sensor responds with:

```
@11 +2.1234E+01 +2.1530E+01 __avr115500 _____
```

Interpreting the response:

- `+2.1234E+01`
Result for measurement direction 1>2; in this example 21.234 W average power
- `+2.1530E+01`
Result for measurement direction 2>1; in this example 21.53 dB return loss.
- `__avr115500`
Sensor status in coded form.
Sensor status in coded form. See also [Chapter 7.2.5, "STAT"](#), on page 56.

See also [Chapter 7.2.1, "FTRG"](#), on page 51.

4.3.2.3 Behavior during booting

On power-up, the sensor is booting. During booting, you can load new firmware.

After booting is completed, a power-up test is performed for approx. 3 s.

Do not interrupt the power-up test. If you send the `appl` command during a power-up test, the sensor responds with:

```
@9B busy_____
```

After the power-up test is completed, send the `appl` command again to ready the sensor for measuring. The sensor responds with:

```
@8C boot_____
```

Now the sensor is ready for operation. If you send the `appl` command again, the sensor responds with:

```
@8E oper_____
```

5 Measurement basics

The R&S NRT-Zxx directional sensor measures the forward and reverse power. The forward power is the power flux from the source to the load.

The ratio of forward and reverse power is a measure of the matching of the load which can be measured as standing wave ratio (SWR), return loss or reflection coefficient.

To observe during the power reflection measurement

- ▶ **CAUTION!** Risk of electric shock and severe skin burns. During the measurement, the RF power flow can be high.



After switching on the RF power, do not touch the RF ports.

Never exceed the permissible continuous power that is shown in the diagram on the back of the sensor.

Further information:

- Setup see [Chapter 3.1.4, "Connecting to source and load"](#), on page 14.

6 Firmware update

- [Downloading the firmware update file](#).....29
- [Updating the firmware](#).....29
- [R&S NRP-Toolkit](#).....30

6.1 Downloading the firmware update file

Firmware update files of R&S sensors generally have an RSU extension, RSU meaning Rohde & Schwarz update.

To download the RSU file

1. Download the most recent firmware version from the Rohde & Schwarz homepage on the internet. The latest firmware update files are available at:
www.rohde-schwarz.com/firmware/NRT2
2. Save the RSU file on the computer.
3. If the RSU file is packed in a *.zip archive, extract it.

6.2 Updating the firmware

Do not interrupt the firmware update because an interruption can lead to missing or faulty firmware. Take special care not to disconnect the power supply while the update is in progress.

To update the firmware

A firmware update can take up to 5 minutes. Ensure that the update is not interrupted.

1. Connect the sensor to the computer as described in [Chapter 3.1.5.1, "Computer"](#), on page 15.
2. Start the Firmware Update program:
"Start" menu > "NRP-Toolkit" > "Firmware Update".
Note: The Firmware Update program is part of the R&S NRP-Toolkit. See also [Chapter 6.3, "R&S NRP-Toolkit"](#), on page 30.
3. Under "Hostname, IP Address or Serial", enter the COM port to which the R&S NRT-Z5 USB interface adapter is connected, for example "COM7". You can look up this information in the device manager of the operating system.

The program automatically starts scanning this COM port for sensors. When the scan is successful, the COM port is listed under "Device".

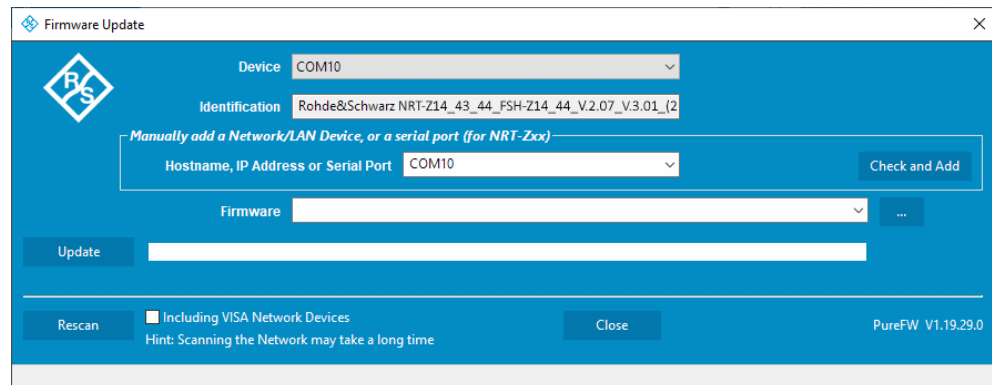

4. Under "Firmware", enter the full path and filename of the update file or press the browse button next to the field. New firmware for the R&S NRT-Zxx has an *.rsu extension.
5. Click "Update".
During the update process, a progress bar is displayed. The update sequence can take a couple of minutes.
6. Check if the update was successful. The firmware version in the "Identification" field must match the version you selected in the "Firmware" field.

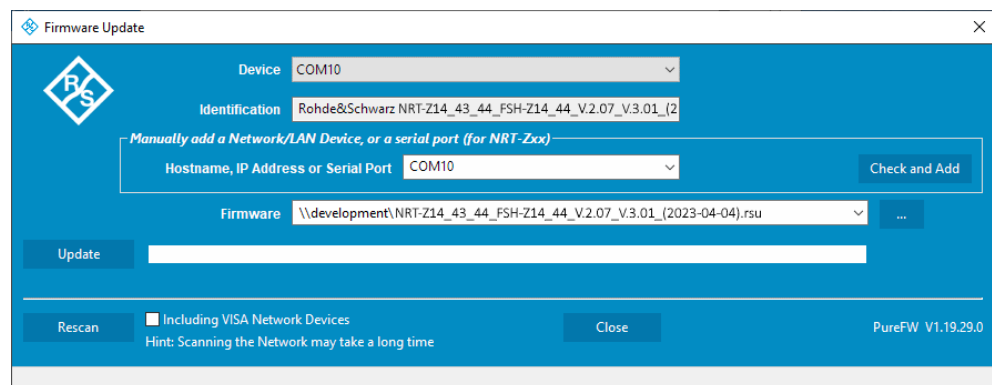

Problems during a firmware update

If, for example, a power cut happened during the firmware update, problems can occur.

1. Perform the firmware update again. Sometimes, a further update fixes the problems.
2. If the sensor is not accessible anymore, contact the service.

6.3 R&S NRP-Toolkit

The Firmware Update program is part of the R&S NRP-Toolkit.

6.3.1 System requirements

Hardware requirements:

- Desktop computer or laptop

For supported Microsoft Windows versions, see the release notes.

6.3.2 Installation

1. Start the R&S NRP-Toolkit installer on the Windows-based computer.
In the "NRP-Toolkit Setup" dialog, the correct R&S NRP-Toolkit version for your operating system, 32-bit or 64-bit, is already selected.
2. Accept the license terms to continue with the installation.
3. Click "Next" and complete the installation process.

7 Remote control commands

Describes all commands useful for measurement tasks. An alphabetic list of all commands is provided at the end of the user manual.

7.1 Measurement setting commands

Enter physical quantities in their basic unit — W, s, Hz. Enter the value without the unit. Values with unit are not recognized.

• BURS.....	32
• CCDF.....	33
• DIR.....	33
• DISP.....	34
• FREQ.....	36
• FILT.....	36
• FOR.....	40
• MOD.....	44
• OFFS.....	46
• PEP.....	46
• PORT.....	47
• RESET.....	49
• REV.....	49
• ZERO.....	50

7.1.1 BURS

This command group sets the burst period and the burst width for the forward calculated burst average measurement, [CBAV](#).

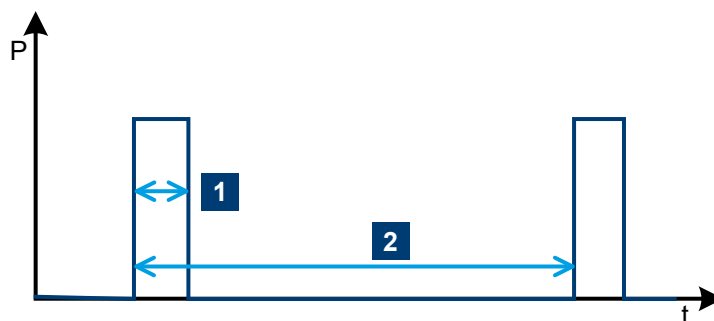

Figure 7-1: Envelope power characteristic of a burst signal

1 = burst width, see [BURS:WIDT](#) on page 33.

2 = burst period, see [BURS:PER](#) on page 33.

Remote commands

BURS:PER	33
BURS:WIDT	33

BURS:PER <num>

Sets the burst period for the forward calculated burst average measurement, [CBAV](#).

Parameters:

<num> Burst period, see [Figure 7-1](#).
 Range: <burst width> to 1.0
 RESET: 1E-2
 Unit: s

Example:

```
BURS:PER 40e-3
@5D old: 1.000000E-02 new: 4.000000E-02_____
```

BURS:WIDT <parameter>

Sets the burst width for the forward calculated burst average measurement, [CBAV](#).

Parameters:

<parameter> Burst width, see [Figure 7-1](#).
 Range: 1E-9 to <burst period>
 RESET: 1E-3
 Unit: s

Example:

```
BURS:WIDT 6.667e-3
@74 old: 1.000000E-03 new: 6.667000E-03_____
```

7.1.2 CCDF**CCDF <num>**

Sets the threshold for the complementary cumulative distribution function measurement, [CCDF](#).

Applies to the measurement position defined by [PORT](#) and [OFFS](#).

Parameters:

<num> Range: 1 to 300
 RESET: 1
 Unit: W

7.1.3 DIR**DIR <parameter>**

Sets the direction of the forward power relative to the sensor ports 1 and 2.

See also [Chapter 3.1.4, "Connecting to source and load"](#), on page 14.

Parameters:

<parameter>

AUTO

The sensor automatically assigns the direction. The greater of the two measured powers are interpreted as forward power. This setting is not advisable if the forward and the reverse powers are approximately equal (total reflection). Then the automatic assignment can be wrong because, due to a measurement error, a higher value is determined for the reverse than for the forward power.

1>2

The forward power direction is fixed from port 1 to port 2.

2>1

The forward power direction is fixed from port 2 to port 1.

RESET: AUTO

7.1.4 DISP

This command group configures the responses for [FTRG](#) and [RTRG](#).

Remote commands

DISP:FORW	34
DISP:REFL	35
DISP:STAT	35

DISP:FORW <parameter>

If enabled, the result for the forward measurement is included in the response.

Parameters:

<parameter>

ON | OFF

RESET: ON

Example:

```

RESET
# Activates default settings.
@30 OK_____

DMA OFF
# Disables filling-up to 50 characters.
@39 old: ON new: OFF_____

RTRG
# Requests result.
@F9 +2.1234E+01 +2.1530E+01 __avr115500

DISP:FORW OFF
# Disables the forward power display.
@D5 old: ON new: OFF

RTRG
# Requests result.
@B3 +2.1530E+01 __avr115500

DISP:FORW ON;DISP:STAT OFF
# Enables the forward power display and
# disables the status display.
@D5 old: OFF new: ON
# For several commands separated by semicolons,
# the responses are output in consecutive order.

RTRG
# Requests result.
@6B +2.1234E+01 +2.1530E+01

```

DISP:REFL <parameter>

If enabled, the result for the reverse measurement is included in the response.

Parameters:

<parameter> ON | OFF
 RESET: ON

DISP:STAT <parameter>

If enabled, the result for the status field is included in the response.

Parameters:

<parameter> ON | OFF
 RESET: ON

7.1.5 FREQ

FREQ <num>

Sets the carrier frequency of the test signal.

With this information, the characteristic frequency response of the sensor can be considered and the results corrected accordingly. Correction is made for the forward and the reverse channel. The values between the stored correction factors are obtained by way of linear interpolation. To achieve the measurement accuracy specified in the specifications document, enter the frequency with an accuracy of about 5 %.

Parameters:

<num>	Range:
	R&S NRT-Z14: 2E6 to 1E9
	R&S NRT-Z44: 2E8 to 4E9
	RESET:
	R&S NRT-Z14: 2E8
	R&S NRT-Z44: 1E9
	Unit: Hz

7.1.6 FILT

This command group sets the averaging filters of the individual measurement paths, the integration time of the A/D converters and the video filters.

Averaging

Averaging of measured values compensates for variations that occur due to unstable test signals or low powers. In the free run mode (trigger setting `FTRG`), a "running average" is formed. That means a fixed number of measured values is averaged continuously, yielding a new output value with every new measured value. The oldest measured value is removed from the filtering process, see [Figure 7-2](#).

The number of measured values that is averaged is called average count and is set using `FILT: AVER: COUN`. The higher the count, the lower the noise, and the longer it takes to obtain a measured value.

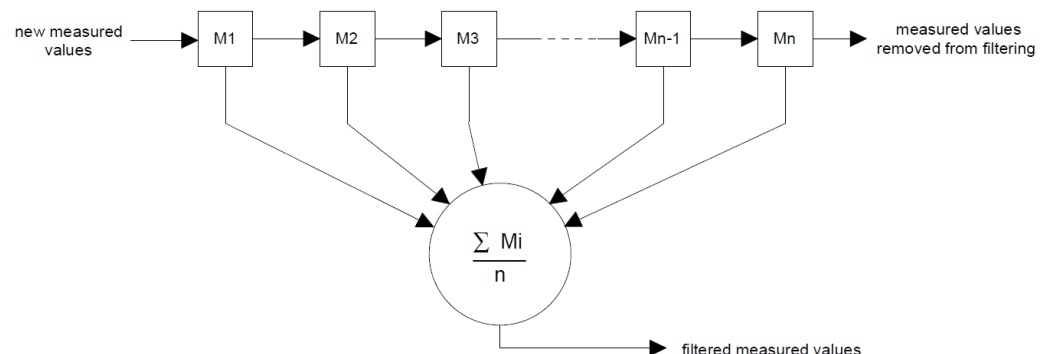

Figure 7-2: Averaging filter

Integration time

You can select the integration time of the A/D converters in the two measurement channels. This setting affects the stability of results at low powers (noise) and with low-frequency modulation of the envelope. The default setting of `FILT:INT:TIME` results in a suppression of low-frequency modulation, or to an integer multiple thereof as from 20 Hz and in optimum noise reduction.

- Forward average power and forward measured burst average measurements, `AVER`, `MBAV`:
For modulation frequencies below 20 Hz, increase the integration time to stabilize the displayed power. Ideally, set the integration time equal to the period of the envelope modulation. Low-frequency envelope modulation can also occur for digitally modulated radio signals, due to the so-called idle bursts which are regularly included in the transmitted signal.
- Triggered measurements:
You can increase the measurement speed by reducing the integration time if the averaging count remains unchanged. For automatic averaging, `FILT:AVER:MODE`, this condition is fulfilled only for sufficiently high powers. If an averaging filter is already active with the default integration time setting, a further reduction generally results in an automatic enhancement of the averaging count. So that on the whole, no gain in the measurement speed is achieved.

Video bandwidth

The video bandwidth defines the passband of the forward channel for the rectified signal. [Figure 7-3](#) shows the great influence on the time characteristic of the envelope signal and thus on the following measurements:

- Peak envelope power, `PEP`
- Crest factor, `CF`
- Complementary cumulative distribution function, `CCDF`
- Measured burst average, `MBAV`

Set the video bandwidth as small as possible to obtain stable results even at low forward powers (noise reduction). Not too small, however, because then significant distortion of the demodulated signal can result. As a rule of thumb, set the video bandwidth about 2 to 3 times the bandwidth of the measured signal at the RF. The rule of thumb does not apply to `MBAV` measurements.

[Figure 7-3](#) shows the influence of video bandwidth. The peak envelope power (PEP) is indicated as a dotted line.

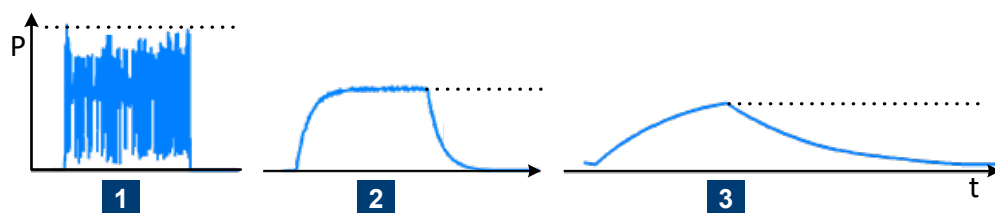

Figure 7-3: Influence of video bandwidth on rectified signal

1 = 4 MHz video bandwidth
 2 = 200 kHz video bandwidth
 3 = 4 kHz video bandwidth

Table 7-1 shows the bandwidth settings for several common waveforms. The settings allow transmission of the rectified signal that is largely free from distortion.

Table 7-1: Video bandwidth settings for common waveforms

Waveform		Video bandwidth setting, <code>FILT:VID</code>
AM	Mod. frequency \leq 1 kHz	4E3 (4 kHz)
AM	Mod. frequency \leq 50 kHz	2E5 (200 kHz)
CW burst	Burst width \geq 150 μ s	4E3 (4 kHz)
CW burst	Burst width \geq 3 μ s	2E5 (200 kHz)
CW burst	Burst width \geq 1.5 μ s	6E5 (600 kHz)**
CW burst	Burst width \geq 200 ns	4E6 (4 MHz)***
$\pi/4$ DQPSK	Symbol rate \leq 24 k/s	2E5 (200 kHz)
$\pi/4$ DQPSK	Symbol rate \leq 72 k/s	6E5 (600 kHz)**
$\pi/4$ DQPSK	Symbol rate \leq 200 k/s	4E6 (4 MHz)***
CDMA/WCDMA	Chip rate \leq 8.2 M/s	4E6 (4 MHz) ****
DAB/DVB-T	-----	4E6 (4 MHz) ****

*) You can increase the accuracy for digitally modulated signals by enabling the modulation correction, see Chapter 7.1.8, "MOD", on page 44.
 **) only R&S NRT-Z14
 ***) only R&S NRT-Z44

Remote commands

<code>FILT:AVER:COUN</code>	38
<code>FILT:AVER:MODE</code>	39
<code>FILT:INT:MODE</code>	39
<code>FILT:INT:TIME</code>	39
<code>FILT:RES</code>	40
<code>FILT:VID</code>	40

`FILT:AVER:COUN` <num>

Sets a fixed number of measured values that are averaged continuously. The setting applies to all measurement paths — forward average power, reverse average power, peak power and CCDF. See also "Averaging" on page 36.

If a valid value is sent, `FILT:AVER:MODE` is automatically set to `USER`.

Parameters:

<num>

A value of 1 means that no averaging takes place. Each measured value is output immediately.

Range: 1, 2, 4, 8, 16, 32, 64, 128, 256

RESET: 1

FILT: AVER: MODE <parameter>

Enables or disables automatic averaging. See also "[Averaging](#)" on page 36.

Parameters:

<parameter>

AUTO

Sets the count of the averaging filters as a function of the forward power, the test function, the integration time of the A/ D-converters and the selected resolution of results.

The resolution is set using [FILT: RES](#). It has the following effect on the automatically set averaging count. A small measured power combined with a high-resolution results in a high average count. Only a comparatively high measured power combined with a low-resolution results in non-averaged measured values. For further information on measurement speed, refer to the specifications document.

USER

Uses the average count set by [FILT: AVER: COUN](#).

RESET: AUTO

FILT: INT: MODE <parameter>

Enables or disables a fixed integration time setting. See also "[Integration time](#)" on page 37.

Parameters:

<parameter>

DEF

Uses the default integration time.

USER

Uses the value set by [FILT: INT: TIME](#).

RESET: DEF

FILT: INT: TIME <num>

Sets the integration time. See also "[Integration time](#)" on page 37.

If a valid value is sent, [FILT: INT: MODE](#) is automatically set to [USER](#).

Parameters:

<num>

Range: 5E-3 to 0.1111

RESET: 0.03667

Unit: s

FILT:RES <parameter>

Sets the number of significant digits for automatic averaging. Also enables automatic averaging; you do not need to send `FILT: AVER: MODE AUTO` in this case.

See also:

- `FILT: AVER: MODE`
- "Averaging" on page 36

Note: Measured values are output in a fixed number format that is not affected by the resolution. Non-significant digits are truncated by the base unit or the user program corresponding to the set resolution.

Parameters:

<parameter>	The average of forward power above 1 W is displayed as follows:
	HIGH 4.5 digits.
	LOW 3.5 digits.
	RESET: LOW

FILT:VID <num>

Sets the video bandwidth. See also "Video bandwidth" on page 37.

Parameters:

<num>	Range:
	R&S NRT-Z14: 4E3, 2E5, 6E5
	R&S NRT-Z44: 4E3, 2E5, 4E6
	RESET: 2E5
	Unit: Hz

7.1.7 FOR

This command sets the forward measurement. See also [Chapter 7.1.4, "DISP"](#), on page 34.

The forward measurement that is set by default is `AVER`.



For the `CCDF`, `CF`, `MBAV` and `PEP` measurements, connect the sensor for the forward power in the privileged direction to ensure that the corresponding measurement paths are at sufficient power.

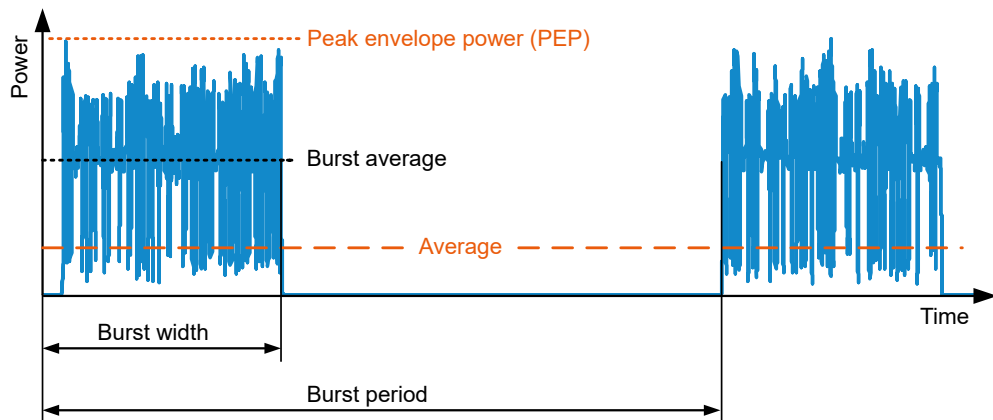

Figure 7-4: Forward power measurement parameters

FOR <parameter>

AVER

Sets the forward average power measurement.

This measurement provides the lowest measurement uncertainty and the widest measurement range. To keep the measurement accuracy specified in the specifications document, it is necessary to enter the carrier frequency using [FREQ](#).

You can increase the accuracy for digitally modulated signals by enabling the modulation correction, see [Chapter 7.1.8, "MOD"](#), on page 44.

CBAV

Sets the forward calculated burst average (CBAV) measurement.

This measurement determines the average power of modulated or unmodulated RF bursts, as shown in [Figure 7-4](#). The CBAV measurement result is calculated from the average power and the duty cycle.

Define the duty cycle using [BURS:WIDT](#) and [BURS:PER](#) on page 33.

You can increase the accuracy for digitally modulated signals by enabling the modulation correction, see [Chapter 7.1.8, "MOD"](#), on page 44.

For unmodulated bursts without envelope overshoot, the average burst power must be equal to the peak envelope power.

CCDF

Sets the complementary cumulative distribution function (CCDF) measurement.

This measurement determines the probability of the forward envelope power exceeding a preset threshold. It thus describes the amplitude distribution of the envelope.

Set the threshold using [CCDF](#).

Make sure that the video bandwidth is correct using `FILT:VID`.

You can increase the accuracy for digitally modulated signals by enabling the modulation correction, see [Chapter 7.1.8, "MOD"](#), on page 44.

[Figure 7-5](#) illustrates the CCDF measurement for an RF signal with a stochastic envelope. The thick lines in the right-hand graph indicate the time periods during which the envelope power exceeds the threshold. The percentage of these periods relative to the total measurement period equals the CCDF measurement result for the given threshold.

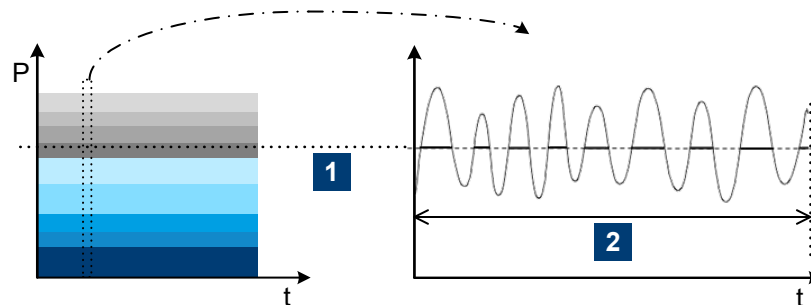

Figure 7-5: CCDF measurement shown for a test signal with a stochastic envelope

1 = CCDF threshold
2 = observation period

Example:

```

RESET
# Default setting.
@30 OK_____

FOR CCDF
# Sets CCDF measurement.
@60 old:AVER new:CCDF_____

CCDF 20
# Sets CCDF threshold to 20 W.
@55 old: 1.000000E+01 new: 2.000000E+01_____

RTRG
# Triggers the result.
@14 +2.4356E+01 +2.2345E+01 _icdr113300 _____
# The CCDF value is 24.356 %, the return loss 22.345 dB.

```

CF

Sets the crest factor (CF) measurement.

The crest factor is the ratio of peak envelope power (PEP) to average power. The crest factor provides information on the amount of modulation distortion and can assume high values for burst or spread spectrum signals, e.g. approx. 5 to 10 with CDMA.

Make sure that the video bandwidth is correct using `FILT:VID`.

Enable the modulation correction, see [Chapter 7.1.8, "MOD"](#), on page 44.

For further information on the correct setting of the sensor, see also [PEP](#).

MBAV

Sets the forward measured burst average measurement (MBAV: measured burst average).

The measured burst average is calculated from the average power and the duty cycle, see [Figure 7-4](#).

In contrast to the CBAV measurement, [CBAV](#), you do not need to define the duty cycle. The duty cycle is determined automatically by the sensor using the CCDF measurement, [CCDF](#), setting the CCDF threshold to half of the peak value for this process.

For modulated bursts, ensure the correct calculation of the duty cycle as follows. Set the video bandwidth narrow enough for the suppression of the modulation signal but still wide enough to prevent distortion of the rectangular envelope power characteristic. For an appropriate setting, see the middle graph of [Figure 7-3](#).

For CW bursts, select the video bandwidths as listed in [Table 7-1](#). Ensure the required measurement accuracy for the R&S NRT-Z44 as follows: duty cycle $\geq 10\%$, average burst power $\geq 2\text{ W}$.

You can increase the accuracy for digitally modulated signals by enabling the modulation correction, see [Chapter 7.1.8, "MOD"](#), on page 44.

PEP

Sets the continuous measurement of peak envelope power (PEP) of modulated signals and bursts.

While the output signal follows each increase in the envelope power directly, it responds to a decrease with a delay set by the [PEP](#) command group, see [Chapter 7.1.10, "PEP"](#), on page 46.

To obtain stable results, select the hold time longer than the interval between two consecutive peaks. The default setting of 60 ms allows measurements from modulation frequencies of about 20 Hz.

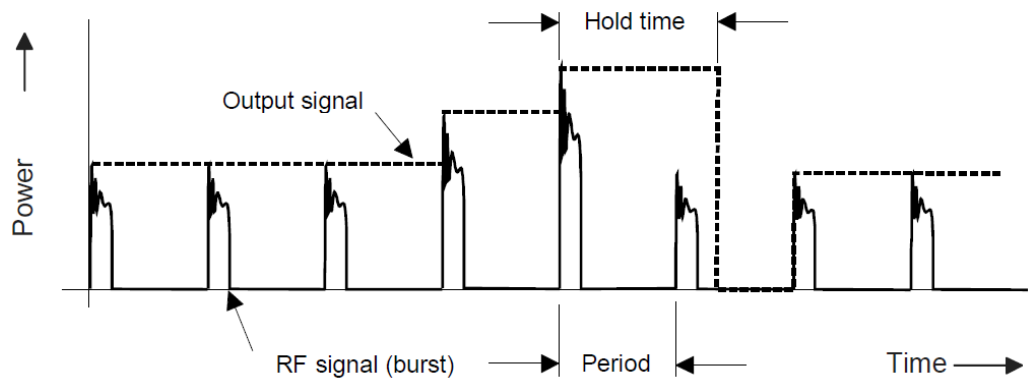

Figure 7-6: Output signal for peak envelope power (PEP)

The output signal is smoothed by digitization and subsequent averaging so that the actual fluctuation is much lower than shown in Figure 7-6.

If you do not want to blank unwanted components, select the video bandwidth corresponding to the highest frequency component of the envelope signal, see Table 7-1.

You can increase the accuracy for digitally modulated signals by enabling the modulation correction, see Chapter 7.1.8, "MOD", on page 44.

7.1.8 MOD

This command group is used for increasing the measurement accuracy for various digital communication standards.

The deviations that can be compensated are proportional to power for the average power and average burst measurements. Because they are only a few percent at nominal power, 120 W for R&S NRT-Z44, the modulation correction has practically no effect below approx. 10 W for R&S NRT-Z44.

To make sure that the modulation correction is enabled for the PEP, CF and CCDF measurements, set the R&S NRT-Z44 to full video bandwidth, using `FILT:VID 4E6`.

Systematic zero offsets of up to 1.5 W are normal for the PEP measurement at full video bandwidth and with modulation correction on. These offsets do not have any influence on the measurement accuracy in the specified power range.

Remote commands

<code>MOD:RATE</code>	44
<code>MOD:TYPE</code>	45

`MOD:RATE` <num>

Only available for the R&S NRT-Z44.

Sets the chip rate for the WCDMA communication standard.

Only effective if `MOD:TYPE WCDMA` is set.

Parameters:

<num> Range: 0 to 8.2E6
 RESET: 4.096E6
 Unit: per second

MOD:TYPE <parameter>

Sets a communication standard for the modulation correction to reduce systematic deviations occurring in power measurements.

The corrections always apply to the following measurements: forward average power [AVER](#), forward calculated burst average [CBAV](#), forward measured burst average [MBAV](#).

For the IS95, WCDMA, DVB-T and DAB communication standards, the corrections also apply to: complementary cumulative distribution function [CCDF](#), crest factor [CF](#), peak envelope power [PEP](#).

Spread spectrum signals that are not available as communication standards can be treated like WCDMA signals that are assigned a chip rate of 0.9 times the RF bandwidth.

Parameters:

<parameter>

OFF

Disabled

IS95

IS-95 CDMA standard for base stations

Only available for R&S NRT-Z44

WCDMA

WCDMA standard for base stations

Only available for R&S NRT-Z44

DVBT

DVB-T standard for terrestrial DVB TV transmitters

Only available for R&S NRT-Z44

DAB

DAB standard for radio transmitters.

Only available for R&S NRT-Z44

EDGE

Mobile communication standard

TETRA

Terrestrial trunked radio standard

Only available for R&S NRT-Z14.

RESET: OFF

7.1.9 OFFS

OFFS <num>

Considers the transmission loss in a cable that connects the desired measurement point, set by [PORT](#), and the sensor.

Depending on whether the cable is connected to the source or load port, the specified attenuation value has different effects on the measurement result. See "[Reference plane](#)" on page 47.

Parameters:

<num> Range: 0 to 100
 RESET: 0
 Unit: dB

7.1.10 PEP

This command group sets the hold time of the peak hold circuit.

Remote commands

PEP:HOLD	46
PEP:TIME	46

PEP:HOLD <parameter>

Enables or disables a fixed hold time.

Parameters:

<parameter> **DEF**
 Uses the default hold time.
 USER
 Uses the value set by [PEP:TIME](#).
 RESET: DEF

PEP:TIME <num>

Sets the hold time.

If a valid value is sent, [PEP:HOLD](#) is automatically set to **USER**.

Parameters:

<num> Range: 1E-3 to 1E-1
 RESET: 6E-2
 Unit: s

7.1.11 PORT

Reference plane

The measurement results are referred to the sensor port. This distinction is necessary to meet more stringent measurement accuracy requirements. The sensor absorbs part of the RF power and thus the outgoing waves from the sensor are reduced by the insertion loss in comparison with the incoming waves, see [Figure 7-7](#).

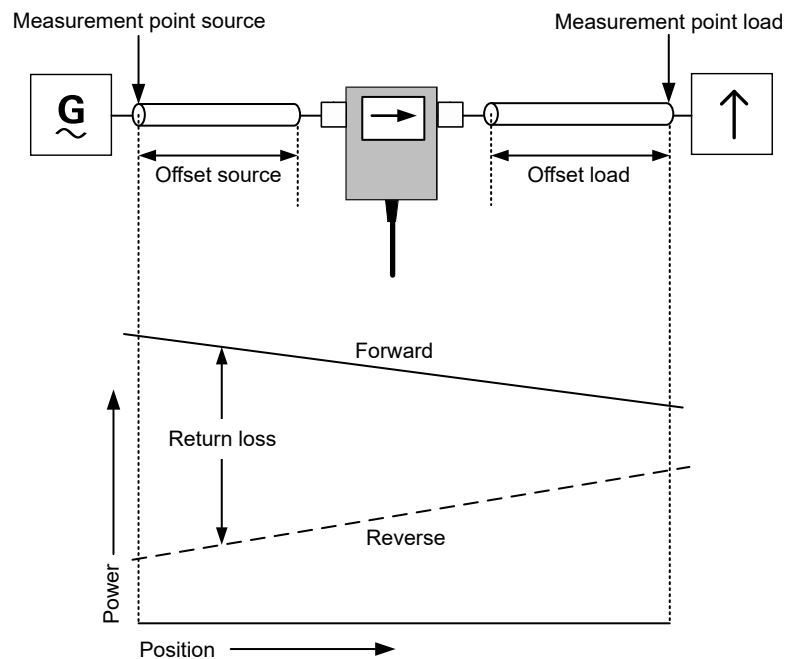

Figure 7-7: Definition of the test point

Depending on the desired measurement result, the measurement has to be carried out at the source or load. See [Table 7-2](#).

Table 7-2: Reference plane for the different measurement results

Measurement result	Sensor setting		Load matching
	Ref. plane	Measurement	
Active power provided by source	SOUR	AVER CBAV MBAV PEP	any
Active power absorbed by load	LOAD	$*(1 - (\text{REV RCO})^2)$	
Forward power (source)	SOUR	AVER CBAV MBAV	

Measurement result	Sensor setting		Load matching
	Ref. plane	Measurement	
Forward power (load)	LOAD	PEP	
Load matching	LOAD	RL RCO SWR	
Power of source into 50 Ω	SOUR	AVER	good (SWR < 1.2)

The maximum difference between the two measurement points is:

- R&S NRT-Z14: 0.017 dB at 1 GHz
- R&S NRT-Z44: 0.048 dB at 4 GHz

At some DUTs, the test point itself is not accessible, for example an output connector of a transmitter or an antenna input. In these cases, you can enter the attenuation of the cable that connects the sensor and the test point using **OFFS**. Using the reference plane and the attenuation, power and matching are corrected as if the measurement is carried out at the inaccessible test point.

Example: Measuring the output power of a transmitter

The sensor is connected to the transmitter output using a cable with an insertion loss of 0.45 dB.

The correct setting of the sensor is the reference plane **SOUR** with 0.45 dB attenuation. Without considering the attenuation, the measured output power of the transmitter would be 0.45 dB or 10 % too low.

Example: Measuring the matching of an antenna

The input of an antenna is connected to the sensor using a long cable with an insertion loss of 1.2 dB.

The correct setting of the sensor is the reference plane **LOAD** with 1.2 dB attenuation. Without considering the cable loss, the measured return loss of the antenna would be 2.4 dB too high.

PORT <parameter>

Selects the sensor port to which the measurement results are referred, see "[Reference plane](#)" on page 47.

Parameters:

<parameter>

SOUR

Source connector of the sensor, see [Figure 3-4](#).

LOAD

Load connector of the sensor, see [Figure 3-4](#).

RESET: LOAD

7.1.12 RESET

RESET

Sets the sensor to a defined initial state. The default settings are indicated in the description of commands as RESET value.

The default settings are not identical with the power-up status. On power-up, the settings from the last session are loaded.

7.1.13 REV

This command sets the reverse measurement.

The reverse measurement that is set by default is [RL](#).

REV <parameter>

POW

The effect of this command depends on the selected forward measurement. Except for the crest factor, peak envelope power and complementary cumulative distribution function measurements, the command measures the reverse power corresponding to the selected forward measurement, see [Table 7-3](#).

Table 7-3: Reverse power measurement

Forward measurement		Measured in reverse power measurement
forward average power	AVER	reverse average power
forward calculated burst average	CBAV	reverse calculated burst average
complementary cumulative distribution function	CCDF	forward average power
crest factor	CF	forward average power
forward measured burst average	MBAV	reverse measured burst average
peak envelope power	PEP	reverse average power *
* R&S Virtual NRT: If the PEP measurement is selected, "PWR" displays the maximum reverse PEP.		

RCO

Sets the reflection coefficient (RCO) measurement.

The reflection coefficient is defined as the ratio of reflected to incident wave. The values range from 0 for matching to 1 for total reflection.

The sensor calculates the reflection coefficient from the average values of the forward and the reverse power:

$$\text{Reflection coefficient} = \sqrt{\frac{\text{Reverse power}}{\text{Forward power}}}$$

RL

Sets the return loss (RL) measurement.

The return loss indicates the attenuation in dB of the reflected wave relative to the incident wave:

$$\text{Return loss} = 10 \times \log \frac{\text{Forward power}}{\text{Reverse power}}$$

SWR

Sets the standing wave ratio (SWR) measurement.

The standing wave ratio indicates the ratio of maximum to minimum voltage on an RF line:

$$\text{Standing wave ratio} = \frac{1 + \text{Reflection coefficient}}{1 - \text{Reflection coefficient}}$$

7.1.14 ZERO

Zeroing in the PEP measurement

For PEP measurement with active modulation correction, residual zero offsets of up to approx. 1.5 W are normal for the R&S NRT-Z44 after zeroing, see [Chapter 7.1.8, "MOD"](#), on page 44.

Example:

After successful zeroing, the sensor outputs the calculated offset values as follows. All values are in V, referred to detector output:

```
@DE pack 04 _____
@79 01 zero1 = +3.0047E-08, zero2 = -1.8586E-06_
```

Indicates the offsets for measurement of the average power in the forward (zero1) and reverse (zero2) measurement paths.

```
@28 02 PEP zero for 4kHz filter : -4.2817E-07_
@48 03 PEP zero for 200kHz filter : -5.2792E-05_
@03 04 PEP zero for 4MHz filter : -1.6621E-04_
```

These lines indicate the offset for the PEP function in the forward measurement path for various settings of the video filter.

ZERO <parameter>

Starts zeroing or disables the zero offset correction.

Zeroing removes offset voltages from the analog circuitry of the sensor, so that there are only low powers displayed when there is no power applied.

An active test signal during zeroing causes an error (`ERROR ZERO`), and the results are ignored. Therefore switch off the RF power during zeroing.

You can perform zeroing any number of times. Each new zeroing overwrites the results of the previous zero measurement.

Parameters:

<parameter>	<no parameter> Performs zeroing.
	0 Disables the zero offset correction; active on power-up.

7.2 Query commands

• FTRG	51
• QSTN	52
• RTRG	52
• SPEC	52
• STAT	56

7.2.1 FTRG

FTRG

Starts a continuous measurement at a high speed controlled by an internal timer, without any reference to an external trigger. Reads the last result.

The command has no effect on the internally controlled measurement processes. Measurements are started automatically on completion of a power-up or an external trigger, see [Chapter 7.2.3, "RTRG"](#), on page 52. The measurement speed depends on the measurement, but is not affected by the setting of the averaging filter, see ["Averaging"](#) on page 36.

Example:

```
RESET
# Resets the sensor.

FTRG
@2A +7.0392E-04 +1.2667E+01 __avr115500 _____
# Response:
# <forward power in W> <return loss in dB> <status field>
```

7.2.2 QSTN

QSTN

Queries the stock number.

Example:

QSTN

@2E 1444.0012.02 _____

The stock number is also included in the response of [SPEC](#).

7.2.3 RTRG

RTRG

Triggers a remote-controlled measurement.

The command interrupts the current, internally controlled measurement, starts a new measurement and outputs the result.

If averaging is enabled, a result is output only when averaging is completed, i.e. when the required number of measurements has been performed.

The results are read when the measured quantity remains constant after the command has been sent.

The measurement time depends on the measurement, the setting of the averaging filter, and the integration time of the A/D converters, see the specifications document. The output format corresponds to that of [FTRG](#).

7.2.4 SPEC

[Table 7-4](#) explains the meaning of the data read out from the sensor by [SPEC](#).

Table 7-4: Specifications

Line	Parameter	Meaning
1	ID:ID	Identification string, see ID on page 62.
2	ID:SER	Serial number
3	ID:CAL:REV	Version number of calibration program
4	ID:CAL:LAB	Calibration lab
5	ID:CAL:DAT	Calibration date
6	ID:CAL:SIGN	Name of person in charge
7	ID:STOCK	Stock no. of the sensor
8	TYPE	Sensor type
9	FREQ:RANG:LOW	Lower frequency limit
10	FREQ:RANG:UPP	Upper frequency limit

Line	Parameter	Meaning
11	FREQ:RANG:DEF	Default frequency
12	POW	Nominal power
13	IMP	Characteristic impedance
14	FORW:AVER:RANG:LOW	Lower measurement limit for average forward power in W, direction 1>2
15	FORW:AVER:RANG:UPP	Upper measurement limit for average forward power in W, direction 1>2
16	FORW:AVER:RANG:LSD	Least significant digit of measured value with decimal notation in W Example: -3 means that results are represented including the mW position.
17 - 20	FORW:MBAV:RANG:LOWn	Lower measurement limit for forward measured burst average n: coding of video bandwidth, see lines 60 to 64.
21	FORW:MBAV:RANG:UPP	Upper measurement limit for forward measured burst average
22 - 25	FORW:MBAV:RANG:LSDn	Least significant digit of measured value with decimal notation in W n: coding of video bandwidth, see lines 60 to 64.
26 - 29	FORW:CF:RANG:LSDn	Least significant digit of measured value with decimal notation in dB n: coding of video bandwidth, see lines 60 to 64.
30 - 38	FORW:PEP:RANG: to	PEP measurement limit; definition analog to FORW:MBAV:RANG
39	FORW:PEP:TIME:LOW	Minimum selectable hold time for PEP measurement
40	FORW:PEP:TIME:UPP	Maximum selectable hold time PEP measurement
41	FORW:PEP:TIME:DEF	Default hold time for PEP measurement
42 - 50	FORW:CCDF:RANG to	CCDF measurement limits; definition analog to FORW:MBAV:RANG
51 - 53	REFL:AVER:RANG to	Measurement limits for reverse power; definition analog to FORW:AVER:RANG
54	FILT:AVER:AUTO	Automatic averaging available
55	FILT:AVER:COUN:UPP	Maximum count of averaging filter
56	FILT:AVER:COUN:DEF	Default count of averaging filter
57	FILT:INT:TIME:LOW	Minimum integration time for A/D converters
58	FILT:INT:TIME:UPP	Maximum integration time for A/D converters
59	FILT:INT:TIME:DEF	Default integration time for A/D converters
60	FILT:VID:NRBW	Number of video filter settings

Line	Parameter	Meaning
61 - 64	FILT:VID:BWn	Video bandwidth for n th setting
65	MOD:TYPE:NRST	Number of communication standards with modulation correction, incl. OFF

SPEC

Reads all relevant data of the sensor. These data are used by the basic unit to perform sensor-specific scaling and to recognize the limit values of input parameters. See [Table 7-4](#).

Example:

```

SPEC
# Response: Multiple lines with the following structure:
@28 pack 72
@A4 01 ID:ID:Rohde & Schwarz NRT-Z43V1.40
@53 02 ID:SER
@61 03 ID:CAL:REV
@44 04 ID:CAL:LAB
@4F 05 ID:CAL:DAT
@A8 06 ID:CAL:SIGN
@4A 07 ID:STOCK 1081.2905.02
@C5 08 TYPE POWER DIRECTIONAL
@74 09 FREQ:RANG:LOW 400E6
@12 10 FREQ:RANG:UPP 4E9
@EA 11 FREQ:RANG:DEF 1E9
@FC 12 POW 30
@EF 13 IMP 50
@CE 14 FORW:AVER:RANG:LOW 0.007
@49 15 FORW:AVER:RANG:UPP 75
@2D 16 FORW:AVER:RANG:LSD -4
@98 17 FORW:MBAV:RANG:LOW1 0.5
@9A 18 FORW:MBAV:RANG:LOW2 0.5
@CF 19 FORW:MBAV:RANG:LOW3 1.25
@C8 20 FORW:MBAV:RANG:LOW4 1.25
@3E 21 FORW:MBAV:RANG:UPP 75
@52 22 FORW:MBAV:RANG:LSD1 -3
@54 23 FORW:MBAV:RANG:LSD2 -3
@56 24 FORW:MBAV:RANG:LSD3 -3
@58 25 FORW:MBAV:RANG:LSD4 -3
@B8 26 FORW:CF:RANG:LSD1 -2
@BA 27 FORW:CF:RANG:LSD2 -2
@BC 28 FORW:CF:RANG:LSD3 -2
@BE 29 FORW:CF:RANG:LSD4 -2
@4E 30 FORW:PEP:RANG:LOW1 0.1
@86 31 FORW:PEP:RANG:LOW2 0.25
@56 32 FORW:PEP:RANG:LOW3 0.5
@54 33 FORW:PEP:RANG:LOW4 1.0
@01 34 FORW:PEP:RANG:UPP 75
@15 35 FORW:PEP:RANG:LSD1 -3
@16 36 FORW:PEP:RANG:LSD2 -2
@18 37 FORW:PEP:RANG:LSD3 -2
@1A 38 FORW:PEP:RANG:LSD4 -2
@74 39 FORW:PEP:TIME:LOW 1E-3
@CF 40 FORW:PEP:TIME:UPP 100E-3
@7F 41 FORW:PEP:TIME:DEF 60E-3
@B2 42 FORW:CCDF:RANG:LOW1 0.25
@B4 43 FORW:CCDF:RANG:LOW2 0.25
@B6 44 FORW:CCDF:RANG:LOW3 0.25
@B8 45 FORW:CCDF:RANG:LOW4 0.25
@2F 46 FORW:CCDF:RANG:UPP 75
@42 47 FORW:CCDF:RANG:LSD1 -2

```

```

@44 48 FORW:CCDF:RANG:LSD2 -2
@46 49 FORW:CCDF:RANG:LSD3 -2
@3F 50 FORW:CCDF:RANG:LSD4 -2
@EA 51 REFL:AVER:RANG:LOW 0.0007
@35 52 REFL:AVER:RANG:UPP 75
@1A 53 REFL:AVER:RANG:LSD -5
@93 54 FILT:AVER:AUTO
@7C 55 FILT:AVER:COUN:UPP 256
@EB 56 FILT:AVER:COUN:DEF 1
@FF 57 FILT:INT:TIME:LOW 1.06E-3
@D1 58 FILT:INT:TIME:UPP 111E-3
@1D 59 FILT:INT:TIME:DEF 36.67E-3
@99 60 FILT:VID:NRBW 4
@58 61 FILT:VID:BW1 4kHz
@B8 62 FILT:VID:BW2 200kHz
@3E 63 FILT:VID:BW3 4MHz
@43 64 FILT:VID:BW4 SPSP
@BC 65 MOD:TYPE:NRST 4
@8E 66 MOD:TYPE:ST IS95, WCDMA, DVB-T,DAB, OFF
@4F 67 MOD:RATE:LOW 0
@36 68 MOD:RATE:UPP 8.2E6
@7A 69 MOD:RATE:DEF 4.096E6
@93 70 OFFS:RANG:LOW 0
@F8 71 OFFS:RANG:UPP 100
@72 72 OFFS:RANG:DEF 0

```

7.2.5 STAT

This command group represents the status reporting system, see [Chapter 8.4, "Status reporting system"](#), on page 72. It gives information about the sensor status including all current settings and all occurred errors.

After querying the errors, all temporary errors — mainly operating errors — are cleared, all permanent errors remain.

Remote commands

STAT:MEAS	56
STAT:ERR:TEXT	57
STAT:ERR:CODE	58
STAT:ERR:VALS	59

STAT:MEAS

Returns the sensor status. For each setting, the current value is output.

Example:

```

STAT:MEAS
# Response: Multiple lines with the following structure:
@26 pack 34
@04 01 Cal.mode lock:           ON
@CE 02 DMA mode:                OFF
@EE 03 Forward meas. func.:     AVER
@AC 04 Reverse meas. func.:     RCO
@84 05 Burst period:            1.0000E-01
@43 06 Burst width:            1.0000E-02
@01 07 PEP hold mode: DEF
@35 08 PEP hold time:           6.0000E-02
@93 09 CCDF threshold:         4.0000E+01
@C3 10 Average filt mode:       AUTO
@C3 10 Average filt mode:       AUTO
@DD 12 ADC integ. time mode:    USER
@47 13 ADC integration time:    3.6667E-02
@20 14 Video Bandwidth:        2.0000E+05
@75 15 Spread spectr.weight.    OFF
@A9 16 Correction Frequency     1.0000E+09
@F0 17 Forward display          ON
@C7 18 Reflection display       ON
@5E 19 State display            ON
@DE 20 Sign. chan. assignmnt    1>2
@40 21 Reference port           SOUR
@40 22 Display resolution       LOW
@3E 23 Modulation type          OFF
@54 24 Modulation rate          4.0960E+05
@62 25 Attenuation              1.0000E+00
@40 26 C eff1                   1.0000E-11
@48 27 C eff2                   7.0000E-11
@4E 28 Measured parameters:
@50 29 Average zero value ADC1: -3.3953E-06
@47 30 Average zero value ADC2: -2.5194E-06
@3A 31 PEP zero value for 4kHz:  +6.4601E-06
@56 32 PEP zero value for 200kHz: -3.2413E-05
@27 33 PEP zero value for 4MHz:  -1.5866E-04
@E2 34 Current temperature:     27.045

```

STAT:ERR:TEXT

Returns the error status as a plain text list. The following information is included:

- Status of the analog hardware (HW PARAMETERS)
- Results of other checks (PERMANENT ERRORS)
- Operating errors (OPERATION ERRORS)

Each check is evaluated as OK or ERROR.

See also [Chapter 8.4.2, "Error status"](#), on page 73.

Example:

```

STAT:ERR:TEXT
# Response: Multiple lines with the following structure.
# Example (DMA OFF):
@27 pack 26
@6E 01 HW PARAMETERS:
@07 02 SUPPLY VOLTAGE + (ANA) OK
@0C 03 SUPPLY VOLTAGE + (DIG) OK
@0B 04 SUPPLY VOLTAGE - (ANA) OK
@10 05 SUPPLY VOLTAGE - (DIG) OK
@1B 06 LOGIC SUPPLY          OK
@68 07 SENSOR SUPPLY        OK
@61 08 FORW. CONTROL VOLTAGE OK
@4D 09 REFL. CONTROL VOLTAGE OK
@6E 10 CCDF OUTPUT LOW      OK
@7D 11 CCDF OUTPUT HIGH     OK
@3B 12 CCDF MEDIUM THRESHOLD OK
@0C 13 TEMPERATURE          OK
@66 14 PERMANENT ERRORS:
@CF 15 COMMUNICATION ADC 1   OK
@D1 16 COMMUNICATION ADC 2   OK
@6B 17 PEP CIRCUIT OPERATION OK
@8D 18 FLASH READ           OK
@DD 19 FLASH WRITE          OK
@FD 20 CAL. VALUES CHECKSUM OK
@F5 21 CALIBRATION VALUES  OK
@6C 22 OPERATION ERRORS:
@D9 23 CALIBRATION LOCKED   OK
@37 24 SYNTAX                ERROR
@DE 25 RANGE                 ERROR
@E2 26 ZERO                  OK

```

STAT:ERR:CODE

Returns the error status as a single-line error code for fast evaluation.

Each error condition in [Table 8-1](#) is assigned 1 flag. The code starts with the highest flag no. on the left:

<flag no. 23>...<flag no. 1>

Erroneous parameters are indicated by 1, correct parameters by 0.

Example:

```

STAT:ERR:CODE
# For the example in STAT:ERR:TEXT, the response looks
# as follows:
@52 000000000000000000000000110
# For the flags with number 3 and 2, an error is present.

```

STAT:ERR:VALS

Gives details on the status of the analog hardware, listed in [STAT:ERR:TEXT](#) under HW PARAMETERS. Returns the internal test voltages together with their limit values.

Example:

```
STAT:ERR:VALS
@DD pack 12_____
@3D 01 SUPPLY VOLTAGE + (ANA) : +4.7500E+00 +5.0191E+00 +5.2500E+00
@47 02 SUPPLY VOLTAGE + (DIG) : +4.7500E+00 +5.0394E+00 +5.2500E+00
@45 03 SUPPLY VOLTAGE - (ANA) : -5.2500E+00 -5.0333E+00 -4.7500E+00
@53 04 SUPPLY VOLTAGE - (DIG) : -5.2500E+00 -5.0639E+00 -4.7500E+00
@4D 05 LOGIC SUPPLY : +3.1350E+00 +3.3130E+00 +3.4650E+00
@9E 06 SENSOR SUPPLY : +6.0000E+00 +1.1937E+01 +2.8500E+01
@A9 07 FORW. CONTROL VOLTAGE : -4.2500E+00 -6.9953E-02 +4.2500E+00
@89 08 REFL. CONTROL VOLTAGE : -4.2500E+00 -2.1738E-01 +4.2500E+00
@0E 09 CCDF OUTPUT LOW : -9.9987E-04 +9.6858E-05 +9.9987E-04
@C5 10 CCDF OUTPUT HIGH : +6.8000E-01 +7.5665E-01 +8.2000E-01
@6B 11 CCDF MEDIUM THRESHOLD : -1.3500E+00 -1.2364E+00 -1.1500E+00
@4B 12 TEMPERATURE : -1.5000E+01 +2.9497E+01 +6.5000E+01
```

7.3 General commands

APPL	59
BOOT	60
DMA	60
HELP	60
ID	62
PURGE	63
SETUP:SAVE	63
SETUP:RCL	63

APPL

Enables the measurement mode.

The response indicates the operating status of the sensor before the command was sent:

- boot
The sensor is in boot mode.
Active on power-up or on sending [BOOT](#). Prepares the sensor for loading new firmware.
- busy
The sensor is not ready to accept commands, e.g. during the power-up test.
- oper

The sensor is in its normal operating mode, the measurement mode. Enable the sensor by sending `APPL` at least once. See [Chapter 4.3.2.2, "Testing the connection"](#), on page 26.

BOOT

Enables the boot mode. No response is given.

The command has the same effect as switching off and on the supply voltage.

DMA <parameter>

Enables or disables filling up all response lines.

Parameters:

<parameter>

ON

Allows DMA-supported transfer to the controller.

All response lines have a uniform length of 50 characters, including the end-of-line characters CR and LF.

Shorter response lines are filled with '_' (ASCII 95/0x5F) between the message content and the end of the line.

OFF

The filling-up function is disabled, resulting in variable line length. This setting can be useful for time-critical applications (without DMA).

RESET: ON

HELP <parameter>

Returns a brief description of the specified commands.

Response: lists all specified commands.

Parameters:

<parameter>

<no parameter>

All root commands are listed.

<first letter of a command>

All commands starting with the letter are listed.

<root command>:HELP

All commands of this subsystem are listed.

Example:

```

HELP
# Lists all commands of the highest command level:
@DE pack 31_____
@E9 01 appl - operation mode ('boot' or 'oper')
@93 02 basever - base unit version control comm.
@4C 03 boot - soft reset_____
@37 04 burs - burst settings (burs:help)_____
@36 05 calib - calibration commands (calib:help)
@40 06 ccdf - CCDF threshold in W_____
@29 07 dir - meas. direction (1>2|2>1|AUTO)___
@77 08 disp - meas. display config. (disp:help)
@F3 09 dma - padding to 50 char. (ON|OFF)_____
@11 10 filt - filter settings (filt:help)_____
@80 11 for - forward meas. function (for:help)
@E0 12 freq - correction freq. in Hz_____
@3E 13 ftrg - free run trigger_____
@82 14 fwup - firmware update_____
@3E 15 help - this command_____
@7C 16 id - return firmware ID_____
@C0 17 mod - modulation type (mod:help)_____
@DD 18 offs - attenuation correction_____
@70 19 pep - PEP function settings (pep:help)_
@28 20 port - reference port (SOUR|LOAD|NONE)___
@A6 21 purge - purge receive buffer_____
@96 22 qstn - return stock number_____
@FE 23 reset - initialization of all parameters_
@97 24 rev - reverse meas. function (rev:help)
@80 25 rtrg - remote trigger_____
@27 26 serv - service commands (serv:help)_____
@A3 27 setup - sensor setups (setup:help)_____
@DA 28 spec - output parameter boundaries_____
@EC 29 stat - device state (stat:help)_____
@75 30 test - serial interface test_____
@B7 31 zero - initiate zero correction_____

```

Example:

```

HELP F
# Lists all root commands starting with an "F".
@DF pack 05_____
@11 01 filt - filter settings (filt:help)_____
@80 02 for - forward meas. function (for:help)
@E0 03 freq - correction freq. in Hz_____
@3E 04 ftrg - free run trigger_____
@82 05 fwup - firmware update_____

```

Example:

```
CALIB:HELP
# Lists all calibration commands.
@DF pack 05 _____
@11 01 filt - filter settings (filt:help)_____
@80 02 for - forward meas. function (for:help)_____
@E0 03 freq - correction freq. in Hz _____
@3E 04 ftrg - free run trigger _____
@82 05 fwup - firmware update _____
```

Example:

```
CALIB:HELP
@E4 pack 28 _____
@A7 01 acal - auto calibration of ADCs _____
@D5 02 calc - initiate calculation of cal. data _____
@A7 03 ccdf - CCDF calibration _____
@CC 04 err - calibration errors (calib:help)____
@96 05 fcorr1 - freq. correction constant _____
@98 06 fcorr2 - freq. correction constant _____
@76 07 freq1 - forward freq. cal. (# pow. freq.) _____
@7F 08 freq2 - reverse freq. cal. (# pow. freq.) _____
@41 09 help - this command _____
@BA 10 init - set all cal. values to default ____
@BA 11 kappa1 - constant in correction formula__
@BC 12 kappa2 - constant in correction formula__
@5A 13 lin1 - forward lin. cal. (# pow.) _____
@63 14 lin2 - reverse lin. cal. (# pow.) _____
@D1 15 lnfreq1 - index of forward ref. freq. ____
@DA 16 lnfreq2 - index of reverse ref. freq. ____
@37 17 load - load binary calibration data _____
@49 18 lock - lock calibration mode _____
@77 19 offs - internal offset _____
@C7 20 rcal - read ADC calibration values _____
@FF 21 read - read calibration data as text ____
@A7 22 rvid - measurement of video resistance__
@52 23 save - save binary calibration data _____
@7E 24 show - output calibration data as text__
@52 25 tcorr1 - forward temp. corr. constant ____
@5B 26 tcorr2 - reverse temp. corr. constant ____
@FD 27 trg - trigger for cal. measurement _____
@02 28 unlock - unlock cal. mode (keyword) _____
```

ID

Returns the identification string that is composed of the following items, separated by spaces:

- Name of the manufacturer, i.e. "Rohde&Schwarz"
- Sensor type
- Firmware version
- Firmware build date in ISO format (YYYY-MM-DD)

PURGE

Deletes the contents of the input buffer, thus preventing the execution of waiting commands. Useful to prepare the sensor quickly for a new measurement task.

No response is given.

SETUP:SAVE <num>

Saves the current sensor status in the specified intermediate memory.

Response: OK

Parameters:

<num> The status saved in memory no. 0 corresponds to the switch-on status.

Range: 0 to 4

SETUP:RCL <num>

Recalls the sensor status from the specified intermediate memory.

Parameters:

<num> The status saved in memory no. 0 corresponds to the switch-on status.

Range: 0 to 4

7.4 Self-test

See also [Chapter 9.3, "Self-test"](#), on page 77.

SERV:TEST

Performs a self-test and updates the error status.

You can read the error status using with the commands of the `STAT:ERR` group, see [Chapter 7.2.5, "STAT"](#), on page 56. An error is output only if a hardware error has occurred. Temporary errors, e.g. syntax or other input errors, are not considered.

Response: OK or ERROR

8 Remote control basics

• Device-dependent messages	64
• Hardware functions	70
• Command processing	71
• Status reporting system	72

8.1 Device-dependent messages

Messages from the sensor are called device-dependent messages. These messages are transmitted on the TXD and RXD pair of lines of the serial RS-422 interface. The ASCII code (ISO 7-bit code) is used. All device-dependent messages are line-oriented. A message line consists of several ASCII characters terminated by at least one end-of-line character.

A message sent to the sensor can be max. 255 characters long. Accepted end-of-line characters are all characters in the ASCII code range 1 to 13 (0x0D). The sensor terminates its responses with the character combination 13 (0x0D) + 10 (0x0A).

8.1.1 Structure and syntax of device-dependent messages

The command syntax was designed with a view to maximum speed rather than complete compliance with the SCPI standard. Device-dependent messages are divided as follows:

- Setting and query commands, see [Chapter 8.1.1, "Structure and syntax of device-dependent messages"](#), on page 64
- Device responses, see [Chapter 8.1.3, "Device responses"](#), on page 66

Messages belonging to commands are sent by the controller to the sensor. Device responses are sent from the sensor to the controller.

8.1.2 Setting commands and queries

The syntax has a tree structure with several hierarchical levels. Commands have different hierarchical levels depending on the expected frequency of application, the logic group assignment and the required speed of execution.

The number of mnemonics (keywords) that make up a command corresponds to the number of its hierarchical levels. The mnemonics of a command must be separated from one another by colons. Examples for typical structures of hierarchical commands:

- <system>:<subsystem>:<function>
- <system>:<function>

Each hierarchical level consists of two to five characters. Refer to the alphabetical list of all commands at the end of the user manual.

If an input parameter is added to a command, separate it from the command by at least one blank. Terminate a command with an end-of-line character. You can send several commands in a command line, but they must be separated by commas.

If a command is not understood, an error message is returned: `Error SYNTAX (xxxx) . xxxx` is the command or part of command that was not understood.

Example: Syntax errors

The setting command `FR:AVR` causes the following response:

```
@6C Error SYNTAX (fr:aver) _____
```

The command as a whole is not understood because the system mnemonic is erroneous, `FR` instead of `FOR`.

The setting command `FOR:AVR` causes the following response:

```
@71 Error SYNTAX (avr) _____
```

The function mnemonic is erroneous, `AVR` instead of `AVER`.

8.1.2.1 Parameters

Parameters can be floating-point numbers, integers and text. In the description of remote commands, numeric input parameters are represented by `<num>`, text parameters by `<parameter>`.

Floating-point numbers

Understood by the sensor in all common representations. You can omit leading zeros, positive signs of mantissas or exponents, and a decimal point at the rightmost digit of the mantissa.

Take the number 53 as an example. You can enter it in the following ways:

- 53
- 0.53e+2
- .5300e+02
- +005.3E01
- 5300e-002

An exponent has to start with the "E" or "e" character. The range of numbers is from -32000 to +32000. Exponents without mantissa are not allowed.

Integers

Depending on the range of values, they can have a positive or negative sign. You can omit the positive sign. If an integer parameter contains a character that does not belong to the character set [0 to 9, +, -], the character in question and all subsequent characters are ignored. No error message is output.

Input limits

Exist for all number parameters. If you try to enter a parameter outside the defined range of values, it is rejected with an error message: `Error RANGE`. Correct entries are acknowledged with:

```
old: <old parameter> new: <new parameter>
```

Except for `FOR` and `REV`. Here, correct entries are acknowledged with:

```
old:<old parameter> new:<new parameter>
```

Text parameters

Restricted to a few words like `USER`, `DEF`, `LOW`, `HIGH`. You can use uppercase or lower-case characters, but otherwise, you have to enter the text parameters exactly as they are specified in the command description.

8.1.3 Device responses

The sensor returns at least one line in response to each message. No response indicates a communication problem between the controller and the sensor.

Device responses are floating-point numbers, integers and text. The structure of device responses is explained in detail for each query command. All device responses have a header with a checksum, but single-line and multiple-line responses have different structures. The length of response lines is explained in [DMA](#) on page 60.

8.1.3.1 Checksum header

Placed at the beginning of each response line to enable the detection of transmission errors. The header starts with `@`, followed by the last two digits of the hexadecimal checksum and a blank:

```
@51 +8.1234E-02 +3.4567E-03 _____CRLF
```

The checksum is formed from the sum of all ASCII codes from the fifth character, modulo 256.

8.1.3.2 Status information

Consists of 11 characters and holds information on the validity of measured values. You can add the status field to the relevant device responses, see [DISP:STAT](#) on page 35.

First character

Indicates whether a hardware error is present.

- No error:
-
- Error:

e for error

Hardware errors are also detected in the self-test, see [Chapter 9.3, "Self-test"](#), on page 77.

Second character

Indicates whether the defined measurement limits are complied with.

- Values below the specified power range or outside the allowed temperature range:
i for invalid
- Values above the specified power range:
o for overrange
- All conditions are met:
–

Third and fourth characters

The third and fourth character of the status field

Indicate the test function of the forward channel, see [Chapter 7.1.7, "FOR"](#), on page 40.

- Average power (AVER):
av
- Distribution function (CCDF)
cd
- Crest factor (CF)
cf
- Calculated burst average (CBAV)
cb
- Measured burst average (MBAV)
mb
- Peak envelope power (PEP)
pp

Fifth and the sixth characters

Indicate the test function of the reverse channel, see [Chapter 7.1.13, "REV"](#), on page 49.

- Average power (POW)
pw
- Reflection coefficient (RCO)
rc
- Return loss (RL)
rl
- Standing wave ratio (SWR)
sw

Seventh character

Indicates the forward power direction, see [Chapter 7.1.3, "DIR"](#), on page 33.

- Privileged direction, source at port 1
1
- Inverse direction, source at port 2
2

Last four characters

Indicate the settings of the averaging filters for the physical measurement channel, see [Chapter 7.1.6, "FILT"](#), on page 36.

Possible values are 0 to 8, standing for the averaging counts from 2^0 (= 1) to 2^8 (= 256).

- Average power (forward):
7th character
- Average power (reverse):
8th character
- Peak envelope power:
9th character
- Distribution function:
10th character

Averaging is made over 2^N values. The exponent N (0 to 8) is output as an ASCII character for each measurement channel.

Example:

Device responses with the status field upon triggering a measured value:

```
DISP:STAT ON;FTRG
```

```
@2E +2.1234E+01 +3.4567E-03 __avpw15511 _____
```

The response is valid: no hardware error, no overrange or underrange. The returned values are the average powers in the forward and reverse channels. Averaging was made over $2^5 = 32$ values in each channel.

```
@32 +9.4823E+03 +5.9999E-03 e_mbrc12200 _____
```

The response is invalid since a hardware error is signaled.

```
@3C +3.5277E-04 +3.4567E-04 _ipprc22211 _____
```

The response is questionable since the peak envelope power specified in the specifications document is smaller than the returned value.

```
@15 +3.3244E+02 +1.2110E-01 _oavrc13300 _____
```

Overrange: The forward power exceeds the measurement range permitted in the specifications document.

8.1.3.3 Multiple-line responses

Some device responses take up several lines, e.g. the response to [SPEC](#). To detect transmission errors reliably and to make interpretation easier, multiple-line responses are output together with additional information.

In the first line of a multiple-line response, the keyword `pack xy` follows the checksum header. `xy` indicates the number of lines to be expected.

All subsequent response lines are numbered consecutively. The number follows the checksum header. The consecutive numbers help you to detect missing lines easily if transmission is disturbed.

Below is an example of multiple-line response with 'HH' standing for the checksum header and 'xxxxxx' representing the useful information:

Example:

"HH" stands for the checksum header, and "xxxxxx" for the delivered information.

```
@25 pack 06
@HH 01 xxxxxxx
@HH 02 xxxxxxx
@HH 03 xxxxxxx
@HH 04 xxxxxxx
@HH 05 xxxxxxx
@HH 06 xxxxxxx
```

8.1.3.4 Status messages

busy

If you send a command while the last command is still executed, the sensor ignores the new command and sends the following message:

```
@9B busy_____
```

This issue can occur with commands that require a long execution time. Wait and send the new command again.

Querying the sensor status

Send the `?` command.

The response depends on the operating mode of the sensor:

```
@A8 occupied_____
```

A measurement is running.

```
@76 idle_____
```

The sensor is waiting for new commands. If a new command is sent, the sensor executes it immediately.

8.2 Hardware functions

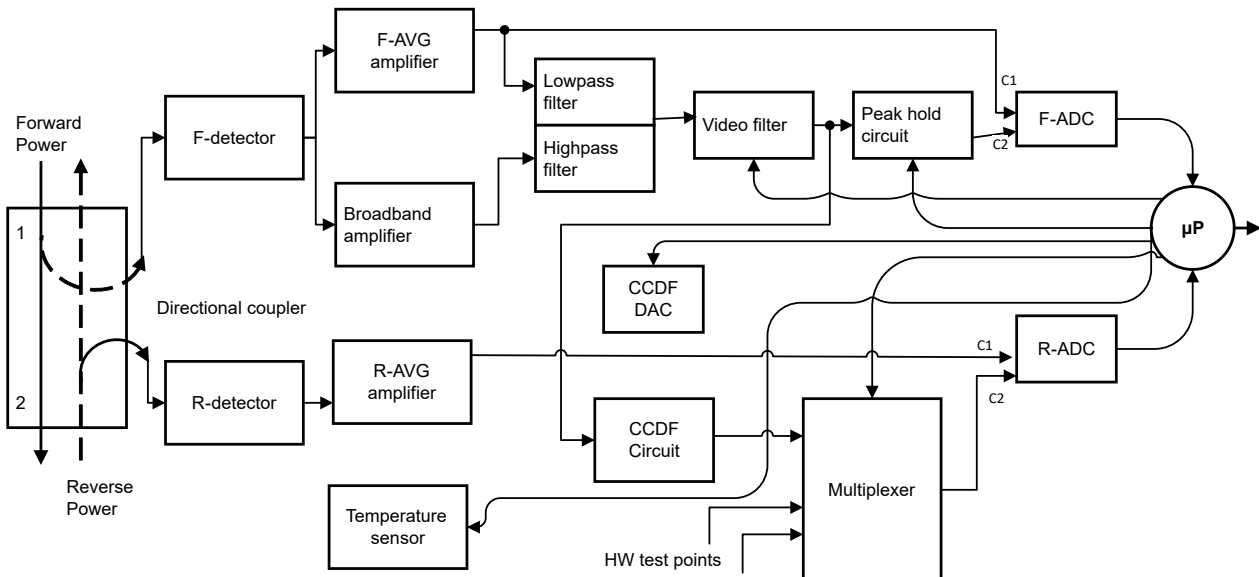

Figure 8-1: Hardware functions

The sensor is connected between the source and the load, see [Figure 3-1](#). Two RF signals are available at the outputs of the directional coupler. One RF signal is proportional to the forward wave from the source to the load. The other RF signal is proportional to the reflected wave from the load to the source. The output voltages of the two detectors follow the forward and reverse envelope powers. To measure the average power, the output voltages undergo narrowband amplification, F-AVG and R-AVG amplifiers, digitization and error compensation in the microprocessor. The error compensation is made with stored correction values, considering the temperature, frequency and linearity of the power sensor. From the ratio of the two average powers, the load matching can be determined in terms of return loss, SWR or reflection coefficient.

To measure the peak envelope power (PEP), the measured burst average (MBAV) and the complementary cumulative distribution function (CCDF), the output signal of the forward detector must undergo broadband processing. To this end, the outputs of the F-AVG amplifier and an AC coupled broadband amplifier are combined using a frequency filter. Unwanted signal components such as broadband noise or high-frequency modulation components are eliminated by a switchable video lowpass filter before further processing, see [FILT:VID](#).

The peak hold circuit delivers an output voltage corresponding to the peak envelope power of the forward signal. The CCDF circuit outputs a pulsed signal whose average value is proportional to the probability of the envelope power exceeding a given reference level, the CCDF threshold. The CCDF circuit is also used for measuring the average burst power, see [MBAV](#).

Digitization is performed by two highly linear $\Sigma\Delta$ A/D converters, F-ADC and R-ADC, with two measurement channels each. The preset measurement time of the two converters is 36.667 ms. You can change this time using `FILT:INT:TIME`. Further parameters such as temperature and various test voltages are measured during normal operation or in the self-tests by the multiplexer connected ahead of the reverse A/D converter.

8.3 Command processing

Figure 8-1 illustrates the physical and logic function blocks used for command processing. Commands are processed and executed from top to bottom.

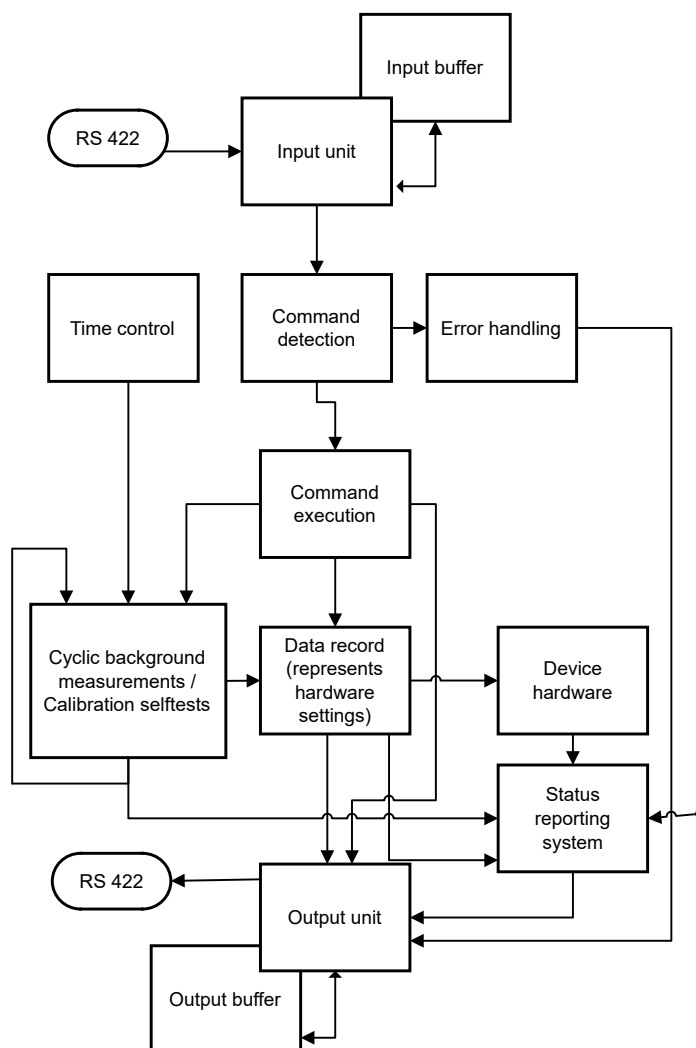

Figure 8-2: Command processing

The input unit receives the commands character by character via the serial interface and saves them in the input buffer. The input unit sends a message to the command detection circuit if the input buffer is full or a delimiter is received.

If the input buffer is full, bus traffic is stopped using the XON/XOFF protocol, and the data received up to this time are processed. Then, data traffic is resumed. If the buffer is not full, the input unit can receive the next command while the previous command is detected and executed.

The command detection circuit analyzes the data received from the input unit in the sequence of the data received. Each detected command is immediately passed on to command execution.

Syntax errors are passed on from the command detection circuit to the error handling unit. The rest of the command line is analyzed and processed as far as possible.

8.3.1 Device hardware and data record

Device hardware is the analog circuitry used for measuring. The controller is not part of the device hardware. The hardware settings are represented by the data record of the measurement program.

Setting commands generally cause a change of the data record and the device hardware. The data record management does not pass on any new values to the hardware until it is requested to do so by the command detection circuit.

8.3.2 Output unit

The output unit collects the information from the data record management, processes it in accordance with the rules described in [Chapter 8.1.3, "Device responses"](#), on page 66, and saves them in the output buffer. The output buffer has a capacity of 256 characters. If the requested information is longer than 256 characters, it is divided into several lines, see [Chapter 8.1.3.3, "Multiple-line responses"](#), on page 69.

8.3.3 Cyclic background power and temperature measurements

The cyclic background power and temperature measurements are performed independently from the interface data traffic. In the freerun trigger mode, `FTRG`, the background measurement continuously supplies measured power values and thus ensures a high refresh rate of the display. The background temperature measurement is performed once per second. The results are used for correcting the temperature response of the detectors.

8.4 Status reporting system

The status reporting system provides information on the sensor status. Two different statuses are distinguished.

8.4.1 Device status

The device status covers all parameters relating to measurements. It is output as a multiple-line response by `STAT:MEAS`. You can reset all these parameters to a defined initial status by `RESET`.

8.4.2 Error status

The error status is a report of occurred errors. You can output the error status either as a plain text multiple-line response or as code, see [Chapter 7.2.5, "STAT"](#), on page 56.

The errors are divided in two categories.

Temporary errors

For example a syntax error or a wrong range, see `OPERATION ERRORS` in [Table 8-1](#).

Buffer the temporary errors if you want to evaluate them.

Permanent errors

Hardware errors or errors that have occurred during calibration, see `HW PARAMETERS` and `PERMANENT ERRORS` in [Table 8-1](#).



Permanent errors remain until their cause is eliminated and can only be fixed by service personnel authorized by Rohde & Schwarz. See [Chapter 9.4, "Contacting customer support"](#), on page 79.

Error status overview

[Table 8-1](#) gives an overview of all errors that can occur. The flag number indicates the position of an error within the code, see `STAT:ERR:CODE`. The error description is identical with the multiple-line response obtained as response to `STAT:ERR:TEXT`.

Table 8-1: Error status overview

Position (from right)	Error description	Cause
HW PARAMETERS, see also Chapter 8.4.2.1, "Hardware parameter errors" , on page 74.		
23	SUPPLY VOLTAGE + (ANA)	ERROR +5 V on analog board not present or out of tolerance
22	SUPPLY VOLTAGE + (DIG)	ERROR +5 V on digital board not present or out of tolerance
21	SUPPLY VOLTAGE - (ANA)	ERROR -5 V on analog board not present or out of tolerance
20	SUPPLY VOLTAGE - (DIG)	ERROR -5 V on digital board not present or out of tolerance
19	LOGIC SUPPLY	ERROR +3.3 V on analog board not present or out of tolerance
18	SENSOR SUPPLY	ERROR Sensor supply out of tolerance
17	FORW. CONTROL VOLTAGE	ERROR Offset control voltage for forward amplifier (test point K603:13) out of tolerance

Position (from right)	Error description		Cause
16	REFL. CONTROL VOLTAGE	ERROR	Offset control voltage for reflection amplifier (test point K603:14) out of tolerance
15	CCDF OUTPUT LOW	ERROR	Min. settable CCDF threshold voltage out of tolerance
14	CCDF OUTPUT HIGH	ERROR	Max. settable CCDF threshold voltage out of tolerance
13	CCDF MEDIUM THRESHOLD	ERROR	Average CCDF threshold voltage (test point K603:12) out of tolerance
12	TEMPERATURE	ERROR	Temperature reading out of tolerance
PERMANENT ERRORS, see also Chapter 8.4.2.2, "Permanent errors" , on page 75.			
11	COMMUNICATION ADC 1	ERROR	Communication error between A/D converter in forward channel (T604) and processor
10	COMMUNICATION ADC 2	ERROR	Communication error between A/D converter in reverse channel (T605) and processor
9	PEP CIRCUIT OPERATION	ERROR	Fault in peak hold circuit (T609, V606, T608)
8	FLASH READ	ERROR	Fault when reading calibration data from Flash memory
7	FLASH WRITE	ERROR	Fault when writing calibration data to Flash memory
6	CAL. VALUES CHECKSUM	ERROR	Checksum test of the calibration data set failed.
5	CALIBRATION VALUES	ERROR	Calibration fault or calibration value out of tolerance. For further information, use <code>CALIB:ERR:TEXT</code> or <code>CALIB:ERR:CODE</code> .
OPERATION ERRORS			
4	CALIBRATION LOCKED	ERROR	A calibration function has been called without unlocking calibration mode using <code>CALIB:UNLOCK PASSWORD</code> .
3	SYNTAX	ERROR	Faulty input
2	RANGE	ERROR	A numerical parameter exceeds its limits.
1	ZERO	ERROR	Zeroing failed due to RF power applied.

8.4.2.1 Hardware parameter errors

Information for service personnel authorized by Rohde & Schwarz.

Error flags no. 12 to 23

All hardware parameters are measured upon power-up of the sensor and upon starting a self-test, see `SERV:TEST`. These errors can be output as voltage values together with their tolerances, see `STAT:ERR:VALS`.

Possible causes:

- The sensor hardware is faulty.
- The supply voltage of the sensor is low.

8.4.2.2 Permanent errors

Information for service personnel authorized by Rohde & Schwarz.

Error flags no. 10 and 11

Occurrence: At any time. The errors are immediately written into the error status report.

Error cause: The sensor hardware is faulty.

Error flag no. 9

Occurrence: Only during a triggered measurement in the PEP, MBAV and CF measurements.

Error cause: The sensor hardware is faulty.

Error flag no. 8

Occurrence: Only upon power-up and together with error flag no. 6 or a loss of calibration data.

Error cause: Flash memory is defective.

Error flag no. 7

Occurrence: Only when leaving the calibration mode. With successful calibration, the calibration data are written into Flash memory upon leaving the calibration mode.

Possible causes:

- Flash memory is defective.
- A power supply fault has occurred while data were being written into Flash memory.

Error flag no. 6

Occurrence: Only upon power-up.

Possible causes:

- The sensor is not calibrated yet.
- Flash memory is defective.
- A power supply fault has occurred while data were being written into Flash memory.

Error flag no. 5

Represents the sum of all faults that can occur in calibration. Error flag no. 5 is set if at least one calibration parameter is out of tolerance.

To make troubleshooting easier, saving erroneous calibration data into Flash memory is not disabled.

Error flag no. 5 remains set until the supply voltage is switched off.

Further information

- [Chapter 9, "Troubleshooting"](#), on page 77

9 Troubleshooting

Before starting measurement operation, wait until the instruments have warmed up.

9.1 Test setup

See [Chapter 3.1.5, "Connecting to a computer or base unit"](#), on page 15.

9.2 Power-up self-test

The R&S NRT-Zxx directional sensors perform an automatic test of several hardware parameters after power-up.

Using remote control

The result of the power-up test is recorded as error status, see [Chapter 8.4.2, "Error status"](#), on page 73.

► Send one of the following commands:

- `STAT:ERR:CODE`
- `STAT:ERR:TEXT`



The error status is also coded in the status field of a device response, see [Chapter 8.1.3, "Device responses"](#), on page 66.

If you use R&S Virtual NRT, you can display the status field permanently: "Options" > "State Indicator".

Using a base unit

Errors in the power-up test are indicated in the notification center of the base unit. See the user manual of the base unit for details.

If the errors are grave, the R&S NRT-Zxx is not recognized by the base unit.

9.3 Self-test

The self-test gives you detailed information that you can use for troubleshooting. For example, it helps you to detect hardware problems. If a hardware problem occurs, contact Rohde & Schwarz customer service, see [Chapter 9.4, "Contacting customer support"](#), on page 79.

Using the user interface of R&S Virtual NRT

► Select "Sensor" > "Selftest".

If all error state parameters are marked as "OK", the self-test is passed successfully.

Using a base unit

You can perform a self-test of a connected sensor using manual operation or remote control. See the user manual of the base unit for details.

Using remote control

1. Send `SERV:TEST`.
2. Read the error status by using `STAT:ERR:CODE` or `STAT:ERR:TEXT`.

Using a terminal program

- ▶ Send `SERV:TEST` to start a self-test.

Responses (examples):

- @30 OK _____
Self-test passed.
- @03 ERROR _____
Self-test failed.

- ▶ Send `STAT:ERR:CODE` to query the error code.

Responses (examples):

- @1B 00000000000000000000000000000000 _____
No error.
- @1D 01100000000000000000000000000000 _____
Error: The negative supply voltage is faulty.
For a reference on the error codes and error texts, see [Table 8-1](#).

- ▶ Send `STAT:ERR:TEXT` to query the error text.

Example: The negative supply voltage is faulty. The following text is returned:

```
@E2 pack 26 _____
@73 01 HW PARAMETERS: _____
@98 02 SUPPLY VOLTAGE + (ANA) OK _____
@9D 03 SUPPLY VOLTAGE + (DIG) OK _____
@6F 04 SUPPLY VOLTAGE - (ANA) ERROR _____
@74 05 SUPPLY VOLTAGE - (DIG) ERROR _____
@AC 06 LOGIC SUPPLY OK _____
@F9 07 SENSOR SUPPLY OK _____
@F2 08 FORW. CONTROL VOLTAGE OK _____
@DE 09 REFL. CONTROL VOLTAGE OK _____
@FF 10 CCDF OUTPUT LOW OK _____
@0E 11 CCDF OUTPUT HIGH OK _____
@CC 12 CCDF MEDIUM THRESHOLD OK _____
@9D 13 TEMPERATURE OK _____
@4E 14 PERMANENT ERRORS: _____
@60 15 COMMUNICATION ADC 1 OK _____
```

@62	16	COMMUNICATION ADC 2	OK	_____
@FC	17	PEP CIRCUIT OPERATION	OK	_____
@1E	18	FLASH READ	OK	_____
@6E	19	FLASH WRITE	OK	_____
@8E	20	CAL. VALUES CHECKSUM	OK	_____
@86	21	CALIBRATION VALUES	OK	_____
@54	22	OPERATION ERRORS:		_____
@6A	23	CALIBRATION LOCKED	OK	_____
@D8	24	SYNTAX	OK	_____
@7F	25	RANGE	OK	_____
@73	26	ZERO	OK	_____

If you need to transport or ship the product, see [Chapter 11, "Transporting"](#), on page 88.

9.4 Contacting customer support

Technical support – where and when you need it

For quick, expert help with any Rohde & Schwarz product, contact our customer support center. A team of highly qualified engineers provides support and works with you to find a solution to your query on any aspect of the operation, programming or applications of Rohde & Schwarz products.

Contact information

Contact our customer support center at www.rohde-schwarz.com/support, or follow this QR code:



Figure 9-1: QR code to the Rohde & Schwarz support page

10 Testing the rated specifications

Checking the specifications for the measurement uncertainties given in the specifications document requires an extensive test equipment. The more simple test setups described here are suitable replacements for troubleshooting but have higher measurement uncertainties.

10.1 Test equipment

Table 10-1: Required test equipment

Item no.	Instrument characteristics	R&S type	Stock No.
1	Power reflection meter	R&S NRT2	1424.7005.02
	Computer with R&S Virtual NRT installed and R&S NRT-Z5 USB interface adapter installed (discontinued R&S NRT-Z3 and R&S NRT-Z4 interface adapters are still supported)	R&S Virtual NRT	
2	Signal generator R&S NRT-Z44: 400 MHz to 4 GHz R&S NRT-Z14: 25 MHz to 1 GHz		
3	Power amplifier R&S NRT-Z44: 400 MHz to 4 GHz R&S NRT-Z14: 25 MHz to 1 GHz Output power > 5 W Gain > 25 dB Harmonic suppression > 25 dB		
4	Reference sensor R&S NRT-Z44: 0.4 GHz to 4 GHz R&S NRT-Z14: 25 MHz to 1 GHz 15 W or 30 W	R&S NRP18S-20 R&S NRP18S-25 R&S NRP-ZK6 cable R&S NRP-ZK8 cable	1424.6738.02 1424.6744.02 1419.0664.02 1424.9408.02
5	Reference power meter	R&S NRX	1424.7005.02

10.2 Test setup

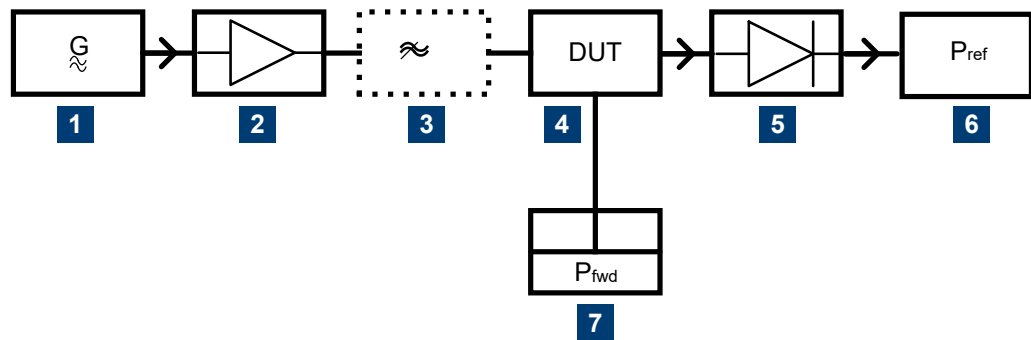

Figure 10-1: Test setup

- 1 = signal generator, see (2) in [Table 10-1](#)
- 2 = power amplifier, see (3) in [Table 10-1](#)
- 3 = harmonic filter
- 4 = DUT
- 5 = reference sensor, see (4) in [Table 10-1](#)
- 6 = reference power meter, see (5) in [Table 10-1](#)
- 7 = power reflection meter, see (1) in [Table 10-1](#)

10.3 Test sequences

Wait with the test power switched off until the instruments have warmed up.

Connect the device under test (DUT) and the reference power meter directly, because connection cables produce errors in measurement due to their attenuation and reflection. If adapters are required between RF connectors, use precision adapters with low attenuation and reflection.

The power measured in the following tests using one of the R&S NRT-Zxx directional sensors is the power coming out of the sensor. Therefore, set the offset reference plane of the power reflection meter to load.

Checking the specifications for the measurement uncertainties given in the specifications document requires an extensive test equipment. The test setups described here are simpler and have higher measurement uncertainties. The limit values specified in [Chapter 10.4, "Performance test report"](#), on page 85 consider these additional measurement uncertainties.

10.3.1 Testing the AVG measurement

Test setup see [Figure 10-1](#). Use a harmonic filter if the harmonic suppression of the amplifier is < 25 dB.

To perform the test

Perform the test sequence for both directions of the sensor.

1. Signal generator:
 - a) Switch off the output power.
 - b) Set the test frequency according to [Chapter 10.4, "Performance test report"](#), on page 85.
2. Power reflection meter:
 - a) Select the forward average measurement.
 - b) Set the offset reference plane to load.
 - c) Select automatic determination of the power flow direction.
 - d) Enter the test frequency.
 - e) Perform zeroing.
3. Reference power meter:
 - a) Enter the test frequency.
 - b) Activate frequency response correction.
 - c) Perform zeroing.
4. Signal generator:
 - a) Switch on the output power (test signal not modulated).
 - b) Set the level so that the reference power meter measures approx. 4 W power.
5. Calculate the power deviation of the DUT according to the following formula:
$$F_P = 100 \% \cdot [(P_{\text{fwd}} / P_{\text{ref}}) - 1]$$
6. Repeat the test sequence in a reverse measurement. In [step 2](#), select the reverse average measurement.
7. Calculate the power deviation for the reverse direction.

Compare the result with [Chapter 10.4, "Performance test report"](#), on page 85.

10.3.2 Testing the CCDF threshold

Test setup see [Figure 10-1](#).

To perform the test

1. Signal generator: Switch off the output power.
2. Perform zeroing of:
 - a) Sensor using the R&S NRT2 or R&S Virtual NRT.
 - b) Reference power meter
3. Enter the test frequency of 1 GHz on:
 - a) Signal generator
 - b) Power reflection meter

- c) Reference power meter
4. Reference power meter: Activate frequency response correction.
5. Signal generator:
 - a) Switch on the output power (test signal not modulated).
 - b) Set the level so that the reference power meter measures 3.8 W to 4.2 W power.
6. Select at the power reflection meter:
 - a) CCDF measurement
 - b) CCDF threshold 3 W
 - c) Video bandwidth 4 kHz
7. Read the CCDF value.
8. Compare the result with [Chapter 10.4, "Performance test report"](#), on page 85.
9. Select at the power reflection meter:
 - a) CCDF measurement
 - b) CCDF threshold 5 W
 - c) Video bandwidth 4 kHz
10. Read the CCDF value.
11. Compare the result with [Chapter 10.4, "Performance test report"](#), on page 85.

10.3.3 Testing the PEP measurement

Test setup see [Figure 10-1](#).

The PEP function is checked with the CF power indication.

To perform the test

1. Signal generator: Switch off the output power.
2. Perform zeroing of:
 - a) Sensor using the R&S NRT2 or R&S Virtual NRT.
 - b) Reference power meter
3. Enter the test frequency of 1 GHz on:
 - a) Signal generator
 - b) Power reflection meter
 - c) Reference power meter
4. Reference power meter: Activate frequency response correction.
5. Select at the power reflection meter:
 - a) Crest factor (CF) measurement.
 - b) Video bandwidth 4 kHz

6. Signal generator:
 - a) Switch on the output power (test signal not modulated).
 - b) Set the level so that the reference power meter measures 0.975 W to 1.025 W power.
 - c) Set 80 % AM modulation.
 - d) Modulation frequency 0.4 kHz.
7. Read the CF value.
8. Compare the result with [Chapter 10.4, "Performance test report"](#), on page 85.

10.3.4 Testing the directivity

Test setup see [Figure 10-1](#).

The directivity is calculated from the ratio of forward and reverse power with 50 V termination of the DUT. The return loss measurement of the power reflection meter provides this value.

To perform the test

1. Select at the power reflection meter:
 - a) Forward average measurement
 - b) Reflection return loss
 - c) High resolution
2. Connect the signal generator to port 1 of the DUT and the reference power sensor to port 2.
3. Power reflection meter:
 - a) Set the offset reference plane to load.
 - b) Select automatic determination of the power flow direction.
4. Signal generator:
 - a) Switch off the output power.
 - b) Set the test frequency according to [Chapter 10.4, "Performance test report"](#), on page 85.
5. Perform zeroing of the sensor using the power reflection meter.
6. Signal generator: Switch on the output power (test signal not modulated).
7. Record the directivity (return loss).

10.3.5 Testing the matching

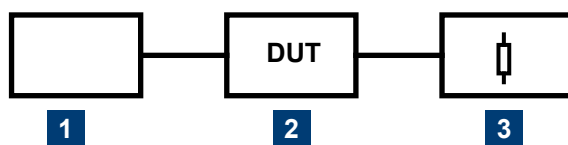

Figure 10-2: Test setup for testing the matching

- 1 = reflection test system
2 = device under test
3 = precision 50 Ω termination

To perform the test

Perform the test sequence for both directions of the sensor.

1. Measure the reflection coefficients s_{11} and s_{22} of the sensor.
2. Frequency range depends on the sensor:
 - R&S NRT-Z44: 400 MHz to 4 GHz
 - R&S NRT-Z14: 25 MHz to 1 GHz
3. Record the maximum values for the specified frequency ranges.
4. Repeat the sequence for the other direction.

10.4 Performance test report

You can print the performance test reports and fill in your test results.

Table 10-2: R&S NRT-Z14 test report

No.	Characteristic	Min.	Act. 1 → 2	Act. 2 → 1	Max.	Unit
1	AVG measurement, see 10.3.1					
	27.5 MHz	-4.6 (-0.20)			+4.6 (+0.20)	% (dB)
	32.5 MHz	-4.6 (-0.20)			+4.6 (+0.20)	% (dB)
	37.5 MHz	-4.6 (-0.20)			+4.6 (+0.20)	% (dB)
	45 MHz	-3.9 (-0.17)			+3.9 (+0.17)	% (dB)
	60 MHz	-3.9 (-0.17)			+3.9 (+0.17)	% (dB)
	85 MHz	-3.9 (-0.17)			+3.9 (+0.17)	% (dB)
	150 MHz	-3.9 (-0.17)			+3.9 (+0.17)	% (dB)
	250 MHz	-3.9 (-0.17)			+3.9 (+0.17)	% (dB)
	350 MHz	-3.9 (-0.17)			+3.9 (+0.17)	% (dB)
	450 MHz	-3.9 (-0.17)			+3.9 (+0.17)	% (dB)
	550 MHz	-3.9 (-0.17)			+3.9 (+0.17)	% (dB)
	650 MHz	-3.9 (-0.17)			+3.9 (+0.17)	% (dB)
	750 MHz	-3.9 (-0.17)			+3.9 (+0.17)	% (dB)
	850 MHz	-3.9 (-0.17)			+3.9 (+0.17)	% (dB)
	950 MHz	-3.9 (-0.17)			+3.9 (+0.17)	% (dB)
	1000 MHz	-3.9 (-0.17)			+3.9 (+0.17)	% (dB)
2	CCDF ratio with 3 W, see 10.3.2	100				%
	CCDF ratio with 5 W, see 10.3.2				0	%
3	Peak power measurement (CF value), see 10.3.3	3.53		---	4.27	dB
4	Directivity, see 10.3.4					
	25 MHz	21.5				dB
	50 MHz	21.5				dB
	100 MHz	21.5				dB
	200 MHz	21.5				dB
	400 MHz	21.5				dB
	600 MHz	21.5				dB
	800 MHz	21.5				dB
	1000 MHz	21.5				dB
5	Matching (Reflection coeff. s11, s22), see 10.3.5					
	25 MHz to 1000 MHz				0.05	

Table 10-3: R&S NRT-Z44 test report

No.	Characteristic	Min.	Act. 1 → 2	Act. 2 → 1	Max.	Unit
1	AVG measurement, see 10.3.1					
	0.22 GHz	-4.6 (-0.20)			+4.6 (+0.20)	% (dB)
	0.32 GHz	-3.9 (-0.17)			+3.9 (+0.17)	% (dB)
	0.39 GHz	-3.9 (-0.17)			+3.9 (+0.17)	% (dB)
	0.50 GHz	-3.9 (-0.17)			+3.9 (+0.17)	% (dB)
	0.63 GHz	-3.9 (-0.17)			+3.9 (+0.17)	% (dB)
	0.83 GHz	-3.9 (-0.17)			+3.9 (+0.17)	% (dB)
	1.00 GHz	-3.9 (-0.17)			+3.9 (+0.17)	% (dB)
	1.25 GHz	-3.9 (-0.17)			+3.9 (+0.17)	% (dB)
	1.75 GHz	-3.9 (-0.17)			+3.9 (+0.17)	% (dB)
	2.15 GHz	-4.2 (-0.18)			+4.2 (+0.18)	% (dB)
	2.50 GHz	-4.2 (-0.18)			+4.2 (+0.18)	% (dB)
	2.85 GHz	-4.2 (-0.18)			+4.2 (+0.18)	% (dB)
	3.15 GHz	-4.3 (-0.19)			+4.3 (+0.19)	% (dB)
	3.50 GHz	-4.3 (-0.19)			+4.3 (+0.19)	% (dB)
	3.85 GHz	-4.3 (-0.19)			+4.3 (+0.19)	% (dB)
	4.00 GHz	-4.3 (-0.19)			+4.3 (+0.19)	% (dB)
2	CCDF ratio with 3 W, see 10.3.2	100				%
	CCDF ratio with 5 W, see 10.3.2				0	%
3	Peak power measurement (CF value), see 10.3.3	3.53		---	4.27	dB
4	Directivity, see 10.3.4					
	0.4 GHz	21.5				dB
	0.9 GHz	21.5				dB
	1.3 GHz	21.5				dB
	1.8 GHz	21.5				dB
	2.4 GHz	17.7				dB
	3.0 GHz	17.7				dB
	3.5 GHz	16.5				dB
	4.0 GHz	16.5				dB
5	Matching (Reflection coeff. s11, s22), see 10.3.5					
	0.4 GHz to 3 GHz				0.06	
	> 3 GHz to 4 GHz				0.08	

11 Transporting

Packing

Use the original packaging material. It consists of antistatic wrap for electrostatic protection and packing material designed for the product.

If you do not have the original packaging, use similar materials that provide the same level of protection. You can also contact your local Rohde & Schwarz service center for advice.

Securing

When moving the product in a vehicle or using transporting equipment, make sure that the product is properly secured. Only use items intended for securing objects.

Transport altitude

The maximum transport altitude without pressure compensation is specified in the specifications document.

12 Maintenance, storage and disposal

The product does not require regular maintenance. It only requires occasional cleaning. It is however advisable to check the nominal data from time to time.

12.1 Checking and setting the baud rate

This task requires the removal of the plastic housing. Proceed exactly as described and leave the sealed metal casing closed. If you open the casing, the calibration is void and you have to send the R&S NRT-Zxx to the R&S service.

The factory-set value is 38400 Bd. This setting is compatible with the basic units. If necessary, you can change the baud rate. For available settings, see to [Table 12-1](#).

To change the baud rate

1. Disconnect the sensor from the computer or base unit, load and source. See "[To disconnect from the DUT](#)" on page 15.
2. Place the sensor on its front side with the power handling capacity diagram (1) facing upwards.

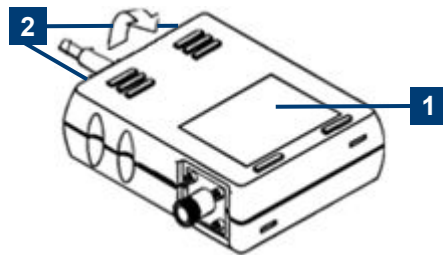

3. Remove both screws indicated by position (2).
4. Remove the upper part of the plastic housing:
 - a) Lift it at the rear where you have removed the screws.
 - b) Remove it.
5. Set the baud rate by changing the dip switch positions. See [Table 12-1](#).
The baud rate setting shown as an example is 19200 Bd.
6. Close the upper part of the plastic housing.
7. Screw the two screws back on.

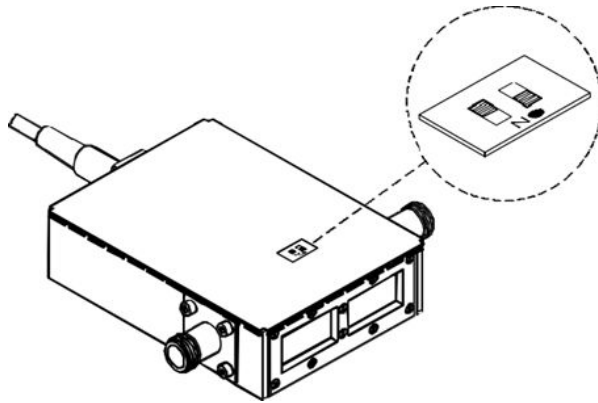

Table 12-1: Baud rate settings

Baud rate	DIP switch position	
	Left	Right
38400 Bd	Off	Off
19200 Bd	On	Off
9600 Bd	Off	On
4800 Bd	On	On

12.2 Regular checks

If the sensor is used frequently, check the RF connectors for visible damage - bent inner conductors, broken contact springs and so on. If the RF connectors are damaged, stop using the sensor. Contact Rohde & Schwarz customer support, see [Chapter 9.4, "Contacting customer support"](#), on page 79.

Checking the integrity of the RF connector

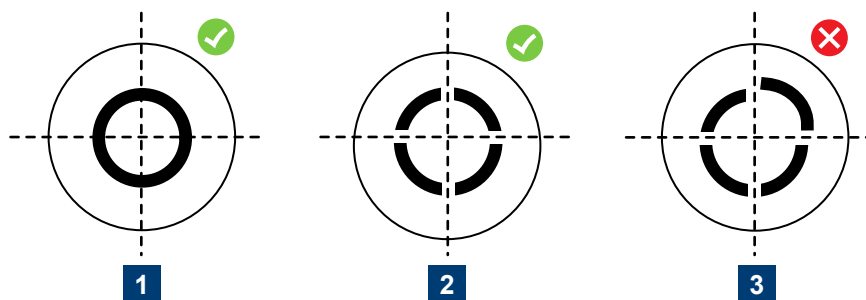

- 1 = Perfectly formed contacts
- 2 = Normal wear
- 3 = Damaged contacts

Checking the concentricity of the RF connector

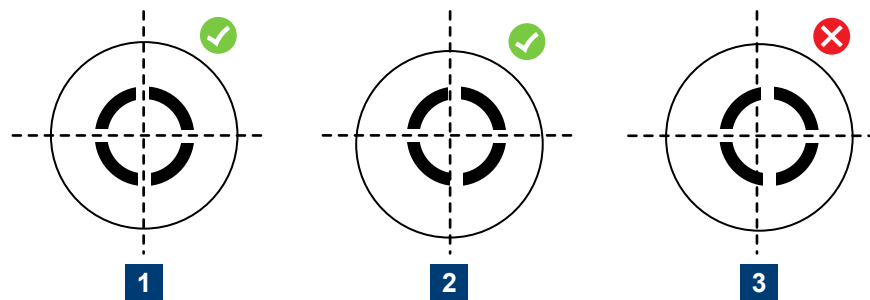

- 1 = Perfectly concentric
 2 = Slightly off-center
 3 = Excessively off-center

12.3 Cleaning

1. Disconnect the R&S NRT-Zxx:
 - a) From source and load.
 - b) From the computer or the base unit.
2. Clean the outside of the product using a lint-free cloth. You can dampen the cloth with water but keep in mind that the casing is not waterproof. If you use 70% isopropyl alcohol instead of water, be careful not to damage the labeling. Do not use cleaning agents that can damage the instrument such as solvents, acids or alkalis.
3. Clean the RF connectors as follows:
 - a) Dislodge any particles using solvent-free compressed air.
 - b) Clean the inside and the connector threads using a foam swab or lint-free cloth dampened with isopropyl alcohol or ethanol.

Further information:

- ["To disconnect from the DUT"](#) on page 15
- Application note [1MA99](#): "Guidance on Selecting and Handling Coaxial RF Connectors used with Rohde & Schwarz Test Equipment"

12.4 Storage

Put plastic end caps on the RF connectors to protect them from damage. Protect the sensor against dust.

Ensure that the environmental conditions, e.g. temperature range and climatic load, meet the values specified in the specifications document.

12.5 Disposal

Rohde & Schwarz is committed to making careful, ecologically sound use of natural resources and minimizing the environmental footprint of our products. Help us by disposing of waste in a way that causes minimum environmental impact.

Disposing of electrical and electronic equipment

A product that is labeled as follows cannot be disposed of in normal household waste after it has come to the end of its life. Even disposal via the municipal collection points for waste electrical and electronic equipment is not permitted.



Figure 12-1: Labeling in line with EU directive WEEE

Rohde & Schwarz has developed a disposal concept for the eco-friendly disposal or recycling of waste material. As a manufacturer, Rohde & Schwarz completely fulfills its obligation to take back and dispose of electrical and electronic waste. Contact your local service representative to dispose of the product.

List of commands

APPL.....	59
AVER.....	41
BOOT.....	60
BURS:PER.....	33
BURS:WIDT.....	33
CBAV.....	41
CCDF.....	33
CCDF.....	41
CF.....	42
DIR.....	33
DISP:FORW.....	34
DISP:REFL.....	35
DISP:STAT.....	35
DMA.....	60
FILT:AVER:COUN.....	38
FILT:AVER:MODE.....	39
FILT:INT:MODE.....	39
FILT:INT:TIME.....	39
FILT:RES.....	40
FILT:VID.....	40
FREQ.....	36
FTRG.....	51
HELP.....	60
ID.....	62
MBAV.....	43
MOD:RATE.....	44
MOD:TYPE.....	45
OFFS.....	46
PEP.....	43
PEP:HOLD.....	46
PEP:TIME.....	46
PORT.....	48
POW.....	49
PURGE.....	63
QSTN.....	52
RCO.....	49
RESET.....	49
RL.....	50
RTRG.....	52
SERV:TEST.....	63
SETUP:RCL.....	63
SETUP:SAVE.....	63
SPEC.....	54
STAT:ERR:CODE.....	58
STAT:ERR:TEXT.....	57
STAT:ERR:VALS.....	59
STAT:MEAS.....	56

SWR.....50
ZERO.....51

Index

A

Average power measurement	41
Averaging	36

B

Base unit	
Connecting	16
Baud rate	
Checking	89
Setting	89
Brochures	11

C

Calculated burst average measurement	41
Checking	13
Cleaning	91
Command processing	71
Background power	72
Data record	72
Hardware	72
Output unit	72
Temperature	72
Command syntax	
Query	64
Setting	64
Complementary cumulative distribution function measurement	41
Computer	
Connecting	15
Connecting	
Base unit	16
Computer	15
Legacy systems	17
Connector	
Host interface	18
RF	18
Crest factor measurement	42
Customer support	79

D

Data sheets	11
Device responses	
See responses	66
Device-dependent messages	64
Syntax	64
Disposal	92
Documentation overview	10
DUT	
Connecting	14
Disconnecting	14

E

EMC class	13
Error status	73

F

Firmware update	29
Problems	30
RSU file	29
Forward measurement	40
Average power	41
Calculated burst average	41
Complementary cumulative distribution function	41
Crest factor	42
Measured burst average	43
Peak envelope power	43

G

Getting started	10
-----------------------	----

H

Hardware	
Functions	70
Host interface	18

I

Installation	
Firmware	29
Instrument security procedures	10
Integration time	37
Intended use	7

K

Key facts	11
-----------------	----

L

Labels	8
Legacy systems	
Connecting	17
Load	14

M

Maintenance	89
Cleaning	91
Disposal	92
Regular checks	90
Storage	91
Measured burst average measurement	43
Measurement	
Basics	28
Forward measurement	40
Reverse measurement	49
Messages	
Device-dependent	64
Sensor	64

O

Open source acknowledgment (OSA)	11
----------------------------------------	----

Operating concepts	20
R&S NRT2	20
R&S Virtual NRT	20
Remote control	22
Operating conditions	13
P	
Parameter	65
Numerical	65
Text	66
Peak envelope power measurement	43
Performance test report	
R&S NRT-Z14	86
R&S NRT-Z44	87
Power handling capacity	18
Power measurement	49
Power-up test	77
Preparing for use	13
Q	
Queries	64
R	
R&S NRP-Toolkit	
Firmware update	30
Installation under Windows	31
System requirements	31
R&S NRT2	20
R&S Virtual NRT	20
Installing	21
Measurement	21
Required equipment	21
Setup	21
Reference plane	47
Reflection coefficient measurement	49
Regular checks	90
Regulatory information	7
Release notes	11
Remote commands	32
General commands	59
Measurement settings	32
Parameter	65
Queries	51
Selftest	63
Remote control	32
Basics	64
Booting	27
Connection test	26
Interface settings	23
R&S Virtual NRT	23
Terminal program	23
Responses	66
Checksum header	66
Multiple-line	69
Status information	66
Status messages	69
Return loss measurement	50
Reverse measurement	49
Power	49
Reflection coefficient	49
Return loss	50
Standing wave ratio	50
RF connector	18
RSU file	29

S

Safety information	7
Safety instructions	7, 10
Security procedures	10
Selftest	63, 77
Sensor messages	
See device-dependent messages	64
Serial number	9
Setting commands	64
Source	14
Specifications	
Testing	80
Standing wave ratio measurement	50
Status messages	69
Status reporting system	72
Device status	73
Error status	73
Sensor status	73
Storage	91

T

Target audience	7
Test setup	13
Testing	
Power-up	77
Selftest	77
Setup	77
Testing rated specifications	80
AVG measurement	81
CCDF threshold	82
Directivity	84
Equipment	80
Matching	85
PEP measurement	83
Sequences	81
Setup	81
Transporting	88
Troubleshooting	77

U

Unpacking	13
Update file	29
User manual	10

V

Video bandwidth	37
-----------------------	----

W

Warning message	9
Welcome	10