

R&S®NRPxTWG(N)

Thermal Waveguide Power Sensors

User Manual



1178837102
Version 20

ROHDE & SCHWARZ
Make ideas real



This document describes the following thermal waveguide power sensors with firmware version 03.40 and higher:

- R&S®NRP75TWG (1700.2529K02)
- R&S®NRP75TWGN (1440.5010K02)
- R&S®NRP90TWG (1700.2312K02)
- R&S®NRP90TWGN (1440.5078K02)
- R&S®NRP110TWG (1173.8709K02)
- R&S®NRP110TWGN (1440.5132K02)
- R&S®NRP140TWG (1440.5190K02)
- R&S®NRP140TWGN (1440.5378K02)
- R&S®NRP170TWG (1700.3754K02)
- R&S®NRP170TWGN (1440.5432K02)

This document describes the following accessories:

- R&S®NRP-ZKU (1419.0658K02/03/04/05)
- R&S®NRP-ZKC (1425.2442K02/03/04)
- R&S®NRP-ZK6 (1419.0664K02/03/04)
- R&S®NRP-ZK8 (1424.9408K02/03/04)
- R&S®R&S NRP-Z5 (1146.7740K02)

© 2025 Rohde & Schwarz

Muehldorfstr. 15, 81671 Muenchen, Germany

Phone: +49 89 41 29 - 0

Email: info@rohde-schwarz.com

Internet: www.rohde-schwarz.com

Subject to change – data without tolerance limits is not binding.

R&S® is a registered trademark of Rohde & Schwarz GmbH & Co. KG.

Mac and macOS are trademarks of Apple Inc., registered in the U.S. and other countries and regions.

All other trademarks are the properties of their respective owners.

1178.8371.02 | Version 20 | R&S®NRPxTWG(N)

Throughout this document, R&S® is indicated as R&S.

Contents

1	Safety and regulatory information.....	9
1.1	Safety instructions.....	9
1.2	Labels on the product.....	10
1.3	Warning messages in the documentation.....	11
1.4	CE declaration of conformity.....	11
1.5	Where to find key documents on Rohde & Schwarz.....	11
2	Welcome.....	12
2.1	Documentation overview.....	12
2.1.1	Getting started manual.....	12
2.1.2	User manuals.....	12
2.1.3	Printed safety instructions.....	12
2.1.4	Instrument security procedures.....	12
2.1.5	Specifications documents and product brochures.....	13
2.1.6	Application notes, application cards, white papers, etc.....	13
2.1.7	Calibration certificate.....	13
2.1.8	Release notes and open source acknowledgment (OSA).....	13
2.2	Key features.....	13
3	Preparing for use.....	15
3.1	Unpacking and checking.....	15
3.2	Choosing the operating site.....	15
3.3	Considerations for test setup.....	16
3.4	Connecting to a DUT.....	16
3.5	Powering the sensor.....	17
3.6	Connecting a cable to the host interface.....	18
3.7	Connecting to a controlling host.....	18
3.7.1	Computer.....	19
3.7.2	Android smartphone or tablet with USB type C.....	22
3.7.3	Base units and Rohde & Schwarz instruments.....	23
3.7.4	Using a LAN connection.....	24
4	Sensor tour.....	30

4.1	RF connector.....	30
4.2	Status information.....	31
4.3	Host interface.....	32
4.4	Trigger I/O connector.....	32
4.5	LAN PoE interface.....	32
5	Operating concepts.....	34
5.1	R&S NRP-Toolkit.....	34
5.1.1	Versions and downloads.....	34
5.1.2	System requirements.....	34
5.1.3	R&S NRP-Toolkit for Windows.....	35
5.2	Web user interface.....	37
5.3	Remote control.....	38
5.4	R&S NRX.....	38
5.5	R&S NRPV.....	39
5.6	R&S Power Viewer.....	39
5.7	R&S Power Viewer Mobile.....	40
6	Web user interface.....	41
6.1	Main dialog of the web user interface.....	41
6.2	Setting the unit.....	42
6.3	Common settings.....	43
6.4	Measurement modes.....	45
6.4.1	Continuous average mode.....	45
6.5	Settings.....	46
6.5.1	Sensor settings.....	46
6.5.2	Averaging settings.....	47
6.5.3	Trigger settings.....	48
6.5.4	System settings.....	50
7	Firmware update.....	54
7.1	Downloading the firmware update file.....	54
7.2	Updating the firmware.....	54
7.2.1	Using the Firmware Update program.....	54
7.2.2	Using the web user interface.....	56

7.2.3	Using SCP or SFTP.....	57
7.2.4	Using remote control.....	58
8	Remote control commands.....	60
8.1	Conventions used in SCPI command descriptions.....	60
8.2	Common commands.....	61
8.3	Preparing for the measurement.....	65
8.3.1	Selecting the reference source.....	65
8.3.2	Selecting a measurement mode.....	66
8.4	Controlling the measurement.....	66
8.4.1	Starting and ending a measurement.....	66
8.4.2	Triggering.....	68
8.4.3	Controlling the measurement results.....	70
8.4.4	Interplay of the controlling mechanisms.....	71
8.4.5	Configuring the trigger.....	74
8.5	Configuring the measurement modes.....	80
8.5.1	Continuous average measurement.....	80
8.6	Configuring basic measurement parameters.....	82
8.6.1	Configuring auto averaging.....	82
8.6.2	Setting the frequency.....	86
8.6.3	Configuring corrections.....	87
8.7	Configuring measurement results.....	103
8.7.1	Setting the power unit.....	103
8.7.2	Setting the result format.....	104
8.8	Querying measurement results.....	105
8.8.1	Continuous average measurement results.....	105
8.9	Calibrating, zeroing.....	107
8.10	Running a self-test.....	110
8.11	Configuring the system.....	110
8.11.1	Preset and initialize.....	111
8.11.2	Reboot and restart.....	111
8.11.3	Firmware update.....	111
8.11.4	Password management.....	112
8.11.5	Network settings.....	113

8.11.6	Remote settings.....	117
8.11.7	Sensor information.....	119
8.11.8	Status display and update.....	121
8.11.9	Measurement limits and levels.....	122
8.11.10	Errors.....	123
8.12	Using the status register.....	125
8.12.1	General status register commands.....	126
8.12.2	Reading the CONDition part.....	126
8.12.3	Reading the EVENT part.....	127
8.12.4	Controlling the ENABLE part.....	127
8.12.5	Controlling the negative transition part.....	127
8.12.6	Controlling the positive transition part.....	128
9	Performing measurement tasks - programming examples.....	129
9.1	Performing the simplest measurement.....	129
9.2	Performing a buffered continuous average measurement.....	129
10	Remote control basics.....	132
10.1	Remote control interfaces and protocols.....	132
10.1.1	USB interface.....	132
10.1.2	Ethernet interface.....	134
10.2	Status reporting system.....	136
10.2.1	Overview.....	136
10.2.2	Device status register.....	137
10.2.3	Questionable status register.....	139
10.2.4	Standard event status and enable register (ESR, ESE).....	142
10.2.5	Operation status register.....	143
11	Data management.....	151
12	Troubleshooting.....	152
12.1	Displaying status information.....	152
12.2	Error messages.....	152
12.3	Performing a self-test.....	153
12.3.1	Interpreting the test results.....	154
12.4	Problems during a firmware update.....	155

12.5	Cannot establish a LAN connection.....	156
12.6	Collecting information for technical support.....	156
12.7	Contacting customer support.....	156
13	Transporting.....	158
14	Maintenance, storage and disposal.....	159
14.1	Cleaning.....	159
14.2	Storage.....	159
14.3	Disposal.....	159
	List of commands.....	161
	Index.....	165

1 Safety and regulatory information

The product documentation helps you use the product safely and efficiently. Follow the instructions provided here and in the following sections.

Intended use

The sensors are intended for accurate and uncomplicated power measurements in production, R&D and calibration labs as well as for installation and maintenance tasks.

The main applications are most accurate power measurements for reference applications and use in calibration labs.

The supported base units are listed in the specifications document.

Observe the operating conditions and performance limits stated in the specifications document.

Target audience

The target audience is developers and technicians. The required skills and experience in power measurements depend on the used operating concept.

Where do I find safety information?

Safety information is part of the product documentation. It warns you of potential dangers and gives instructions on how to prevent personal injury or damage caused by dangerous situations. Safety information is provided as follows:

- In [Section 1.1, "Safety instructions"](#), on page 9. The same information is provided in many languages in printed format. The printed "Safety Instructions" for "Power Sensors" (document number 1171.1865.99) are delivered with the product.
- Throughout the documentation, safety instructions are provided when you need to take care during setup or operation.

1.1 Safety instructions

Products from the Rohde & Schwarz group of companies are manufactured according to the highest technical standards. To use the products safely, follow the instructions provided here and in the product documentation. Keep the product documentation nearby and offer it to other users.

Use the product only for its intended use and within its performance limits. Intended use and limits are described in the product documentation such as the specifications document, manuals and the printed "Safety Instructions" document. If you are unsure about the appropriate use, contact Rohde & Schwarz customer support.

Using the product requires skilled persons or specially trained personnel. These users also need sound knowledge of at least one of the languages in which the user interfaces and the product documentation are available.

Reconfigure or adjust the product only as described in the product documentation or the specifications document. Any other modifications can affect safety and are not permitted.

Never open the casing of the product. Only service personnel authorized by Rohde & Schwarz are allowed to repair the product. If any part of the product is damaged or broken, stop using the product. Contact Rohde & Schwarz customer support at <https://www.rohde-schwarz.com/support>.



Operating the product

Only use the product indoors. The product casing is not waterproof.

Observe the ambient conditions stated in the specifications document. Examples of ambient conditions are altitude, operating temperature and climatic loads.

Meaning of safety labels

Safety labels on the product and its accessories warn against potential hazards.

	<p>Potential hazard Read the product documentation to avoid personal injury or product damage.</p>
	<p>Hot surface Do not touch. Risk of skin burns. Risk of fire.</p>

1.2 Labels on the product

Labels on the product inform about:

- Personal safety
See "[Meaning of safety labels](#)" on page 10.
- Environment safety
See [Table 1-1](#).
- Identification of the product
A sticker on the product shows the product ID, a combination of the order number and the serial number of the product. The serial number identifies the product uniquely.
See also "[Default host name](#)" on page 28.

Table 1-1: Labels regarding environment safety

	<p>Labeling in line with EN 50419 for disposal of electrical and electronic equipment after the product has come to the end of its life. For more information, see "Disposing of electrical and electronic equipment" on page 160.</p>
---	--

1.3 Warning messages in the documentation

A warning message points out a risk or danger that you need to be aware of. The signal word indicates the severity of the safety hazard and how likely it will occur if you do not follow the safety precautions.

NOTICE

Potential risks of damage. Could result in damage to the supported product or to other property.

1.4 CE declaration of conformity

The CE declaration of conformity is delivered with the product. Keep the document for further reference.

The current version of this CE declaration of conformity is available at:

www.rohde-schwarz.com/product/nrp-t-tn

1.5 Where to find key documents on Rohde & Schwarz

Certificates issued to Rohde & Schwarz that are relevant for your country are provided at www.rohde-schwarz.com/key-documents, e.g. concerning:

- Quality management
- Environmental management
- Information security management
- Accreditations

2 Welcome

This section provides an overview of the user documentation and an introduction to the sensor.

In the manuals, the terms sensor and power sensor are used synonymously.

2.1 Documentation overview

This section provides an overview of the R&S NRPxTWG(N) user documentation. Unless specified otherwise, you find the documents at:

www.rohde-schwarz.com/manual/nrp-t-tn

Further documents are available at:

www.rohde-schwarz.com/product/nrp-t-tn

2.1.1 Getting started manual

Introduces the R&S NRPxTWG(N) and describes how to set up and start working with the product. Includes basic operations and general information, e.g. safety instructions, etc. A printed version is delivered with the power sensor.

2.1.2 User manuals

Contains the description of all instrument modes and functions. It also provides an introduction to remote control, a complete description of the remote control commands with programming examples, and information on maintenance and interfaces. Includes the contents of the getting started manual.

The user manual is also available for download or for immediate display on the internet.

2.1.3 Printed safety instructions

Provides safety information in many languages. The printed document is delivered with the product.

2.1.4 Instrument security procedures

Deals with security issues when working with the R&S NRPxTWG(N) in secure areas. It is available for download on the internet.

2.1.5 Specifications documents and product brochures

The specifications document, also known as the data sheet, contains the technical specifications of the R&S NRPxTWG(N). It also lists the firmware applications and their order numbers, and optional accessories.

The brochure provides an overview of the instrument and deals with the specific characteristics.

www.rohde-schwarz.com/brochure-datasheet/nrp-t-tn

2.1.6 Application notes, application cards, white papers, etc.

These documents deal with special applications or background information on particular topics.

www.rohde-schwarz.com/application/nrp-t-tn

2.1.7 Calibration certificate

The document is available on <https://gloris.rohde-schwarz.com/calcert>. You need the device ID of your instrument, which you can find on a label on the product.

2.1.8 Release notes and open source acknowledgment (OSA)

The release notes list new features, improvements and known issues of the current software version, and describe the software installation.

The software uses several valuable open source software packages. An open source acknowledgment document provides verbatim license texts of the used open source software.

The open source acknowledgment document is provided on the software CD-ROM, included in the delivery.

www.rohde-schwarz.com/firmware/nrp-t-tn

2.2 Key features

The most important features for accurate and uncomplicated power measurements are top measurement accuracy and speed as well as simple operation on a base unit or a computer. The NRP sensors provide these characteristics in a comprehensive portfolio of LAN and USB power sensors.

All NRP sensors are independent measuring instruments. Using a USB adapter, you can directly connect them to a computer and operate them via the R&S NRPV software.

Functions and performance features:

- Fully characterized power sensors
- Minimized measurement uncertainty
- Intelligent averaging function minimizes measurement time
- Versatile measurement functions

Additional features:

- USBTMC for easy system integration
- Built-in trigger I/O port
- Sensor status at a glance with status LED
- Detachable cables for flexible operation

Almost every NRP sensor is available as LAN model. These sensors with networking capabilities are marked with a trailing N in their names.

R&S NRPxTWGN

Special LAN model features:

- Remote monitoring via LAN over any distance
- Power supply via power over Ethernet (PoE)
- Built-in web user interface with full power measurement support

The thermal power sensors are especially used for complex measurement tasks where highest accuracy counts.



For a detailed specification, refer to the specifications document and the brochure.

3 Preparing for use

Here, you can find basic information about setting up the product for the first time.

• Unpacking and checking	15
• Choosing the operating site	15
• Considerations for test setup	16
• Connecting to a DUT	16
• Powering the sensor	17
• Connecting a cable to the host interface	18
• Connecting to a controlling host	18

3.1 Unpacking and checking

1. Unpack the product carefully.
2. Retain the original packing material. Use it when transporting or shipping the product later.
3. Using the delivery notes, check the equipment for completeness.
4. Check the equipment for damage.

If the delivery is incomplete or equipment is damaged, contact Rohde & Schwarz.

3.2 Choosing the operating site

Specific operating conditions ensure proper operation and avoid damage to the product and connected devices. For information on environmental conditions such as ambient temperature and humidity, see the specifications document.

Electromagnetic compatibility classes

The electromagnetic compatibility (EMC) class indicates where you can operate the product. The EMC class of the product is given in the specifications document.

- Class B equipment is suitable for use in:
 - Residential environments
 - Environments that are directly connected to a low-voltage supply network that supplies residential buildings
- Class A equipment is intended for use in industrial environments. It can cause radio disturbances in residential environments due to possible conducted and radiated disturbances. It is therefore not suitable for class B environments. If class A equipment causes radio disturbances, take appropriate measures to eliminate them.

3.3 Considerations for test setup

Pay particular attention to the following aspects when handling sensors.

Preventing electrostatic discharge (ESD)

Electrostatic discharge is most likely to occur when you connect or disconnect a device under test (DUT). It can damage the electronic components of the product and the DUT.

EMI impact on measurement results

Electromagnetic interference (EMI) can affect the measurement results.

To suppress electromagnetic radiation during operation:

- Use high-quality shielded cables, for example, double-shielded RF and interface cables.
- Always terminate open cable ends.
- Ensure that connected external devices comply with EMC regulations.

Signal input and output levels

Information on signal levels is provided in the specifications document. Keep the signal levels within the specified ranges to avoid damage to the product and connected devices.

3.4 Connecting to a DUT

For connecting the sensor to a DUT, use the RF connector. See also [Section 4.1, "RF connector"](#), on page 30.

To connect to the DUT

1. Ensure that the waveguide flange of your DUT is compatible with the waveguide flange of the sensor. See [Table 4-1](#).
2. Remove the protective covers from the waveguide flanges, if mounted.
3. Inspect both waveguide flanges carefully. Look for metal particles, contaminants and defects.
If either waveguide flange is damaged, do not proceed, because the risk of damaging the mating connector is too high.
4. If you want to use precision alignment dowels, insert them into the holes intended for them. See (3) in [Figure 3-1](#).
5. Align the pins, dowels and corresponding receiving holes of the sensor and DUT carefully. See also [Figure 3-1](#). Avoid scratching the contact surfaces of the waveguide flanges.

6. Insert the pins and dowels straight into the receiving holes. Take care not to tilt the sensor.

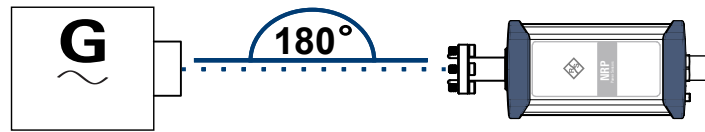

7. Tighten the screws of the waveguide flange manually.
8. Tighten the screws of the waveguide flange using a torque wrench with the nominal torque of 0.58 Nm (5" lbs) to ensure maximum measurement accuracy.

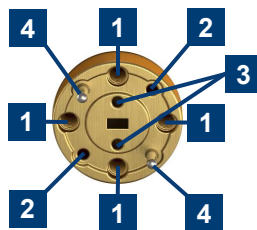

Figure 3-1: Waveguide flange

- 1 = four holes for screws
- 2 = two holes for DUT pins
- 3 = two holes for precision alignment dowels
- 4 = two alignment pins

To disconnect from the DUT

1. Loosen the screws of the waveguide flange.
2. Remove the sensor.

3.5 Powering the sensor

The electrical power for the sensor is supplied over one of the following interfaces:

- Host interface
See [Section 4.3, "Host interface"](#), on page 32.
- LAN PoE interface
Available only for LAN sensors. See [Section 4.5, "LAN PoE interface"](#), on page 32.



If you use the Ethernet interface of the LAN sensor, you have to provide the electrical power over Ethernet - by power over Ethernet (PoE). You *cannot* provide the electrical power over the host interface instead.

Choose the power sourcing equipment (PSE) with care

Only use PoE power sourcing equipment (PSE) as specified in the IEEE standards 802.3af or IEEE 802.3at.

Otherwise, the following can happen:

- If too much power is supplied, the LAN sensor can get overheated and become damaged as a result.
- If the supplied power is not sufficient, the LAN sensor does not work properly or not at all.

3.6 Connecting a cable to the host interface

For connecting the sensor to a host, use the host interface. The required cable depends on the host. The cable types and lengths are listed in the specifications document. See also [Section 4.3, "Host interface"](#), on page 32.

To connect a cable to the host interface of the sensor

1. Insert the screw-lock cable connector into the host interface connector. Take care that the guide lug on the left side of the host interface connector fits into the guide gap of the cable connector.
2. To minimize the chance of cross-threading, turn the end cap counterclockwise until the threads of the end cap align with the threads of the connector.
3. Tighten the union nut carefully without using any force.

To disconnect the host interface of the sensor

1. Loosen the union nut of the screw-lock cable connector.
2. Remove the cable.

3.7 Connecting to a controlling host

As a controlling host, you can use:

- [Computer](#)
- [Base units and Rohde & Schwarz instruments](#)
- [Android smartphone or tablet with USB type C](#)

For operating the sensor, you can choose from various possibilities. For details, see [Section 5, "Operating concepts"](#), on page 34.

3.7.1 Computer

If the controlling host is a computer, you can establish the connection using:

- Host interface
See [Section 3.7.1.1, "Using a simple USB connection"](#), on page 19.
See [Section 3.7.1.2, "Using R&S NRP-Z5 sensor hub setup"](#), on page 20.
- LAN interface, if the sensor is a LAN sensor.
See [Section 3.7.4, "Using a LAN connection"](#), on page 24.

3.7.1.1 Using a simple USB connection

All sensors can be connected to the USB interface of a computer.

Required equipment

- Sensor
- R&S NRP-ZKU or R&S NRP-ZKC cable
- Computer with USB type A or USB type C interface, respectively

Setup

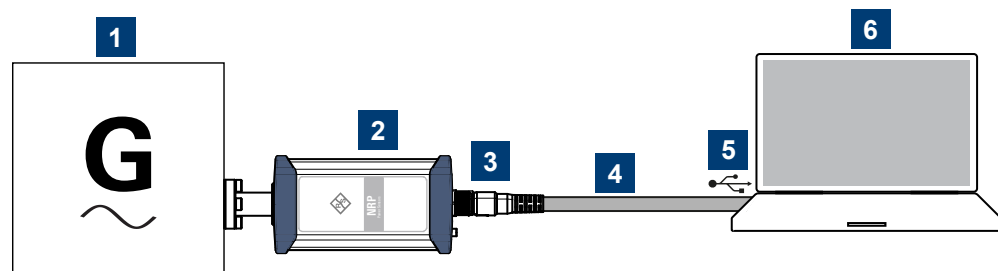

Figure 3-2: Setup with an R&S NRP-ZKU cable

- 1 = Signal source
- 2 = Sensor
- 3 = Host interface
- 4 = R&S NRP-ZKU or R&S NRP-ZKC cable
- 5 = USB connector
- 6 = Computer with installed VISA driver or R&S NRP-Toolkit

1. Connect the R&S NRP-ZKU cable to the sensor.
See ["To connect a cable to the host interface of the sensor"](#) on page 18.
2. Connect the USB connector to the computer.
3. **NOTICE!** Incorrectly connecting or disconnecting the sensor can damage the sensor or lead to incorrect results. Follow the instructions in ["To connect to the DUT"](#) on page 16.
Connect the sensor to the signal source (DUT).
4. On the computer, start a software application to view the measurement results.

See [Section 5, "Operating concepts"](#), on page 34.



If the computer has a USB type C port, use an R&S NRP-ZKC cable instead of an R&S NRP-ZKU cable.

3.7.1.2 Using R&S NRP-Z5 sensor hub setup

The R&S NRP-Z5 sensor hub (high-speed USB 2.0) can host up to four sensors and provides simultaneous external triggering to all connected sensors.

Required equipment

- 1 to 4 sensors
- 1 R&S NRP-ZK6 cable per sensor
- R&S NRP-Z5 sensor hub
- External power supply, delivered with the R&S NRP-Z5 sensor hub. The supplied external power supply is short-circuit proof and is also protected by an internal fuse. It is not possible to change the fuse or open the unit.

You can use an alternative DC voltage source, but it must fulfill the following requirements:

- Supplies an output voltage of 12 V to 24 V and a power output of at least 24 W. Do not use an extra-low voltage supply system.
- Is in the same building as the R&S NRP-Z5.
- Is connected to the R&S NRP-Z5 by a cable that is no longer than 30 m.
- USB cable, delivered with the R&S NRP-Z5 sensor hub. Alternatively, you can use any other USB-2.0-certified USB connector type A to USB connector type B cable with a maximum length of 5 m. If a locking connection is required at the instrument end, you can use the passive R&S NRP-Z4 interface adapter instead of a standard USB cable.
- Computer
- Optional: BNC cables to connect the trigger input and trigger output signals.

Setup

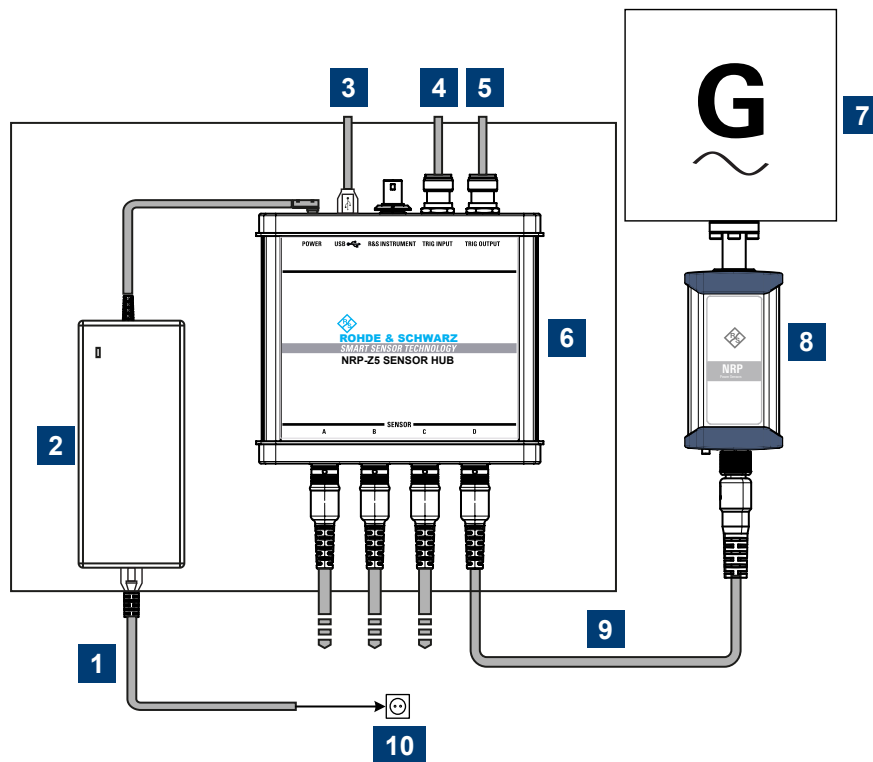

Figure 3-3: Setup with an R&S NRP-Z5 sensor hub

- 1 = Connect to AC power supply.
- 2 = External power supply unit
- 3 = Connect to a computer.
- 4 = Optional: Connect to the trigger source.
- 5 = Optional: Connect to the triggered device.
- 6 = R&S NRP-Z5 sensor hub
- 7 = Signal source (DUT)
- 8 = Sensor
- 9 = R&S NRP-ZK6 cable
- 10 = AC power supply

1. Connect each sensor to the R&S NRP-Z5 using a R&S NRP-ZK6 cable. See ["To connect a cable to the host interface of the sensor"](#) on page 18.
2. Connect the R&S NRP-Z5 to the computer using a USB cable.
3. Connect the external power supply unit to the R&S NRP-Z5 and to an AC supply connector.
4. If you want to use an external trigger source, connect the trigger input of the R&S NRP-Z5 sensor hub to the trigger source using a BNC cable.
5. If you want to use the trigger signal externally, connect the trigger output of the R&S NRP-Z5 sensor hub to the trigger device using a BNC cable.

6. **NOTICE!** Incorrectly connecting or disconnecting the sensor can damage the sensor or lead to incorrect results. Follow the instructions in ["To connect to the DUT"](#) on page 16.
Connect each sensor to the signal source (DUT).
7. On the computer, start a software application to view the measurement results. See [Section 5, "Operating concepts"](#), on page 34.

3.7.2 Android smartphone or tablet with USB type C

You can operate the sensor using R&S Power Viewer Mobile. For details, see [Section 5, "Operating concepts"](#), on page 34.

Required equipment

- Sensor
- R&S NRP-ZKC cable
- Android smartphone or tablet with USB type C

Setup

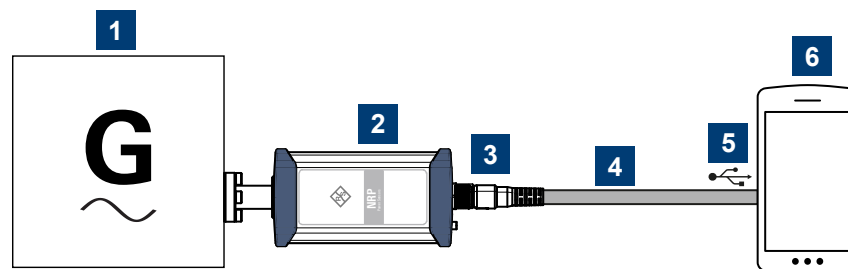

Figure 3-4: Setup with an R&S NRP-ZKC cable

- 1 = Signal source
- 2 = Sensor
- 3 = Host interface
- 4 = R&S NRP-ZKC cable
- 5 = USB type C connector
- 6 = Android smartphone with installed R&S Power Viewer Mobile

1. Connect the R&S NRP-ZKC cable to the sensor host interface.
See ["To connect a cable to the host interface of the sensor"](#) on page 18.
2. Connect the R&S NRP-ZKC cable to the Android smartphone or tablet with a USB type C connector.
3. **NOTICE!** Incorrectly connecting or disconnecting the sensor can damage the sensor or lead to incorrect results. Follow the instructions in ["To connect to the DUT"](#) on page 16.
Connect the sensor to the signal source.

4. On the Android smartphone or tablet, start a software application to view the measurement results.
See [Section 5, "Operating concepts"](#), on page 34.

3.7.3 Base units and Rohde & Schwarz instruments

You can use the following instruments as a controlling host:

- R&S NRX base units
See [Section 3.7.3.1, "R&S NRX base unit"](#), on page 23.
- Supported Rohde & Schwarz instruments with a sensor connector
See the user manual of the instrument.

3.7.3.1 R&S NRX base unit

You can use an R&S NRX base unit as a controlling host.

The R&S NRX supports parallel measurements, if enhanced accordingly. For details, see the R&S NRX user manual.

Further information:

- [Section 5.4, "R&S NRX"](#), on page 38
- R&S NRX user manual

Required equipment

- Sensor
- R&S NRP-ZK8 cable to connect the sensor to the R&S NRX.
- R&S NRX

Setup

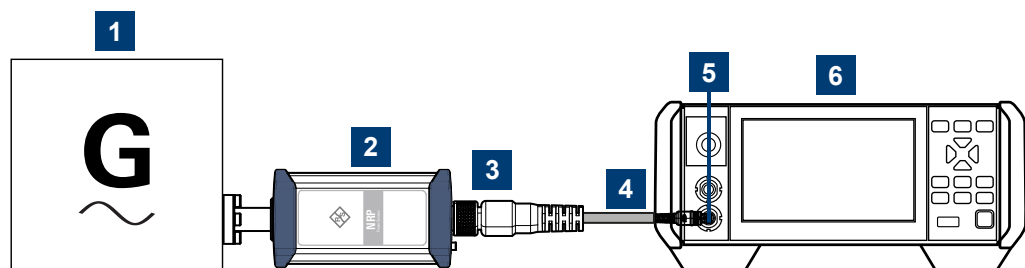

Figure 3-5: Setup with an R&S NRX base unit

- 1 = Signal source
- 2 = Sensor
- 3 = Host interface
- 4 = R&S NRP-ZK8 cable
- 5 = Sensor input connector of the R&S NRX
- 6 = R&S NRX base unit

1. Connect the sensor to the R&S NRX using the R&S NRP-ZK8 cable.
See ["To connect a cable to the host interface of the sensor"](#) on page 18.
2. **NOTICE!** Incorrectly connecting or disconnecting the sensor can damage the sensor or lead to incorrect results. Follow the instructions in ["To connect to the DUT"](#) on page 16.
Connect the sensor to the signal source (DUT).



If the sensor is a LAN sensor, you can set up a LAN connection instead of using the sensor input connector of the R&S NRX. See [Section 3.7.4, "Using a LAN connection"](#), on page 24.

3.7.4 Using a LAN connection

Requires a sensor with networking capabilities, a LAN sensor.



Do not establish a LAN connection if the sensor is operated over an R&S NRP-ZKU, R&S NRP-ZKC, R&S NRP-ZK6, or R&S NRP-ZK8.

The Ethernet interface of a LAN sensor requires PoE (power over Ethernet). See [Section 3.5, "Powering the sensor"](#), on page 17.

Electromagnetic interference (EMI) can affect the measurement results. To avoid any impact, use category 5 cables or better. For Ethernet cables available from Rohde & Schwarz, see the specifications document.

Depending on the available equipment, you can choose from different ways to connect a LAN sensor to a computer.

3.7.4.1 Setup with a PoE Ethernet switch

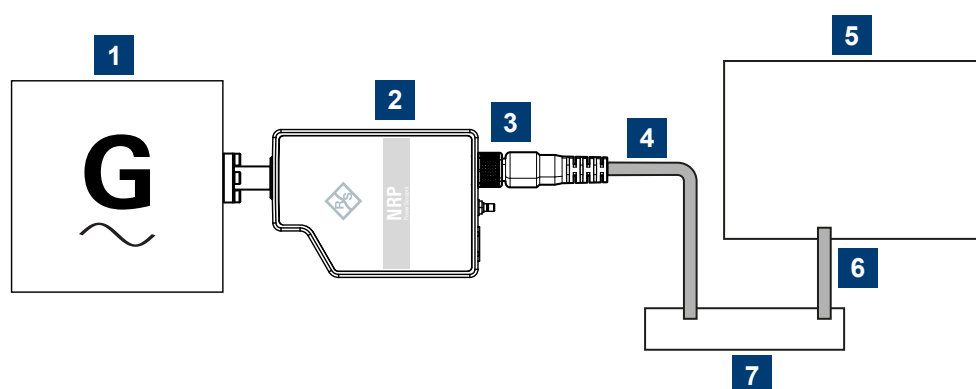

Figure 3-6: Setup with a PoE Ethernet switch

- 1 = Signal source
- 2 = Sensor
- 3 = RJ-45 Ethernet connector

- 4, 6 = RJ-45 Ethernet cable
- 5 = Computer
- 7 = Ethernet switch supporting PoE power delivery

1. **NOTICE!** Incorrectly connecting or disconnecting the sensor can damage the sensor or lead to incorrect results. Follow the instructions in ["To connect to the DUT"](#) on page 16.

Connect the sensor to the signal source.

2. **NOTICE!** Risk of damaging the sensor. Only use PoE power sourcing equipment (PSE) as described in ["Choose the power sourcing equipment \(PSE\) with care"](#) on page 18.

Connect the RJ-45 Ethernet connector of the sensor to an Ethernet switch that supports PoE power delivery.

3. Connect the computer to the Ethernet switch.
4. Establish a connection between the sensor and the network.
See [Section 3.7.4.2, "Establishing a connection to the network"](#), on page 27.

Setup with a PoE injector and a non-PoE Ethernet switch

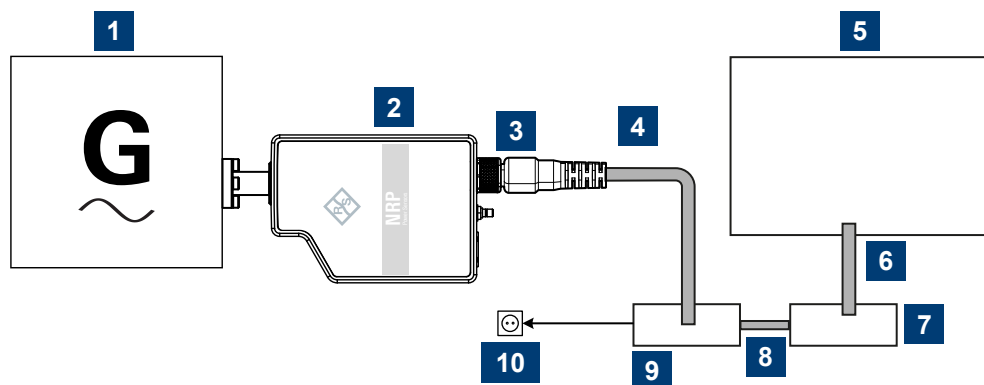

Figure 3-7: Setup with a PoE injector and a non-PoE Ethernet switch

- 1 = Signal source
- 2 = Sensor
- 3 = RJ-45 Ethernet connector
- 4,6,8 = RJ-45 Ethernet cable
- 5 = Computer
- 7 = Non-PoE Ethernet switch
- 9 = PoE injector
- 10 = AC supply

1. **NOTICE!** Incorrectly connecting or disconnecting the sensor can damage the sensor or lead to incorrect results. Follow the instructions in ["To connect to the DUT"](#) on page 16.

Connect the sensor to the signal source.

2. **NOTICE!** Risk of damaging the sensor. Only use PoE power sourcing equipment (PSE) as described in "[Choose the power sourcing equipment \(PSE\) with care](#)" on page 18.
Connect the RJ-45 Ethernet connector of the sensor to the output of the PoE injector.
3. Connect the PoE injector to a power supply.
4. Connect the input of the PoE injector to the non-PoE Ethernet switch.
5. Connect the computer to the non-PoE Ethernet switch.
6. Establish a connection between the sensor and the network.
See [Section 3.7.4.2, "Establishing a connection to the network"](#), on page 27.

Setup with a PoE injector

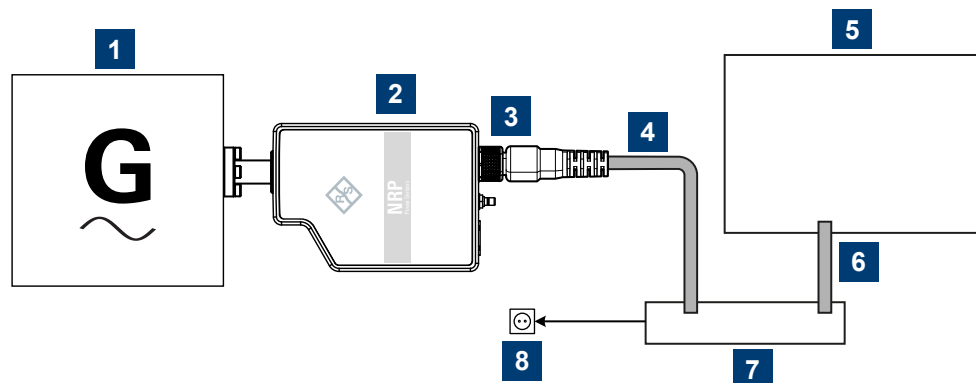

Figure 3-8: Setup with a PoE injector

- 1 = Signal source
- 2 = Sensor
- 3 = RJ-45 Ethernet connector
- 4, 6 = RJ-45 Ethernet cable
- 5 = Computer
- 7 = PoE injector
- 8 = AC supply

1. **NOTICE!** Incorrectly connecting or disconnecting the sensor can damage the sensor or lead to incorrect results. Follow the instructions in "[To connect to the DUT](#)" on page 16.
Connect the sensor to the signal source.
2. **NOTICE!** Risk of damaging the sensor. Only use PoE power sourcing equipment (PSE) as described in "[Choose the power sourcing equipment \(PSE\) with care](#)" on page 18.
Connect the RJ-45 Ethernet connector of the sensor to the output of the PoE injector.
3. Connect the PoE injector to a power supply.
4. Connect the computer to the input of the PoE injector.

5. Establish a network connection between the sensor and the computer.

3.7.4.2 Establishing a connection to the network

There are two methods to establish a network connection:

- Sensor and computer are connected to a common network. (Infrastructure network).
- Sensor and computer are connected only over the switch. (Peer-to-peer network).

In both cases, you can address the sensor as follows:

- [Section 3.7.4.3, "Using host names"](#), on page 28
- [Section 3.7.4.4, "Assigning the IP address"](#), on page 29

To set up a network Ethernet connection

1. Connect the sensor as described in [Section 3.7.4.1, "Setup with a PoE Ethernet switch"](#), on page 24.

By default, the sensor is configured to use dynamic TCP/IP configuration (DHCP) and to obtain the address information automatically.

If both LAN status LEDs are illuminated in green color, the sensor is correctly connected to the network.

Note: Establishing a connection can take up to 2 minutes per device.

2. If the LAN status LEDs show another state, no connection is possible. For possible solutions, see:
 - ["Network status LED"](#) on page 33
 - ["Troubleshooting for peer-to-peer connections"](#) on page 27

Troubleshooting for peer-to-peer connections

1. Allow a waiting time, especially if the computer has been used in a network before.
2. Check that only the main network adapter is active on the computer. If the computer has more than one network interfaces, explicitly disable all other network interfaces if you plan to utilize a peer-to-peer connection to the sensor.
3. Check that the IP address assigned to the remaining main network adapter starts with 169.254. The IANA (Internet-assigned numbers authority) has reserved the range 169.254.0.0 to 169.254.255.255 for the allocation of automatic private IP addresses (APIPA). Addresses from this range assuredly cause no conflicts with any routable IP address.
4. Try to establish a connection to the sensor with both the default host name and the host name extended with `.local`, for example:

```
nrp75twgn-123456
nrp75twgn-123456.local
```

3.7.4.3 Using host names

In a LAN that uses a domain name system (DNS) server, each connected computer or instrument can be accessed via a unique host name instead of an IP address. The DNS server translates the host name to the IP address. Using the host name is especially useful when a DHCP server is used, as a new IP address can be assigned each time the instrument is restarted.

Each sensor is delivered with a default host name assigned. You can change the default host name.

Default host name

The default host name follows the syntax:

`<device name>-<serial number>`, where:

- `<device name>` is the short name of your sensor.
For example, the `<device name>` of the R&S NRP75TWGN is `nrp75twgn`.
- `<serial number>` is the individual serial number of the sensor and is part of the product ID. The product ID is printed above the QR code on the product ID sticker. The product ID sticker is on the rear side of the sensor.

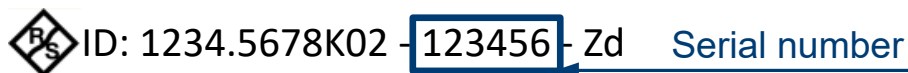

Figure 3-9: Product ID (example)

Example:

Serial number of the sensor: 123456

Default host name: `nrp75twgn-123456`

Host name in zero configuration networks, including peer-to-peer networks

The sensor supports zero configuration networking, used in networks without DHCP server, such as peer-to-peer networks. Thus, you can connect the sensor to a network without setting up services such as dynamic host configuration protocol (DHCP) and domain name system (DNS), or configuring the network settings manually.

For establishing a connection to the sensor, try the default host name and the host name extended with `.local` as shown in the example below. All communication for resolving names in the top-level-domain (TLD) `.local` are defined to be executed using dedicated local services and ports if no other DNS (domain name server) is available.

Example:

Default host name: `nrp75twgn-123456`

Extended host name: `nrp75twgn-123456.local`

3.7.4.4 Assigning the IP address

Depending on the network capabilities, the TCP/IP address information for the sensor can be obtained in different ways:

- If the network supports dynamic TCP/IP configuration using the dynamic host configuration protocol (DHCP), the address information can be assigned automatically.
- If the network does not support DHCP, the sensor tries to obtain the IP address via the zeroconf (APIPA = automatic private IP addressing) protocol. If this attempt does not succeed or if the sensor is set to use an alternate TCP/IP configuration, the IP address must be set manually.

For a description on how to set the IP address manually, see "[IP Address](#)" on page 50.



Use host names to identify the sensor

In networks using a DHCP server, it is recommended that you address the sensor by its unique host name, see [Section 3.7.4.3, "Using host names"](#), on page 28.

A *host name* is a unique identifier of the sensor that remains permanent as long as it is not explicitly changed. Hence, you can address a sensor by the same identification, irrespectively if a network or a point-to-point connection is used.

4 Sensor tour

This section provides an overview of the available connectors and LEDs of the sensor.

In the following figure, the USB sensor is shown on the left, the LAN sensor is shown on the right.

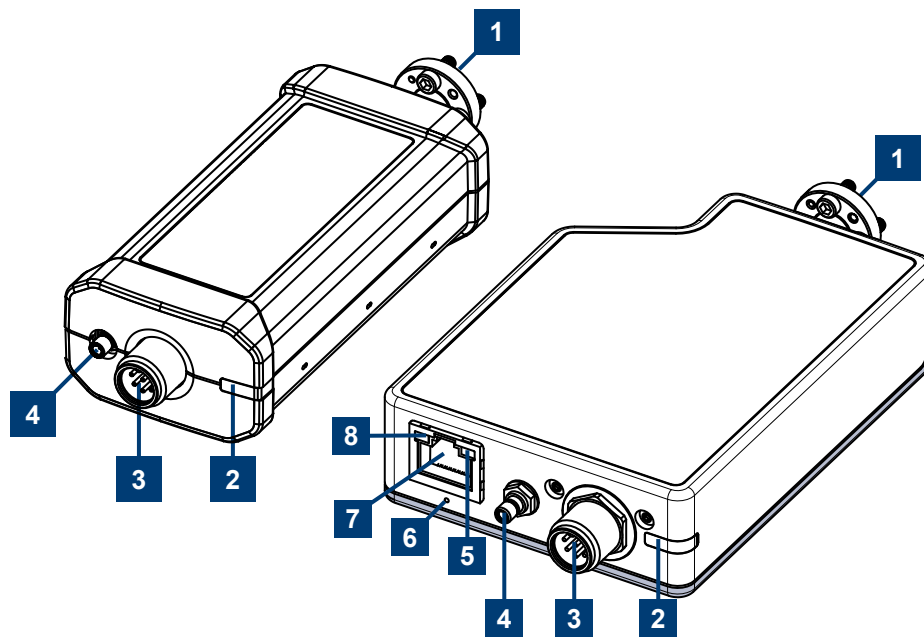

Figure 4-1: NRP sensor (example)

- 1 = RF connector, see [Section 4.1, "RF connector"](#), on page 30
- 2 = Status LED, see [Section 4.2, "Status information"](#), on page 31
- 3 = Host interface connector, see [Section 4.3, "Host interface"](#), on page 32
- 4 = Trigger I/O connector, see [Section 4.4, "Trigger I/O connector"](#), on page 32
- 5 = Network status LED, see ["Network status LED"](#) on page 33
- 6 = LAN reset button, see ["LAN reset button"](#) on page 32
- 7 = LAN connector, see [Section 4.5, "LAN PoE interface"](#), on page 32
- 8 = Power over Ethernet status LED, see ["PoE status LED"](#) on page 32

4.1 RF connector

Used to connect the sensor to a device under test (DUT) or a signal generator.

See [Section 3.4, "Connecting to a DUT"](#), on page 16.

For maximum measurement accuracy, tighten the RF connector using a torque wrench with a nominal torque as specified in the RF connector characteristics table.

Table 4-1: R&S NRPxTWG(N) RF connector characteristics

Model	Waveguide size	Frequency range	Tightening torque*
R&S NRP75TWG	WR-15	50 GHz to 75 GHz	0.58 Nm (5" lbs)
R&S NRP75TWGN			
R&S NRP90TWG	WR-12	60 GHz to 90 GHz	
R&S NRP90TWGN			
R&S NRP110TWG	WR-10	75 GHz to 110 GHz	
R&S NRP110TWGN			
R&S NRP140TWG	WR-8	90 GHz to 140 GHz	
R&S NRP140TWGN			
R&S NRP170TWG	WR-6.5	110 GHz to 170 GHz	
R&S NRP170TWGN			

* Use the torque wrench for waveguide flanges, R&S ZCTW, part number 1175.2014.02.

4.2 Status information

The status LED shows the state of the sensor by color and flashing frequency.

Table 4-2: Possible states

	Color	Illumination	State
○	White	Steady	Idle The sensor performs no measurement and is ready for operation.
☀	White	Fast flashing	Firmware update or reboot is in progress. When the firmware update or reboot is finished, the LED changes to glowing white steadily, indicating the idle state.
⦿	White	Slow flashing	Sanitizing in progress.
●	Yellow	Steady	Waiting for the trigger state.
●	Green	Steady	Measurement is running.
●	Turquoise blue	Steady	Zeroing is in progress.
⊗	Red	Slow flashing	Static error
⊗	Red	Fast flashing	Critical static error Note: If this state occurs after a firmware update, the update was not successful. Perform the firmware update again.

Further information:

- [Section 12.1, "Displaying status information"](#), on page 152
- [Section 12.2, "Error messages"](#), on page 152

4.3 Host interface

Used to connect the sensor and a USB host. For this purpose, an external cable is needed.

See [Section 3.6, "Connecting a cable to the host interface"](#), on page 18.

4.4 Trigger I/O connector

The SMB connector is used as an input for signals if the trigger source parameter is set to `EXTERNAL2`. It is used as an output for trigger signals if the sensor is operated in the trigger sender mode.

Further information:

- [Section 8.4.2, "Triggering"](#), on page 68

4.5 LAN PoE interface

Available only for LAN sensors.

The Ethernet RJ-45 connector is used to connect the LAN connector to a local area network (LAN).



If you use the Ethernet interface of the LAN sensor, you have to provide the electrical power over Ethernet - by power over Ethernet (PoE). You *cannot* provide the electrical power over the host interface instead.

See also [Section 3.5, "Powering the sensor"](#), on page 17.

LAN reset button

Resets the Ethernet connection parameters of the sensor to their default values.



PoE status LED

Shows whether the sensor is correctly powered over PoE or not.

Indication		State
	Green	The sensor is powered over PoE. You can operate it using the Ethernet interface.
Off	Not illuminated	No PoE power is present.

Network status LED

Shows whether the LAN connection to the network is established properly or not.

Indication		State
	Green	The sensor is correctly connected to the network. It has been assigned a valid IP address, either manually or via DHCP.
	Red	The sensor is not connected to the network correctly. Either the connection is erroneous or the sensor has not been assigned a valid IP address yet.

5 Operating concepts

• R&S NRP-Toolkit.....	34
• Web user interface.....	37
• Remote control.....	38
• R&S NRX.....	38
• R&S NRPV.....	39
• R&S Power Viewer.....	39
• R&S Power Viewer Mobile.....	40

5.1 R&S NRP-Toolkit



Before you start using an R&S sensor or sensor module, we recommend installing the latest R&S NRP-Toolkit.

The R&S NRP-Toolkit is the basic software package that supplies low-level drivers and tools for all R&S sensors, sensor modules and power standards.

5.1.1 Versions and downloads

The R&S NRP-Toolkit is available for:

- Microsoft Windows® operating system, as listed in [Section 5.1.2, "System requirements"](#), on page 34
- macOS

The latest versions for Windows and macOS are available at:

www.rohde-schwarz.com/software/nrp-t-tn

To obtain an R&S NRP-Toolkit for other operating systems, contact the Rohde & Schwarz customer support, see [Section 12.7, "Contacting customer support"](#), on page 156.

5.1.2 System requirements

Hardware requirements:

- Desktop computer or laptop, or an Intel-based Apple Mac
- LAN interface and equipment for setting up a LAN connection.
See [Section 3.7.4, "Using a LAN connection"](#), on page 24.

For supported Microsoft Windows versions, see the release notes.

5.1.3 R&S NRP-Toolkit for Windows

The R&S NRP-Toolkit installer for Windows-based systems contains the components described in the release notes.

To install the R&S NRP-Toolkit

1. Start the R&S NRP-Toolkit installer on the Windows-based computer.
In the "NRP-Toolkit Setup" dialog, the correct R&S NRP-Toolkit version for your operating system, 32-bit or 64-bit, is already selected.
2. Enable the packages that you want to install.
 - "NRP-Toolkit (SDK)"
See [Section 5.1.3.1, "Software development kit \(SDK\)"](#), on page 36.
 - "IVI Shared Components"
Installs the USBTMC driver. Enabled by default because the installation is recommended.
See also ["Computer requirements"](#) on page 132

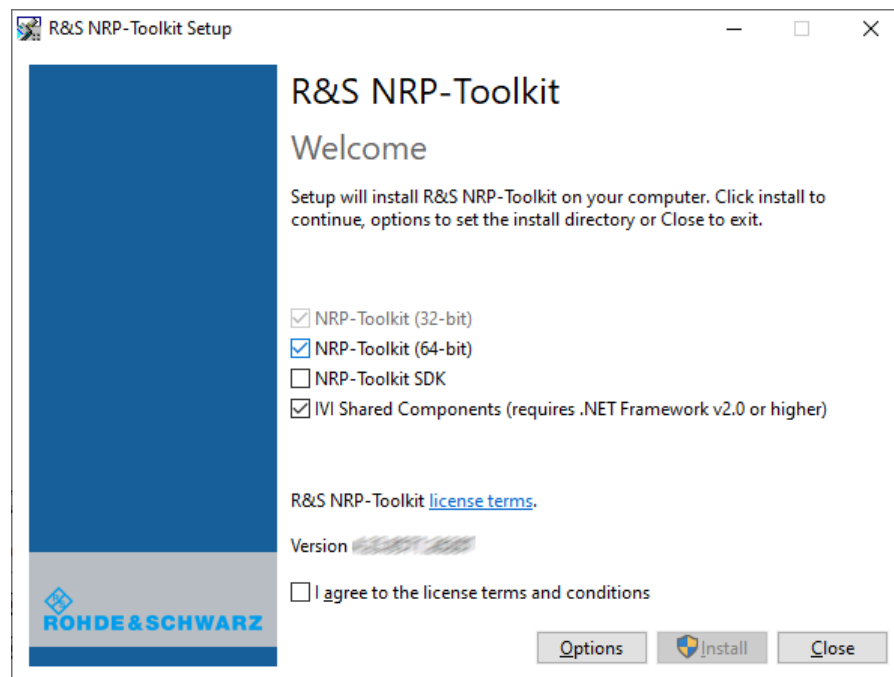

3. Accept the license terms to continue with the installation.
4. Click "Next" and complete the installation process.

To uninstall the R&S NRP-Toolkit

Use the Windows functionality for removing apps and features. The R&S NRP-Toolkit itself has no uninstall functionality.

5.1.3.1 Software development kit (SDK)

The software development kit (SDK) is a package of the R&S NRP-Toolkit. It provides programming examples for the R&S sensors.

See [Section 9, "Performing measurement tasks - programming examples"](#), on page 129.

5.1.3.2 Components of the R&S NRP-Toolkit for Windows

Access: "Start" > "NRP-Toolkit"

The components of the R&S NRP-Toolkit depend on the operating system. The following tools are part of the R&S NRP-Toolkit for Windows.

Configure Network Sensor

Useful if you have trouble establishing a LAN connection with a LAN sensor.

The tool provides the following functions:

- Configuring the network settings by temporarily using a USB connection.
- Discovering the sensors that have been configured via the zeroconf (APIA) protocol.

The tool comes with a guide (PDF) that is also available in the "Start" menu. The guide explains the network setup.

Firmware Update

Installs new firmware on the sensor.

See [Section 7, "Firmware update"](#), on page 54.

NRP Uncertainty Calculator

Determines the expanded measurement uncertainty. The tool comes with a manual (PDF) that is also available in the "Start" menu.

NRP Version Display

Displays version information of all installed, power measurement-relevant software packages.

S2P Wizard

Helps to import S-parameters into an NRP sensor.

S-Parameter Update Multi

Helps to load an S-parameter table into the sensor.

See [Section 8.6.3.6, "Using the S-Parameters program"](#), on page 93.

Terminal

Low-level communication program for sending commands to the sensor.

5.2 Web user interface

Requires a sensor with networking capabilities, a LAN sensor.

On the sensor, there is no installation required. With the integrated web user interface, you can easily configure the most common settings of the sensor and measure in the provided measurement modes.

You can use the web user interface with all devices and operating systems, including tablets and smartphones that are connected to the same network as the sensor.

The following browsers are supported:

- Mozilla Firefox
- Google Chrome
- Microsoft Edge
- Safari

Setup

Possible setups are described in [Section 3.7.4, "Using a LAN connection"](#), on page 24.

To display the web user interface

1. Open a supported browser.
2. Enter the host name or the IP address of the sensor that you want to connect to.

Example: `http://nrp75twgn-123456`

For details on how to find out the IP address or host name, refer to [Section 3.7.4.4, "Assigning the IP address"](#), on page 29 and [Section 3.7.4.3, "Using host names"](#), on page 28.

The main dialog of the web user interface opens.

For a detailed description of the web user interface, refer to [Section 6, "Web user interface"](#), on page 41.

To reload the webpage

After a firmware update or a reboot, you need to reload the webpage.

- ▶ Press [F5].

5.3 Remote control

You can remote control the R&S NRPxTWG(N) easily. The change to remote control occurs "on the fly" and has no influence on the manual operation.

Further information:

- [Section 8, "Remote control commands"](#), on page 60
- [Section 10, "Remote control basics"](#), on page 132
- [Section 3.7.1, "Computer"](#), on page 19

5.4 R&S NRX

The required equipment and the setup are described in [Section 3.7.3.1, "R&S NRX base unit"](#), on page 23.

In a measurement, the R&S NRX uses all sensor-dependent measurement functions and displays the results. Thus, you can configure both the measurement and the sensor.

Starting a measurement

1. Preset the R&S NRX and the connected R&S sensor.
 - a) Press the [Preset] key.
 - b) Select "Preset".All parameters are set to their defaults.
2. Execute zeroing:
 - a) Turn off all test signals before zeroing. An active test signal during zeroing causes an error.
 - b) Press the [Zero] key of the R&S NRX.
 - c) Select "Zero All Sensors".
3. Configure the measurement.
 - a) In the "Measurement Settings" dialog, select the "Measurement Type", for example "Continuous Average".
 - b) Select "Quick Setup" > "Auto Set".
4. Switch on the signal source.

The measurement starts, and the result is displayed in dBm.
5. If necessary, perform further settings. For further information, see the R&S NRX user manual.

5.5 R&S NRPV

The R&S NRPV enables you to measure power in all available measurement modes. Also, you can use up to four sensors simultaneously.

The R&S NRPV software is a separate standalone installation package. The installation package is provided on the Rohde & Schwarz website at:

www.rohde-schwarz.com/software/nrp-t-tn

Setup

1. Install the following on the computer:
 - Latest version of R&S NRP-Toolkit. See [Section 5.1, "R&S NRP-Toolkit"](#), on page 34.
 - Latest version of R&S NRPV. For information on installation, see the operating manual of the R&S NRPV.
2. Proceed as described in:
 - [Section 3.7.1.1, "Using a simple USB connection"](#), on page 19
 - [Section 3.7.1.2, "Using R&S NRP-Z5 sensor hub setup"](#), on page 20

Starting a measurement

For a detailed description of how to measure in this setup, refer to the operating manual of the R&S NRPV.

1. Start the R&S NRPV.
2. Turn off all test signals before zeroing. An active test signal during zeroing causes an error.
3. Execute zeroing.
4. Switch on the test signal of the signal source.
5. Start a measurement.

5.6 R&S Power Viewer

The R&S Power Viewer is software that simplifies many measurement tasks.

The R&S Power Viewer is a separate standalone installation package. The installation package is provided on the Rohde & Schwarz website at:

www.rohde-schwarz.com/software/nrp-t-tn

Setup

1. Install the following on the computer:

- Latest version of R&S NRP-Toolkit. See [Section 5.1, "R&S NRP-Toolkit"](#), on page 34.
 - Latest version of R&S Power Viewer. For information on installation, see the operating manual of the R&S Power Viewer.
2. Proceed as described in:
 - [Section 3.7.1.1, "Using a simple USB connection"](#), on page 19
 - [Section 3.7.1.2, "Using R&S NRP-Z5 sensor hub setup"](#), on page 20

Starting a measurement

For a detailed description, refer to the operating manual of the R&S Power Viewer. The manual is installed automatically during the installation of the R&S Power Viewer.

1. Start the R&S Power Viewer.
2. Turn off all test signals before zeroing. An active test signal during zeroing causes an error.
3. Execute zeroing.
4. Switch on the test signal of the signal source.
5. Select a measurement type.
6. Start the measurement.

5.7 R&S Power Viewer Mobile

The R&S Power Viewer Mobile extends the functionality of the R&S Power Viewer to Android-based devices, such as a smartphone and tablets.



For connecting the sensor to Android mobile phones with USB type C connector, use an R&S NRP-ZKC cable. It enables the R&S Power Viewer Mobile to take power measurements via the connection.

For further details, see [Section 3.7.2, "Android smartphone or tablet with USB type C"](#), on page 22.

You can download the R&S Power Viewer Mobile free of charge from the Google play store.

The 1MA215 "Using R&S®NRP Series Power Sensors with Android™ Handheld Devices" application note gives a detailed description on installation and features of the R&S Power Viewer Mobile. The application note is provided on the Rohde & Schwarz website. Search for "1MA215".

6 Web user interface

The web user interface is an alternative way to operate an LAN sensor.

This section provides a description of the parameters used for setting a power measurement with the web user interface.

For a detailed description of how to connect the sensor to a device and start the web user interface, refer to [Section 5.2, "Web user interface"](#), on page 37.

6.1 Main dialog of the web user interface

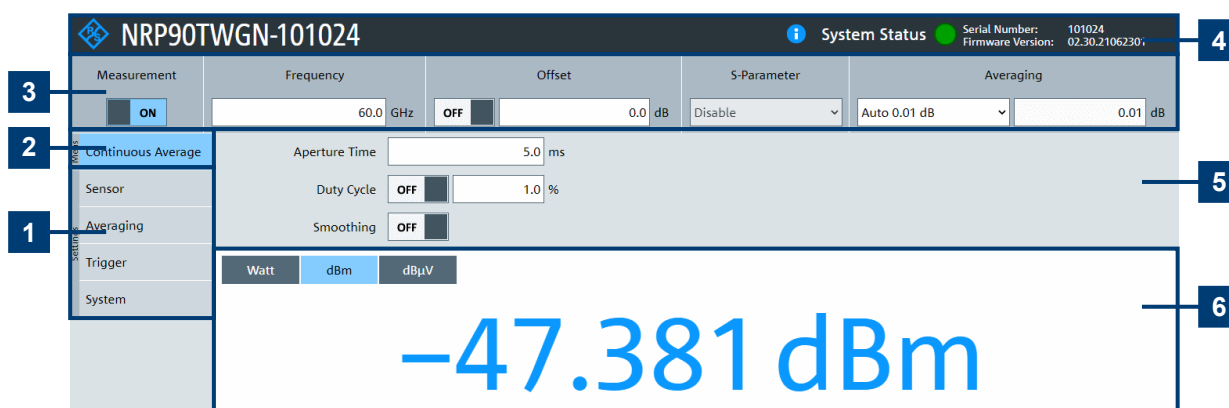

Figure 6-1: Explanation of the web user interface

- 1 = Navigation pane - "Settings", see [Section 6.5, "Settings"](#), on page 46
- 2 = Navigation pane - "Measurements", see [Section 6.4, "Measurement modes"](#), on page 45
- 3 = Common settings, see [Section 6.3, "Common settings"](#), on page 43
- 4 = Title bar
- 5 = Parameter pane
- 6 = Result pane

Title bar

Shows the following information:

- R&S logo
If you click the R&S logo, the Rohde & Schwarz homepage is displayed on a new browser tab.
- Sensor name or host name
If you click the name, the product page of the sensor is displayed on a new browser tab.
See also [Section 3.7.4.3, "Using host names"](#), on page 28.
- System status
Confirms that there is a connection between the sensor and the remote computer and that the sensor is recognized by the software. The presentation of this symbolic LED mirrors the physical LED of the sensor. See [Section 4.2, "Status information"](#), on page 31.

Parameter pane

Displays the content selected in the navigation pane.

Result pane

Displays the measurement result for the selected measurement mode. It can display only a value or a graph, depending on the selected measurement mode.

6.2 Setting the unit

If a parameter has a unit, the unit is displayed after the value.



Figure 6-2: Parameter

- 1 = Parameter name
- 2 = Value
- 3 = Unit

You can set the unit for the different parameters by typing the corresponding letter after the entered value.

Example:

To set the unit to 1 GHz, enter *1g*.

The following abbreviations are available:

Unit	Keyboard key
Decibel	<i>db</i>
Decibel-milliwatts	<i>dbm</i>
Hertz	<i>h</i>
Second	<i>s</i>
Volt	<i>v</i>
Watts	<i>w</i>

Unit multiples	Keyboard key
Giga	<i>g</i>
Mega	<i>m</i>
Kilo	<i>k</i>
milli	<i>m</i>

Unit multiples	Keyboard key
micro	<i>u</i>
nano	<i>n</i>

For certain parameters, you can select a different representation, depending on the requirements. For example, for the representation of the trigger level, you can choose Watts, dBm or dB μ V. To change the unit, you must specify the desired value together with the full new unit once.

Example:

To change the representation of a trigger level of 100 μ W into dBm, enter *-10dbm* in the "Trigger Level" field. All future entries of solely numbers represent the value in dBm. Thus, if you enter *-15* in the field, the "Trigger Level" value is set to -15.00 dBm.

If you want to revert the value to Watts, enter *50uw*. The "Trigger Level" value is set a value of 50.00 μ W, thus changing the unit for the further numeric entries.

6.3 Common settings

Describes the common settings that are available for all measurement modes.

Access: main dialog of the web user interface > top pane

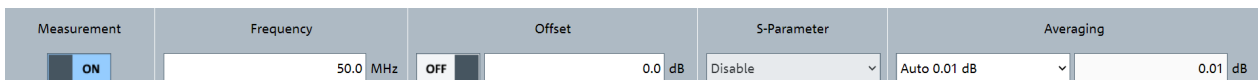

Measurement.....	43
Frequency.....	43
Offset.....	44
L <State>.....	44
L <Value>.....	44
S-Parameter.....	44
Averaging.....	44
L <Mode>.....	44
L <Value>.....	44

Measurement

Enables or disables the measurement.

Remote command:

`INITiate:CONTinuous`

Frequency

Sets the carrier frequency of the applied signal. This value is used for frequency response correction of the measurement result.

Remote command:

`[SENSe<Sensor>:] FREQuency`

Offset

Groups the offset settings.

<State> ← Offset

Enables or disables the usage of the level offset.

Remote command:

```
[SENSe<Sensor>:]CORRection:OFFSet:STATe
```

<Value> ← Offset

Adds a fixed level offset in dB to account for external losses.

Remote command:

```
[SENSe<Sensor>:]CORRection:OFFSet
```

S-Parameter

Enables or disables the S-parameter corrections. S-parameters are used to compensate for a component (attenuator, directional coupler) connected ahead of the sensor. See also [Section 8.6.3.3, "S-parameter correction"](#), on page 89.

Averaging

Groups the averaging settings. See also [Section 8.6.1, "Configuring auto averaging"](#), on page 82.

<Mode> ← Averaging

Sets the averaging mode.

"Manual" Disables auto averaging. Enter the average count under "**<Value>**" on page 44.

"Auto 1 dB" / "Auto 0.1 dB" / "Auto 0.01 dB" / "Auto 0.001 dB"
 Uses an automatic averaging filter with the respective resolution index.

 Predefines the compliance to an exactly defined noise component. Enter this value under "**<Value>**" on page 44.

Remote command:

```
[SENSe<Sensor>:]AVERAge [:STATe]
```

```
[SENSe<Sensor>:]AVERAge:COUNT:AUTO
```

```
[SENSe<Sensor>:]AVERAge:COUNT:AUTO:TYPE
```

<Value> ← Averaging

The content of this field depends on the setting under "**<Mode>**" on page 44.

- If "Manual" is set:
 Sets the average count, also called averaging factor.
- If "Auto xx dB" is set:
 Displays the resolution index.
- If "Noise Content" is set:
 Sets the maximum noise ratio in the measurement result.

Remote command:

```
[SENSe<Sensor>:]AVERAge:COUNT
```

```
[SENSe<Sensor>:]AVERAge:COUNT:AUTO:RESolution
```

```
[SENSe<Sensor>:]AVERAge:COUNT:AUTO:NSRatio
```

6.4 Measurement modes

Describes the parameters for the available measurement modes.

- [Continuous average mode](#).....45

6.4.1 Continuous average mode

Describes the parameters of the continuous average measurement.

Further information:

- [Section 8.5.1, "Continuous average measurement"](#), on page 80
Detailed description of the continuous average mode and its remote commands

Access: main dialog of the web user interface > navigation pane > "Continuous Average"

Aperture Time	<input type="text" value="20.0"/>	ms
Duty Cycle	<input type="checkbox"/> OFF <input type="text" value="1.0"/>	%
Smoothing	<input type="checkbox"/> OFF	

Aperture Time	45
Duty Cycle	45
Smoothing	46

Aperture Time

Sets the aperture time, the width of the sampling windows.

Remote command:

```
[SENSe<Sensor>:] [POWER:] [AVG:] APERture on page 81
```

Duty Cycle

Sets the duty cycle, the percentage of one period during which the signal is active, for pulse modulated signals. If the duty cycle is set, the sensor calculates the signal pulse power from its value and the average power.

Remote command:

```
[SENSe<Sensor>:]CORRection:DCYCLe:STATe
```

```
[SENSe<Sensor>:]CORRection:DCYCLe
```

Smoothing

Enables the smoothing filter, a steep-cut off digital lowpass filter. The filter reduces result fluctuations caused by modulation.

Remote command:

```
[SENSe<Sensor>:] [POWer:] [AVG:] SMOothing:STATe
```

6.5 Settings

Describes the parameters for general configuration.

- [Sensor settings](#)..... 46
- [Averaging settings](#)..... 47
- [Trigger settings](#)..... 48
- [System settings](#)..... 50

6.5.1 Sensor settings

Describes the parameters for optimizing the measurement results for specific measurement requirements.

Further information:

- [Section 8.6.3, "Configuring corrections"](#), on page 87
- [Section 8.9, "Calibrating, zeroing"](#), on page 107
- [Section 8.10, "Running a self-test"](#), on page 110

Access: main dialog of the web user interface > navigation pane > "Sensor"

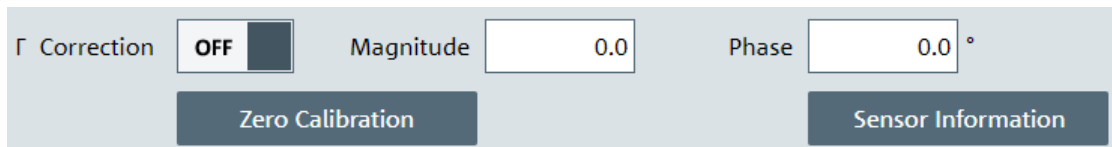

- [Gamma Correction](#)..... 46
 - └ [<State>](#)..... 46
 - └ [Magnitude](#)..... 47
 - └ [Phase](#)..... 47
- [Zero Calibration](#)..... 47
- [Sensor Information](#)..... 47

Gamma Correction

Groups the parameters for the complex reflection coefficient. See also [Section 8.6.3.4, "S-gamma corrections"](#), on page 90.

<State> ← **Gamma Correction**

Enables or disables the use of the complex reflection coefficient of the signal source,

Γ_{source}

Remote command:

[SENSe<Sensor>:] SGAMma:CORRection:STATE

Magnitude ← Γ Correction

Sets the magnitude of the complex reflection coefficient of the source, Γ_{source} .

A value of 0.0 corresponds to an ideal matched source. A value of 1.0 corresponds to total reflection.

Remote command:

[SENSe<Sensor>:] SGAMma:MAGNitude

Phase ← Γ Correction

Sets the phase angle of the complex reflection coefficient of the source, Γ_{source} .

Remote command:

[SENSe<Sensor>:] SGAMma:PHASe

Zero Calibration

Performs zeroing using the signal at the sensor input. See [Section 8.9, "Calibrating, zeroing"](#), on page 107.

Note:

Turn off all test signals before zeroing. An active test signal during zeroing causes an error.

Remote command:

CALibration<Channel>:ZERO:AUTO

Sensor Information

Displays information on the sensor.

- General information: manufacturer, sensor type, stock number, serial number, firm-ware version
- Network settings: MAC address, host name, IP address, sensor name. A part of them, you can configure under [Section 6.5.4, "System settings"](#), on page 50.
- Important specifications: technology, frequency range, power limits, resolution, ...
- Calibration information

Remote command:

SYSTem:INFO?

6.5.2 Averaging settings

Describes the parameters for automatic averaging.

Further information:

- [Section 8.6.1, "Configuring auto averaging"](#), on page 82

Access: main dialog of the web user interface > navigation pane > "Averaging"

Filter Terminal Control	<input checked="" type="radio"/> Repeating	<input type="radio"/> Moving
Auto Measurement Time	<input type="text" value="4.0"/>	s

Filter Terminal Control.....	48
Auto Measurement Time.....	48

Filter Terminal Control

Defines how the measurement results are output, also called termination control. See also [Section 8.4, "Controlling the measurement"](#), on page 66.

- "Moving" Outputs intermediate values to facilitate early detection of changes in the measured quantity. In the settled state that means when the number of measurements specified by the averaging factor has been performed, a moving average is output.
- "Repeating" Specifies that a measurement result is not output until the entire measurement has been completed. That means that the number of measurement cycle repetitions is equal to the set averaging factor. If the averaging factor is large, the measurement time can be long.

Remote command:

`[SENSe<Sensor>:]AVERAge:TCONtrol`

Auto Measurement Time

Available only if "Noise Content" is set under "[<Mode>](#)" on page 44.

Sets an upper limit for the settling time of the auto-averaging filter, thus limiting the length of the filter.

Remote command:

`[SENSe<Sensor>:]AVERAge:COUNT:AUTO:MTIME`

6.5.3 Trigger settings

Describes the trigger parameters. You can define the conditions that have to be fulfilled for a measurement to be triggered.

Further information:

- [Section 8.4.5, "Configuring the trigger"](#), on page 74
- [Section 8.4, "Controlling the measurement"](#), on page 66

Access: main dialog of the web user interface > navigation pane > "Trigger"

Trigger Source	<input type="text" value="Immediate"/> 	Dropout	<input type="text" value="0.0"/> s
Trigger Level	<input type="text" value="1.0"/> μW	Holdoff	<input type="text" value="0.0"/> s
Trigger Delay	<input type="text" value="0.0"/> s	Hysteresis	<input type="text" value="0.0"/> dB

Trigger Source.....	49
L <Source>.....	49
L <Slope>.....	49
Trigger Level.....	49
Trigger Delay.....	49
Dropout.....	49
Holdoff.....	49
Hysteresis.....	50

Trigger Source

Groups the trigger source settings.

<Source> ← Trigger Source

Selects the trigger source. See [Section 8.4.2.3, "Trigger sources"](#), on page 68.

Remote command:

`TRIGger:SOURCE`

<Slope> ← Trigger Source

Sets the polarity of the active slope of the trigger signal that is externally or internally applied.

"Positive" The rising edge of the trigger signal is used for triggering.

"Negative" The falling edge of the trigger signal is used for triggering.

Remote command:

`TRIGger:SLOPe`

Trigger Level

Sets the trigger threshold for internal triggering derived from the test signal.

Remote command:

`TRIGger:LEVel` on page 77

`TRIGger:LEVel:UNIT` on page 78

Trigger Delay

Sets the delay between the trigger event and the beginning of the actual measurement.

Note: In continuous average mode, a negative trigger delay is not supported.

Remote command:

`TRIGger:DELaY`

Dropout

With a positive (negative) trigger slope, the dropout time is the minimum time for which the signal must be below (above) the power level defined by "Trigger Level". See also [Section 8.4.2.4, "Dropout time"](#), on page 69.

Remote command:

`TRIGger:DTIME`

Holdoff

Sets the holdoff time, a period after a trigger event during which all trigger events are ignored. See also [Section 8.4.2.5, "Holdoff time"](#), on page 70.

Remote command:

`TRIGger:HOLDoff`

Hysteresis

Sets the hysteresis in dB. A trigger event occurs, if the trigger level:

- Falls below the set value on a rising slope.
- Rises above the set value on a falling slope.

Thus, you can use this setting to eliminate the effects of noise in the signal for the edge detector of the trigger system.

Remote command:

`TRIGger:HYSTeresis`

6.5.4 System settings

Describes the parameters of the general network environment and specific identification parameters of the sensor in the network.

Further information:

- [Section 8.11, "Configuring the system"](#), on page 110

Access: main dialog of the web user interface > navigation pane > "System"

IP Address	<input type="text" value="192.168.1.1"/>	Gateway	<input type="text" value="192.168.1.1"/>	Apply Network Settings
Subnet Mask	<input type="text" value="255.255.255.0"/>	DHCP	<input checked="" type="radio"/> Auto <input type="radio"/> Static	Firmware Update...
Sensor Name	<input type="text" value="NRP33SN-900004"/>	Selftest		RST Reboot

IP Address	50
Subnet Mask	50
Sensor Name	51
Gateway	51
DHCP	51
Selftest	51
Apply Network Settings	52
Firmware Update	52
RST	52
Reboot	53

IP Address

Sets the IP address of the sensor.

Remote command:

`SYSTem:COMMunicate:NETWork:IPADdress`

Subnet Mask

Sets the subnet mask.

The subnet mask consists of four number blocks separated by dots. Every block contains 3 numbers in maximum.

Remote command:

```
SYSTem:COMMunicate:NETWork:IPAdDress:SUBNet:MASK
```

Sensor Name

Sets the sensor name. The sensor name is displayed in the title bar of the web user interface, see [Figure 6-1](#).

If you do not specify a sensor name, the host name is used as default. See also [SYSTem:COMMunicate:NETWork\[:COMMON\]:HOSTName](#) on page 114.

Remote command:

```
SYSTem[:SENSor]:NAME
```

Gateway

Sets the address of the default gateway that means the router that is used to forward traffic to destinations beyond the local network. This router is on the same network as the instrument.

Remote command:

```
SYSTem:COMMunicate:NETWork:IPAdDress:GATeway
```

DHCP

Selects how the IP address is assigned.

- | | |
|----------|---|
| "Auto" | Assigns the IP address automatically, provided the network supports DHCP (dynamic host configuration protocol). |
| "Static" | Enables assigning the IP address manually. |

Remote command:

```
SYSTem:COMMunicate:NETWork:IPAdDress:MODE
```

Selftest

Starts a self-test of the sensor. See also [Section 8.10, "Running a self-test"](#), on page 110.

Note:

Do not apply a signal to the sensor while the self-test is running. If the self-test is carried out with a signal being present, error messages can erroneously be output for the following test steps:

- Offset Voltages
- Noise Voltage

After the self-test is completed, the results are displayed.

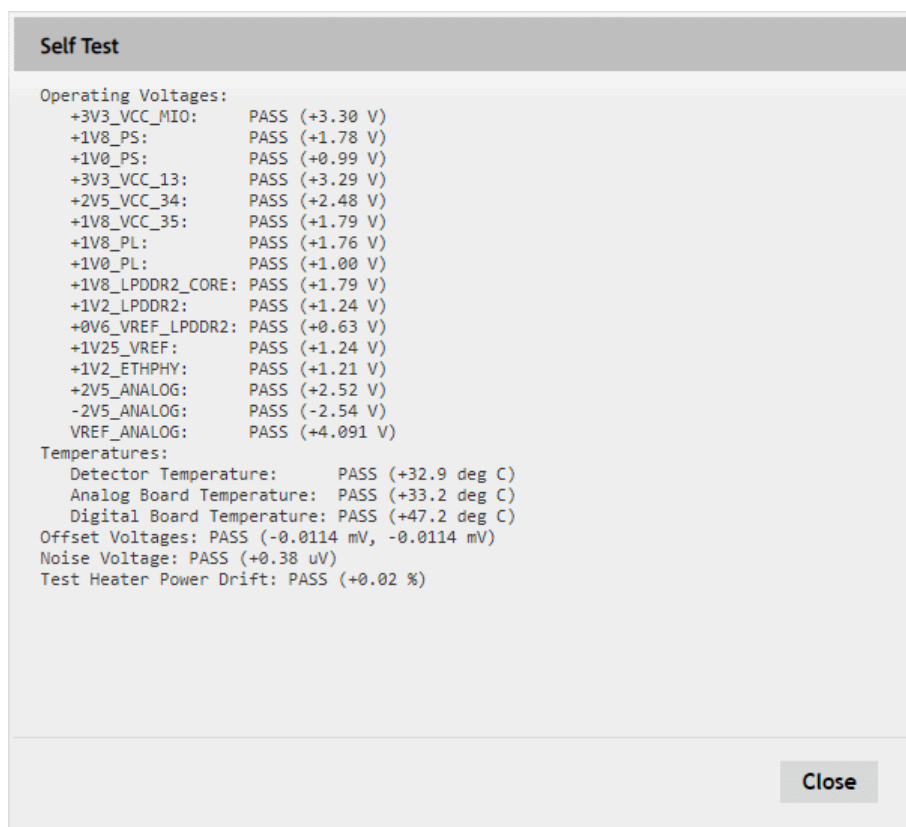

Remote command:

`TEST:SENSor?`

Apply Network Settings

After you have made the required network settings changes, apply them to the sensor by clicking "Apply Network Settings".

Firmware Update

Opens a dialog to start the firmware update. For further information, see [Section 7.2.2, "Using the web user interface"](#), on page 56.

Alternatively, you can the Firmware Update program. See [Section 7.2.1, "Using the Firmware Update program"](#), on page 54.

Remote command:

`SYSTEM:FWUPDATE`

`SYSTEM:FWUPDATE:STATUS?`

RST

Performs a preset. The R&S NRPxTWG(N) stops the running measurement, changes to the continuous average measurement and awaits the start of a new measurement.

Remote command:

`*RST`

Reboot

Reboots the R&S NRPxTWG(N). When the reboot is completed, press [F5] to reload the browser page.

Remote command:

[SYSTem:REBoot](#) on page 111

7 Firmware update

- [Downloading the firmware update file](#)..... 54
- [Updating the firmware](#)..... 54

7.1 Downloading the firmware update file

Firmware update files of R&S sensors generally have an RSU extension, RSU meaning Rohde & Schwarz update.

To download the RSU file

1. Download the most recent firmware version from the Rohde & Schwarz homepage on the internet. The latest firmware update files are available at:
www.rohde-schwarz.com/firmware/nrp-t-tn
2. Save the RSU file on the computer.
3. If the RSU file is packed in a *.zip archive, extract it.

7.2 Updating the firmware

Do not interrupt the firmware update because an interruption can lead to missing or faulty firmware. Take special care not to disconnect the power supply while the update is in progress. Interrupting the power supply during the firmware update most likely leads to an unusable sensor that needs to be sent in for maintenance.

You can choose from several methods to update the firmware installed on the sensor.



If you want to downgrade to an older version, you cannot use an RSU file downloaded from the Rohde & Schwarz homepage on the internet. Contact our customer support to receive a special downgrade file for your sensor. See [Section 12.7, "Contacting customer support"](#), on page 156.

7.2.1 Using the Firmware Update program

The Firmware Update program is part of the R&S NRP-Toolkit. See also [Section 5.1, "R&S NRP-Toolkit"](#), on page 34.



You can use the Firmware Update program only if the sensor is recognized as a VISA device.

To check the prerequisites

1. Ensure that a recent VISA software is installed on the computer.
The latest version is provided on the Rohde & Schwarz website at www.rohde-schwarz.com/rsvisa.
2. Ensure that the R&S NRP-Toolkit for Windows is installed on the computer. See [Section 5.1, "R&S NRP-Toolkit"](#), on page 34.

To update the firmware over USB

A firmware update can take up to 5 minutes. Ensure that the update is not interrupted.

1. Ensure that the prerequisites are fulfilled. See ["To check the prerequisites"](#) on page 55.
2. Connect the sensor to the computer.
See [Section 3.7.1, "Computer"](#), on page 19.
3. Start the Firmware Update program:
"Start" menu > "NRP-Toolkit" > "Firmware Update".

The program automatically starts scanning for R&S sensors connected via USB. When the scan is completed, all recognized sensors are listed under "Device".

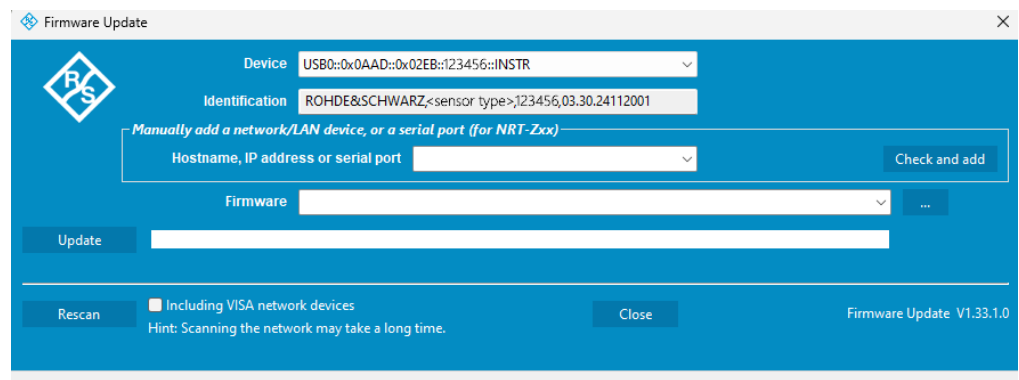

4. If the sensor you want to update is not listed, perform one of the following actions:
 - Click "Rescan" to search for attached sensors.
 - Check whether all necessary drivers are installed on the computer.
For example, if the VISA library is not installed on the computer, no VISA sensor is accessible.
See also [Section 12.4, "Problems during a firmware update"](#), on page 155 .
5. Under "Device", select the sensor you want to update.
Note: The "Hostname, IP Address or Serial Port" field is not used during this procedure. Therefore, leave it empty.
6. Under "Firmware", enter the full path and filename of the update file. Alternatively, click  next to the field.
7. Click "Update".
During the update process, a progress bar is displayed.

The update sequence can take a couple of minutes, depending on the sensor model and the size of the selected file.

8. Check if the update was successful. The firmware version in the "Identification" field must match the version you selected in the "Firmware" field.

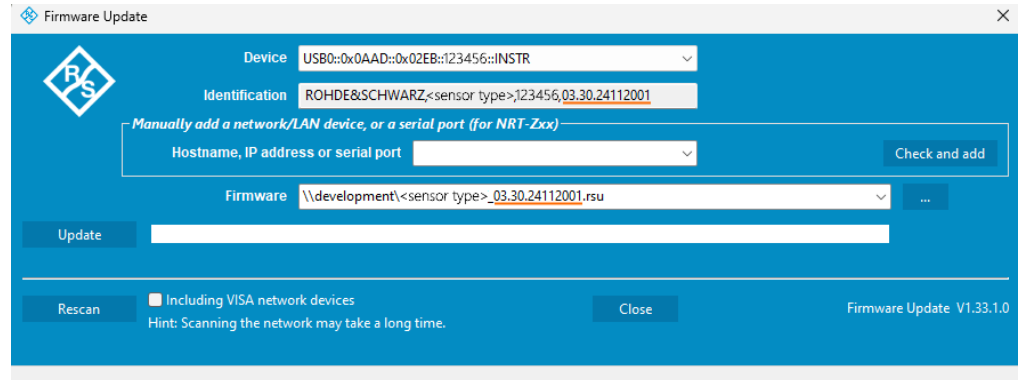

7.2.2 Using the web user interface

Requires a sensor with networking capabilities, a LAN sensor.

1. Connect the sensor to the computer as described in [Section 3.7.1, "Computer"](#), on page 19.
2. Open the web user interface as described in [Section 5.2, "Web user interface"](#), on page 37.
3. In the navigation pane, select "System".
4. Click "Firmware Update".
5. In the "Firmware Update" dialog, click "Select RSU file".
6. In the file browser, select the RSU file for upload.

The selected RSU file is displayed, for example `NRPxTN_03.30.24121801.rsu`.

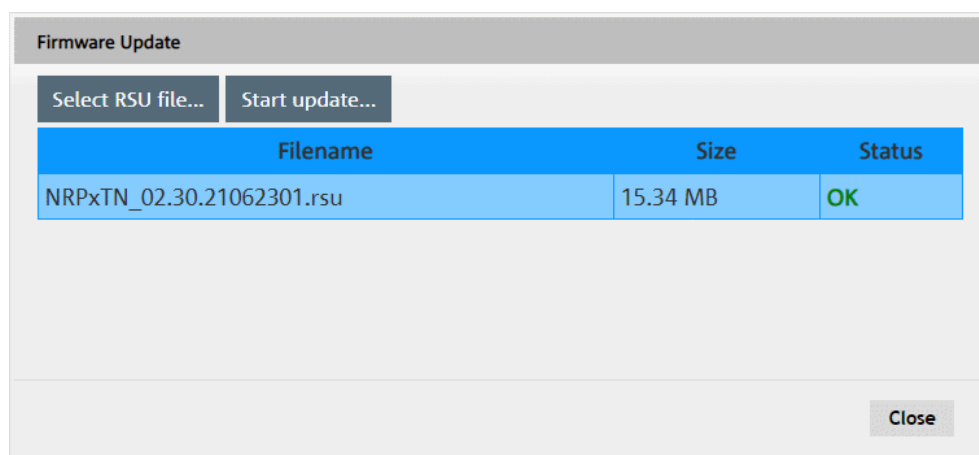

- Click "Start update".

The firmware update can take several minutes. During the update process, a progress bar is displayed. When the update is completed, the dialog closes automatically.

7.2.3 Using SCP or SFTP

Requires a sensor with networking capabilities, a LAN sensor.

You can transfer an update file by using either secure copy protocol (SCP) or secure file transfer protocol (SFTP).

To prepare for the transfer

- Connect the sensor to the computer on which you have saved the RSU file. See [Section 3.7.4, "Using a LAN connection"](#), on page 24.
- On the computer, open Command Prompt.
By default, your user directory on the computer is opened `C:/Users/<your name>`.

To transfer an update file by using SCP

- In Command Prompt, enter

```
scp <RSU file path> <user name>@<host name>:
/home/instrument/update
```

Example:

```
scp NRPxSN_03.50.25102101.rsu instrument@NRP33SN-999994:
/home/instrument/update
```
- Enter the password when prompted.

To transfer an update file by using SFTP

- In Command Prompt, enter `sftp <user name>@<host name>`.

Example: `sftp instrument@nrp33SN-999994`

2. Enter the password when prompted.
Connection is confirmed with "Connected to <host name>."
3. Change to the sensor update directory:
`cd /home/instrument/update`
4. Copy the new RSU file into the update directory of the sensor:
`put <RSU file path> <user name>@<host name>`
Example: `put NRPxSN_03.50.25102101.rsu`
`instrument@nrp33SN-999994`
5. If you want to display the list of the available commands, enter `help`.

Table 7-1: Input data explanations

Input data	Description
<user name>	User name of the sensor, preconfigured as <i>instrument</i> .
<host name>	See Section 3.7.4.3, "Using host names" , on page 28. Instead of the host name, you can use the IP address.
Password	User password configured with <code>SYSTem:SECurity:PASSword:USER</code> .
<RSU file path>	Path and name of the RSU file. If the RSU file is in your user directory on the computer <code>C:/Users/<your name></code> , the <RSU file path> is just the RSU filename, as shown in the example.

After the file transfer

When the copy process is completed, the firmware update starts automatically.

The files in the `update` directory are deleted automatically at every reboot.

7.2.4 Using remote control

If you want to integrate a firmware update function in an application, use `SYSTem:FWUPdate` on page 112.

Example:

You want to update the sensor with the `NRPxTN_03.30.24121801.rsu` file. This file has a size of 10242884 bytes.

To send the file to the sensor for updating the firmware, your application has to assemble a memory block containing:

```
SYST:FWUP <block_data>
```

The <block_data> are definite length-arbitrary block data.

See `SYSTem:FWUPdate` on page 112.

The size of the file is 10242884. This number has 8 digits. Thus, the `<block_data>` consist of the following:

- #
- 8
How many digits follow to specify the file size.
- 10242884
The number that specifies the file size.
- `<file_contents>`
Contents of the RSU file, byte-by-byte
- 0x0a
Delimiter

In this example, you write exactly 10242905 bytes to the sensor, for example by using a `'viWrite()'` function.

The 10242905 bytes result from the values of the list above:

$$9 + 1 + 1 + 1 + 8 + 10242884 + 1$$

In a (pseudo) string notation, the memory block looks like this:

```
SYST:FWUP #810242884<file_contents>0x0a,
```

8 Remote control commands

In the following, all implemented commands are listed according to the command system and then described in detail. Mostly, the notation used complies with SCPI specifications.

For general information on remote control of Rohde & Schwarz products via SCPI, refer to www.rohde-schwarz.com/rc-via-scp.

Further information:

- [Section 10.1, "Remote control interfaces and protocols"](#), on page 132
- [Section 10, "Remote control basics"](#), on page 132

8.1 Conventions used in SCPI command descriptions

The following conventions are used in the remote command descriptions:

- *Command usage*
If not specified otherwise, commands can be used both for setting and for querying parameters.
If a command can be used for setting or querying only, or if it initiates an event, the usage is stated explicitly.
- *Parameter usage*
If not specified otherwise, a parameter can be used to set a value, and it is the result of a query.
Parameters required only for setting are indicated as "Setting parameters".
Parameters required only to refine a query are indicated as "Query parameters".
Parameters that are only returned as the result of a query are indicated as "Return values".
- *Conformity*
Commands that are taken from the SCPI standard are indicated as "SCPI confirmed". All commands used by the R&S NRPxTWG(N) follow the SCPI syntax rules.
- *Asynchronous commands*
A command which does not automatically finish executing before the next command starts executing (overlapping command) is indicated as an "Asynchronous command".
- *Reset values (*RST)*
Default parameter values that are used directly after resetting the instrument (*RST command) are indicated as "*RST" values, if available.
- *Default unit*
The default unit is used for numeric values if no other unit is provided with the parameter.

Units

Units and prefixes, as defined by the international system of units (SI), are allowed and recognized. If you need decimal multiples and submultiples of a unit, you can use SCPI prefixes. Because SCPI uses only capital letters, it cannot distinguish between upper and lower case characters. Therefore, if SI prefixes use the same letter in upper and lower case, SCPI defines the meaning. An example is milli (m) and mega (M). In SCPI, M means milli for all units except Hz and Ohm - MHz means mega Hz, 10^6 Hz.

Table 8-1: SCPI prefixes

Factor	SI name	SI symbol	SCPI prefix
10^3	kilo	k	K
10^6	mega	M	MA; also allowed are MOHM and MHZ
10^9	giga	G	G
10^{12}	tera	T	T
10^{-3}	milli	m	M Exception: Hz and Ohm
10^{-6}	micro	μ	U
10^{-9}	nano	n	N
10^{-12}	pico	p	P

8.2 Common commands

The common commands are taken from the IEEE 488.2 (IEC 625–2) standard. The headers of these commands consist of an asterisk * followed by three letters.

*CLS.....	62
*ESE.....	62
*ESR?.....	62
*IDN?.....	62
*IST?.....	62
*OPC.....	63
*OPT?.....	63
*PRE.....	63
*RCL.....	63
*RST.....	63
*SAV.....	64
*SRE.....	64
*STB?.....	64
*TRG.....	64
*TST?.....	64
*WAI.....	65

***CLS**

Clear status

Resets the following:

- Status byte (STB)
- Standard event register (ESR)
- EVENT part of the QUESTIONABLE and the OPERATION register
- Error/event queue

The command does not alter the ENABLE and TRANSITION parts of the registers.

Usage: Event

***ESE <register>**

Event status enable

Sets the event status enable register to the specified value. The query returns the contents of the event status enable register in decimal form.

Parameters:

<register>	Range:	0 to 255
	*RST:	0

***ESR?**

Event status read

Returns the contents of the event status register in decimal form (0 to 255) and then sets the register to zero.

Usage: Query only

***IDN?**

Identification

Returns a string containing information on the identity of the sensor (device identification code). In addition, the version number of the installed firmware is indicated.

Usage: Query only

***IST?**

Individual status

Returns the current value of the IST flag in decimal form. The IST flag is the status bit which is sent during a parallel poll.

Usage: Query only

***OPC**

Operation complete

Sets bit 0 in the event status register when all preceding commands have been executed. Send this command at the end of a program message. It is important that the read timeout is set sufficiently long.

The query always returns 1 because the query waits until all previous commands are executed.

*OPC? basically functions like *WAI, but also returns a response. The response is an advantage, because you can query the execution of commands from a controller program before sending new commands. Thus preventing overflow of the input queue when too many commands are sent that cannot be executed.

***OPT?**

Option identification

Returns a comma-separated list of installed options.

Usage: Query only

***PRE <register>**

Parallel poll register enable

Sets the parallel poll enable register to the specified value or queries the current value.

Parameters:

<register>	Range:	0 to 255
	*RST:	0

***RCL <number>**

Recall

Calls the device state which has been stored with the *SAV command under the specified number.

Setting parameters:

<number>	Range:	0 to 9
	*RST:	0

Usage: Setting only

***RST**

Reset

Sets the instrument to a defined default status. The default settings are indicated in the description of commands.

The command corresponds to the `SYSTem:PRESet` command.

Usage: Event

Manual operation: See "RST" on page 52

***SAV** <number>

Save

Stores the current device state under the specified number.

Setting parameters:

<number>	Range:	0 to 9
	*RST:	0

Usage: Setting only

***SRE** <register>

Service request enable

Sets the service request enable register to the specified value. This command determines under which conditions a service request is triggered.

Parameters:

<register>	Range:	0 to 255
	*RST:	0

***STB?**

Status byte

Returns the contents of the status byte in decimal form.

Usage: Query only

***TRG**

Trigger

Triggers a measurement if the following conditions are met:

- Sensor is in the waiting for trigger state.
- Trigger source is set to BUS.

See `TRIGger:SOURce` BUS.

Usage: Event

***TST?**

Self-test

Triggers a self-test of the sensor and outputs the result. 0 indicates that no errors have occurred.

Usage: Query only

*WAI

Wait to continue

Prevents the execution of the subsequent commands until all preceding commands have been executed and all signals have settled.

Usage: Event

8.3 Preparing for the measurement

Before starting a measurement, you need to do the following:

- [Selecting the reference source](#)..... 65
- [Selecting a measurement mode](#)..... 66

8.3.1 Selecting the reference source

The `ROSCillator` subsystem contains commands for configuring the reference source.

[SENSe<Sensor>:]ROSCillator:SOURce <source>

Sets the source of the reference oscillator.

Refers typically to a precision, stabilized timebase.

Suffix:

<Sensor> 1

Parameters:

<source> INTernal | EXTernal | HOST

INTernal

Internal precision oscillator

EXTernal | HOST

External signal that is supplied at the host interface connector.

***RST:** If the sensor boots or reboots, the source is set to INTernal. If the sensor is reset, the source setting is kept unchanged.

Example: `ROSC:SOUR INT`

8.3.2 Selecting a measurement mode

Before starting a measurement, select the measurement mode.

Further information:

- The available measurement modes and how to configure them are described in [Section 8.5, "Configuring the measurement modes"](#), on page 80.

[SENSe<Sensor>:]FUNction <function>

Sets the measurement mode.

Suffix:

<Sensor> 1

Parameters:

<function> **"POWer:AVG"**
 Continuous average mode
 See [Section 8.5.1, "Continuous average measurement"](#),
 on page 80.
 *RST: "POWer:AVG"

8.4 Controlling the measurement

The sensor offers a bunch of possibilities to control the measurement:

- Do you want to start the measurement immediately after the initiate command or do you want to wait for a trigger event?
- Do you want to start a single measurement cycle or a sequence of measurement cycles?
- Do you want to output each new average value as a measurement result or do you want to bundle more measured values into one result?

8.4.1 Starting and ending a measurement

In a basic continuous measurement, the measurement is started immediately after the continuous measurement mode is enabled. If you want to start the measurement only if a specific condition is fulfilled, define a trigger.

Further information:

- [Section 8.4.2, "Triggering"](#), on page 68

ABORT.....	67
INITiate:ALL.....	67
INITiate[:IMMediate].....	67
INITiate:CONTinuous.....	67

ABORt

Immediately interrupts the current measurement.

If the measurement has been started as a single measurement (`INITiate[:IMMediate]`), the sensor goes into the idle state.

If a continuous measurement is in progress (`INITiate:CONTinuous ON`), the trigger system of the sensor enters the waiting for trigger state. When the trigger condition is met, a new measurement is immediately started.

See also [Section 8.4, "Controlling the measurement"](#), on page 66.

Usage: Event

INITiate:ALL**INITiate[:IMMediate]**

Starts a single measurement cycle. The sensor changes from the idle state to the waiting for trigger state. When the trigger condition is fulfilled, the sensor begins the measurement. Depending on the number of trigger events that are required, e.g. for averaging, the sensor enters the waiting for trigger state several times. Once the entire measurement is completed, a measurement result is available, and the sensor enters the idle state again.

Use this command only after the continuous measurement mode has been disabled using `INITiate:CONTinuous OFF`.

See also [Section 8.4, "Controlling the measurement"](#), on page 66.

Example: See [Section 9.2, "Performing a buffered continuous average measurement"](#), on page 129.

Usage: Event

INITiate:CONTinuous <state>

Enables or disables the continuous measurement mode. In continuous measurement mode, the sensor does not go into the idle state after a measurement has been completed, but immediately executes another measurement cycle.

See also [Section 8.4.2, "Triggering"](#), on page 68.

Parameters:

<state>

ON

Measurements are performed continuously. If a measurement is completed, the sensor does not return to the idle state but enters the waiting for trigger state again.

OFF

Ends the continuous measurement mode, and sets the sensor to the idle state.

*RST: OFF

Example: See [Section 9.2, "Performing a buffered continuous average measurement"](#), on page 129.

Manual operation: See ["Measurement"](#) on page 43

8.4.2 Triggering

If you want to start the measurement only if a specific condition is fulfilled, define a trigger. For example, if a signal level is exceeded, or in certain time intervals.

Further information:

- [Section 8.4.5, "Configuring the trigger"](#), on page 74

8.4.2.1 Trigger states

The sensor has trigger states to define the exact start and stop time of a measurement and the sequence of a measurement cycle. The following states are defined:

- **Idle**
The sensor performs no measurement. After powering on, the sensor is in the idle state.
- **Waiting for trigger**
The sensor waits for a trigger event that is defined by the trigger source. When the trigger event occurs, the sensor enters the measuring state.
- **Measuring**
The sensor is measuring data. It remains in this state during the measurement. When the measurement is completed, it exits this state immediately.

8.4.2.2 Waiting for a trigger event

Before a trigger can be executed, the sensor has to be set to the waiting for trigger state. Depending on the required number of measurement cycles, you use one of the following commands:

- `INITiate:CONTinuous`
A new measurement cycle is started automatically after the previous one has been terminated.
- `INITiate[:IMMediate]`
The number of measurement cycles is restricted.
If `TRIGger:COUNT 1` is set, the command starts a single measurement cycle that renders one result. Every time you send this command, a new measurement cycle is started.
Otherwise, as many measurement cycles are performed as determined by the trigger count.

8.4.2.3 Trigger sources

The possible trigger conditions and the execution of a trigger depend on the selected trigger source.

If the signal power exceeds or falls below a reference level set by the trigger level, the measurement is started after the defined delay time. Waiting for a trigger event can be skipped.

Trigger source	Description	Remote commands to initiate the measurement
"Hold"	Triggered by the remote command.	TRIGger:IMMediate
"Immediate"	Measures immediately, does not wait for a trigger condition.	-
"Internal"	Uses the input signal as the trigger signal.	TRIGger:IMMediate
"External 1"	Uses the digital input signal supplied using a differential pair in the 8-pin sensor cable.	TRIGger:IMMediate
"External 2"	Uses the digital input signal supplied at the SMB connector.	TRIGger:IMMediate
"Bus"	Triggered by the remote command.	*TRG TRIGger:IMMediate

8.4.2.4 Dropout time

The dropout time is useful when dealing with signals with several active slots, for example GSM signals, see [Figure 8-1](#). When measuring in sync with the signal, a trigger event is to be produced at A, but not at B or C.

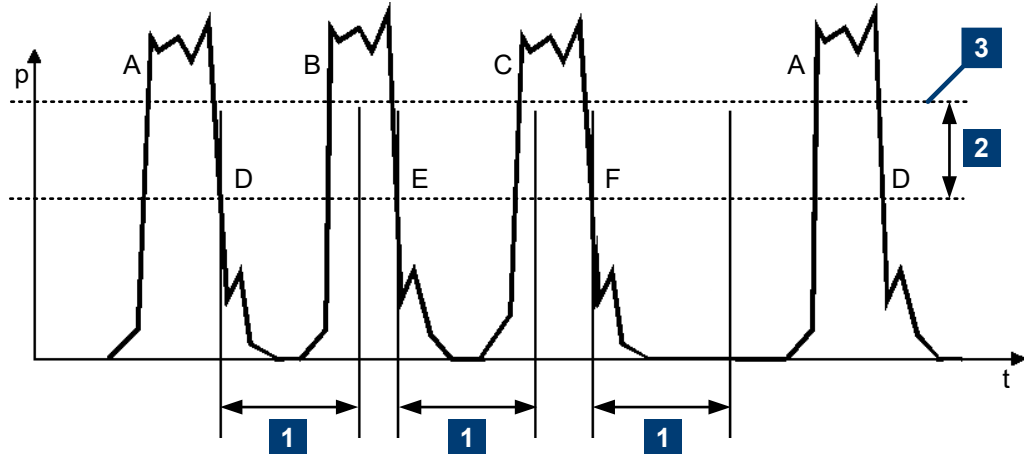

Figure 8-1: Significance of the dropout time

- 1 = Dropout time
- 2 = Trigger hysteresis
- 3 = Trigger level

The RF power between the slots is below the threshold defined by the trigger level and the trigger hysteresis. Therefore, the trigger hysteresis alone cannot prevent triggering at B or at C. Therefore, set the dropout time greater than the time elapsed between points D and B and between E and C, but smaller than the time elapsed between F and A. Thus, you ensure that triggering takes place at A.

Because the mechanism associated with the dropout time is reactivated whenever the trigger threshold is crossed, you can also obtain unambiguous triggering for many complex signals.

If you use a holdoff time instead of a dropout time, you can obtain stable triggering conditions, regular triggering at the same point. But you cannot achieve exclusive triggering at A.

8.4.2.5 Holdoff time

During the holdoff time, a period after a trigger event, all trigger events are ignored.

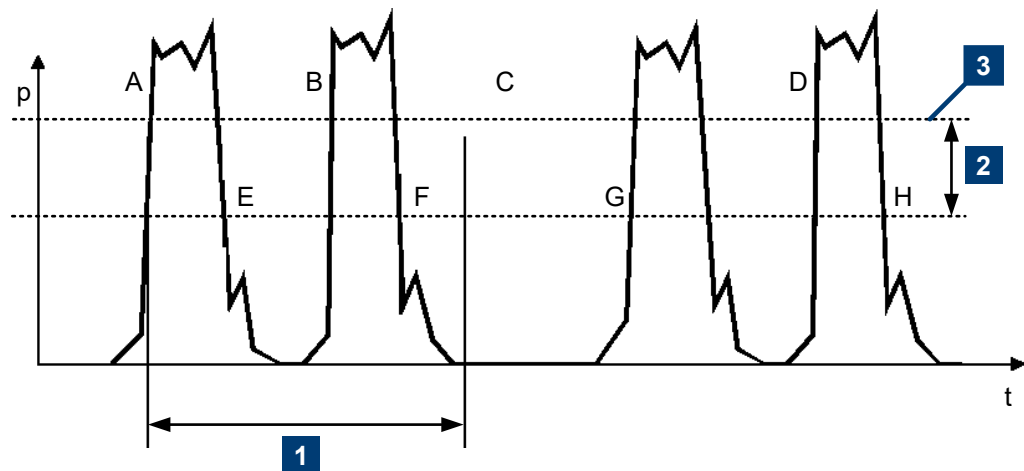

- 1 = Holdoff time
- 2 = Trigger hysteresis
- 3 = Trigger level

8.4.3 Controlling the measurement results

The sensor can cope with the wide range of measurement scenarios with the help of the "termination control". Depending on how fast your measurement results change, you can define how the measurement results are output.

In continuous average mode, use `[SENSe<Sensor>:]AVERage:TCONtrol`.

Repeating termination control

Outputs a measurement result when the entire measurement has been completed. This means that the number of measurement cycle repetitions is equal to the set average count. If the average count is large, the measurement time can be long.

Useful if you expect slow changes in the results, and you want to avoid outputting redundant data.

Moving termination control

Outputs intermediate values to facilitate early detection of changes in the measured quantity. This means that for each partial measurement, a new average value is output as a measurement result. Thus, the measurement result is a moving average of the last partial measurements. How many of the partial measurements are averaged is defined by the average count.

Useful if you want to detect trends in the result during the measurement.

8.4.4 Interplay of the controlling mechanisms

In the following examples, continuous measurement scenarios are used. But these scenarios also apply to single measurements. The only difference is that a single measurement is not repeated.

8.4.4.1 Continuous average mode

General settings for these examples:

- `INITiate:CONTinuous ON`
- `[SENSe<Sensor>:]AVERage:COUNT 4`
- `[SENSe<Sensor>:]AVERage:COUNT:AUTO OFF`

Example: Repeating termination control

Further settings for this example:

- `[SENSe<Sensor>:]AVERage:TCONtrol REPEAT`

The measurement is started by the trigger event.

Due to the chopper phases, one measurement lasts twice the defined aperture time.

As defined by the average count, after 4 measurements, the result is averaged and available. During the whole measurement cycle, the trigger synchronization is high (`TRIGger:SYNC:STATe ON`).

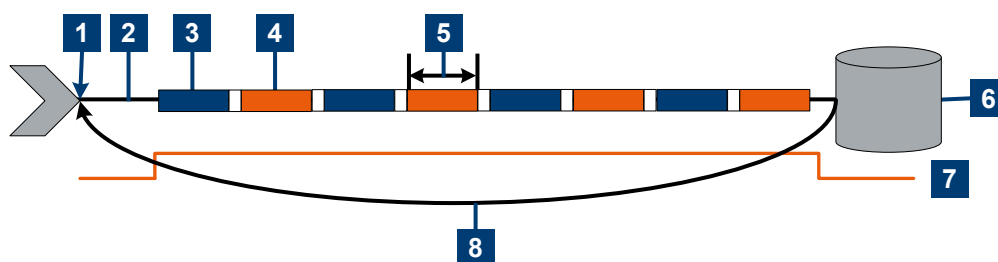

- 1 = Start of the measurement cycle
- 2 = Trigger event
- 3 = Noninverted chopper phase
- 4 = Inverted chopper phase
- 5 = Duration of one aperture time ($1 \times t_{AP} \triangleq$ length of one chopper phase)
- 6 = Measurement result
- 7 = Trigger synchronization
- 8 = Return to the start of the measurement cycle

Example: Moving termination control

Further settings for this example:

- `[SENSe<Sensor>:]AVERAge:TCONTRol MOVing`
- `TRIGger:COUNT 16`

Every measurement is started by a trigger event.

Due to the chopper phases, one measurement lasts twice the defined aperture time.

During each measurement, the trigger synchronization is high (`TRIGger:SYNC:STATe ON`). Every measurement provides a result. During the settling phase, the amount of the result is already correct, but the noise is higher. After 4 measurements, when the average count is reached, settled data is available.

When the trigger count is reached (`TRIGger:COUNT` on page 75), the sensor returns to the idle state.

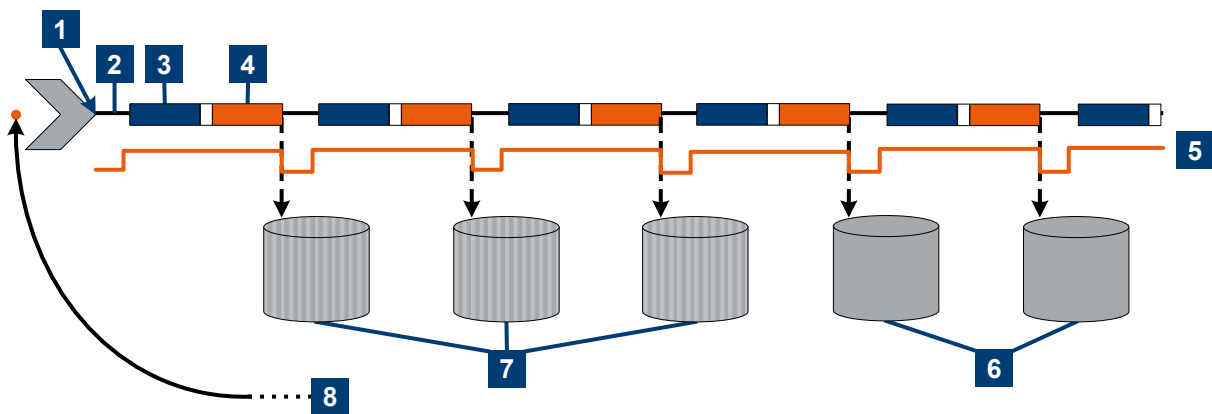

- 1 = Start of the measurement cycle
- 2 = Trigger events
- 3 = Noninverted chopper phase
- 4 = Inverted chopper phase
- 5 = Trigger synchronization
- 6 = Averaged measurement result after the average count is reached
- 7 = Measurement result before average count is reached
- 8 = Return to idle state after the trigger count (= 16 in this example) is reached

Example: Average count = 1

```
[SENSe<Sensor>:]AVERAge:COUNT 1
```

For average count 1, the setting of the termination control has no impact. In both cases, the measurement runs for the duration of one aperture time. Then, settled data is available, and the sensor returns to the idle state.

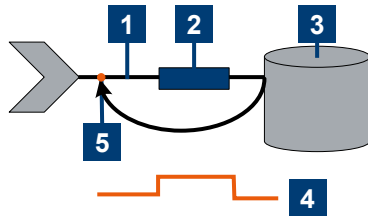

- 1 = Trigger event
- 2 = Noninverted chopper phase
- 3 = Measurement result
- 4 = Trigger synchronization
- 5 = Return to idle state

8.4.5 Configuring the trigger

Further information:

- [Section 8.4, "Controlling the measurement"](#), on page 66

Remote commands:

TRIGger:ATRigger:DELay	74
TRIGger:ATRigger:EXECuted?	75
TRIGger:ATRigger[:STATe]	75
TRIGger:COUNt	75
TRIGger:DELay	76
TRIGger:DELay:AUTO	76
TRIGger:DTIME	76
TRIGger:EXTErnal<2...2>:IMPedance	76
TRIGger:HOLDoff	77
TRIGger:HYSTeresis	77
TRIGger:IMMEdiate	77
TRIGger:LEVel	77
TRIGger:LEVel:UNIT	78
TRIGger:SENDEr:PORT	78
TRIGger:SENDEr:STATe	79
TRIGger:SLOPe	79
TRIGger:SOURce	79
TRIGger:SYNC:PORT	79
TRIGger:SYNC:STATe	80

TRIGger:ATRigger:DELay <delay>

Effective only if [TRIGger:ATRigger\[:STATe\]](#) is set to ON.

Sets the delay between the artificial trigger event and the beginning of the actual measurement

Parameters:

<delay> Range: 0.1 s to 5.0 s
 *RST: 2.0 s
 Default unit: s

TRIGger:ATRigger:EXECuted?

Queries the number of measurements that were triggered automatically since `TRIGger:ATRigger[:STATe]` was set to ON.

In normal scalar measurements, this number can only be 0 or 1. If a buffered measurement was executed, this number indicates how many results in the returned array of measurement data were executed without a real trigger event.

Usage: Query only

TRIGger:ATRigger[:STATe] <state>

Controls the automatic trigger function. If enabled, an artificial trigger is generated if the delay time has elapsed after the measurement start, and no trigger event has occurred.

The delay time is set using `TRIGger:ATRigger:DELay`.

Parameters:

<state> *RST: OFF

TRIGger:COUNT <count>

Sets the number of measurement cycles to be performed when the measurement is started using `INITiate[:IMMediate]`.

This number equals the number of results that can be obtained from the sensor after a single measurement. As long as the defined number of measurements is not executed, the sensor automatically initiates another measurement internally when the current result is available.

This command is particularly useful in conjunction with buffered measurements. For example, to fill a buffer with a predefined size with measurements that have been triggered externally or by `*TRG` without having to start the measurement multiple times.

Parameters:

<count> Range: 1 to 8192
 *RST: 1

Example: See [Section 9.2, "Performing a buffered continuous average measurement"](#), on page 129.

TRIGger:DElay <delay>

Sets the delay between the trigger event and the beginning of the actual measurement (integration).

Parameters:

<delay> Range: -5.0 s to 10.0 s
 *RST: 0.0 s
 Default unit: s

Manual operation: See ["Trigger Delay"](#) on page 49

TRIGger:DElay:AUTO <state>

If [TRIGger:DElay:AUTO](#) ON is set, no measurement is started until the sensor has settled. For this purpose, the delay value is automatically determined.

If a longer period is set using [TRIGger:DElay](#), the automatically determined delay is ignored.

Parameters:

<state> *RST: OFF

TRIGger:DTIME <dropout_time>

Sets the dropout time for the internal trigger source. During this time, the signal power must exceed (negative trigger slope) or undercut (positive trigger slope) the level defined by the trigger level and trigger hysteresis. At least, this time must elapse before triggering can occur again.

See [Section 8.4.2.4, "Dropout time"](#), on page 69.

Parameters:

<dropout_time> Range: 0.00 s to 10.00 s
 *RST: 0.00 s
 Default unit: s

Manual operation: See ["Dropout"](#) on page 49

TRIGger:EXternal<2...2>:IMPedance <impedance>

Effective only if [TRIGger:SOURce](#) EXternal2 is set.

Sets the termination resistance of the second external trigger input. Choose the setting that fits the impedance of the trigger source to minimize reflections on the trigger signals.

Suffix:

<2...2> 1..n

Parameters:

<impedance> HIGH | LOW

HIGH
~10 kΩ

LOW
50 Ω

*RST: HIGH

TRIGger:HOLDoff <holdoff>

Sets the holdoff time, see [Section 8.4.2.5, "Holdoff time"](#), on page 70.

Parameters:

<holdoff> Range: 0.00 s to 10.00 s
 *RST: 0.00 s
 Default unit: s

Manual operation: See ["Holdoff"](#) on page 49

TRIGger:HYSteresis <hysteresis>

Sets the hysteresis. A trigger event occurs, if the trigger level:

- Falls below the set value on a rising slope.
- Rises above the set value on a falling slope

Thus, you can use this setting to eliminate the effects of noise in the signal for the edge detector of the trigger system.

Parameters:

<hysteresis> Range: 0.00 dB to 10.00 dB
 *RST: 0.00 dB
 Default unit: dB

Manual operation: See ["Hysteresis"](#) on page 50

TRIGger:IMMediate

Causes a generic trigger event. The sensor leaves the waiting for trigger state immediately, irrespective of the trigger source and the trigger delay, and starts the measurement.

This command is the only way to start a measurement if the trigger source is set to hold, `TRIGger:SOURce HOLD`. Only one measurement cycle is executed, irrespective of the averaging factor.

Usage: Event

TRIGger:LEVel <level>

Effective only if `TRIGger:SOURce INTernal`.

Sets the trigger threshold for internal triggering derived from the test signal.

If the S-parameter and/or the offset correction are enabled, the trigger threshold is referenced to the correction data.

If the S-parameter and/or the offset correction are disabled, the trigger threshold and its input limits are adjusted as necessary.

Parameters:

<level> If you enter a value without unit, the unit is defined by
[TRIGger:LEVel:UNIT](#).
 Range: 300e-9 W to 100.0e-3 W
 *RST: 3.0e-5 W
 Default unit: As defined by [TRIGger:LEVel:UNIT](#).

Manual operation: See "[Trigger Level](#)" on page 49

TRIGger:LEVel:UNIT <unit>

Defines the unit of the trigger level if this value is entered without a unit. See also [TRIGger:LEVel](#) on page 77.

Parameters:

<unit> DBM | W | DBUV
 *RST: W

Manual operation: See "[Trigger Level](#)" on page 49

TRIGger:SENDER:PORT <sender_port>

Effective only if the R&S NRPxTWG(N) is trigger sender:

- [TRIGger:SENDER:STATE](#) ON

Selects the port where the sensor outputs a digital trigger signal.

If the sensor is the trigger sender, it can output its trigger signal either on the [EXTernal<1>](#) or [EXTernal2](#).

If the sensor triggers itself, the trigger source of the sensor must be assigned to the other external port, as shown in the examples.

Parameters:

<sender_port> EXT1 | EXTernal1 | EXT2 | EXTernal2
 *RST: EXT1

Example:
 TRIG:SEND:PORT EXT1
 TRIG:SOUR EXT2
 TRIG:SEND:STAT ON

Example:
 TRIG:SEND:PORT EXT2
 TRIG:SOUR EXT1
 TRIG:SEND:STAT ON

TRIGger:SENDER:STATE <state>

Enables or disables the trigger sender mode of the sensor. In this state, the sensor can output a digital trigger signal in sync with its own trigger event.

If enabled, select the output port for the trigger signal using **TRIGger:SENDER:PORT**.

Typically, the trigger sender uses its internal trigger source. But you can also trigger the trigger sender externally, because the sensor has two external trigger connectors. If you trigger the trigger sender externally, use **EXTernal1** as external trigger input port (trigger source) and **EXTernal2** as trigger sender output port or vice versa.

Parameters:

<state> *RST: OFF

TRIGger:SLOPe <slope>

Effective only if **TRIGger:SOURce** is set to **INTernal** or **EXTernal**.

Determines which edge of the envelope power, with internal triggering, or increasing voltage, with external triggering, is used for triggering.

Parameters:

<slope> POSitive | NEGative
 POSitive
 Rising edge
 NEGative
 Falling edge
 *RST: POSitive

Manual operation: See "<Slope>" on page 49

TRIGger:SOURce <source>

Selects the source for the trigger event.

Parameters:

<source> HOLD | IMMEDIATE | INTernal | BUS | EXTernal | EXT1 |
 EXTernal1 | EXT2 | EXTernal2
 See [Section 8.4.2.3, "Trigger sources"](#), on page 68.
 *RST: IMMEDIATE

Manual operation: See "<Source>" on page 49

TRIGger:SYNC:PORT <sync_port>

Selects the external connection for the sync output of the sensor. For more information, see **TRIGger:SYNC:STATE**.

Parameters:

<sync_port> EXT1 | EXTernal1 | EXT2 | EXTernal2
 *RST: EXT1

TRIGger:SYNC:STATE <state>

Available if **TRIGger:SOURce IMMEDIATE** is set.

Enable the synchronization state if you want to synchronize several sensors connected to a base unit. The synchronization works as follows.

The external trigger bus is blocked as long as a sensor is in the "measuring" state. The external trigger bus is enabled only when all sensors are in the "waiting for trigger" or "idle" state. Thus, the sensors start to measure simultaneously.

Make sure that the measurement time is the same for all sensors involved in the measurement. Otherwise, the trigger bus is blocked by any sensor that has completed its measurement before the others and has returned to the "idle" state.

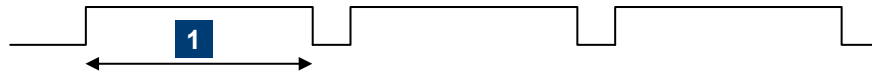

1 = measurement time

During the measurement, the trigger synchronization is high. For a continuous average measurement, the measurement time is calculated as described in [Section 8.5.1.4, "Calculating the measurement time"](#), on page 82.

For details on trigger states, see [Section 8.4.2.1, "Trigger states"](#), on page 68.

Parameters:

<state> *RST: OFF

8.5 Configuring the measurement modes

In the following, the settings needed for configuring a measurement mode are described.

Further information:

- [Section 8.6, "Configuring basic measurement parameters"](#), on page 82
- [Section 8.4, "Controlling the measurement"](#), on page 66
- [Section 8.8, "Querying measurement results"](#), on page 105

8.5.1 Continuous average measurement

The continuous average mode measures the signal average power asynchronously within definable time intervals (sampling windows). The aperture (width of the sampling windows) can be defined.

Further information:

- [Section 8.8, "Querying measurement results"](#), on page 105

8.5.1.1 Defining the sampling window

[SENSe<Sensor>:][POWER:][AVG:]APERture <integration_time>

Sets the duration of the sampling window. During this time interval, the average signal power is measured.

Suffix:

<Sensor> 1

Parameters:

<integration_time> Range: 0.5e-3 s to 0.3 s
 *RST: 0.005 s
 Default unit: s

Manual operation: See "[Aperture Time](#)" on page 45

8.5.1.2 Reducing noise and zero offset

The smoothing filter can reduce result fluctuations caused by modulation. But activating it increases the inherent noise of the sensor by approx. 20 %, so do not activate if it unless required.

[SENSe<Sensor>:][POWER:][AVG:]SMOothing:STATe <state>

Enables or disables the smoothing filter, a steep-edge digital lowpass filter. If you cannot adjust the aperture time exactly to the modulation period, the filter reduces result fluctuations caused by modulation.

Suffix:

<Sensor> 1

Parameters:

<state> ON | OFF
 *RST: OFF

Example: SMO:STAT OFF

Manual operation: See "[Smoothing](#)" on page 46

8.5.1.3 Measuring modulated signals

When measuring modulated signals in continuous average mode, the measurement can show fluctuation due to the modulation. If that is the case, adapt the size of the sampling window exactly to the modulation period to get an optimally stable display. If the modulation period varies or is not precisely known, you can also activate the smoothing function.

With smoothing activated, the selected sampling window has to be 5 to 9 times larger than the modulation period so that the fluctuations caused by modulation are sufficiently reduced. The sampling values are subjected to weighting (raised-von-Hann window), which corresponds to video filtering.

If you deactivate the smoothing filter, 300 to 3000 periods are required to obtain the same effect. The sampling values are considered equivalent and are averaged in a sampling window, which yields an integrating behavior of the measuring instrument. To obtain optimum suppression of variations in the result, exactly adapt the modulation period to the size of the sampling window. Otherwise, the modulation can have a considerable influence, even if the sampling window is larger than the modulation period.

8.5.1.4 Calculating the measurement time

Normally, the measurement time is calculated as follows:

$$MT = 2 * AC * APER + (2 * AC - 1) * 100 \mu s$$

With:

MT: overall measurement time

AC: average count

APER: aperture time

100 μ s is the time for switching the chopper phase.

8.6 Configuring basic measurement parameters

The following section describes the settings common for several measurement modes.

8.6.1 Configuring auto averaging

Describes the commands for automatic averaging in continuous average measurements.

Remote commands:

[SENSe<Sensor>:]AVERage:COUNT.....	83
[SENSe<Sensor>:]AVERage:COUNT:AUTO.....	83
[SENSe<Sensor>:]AVERage:COUNT:AUTO:MTIME.....	83
[SENSe<Sensor>:]AVERage:COUNT:AUTO:NSRatio.....	84
[SENSe<Sensor>:]AVERage:COUNT:AUTO:RESolution.....	84
[SENSe<Sensor>:]AVERage:COUNT:AUTO:TYPE.....	84
[SENSe<Sensor>:]AVERage:RESet.....	85
[SENSe<Sensor>:]AVERage[:STATe].....	85
[SENSe<Sensor>:]AVERage:TCONtrol.....	86

[SENSe<Sensor>:]AVERage:COUNT <count>

Sets the number of readings that are averaged for one measured value. The higher the count, the lower the noise, and the longer it takes to obtain a measured value.

Average count is often also called averaging factor, but it designates the same thing, i.e. the number of measured values that have to be averaged for forming the measurement result.

Averaging is only effective if `[SENSe<Sensor>:]AVERage[:STATe]` ON is set.

Suffix:

<Sensor> 1

Parameters:

<count> Range: 1 to 65536
*RST: 4

Example: AVER:COUNT 1

Manual operation: See "<Value>" on page 44

[SENSe<Sensor>:]AVERage:COUNT:AUTO <state>

Sets how the average count is determined.

Suffix:

<Sensor> 1

Parameters:

<state> **ON**
Auto averaging: the averaging factor is continuously determined and set depending on the power level and other parameters.

OFF
Fixed filter: the previous, automatically determined averaging factor is used.

ONCE
Automatically determines an averaging factor under the current measurement conditions. Then changes to the fixed filter setting (see OFF) and uses this averaging factor.

*RST: ON

Manual operation: See "<Mode>" on page 44

[SENSe<Sensor>:]AVERage:COUNT:AUTO:MTIME <maximum_time>

Sets an upper limit for the settling time of the auto-averaging filter if `[SENSe<Sensor>:]AVERage:COUNT:AUTO:TYPE` is set to NSRatio. Thus it limits the length of the filter.

If auto-averaging exceeded the maximum time, a notice is issued.

Suffix:

<Sensor> 1

Parameters:

<maximum_time> Range: 0.01 s to 999.99 s
 *RST: 4.00 s
 Default unit: s

Manual operation: See "[Auto Measurement Time](#)" on page 48

[SENSe<Sensor>:]AVERAge:COUNT:AUTO:NSRatio <nsr>

Determines the relative noise component in the measurement result for the measurement modes with scalar results. These measurement modes are continuous average, burst average and timeslot, provided the particular sensor supports them.

This command is only effective if the auto average calculation is enabled:

- [\[SENSe<Sensor>:\]AVERAge:COUNT:AUTO](#) ON
- [\[SENSe<Sensor>:\]AVERAge:COUNT:AUTO:TYPE](#) NSR

The noise component is defined as the magnitude of the level variation in dB caused by the inherent noise of the sensor (two standard deviations).

The query returns the relative noise component in the measured value.

Suffix:

<Sensor> 1

Parameters:

<nsr> Range: 100.000e-6 dB to 1.00 dB
 *RST: 0.01 dB
 Default unit: dB

Manual operation: See "[<Value>](#)" on page 44

[SENSe<Sensor>:]AVERAge:COUNT:AUTO:RESolution <resolution>

Defines the number of significant places for linear units and the number of decimal places for logarithmic units that are likely free of noise in the measurement result.

The setting is only considered if the following applies:

- [\[SENSe<Sensor>:\]AVERAge:COUNT:AUTO](#) ON
- [\[SENSe<Sensor>:\]AVERAge:COUNT:AUTO:TYPE](#) RES

Suffix:

<Sensor> 1

Parameters:

<resolution> Range: 1 to 4
 *RST: 3

Manual operation: See "[<Value>](#)" on page 44

[SENSe<Sensor>:]AVERAge:COUNT:AUTO:TYPE <type>

Sets the automatic averaging filter.

Suffix:

<Sensor> 1

Parameters:

<type> RESolution | NSRatio

RESolution

Usually used.

NSRatio

Predefines the compliance to an exactly defined noise component. Enter this value using `[SENSe<Sensor>:]AVERage:COUNT:AUTO:NSRatio`.

*RST: RESolution

Manual operation: See "[Mode](#)" on page 44**[SENSe<Sensor>:]AVERage:RESet**

Deletes all previous measurement results that the averaging filter contains and initializes the averaging filter. The filter length gradually increases from 1 to the set averaging factor. Thus, trends in the measurement result become quickly apparent. Note that the measurement time required for the averaging filter to settle completely remains unchanged.

Use this command if:

- High averaging factor is set.
`[SENSe<Sensor>:]AVERage:COUNT`
- Intermediate values are output as measurement results.
`[SENSe<Sensor>:]AVERage:TCONTROL MOVing`
- Power has significantly decreased since the previous measurement, for example by several powers of 10.

In this situation, previous measurement results, which are still contained in the averaging filter, strongly affect the settling of the display. As a result, the advantage of detecting trends in the measurement result while the measurement is still in progress is lost.

Suffix:

<Sensor> 1

Example:

AVER:RES

Usage:

Event

[SENSe<Sensor>:]AVERage[:STATE] <state>

Available in continuous average mode.

Enables or disables the averaging filter.

Suffix:

<Sensor> 1

Parameters:

<state> *RST: ON

Manual operation: See "[Mode](#)" on page 44

[SENSe<Sensor>:]AVERAge:TCONtrol <mode>

Defines how the measurement results are output. This is called termination control.

See also [Section 8.4.3, "Controlling the measurement results"](#), on page 70.

Suffix:

<Sensor> 1

Parameters:

<mode> MOVing | REPeat

MOVing

Outputs intermediate values to facilitate early detection of changes in the measured quantity. In the settled state that means when the number of measurements specified by the average count has been performed, a moving average is output.

REPeat

Specifies that a measurement result is not output until the entire measurement has been completed. This means that the number of measurement cycle repetitions is equal to the set average count. If the average count is large, the measurement time can be long.

The average count is set using [\[SENSe<Sensor>:\]AVERAge:COUNT](#) on page 83.

*RST: REPeat

Example:

AVER:TCON REP

Manual operation: See "[Filter Terminal Control](#)" on page 48

8.6.2 Setting the frequency

The frequency of the signal to be measured is not automatically determined. For achieving better accuracy, the carrier frequency of the applied signal must be set.

[SENSe<Sensor>:]FREQUency <frequency>

Transfers the carrier frequency of the RF signal to be measured. This frequency is used for the frequency response correction of the measurement result.

The center frequency is set for broadband signals, e.g. spread spectrum signals, multi-carrier signals.

Suffix:

<Sensor> 1

Parameters:

<frequency> Range: 0.0 Hz to Depends on the model. See the specifications document.
 *RST: 50.0e6 Hz
 Default unit: Hz

Example: FREQ 18000000

Manual operation: See "Frequency" on page 43

8.6.3 Configuring corrections

It is possible to set some parameters that compensate for a change of the measured signal due to fixed external influences.

- [Duty cycle corrections](#).....87
- [Offset corrections](#).....88
- [S-parameter correction](#).....89
- [S-gamma corrections](#).....90
- [I-gamma queries](#).....92
- [Using the S-Parameters program](#).....93

8.6.3.1 Duty cycle corrections

The duty cycle is the percentage of one period during which the signal is active, when pulse-modulated signals are corrected. The duty cycle is only evaluated in the continuous average mode.

Remote commands:

- [\[SENSe<Sensor>:\]CORRection:DCYClE](#).....87
- [\[SENSe<Sensor>:\]CORRection:DCYClE:STATe](#).....88

[SENSe<Sensor>:]CORRection:DCYClE <duty_cycle>

Available in continuous average mode.

Sets the duty cycle for measuring pulse-modulated signals. The duty cycle defines the percentage of one period during which the signal is active. If the duty cycle is enabled, the sensor considers this percentage when calculating the signal pulse power from the average power.

Suffix:

<Sensor> 1

Parameters:

<duty_cycle> Range: 0.001 percent to 100.00 percent
 *RST: 1.00 percent
 Default unit: PCT

Manual operation: See "Duty Cycle" on page 45

[SENSe<Sensor>:]CORRection:DCYClE:STATe <state>

Enables or disables the duty cycle correction for the measured value.

Suffix:

<Sensor> 1

Parameters:

<state> *RST: OFF

Manual operation: See "[Duty Cycle](#)" on page 45

8.6.3.2 Offset corrections

The offset accounts for external losses by adding a fixed level offset in dB.

The attenuation of an attenuator located ahead of the sensor (or the coupling attenuation of a directional coupler) is considered with a positive offset. That means the sensor calculates the power at the input of the attenuator or the directional coupler. A negative offset can be used to correct the influence of an amplifier connected ahead.

Using S-parameters instead of a fixed offset allows more precise measurements, because the interaction between the sensor and the component can be considered. See also [Section 8.6.3.3, "S-parameter correction"](#), on page 89.

Remote commands:

[\[SENSe<Sensor>:\]CORRection:OFFSet.....](#) 88
[\[SENSe<Sensor>:\]CORRection:OFFSet:STATe.....](#) 88

[SENSe<Sensor>:]CORRection:OFFSet <offset>

Sets a fixed offset that is added to correct the measured value.

Suffix:

<Sensor> 1

Parameters:

<offset> Range: -200.00 dB to 200.00 dB
*RST: 0 dB
Default unit: dB

Manual operation: See "[<Value>](#)" on page 44

[SENSe<Sensor>:]CORRection:OFFSet:STATe <state>

Enables or disables the offset correction.

Suffix:

<Sensor> 1

Parameters:

<state> *RST: OFF

Example: CORR:OFFS:STAT ON

Manual operation: See "<State>" on page 44

8.6.3.3 S-parameter correction

S-parameter correction compensates for the losses and reflections introduced by a component — such as an attenuator, directional coupler, or matching pad — that is attached to a sensor. Using S-parameters instead of a fixed offset increases measurement accuracy by accounting for the interaction between the sensor and the component. It shifts the reference plane of the sensor from its RF connector to the input of the device that is being applied externally.

The sensor allows compensating for the influence of any two-port device- between the signal source and the sensor input. As a result, the firmware can calculate the power that the signal source actually delivers. Examples of such two-port devices- include attenuators, matching pads, minimum-loss pads and waveguide adapters. One precondition for such compensation is that you provide a complete set of S-parameter data for the two-port device- in the frequency range required by the application.

Configuring the S-parameter correction

[SENSe<Sensor>:]CORRection:SPDevice:LIST?.....	89
[SENSe<Sensor>:]CORRection:SPDevice:SElect.....	89
[SENSe<Sensor>:]CORRection:SPDevice:STATe.....	89

[SENSe<Sensor>:]CORRection:SPDevice:LIST?

Queries the list of the S-parameter data sets that have been downloaded to the sensor. Returns the consecutive number and mnemonic of each data set, separated by line feeds.

Suffix:

<Sensor> 1

Usage: Query only

[SENSe<Sensor>:]CORRection:SPDevice:SElect <num>

Selects a downloaded data set for S-parameter correction.

Suffix:

<Sensor> 1

Parameters:

<num> Range: 1 to 1999
 *RST: 1; can differ if a calibration set defines another value.

[SENSe<Sensor>:]CORRection:SPDevice:STATe <state>

Enables or disables the S-parameter correction. If activated, uses the S-parameter data set selected by [SENSe<Sensor>:]CORRection:SPDevice:SElect.

Suffix:

<Sensor> 1

Parameters:

<state> *RST: OFF; can differ if a calibration set defines another value.

Example:

CORR:SPD:SEL 1

Selects an S-parameter correction data set.

CORR:SPD:STAT ON

Enables the S-parameter correction.

8.6.3.4 S-gamma corrections

Using the complex reflection coefficient, you can determine the power P delivered by the signal source with considerably greater accuracy.

The coefficient of the signal source Γ_{source} is defined by its magnitude and phase:

- [SENSe<Sensor>:]SGAMma:MAGNitude
- [SENSe<Sensor>:]SGAMma:PHASe

The complex reflection coefficient Γ_{sensor} of the sensor, which is also required for the correction, is prestored in the calibration data memory for many frequencies.

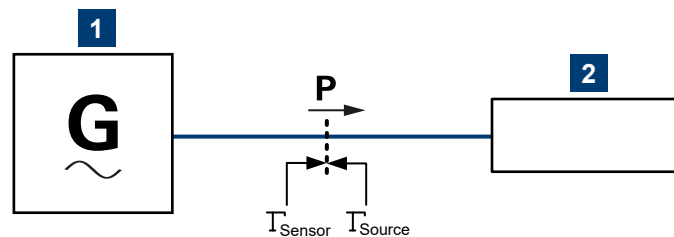

Figure 8-2: Correction of interactions between signal source and sensor

1 = Signal source

2 = Sensor

If the gamma correction is performed in combination with an S-parameter correction ([SENSe<Sensor>:]CORRection:SPDevice:STATe ON), the following is considered:

- Interaction of the signal source with the S-parameter device
- Input of the sensor, depending on the transmission, expressed by the term $s_{12}s_{21}$

The interaction between the complex reflection coefficient Γ_{sensor} of the sensor and the reflection of port 2 is expressed by s_{22} , see [Figure 8-3](#). If the S-parameter correction is enabled, this interaction is always considered, regardless whether gamma correction is performed or not.

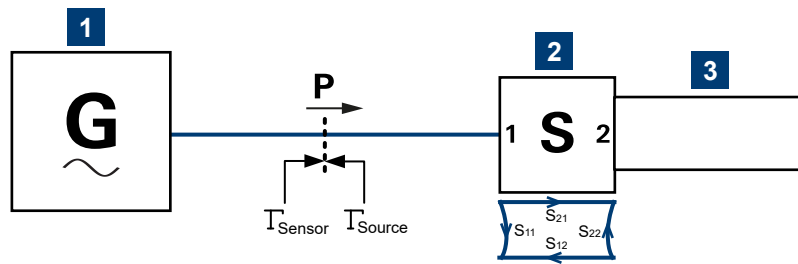

Figure 8-3: Correction of interactions between signal source, S-parameter device and sensor

1 = Signal source
 2 = S-parameter device
 3 = Sensor

Remote commands:

[SENSe<Sensor>:]SGAMma:CORRection:STATe.....91
 [SENSe<Sensor>:]SGAMma:MAGNitude..... 91
 [SENSe<Sensor>:]SGAMma:PHASe..... 91

[SENSe<Sensor>:]SGAMma:CORRection:STATe <state>

Enables or disables the use of the complex reflection coefficient to correct the interactions of sensor and signal source.

Suffix:

<Sensor> 1

Parameters:

<state> *RST: OFF

Manual operation: See "<State>" on page 46

[SENSe<Sensor>:]SGAMma:MAGNitude <magnitude>

Sets the magnitude of the complex reflection coefficient of the source, Γ_{source} .

Suffix:

<Sensor> 1

Parameters:

<magnitude> 0.0 \triangleq ideal matched source
 1.0 \triangleq total reflection
 Range: 0.0 to 1.0
 *RST: 0.0

Manual operation: See "Magnitude" on page 47

[SENSe<Sensor>:]SGAMma:PHASe <phase>

Sets the phase angle of the complex reflection coefficient of the source, Γ_{source} .

Suffix:

<Sensor> 1

Parameters:

<phase> Range: -360.0 degrees to 360.0 degrees
 *RST: 0.0 degrees
 Default unit: degrees

Manual operation: See "Phase" on page 47**8.6.3.5 I-gamma queries**

For the current frequency, queries the complex input reflection coefficient Γ_{in} of the following:

- Sensor if the S-parameter correction is disabled.
 ([SENSe<Sensor>:]SGAMma:CORRection:STATe OFF)
- S-parameter device if the S-parameter correction is enabled, S11 in [Figure 8-3](#).
 ([SENSe<Sensor>:]SGAMma:CORRection:STATe ON)

[SENSe<Sensor>:]IGAMma:MAGNitude?.....	92
[SENSe<Sensor>:]IGAMma:PHASe?.....	92
[SENSe<Sensor>:]IGAMma:EUNCertainty?.....	93

[SENSe<Sensor>:]IGAMma:MAGNitude?

Queries the magnitude of the complex input reflection coefficient Γ_{in} .

Suffix:

<Sensor> 1

Example:

IGAM:MAGN?
 Query
 1.739179E-02
 Response

Usage: Query only**[SENSe<Sensor>:]IGAMma:PHASe?**

Queries the phase angle of the complex input reflection coefficient Γ_{in} . The result is provided in degrees. Range: -180 degrees to +180 degrees.

Suffix:

<Sensor> 1

Example:

IGAM:PHAS?
 Query
 -1.327654E+02
 Response

Usage: Query only

[SENSe<Sensor>:]IGAMma:EUNCertainty?

Queries the expanded ($k = 2$) uncertainty of the magnitude of the complex input reflection coefficient Γ_{in} . Following gamma correction, the residual mismatch uncertainty becomes so small that it is practically negligible.

Suffix:

<Sensor> 1

Example:

```
IGAM:EUNC?
Query
5.000000E-03
Response
```

Usage: Query only

8.6.3.6 Using the S-Parameters program

The S-Parameters program helps loading an S-parameter table into the sensor. The S-Parameters program is part of the R&S NRP-Toolkit, see [Section 5.1, "R&S NRP-Toolkit"](#), on page 34.

To start the S-Parameters program

- ▶ In the Windows start menu, select "NRP Toolkit" > "S-Parameter Update Multi".

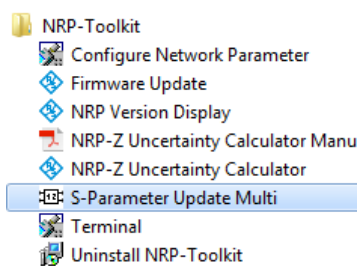

User interface of the S-Parameters program

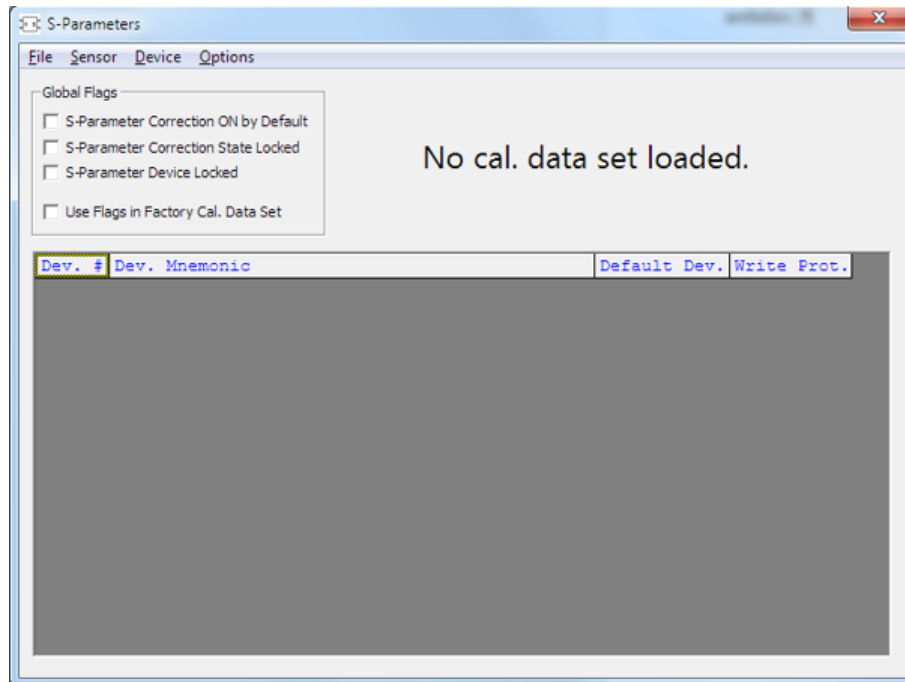

Figure 8-4: S-Parameters dialog

Menu bar.....	94
L File.....	94
L Sensor.....	95
L Device.....	95
L Options.....	95
L User Data.....	95
L Remote.....	95
L Show Cal. Data.....	95
Global Flags.....	96
L S-Parameter Correction ON by Default.....	96
L S-Parameter Correction State Locked.....	96
L S-Parameter Device Locked.....	96
L Use Flags in Factory Cal. Data Set.....	97
Device table.....	97

Menu bar

Contains the following submenus.

File ← Menu bar

Provides options for loading and saving calibration data files, see:

- "To change the S-parameter data" on page 99
- "To load an uncertainty parameter file" on page 100

Sensor ← Menu bar

Provides options for loading and saving calibration data directly from or to the sensor, see:

- ["To load a calibration data set from a sensor"](#) on page 97
- ["To save the calibration data on the sensor"](#) on page 101

Device ← Menu bar

Provides functions for editing the table of S-parameter devices.

Options ← Menu bar

Provides functions for editing user data, changing remote control timeouts, and displaying calibration data as plain text.

User Data ← Options ← Menu bar

Opens the "User Data" dialog.

Here, you can enter the name of the calibration laboratory and the calibration engineer that is stored in the calibration data set if changes are made.

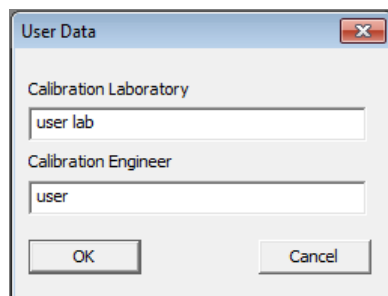
**Remote ← Options ← Menu bar**

Opens the "Remote Control Settings" dialog. It is normally not necessary to change timeouts.

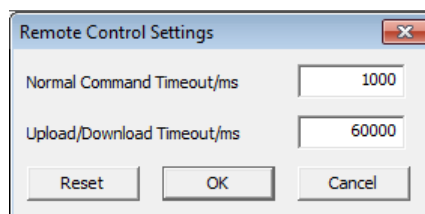
**Show Cal. Data ← Options ← Menu bar**

Displays the content of the calibration data set that has been loaded either from a file or directly from a sensor as a plain text.

You can copy the text output to the clipboard by clicking "Copy to Clipboard."

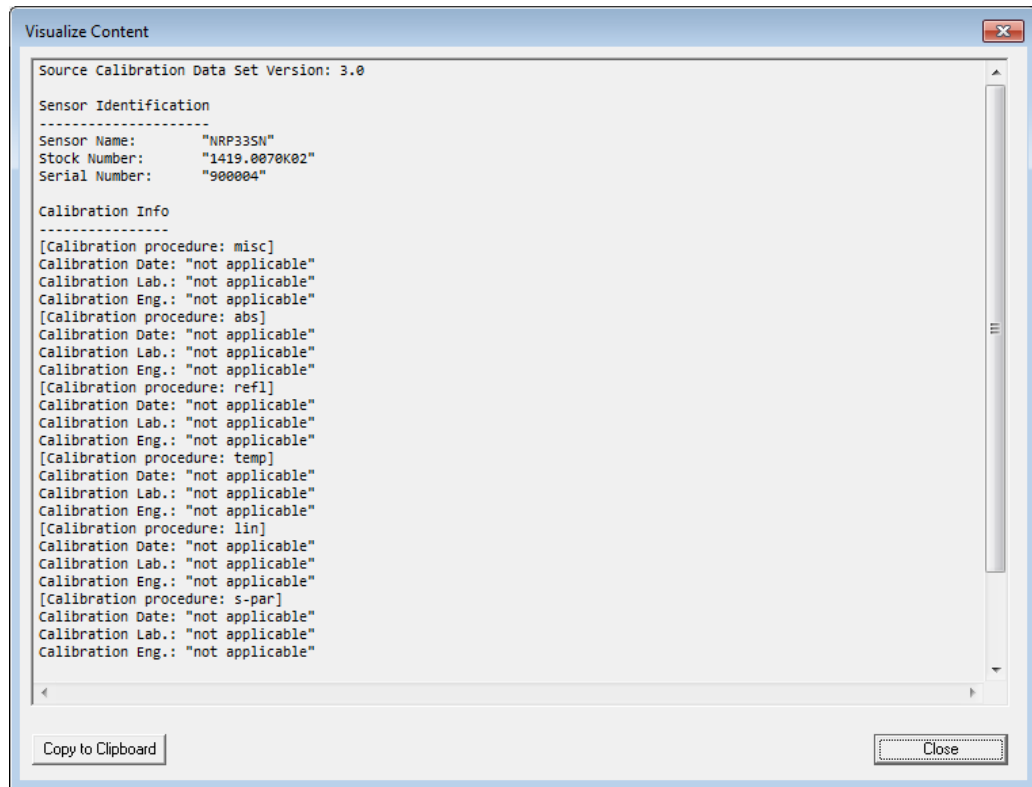

Figure 8-5: Example

Global Flags

Groups the settings for the sensor behavior regarding S-parameter corrections.

S-Parameter Correction ON by Default ← Global Flags

If this option is enabled, the S-parameter correction is activated automatically when the sensor is started.

S-Parameter Correction State Locked ← Global Flags

If enabled, the state that is selected with "S-Parameter Correction ON by Default" is locked and cannot be changed using:

- `[SENSe<Sensor>:]CORRection:SPDevice:STATe`
- Base unit

S-Parameter Device Locked ← Global Flags

If enabled, the S-parameter device that is selected as the default device in the table of S-parameter devices is locked and cannot be changed using:

- `[SENSe<Sensor>:]CORRection:SPDevice:SElect`
- Base unit

The default S-parameter device is the S-parameter device that you have selected when the sensor is started.

Use Flags in Factory Cal. Data Set ← Global Flags

Available if the sensor supports two different calibration data sets:

- Factory calibration data set containing all factory calibration data.
- User calibration data set that contains the S-parameter devices you have loaded.

Note: After you have added S-parameter devices and configured the global flags, disable this option. Otherwise, it is not possible to enable S-parameter correction because the flags in the factory calibration data set prevent it.

Device table

Shows a list of all S-parameter devices that are available in the calibration data set.

If you double-click an entry, a dialog for the device is opened that allows to import, export, and edit S-parameter data. See ["To change the S-parameter data"](#) on page 99.

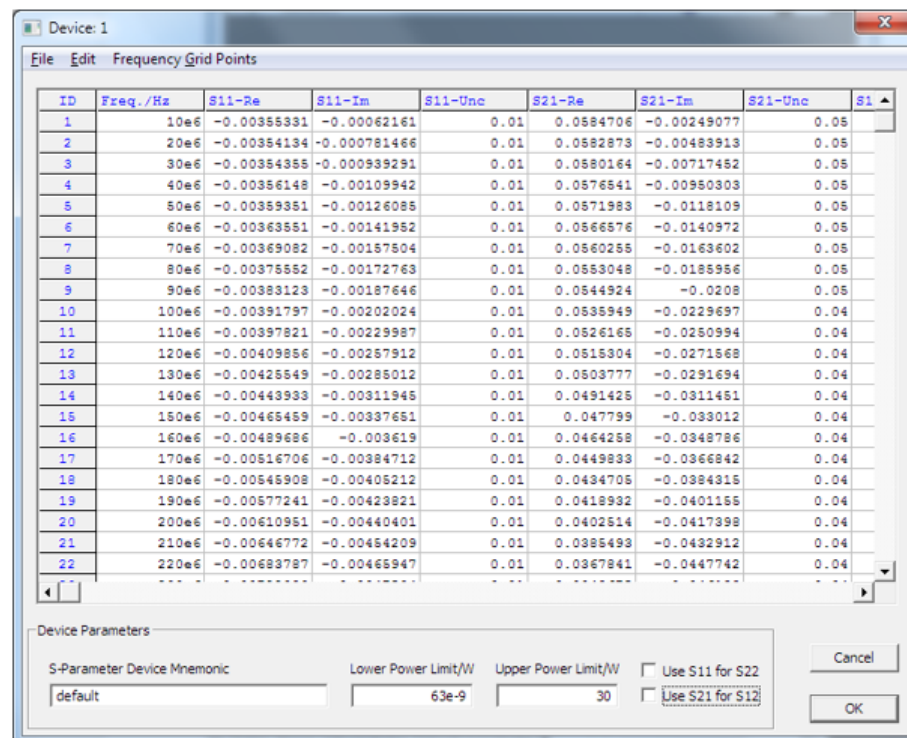

The screenshot shows a dialog box titled "Device: 1" with a menu bar (File, Edit, Frequency, Gnd Points) and a table of S-parameter devices. The table has columns for ID, Freq./Hz, S11-Re, S11-Im, S11-Unc, S21-Re, S21-Im, S21-Unc, and S1. Below the table are fields for "S-Parameter Device Mnemonic" (default), "Lower Power Limit/W" (63e-9), "Upper Power Limit/W" (30), and checkboxes for "Use S11 for S22" and "Use S21 for S12".

ID	Freq./Hz	S11-Re	S11-Im	S11-Unc	S21-Re	S21-Im	S21-Unc	S1
1	10e6	-0.00355331	-0.00062161	0.01	0.0584706	-0.00249077	0.05	
2	20e6	-0.00354134	-0.000781466	0.01	0.0582873	-0.00483913	0.05	
3	30e6	-0.00354355	-0.000939291	0.01	0.0580164	-0.00717452	0.05	
4	40e6	-0.00356148	-0.00109942	0.01	0.0576541	-0.00950303	0.05	
5	50e6	-0.00359351	-0.00126085	0.01	0.0571983	-0.0118109	0.05	
6	60e6	-0.00363551	-0.00141952	0.01	0.0566576	-0.0140972	0.05	
7	70e6	-0.00369082	-0.00157504	0.01	0.0560255	-0.0163602	0.05	
8	80e6	-0.00375552	-0.00172763	0.01	0.0553048	-0.0185956	0.05	
9	90e6	-0.00383123	-0.00187646	0.01	0.0544924	-0.0208	0.05	
10	100e6	-0.00391797	-0.00202024	0.01	0.0535949	-0.0229697	0.04	
11	110e6	-0.00397821	-0.00229987	0.01	0.0526165	-0.0250994	0.04	
12	120e6	-0.00409856	-0.00257912	0.01	0.0515304	-0.0271568	0.04	
13	130e6	-0.00425549	-0.00285012	0.01	0.0503777	-0.0291694	0.04	
14	140e6	-0.00443933	-0.00311945	0.01	0.0491425	-0.0311451	0.04	
15	150e6	-0.00465459	-0.00337651	0.01	0.047799	-0.033012	0.04	
16	160e6	-0.00489686	-0.003619	0.01	0.0464258	-0.0348786	0.04	
17	170e6	-0.00516706	-0.00384712	0.01	0.0449833	-0.0366842	0.04	
18	180e6	-0.00546908	-0.00405212	0.01	0.0434705	-0.0384315	0.04	
19	190e6	-0.00577241	-0.00423821	0.01	0.0418992	-0.0401155	0.04	
20	200e6	-0.00610951	-0.00440401	0.01	0.0402514	-0.0417399	0.04	
21	210e6	-0.00646772	-0.00454209	0.01	0.0385493	-0.0432912	0.04	
22	220e6	-0.00683787	-0.00465947	0.01	0.0367841	-0.0447742	0.04	

Performing configuration tasks

In this section, different configuration tasks performed with the sensor and the "S-Parameter Update Multi" tool are described.

To load a calibration data set from a sensor

Prerequisites: The sensor is connected to the computer and a connection is established.

1. Open the "S-Parameter Update Multi" program.
2. Select "Sensor" > "Load Calibration Data".

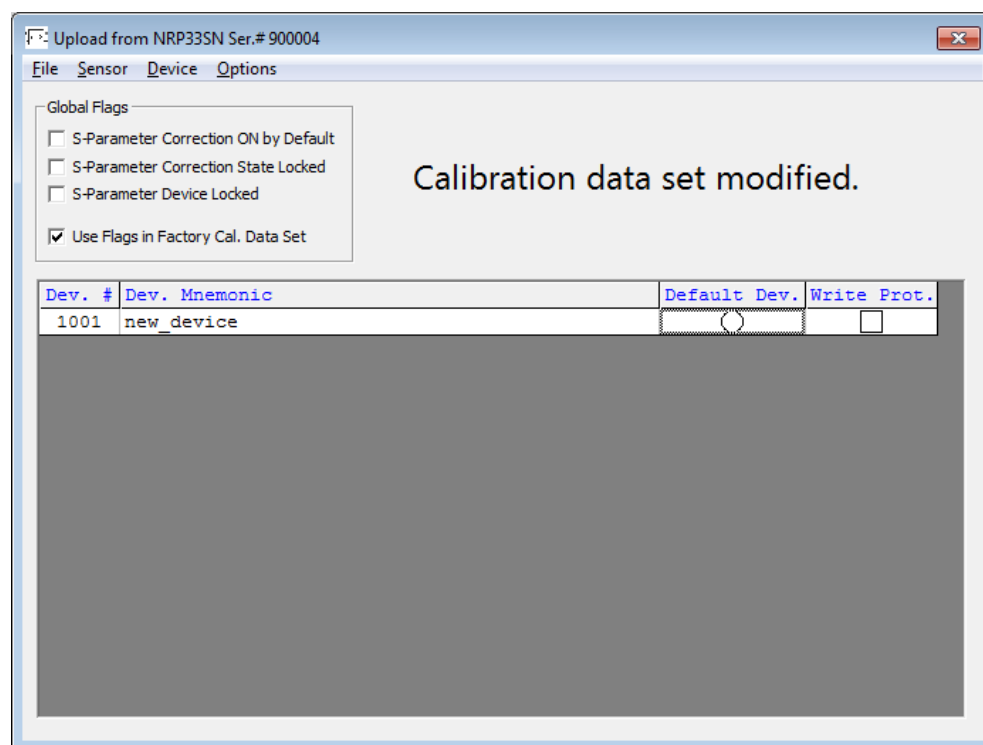

6. Create a backup of the calibration data set before making any changes.
Select "File" > "Save Calibration Data".
A dialog opens where you can select the location to save the calibration data.

To change the S-parameter data

1. In the device table, double-click an entry. See also "[Device table](#)" on page 97.
2. Select "File" > "Import S2P".
3. Select the *.S2P file that you want to import.
4. Confirm with "Open".
The data from the selected file is loaded in the device table.
All uncertainties are set to zero.

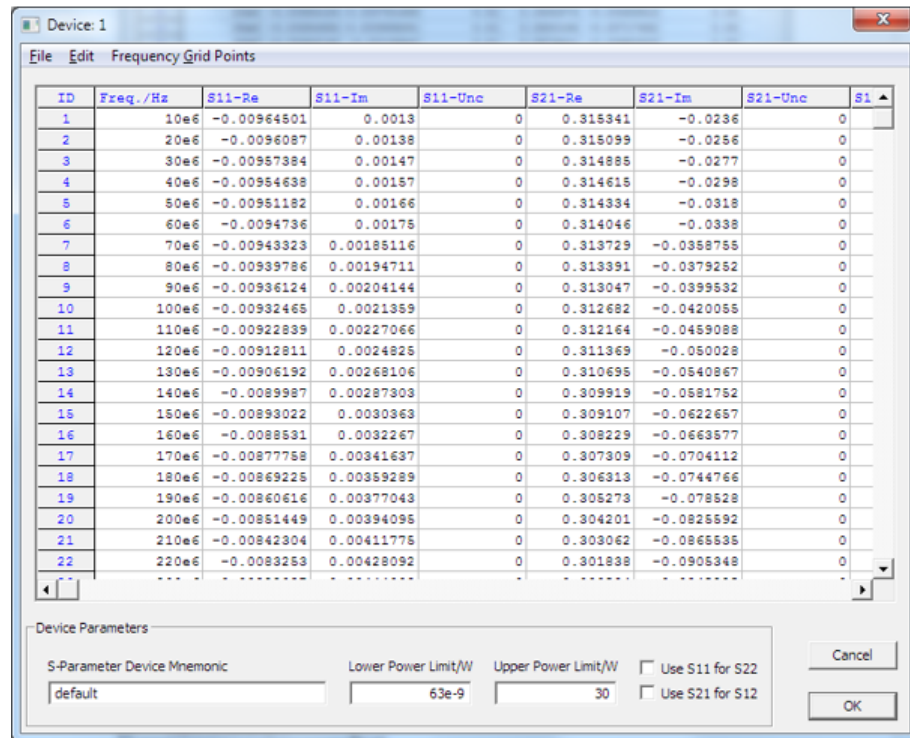

- If needed, load uncertainty data. See ["To load an uncertainty parameter file"](#) on page 100.
- Check the entries in the "S-Parameter Device Mnemonic", "Lower Power Limit/W" and "Upper Power Limit/W" fields
- If necessary, change the entries.
For example, the lower and upper power limits are deduced from the power limits of the sensor itself and the minimum attenuation of the S-parameter device. If the "Upper Power Limit/W" entry is higher than the power dissipation rating of the attenuator, reduce it accordingly.
- Click "OK" to apply the changes.
If you want to discard the change, click "Cancel".

To load an uncertainty parameter file

- In the device table, double-click an entry. See also ["Device table"](#) on page 97.
- Select "File" > "Import uncertainties".
- Select the file that you want to import.
- Confirm with "Open".

The data from the selected file is loaded in the device table.

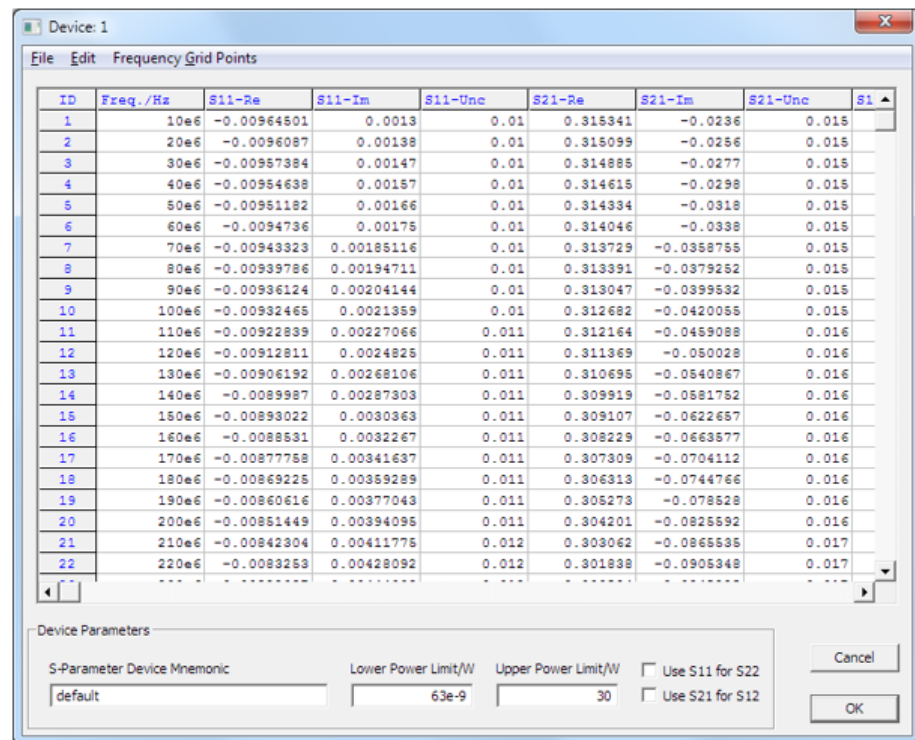

To save the calibration data on the sensor

1. Select "Sensor" > "Save Calibration Data".

The "Download Calibration Data" dialog opens.

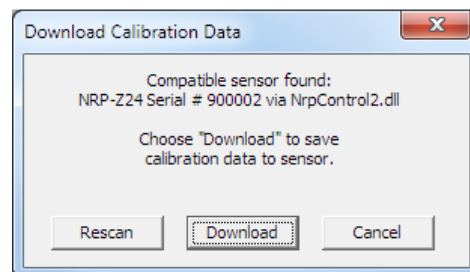

2. Confirm that the correct sensor is selected by clicking "Download".

After a successful transfer of the data to the sensor, a confirmation message is displayed.

The sensor can be used with the new S-parameter data.

S2P measurement data files

S2P files are human-readable text files that contain header information and the complex S-parameters of the device under test in columns. This section briefly describes the format of the S2P file.

An S2P measurement data file has the following structure (square brackets indicate that the enclosed content is optional):

- **Option line**

The option line has the format $\#[<frequency\ unit>][<parameter>][<format>][<R\ n>]$, where:

- #
Identifies the option line.
- $<frequency\ unit>$
Possible values are Hz, kHz, MHz or GHz. If a frequency unit is not specified, GHz is implicitly assumed.
- $<parameter>$
For S-parameter files. If no parameter is specified, S is implicitly assumed.
- $<format>$
Possible values are MA (linear magnitude and phase in degree), DB (magnitude in dB, phase in degree) or RI (real and imaginary part). If a format is not specified, MA is implicitly assumed.
- $<R\ n>$
R is optional and followed by the reference impedance in Ω . If no entry is made, R50 is implicitly assumed.

The option line therefore reads:

$\# [HZ | KHZ | MHZ | GHZ] [S] [MA | DB | RI] [R\ 50]$.

- **Measurement frequencies**

The measurement frequencies are listed in ascending order and are specified as follows:

$f_i\ s_{11}(f_i)\ s_{21}(f_i)\ s_{12}(f_i)\ s_{22}(f_i)$

Where f_i is the i-th frequency and $s_{jk}(f_i)$ is the display format as specified in the option line:

- $|s_{jk}(f_i)|arg\ s_{jk}(f_i)$
Display format for linear magnitude and phase in degree (MA)
- $20.lg|s_{jk}(f_i)|\ arg\ s_{jk}(f_i)$
Display format for magnitude in dB and phase in degree (DB)
- $Re|s_{jk}(f_i)|Im|s_{jk}(f_i)|$
Display format for real and imaginary part (RI)

- **Comments**

Any line starting with an exclamation mark (!) is interpreted as a comment line.

Uncertainty data files

An uncertainty data file has the following structure (square brackets indicate that the enclosed content is optional):

- **Option line**

The option line has the format $\#[<frequency\ unit>]<parameter>[<format>][<R\ n>]$, where:

- #
Identifies the option line.
- $<frequency\ unit>$
Possible values are Hz, kHz, MHz or GHz. If a frequency unit is not specified, GHz is implicitly assumed.

- *<parameter>*
U must be specified for uncertainty data files. If a parameter is not specified, S is implicitly assumed and as a result an error message is triggered.
- *<format>*
This value is ignored in uncertainty measurement files. The entry is therefore irrelevant.
- *<R n>*
R is optional and followed by the reference impedance in Ω . If no entry is made, R50 is implicitly assumed.

The option line therefore reads:

```
# [HZ | KHZ | MHZ | GHZ] U [MA | DB | RI] [R 50].
```

- **Measurement frequencies**

The measurement frequencies are listed in ascending order and are specified as follows:

```
 $f_i$  unc[s11( $f_i$ )] unc[s21( $f_i$ )] unc[s12( $f_i$ )] unc[s22( $f_i$ )]
```

Where f_i is the i-th frequency and $unc[s_{jk}(f_i)]$ is the uncertainty of the S-parameters that is forwarded as follows:

- As extended absolute uncertainty ($k = 2$) for the magnitude of reflection parameters s_{11} and s_{22}
- As extended uncertainties ($k = 2$) in dB for the magnitude of transmission parameters s_{21} and s_{12}

- **Comments**

Any line starting with an exclamation mark (!) is interpreted as a comment line.

8.7 Configuring measurement results

See also:

- [Section 8.8, "Querying measurement results"](#), on page 105
- [Setting the power unit](#)..... 103
- [Setting the result format](#)..... 104

8.7.1 Setting the power unit

The UNIT subsystem contains commands for setting up the power unit.

UNIT:POWer <unit>

Sets the output unit for the measured power values.

Parameters:

```
<unit>          DBM | W | DBUV
                 *RST:      W
```

Example: UNIT:POW DBM

8.7.2 Setting the result format

The `FORMat` subsystem sets the format of numeric data (measured values) that is exchanged between the remote control computer and the sensors if high-level measurement commands are used.

Remote commands:

<code>FORMat:BORDER</code>	104
<code>FORMat[:DATA]</code>	104
<code>FORMat:SREGister</code>	105

`FORMat:BORDER` <border>

Selects the order of bytes in 32-bit or 64-bit binary data.

Parameters:

<border> `NORMAL` | `SWAPped`

NORMAL

The 1st byte is the least significant byte, the 4th/8th byte the most significant byte.

Fulfills the Little Endian (little end comes first) convention, used by x86/x64 CPUs, for example.

SWAPped

The 1st byte is the most significant byte, the 4th/8th byte the least significant byte.

Fulfills the Big Endian (big end comes first) convention.

*RST: `NORMAL`

Example: `FORM:BORD NORM`

`FORMat[:DATA]` [<data,length>, <length>]

Specifies how the sensor sends the numeric data to the controlling host/computer.

Parameters:

<data,length> <`REAL,32` | `64`>

REAL

Block of binary values, 32-bit or 64-bit each; also called "SCPI definite length block"

32 | 64

32-bit or 64-bit

If you omit the length, the sensor sets the last used length.

Example for `REAL, 32` format:

#6768000....<binary float values>....

Example for `REAL, 64` format:

#71536000....<binary float values>....

<data[,length]> <`ASCIi`[,0 to 12]>

ASCIi

List of comma-separated, readable values.

[,0 to 12]

Defines the number of decimal places.

The reset value 0 does not restrict the number of decimal places.

Example for ASCii, 4 format:

1.2938e-06, -4.7269e-11, ...

*RST: ASCii,0

FORMat:SREGister <sregister>

Specifies which format is used for the return value of *STB?.

Parameters:

<sregister> ASCii | HEXadecimal | OCTal | BINary

*RST: ASCii

Example:

FORM:SREG ASC

8.8 Querying measurement results

After the measurement, you can query the measurement results.

8.8.1 Continuous average measurement results

Commands for querying the continuous average measurement results and configuring the result buffer.

FETCh<Sensor>:ARRay[:POWer][:AVG]?.....	105
FETCh<Sensor>[:SCALar][:POWer][:AVG]?.....	106
[SENSe<Sensor>][:POWer][:AVG:]BUFFer:CLEar.....	106
[SENSe<Sensor>][:POWer][:AVG:]BUFFer:COUNT?.....	106
[SENSe<Sensor>][:POWer][:AVG:]BUFFer:DATA?.....	106
[SENSe<Sensor>][:POWer][:AVG:]BUFFer:SIZE.....	106
[SENSe<Sensor>][:POWer][:AVG:]BUFFer:STATE.....	107

FETCh<Sensor>:ARRay[:POWer][:AVG]?

Queries the last valid measurement result of a buffered continuous average measurement.

Suffix:

<Sensor> 1

Usage:

Query only

FETCh<Sensor>[:SCALar][:POWer][:AVG]?

Queries the last valid measurement result of the measurand that was configured before.

Suffix:

<Sensor> 1

Usage: Query only

[SENSe<Sensor>:][POWer:][AVG:]BUFFer:CLEar

Clears the contents of the result buffer.

Suffix:

<Sensor> 1

Example: BUFF:CLE

Usage: Event

[SENSe<Sensor>:][POWer:][AVG:]BUFFer:COUNT?

Queries the number of results that are currently stored in the result buffer.

Suffix:

<Sensor> 1

Example: BUFF:COUNT?

Usage: Query only

[SENSe<Sensor>:][POWer:][AVG:]BUFFer:DATA?

Queries the results of the continuous average result buffer and returns them even if the buffer is not full.

In contrast, `FETCh<Sensor>[:SCALar][:POWer][:AVG]?` returns a result only if the buffer is full.

Suffix:

<Sensor> 1

Usage: Query only

[SENSe<Sensor>:][POWer:][AVG:]BUFFer:SIZE <count>

Sets the size of the result buffer.

You can enable the buffer using `[SENSe<Sensor>:][POWer:][AVG:]BUFFer:STATE`.

Suffix:

<Sensor> 1

Parameters:

<count> Range: 1 to 8192
 *RST: 1

Example:

BUFF:SIZE 1

See [Section 9.2, "Performing a buffered continuous average measurement"](#), on page 129.

[SENSe<Sensor>:][POWer:][AVG:]BUFFer:STATe <state>

Enables or disables a buffered continuous average measurement. If enabled, the sensor collects all results generated by trigger events until the buffer is filled.

You can set the size of the buffer using [\[SENSe<Sensor>:\] \[POWer:\] \[AVG:\]BUFFer:SIZE](#).

Suffix:

<Sensor> 1

Parameters:

<state> ON | OFF
 *RST: OFF

Example:

BUFF:STAT OFF

8.9 Calibrating, zeroing

Zeroing removes offset voltages from the analog circuitry of the sensor, so that there are only low powers displayed if no power applied. The zeroing process can take more than 8 s to complete.

Zeroing is recommended if:

- The temperature has varied by more than 5 K.
- The sensor has been replaced.
- No zeroing was performed in the last 24 hours.
- Signals of very low power are to be measured, for instance, if the expected measured value is less than 10 dB above the lower measurement range limit.



Turn off all test signals before zeroing. An active test signal during zeroing causes an error.

Remote commands:

CALibration:DATA	108
CALibration:DATA:LENGth?	108
CALibration:TEST?	108
CALibration:TEST:DEVIation?	108
CALibration:TEST:REFerence?	109

CALibration:USER:DATA.....	109
CALibration:USER:DATA:LENGth?.....	109
CALibration<Channel>:ZERO:AUTO.....	109

CALibration:DATA <caldata>

Writes a binary calibration data set in the memory of the sensor.

Parameters:

<caldata>	<block_data>
	Block of binary calibration data, structured in a so-called "SCPI definite length block".

CALibration:DATA:LENGth?

Queries the length in bytes of the calibration data set currently stored in the flash memory. Programs that read out the calibration data set can use this information to determine the capacity of the buffer memory required.

Example:	CAL:DATA:LENG?
	Query
	57392
	Response

Usage:	Query only
---------------	------------

CALibration:TEST?

The thermal sensors are equipped with an additional test heater.

Queries the power difference when measuring with the test heater enabled and disabled. Unit: W.

Usage:	Query only
---------------	------------

CALibration:TEST:DEVIation?

The thermal sensors are equipped with an additional test heater.

Queries the relative deviation of the current power difference from the reference value stored in the calibration data set. The relative deviation is calculated as follows:

$$\langle \text{relative deviation} \rangle = (\langle \text{current power difference} \rangle / \langle \text{reference value} \rangle) - 1$$

with

<current power difference>: CALibration:TEST?

<reference value>: CALibration:TEST:REference?

Usage:	Query only
---------------	------------

CALibration:TEST:REFeRence?

The thermal sensors are equipped with an additional test heater.

Queries the reference value of the power difference when measuring with the external heater enabled and disabled. The reference value is determined during the calibration process and stored in the calibration data set. Unit: W.

Usage: Query only

CALibration:USER:DATA <caldata>

Transfers the user calibration data set, which mainly contains S-parameter sets for user-specific devices. The query returns the data as it was downloaded to the sensor before.

After downloading of a new user calibration data set to the sensor, the current S-parameter correction settings become invalid. Safe operation of the sensor is only possible if the `SELEct` and `STATe` commands are repeated after download. See also:

- `[SENSe<Sensor>:]CORRection:SPDevice:STATe`
- `[SENSe<Sensor>:]CORRection:SPDevice:SELEct`

Parameters:

<caldata> <block_data>

CALibration:USER:DATA:LENGth?

Queries the length of the user calibration data block.

Usage: Query only

CALibration<Channel>:ZERO:AUTO <state>

Performs zero calibration.

Turn off all test signals before zeroing. An active test signal during zeroing causes an error.

While zero calibration is in progress, no queries or other setting commands are allowed, since the command is synchronous. Any communication attempt can run into a timeout.

After zero calibration, query the static error queue (`SYSTem:SERRor?`). The following responses are possible:

- 0
No error, the zero calibration was successful.
- -240
Warning, zero calibration failed.

Suffix:	
<Channel>	1 to 4 Measurement channel if more than one channel is available.
Parameters:	
<state>	ONCE Only valid parameter for this command. OFF Return value if no calibration is in progress.
Example:	*CLS CAL1:ZERO:AUTO ONCE Performs zeroing. Takes several seconds.
Manual operation:	See " Zero Calibration " on page 47

8.10 Running a self-test

The self-test allows a test of the internal circuitry of the sensor.



Do not apply a signal to the sensor while the self-test is running. If the self-test is carried out with a signal being present, error messages can erroneously be output for the following test steps:

- Offset Voltages
- Noise Voltage

TEST:SENSOr? [<Item>]

Starts a self-test of the sensor.

In contrast to *TST?, this command returns detailed information that you can use for troubleshooting. If one test step or a part of it fails, the overall result is FAIL.

For result examples and interpretation of the results, see [Section 12.3, "Performing a self-test"](#), on page 153.

Query parameters:

<Item> String

Usage: Query only

Manual operation: See "[Selftest](#)" on page 51

8.11 Configuring the system

The SYSTem subsystem contains a series of commands for general functions that do not directly affect the measurement.

8.11.1 Preset and initialize

SYSTem:PRESet	111
SYSTem:INITialize	111

SYSTem:PRESet

Resets the sensor.

The command essentially corresponds to the *RST command, with the exception that the settings of the following commands are persistently held:

- [INITiate:CONTinuous](#)
- [\[SENSe<Sensor>:\]AVERage:TCONtrol](#)

Usage: Event

SYSTem:INITialize

Sets the sensor to the standard state.

The sensor loads the default settings for all test parameters in the same way as when using *RST. The sensor outputs a complete list of all supported commands and parameters. The remote control software can automatically adapt to the features of different types of sensors with different functionality.

Usage: Event

8.11.2 Reboot and restart

SYSTem:REBoot	111
SYSTem:REStart	111

SYSTem:REBoot

Reboots the sensor.

Usage: Event

Manual operation: See "[Reboot](#)" on page 53

SYSTem:REStart

Restarts the firmware of the sensor.

Usage: Event

8.11.3 Firmware update

See also [Section 7, "Firmware update"](#), on page 54.

SYSTem:FWUPdate <fwudata>

Loads new operating firmware into the sensor. Rohde & Schwarz provides the update file. For further details, see [Section 7, "Firmware update"](#), on page 54.

If you want to integrate a firmware update function in an application, see the example given in [Section 7.2.4, "Using remote control"](#), on page 58.

Setting parameters:

<fwudata>	<block_data> Definite length arbitrary block data containing the direct copy of the binary *.rsu file in the following format: # Single digit indicating how many digits follow to specify the size of the binary file. Number that specifies the size of the binary file. Binary data 0x0a as appended delimiter (single '\n' character) for line feed
------------------------	--

Usage: Setting only

Manual operation: See ["Firmware Update"](#) on page 52

SYSTem:FWUPdate:STATus?

Reads the result of the firmware update performed using [SYSTem:FWUPdate](#) on page 112.

While a firmware update is in progress, the LED of the sensor flashes in bright white color. When the firmware update is completed, you can read the result.

The result of the query is a readable string.

Example:	SYST:FWUP:STAT? Query "Success" Response
-----------------	---

Usage: Query only

Manual operation: See ["Firmware Update"](#) on page 52

8.11.4 Password management

We recommend that you change the preconfigured instrument password before connecting the sensor to a network.

SYSTem:SECurity:PASSword:SECurity	113
SYSTem:SECurity:PASSword:USER	113

SYSTem:SECurity:PASSword:SECurity <passwd1>, <passwd2>

For future use.

Setting parameters:

<passwd1>

<passwd2>

Usage: Setting only

SYSTem:SECurity:PASSword:USER <passwd1>, <passwd2>

Sets a new user password, also called instrument password. You need this password to access the LAN sensors by SCP or SFTP. See also [Section 7.2.3, "Using SCP or SFTP"](#), on page 57.

The preconfigured user name and instrument password are *instrument*.

The command is restricted to remote control over the USB interface (USBTMC).

Setting parameters:

<passwd1> Old user password, entered as a string.

<passwd2> New user password, entered as a string.

Example: SYST:SEC:PASS:USER "instrument",
"rohdeandschwarz"

Usage: Setting only

8.11.5 Network settings

Requires a sensor with networking capabilities, a LAN sensor.

SYSTem:COMMunicate:NETWork[:COMMOn]:DOMain	113
SYSTem:COMMunicate:NETWork[:COMMOn]:HOSTname	114
SYSTem:COMMunicate:NETWork:CONFigure	114
SYSTem:COMMunicate:NETWork:IPADdress	115
SYSTem:COMMunicate:NETWork:IPADdress:GATeway	115
SYSTem:COMMunicate:NETWork:IPADdress:INFO?	115
SYSTem:COMMunicate:NETWork:IPADdress:MODE	115
SYSTem:COMMunicate:NETWork:IPADdress:SUBNet:MASK	116
SYSTem:COMMunicate:NETWork:RESet	116
SYSTem:COMMunicate:NETWork:REStart	116
SYSTem:COMMunicate:NETWork:STATus?	116

SYSTem:COMMunicate:NETWork[:COMMOn]:DOMain <domain>

Requires a sensor with networking capabilities, a LAN sensor.

Sets the domain of the network.

Parameters:

<domain>

Example:

```
SYST:COMM:NETW:COMM:DOM 'ABC.DE'
```

Sets *ABC.DE* as domain of the network.

SYSTem:COMMunicate:NETWork[:COMMon]:HOSTname <hostname>

Requires a sensor with networking capabilities, a LAN sensor.

Sets the individual host name of the sensor.

In a LAN that uses a DNS server (domain name system server), you can access each connected sensor using a unique host name instead of its IP address. The DNS server translates the host name to the IP address. Using a host name is especially useful if a DHCP server is used, as a new IP address can be assigned each time the sensor is restarted.

The sensor performs the change of the host name immediately after the command is sent. For this purpose, the sensor restarts its connection to the network, which can take several seconds. During this time, you cannot address the sensor. After the restart, you can only address the sensor using the newly set host name.

Note: We recommend that you do not change the default host name to avoid problems with the network connection. However, if you change the host name, be sure to use a unique name.

Parameters:

<hostname>

Example:

```
SYST:COMM:NETW:COMM:HOST
'powersensor-2nd-floor'
```

Sets *powersensor-2nd-floor* as new host name.

SYSTem:COMMunicate:NETWork:CONFigure <value>

Requires a sensor with networking capabilities, a LAN sensor.

Sets a static address. Combines the three commands to set the IP address, the subnet mask and the gateway.

Setting parameters:

<value>

```
"<mode>,<IP address>,<subnet mask>,<gateway>"
```

The string has to start with <mode> = STAT. Otherwise, it is ignored.

<IP address> see [SYSTem:COMMunicate:NETWork:IPADdress](#) on page 115.

<subnet mask> see [SYSTem:COMMunicate:NETWork:IPADdress:SUBNet:MASK](#) on page 116.

<gateway> see [SYSTem:COMMunicate:NETWork:IPADdress:GATeway](#) on page 115.

Example:

```
SYST:COMM:NETW:CONF 'STAT,
147.161.235.79,255.255.255.0,192.168.1.200'
```

Usage: Setting only

SYSTem:COMMunicate:NETWork:IPADdress <ipaddress>

Requires a sensor with networking capabilities, a LAN sensor.

Effective only if `SYSTem:COMMunicate:NETWork:IPADdress:MODE` is set to `STATic`.

Sets the IP address of the sensor.

Parameters:

<ipaddress>

Example: `SYST:COMM:NETW:IPAD '147.161.235.79'`
Sets `147.161.235.79` as IP address.

Manual operation: See "[IP Address](#)" on page 50

SYSTem:COMMunicate:NETWork:IPADdress:GATeway <gateway>

Requires a sensor with networking capabilities, a LAN sensor.

Effective only if `SYSTem:COMMunicate:NETWork:IPADdress:MODE` is set to `STATic`.

Sets the IP address of the default gateway.

Parameters:

<gateway>

Example: `SYST:COMM:NETW:IPAD:GAT '192.168.1.200'`
Sets `192.168.1.200` as IP address of the default gateway.

Manual operation: See "[Gateway](#)" on page 51

SYSTem:COMMunicate:NETWork:IPADdress:INFO?

Requires a sensor with networking capabilities, a LAN sensor.

Queries the network status information.

Usage: Query only

SYSTem:COMMunicate:NETWork:IPADdress:MODE <mode>

Requires a sensor with networking capabilities, a LAN sensor.

Sets how the IP address is assigned.

Parameters:

<mode> AUTO | STATic

AUTO

Assigns the IP address automatically, provided the network supports DHCP.

STATic

Enables assigning the IP address manually.

*RST: AUTO

Example:

SYST:COMM:NETW:IPAD:MODE AUTO

The IP address is assigned automatically.

Manual operation: See "[DHCP](#)" on page 51

SYSTem:COMMunicate:NETWork:IPADdress:SUBNet:MASK <netmask>

Requires a sensor with networking capabilities, a LAN sensor.

Effective only if `SYSTem:COMMunicate:NETWork:IPADdress:MODE` is set to `STATic`.

Sets the subnet mask.

Parameters:

<netmask> The subnet mask consists of four number blocks separated by dots. Every block contains 3 numbers in maximum.

Example:

SYST:COMM:NETW:IPAD:SUBN:MASK '255.255.255.0'

Sets `255.255.255.0` as subnet mask.

Manual operation: See "[Subnet Mask](#)" on page 50

SYSTem:COMMunicate:NETWork:RESet

Requires a sensor with networking capabilities, a LAN sensor.

Resets the LAN network settings to the default values.

Usage: Event

SYSTem:COMMunicate:NETWork:REStart

Requires a sensor with networking capabilities, a LAN sensor.

Restarts the network connection to the DUT that means terminates the connection and sets it up again.

Example:

SYST:COMM:NETW:REST

Usage: Event

SYSTem:COMMunicate:NETWork:STATus?

Requires a sensor with networking capabilities, a LAN sensor.

Queries the network configuration state.

Example: `SYST:COMM:NETW:STAT?`
 Query
 UP
 Response: The network is active.

Usage: Query only

8.11.6 Remote settings

<code>SYSTem:HELP:HEADers?</code>	117
<code>SYSTem:HELP:SYNTax?</code>	117
<code>SYSTem:HELP:SYNTax:ALL?</code>	117
<code>SYSTem:LANGUage</code>	117
<code>SYSTem:PARAmeters?</code>	118
<code>SYSTem:PARAmeters:DELTA?</code>	118
<code>SYSTem:TRANsaction:BEgin</code>	118
<code>SYSTem:TRANsaction:END</code>	118
<code>SYSTem:VERSion?</code>	118

SYSTem:HELP:HEADers? [<Item>]

Returns a list of all SCPI commands supported by the sensor.

Query parameters:

<Item> <block_data>

Usage: Query only

SYSTem:HELP:SYNTax? [<Item>]

Queries the relevant parameter information for the specified SCPI command.

Query parameters:

<Item>

Example: `SYST:HELP:SYNT? 'sens:aver:coun'`

Usage: Query only

SYSTem:HELP:SYNTax:ALL?

Queries the implemented SCPI commands and their parameters. Returns the result as a block data.

Usage: Query only

SYSTem:LANGUage <language>

Selects an emulation of a different command set.

Parameters:

<language> SCPI
*RST: SCPI

SYSTem:PARAmeters?

Returns an XML-output containing all commands with the following information, if available for the command:

- Default value
- Minimum value
- Maximum value
- Parameters
- Limits

Each command is shortened to a command token, consisting only of the mnemonics short form. For example, CALibration:DATA is shortened to CALDATA as command token.

Usage: Query only

SYSTem:PARAmeters:DELTA?

Returns an XML-output containing all commands that differ from the defined default status set by *RST on page 63.

The commands are accompanied by the same information as for [SYSTem:PARAmeters?](#).

Usage: Query only

SYSTem:TRANSACTION:BEGIN

Starts a series of settings.

Usage: Event

SYSTem:TRANSACTION:END

Ends a series of settings.

Usage: Event

SYSTem:VERSION?

Queries the SCPI version that the command set of the sensor complies with.

Example: `SYST:VERS?`
 Query
 1999.0
 Response: SCPI version from 1999.

Usage: Query only

8.11.7 Sensor information

Device footprint

The device footprint contains information about the sensor hardware, the installed software, and license data.

<code>SYSTem:DFPRint<Channel>?</code>	119
<code>SYSTem:DFPRint:HISTory:COUNT?</code>	119
<code>SYSTem:DFPRint:HISTory:ENTRy?</code>	119
<code>SYSTem:INFO?</code>	120
<code>SYSTem:INFO:SUPPort?</code>	120
<code>SYSTem[:SENSor]:NAME</code>	120

`SYSTem:DFPRint<Channel>?`

Queries the current device footprint.

Suffix:

<Channel> 1...4
 Measurement channel if more than one channel is available.

Usage: Query only

`SYSTem:DFPRint:HISTory:COUNT?`

Queries the number of device footprints in the history.

Return values:

<Count>

Usage: Query only

`SYSTem:DFPRint:HISTory:ENTRy? <index>`

Queries a device footprint from the history.

Query parameters:

<index> **0**
 Most recent device footprint

Return values:

<XmlDeviceFootprint><dblock>

Usage: Query only

SYSTem:INFO? [<item>]

Queries information about the sensor.

If queried without parameters, the command returns all available information in the form of a list of strings separated by commas.

If you want to query specific information, add the query parameter:

```
SYST:INFO? "<string>"
```

Query parameters:

<item> "Manufacturer", "Type", "Stock Number", "Serial", "SW Build", "Sensor Name", "Hostname", "IP Address", "Technology", "Function", "MinPower", "MaxPower", "MinFreq", "MaxFreq", "Resolution", "Impedance", "Coupling", "Cal. Due Date", "Cal. Abs.", "Cal. Refl.", "Cal. S-Para.", "Cal. S-Para. (User)", "Cal. Misc.", "Cal. Temp.", "Cal. Lin.", "SPD Mnemonic", "TestLimit", "TestLimit pd", "Uptime"
"Host name" and "IP Address" are available only for LAN sensors.

Usage: Query only

Manual operation: See "[Sensor Information](#)" on page 47

SYSTem:INFO:SUPPort?

Queries the diagnostic and troubleshooting data. Returns the results as a definite length-arbitrary block data containing a compressed archive (.tar.gz) of the diagnostic and troubleshooting data in the following format:

- #
- Single digit indicating how many digits follow to specify the size of the compressed archive.
- Number that specifies the size of the compressed archive.
- Compressed archive data
- 0x0a as appended delimiter (single '\n' character) for line feed

See also [Section 12.6, "Collecting information for technical support"](#), on page 156.

Usage: Query only

SYSTem[:SENSor]:NAME <sensorname>

Sets the name of the sensor according to your requirements.

The specified name is displayed in the web user interface of the network sensors.

The name that you specify here is independent from the host name of the sensor. However, if you do not specify a name, the host name is used as default.

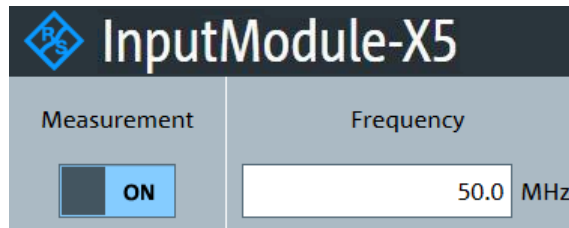

Figure 8-6: Sensor name displayed in the web user interface

Parameters:

<sensorname>

Example: SYST:NAME "InputModule-X5"

Manual operation: See "[Sensor Name](#)" on page 51

8.11.8 Status display and update

See also [Section 4.2, "Status information"](#), on page 31.

SYSTem:LED:COLor	121
SYSTem:LED:MODE	122
SYSTem:RUTime	122
SYSTem:SUTime	122

SYSTem:LED:COLor <color>

Effective if the status LED is user-controlled, see [SYSTem:LED:MODE USER](#).

Sets the color and the flash code of the status LED.

Parameters:

<color> Hexadecimal code: #H0<emitting type><color>
 With
 <emitting type>: 0 = steady on; 1 = slowly flashing; 2 = fast flashing
 <color>: FF0000 = red, 00FF00 = green, 0000FF = blue
 Range: 0 to #H0FFFFFFF
 *RST: #H00A0A0A0

Example:

```
SYST:LED:MODE USER
The status LED is user-controlled.
```

```
SYST:LED:COL #H01FF0000
The LED flashes slowly in red.
```

```
SYST:LED:MODE SENS
The status LED is controlled by the sensor firmware.
```

SYSTem:LED:MODE <mode>

Sets whether the color and flash code of the status LED are controlled by the sensor firmware or by the user settings.

For more information, see [SYSTem:LED:COLor](#).

Parameters:

<mode> USER | SENSor
*RST: SENSor

SYSTem:RUTime <update_time>

Effective only in the NRP legacy mode. Relevant only in continuous measurement mode, [INITiate:CONTinuous](#) ON.

Sets the result update time. The result update time is the maximum rate in which the sensor can output measurement results.

Parameters:

<update_time> Range: 0.0 s to 10.0 s
*RST: 0.1 s
Default unit: s

SYSTem:SUTime <update_time>

Effective only in the NRP legacy mode. Relevant only in continuous measurement mode, [INITiate:CONTinuous](#) ON.

Sets the status update time. The status update time is the maximum rate in which the sensor can output measurement results.

Parameters:

<update_time> Range: 0.0 s to 10.0 s
*RST: 10e-3 s
Default unit: s

8.11.9 Measurement limits and levels

SYSTem:MINPower?	122
SYSTem:MINPower:UNIT	123
SYSTem:TLEVels?	123

SYSTem:MINPower?

Queries the lower power measurement limit. Use this query to determine a useful resolution for the result display near the lower measurement limit.

This value changes if [\[SENSe<Sensor>:\]CORRection:SPDevice:STATe](#) is set to ON.

The lower measurement limit refers to the sensor or to the combination of a sensor and the components connected ahead of it.

Set the unit using `SYSTem:MINPower:UNIT`.

Usage: Query only

`SYSTem:MINPower:UNIT <unit>`

Sets the unit for the lower power measurement limit, queried by `SYSTem:MINPower?`.

Parameters:

<unit> DBM | W | DBUV
*RST: W

`SYSTem:TLEvels?`

Queries the possible power test levels of the sensor.

Usage: Query only

8.11.10 Errors

See also [Section 12.2, "Error messages"](#), on page 152.

<code>SYSTem:ERRor:ALL?</code>	123
<code>SYSTem:ERRor:CODE:ALL?</code>	124
<code>SYSTem:ERRor:CODE[:NEXT]?</code>	124
<code>SYSTem:ERRor:COUNT?</code>	124
<code>SYSTem:ERRor[:NEXT]?</code>	124
<code>SYSTem:SERRor?</code>	125
<code>SYSTem:SERRor:LIST:ALL?</code>	125
<code>SYSTem:SERRor:LIST[:NEXT]?</code>	125

`SYSTem:ERRor:ALL?`

Queries all unread entries in the SCPI communication error queue and removes them from the queue.

Returns a comma-separated list of error numbers and a short error description in the first-in first-out order.

Example: `SYST:ERR:ALL?`
Query
0, "No error"
Response

Usage: Query only

SYSTem:ERRor:CODE:ALL?

Queries all unread entries in the SCPI communication error queue and removes them from the queue.

Returns a comma-separated list of error numbers, but no error description.

Example: SYST:ERR:CODE:ALL?
Query
0
Response: No errors have occurred since the error queue was last read out.

Usage: Query only

SYSTem:ERRor:CODE[:NEXT]?

Queries the SCPI communication error queue for the oldest entry and removes it from the queue.

Returns the error number, but no error description.

Example: SYST:ERR:CODE?
Query
0
Response: No errors have occurred since the error queue was last read out.

Usage: Query only

SYSTem:ERRor:COUNT?

Queries the number of entries in the SCPI communication error queue.

Example: SYST:ERR:COUN?
Query
1
Response: One error has occurred since the error queue was last read out.

Usage: Query only

SYSTem:ERRor[:NEXT]?

Queries the SCPI communication error queue for the oldest entry and removes it from the queue.

Returns an error number and a short description of the error.

Example: SYST:ERR?
Query
0, 'no error'
Response: No errors have occurred since the error queue was last read out.

Usage: Query only

SYSTem:SERRor?

Queries the next static error, if available.

Static errors, as a rule, prevent the execution of normal measurements.

Errors in SCPI communication are queried using `SYSTem:ERRor[:NEXT]?`.

Usage: Query only

SYSTem:SERRor:LIST:ALL?

Queries all changes in the static error queue that have not been read yet and removes them from the queue.

Example: `SYST:SERR:LIST:ALL?`
Query
 0,"reported at uptime:2942; notice;
 auto-averaging exceeded maximum time;
 Notification",0,"removed at uptime:2944;
 notice; auto-averaging exceeded
 maximum time; Notification"
Response

Usage: Query only

SYSTem:SERRor:LIST[:NEXT]?

Queries the list of static error changes for the oldest entry and removes it from the queue.

Returns an error number and a short description of the error.

Example: `SYST:SERR:LIST?`
Query
 0,"reported at uptime:2942; notice;
 auto-averaging exceeded maximum time;
 Notification"
Response

Usage: Query only

8.12 Using the status register

Further information:

- [Section 10.2, "Status reporting system"](#), on page 136

Contents:

• General status register commands.....	126
• Reading the CONDition part.....	126
• Reading the EVENT part.....	127
• Controlling the ENABle part.....	127
• Controlling the negative transition part.....	127
• Controlling the positive transition part.....	128

8.12.1 General status register commands

STATus:PRESet.....	126
STATus:QUEue[:NEXT]?.....	126

STATus:PRESet

Resets the edge detectors and ENABle parts of all registers to a defined value.

Usage: Event

STATus:QUEue[:NEXT]?

Queries the most recent error queue entry and deletes it.

Positive error numbers indicate sensor-specific errors. Negative error numbers are error messages defined by SCPI.

If the error queue is empty, the error number 0, "No error", is returned.

Usage: Query only

8.12.2 Reading the CONDition part

STATus:DEVIce:CONDition?
 STATus:OPERation:CALibrating:CONDition?
 STATus:OPERation:CONDition?
 STATus:OPERation:LLFail:CONDition?
 STATus:OPERation:MEASuring:CONDition?
 STATus:OPERation:SENSe:CONDition?
 STATus:OPERation:TRIGger:CONDition?
 STATus:OPERation:ULFail:CONDition?
 STATus:QUESTionable:CALibration:CONDition?
 STATus:QUESTionable:CONDition?
 STATus:QUESTionable:POWEr:CONDition?
 STATus:QUESTionable:WINDow:CONDition?
Usage: Query only

8.12.3 Reading the EVENT part

STATus:DEVIce[:EVENT]?
STATus:OPERation:CALibrating[:SUMMary][:EVENT]?
STATus:OPERation[:EVENT]?
STATus:OPERation:LLFail[:SUMMary][:EVENT]?
STATus:OPERation:MEASuring[:SUMMary][:EVENT]?
STATus:OPERation:SENSe[:SUMMary][:EVENT]?
STATus:OPERation:TRIGger[:SUMMary][:EVENT]?
STATus:OPERation:ULFail[:SUMMary][:EVENT]?
STATus:QUESTionable:CALibration[:SUMMary][:EVENT]?
STATus:QUESTionable[:EVENT]?
STATus:QUESTionable:POWER[:SUMMary][:EVENT]?
STATus:QUESTionable:WINDow[:SUMMary][:EVENT]?
Usage: Query only

8.12.4 Controlling the ENABLE part

STATus:DEVIce:ENABLE <value>
STATus:OPERation:CALibrating:ENABLE <value>
STATus:OPERation:ENABLE <value>
STATus:OPERation:LLFail:ENABLE <value>
STATus:OPERation:MEASuring:ENABLE <value>
STATus:OPERation:SENSe:ENABLE <value>
STATus:OPERation:TRIGger:ENABLE <value>
STATus:OPERation:ULFail:ENABLE <value>
STATus:QUESTionable:CALibration:ENABLE <value>
STATus:QUESTionable:ENABLE <value>
STATus:QUESTionable:POWER:ENABLE <value>
STATus:QUESTionable:WINDow:ENABLE <value>
Parameters:
 <value> *RST: 0

8.12.5 Controlling the negative transition part

STATus:DEVIce:NTRansition <value>
STATus:OPERation:CALibrating:NTRansition <value>
STATus:OPERation:NTRansition <value>
STATus:OPERation:LLFail:NTRansition <value>
STATus:OPERation:MEASuring:NTRansition <value>
STATus:OPERation:SENSe:NTRansition <value>
STATus:OPERation:TRIGger:NTRansition <value>
STATus:OPERation:ULFail:NTRansition <value>
STATus:QUESTionable:CALibration:NTRansition <value>
STATus:QUESTionable:NTRansition <value>

STATus:QUESTionable:POWer:NTRansition <value>
STATus:QUESTionable:WINDow:NTRansition <value>
Parameters:
<value> *RST: 0

8.12.6 Controlling the positive transition part

STATus:DEVIce:PTRansition <value>
STATus:OPERation:CALibrating:PTRansition <value>
STATus:OPERation:PTRansition <value>
STATus:OPERation:LLFail:PTRansition <value>
STATus:OPERation:MEASuring:PTRansition <value>
STATus:OPERation:SENSe:PTRansition <value>
STATus:OPERation:TRIGger:PTRansition <value>
STATus:OPERation:ULFail:PTRansition <value>
STATus:QUESTionable:CALibration:PTRansition <value>
STATus:QUESTionable:PTRansition <value>
STATus:QUESTionable:POWer:PTRansition <value>
STATus:QUESTionable:WINDow:PTRansition <value>
Parameters:
<value> *RST: 65535

9 Performing measurement tasks - programming examples

If you install the optional software development kit (SDK) of the R&S NRP-Toolkit, programming examples are provided. See [Section 5.1, "R&S NRP-Toolkit"](#), on page 34.

Under Windows, these examples are installed under:

```
C:\ProgramData\Rohde-Schwarz\NRP-Toolkit-SDK\examples
```

This section gives programming examples for measurement tasks performed with the NRP sensors.

9.1 Performing the simplest measurement

The simplest way to obtain a result is to use the following sequence of commands:

```
*RST
INITiate
FETCh?
```

The `*RST` sets the continuous average mode.

`INITiate` initiates the measurement.

After `*RST`, the trigger system is set to `TRIGger:SOURCE IMMEDIATE`. That means the sensor starts measuring when the measurement is started without waiting for a trigger condition.

After the measurement has been completed, `FETCh<Sensor>[:SCALar] [:POWER] [:AVG] ?` delivers the result to the output queue from which it can be fetched.

9.2 Performing a buffered continuous average measurement

This example, written in pseudo code, shows how to set up and execute a buffered continuous average measurement.

```
//Select whether using
//   'BUS Trigger'    --> true
// or 'EXT Trigger'  --> false
bool   bUseBUSTrigger = true;

// Use the first NRP series sensor which is found
if ( VI_SUCCESS == SENSOR.openFirstNrpSensor( "USB?::0X0AAD::?*::INSTR" ) )
{
    //Start with a clean state
    SENSOR.write( "*RST" );
}
```

Performing a buffered continuous average measurement

```
// Auto Averaging OFF and set Average Count = 4
SENSOR.write( "SENS:AVER:COUN:AUTO OFF" );
SENSOR.write( "SENS:AVER:COUN 4" );

// Select the trigger source
if ( bUseBUSTrigger )
{
    // We want to use '*TRG' to trigger a single physical measurement
    SENSOR.write( "TRIG:SOUR BUS" );
}
else
{
    // We get trigger pulses on the external input (SMB-type connector)
    SENSOR.write( "TRIG:SOUR EXT2" );
}
// Auto-Trigger OFF
SENSOR.write( "TRIG:ATR:STAT OFF" );

// Configure a buffered measurement
// Buffer size is randomly selected to 17
SENSOR.write( "SENS:BUFF:SIZE 17" );
SENSOR.write( "SENS:BUFF:STAT ON" );
SENSOR.write( "TRIG:COUN 17" );

// Read out all errors / Clear error queue
SENSOR.query( "SYST:ERR:ALL?", szBuf, sizeof( szBuf ) );
printf( szBuf );

// Start a 'single' buffered measurement
// Since 17 trigger-counts have been configured,
// the 'single' buffered measurement, which becomes
// initiated by INIT:IMM, is not over until
// 17 physical measurements have been triggered
SENSOR.write( "INIT:IMM" );

// The end of a physical measurement can be recognized
// by a transistion to 'NOT MEASURING' which is a
// negative transistion on bit 1
SENSOR.write( "STAT:OPER:MEAS:NTR 2" );
SENSOR.write( "STAT:OPER:MEAS:PTR 0" );

// Collect 17 physical measurements
for ( int i = 0; i < 17; i++ )
{
    // As a pre-condition: clear the event register by reading it
    int iDummy;
    SENSOR.query( "STAT:OPER:MEAS:EVEN?", &iDummy );
}
```

```
// Trigger a single physical measurement; either by '*TRG'
// command or by an externally supplied pulse on the SMB-type connector
if ( bUseBUSTrigger )
    SENSOR.write( "*TRG" );

// Wait until the measurement is done
int iMeasEvent = 0;
while ( iMeasEvent != 2 )
{
    SENSOR.query( "STAT:OPER:MEAS:EVEN?", &iMeasEvent );
    iMeasEvent &= 2;
}
printf( "Triggered!\n" );
}
// All 17 physical measurement have been executed.
// That means, buffer is full and can be read
SENSOR.query( "FETCH?", szBuf, sizeof( szBuf ) );
printf( szBuf );
}
```

10 Remote control basics

For general information on remote control of Rohde & Schwarz products via SCPI, refer to www.rohde-schwarz.com/rc-via-scp.

10.1 Remote control interfaces and protocols

For remote control, communication between the sensors and the controlling host is established based on various interfaces and protocols.

Depending on the sensor type, the sensors support different interfaces for remote control.

- USB sensors are always accessed using USB.
See [Section 10.1.1, "USB interface"](#), on page 132.
- LAN sensors can be accessed using USB or Ethernet.
See [Section 10.1.2, "Ethernet interface"](#), on page 134.

10.1.1 USB interface

Connect the computer and the sensors as described in:

- [Section 3.7.1.1, "Using a simple USB connection"](#), on page 19
- [Section 3.7.1.2, "Using R&S NRP-Z5 sensor hub setup"](#), on page 20

10.1.1.1 USBTMC protocol

The USB test & measurement class specification (USBTMC) is a protocol that is built on top of USB for communication with USB devices from the test & measurement category. It defines a dedicated class code that identifies a device's functionality. The device also uses this class code to identify itself as a member of the test & measurement class. Using a VISA library, such devices support service request, trigger and other operations that are commonly found in GPIB devices.

Computer requirements

- VISA library
VISA is a standardized software interface library providing input and output functions to communicate with instruments. A VISA installation on the controller is a prerequisite for remote control over USBTMC.
VISA detects and configures the product automatically when the USB connection is established.
- USBTMC driver
Apart from the USBTMC driver, which comes with the installation of VISA, you do not have to install a separate driver.

USB resource string

The VISA resource string for USBTMC device communication represents an addressing scheme that is used to establish a communication session with the product. It is based on the product address and some product- and vendor-specific information. The syntax of the used USB resource string is:

```
USB[board]::<vendor ID>::<product ID>::<serial number>[::INSTR]
```

- *<vendor ID>* is the vendor ID for Rohde & Schwarz, 0x0AAD.
- *<product ID>* is the product ID for the product.
- *<serial number>* is the individual serial number of the product, printed on the casing.

Example:

```
USB0::0x0AAD::0x01D1::100001::INSTR
```

0x0AAD is the vendor ID for Rohde & Schwarz.

0x01D1 is the product ID.

100001 is the serial number of the product.

Table 10-1: R&S NRPxTWG(N) USB product IDs

Model	USB product ID
R&S NRP75TWG	0x01D1
R&S NRP75TWGN	0x0294
R&S NRP90TWG	0x01D2
R&S NRP90TWGN	0x0295
R&S NRP110TWG	0x01D3
R&S NRP110TWGN	0x0296
R&S NRP140TWG	0x02AD
R&S NRP140TWGN	0x02AE
R&S NRP170TWG	0x02AF
R&S NRP170TWGN	0x02B0

10.1.1.2 NRP legacy protocol

The NRP legacy protocol is available to ensure the compatibility of the sensors with the R&S NRP-Z sensors. The usage of this protocol is not recommended for new applications.

Computer requirements

- VISA library
VISA is a standardized software interface library providing input and output functions to communicate with instruments. A VISA installation on the controller is a prerequisite for remote control over USB.

VISA detects and configures the product automatically when the USB connection is established.

- USB device drivers
Apart from the USB device drivers that come with the installation of the R&S NRP-Toolkit, you do not have to install a separate driver.

10.1.2 Ethernet interface

Requires a sensor with networking capabilities, a LAN sensor.

Using the Ethernet interface, you can integrate the product in a local area network (LAN).

Connect the computer and the sensors as described in [Section 3.7.4, "Using a LAN connection"](#), on page 24.

10.1.2.1 Requirements

Local area network

The local area network must support the TCP/IP network protocol.

The TCP/IP network protocol and the associated network services are preconfigured on the product.

Computer

- VISA library
VISA is a standardized software interface library providing input and output functions to communicate with instruments. A VISA installation on the controller is a prerequisite for remote control over LAN when using VXI-11 or HiSLIP protocols.
- Software for device control

10.1.2.2 Protocols

- VXI-11
See ["VXI-11"](#) on page 135.
- HiSLIP: High-speed LAN instrument protocol (IVI-6.1)
See ["HiSLIP"](#) on page 135.
- Socket communication (LAN Ethernet)
See ["Socket communication"](#) on page 135.

10.1.2.3 VISA resource strings

The VISA resource string is required to establish a communication session between the controller and the product in a LAN. The resource string is a unique identifier, composed of the specific IP address of the product and some network and VISA-specific keywords.

TCPIP::*<IP address or host name>*::*<LAN device name>*::INSTR]

- *TCPIP* designates the network protocol used.
- *<IP address or host name>* is the IP address or host name of the device.
- [*<LAN device name>*] defines the protocol and the instance number of a subinstrument.
- [*:INSTR*] indicates the product resource class (optional).

The IP address or host name is used by the programs to identify and control the product. While the host name is determined by settings in the product, the IP address is assigned by a DHCP server when the product requests one. Alternatively the IP address is determined with a procedure called zeroconf.

You can also assign a *LAN device name* which defines the protocol characteristics of the connection. See the description of the VISA resource string below for the corresponding interface protocols. The string of the *LAN device name* is emphasized in italics.

VXI-11

TCPIP::*<IP address or host name>*::*inst0*::INSTR]

inst0 is the LAN device name, indicating that the VXI-11 protocol is used (optional)

inst0 currently selects the VXI-11 protocol by default and can be omitted.

Examples:

- If the product has the IP address *10.111.11.20*, the valid resource string is TCPIP::*10.111.11.20*::INSTR
- If the DNS host name is *nrp75twgn-100001*, the valid resource string is TCPIP::*nrp75twgn-100001*::inst0

HiSLIP

TCPIP::*<IP address or host name>*::*hislip0*::INSTR]

hislip0 is the HiSLIP device name, designates that the interface protocol HiSLIP is used (mandatory)

hislip0 is composed of [*:HiSLIP device name*[,HiSLIP port]] and must be assigned.

Example:

If the DNS host name is *nrp75twgn-100001*, the valid resource string is

TCPIP::*nrp75twgn-100001*::hislip0

Socket communication

TCPIP::*<IP address or host name>*::*port*::SOCKET

- *port* determines the used port number.
- *SOCKET* indicates the raw network socket resource class.

Socket communication requires the specification of the port (commonly referred to as port number) and of *SOCKET* to complete the VISA resource string with the associated protocol used.

The default port for socket communication is port 5025.

Examples:

- TCPIP::10.111.11.20::5025::SOCKET
- TCPIP::nrp75twgn-100001::5025::SOCKET

10.2 Status reporting system

The status reporting system stores all information on the current operating state of the instrument, and on errors which have occurred. This information is stored in the status registers and in the error queue. You can query both with the commands of the `STATus` subsystem.

10.2.1 Overview

Fig.10-1 shows the hierarchical structure of information in the status registers.

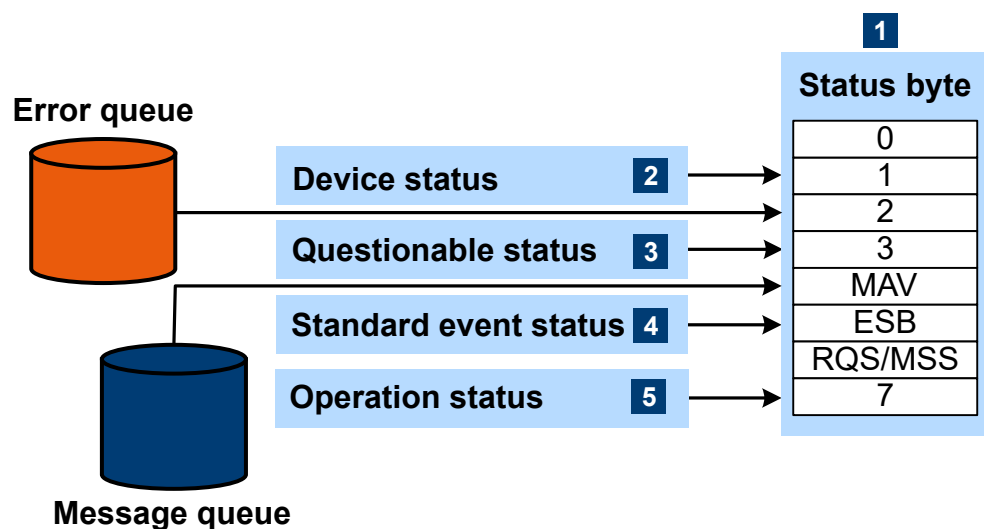

Figure 10-1: Status registers overview

1 = Status byte, see Table 10-2

2 = Section 10.2.2, "Device status register", on page 137

3 = Section 10.2.3, "Questionable status register", on page 139

4 = Section 10.2.4, "Standard event status and enable register (ESR, ESE)", on page 142

5 = Section 10.2.5, "Operation status register", on page 143

The highest level is formed by the status byte register (STB) and the associated service request enable (SRE) register.

The status byte register (STB) receives its information from:

- Standard event status register (ESR)
- Associated standard event status enable register (ESE)
- SCPI-defined operation status register

- Questionable status register, which contains detailed information on the device.

Table 10-2: Used status byte bits and their meaning

Bit no.	Short description	Bit is set if
1	Device status register summary	An instrument is connected or disconnected or when an error has occurred in an instrument, depending on the configuration of the instrument status register. Section 10.2.2, "Device status register" , on page 137.
2	Error queue not empty	The error queue has an entry. If this bit is enabled by the service request enable register, each entry of the error queue generates a service request. An error can thus be recognized and specified in detail by querying the error queue. The query yields a conclusive error message. This procedure is recommended since it considerably reduces the problems of IEC/IEEE bus control.
3	Questionable status register summary	An <code>EVENT</code> bit is set in the <code>QUESTIONABLE</code> status register and the associated <code>ENABLE</code> bit is set to 1. A set bit denotes a questionable device status which can be specified in greater detail by querying the questionable status register. Section 10.2.3, "Questionable status register" , on page 139.
4	MAV Message available	A readable message is in the message queue. This bit can be used to read data automatically from the instrument into the controller.
5	ESB Standard event status register summary	One of the bits in the standard event status register is set and enabled in the event status enable register. Setting this bit denotes a serious error which can be specified in greater detail by querying the standard event status register. Section 10.2.4, "Standard event status and enable register (ESR, ESE)" , on page 142.
6	RQS/MSS Primary status summary	The instrument triggers a service request. The service request happens if one of the other bits of this register is set together with its enable bit in the service request enable register (SRE).
7	Operation status register summary	An <code>EVENT</code> bit is set in the operation status register and the associated <code>ENABLE</code> bit is set to 1. A set bit denotes that an action is being performed by the instrument. Information on the type of action can be obtained by querying the operation status register. Section 10.2.5, "Operation status register" , on page 143.

Further information:

- See [Figure 10-1](#).
- Set and read the service request enable register using `*SRE`.

10.2.2 Device status register

Shows whether static errors (SERR) exist and other sensor status information.

Sum of bits 1 to 4	0
Measurement not possible	1
Erroneous result	2
Warning	3
Critical	4
0	5
0	6
Legacy locked state	7
Reference PLL locked state	8
0	9
0	10
0	11
0	12
0	13
0	14
0	15

Figure 10-2: Device status register

Querying the register:

- `STATus:DEvice:CONDition?`
- `STATus:DEvice[:EVENT]?`

Querying the static errors:

- `SYSTem:SERRor?`

Table 10-3: Used device status bits and their meaning

Bit no.	Short description	Bit is set if
0	Sum of bits 1 to 4	Sum/combination of static error (SERR) bits 1 to 4.
1	Measurement not possible	Static error exists. Certain parameter settings could lead to a situation where subsequent measurements are not possible.
2	Erroneous results	Static error exists. The measurement result is possibly incorrect.
3	Warning	Static error exists. The status LED of the sensor is slowly flashing red.
4	Critical	Critical static error exists. The status LED of the sensor is fast flashing red.

Bit no.	Short description	Bit is set if
7	Legacy locked state	<p>The sensor is locked in the NRP legacy mode. Via the SCPI channels (USBTMC or TCP/IP), only query commands can be sent, but no setting commands.</p> <p>When the first setting command is sent, the NRP legacy interface takes precedence over all other command channels. This bit is set to 1, and all other channels can only execute query commands. If a setting command is sent via a different channel, the sensor indicates an error:</p> <p><i>-200,"Execution error; sensor in LEGACY mode"</i></p> <p>To leave the NRP legacy mode, close the NRP legacy channel. Either close the application which opened the NRP legacy channel or close at least the connection to the sensor.</p>
8	Reference PLL locked state	<p>PLL for the clock reference is synchronized. The bit is useful when selecting an external clock source.</p> <p>The following states are possible:</p> <ul style="list-style-type: none"> • Internal clock ([SENSe<Sensor>:]ROSCillator: SOURce INT): <ul style="list-style-type: none"> – 1 (always) • External clock ([SENSe<Sensor>:]ROSCillator: SOURce EXT): <ul style="list-style-type: none"> – 1 if the sensor was able to synchronize with external clock – 0 if the sensor could not synchronize with external clock

10.2.3 Questionable status register

Contains information on questionable sensor states that occur if the sensor is not operated in compliance with its specifications.

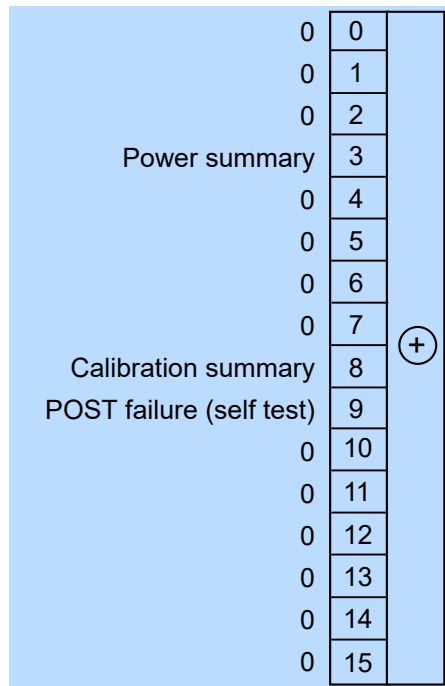

Figure 10-3: Questionable status register

Querying the register:

- `STATUS:QUESTIONable:CONDition?`
- `STATUS:QUESTIONable[:EVENT]?`

Table 10-4: Used questionable status bits and their meaning

Bit no.	Short description	Bit is set if
3	Power summary	Summary of Questionable power status register exists.
8	Calibration summary	Summary of Questionable calibration status register exists.
9	POST failure (self-test)	Built-in test of the R&S NRPxTWG(N) that is carried out automatically upon power-up has generated an error.

10.2.3.1 Questionable power status register

Contains information on whether the measured power values are questionable.

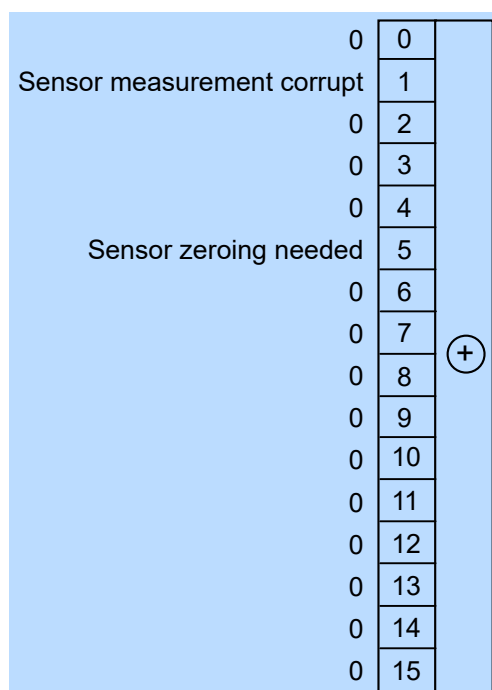

Figure 10-4: Questionable power status register

Querying the register:

- `STATUS:QUESTIONABLE:POWER:CONDITION?`
- `STATUS:QUESTIONABLE:POWER[:SUMMARY][:EVENT]?`

Table 10-5: Used questionable power status bits and their meaning

Bit no.	Short description	Bit is set if
1	Sensor measurement corrupt	Measurement data of the sensor is corrupt.
5	Sensor zeroing needed	Zero correction for the sensor is no longer correct. Perform a zero correction.

10.2.3.2 Questionable calibration status register

Contains information whether the zeroing of the sensor was successful.

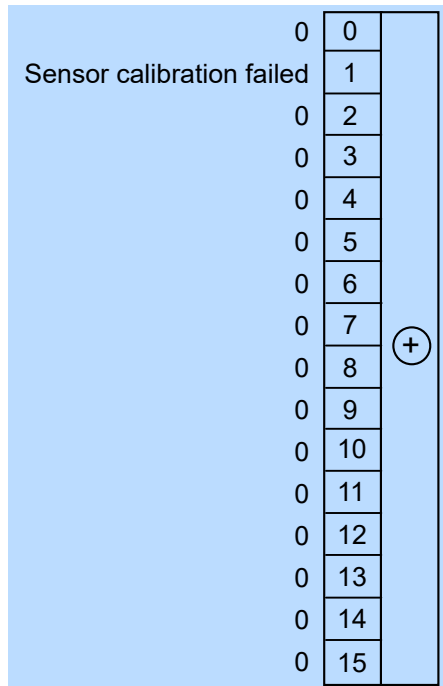

Figure 10-5: Questionable calibration status register

Querying the register:

- `STATUS:QUESTIONABLE:CALIBRATION:CONDITION?`
- `STATUS:QUESTIONABLE:CALIBRATION[:SUMMARY] [:EVENT]?`

Table 10-6: Used questionable calibration status bits and their meaning

Bit no.	Short description	Bit is set if
1	Sensor calibration failed	Zeroing of the sensor was not successful.

10.2.4 Standard event status and enable register (ESR, ESE)

The `ESR` is already defined in the IEEE 488.2 standard. It is comparable to the `EVENT` register of a SCPI register. The standard event status register can be read out by `*ESR?`.

The `ESE` forms the associated `ENABLE` register. It can be set and read by `*ESE`.

Operation Complete	0	+
0	1	
Query Error	2	
Device-Dependent Error	3	
Execution Error	4	
Command Error	5	
User Request	6	
Power On	7	

Figure 10-6: Standard event status register (ESR)

Table 10-7: Used standard event status bits and their meaning

Bit no.	Short description	Bit is set if
0	Operation complete	All previous commands have been executed and *OPC is received.
2	Query error	The controller wants to read data from the instrument but has not sent a query, or it sends new commands to the instrument before it retrieves existing requested data. A frequent cause is a faulty query which cannot be executed.
3	Device-dependent error	An instrument-dependent error occurs. An error message with a number between -300 and -399 or a positive error number denoting the error in greater detail is entered in the error queue.
4	Execution error	The syntax of a received command is correct but the command cannot be executed due to various marginal conditions. An error message with a number between -200 and -300 denoting the error in greater detail is entered in the error queue.
5	Command error	An undefined command or a command with incorrect syntax is received. An error message with a number between -100 and -200 denoting the error in greater detail is entered in the error queue.
6	User request	The instrument is switched over to manual control.
7	Power on	The instrument is switched on.

10.2.5 Operation status register

Contains information on current operations, CONDition register, or operations performed since the last query, EVENT register.

Calibrating	0	+
0	1	
0	2	
0	3	
Measuring	4	
Triggering	5	
0	6	
0	7	
0	8	
0	9	
Sense summary	10	
Lower limit fail	11	
Upper limit fail	12	
0	13	
0	14	
0	15	

Figure 10-7: Operation status register

Querying the register:

- `STATus:OPERation:CONDition?`
- `STATus:OPERation[:EVENT]?`

Table 10-8: Used operation status bits and their meaning

Bit no.	Short description	Bit is set if
0	Calibrating	Summary of Operation calibrating status register exists.
4	Measuring	Summary of Operation measuring status register exists.
5	Triggering	Summary of Operation trigger status register exists.
10	Sense summary	Summary of Operation sense status register exists.
11	Lower limit fail	Summary of Operation lower limit fail status register exists.
12	Upper limit fail	Summary of Operation upper limit fail status register exists.

10.2.5.1 Operation calibrating status register

The `CONDition` register contains information on whether a sensor is being calibrated. The `EVENT` register contains information on whether a calibration was started or completed since the last query.

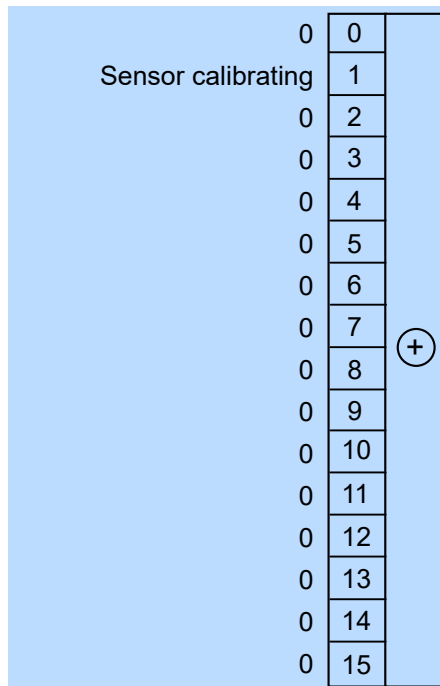

Figure 10-8: Operation calibrating status register

Querying the register:

- `STATUS:OPERation:CALibrating:CONDition?`
- `STATUS:OPERation:CALibrating[:SUMMARY][:EVENT]?`

Table 10-9: Used operation calibrating status bits and their meaning

Bit no.	Short description	Bit is set if
1	Sensor calibrating	Sensor is being calibrated.

10.2.5.2 Operation measuring status register

The `CONDition` register contains information on whether a sensor is measuring. The `EVENT` register contains information on whether a measurement was started or completed since the last query.

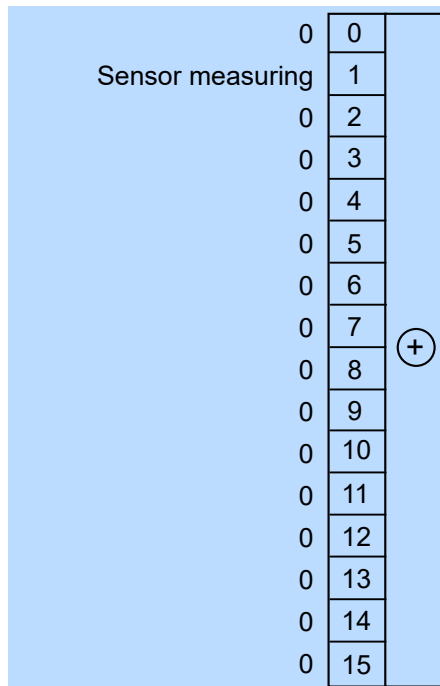

Figure 10-9: Operation measuring status register

Querying the register:

- `STATUS:OPERation:MEASuring:CONDition?`
- `STATUS:OPERation:MEASuring[:SUMMARY][:EVENT]?`

Table 10-10: Used operation measuring status bits and their meaning

Bit no.	Short description	Bit is set if
1	Sensor measuring	Sensor is measuring.

10.2.5.3 Operation trigger status register

The `CONDition` register contains information whether a sensor is waiting for a trigger event. The `EVENT` register contains information on whether the sensor has been waiting for a trigger event since the last query.

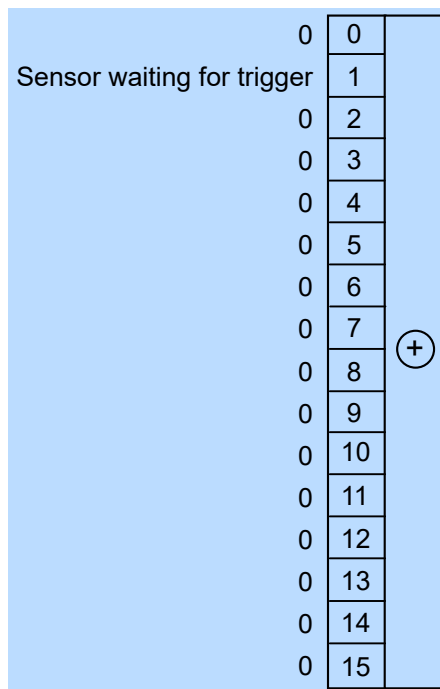

Figure 10-10: Operation trigger status register

Querying the register:

- `STATUS:OPERation:TRIGger:CONDition?`
- `STATUS:OPERation:TRIGger[:SUMMARY][:EVENT]?`

Table 10-11: Used operation trigger status bits and their meaning

Bit no.	Short description	Bit is set if
1	Sensor waiting for trigger	Sensor is waiting for a trigger event. When the trigger event occurs, the sensor changes into the measuring state.

10.2.5.4 Operation sense status register

The `CONDition` register contains information whether a sensor is being initialized. The `EVENT` register contains information whether an initialization was started or completed since the last query.

A sensor is initialized if:

- Supply voltage is switched on (power-up).
- Sensor was connected.
- Reset was performed using:
 - `*RST`
 - `SYSTEM:PRESet`

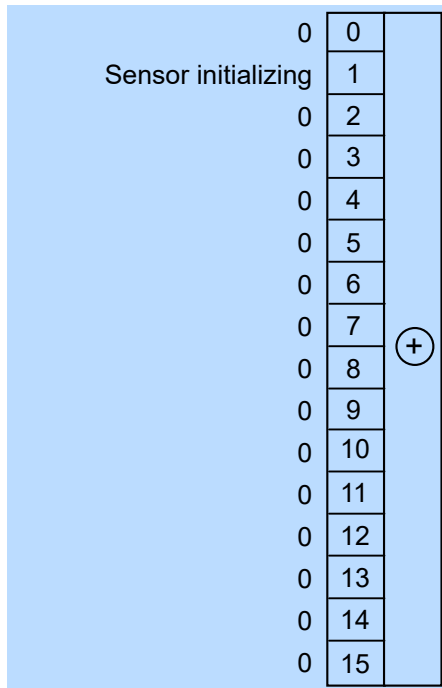

Figure 10-11: Operation sense status register

Querying the register:

- `STATUS:OPERation:SENSe:CONDition?`
- `STATUS:OPERation:SENSe[:SUMMARY][:EVENT]?`

Table 10-12: Used operation sense status bits and their meaning

Bit no.	Short description	Bit is set if
1	Sensor initializing	Sensor is being initialized.

10.2.5.5 Operation lower limit fail status register

The `CONDition` registers contain information whether a measured value is below a configured lower limit. The `EVENT` registers contain information on whether a measured value dropped below a limit value since the last query.

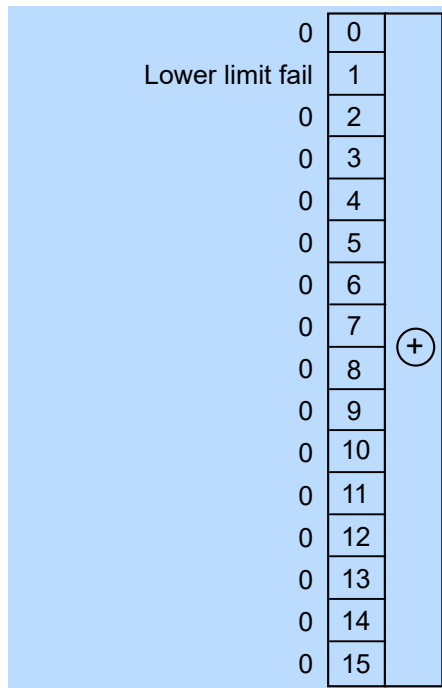

Figure 10-12: Operation lower limit fail status registers

Querying the register:

- `STATUS:OPERation:LLFail:CONDition?`
- `STATUS:OPERation:LLFail[:SUMMary][:EVENT]?`

Table 10-13: Used operation lower limit fail status bits and their meaning

Bit no.	Short description	Bit is set if
1	Lower limit fail	Measured value is below the lower limit value.

10.2.5.6 Operation upper limit fail status register

The `CONDition` registers contain information on whether a measured value currently exceeds a configured upper limit. The `EVENT` registers contain information on whether a measured value exceeded an upper limit value since the last query.

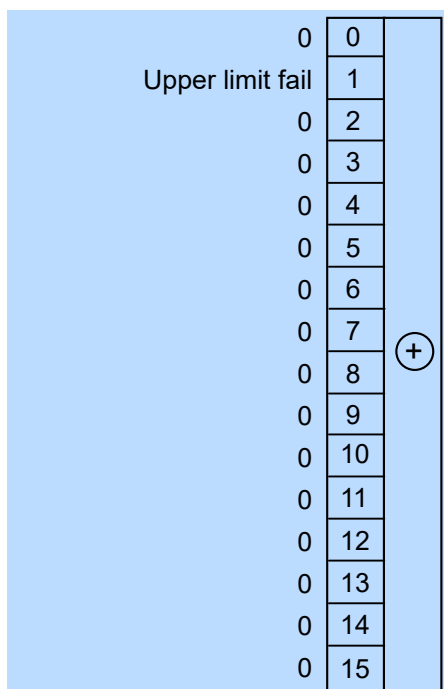

Figure 10-13: Operation upper limit fail status registers

Querying the register:

- `STATUS:OPERation:ULFail:CONDition?`
- `STATUS:OPERation:ULFail[:SUMMary][:EVENT]?`

Table 10-14: Used operation upper limit fail status bits and their meaning

Bit no.	Short description	Bit is set if
1	Upper limit fail	Measured value exceeds the upper limit value.

11 Data management

Depending on the origin and content, this description distinguishes between the following data types:

- Operational data
- Non-operational data

Operational data (data for intended use)

The power sensor uses and creates this data because of its intended use and according to the settings and configuration you have made. Thus, this data makes up most of the data that the R&S NRPxTWG(N) creates, such as user files that contain user-defined configurations or data, like sensor settings or measurement data.

Non-operational data (usage data)

The R&S NRPxTWG(N) creates this data during and through its use. Such data is collected e.g. for troubleshooting, to help our customer support center find solutions quickly.

The R&S NRPxTWG(N) generates this data continuously and in real-time. This data is saved on the power sensor. The power sensor is not capable of storing this data on a remote server.

The R&S NRPxTWG(N) generates the following data and saves it in the non-volatile memory:

- Diagnostic and troubleshooting data
On demand, this data is returned as block data containing a compressed archive of files in text and binary format. The volume of the non-operational data depends on the usage of the product and typically amounts to about 20 kbyte.
You can access, retrieve and delete this data. See [Section 12.6, "Collecting information for technical support"](#), on page 156.

The R&S NRPxTWG(N) generates the following data and saves it temporarily. When you disconnect the power sensor from its power source, this data is deleted.

- Environmental conditions
You can access and retrieve this data using the `TEST:SENSoR?` command.
- Hardware component metadata
You can access and retrieve this data using the `SYSTem:DFPPrint<Channel>?` command.

For additional information on the different memory types and on how to clear the internal memory to protect sensitive data, see the instrument security procedures document at:

www.rohde-schwarz.com/manual/nrp-t-tn

12 Troubleshooting

• Displaying status information	152
• Error messages	152
• Performing a self-test	153
• Problems during a firmware update	155
• Cannot establish a LAN connection	156
• Collecting information for technical support	156
• Contacting customer support	156

12.1 Displaying status information

Status information is available in several ways.

Status LED of the sensor

The position of the status LED is indicated in:

[Section 4, "Sensor tour"](#), on page 30.

The meaning of the different colors and flashing frequencies is explained in:

[Table 4-2](#).

Title bar of the web user interface

Requires a sensor with networking capabilities, a LAN sensor.

The position of the status icon is indicated in:

[Figure 6-1](#)

The colors are explained in:

[Section 4.2, "Status information"](#), on page 31.

12.2 Error messages

Querying errors (remote control)

In remote control, the commands querying errors are part of `SYSTEM`.

See [Section 8.11, "Configuring the system"](#), on page 110.

The severity of the error is distinguished:

- Normal error
Results from, for example, unknown commands or syntax errors and generally affect a single parameter or setting.
- Static error

More severe than a normal error. Prevents the execution of normal measurements.

Positive error numbers are instrument-dependent. Negative error numbers are reserved by the SCPI standard.

You can query the error queue using:

- `SYSTem:ERRor:ALL?`
- `SYSTem:ERRor:COUNT?`
- `SYSTem:ERRor[:NEXT]?`

If you want to look only at static errors, use:

- `SYSTem:SERRor?`
- `SYSTem:SERRor:LIST[:NEXT]?`

12.3 Performing a self-test

The self-test gives you detailed information that you can use for troubleshooting.



Do not apply a signal to the sensor while the self-test is running. If the self-test is carried out with a signal being present, error messages can erroneously be output for the following test steps:

- Offset Voltages
- Noise Voltage

Using the web user interface (LAN sensors)

1. In the navigation pane of the main dialog, select "Sensor".
2. Under "Diagnostics", click "Selftest".
See also "[Selftest](#)" on page 51.

Using remote control

- For a quick check, send:

`TEST:SENSor?`

For each test step, PASS or FAIL is listed.

```
Operating Voltages:
+3V3_VCC_MIO:      PASS (+3.26 V)
+1V8_PS:          PASS (+1.78 V)
+1V0_PS:          PASS (+0.97 V)
+3V3_VCC_13:      PASS (+3.29 V)
+2V5_VCC_34:      PASS (+2.36 V)
+1V8_VCC_35:      PASS (+1.80 V)
+1V8_PL:          PASS (+1.76 V)
+1V0_PL:          PASS (+0.99 V)
+1V8_LPDDR2_CORE: PASS (+1.79 V)
```

```
+1V2_LPDDR2:      PASS (+1.27 V)
+0V6_VREF_LPDDR2: PASS (+0.60 V)
+1V25_VREF:       PASS (+1.24 V)
+2V5_ANALOG:      PASS (+2.50 V)
-2V5_ANALOG:      PASS (-2.53 V)
VREF_ANALOG:      PASS (+4.089 V)

Temperatures:
  Detector Temperature:    PASS (+24.4 deg C)
  Analog Board Temperature: PASS (+24.4 deg C)
  Digital Board Temperature: PASS (+37.0 deg C)
Offset Voltages: PASS (+0.0036 mV, +0.0037 mV)
Noise Voltage: PASS (0.95 uV)
Test Heater Power Drift: PASS (-0.02 %)
```

12.3.1 Interpreting the test results

If all test steps or parts pass, the overall result is PASS. If one test step or a part of it fails, the overall result is FAIL. What you need to do in this case is described in the following.

Operating Voltages, Reference Voltages, Offset Voltages, Noise Voltage

Checks the voltages.

If the test fails:

1. Disconnect all signal sources and connectors except LAN or USB.
2. Perform the self-test again.
If it fails again, a hardware defect is probable.
3. Contact the customer support.

Calibration Data

Checks the integrity of the calibration data sets.

If the test fails:

1. Perform the self-test again.
If it fails again, the sensor has to be calibrated.
2. Contact the customer support.

Temperatures

Checks the temperature at several measurement points, whether they are plausible and whether the limits are met.

Is the ambient temperature OK?

- ▶ Check whether the ambient temperature lies within the range rated in the specifications document of the R&S NRPxTWG(N).

If the ambient temperature is higher or lower, adjust the air conditioning of the room or move the test setup into a room with a fitting temperature.

12.4 Problems during a firmware update

Further information:

- Firmware update. See [Section 7, "Firmware update"](#), on page 54.

Sensor is not in the "Device" list

If you do not find the sensor in the "Device" list, the driver assigned to the sensor is the legacy driver.

- ▶ Install a recent VISA software.

Sensor is highlighted in the Windows device manager

If the sensor is highlighted by a yellow exclamation mark in the Windows device manager, Windows tries in vain to find a USB driver for the sensor.

- ▶ Install a recent VISA software.

Firmware update was interrupted

If for example, a power cut happened during the firmware update, problems can occur.

1. Perform the firmware update again. Sometimes, a further update fixes the problems.
2. If the sensor is not accessible anymore, contact the service.

Firmware update was aborted

If there is not enough free storage space, the firmware update is aborted. An error message is displayed, and the status LED of the sensor starts flashing red.

1. Perform a sanitization procedure, as described in the instrument security procedures. This document is available on the product page.
,See [Section 2.1, "Documentation overview"](#), on page 12.
2. Perform the firmware update again.

12.5 Cannot establish a LAN connection

If you have problems to establish a LAN connection, try the following measures:

- Use the Configure Network Sensor component of the R&S NRP-Toolkit, see "[Configure Network Sensor](#)" on page 36.
- "[Troubleshooting for peer-to-peer connections](#)" on page 27

12.6 Collecting information for technical support

If you encounter problems that you cannot solve yourself, contact your Rohde & Schwarz support center, see [Section 12.7, "Contacting customer support"](#), on page 156. Our support center staff is optimally trained to assist you in solving problems.

The support center finds solutions more quickly and efficiently if you provide them with information on the instrument and an error description.

Obtaining information from the sensor firmware

To create, collect and save the diagnostic and troubleshooting data, use the remote control. See [SYSTEM:INFO:SUPPORT?](#) on page 120.

Collect also the error information. See [Section 12.2, "Error messages"](#), on page 152.

Attach the collected information to an email in which you describe the problem.

If you need to transport or ship the product, see [Section 13, "Transporting"](#), on page 158.

12.7 Contacting customer support

Technical support – where and when you need it

For quick, expert help with any Rohde & Schwarz product, contact our customer support center. A team of highly qualified engineers provides support and works with you to find a solution to your query on any aspect of the operation, programming or applications of Rohde & Schwarz products.

Contact information

Contact our customer support center at www.rohde-schwarz.com/support, or follow this QR code:



Figure 12-1: QR code to the Rohde & Schwarz support page

13 Transporting

Packing

Use the original packaging material. It consists of antistatic wrap for electrostatic protection and packing material designed for the product.

If you do not have the original packaging, use similar materials that provide the same level of protection. You can also contact your local Rohde & Schwarz service center for advice.

Securing

When moving the product in a vehicle or using transporting equipment, make sure that the product is properly secured. Only use items intended for securing objects.

Transport altitude

The maximum transport altitude without pressure compensation is specified in the specifications document.

14 Maintenance, storage and disposal

We advise to check the nominal data from time to time.

14.1 Cleaning

1. Disconnect the R&S NRPxTWG(N):
 - a) From the DUT.
 - b) From the computer or the base unit.
2. Clean the outside of the product using a lint-free cloth. You can dampen the cloth with water but keep in mind that the casing is not waterproof. If you use 70% isopropyl alcohol instead of water, be careful not to damage the labeling. Do not use cleaning agents that can damage the instrument such as acetone, acids or alkalis.
3. Clean the waveguide flanges using a foam swab or lint-free cloth dampened with isopropyl alcohol or ethanol. Avoid scratching the contact surfaces of the waveguide flanges.

Further information:

- ["To disconnect from the DUT"](#) on page 17
- Application note [1MA99](#): "Guidance on Selecting and Handling Coaxial RF Connectors used with Rohde & Schwarz Test Equipment"

14.2 Storage

Put plastic end caps on the RF connectors to protect them from damage. Protect the product against dust.

Ensure that the environmental conditions, e.g. temperature range and climatic load, meet the values specified in the specifications document.

14.3 Disposal

Rohde & Schwarz is committed to making careful, ecologically sound use of natural resources and minimizing the environmental footprint of our products. Help us by disposing of waste in a way that causes minimum environmental impact.

Disposing of electrical and electronic equipment

A product that is labeled as follows cannot be disposed of in normal household waste after it has come to the end of its life. Even disposal via the municipal collection points for waste electrical and electronic equipment is not permitted.



Figure 14-1: Labeling in line with EU directive WEEE

Rohde & Schwarz has developed a disposal concept for the eco-friendly disposal or recycling of waste material. As a manufacturer, Rohde & Schwarz completely fulfills its obligation to take back and dispose of electrical and electronic waste. Contact your local service representative to dispose of the product.

List of commands

[SENSe<Sensor>:][POWer:][AVG:]APeRture.....	81
[SENSe<Sensor>:][POWer:][AVG:]BUFFer:CLear.....	106
[SENSe<Sensor>:][POWer:][AVG:]BUFFer:COUNT?.....	106
[SENSe<Sensor>:][POWer:][AVG:]BUFFer:DATA?.....	106
[SENSe<Sensor>:][POWer:][AVG:]BUFFer:SIZE.....	106
[SENSe<Sensor>:][POWer:][AVG:]BUFFer:STATe.....	107
[SENSe<Sensor>:][POWer:][AVG:]SMOothing:STATe.....	81
[SENSe<Sensor>:]AVERage:COUNT.....	83
[SENSe<Sensor>:]AVERage:COUNT:AUTO.....	83
[SENSe<Sensor>:]AVERage:COUNT:AUTO:MTIME.....	83
[SENSe<Sensor>:]AVERage:COUNT:AUTO:NSRatio.....	84
[SENSe<Sensor>:]AVERage:COUNT:AUTO:RESolution.....	84
[SENSe<Sensor>:]AVERage:COUNT:AUTO:TYPE.....	84
[SENSe<Sensor>:]AVERage:RESet.....	85
[SENSe<Sensor>:]AVERage:TCONtrol.....	86
[SENSe<Sensor>:]AVERage[STATe].....	85
[SENSe<Sensor>:]CORRection:DCYClE.....	87
[SENSe<Sensor>:]CORRection:DCYClE:STATe.....	88
[SENSe<Sensor>:]CORRection:OFFSet.....	88
[SENSe<Sensor>:]CORRection:OFFSet:STATe.....	88
[SENSe<Sensor>:]CORRection:SPDeVice:LIST?.....	89
[SENSe<Sensor>:]CORRection:SPDeVice:SElect.....	89
[SENSe<Sensor>:]CORRection:SPDeVice:STATe.....	89
[SENSe<Sensor>:]FREQuency.....	86
[SENSe<Sensor>:]FUNction.....	66
[SENSe<Sensor>:]IGAMma:EUNCertainty?.....	93
[SENSe<Sensor>:]IGAMma:MAGNitude?.....	92
[SENSe<Sensor>:]IGAMma:PHASe?.....	92
[SENSe<Sensor>:]ROSCillator:SOURce.....	65
[SENSe<Sensor>:]SGAMma:CORRection:STATe.....	91
[SENSe<Sensor>:]SGAMma:MAGNitude.....	91
[SENSe<Sensor>:]SGAMma:PHASe.....	91
*CLS.....	62
*ESE.....	62
*ESR?.....	62
*IDN?.....	62
*IST?.....	62
*OPC.....	63
*OPT?.....	63
*PRE.....	63
*RCL.....	63
*RST.....	63
*SAV.....	64
*SRE.....	64
*STB?.....	64
*TRG.....	64
*TST?.....	64

*WAI.....	65
ABORT.....	67
CALibration:DATA.....	108
CALibration:DATA:LENGth?.....	108
CALibration:TEST:DEVIation?.....	108
CALibration:TEST:REFerence?.....	109
CALibration:TEST?.....	108
CALibration:USER:DATA.....	109
CALibration:USER:DATA:LENGth?.....	109
CALibration<Channel>:ZERO:AUTO.....	109
FETCh<Sensor>:ARRay[:POWer][:AVG]?.....	105
FETCh<Sensor>[:SCALar][:POWer][:AVG]?.....	106
FORMat:BORDER.....	104
FORMat:SREGister.....	105
FORMat[:DATA].....	104
INITiate:ALL.....	67
INITiate:CONTInuous.....	67
INITiate[:IMMediate].....	67
STATus:DEVIce:CONDition?.....	126
STATus:DEVIce:ENABle.....	127
STATus:DEVIce:NTRansition.....	127
STATus:DEVIce:PTRansition.....	128
STATus:DEVIce[:EVENT]?.....	127
STATus:OPERation:CALibrating:CONDition?.....	126
STATus:OPERation:CALibrating:ENABle.....	127
STATus:OPERation:CALibrating:NTRansition.....	127
STATus:OPERation:CALibrating:PTRansition.....	128
STATus:OPERation:CALibrating[:SUMMary][:EVENT]?.....	127
STATus:OPERation:CONDition?.....	126
STATus:OPERation:ENABle.....	127
STATus:OPERation:LLFail:CONDition?.....	126
STATus:OPERation:LLFail:ENABle.....	127
STATus:OPERation:LLFail:NTRansition.....	127
STATus:OPERation:LLFail:PTRansition.....	128
STATus:OPERation:LLFail[:SUMMary][:EVENT]?.....	127
STATus:OPERation:MEASuring:CONDition?.....	126
STATus:OPERation:MEASuring:ENABle.....	127
STATus:OPERation:MEASuring:NTRansition.....	127
STATus:OPERation:MEASuring:PTRansition.....	128
STATus:OPERation:MEASuring[:SUMMary][:EVENT]?.....	127
STATus:OPERation:NTRansition.....	127
STATus:OPERation:PTRansition.....	128
STATus:OPERation:SENSe:CONDition?.....	126
STATus:OPERation:SENSe:ENABle.....	127
STATus:OPERation:SENSe:NTRansition.....	127
STATus:OPERation:SENSe:PTRansition.....	128
STATus:OPERation:SENSe[:SUMMary][:EVENT]?.....	127
STATus:OPERation:TRIGger:CONDition?.....	126
STATus:OPERation:TRIGger:ENABle.....	127
STATus:OPERation:TRIGger:NTRansition.....	127

STATus:OPERation:TRIGger:PTRansition.....	128
STATus:OPERation:TRIGger[:SUMMary][:EVENT]?	127
STATus:OPERation:ULFail:CONDition?	126
STATus:OPERation:ULFail:ENABle.....	127
STATus:OPERation:ULFail:NTRansition.....	127
STATus:OPERation:ULFail:PTRansition.....	128
STATus:OPERation:ULFail[:SUMMary][:EVENT]?	127
STATus:OPERation[:EVENT]?	127
STATus:PRESet.....	126
STATus:QUEStionable:CALibration:CONDition?	126
STATus:QUEStionable:CALibration:ENABle.....	127
STATus:QUEStionable:CALibration:NTRansition.....	127
STATus:QUEStionable:CALibration:PTRansition.....	128
STATus:QUEStionable:CALibration[:SUMMary][:EVENT]?	127
STATus:QUEStionable:CONDition?	126
STATus:QUEStionable:ENABle.....	127
STATus:QUEStionable:NTRansition.....	127
STATus:QUEStionable:POWer:CONDition?	126
STATus:QUEStionable:POWer:ENABle.....	127
STATus:QUEStionable:POWer:NTRansition.....	128
STATus:QUEStionable:POWer:PTRansition.....	128
STATus:QUEStionable:POWer[:SUMMary][:EVENT]?	127
STATus:QUEStionable:PTRansition.....	128
STATus:QUEStionable:WINDow:CONDition?	126
STATus:QUEStionable:WINDow:ENABle.....	127
STATus:QUEStionable:WINDow:NTRansition.....	128
STATus:QUEStionable:WINDow:PTRansition.....	128
STATus:QUEStionable:WINDow[:SUMMary][:EVENT]?	127
STATus:QUEStionable[:EVENT]?	127
STATus:QUEue[:NEXT]?	126
SYSTem:COMMunicate:NETWork:CONFigure.....	114
SYSTem:COMMunicate:NETWork:IPADdress.....	115
SYSTem:COMMunicate:NETWork:IPADdress:GATeway.....	115
SYSTem:COMMunicate:NETWork:IPADdress:INFO?	115
SYSTem:COMMunicate:NETWork:IPADdress:MODE.....	115
SYSTem:COMMunicate:NETWork:IPADdress:SUBNet:MASK.....	116
SYSTem:COMMunicate:NETWork:RESet.....	116
SYSTem:COMMunicate:NETWork:REStart.....	116
SYSTem:COMMunicate:NETWork:STATus?	116
SYSTem:COMMunicate:NETWork[:COMMON]:DOMain.....	113
SYSTem:COMMunicate:NETWork[:COMMON]:HOSTname.....	114
SYSTem:DFPPrint:HISTory:COUNT?	119
SYSTem:DFPPrint:HISTory:ENTRy?	119
SYSTem:DFPPrint<Channel>?	119
SYSTem:ERRor:ALL?	123
SYSTem:ERRor:CODE:ALL?	124
SYSTem:ERRor:CODE[:NEXT]?	124
SYSTem:ERRor:COUNT?	124
SYSTem:ERRor[:NEXT]?	124
SYSTem:FWUPdate.....	112

SYSTem:FWUPdate:STATus?	112
SYSTem:HELP:HEADers?	117
SYSTem:HELP:SYNTax:ALL?	117
SYSTem:HELP:SYNTax?	117
SYSTem:INFO:SUPPort?	120
SYSTem:INFO?	120
SYSTem:INITialize	111
SYSTem:LANGuage	117
SYSTem:LED:COLor	121
SYSTem:LED:MODE	122
SYSTem:MINPower:UNIT	123
SYSTem:MINPower?	122
SYSTem:PARAmeters:DELTA?	118
SYSTem:PARAmeters?	118
SYSTem:PRESet	111
SYSTem:REBoot	111
SYSTem:REStart	111
SYSTem:RUTime	122
SYSTem:SECurity:PASSword:SECurity	113
SYSTem:SECurity:PASSword:USER	113
SYSTem:SERRor:LIST:ALL?	125
SYSTem:SERRor:LIST[:NEXT]?	125
SYSTem:SERRor?	125
SYSTem:SUTime	122
SYSTem:TLEVels?	123
SYSTem:TRANsaction:BEgin	118
SYSTem:TRANsaction:END	118
SYSTem:VERSion?	118
SYSTem[:SENSor]:NAME	120
TEST:SENSor?	110
TRIGger:ATRigger:DELay	74
TRIGger:ATRigger:EXECuted?	75
TRIGger:ATRigger[:STATe]	75
TRIGger:COUNt	75
TRIGger:DELay	76
TRIGger:DELay:AUTO	76
TRIGger:DTIME	76
TRIGger:EXTernal<2..2>:IMPedance	76
TRIGger:HOLDoff	77
TRIGger:HYSTeresis	77
TRIGger:IMMEDIATE	77
TRIGger:LEVel	77
TRIGger:LEVel:UNIT	78
TRIGger:SENDER:PORT	78
TRIGger:SENDER:STATe	79
TRIGger:SLOPe	79
TRIGger:SOURce	79
TRIGger:SYNC:PORT	79
TRIGger:SYNC:STATe	80
UNIT:POWER	103

Index

A

Android device	
R&S Power Viewer Mobile	40
Application cards	13
Application notes	13
Auto averaging	82

B

Basic measurement settings	
Basic configuration	82
Brochures	13
Button	
LAN reset	32

C

Calibrating	107
Calibration certificate	13
Checking	15
Cleaning	159
Common command	61
Computer	
Simple USB connection	19
USB sensor hub	20
Using LAN	24
Using USB	19
Configuration	
Averaging	47
Continuous average	45
General	46
Sensor	46
System	50
Trigger	48
Connecting	
Base unit	22
Host	18
RF	16
Supported R&S instrument	22
To a computer	19, 24
Connector	
Host interface	32
LAN	32
Overview	30
RF	30
Trigger I/O	32
Continuous average	
Parameters	45
Continuous average measurement	80
Buffered measurement	129
Controlling host	18
R&S NRX	23
Correction	
Duty cycle	87
I-gamma	92
Offset	88
Remote control	87
S-gamma	90
S-parameter	89
Customer support	156

D

Data	
Accessing	151
Handling	151
Retrieving	151
Device status register	137
Diagnostics	
Selftest	153
Disconnecting	
Host interface	18
RF	17
Disposal	159
Documentation overview	12
Download	
R&S NRP-Toolkit	34
Dropout time	
Trigger	69
DUT	
Connecting	16
Disconnecting	16
Duty cycle	87

E

Electromagnetic interference (EMI)	16
Electrostatic discharge (ESD)	16
Enable register	142
Error	
Querying	123
Error messages	152
ESE	142
ESR	142
Ethernet interface	
Remote control	134

F

Firmware	
Update	111
Firmware update	36, 54
Firmware Update	54
Problems	155
Remote control	58
RSU file	54
SCP	57
SFTP	57
Troubleshooting	56
Web user interface	56
Firmware Update	54
Frequency	86

G

Getting started	12
Graphical user interface	
See web user interface	41

H

HiSLIP	135
Hold-off time	
Trigger	70
Hostname	28

I

I-gamma	92
Initialize	111
Installation	
Firmware	54
Instrument security procedures	12
Intended use	9
Interface	
Overview	30
IP address	29

K

Key features	13
--------------------	----

L

Labels	10
LAN connection	
Configuring	36
Hostname	28
IP address	29
PoE Ethernet switch	24
Problems	156
Setup	24, 27
LAN interface	
Remote control	134
LAN reset button	32
LED	
Network status	33
Power status	32
Status	31

M

Maintenance	159
Cleaning	159
Measurement	
Continuous average	80
Ending	66
Level	122
Limit	122
Preparing	65
Starting	66
Measurement control	66
Continuous average mode	71
Trigger	68
Measurement mode	45
Configuring	80
Continuous average	45
Remote control	66
Measurement results	
Continuous average	105
Controlling	70
Remote control	105
Mobile measurements	40

N

Network	
Settings	113
Network status LED	33
Non-operational data	151

O

Offset	88
Open-source acknowledgment (OSA)	13
Operating concepts	34
App for Android devices	40
R&S NRP-Toolkit	34
R&S NRPV	39
R&S NRX	38
R&S Power Viewer	39
Remote control	38
Web user interface	37
Operating conditions	15
Operation status registers	143
Operational data	151

P

Parameter	
Averaging	47
Common	43
Continuous average	45
General	46
Sensor	46
System	50
Trigger	48
Password	
Changing	112
Power status LED	32
Power supply	17
Preparing for use	15
Preset	111
Programming example	129
Buffered measurement	129
Simplest measurement	129
Protocol	
NRP legacy	133
USBTCM	132

Q

Questionable status registers	139
-------------------------------------	-----

R

R&S NRP-Toolkit	34
Components for Windows-based systems	35
Firmware update	36
Installation under Windows	35
Network configuration	36
S-parameter update	36
S2P wizard	36
SDK	36
System requirements	34
Terminal	37
Uncertainty calculator	36
Version display	36
Versions	34
R&S NRP-Z5	20
R&S NRPV	39
R&S NRX	38
Setup	23
R&S Power Viewer	39
R&S Power Viewer Mobile	40
Reboot	111
Reference source	
Remote control	65

Regulatory information	9
Release notes	13
Remote control	
Basic measurement settings	82
Basics	132
Common commands	61
Continuous average measurement	80
Conventions	60
Ending measurement	66
Ethernet interface	134
Interfaces	132
LAN interface	134
Measurement mode	80
Preparing for measurement	65
Protocols	132
Results	103
Starting measurement	66
Trigger configuration	74
USB interface	132
VISA resource strings	134
Resource string	
HiSLIP	135
Socket	135
VISA	134
VXI-11	135
Restart	111
Results	
Configuring	103
Format	104
Retrieving	105
Unit	103
RF connector	16, 30
RSU file	54

S

S-gamma	90
S-parameter correction	93
Remote control	89
S-Parameters program	93
Configuration	97
S2P measurement data files	101
Uncertainty data files	102
User interface	94
Safety information	9, 15
Safety instructions	9, 12
SCP	57
SDK	36
Security	
Sensor	112
Security procedures	12
Self-test	
Remote control	110
Selftest	153
Sensor	
Information	119
Serial number	10
Setting	
See parameter	42
Settings	
Remote	117
Setup	
LAN connection	24
R&S NRX	23
USB connection	19
SFTP	57
Socket	135

Software update	
See firmware	111
Sources	
Trigger	68
Specifications	13
Standard event status register	142
Status	
Display	121
Update	121
Status information	152
Status LED	31
Status register	125
CONDition part	126
Device status register	137
ENABLE part	127
Enable register	142
EVENT part	127
General commands	126
Hierarchy	136
NTRansition part	127
Operation calibrating status register	144
Operation lower limit fail status register	148
Operation measuring status register	145
Operation sense status register	147
Operation status register	143
Operation trigger status register	146
Operation upper limit fail status register	149
PTRansition part	128
Questionable calibration status register	141
Questionable power status register	140
Questionable status register	139
Standard event status register	142
Storage	159
System configuration	110

T

Target audience	9
Termination control	70
Test setup	16
Transporting	158
Trigger	68
Configuring	74
Dropout time	69
Event	68
Hold-off time	70
Sources	68
States	68
Trigger I/O connector	32
Troubleshooting	152
Error messages	152
Firmware update	155
LAN connection problems	156
Selftest	153
Status information	152

U

Unit	42
Units	61
Unpacking	15
Update file	54
USB connection	19
Setup	19
USB interface	
Remote control	132
USB sensor hub	20

USBTMC protocol 132
User manual 12

V

VISA 134
VXI-11 135

W

Warning message 11
Web user interface 37, 41
 Main dialog 41
 See web user interface 41
White papers 13

Z

Zero configuration networking 27
Zeroing 107