

Satellite Navigation

R&S[®]SMW-K44/-K66/-K94/-K97/-
K98/-K106/-K107/-K108/-K109/-
K122/-K123/-K128/-K129/-K132/-
K134/-K135/-K136/-K137/-K138/-
K139

User Manual



1178637902
Version 17

ROHDE & SCHWARZ
Make ideas real



This document describes the following options:

- R&S®SMW-B9F Wideband Baseband High Signal Dynamics (1434.7808.xx)
- R&S®SMW-K44 GPS (1413.3832.xx)
- R&S®SMW-K66 Galileo (1413.3839.xx)
- R&S®SMW-K94 GLONASS (1414.1485.xx)
- R&S®SMW-K97 NavIC (1414.6258.xx)
- R&S®SMW-K98 Modernized GPS (1414.1533.xx)
- R&S®SMW-K106 SBAS/QZSS (1414.2923.xx)
- R&S®SMW-K107 BeiDou (1414.1585.xx)
- R&S®SMW-K108 Real world simulation (1414.2975.xx)
- R&S®SMW-K109 Real-time interfaces (HIL) (1414.3013.xx)
- R&S®SMW-K122 Real-time kinematics virtual reference station (1414.6993.xx)
- R&S®SMW-K123 Modernized GLONASS (1413.3310.xx)
- R&S®SMW-K128 P(Y)-/M-/PRS-Noise (1413.3361.xx)
- R&S®SMW-K129 Matched-spectrum GNSS interference test (1434.8410.xx)
- R&S®SMW-K132 Modernized BeiDou (1414.6606.xx)
- R&S®SMW-K134 Upgrade to dual-frequency (1414.6770.xx)
- R&S®SMW-K135 Upgrade to triple-frequency (1414.6793.xx)
- R&S®SMW-K136 Add 6 GNSS channels (1414.6812.xx)
- R&S®SMW-K137 Add 12 GNSS channels (1414.6835.xx)
- R&S®SMW-K138 Add 24 GNSS channels (1414.6858.xx)
- R&S®SMW-K139 Add 48 GNSS channels (1414.6935.xx)

This manual describes firmware version FW 5.30.175.xx and later of the R&S®SMW200A.

© 2024 Rohde & Schwarz

Muehldorfstr. 15, 81671 Muenchen, Germany

Phone: +49 89 41 29 - 0

Email: info@rohde-schwarz.com

Internet: www.rohde-schwarz.com

Subject to change – data without tolerance limits is not binding.

R&S® is a registered trademark of Rohde & Schwarz GmbH & Co. KG.

All other trademarks are the properties of their respective owners.

1178.6379.02 | Version 17 | Satellite Navigation

Throughout this document, R&S® is indicated as R&S.

Contents

1	Welcome to the GNSS options	11
1.1	Key features	11
1.2	Accessing the GNSS dialog	13
1.3	What's new	13
1.4	Documentation overview	13
1.4.1	Getting started manual	14
1.4.2	User manuals and help	14
1.4.3	Tutorials	14
1.4.4	Service manual	14
1.4.5	Instrument security procedures	14
1.4.6	Printed safety instructions	15
1.4.7	Specifications and product brochures	15
1.4.8	Calibration certificate	15
1.4.9	Release notes and open source acknowledgment	15
1.4.10	Application notes, application cards, white papers, etc.	15
1.4.11	Videos	15
1.5	Scope	16
1.6	Notes on screenshots	16
2	About the GNSS options	17
2.1	Required options	17
2.2	GNSS overview	19
2.3	SBAS overview	24
2.4	GNSS components overview	25
2.5	How are the GNSS components simulated?	26
3	Getting started	28
3.1	Trying out the GNSS simulator	28
3.2	General settings	32
3.3	Simulation monitor	36
4	Simulation time	46
4.1	Time settings	46

5 Receiver type and position.....	52
5.1 General receiver settings.....	52
5.2 Static receiver.....	54
5.3 Moving receiver.....	59
5.3.1 Configuring a moving receiver.....	59
5.3.2 Receiver position settings.....	61
5.3.3 Motion and attitude configuration and settings.....	64
6 Satellite constellation.....	68
6.1 Systems and signals settings.....	69
6.2 Satellites settings.....	73
6.3 Space vehicle selection configuration.....	77
7 Space vehicle configuration.....	82
7.1 Power settings.....	83
7.2 Modulation control settings.....	88
7.3 Simulated orbit and orbit perturbation settings.....	93
7.4 Simulated clock settings.....	102
8 Real-world environment.....	106
8.1 Spinning and attitude simulation.....	107
8.2 Antenna pattern and body mask.....	108
8.3 Supported environment models.....	110
8.4 Supported multipath models.....	113
8.5 Simulating real-world effects.....	114
8.5.1 Simulating antenna patterns and body masks.....	114
8.5.2 Creating multipath environment scenarios.....	122
8.5.3 Creating obscured environment scenarios.....	124
8.6 Antenna and body mask settings.....	125
8.6.1 Antenna configuration settings.....	126
8.6.2 Edit body mask and antenna pattern settings.....	129
8.7 Environment configuration settings.....	132
8.7.1 Environment model and configuration.....	133
8.7.2 Vertical obstacles.....	134
8.7.3 Roadside planes.....	138

8.7.4	Full obscuration.....	143
8.7.5	Ground/sea reflection.....	146
8.7.6	Static multipath.....	148
9	Real-time kinematics.....	152
9.1	Required options.....	153
9.2	RTK configuration.....	154
9.3	RTK protocol configuration.....	156
9.4	RTK position configuration.....	157
9.5	RTK antenna configuration.....	160
10	Generating Galileo OSNMA signals.....	164
10.1	About OSNMA.....	164
10.1.1	About Galileo OSNMA real-time signals.....	165
10.1.2	About Galileo OSNMA test vectors.....	165
10.2	Generating Galileo OSNMA real-time signals.....	166
10.2.1	Test setup.....	166
10.2.2	Configuring the R&S SMW200A.....	167
10.2.3	Configuring the GNSS receiver.....	168
10.2.4	OSNMA real-time configuration and settings.....	171
10.3	Generating Galileo OSNMA test vector signals.....	178
10.3.1	Test setup.....	178
10.3.2	Configuring the R&S SMW200A.....	178
10.3.3	Configuring the GNSS receiver.....	180
10.3.4	Related settings.....	180
11	Tracking mode.....	181
11.1	Signal dynamics settings.....	181
11.2	Related settings.....	185
12	Matched-spectrum GNSS interferer.....	187
12.1	Required options.....	187
12.2	Related settings.....	188
13	Perturbations and errors simulation.....	192
13.1	About noise and CW interferer.....	192
13.2	Noise and CW interferer settings.....	192

13.3	About error sources.....	198
13.3.1	About the atmospheric effects.....	199
13.3.2	About orbit and orbit perturbation parameters and errors.....	200
13.3.3	About clock and time conversion parameters and errors.....	201
13.3.4	Simulating errors.....	202
13.4	Atmospheric effects and ionospheric errors settings.....	202
13.5	Pseudorange errors settings.....	212
13.6	Orbit and orbit perturbation errors settings.....	215
13.7	Clock errors settings.....	223
13.8	Time conversion errors settings.....	227
13.9	System errors settings.....	232
14	SBAS corrections.....	238
14.1	About SBAS.....	238
14.2	About SBAS corrections.....	240
14.3	How to generate SBAS corrections.....	241
14.4	SBAS settings.....	243
14.4.1	SBAS satellites settings.....	244
14.4.2	GEO ranging information.....	245
14.4.3	Differential corrections.....	250
14.4.4	Additional SBAS system parameters.....	261
15	Advanced GNSS scenarios.....	267
15.1	How to set up advanced GNSS scenarios.....	268
15.1.1	How to enable GNSS advanced mode.....	268
15.1.2	How to set up multifrequency scenarios.....	270
15.1.3	How to set up multi-vehicle scenarios.....	275
15.1.4	How to set up multi-antenna scenarios.....	276
15.1.5	How to configure GNSS streams.....	278
15.2	Advanced GNSS settings.....	282
15.2.1	Related settings.....	282
15.2.2	Output streams settings.....	285
16	Data logging.....	289
16.1	Data logging general settings.....	291

16.2	Configure logging settings.....	294
17	Assistance data generation.....	299
17.1	Generating assistance data.....	299
17.2	Assistance data generation settings.....	300
17.2.1	General settings.....	301
17.2.2	Space vehicle settings.....	305
17.2.3	Time of assistance data settings.....	305
18	Loading constellation and navigation message data.....	308
18.1	Import constellation settings.....	310
18.2	Import SBAS settings.....	312
19	Hardware in the loop (HIL).....	314
19.1	Tips for best results.....	315
19.1.1	Synchronization.....	315
19.1.2	System latency.....	316
19.1.3	Latency calibration.....	316
19.1.4	Adding a constant delay to compensate for command jitter.....	318
19.1.5	Interpolation.....	320
19.1.6	Trajectory prediction.....	320
19.2	HIL settings.....	321
19.3	UDP position data.....	327
19.4	SCPI position data.....	328
19.5	Remote-control commands.....	329
20	Signal generation control.....	337
20.1	Trigger settings.....	337
20.2	Marker settings.....	342
20.3	Clock settings.....	346
20.4	Local and global connectors settings.....	347
21	Signal generation tasks with the GNSS options.....	349
21.1	General workflow for signal generation tasks.....	349
21.2	Generating GNSS signals for simple receiver tests.....	351
21.3	Simulating real-world effects.....	351
21.4	Adding noise or CW interferer.....	351

21.5	Loading historical data.....	351
21.6	Generating GNSS advanced mode signals.....	351
22	Remote-control commands.....	353
22.1	General commands.....	356
22.2	System and signal commands.....	361
22.3	Time conversion configuration.....	366
22.4	Receiver positioning configuration commands.....	380
22.5	Antenna pattern and body mask.....	389
22.6	Real-time kinematics (RTK) commands.....	393
22.6.1	RTK general commands.....	395
22.6.2	RTK location commands.....	395
22.6.3	RTK antenna commands.....	399
22.6.4	RTK protocol commands.....	401
22.7	Environment configuration commands.....	402
22.8	Static multipath configuration.....	415
22.9	Atmospheric configuration commands.....	428
22.10	AWGN configuration.....	434
22.11	Satellites constellation.....	438
22.12	Signals and power configuration per satellite.....	448
22.13	Navigation message commands.....	478
22.13.1	Simulated orbit, orbit perturbation and clock commands.....	480
22.13.2	Pseudorange commands.....	491
22.13.3	Orbit, clock, system, time conversion and ionospheric errors.....	500
22.14	Galileo OSNMA commands.....	566
22.15	SBAS corrections.....	574
22.16	Signal dynamics.....	585
22.17	Assistance data commands.....	596
22.18	Monitoring and real-time commands.....	603
22.18.1	Monitoring commands.....	605
22.18.2	Real-time commands.....	612
22.19	Data logging commands.....	624
22.20	Advanced mode commands.....	630
22.21	Trigger commands.....	639

22.22	Marker commands.....	645
22.23	Clock commands.....	649
	Annex.....	650
	A User environment files.....	650
	A.1 Movement or motion files.....	650
A.1.1	Waypoint file format.....	650
A.1.2	Vector trajectory file format.....	653
A.1.3	NMEA files.....	656
A.1.4	Trajectory description files.....	656
A.1.5	Resampling principle.....	660
A.1.6	Calculating the maximum duration of a movement file.....	661
	A.2 Vehicle description files.....	662
	A.3 Antenna pattern and body mask files.....	663
	B RINEX files.....	666
	C NMEA scenarios.....	667
	D QZSS navigation message scheduling.....	669
	E Predefined GNSS scenarios.....	670
E.1	3GPP TS and assisted GNSS.....	670
E.2	Assisted GNSS test scenarios.....	671
E.3	Assisted GNSS 2020 test scenarios.....	676
E.4	Real constellations reference scenarios.....	680
E.5	Galileo OSNMA scenarios.....	680
	F Ionospheric grid file format.....	681
	G Channel budget.....	682
G.1	Hardware resources.....	683
G.2	Instrument setups.....	685
	H List of predefined files.....	688

Glossary: Specifications and references.....690
List of commands..... 692
Index.....739

1 Welcome to the GNSS options

The R&S SMW200A-K44/-K66/-K94/-K97/-K98/-K106/-K107/-K108/-K109/-K122/-K132/-K134/-K135/-K136/-K137/-K138/-K139 are firmware applications that add functionality to generate signals in accordance with GPS, Galileo, GLONASS, NavIC, QZSS and COMPASS/BeiDou navigation systems and SBAS augmentation systems.

This user manual contains a description of the functionality that the application provides, including remote control operation.

All functions not discussed in this manual are the same as in the base unit and are described in the R&S SMW200A user manual. The latest version is available at:

www.rohde-schwarz.com/manual/SMW200A

Installation

You can find detailed installation instructions in the delivery of the option or in the R&S SMW200A service manual.

• Key features	11
• Accessing the GNSS dialog	13
• What's new	13
• Documentation overview	13
• Scope	16
• Notes on screenshots	16

1.1 Key features

The global navigation satellite system (GNSS) solution for the R&S SMW200A is suitable for R&D lab tests or production tests. Supported are all possible scenarios, from simple setups with individual satellites all the way to flexible scenarios generated in real time.

Real-time scenarios offer simulation of up to several hundred satellites for navigation systems GPS, Galileo, GLONASS, BeiDou, NavIC and QZSS depending on the installed options.

Key features

The GNSS options key features are:

- Support of multiple GNSS and regional navigation satellite systems (RNSS) and signals including mixed constellations ([Table 1-1](#))
- Support of satellite-based augmentation systems (SBAS) and signals including mixed constellations ([Table 1-2](#))
- Configuring the state of a particular signal component individually
- Real-time simulation of mixed constellations and unlimited simulation time
- Flexible scenario generation including moving scenarios, dynamic power control and atmospheric modeling

- Simulation of real-time kinematics (RTK) virtual reference stations
- Configuration of realistic user environments, including obscuration and multipath, antenna characteristics and vehicle attitude
- Navigation test mode for satellite constellation simulation, position fixing and time to first fix (TTFF) testing
- Tracking test mode for signal acquisition and tracking tests
- Simulation of orbit perturbations and pseudorange errors
- Support of ranging, correction and integrity services for SBAS
- Configuration suitable for basic receiver testing using signals with zero, constant or varying Doppler profiles
- Common configuration of advanced GNSS scenarios
- Support of assisted GNSS test scenarios, including generation of assistance data for GPS, Galileo, GLONASS and BeiDou
- Logging of user motion and satellite-related parameters
- Real-time external trajectory feed for hardware in the loop (HIL) applications
- High signal dynamics, simulation of spinning vehicles to support aerospace and defense applications

Table 1-1: Supported GNSS/RNSS, frequency bands and signals

GNSS/RNSS	L1 band	L2 band	L5 band
GPS	C/A, P, L1C, P(Y)-Noise, M-Noise	C/A, P, L2C, P(Y)-Noise, M-Noise	L5
Galileo	E1 OS, E1 PRS-Noise	E6, E6 PRS-Noise	E5a, E5b
GLONASS	C/A, CDMA L1	C/A, CDMA L2	CDMA L3
BeiDou	B1I, B1C	B3I	B2I, B2a, B2b
QZSS	C/A, L1C	L2C	L5
NavIC	-	-	SPS

For detailed information, see [Chapter 2.2, "GNSS overview"](#), on page 19.

Table 1-2: Supported SBAS, frequency bands and signals

SBAS	L1 band	L2 band	L5 band
EGNOS	C/A	-	Exp L5
WAAS	C/A	-	Exp L5
MSAS	C/A	-	-
GAGAN	C/A	-	-

For detailed information, see [Table 2-11](#).

1.2 Accessing the GNSS dialog

To open the dialog with GNSS settings

- ▶ In the block diagram of the R&S SMW200A, select "Baseband" > "GNSS".

A dialog box opens that displays the provided general settings.

The signal generation is not started immediately. To start signal generation with the default settings, select "State" > "On".

1.3 What's new

This manual describes firmware version FW 5.30.175.xx and later of the R&S®SMW200A.

Compared to the previous version, it provides the new features listed below:

- R&S SMW-K129 matched-spectrum GNSS interference test, see [Chapter 12, "Matched-spectrum GNSS interferer"](#), on page 187.
- Generating real-time Galileo open service navigation message authentication (OSNMA) signals, see [Chapter 10.1.1, "About Galileo OSNMA real-time signals"](#), on page 165 and [Chapter 10.2, "Generating Galileo OSNMA real-time signals"](#), on page 166.
- Galileo OSNMA test vector scenarios configuration 1 and configuration 2 added, see [Table 10-1](#).
- Assistance data generation instructions added and settings simplified, see [Chapter 17.1, "Generating assistance data"](#), on page 299 and [Chapter 17.2, "Assistance data generation settings"](#), on page 300.
- New file format with extension *.tle for waypoint files of a moving GNSS receivers, see ["Waypoint File"](#) on page 62.
- Editorial changes

1.4 Documentation overview

This section provides an overview of the R&S SMW200A user documentation. Unless specified otherwise, you find the documents at:

www.rohde-schwarz.com/manual/smw200a

1.4.1 Getting started manual

Introduces the R&S SMW200A and describes how to set up and start working with the product. Includes basic operations, typical measurement examples, and general information, e.g. safety instructions, etc. A printed version is delivered with the instrument.

1.4.2 User manuals and help

Separate manuals for the base unit and the software options are provided for download:

- **Base unit manual**
Contains the description of all instrument modes and functions. It also provides an introduction to remote control, a complete description of the remote control commands with programming examples, and information on maintenance, instrument interfaces and error messages. Includes the contents of the getting started manual.
- **Software option manual**
Contains the description of the specific functions of an option. Basic information on operating the R&S SMW200A is not included.

The contents of the user manuals are available as help in the R&S SMW200A. The help offers quick, context-sensitive access to the complete information for the base unit and the software options.

All user manuals are also available for download or for immediate display on the internet.

1.4.3 Tutorials

The R&S SMW200A provides interactive examples and demonstrations on operating the instrument in the form of tutorials. A set of tutorials is available directly on the instrument.

1.4.4 Service manual

Describes the performance test for checking compliance with rated specifications, firmware update, troubleshooting, adjustments, installing options and maintenance.

The service manual is available for registered users on the global Rohde & Schwarz information system (GLORIS):

<https://gloris.rohde-schwarz.com>

1.4.5 Instrument security procedures

Deals with security issues when working with the R&S SMW200A in secure areas. It is available for download on the internet.

1.4.6 Printed safety instructions

Provides safety information in many languages. The printed document is delivered with the product.

1.4.7 Specifications and product brochures

The specifications document, also known as the data sheet, contains the technical specifications of the R&S SMW200A. It also lists the firmware applications and their order numbers, and optional accessories.

The brochure provides an overview of the instrument and deals with the specific characteristics.

See www.rohde-schwarz.com/brochure-datasheet/smw200a

1.4.8 Calibration certificate

The document is available on <https://gloris.rohde-schwarz.com/calcert>. You need the device ID of your instrument, which you can find on a label on the rear panel.

1.4.9 Release notes and open source acknowledgment

The release notes list new features, improvements and known issues of the current software version, and describe the software installation.

The software uses several valuable open source software packages. An open source acknowledgment document provides verbatim license texts of the used open source software.

www.rohde-schwarz.com/firmware/smw200a

1.4.10 Application notes, application cards, white papers, etc.

These documents deal with special applications or background information on particular topics.

www.rohde-schwarz.com/application/smw200a

For some application sheets, see also:

www.rohde-schwarz.com/manual/smw200a

1.4.11 Videos

Find various videos on Rohde & Schwarz products and test and measurement topics on YouTube: <https://www.youtube.com/@RohdeundSchwarz>



On the menu bar, search for your product to find related videos.



Figure 1-1: Product search on YouTube

1.5 Scope



Tasks (in manual or remote operation) that are also performed in the base unit in the same way are not described here.

In particular, it includes:

- Managing settings and data lists, like saving and loading settings, creating and accessing data lists, or accessing files in a particular directory.
- Information on regular trigger, marker and clock signals and filter settings, if appropriate.
- General instrument configuration, such as checking the system configuration, configuring networks and remote operation
- Using the common status registers

For a description of such tasks, see the R&S SMW200A user manual.

1.6 Notes on screenshots

When describing the functions of the product, we use sample screenshots. These screenshots are meant to illustrate as many as possible of the provided functions and possible interdependencies between parameters. The shown values may not represent realistic usage scenarios.

The screenshots usually show a fully equipped product, that is: with all options installed. Thus, some functions shown in the screenshots may not be available in your particular product configuration.

2 About the GNSS options

Global navigation satellite system (GNSS) employs the radio signals of several navigation standards, like GPS, Galileo, GLONASS and BeiDou and NavIC. For several years, GPS used to be the only standard available for civilian navigation through its C/A civilian code.

Nowadays, the GNSS signals and systems are undergoing fast development, some systems are getting modernized and some are new. In the foreseeable future, several more GNSS satellites utilizing more signals and new frequencies are available.

The GNSS implementation in the R&S SMW200A enables you to generate composite signals of GNSS satellites, depending on the installed options. Signal generation is performed in real time and thus not limited to a certain time period.

The following chapters provide background information on required options, basic terms and principles in the context of GNSS signal generation. For detailed information on the GNSS standards, see the corresponding specifications.

2.1 Required options

The basic equipment layout for generating GNSS signals includes:

- Standard or wideband baseband generator (R&S SMW-B10/-B9/-B9F)
- Baseband main module (R&S SMW-B13/-B13T) or wideband baseband main module (R&S SMW-B13XT)
- Frequency option (e.g. R&S SMW-B1003)
- At least one basic or modernized GNSS option, per signal path, see [Table 2-1](#). The modernized GNSS options do not require a basic GNSS option.
- Optional enhanced simulation capability options, see [Table 2-2](#).
 - R&S SMW-B9/-B9F: Advanced GNSS, install one simulation capability option only
 - R&S SMW-B10: Standard GNSS, install one simulation capability option per signal path
- Optional enhanced simulation capacity options, see [Table 2-3](#).

Table 2-1: GNSS system options

Option	Designation	Remark
R&S SMW-K44	GPS	C/A and P signals in the L1 and L2 bands
R&S SMW-K66	Galileo	E1 OS, E6, E5a and E5b signals in L1, L2 and L5 bands
R&S SMW-K94	GLONASS	C/A signal in the L1 and L2 bands
R&S SMW-K97	NavIC/IRNSS	SPS signal in L5 band
R&S SMW-K98	Modernized GPS	L1C, L2C and L5 signals in L1, L2 and L5 bands

Required options

Option	Designation	Remark
R&S SMW-K107	BeiDou/COMPASS	B1I and B2I signals in the L1 and L5 bands Q-component AS signals are not supported, see also Table 2-8 .
R&S SMW-K123	Modernized GLONASS	Requires R&S SMW-B9/B9F. CDMA L1, L2 and L3 signals in L1, L2 and L5 bands
R&S SMW-K128	P(Y)-/M-/PRS-Noise	Requires R&S SMW-B9/B9F. GPS P(Y)-Noise and M-Noise signals in L1 and L2 bands Galileo E1 PRS-Noise and E6 PRS-Noise signals in L1 and L2 bands
R&S SMW-K132	Modernized BeiDou	B1C, B3I, B2a, and B2b_I signals in L1, L2 and L5 bands Q-component AS signals including B2b_Q are not supported, see also Table 2-8 .

Table 2-2: GNSS simulation capability options

Option	Designation	Remark
R&S SMW-K106	SBAS/QZSS	Requires R&S SMW-K44. Augmentation system option using satellite based and regional navigation signals.
R&S SMW-K108	Real world simulation	Simulates real-world environments: Signal obscurations, echoed and multipath effects, receiver antenna patterns and body masks.
R&S SMW-K109	Real-time interfaces	Emulates a realistic environment of the DUT in real time via the Hardware in the Loop test mode.
R&S SMW-K122	Real-time kinematics (RTK)	Requires R&S SMW-B9 or B9F. Simulates real-time kinematics for one RTK base station and one GNSS receiver.
R&S SMW-K129	Matched-spectrum GNSS interference test	Requires R&S SMW-B9 or B9F. Simulates GNSS interference signals with correct PRN sequences and modulation for all GNSS channels and provides a realistic satellite constellation. Navigation message data generation is disabled.

Option R&S SMW-K120 Advanced GNSS is no longer required, since advanced GNSS operation requires R&S SMW-B9 or B9F.

Table 2-3: GNSS simulation capacity options

Option	Designation	Remark
R&S SMW-K134	Dual-frequency GNSS	Requires R&S SMW-B9. Simulation of 2 RF band signals
R&S SMW-K135	Triple-frequency GNSS	Requires R&S SMW-B9 and R&S SMW-K134. Simulation of 3 RF band signals
R&S SMW-K136	Add 6 GNSS channels	Requires R&S SMW-B9. Installable up to 8 times

Option	Designation	Remark
R&S SMW-K137	Add 12 GNSS channels	Requires R&S SMW-B9. Installable up to 8 times
R&S SMW-K138	Add 24 GNSS channels	Requires R&S SMW-B9. Installable up to 8 times
R&S SMW-K139	Add 48 GNSS channels	Requires R&S SMW-B9. Installable up to 8 times

There is a limitation on the maximum number of satellite signals or GNSS channels that can be simulated simultaneously. For more information, see [Chapter G, "Channel budget"](#), on page 682.

To find out installed GNSS options

- ▶ Select "System Config" > "Setup" > "Instrument Assembly" > "Versions / Options" > "Software Options".

The column "Licenses" lists the number of installed options.

To play back GNSS waveforms

You can generate signals via playback of waveform files at the signal generator. To create the waveform file with R&S WinIQSIM2, you do not need a specific option.

To play back the waveform file at the signal generator, you have two options:

- Install the R&S WinIQSIM2 option of the digital standard, for example, R&S SMW-K255 for playing LTE waveforms.
- If supported, install the real-time option of the digital standard, for example, R&S SMW-K55 for playing LTE waveforms.

For more information, refer to the specifications document.

2.2 GNSS overview

This section provides an overview on the GNSS including the following:

- Power spectral density, frequency bands and center frequencies f_{center}
- Characteristics of the satellite constellation
- Signal plan for each GNSS

The number of deployed satellites increases constantly. For the current deployment status, see the official information of the GNSS providers.

The GNSS simulation capacity depends on installed options and the visibility state of the individual satellite. For the number of satellites that can be present in the satellite constellation, see [Table 6-1](#).

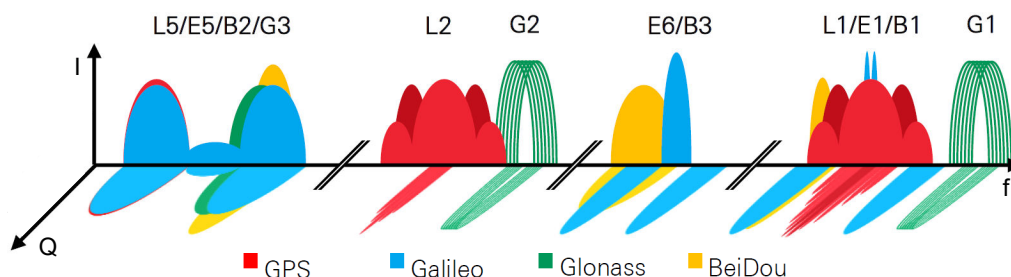

Figure 2-1: Power spectral density and center frequencies of most important GNSS signals

- Red = GPS L1, L2 and L5 signals, details in [GPS signal plan](#)
- Blue = Galileo E1, E5 and E6 signals, details in [Galileo signal plan](#)
- Green = GLONASS G1(L1), G2(L2) and G3(L5) signals, details in [GLONASS FDMA signal plan](#)
- Yellow = BeiDou B1, B2 and B3 signals, details in [BeiDou signal plan](#)

GPS

The Global Positioning System (GPS) consists of several satellites circling the earth in low orbits. The satellites transmit permanently information that can be used by the receivers to calculate their current position (ephemeris) and about the orbits of all satellites (almanac). The 3D position of a receiver on the earth can be determined by carrying out delay measurements of at least four signals emitted by different satellites.

Being transmitted on a single carrier frequency, the signals of the individual satellites can be distinguished by correlation (gold) codes. These ranging codes are used as spreading codes for the navigation message which is transmitted at a rate of 50 bauds. The C/A codes provide standard positioning service (SPS). The P codes provide precise positioning service (PPS).

For interface control documents (ICD), see [GPS ICD](#).

Table 2-4: GPS signal plan

Signal	C/A	P, P(Y)-Noise ¹⁾	L1C	L2C	M-Noise ¹⁾	L5
Freq. band	L1 L2	L1 L2	L1	L2	L1 L2	L5
f _{center} , MHz	1575.42 1227.6	1575.42 1227.6	1575.42	1227.6	1575.42 1227.6	1176.45
Modulation	BPSK(1)	-	TMBOC (6,1,1/11)	BPSK(1)	-	QPSK(10)

¹⁾ The GPS signals P(Y)-Noise and M-Noise are for experimental use only. These signals contain arbitrary noise. Use them for spectral interferer testing. For example, to generate a C/A signal and an interfering P(Y)-Noise signal on the same center frequency. These noise signals are not useful for position fix calculation and do not comply with any ICD specification.

Galileo

Galileo is the European global navigation satellite system that provides global positioning service under civilian control. It is planned to be inter-operable with GPS and GLO-NASS and other global satellite navigation systems.

The fully deployed Galileo system consists of operational and spare satellites. Three independent CDMA signals, named E5, E6 and E1, are permanently transmitted by all Galileo satellites. The E5 signal is further subdivided into two signals denoted E5a and E5b (see [Figure 2-1](#)). The Galileo system provides open service (OS), public regulated service (PRS) to authorized, commercial service (CS) and search and rescue (SAR) service.

For interface control documents (ICD), see [Galileo ICD](#).

Table 2-5: Galileo signal plan

Signal	E1 OS	E1 PRS-Noise ¹⁾	E5a	E5b	E6	E6 PRS-Noise ¹⁾
Freq. band	E1 L1 (GPS)	E1 L1 (GPS)	E5 L5 (GPS)	E5 L5 (GPS)	E6 L2 (GPS)	E6 L2 (GPS)
f_{center} , MHz	1575.42	1575.42	1176.45	1207.14	1278.75	1278.75
Modulation	CBOC (6,1,1/11)	-	AltBOC (15,10)	AltBOC (15,10)	BPSK(5)	-

¹⁾ The Galileo signals E1 PRS-Noise and E6 PRS-Noise are for experimental use only. These signals contain arbitrary noise. Use them for spectral interferer testing. For example, to generate a E1 OS signal and an interfering E1 PRS-Noise signal on the same center frequency. These noise signals are not useful position fix calculation and do not comply with any ICD specification.

GLONASS

GLONASS is the Russian global navigation satellite system that uses 24 modernized GLONASS satellites touring the globe.

Together with GPS, more GNSS satellites are provided, which improves the availability and therefore the navigation performance in high-urban areas.

For interface control documents (ICD), see [GLONASS ICD](#).

Table 2-6: GLONASS FDMA signal plan

Signal	C/A	C/A	P ¹⁾	P ¹⁾
Freq. band	L1 (G1)	L2 (G2)	L1 (G1)	L2 (G2)
f_{center} , MHz	$1602 \pm k \cdot 0.5625^2)$	$1246 \pm k \cdot 0.5625^2)$	$1602 \pm k \cdot 0.5625^2)$	$1246 \pm k \cdot 0.5625^2)$
Modulation	BPSK(0.5)	BPSK(0.5)	BPSK(5)	BPSK(5)

¹⁾ L1 and L2 P code signals are not supported in the GNSS firmware.

²⁾ k is the frequency number (FDMA) with $-7 \leq k \leq 13$.

Table 2-7: GLONASS CDMA signal plan

Signal	CDMA L1 ¹⁾	CDMA L2 ¹⁾	CDMA L3
Freq. band	L1	L2	L5
f_{center} , MHz	1600.995	1248.06	1202.025
Modulation	TDM	TDM	QPSK

¹⁾ The modernized GLONASS signals CDMA L1 and CDMA L2 are for experimental use only. Any compliance with GLONASS ICD CDMA open service navigation signal in L1 frequency band or GLONASS ICD CDMA open service navigation signal in L2 frequency band is not guaranteed.

BeiDou

The fully deployed BeiDou navigation satellite system (BDS) is a Chinese satellite navigation system. This navigation system is also referred as BeiDou-2.

The BDS is a global satellite navigation system with a constellation of satellites (COMPASS satellites) to cover the globe. The constellation includes geostationary orbit satellites (GEO) and non-geostationary satellites. The non-geostationary satellites comprise medium earth orbit satellites (MEO) and inclined geosynchronous orbit (IGSO).

The BDS uses frequencies allocated in the B1, B2 and B3 bands. The in phase components (I-components) of the signals provide open service (OS), the quadrature phase components (Q-components) of the signals provide authorized service (AS). For an overview of supported OS signals, see [Table 2-8](#). Q-component AS signals B1Q, B2Q, including B2b_Q, and B3Q are not supported in the GNSS firmware.

For interface control documents (ICD), see [BeiDou ICD](#).

Table 2-8: BeiDou signal plan

Signal	B1C	B1I	B2a	B2b ¹⁾	B2I	B3I
Freq. band	B1 L1 (GPS)	B1 L1 (GPS)	B2 L5 (GPS)	B2 L5 (GPS)	B2 L5 (GPS)	B3 L2 (GPS)
f_{center} , MHz	1575.42	1561.098	1176.45	1207.14	1207.14	1268.52
Modulation	BOC(1,1) QMBOC(6, 1, 4/33)	BPSK(2)	BPSK(10) BPSK(10)	BPSK(10)	BPSK(2)	BPSK(10)

¹⁾ BeiDou B2b_I I-component of the B2b open service signal for space vehicles PRN 6 to PRN 58.

QZSS

The Quasi-Zenith satellite system (QZSS) is a regional space-based positioning system deployed in 2013.

In its final deployment stage, the QZSS uses a total number of three regional non-geostationary and highly inclined satellites and one geostationary orbit (GEO) satellite. The QZSS does not aim to cover the globe but to increase the availability of GPS in Japan, especially in the larger towns.

The QZSS uses signals that are similar to the GPS public signals. For interface control documents (ICD), see [QZSS ICD](#).

Table 2-9: QZSS signal plan

Service name	C/A	L1C	SAIF ¹⁾	L2CM, L2CL	L5I, L5Q	LEX ¹⁾
Signal	C/A	L1C	-	L2C	L5	-
Freq. band	L1	L1	L1	L2	L5	E6
f_{center} , MHz	1575.42	1575.42	1575.42	1227.6	1176.45	1278.75
Modulation	BPSK(1)	TMBOC (6,1,1/11)	BPSK(1)	BPSK(1)	BPSK(10)	BPSK(5)

¹⁾ QZSS SAIF and E6 LEX signals are not supported in the GNSS firmware.

NavIC

NavIC (Navigation Indian Constellation) is the Indian navigation satellite system, formerly denoted IRNSS (Indian Regional Navigational Satellite System).

NavIC is a regional satellite navigation system with a constellation of satellites to cover an area of 1500 km surrounding India (2016). The constellation includes geostationary orbit (GEO) satellites and inclined geosynchronous orbit (IGSO) satellites.

The NavIC system uses frequencies allocated in the L5 and S bands providing special positioning service (SPS) and precision service (PS).

For interface control documents (ICD), see [NavIC ICD](#).

Table 2-10: NavIC signal plan

Signal	SPS	PS ¹⁾
Freq. band	L5	S
f_{center} , MHz	1176.45	2491.75
Modulation	BPSK(1)	N/A

¹⁾ NavIC PS signal is not supported in the GNSS firmware.

Assisted GNSS (A-GNSS)

Assisted GNSS (A-GNSS) was introduced to different mobile communication standards to reduce the time to first fix (TTFF) of a user equipment (UE) containing a GNSS receiver. The reduction is achieved by transmitting information (assistance data) mainly about the satellites directly from a base station to the UE.

For example, a standalone GPS receiver needs about 30 to 60 seconds for a first fix and up to 12.5 minutes to get all information (almanac).

In A-GNSS "UE-based mode", the base station assists the UE by providing the complete navigation message along with a list of visible satellites and ephemeris data. In addition to this information, the UE gets the location and the current time at the base station. That speeds up both acquisition and navigation processes of the GPS receiver and reduces TTFF to a few seconds.

In A-GNSS "UE assisted mode", the base station is even responsible for the calculation of the UE's exact location. The base station takes over the navigation based on the raw measurements provided by the UE. Since the acquisition assistance data provided by the base station already serves speeding up the acquisition process, the UE only has to track the code and carrier phase.

2.3 SBAS overview

Satellite-based augmentation systems (SBAS) use geostationary satellites (GEO) to broadcast GNSS coarse integrity and wide area correction data (error estimations), and ranging signal to augment the GNSS.

SBAS broadcast augmentation data in the GPS frequency band L1 using the C/A code of GPS. For experimental use, the R&S SMW200A provides modulation of SBAS L1 navigation message data in the GPS L5 band for SBAS systems EGNOS and WAAS. The signal "Exp L5" is a pure copy of L1 data and does not comply with SBAS interface control document (ICD) specifications.

Table 2-11: SBAS signal plan

Signal	C/A	Exp L5
Freq. band	L1	L5
f_{center} , MHz	1575.42	1176.45
Modulation	BPSK(1)	N/A

The SBAS provides data for a maximum of 51 satellites. In the SBAS, the term "pseudo random number" (PRN) is used instead of the term space vehicle (SV). There are 90 PRN numbers reserved for SBAS, where the numbering starts at 120.

Several SBAS systems are still in their development phase, like, for example, the SDCM in Russia Federation, and GAGAN in India.

SBAS systems that are currently in operation augment the US GPS satellite navigation system, so that they are suitable, for example, for civil aviation navigation safety needs. The following SBAS systems are supported by R&S SMW200A:

- **EGNOS**
EGNOS (European geostationary navigation overlay service) EGNOS is the European SBAS system.
- **WAAS**
WAAS (wide area augmentation system) is the SBAS system in United States.
- **MSAS**
MSAS (multi-functional satellite augmentation system) is the SBAS system working in Japan. It uses the multi-functional transport satellites (MTSAT) and supports differential GPS.
- **GAGAN**
GAGAN (GPS aided geo augmented navigation system) is the SBAS implementation by the Indian government.

2.4 GNSS components overview

The GNSS system consists of three main components: the space segment, the ground segment and the user segment.

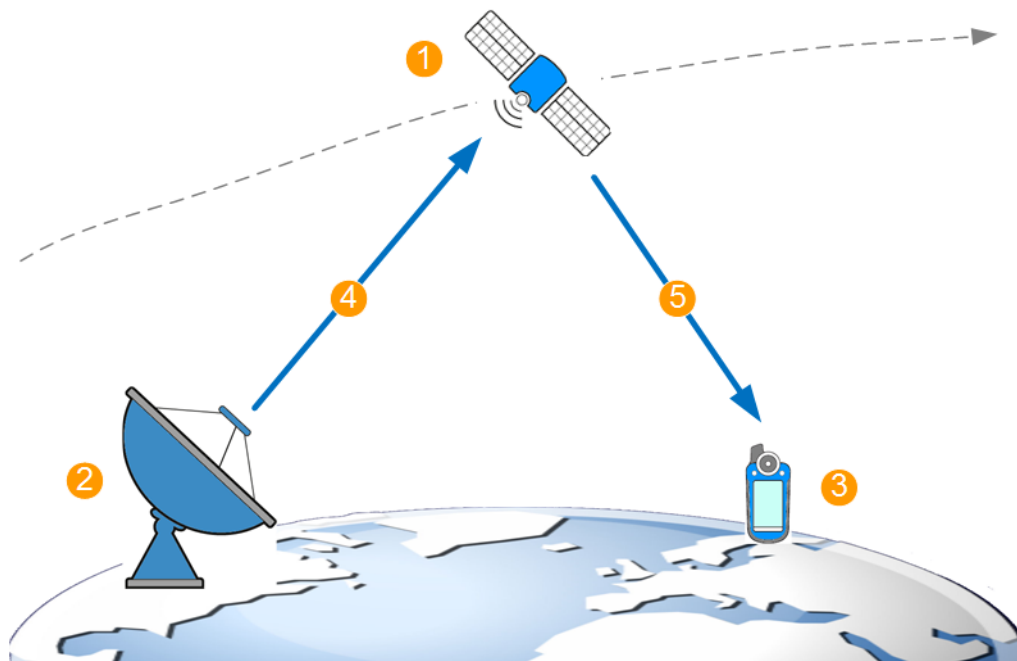

Figure 2-2: GNSS system components (simplified)

- 1 = Space segment or satellites
- 2 = Ground segment or ground stations
- 3 = User segment or receivers
- 4 = Ephemeris (broadcasted satellites orbit and clock)
- 5 = Broadcasted navigation message

Space segment

The space segment consists of the **satellites** that orbit the earth on their individual orbits. Satellites broadcast signals at specific frequency in the L band and spread by predefined codes. For the GPS satellites using L1 frequency band, for instance, the predefined codes are the coarse/acquisition (C/A) or the precision (P) codes.

The transmitted signal carries the **navigation message**, on which each satellite broadcasts its major characteristics, its clock offsets and precise orbit description, where the latter is called **ephemeris**. The navigation message contains also satellites status information, ionospheric and time-related parameters, UTC information and orbit data with reduced accuracy for all other satellites, commonly referred as **almanac**.

Ground segment

The ground segment is a network of **ground stations** whose primary goal is to measure constantly the satellites' location, altitude and velocity, and the satellites signals. The ground stations also estimate the influence of the ionosphere. They calculate the **precise orbit (and orbit perturbation)** parameters and **clock drifts** parameters of

each satellite. This corrected highly accurate information is regularly broadcasted back to the satellites so that their navigation messages can be updated.

User segment

Finally, the **receiver** decodes the navigation message (ephemeris and almanac) broadcasted by the GNSS satellites, obtains information regarding the satellites orbit, clock, health etc. and calculates the satellites coordinates. The receiver also measures the signal propagation time (i.e. the pseudorange) of at least four satellites and estimates its own position.

2.5 How are the GNSS components simulated?

In real life, the true satellite orbit can differ from the orbit information that the satellite broadcasts.

In this implementation, the simulated orbit is the true orbit. Thus, the satellites motion along their orbits, the clock they use and the current distance to each of them are referred to as **simulated orbit, clock and pseudorange**. They are set as retrieved from the constellation data source and can be configured on a per satellite basis.

The navigation message of each of the satellites is per default identical to the simulated one. It is referred to as **broadcasted navigation message**, since it represents the broadcasted satellite's signal, see [Figure 2-2](#). Per default, the broadcasted and the simulated orbit and clock parameters match. Obviously, if the parameters in any of those two groups are changed, a deviation between the sets is simulated.

The receiver is the device under test (**DUT**). In the simulation, the receiver is represented by its position, antenna configuration, environment, etc. The receiver is tested with the GNSS that it would receive in a real-world situation if placed in the specified conditions.

Simulation date, time and location

The R&S SMW200A generates the signal for any simulation date and time, in the past or in the future. The generated signal represents any location, on the earth or in the space, for a static or moving receiver.

You have full control over the satellites' constellation, the satellites signals and the navigation message of each satellite. Repeat measurement scenarios with same preconditions and vary the complexity or replay simulation events from the past.

For details, see:

- [Chapter 4, "Simulation time"](#), on page 46
- [Chapter 5, "Receiver type and position"](#), on page 52
- [Chapter 6, "Satellite constellation"](#), on page 68
- [Chapter 7, "Space vehicle configuration"](#), on page 82

Real-world scenarios through environmental effects

You can also simulate various different environmental conditions, like the effect of the receiver's antenna characteristic, vehicle movement, vehicle body mask, multipath propagation, obstacles or the atmosphere.

For details, see [Chapter 8, "Real-world environment"](#), on page 106.

Ionospheric effects

You can also simulate the effect of the atmospheric (ionospheric and tropospheric) errors on the positioning accuracy.

For details, see ["Tropospheric and ionospheric models"](#) on page 199.

GNSS errors sources

Additional to the real-world and the ionosphere effects, you can simulate signal errors by manipulating the navigation messages of the satellites. Signal errors have a direct impact on the receiver's positioning accuracy.

You can observe the effect of the following common error sources:

- Ephemeris errors: Orbit and orbit perturbation errors
- Satellite clock and time conversion errors
- Pseudorange errors

For details, see [Chapter 13, "Perturbations and errors simulation"](#), on page 192.

Historical constellations and navigation data

You can also replay historical satellite constellations, by loading constellation files and navigation data files for all GNSS systems supported in the GNSS firmware.

For details, see:

- ["File formats"](#) on page 308
- [Chapter 18.1, "Import constellation settings"](#), on page 310

Correction data

You can also correct navigation data by loading SBAS corrections.

For details, see:

- [Chapter 14, "SBAS corrections"](#), on page 238
- [Chapter 18.2, "Import SBAS settings"](#), on page 312

3 Getting started

In its default configuration, the software generates GNSS signal that is sufficient for a receiver to get a position fix. The simulated GNSS depends on the installed options. For example, if R&S SMW200A-K44 is installed, it is GPS C/A signal in the L1 band.

For all GNSS, the simulation starts on 2014-02-19 at 6 am UTC time and the satellite constellation corresponds to a constellation that is visible for a static receiver located in Munich.

To simulate a defined configuration, you can load predefined assistance GNSS scenarios or load a user-defined scenario. The software applies the configuration automatically, you can change related settings afterwards. For example, try out the receiver templates and configure a receiver, moving in a circle in New York.

- [Trying out the GNSS simulator](#)..... 28
- [General settings](#)..... 32
- [Simulation monitor](#)..... 36

3.1 Trying out the GNSS simulator

The following simple examples can help you get familiar with the basic functions of the software:

- ["To generate a GNSS signal"](#) on page 28
- ["To use predefined scenarios"](#) on page 29
- ["To generate a multi-constellation GNSS signal"](#) on page 31

To generate a GNSS signal

This step-by-step instruction shows how to generate a GNSS signal with the default configuration of a GPS signal for simple receiver tests.

1. Select "Baseband" > "Satellite Navigation" > "GNSS".
2. Select "General" > "State" > "On".

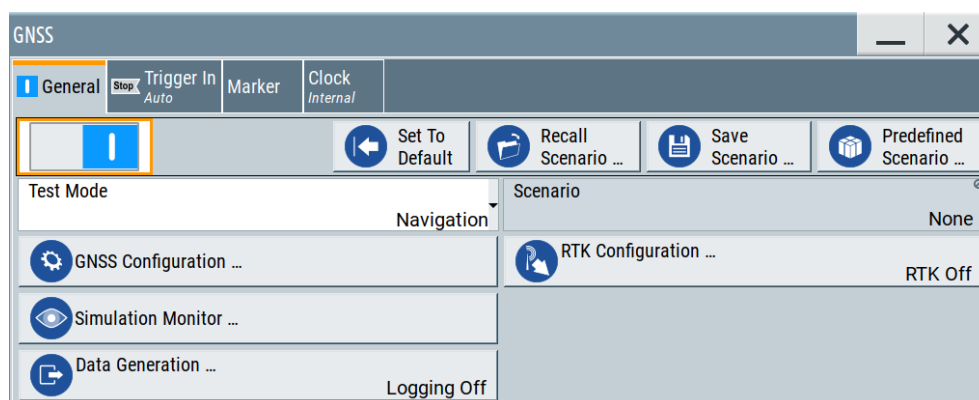

Configured is a GPS signal with C/A signal in the L1 frequency band.

- To observe current satellite constellation, select "GNSS" > "Simulation Monitor".

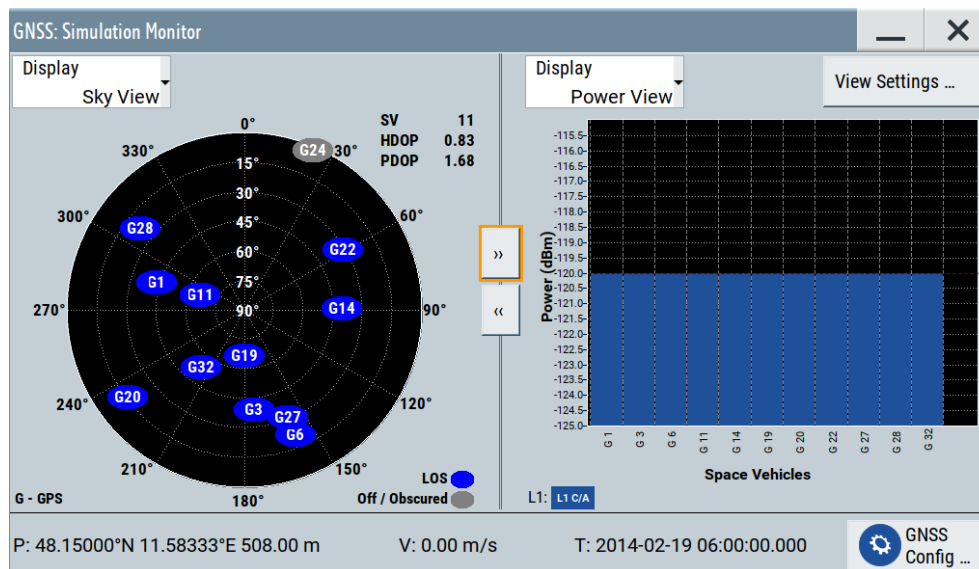

- In the block diagram, select "RF" > "On".

The signal generation starts. The frequency and level of the generated RF signal are configured automatically. Further settings are not required.

For a description of related settings, see:

- [Chapter 3.2, "General settings"](#), on page 32
- [Chapter 3.3, "Simulation monitor"](#), on page 36

To use predefined scenarios

- Select "Baseband" > "Satellite Navigation" > "GNSS".
- Select "General" > "Predefined Scenarios".

The "Predefined Scenario" dialog opens displaying predefined scenarios in a list. See also [Chapter E, "Predefined GNSS scenarios"](#), on page 670.

- Select, for example, "Assisted GNSS" > "3GPP2" > "3GPP2 C.S0036 2.1.2 Moving".
- Select "General" > "State" > "On".

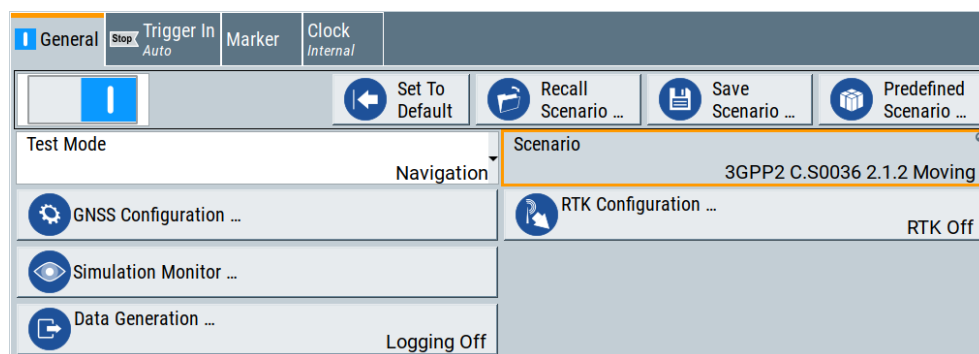

The scenario provides a GPS signal with C/A signal in the L1 frequency band for a moving GNSS receiver.

5. To observe simulation characteristics, open the "Simulation Monitor" dialog:
 - a) For the receiver trajectory, select "Display" > "Map View".
 - b) For the satellite constellation, select "Display" > "Sky View".

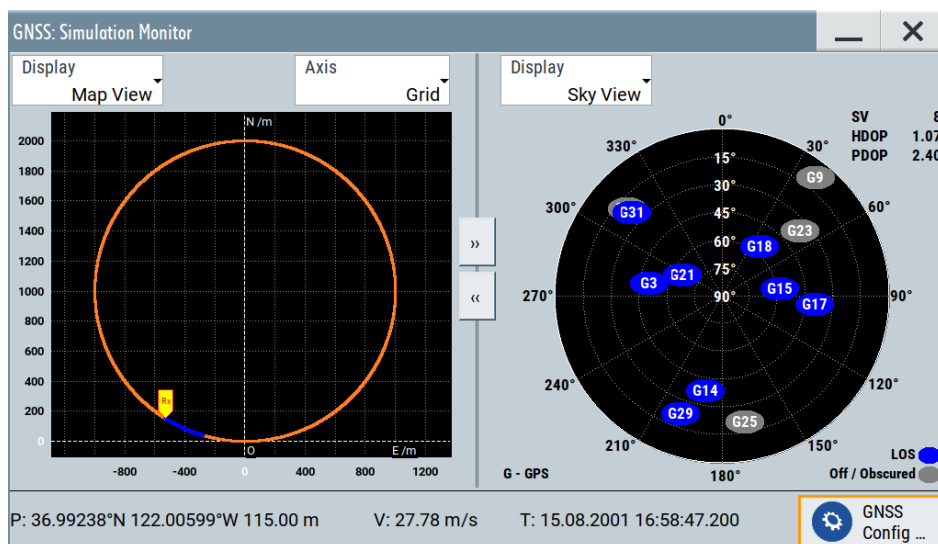

6. To check related settings of the GNSS receiver, select "Simulation Monitor" > "GNSS Config".
 - a) To check general receiver characteristics, select "Receiver".

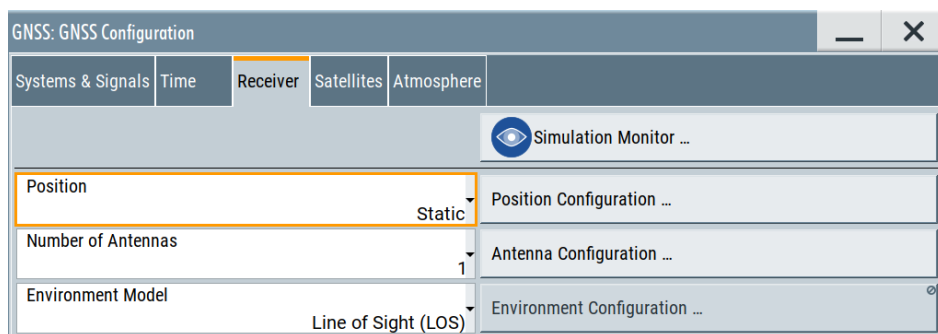

b) To check the receiver position, select "Receiver" > "Position Configuration".

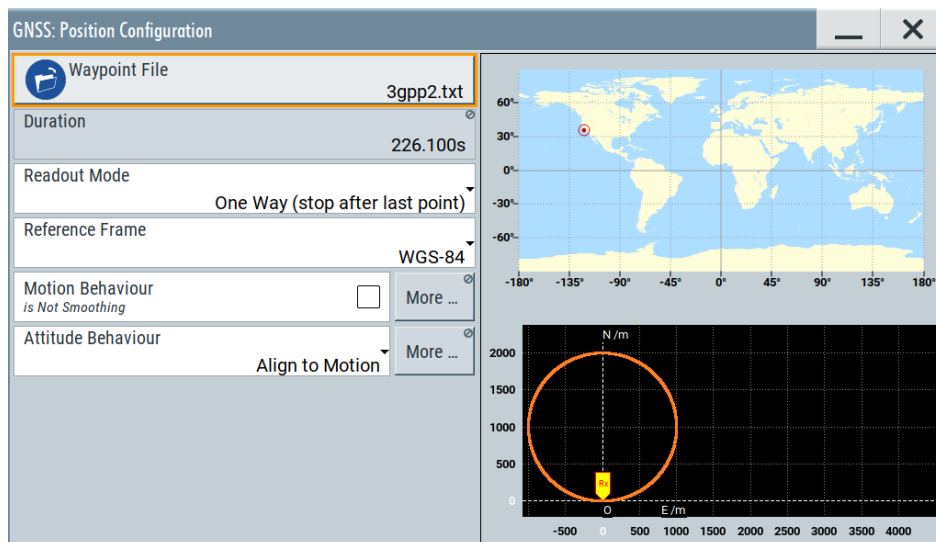

7. In the block diagram, select "RF" > "On".

The signal generation starts. The frequency and level of the generated RF signal are configured automatically. Further settings are not required.

For description of the related settings, see:

- [Chapter 3.2, "General settings"](#), on page 32
- [Chapter 3.3, "Simulation monitor"](#), on page 36
- [Chapter 5, "Receiver type and position"](#), on page 52

To generate a multi-constellation GNSS signal

1. Select "Baseband" > "Satellite Navigation" > "GNSS".
2. Select "GNSS Configuration" > "Systems & Signals".

Systems & Signals		Time	Receiver	Satellites	Atmosphere	Output Streams
	System	L1 Band	L2 Band	L5 Band		
		<input checked="" type="checkbox"/>	<input checked="" type="checkbox"/>	<input checked="" type="checkbox"/>		
GNSS	<input checked="" type="checkbox"/> GPS	C/A,PL1C	C/A,PL2C	L5		
	<input checked="" type="checkbox"/> Galileo	E1 OS	E6	E5a,E5b		
	<input checked="" type="checkbox"/> GLONASS	C/A,CDMA L1	C/A,CDMA L2	CDMA L3		
	<input checked="" type="checkbox"/> BeiDou	B1I,B1C	B3I	B2I,B2a		
RNSS	<input checked="" type="checkbox"/> QZSS	C/A,L1C	L2C	L5		
	<input checked="" type="checkbox"/> NavIC			SPS		
SBAS	<input type="checkbox"/> EGNOS	C/A		Exp L5		
	<input type="checkbox"/> WAAS	C/A		Exp L5		
	<input type="checkbox"/> MSAS	C/A				
	<input type="checkbox"/> GAGAN	C/A				

3. Select the frequency band, for example, set "L1" > "On".
4. Enable the global, regional and augmentation GNSS systems to be simulated, for example, "GPS" > "On", "Galileo" > "On", "GLONASS" > "On".
5. Define the signals per GNSS system, for example, for GPS:
 - a) Enable the C/A signal: Select "GPS" > "C/A" > "On".
 - b) Disable the P signal: Select "GPS" > "P" > "Off".
6. To observe current satellite constellation, select "GNSS" > "Simulation Monitor".
7. To reconfigure constellation settings, select "Simulation Monitor" > "GNSS Config".
8. In the block diagram, select "RF" > "On".

The signal generation starts. The frequency and level of the generated RF signal are configured automatically. Further settings are not required.

For related settings, see:

- [Chapter 3.2, "General settings"](#), on page 32
- [Chapter 3.3, "Simulation monitor"](#), on page 36
- [Chapter 6, "Satellite constellation"](#), on page 68

3.2 General settings

Access:

- ▶ Select "Baseband" > "Satellite Navigation" > "GNSS".

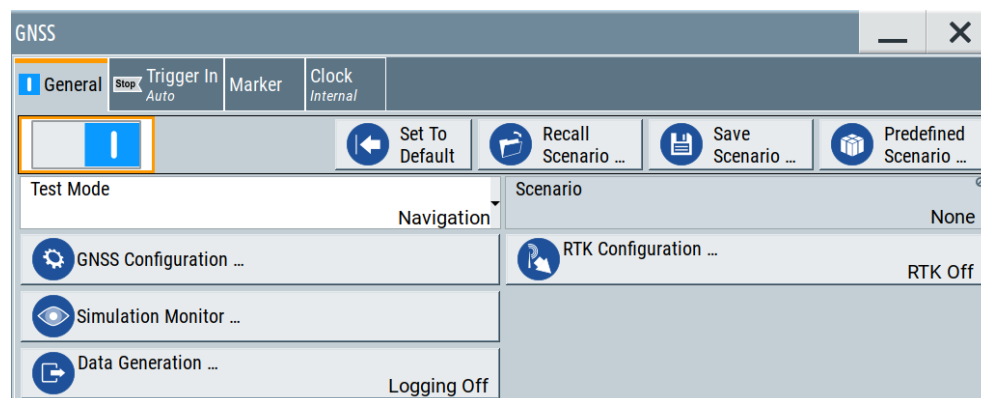

The dialog provides general settings to call the default settings, save and recall settings and access to further settings of the GNSS simulation.

The remote commands required to define these settings are described in [Chapter 22.1, "General commands"](#), on page 356.

Settings:

State.....	33
Set to Default.....	33
Recall Scenario/Save Scenario.....	33
Predefined Scenario.....	34
Scenario.....	34
Test Mode.....	34
GNSS Configuration.....	35
Simulation Monitor.....	35
Data Generation.....	36
RTK Configuration.....	36

State

Activates the standard and deactivates all the other digital standards and digital modulation modes in the same path.

Remote command:

[:SOURce<hw>] :BB:GNSS:STATe on page 357

Set to Default

Calls the default settings. The values of the main parameters are listed in the following table.

Parameter	Value
"State"	Not affected by "Set to default"
"Scenario"	"None"
"Test Mode"	"Navigation"
"Logging"	"Off"
"RTK"	"Off"

Remote command:

[:SOURce<hw>] :BB:GNSS:PRESet on page 357

Recall Scenario/Save Scenario

Accesses the "Save/Recall" dialog, that is the standard instrument function for saving and recalling the complete dialog-related settings in a file. The provided navigation possibilities in the dialog are self-explanatory.

The settings are saved in a file with predefined extension. You can define the filename and the directory, in that you want to save the file.

See also, chapter "File and Data Management" in the R&S SMW200A user manual.

To ensure repeatable test situation, the save file or recall file contains all settings. The scenario includes all files used in the simulation, for example, waypoints files or vehicle description files.

When recalling a scenario, the instrument checks the installed options and the used system configuration. If there is a mismatch, the file is loaded, settings adapted as far as possible and the simulation displays a warning message to indicate this situation.

Remote command:

`[:SOURce<hw>] :BB:GNSS:SETTing:CATalog?` on page 359

`[:SOURce<hw>] :BB:GNSS:SETTing:STORe` on page 359

`[:SOURce<hw>] :BB:GNSS:SETTing:LOAD` on page 360

`[:SOURce<hw>] :BB:GNSS:SETTing:DELeTe` on page 360

Predefined Scenario

Opens the standard "File Select" dialog and allows you to select a predefined scenario.

The available test scenarios depend on the installed software options. For an overview, see [Chapter E, "Predefined GNSS scenarios"](#), on page 670.

Once a scenario is selected, all parameters (simulated position, satellite configuration, navigation data, etc.) are configured automatically. The scenario name is indicated, see ["Scenario"](#) on page 34.

Remote command:

`[:SOURce<hw>] :BB:GNSS:SETTing:CATalog:PREDeFined?` on page 360

`[:SOURce<hw>] :BB:GNSS:SETTing:LOAD:PREDeFined` on page 360

Scenario

Displays a loaded scenario.

"None" No scenario selected (default setting), see ["Set to Default"](#) on page 33.

Predefined scenario

Name of the predefined scenario as selected via ["Predefined Scenario"](#) on page 34.

Predefined scenario *

Name of the predefined scenario with changed settings.

Directory and filename

Directory and filename, when you load a scenario, see ["Recall Scenario/Save Scenario"](#) on page 33.

Remote command:

`[:SOURce<hw>] :BB:GNSS:SCENario?` on page 357

Test Mode

Set the test mode to match the operation mode in that the DUT works.

Irrespectively of the selected mode, initial satellite constellations are defined by the predefined or imported constellation data. Also, the number of active satellites with their initial position and messages are retrieved from constellation data. You can edit the satellite constellation and signals in both modes.

Switching from one test mode to the other presets all satellites parameters to their default values. The modes differ in terms of signal content and scenario complexity:

- "Navigation" The generated signal contains satellite signals to simulate a particular location of a GNSS receiver.
This signal implies a realistic navigation scenario. The DUT can achieve position fix, since the satellite constellation comprises of at least three satellites. The signal is suitable for signal acquisition and TTFF tests.
For more information, see [Chapter 5, "Receiver type and position"](#), on page 52.
- "Tracking" The generated signal contains no positioning data. You do not need to configure the GNSS receiver.
Navigation and acquiring of position fix is not possible. The signal is sufficient to test the ability of the DUT to find the channel and to decode the signal. It is also sufficient for receiver sensitivity testing. Use this mode to simulate high signal dynamics. For example, simulate spinning vehicles and precision code (P code) signals.
For more information, see [Chapter 11, "Tracking mode"](#), on page 181.
- "Matched-Spectrum Interferer"
Requires option R&S SMW-K129.
The generated signal is a tracking mode signal that contains continuous wave (CW) interference signals for all space vehicles of a given satellite constellation. These signals have no navigation message data.
For more information, see ["About the matched-spectrum GNSS interferer"](#) on page 187.
- "Advanced Matched-Spectrum Interferer"
Requires option R&S SMW-K129.
The generated signal is a navigation mode signal that contains continuous wave (CW) interference signals for all space vehicles of a given satellite constellation. These signals have no navigation message data.
For more information, see ["About the matched-spectrum GNSS interferer"](#) on page 187.

Remote command:

[:SOURce<hw>] :BB:GNSS:TMODE on page 358

GNSS Configuration

Opens the "GNSS Configuration" dialog to configure enabled navigation system, RF bands and signals. Also, the dialog provides further settings to configure satellites.

See:

- [Chapter 6.1, "Systems and signals settings"](#), on page 69
- [Chapter 4.1, "Time settings"](#), on page 46
- [Chapter 5.1, "General receiver settings"](#), on page 52
- [Chapter 6.2, "Satellites settings"](#), on page 73
- [Chapter 13.4, "Atmospheric effects and ionospheric errors settings"](#), on page 202

Simulation Monitor

Accesses the "Simulation Monitor" dialog for real-time display of the most important parameters.

These parameters are, for example, the current satellite constellation with SV states and position, receiver position or movement trajectory and received satellite power.

See [Chapter 3.3, "Simulation monitor"](#), on page 36.

Data Generation

Opens the "Data Generation" dialog for enabling and configuring data logging, assistance data generation and generating files by converting. Also, the button displays the logging state ("Logging On"/"Logging Off").

See:

- [Chapter 16, "Data logging"](#), on page 289
- [Chapter 17, "Assistance data generation"](#), on page 299

RTK Configuration

Requires R&S SMW-K122.

Accesses the "RTK Configuration" dialog for enabling and configuring real-time kinematics (RTK) simulation. Also, the button displays the RTK state ("RTK On"/"RTK Off").

See [Chapter 9, "Real-time kinematics"](#), on page 152.

3.3 Simulation monitor

About the simulation monitor

The simulation monitor visualizes the real-world situation of disappearance and reappearance of satellites in real time. It is a dynamic display that provides real-time information on the following:

- Satellite location, satellite states and satellite tracks
- Receiver position and receiver velocity including the current simulation time
- Trajectory of a moving receiver
- Signal power levels of the active satellites and echo signals
- Horizontal dilution of precision (HDOP) and position dilution of precision (PDOP)

To access the functionality

1. Select "GNSS" > "General" > "Simulation Monitor".

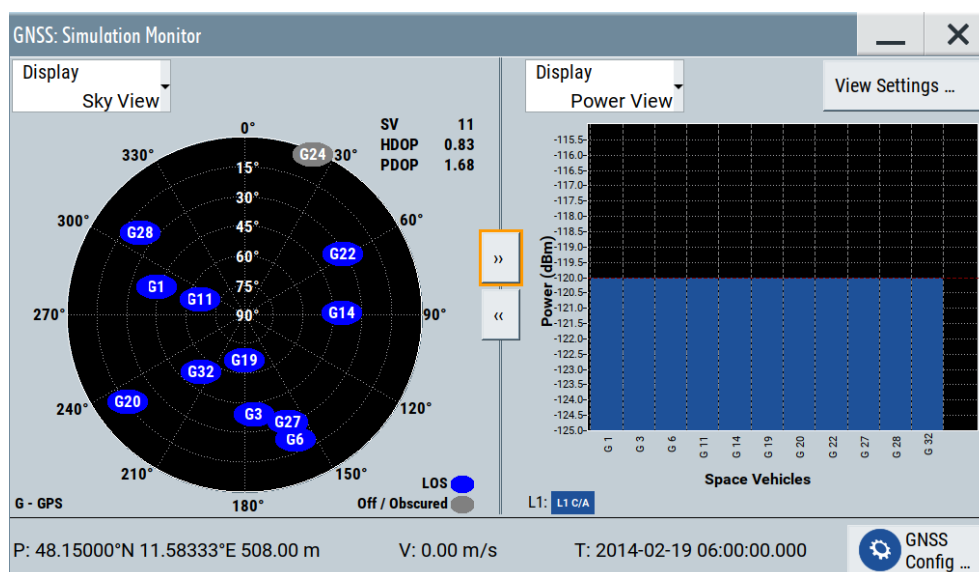

The dialog displays the view that fits best to the settings in the origin dialog.

- To access related settings, select "GNSS Configuration".

The simulation monitor offers different views to monitor characteristics of the GNSS signal. The views cover the following topics.

Settings:

Display.....	37
P/V/T.....	42
GNSS Configuration.....	42
Expand left/right.....	42
SV/HDOP/PDOP.....	42
View Settings.....	43
Show Echoes.....	43
Show Tracks.....	43
Axis.....	44
Yaw / Heading/Pitch / Elev./Roll / Bank.....	44
System.....	44
SV-ID.....	44
Channels.....	44
HW Channels table.....	45

Display

Switches between the available views.

"Sky View" Displays the current position and state (active or inactive) of the satellites in the current satellites constellation. In this display, you can, for example, observe the situation of disappearance and reappearance of satellites.

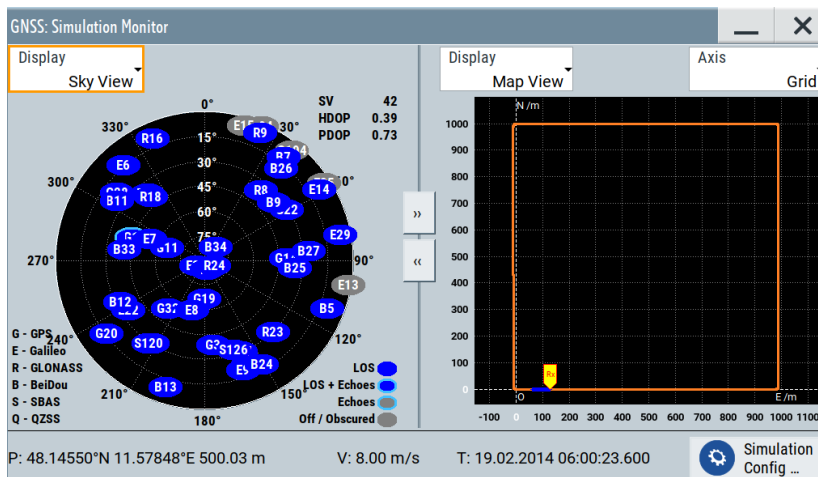

Figure 3-1: Hybrid satellite constellation with obscured satellites in a moving scenario

For instruments equipped with option R&S SMW200A-K108, the "Sky View" indicates also the obscured satellites, the satellites with echoes, etc. For example, the satellites which signal is not visible from the current receivers position because there is an obstacle between the receiver and the satellite, are displayed in gray color.

"Power View" Displays the current power levels of the signals of the active satellites and their echoes.

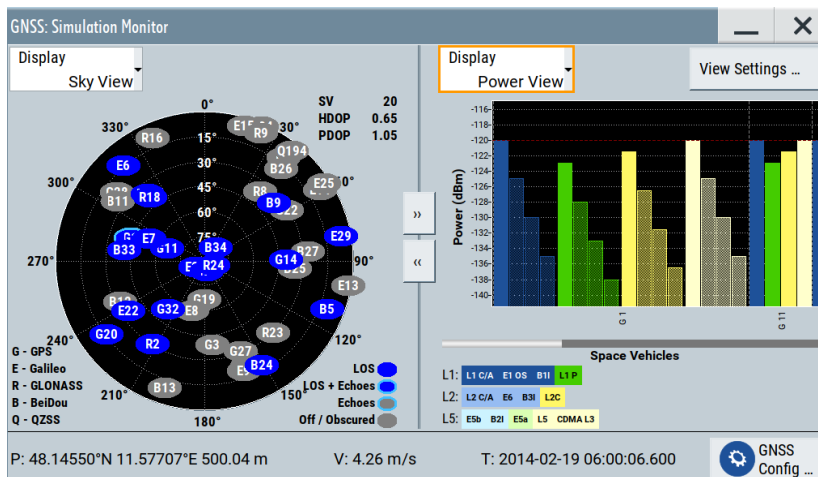

Figure 3-2: Hybrid satellite constellation with obscured satellites and echoes with power signal levels per satellite

"Ground Track"

Displays an aggregated plot of the trajectories of all satellites projected on the world map.

To observe satellite ground tracks, you can show tracks for all and for single satellites:

- For all satellite ground tracks, select "Show Tracks". See "Show Tracks" on page 43.
- For a single satellite ground track, access the "Simulated Orbit" settings of this satellite. See "Ground Track" on page 94.

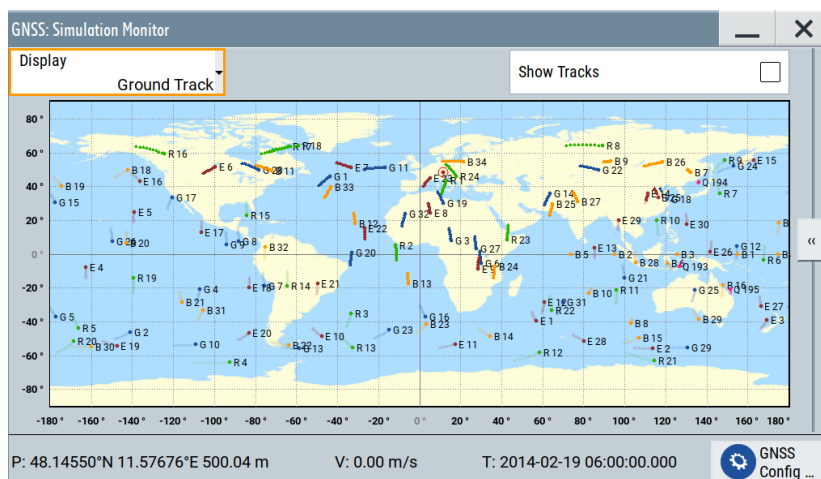

"Map View" Displays the trajectory of a moving receiver or the position of a static one. The blue trajectory displays the last 50 receiver positions, the orange trajectory displays the receiver positions from the last three hours or the expected movement from a waypoint file. If the receiver position reaches the limits of the axes, the scaling is adapted automatically.

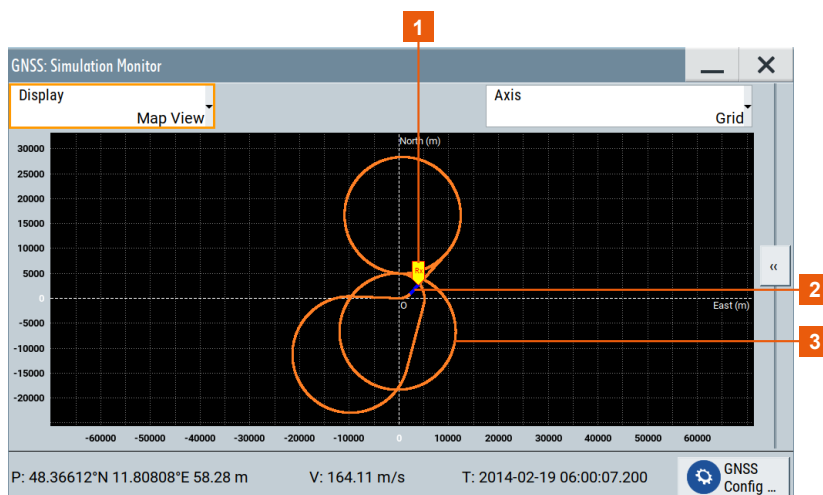

- 1 = Receiver position
- 2 = Blue trajectory: 50 last receiver positions
- 3 = Orange trajectory: receiver positions of the last three hours or the expected movement from a waypoint file

If you analyze the generated GNSS signal with a GNSS receiver software, you can notice a slight difference in the receiver position. The receiver position displayed on the "Map View" and the position displayed on the receiver software can deviate at the beginning of a simulation. The accuracy of the "Map View" display is progressively increasing with the time elapsed and after the first satellite handover the deviation completely disappears.

"Attitude View" Displays a compass showing the geographic direction of a moving receiver, typically an airplane. It also displays an attitude indicator showing the orientation of this airplane relative to earth's horizon.

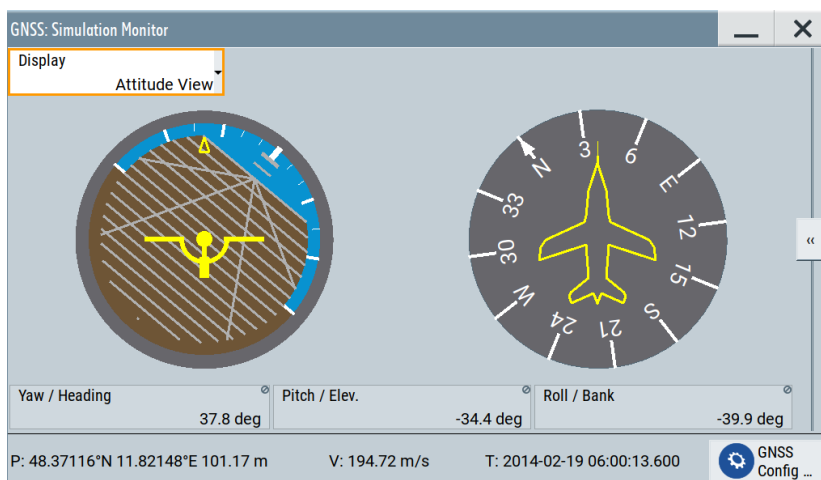

The displayed attitude indicator is known from the flight simulators. The yellow sign in the middle represents the airplane with its nose and wings. The brown part of the display is the earth, whereas the sky is displayed in blue; the line between the two parts is the horizon.

The "Attitude View" changes in real time:

- If the yellow circle, i.e. the nose of the airplane, is on the blue background, then the airplane is nose up.
- If a spinning and roll is enabled, the attitude indicator also visualizes pitch and roll (i.e. bank or side-to-side tilt).

"Elev./Azimuth"

Displays the time variation of the azimuth and the satellite's elevation over 24 hours UTC time. The start time is hour 00:00:00 of the simulated day. The vertical dotted green line indicates the current simulation time and updates in real time. Crossing midnight ("24") triggers a refresh of the two plots.

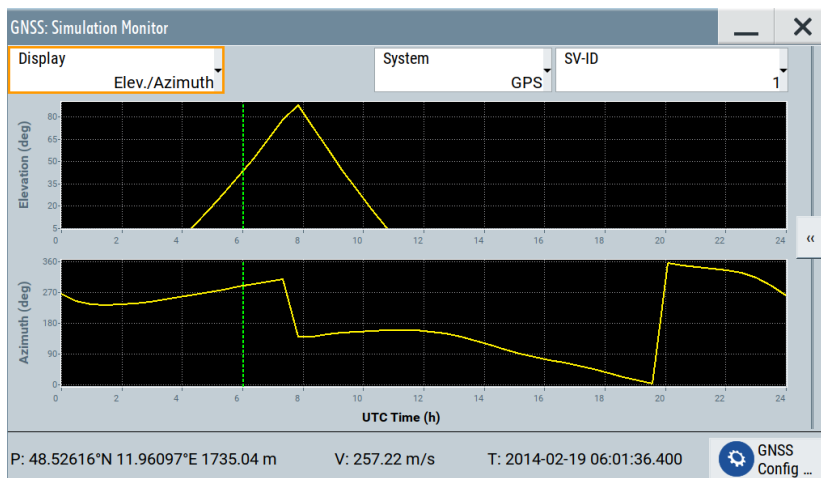

"HW Channels"

Lists the channel information, number of active channels and allocated channels of the composite GNSS signal.



The screenshot shows a window titled "GNSS: Simulation Monitor" with a "Display" dropdown menu set to "HW Channels". The table below shows the channel information:

Chan	Ant	SV	Signal	Path	Power /dBm
1	A1	G1	L1 C/A	LOS	-120.00
2	A1	G1	L1 P	LOS	-123.00
3	A1	G1	L1 C/A	Echo1	-125.00
4	A1	G1	L1 P	Echo1	-128.00

See also:

- ["Channels"](#) on page 44
- ["HW Channels table"](#) on page 45

In GNSS Advanced baseband mode, the channel information is displayed for each GNSS stream, see ["Stream"](#) on page 284.

Remote command:

`[:SOURce<hw>] :BB:GNSS:MONitor<ch> :DISPlay` on page 607

P/V/T

Real-time information for receiver position, receiver velocity and simulation time.

- "P" Receiver position with latitude and longitude in degrees and altitude in meters. See also ["Location Coordinates, Position Format"](#) on page 56.
- "V" Receiver velocity in meter per second
- "T" Date and time in UTC format: YYYY-MM-DD HH:MM:SS. See also ["Simulation Start"](#) on page 48.

GNSS Configuration

Accesses the "GNSS Configuration" dialog to configure the following GNSS settings:

- [Chapter 6.1, "Systems and signals settings"](#), on page 69
- [Chapter 4.1, "Time settings"](#), on page 46
- [Chapter 5, "Receiver type and position"](#), on page 52
- [Chapter 6.2, "Satellites settings"](#), on page 73
- [Chapter 13.4, "Atmospheric effects and ionospheric errors settings"](#), on page 202
- [Chapter 13.2, "Noise and CW interferer settings"](#), on page 192

Expand left/right

Expands the view to the full width of the dialog.

- ">>" Expands the left view to the right.
- "<<" Expands the right view to the left.

SV/HDOP/PDOP

Displays the current HDOP and PDOP value of the selected satellite constellation and the number satellites that these values apply to.

The HDOP and PDOP can be used as an indication of 2D and 3D positioning quality. The general rule here is that the smaller the HDOP and PDOP are, the better the precision of the position fix.

View Settings

Requires "Display" > "Power View".

Accesses a dialog to define visible signals in the graph that displays the signal power levels per satellite. Disable or enable visible signals, for example, in hybrid satellite constellations to highlight visible signals for a specific GNSS.

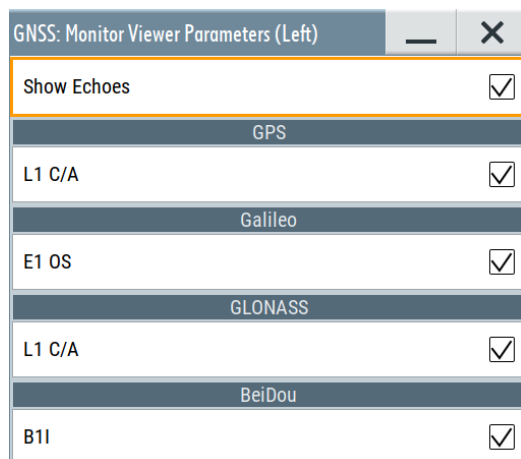

Remote command:

```
[ :SOURCE<hw> ] :BB:GNSS:MONitor<ch>:DISPlay:POWer:SYSTem:GPS:
SIGNal:L1Band:CA on page 611
(etc. for the other GNSS systems)
```

Show Echoes

Requires "Display" > "Power View".

If enabled, the "Power View" graph indicates also the echoes per satellite. Echo signals are present, if you configure a static multipath environment for a receiver with at least one configured echo.

See also:

- [Chapter 8.7.6, "Static multipath"](#), on page 148
- [Figure 7-3](#)

Remote command:

```
[ :SOURCE<hw> ] :BB:GNSS:MONitor<ch>:DISPlay:POWer:ECHOes on page 609
```

Show Tracks

Requires "Display" > "Ground Track".

If enabled, the "Ground Track" view indicates both, the current satellite positions and their orbits.

Remote command:

```
[ :SOURCE<hw> ] :BB:GNSS:MONitor<ch>:DISPlay:TRACks:SHOW on page 608
```

Axis

Requires "Display" > "Map View".

Changes the axis representation of the map. The origin and the distance of the receiver trajectory to the origin stays the same for each representation.

"Grid" Two-dimensional cartesian coordinates in grid-like representation.
 "Circles" Two-dimensional coordinates in circular representation of an eye chart.

Remote command:

`[:SOURCE<hw>] :BB:GNSS:MONitor<ch>:DISPlay:MAP:AXIS` on page 608

Yaw / Heading/Pitch / Elev./Roll / Bank

Requires "Display" > "Attitude".

Displays the receiver attitude parameters yaw/heading (Y), pitch/elevation (P), roll/bank (R) in degrees. The simulation reads out these parameters from the receiver movement file.

For constant attitude behavior, you can configure initial receiver attitude parameters, see "[Attitude Behaviour](#)" on page 57.

System

Requires "Display" > "Elev./Azimuth".

Selects the GNSS for that the simulation varies the satellite elevation and azimuth values.

Remote command:

`[:SOURCE<hw>] :BB:GNSS:MONitor<ch>:DISPlay:TRAJectory:SYSTem` on page 609

SV-ID

Requires "Display" > "Elev./Azimuth".

Selects the space vehicle for that the simulation varies the satellite elevation and azimuth values.

Remote command:

`[:SOURCE<hw>] :BB:GNSS:MONitor<ch>:DISPlay:TRAJectory:SVID` on page 608

Channels

Requires "Display" > "HW Channels".

Displays the number of active GNSS channels ("x") and allocated GNSS channels ("y"). The number of active channels is automatically configured depending on the number of active GNSS systems, signals, satellites, vehicles and antennas. The number of allocated channels is also the maximum number of channels.

A GNSS channel refers to a hardware unit that is required to process and generate a GNSS signal. GNSS channels are uniquely composed of the following configuration elements: One vehicle/receiver, one antenna, one RF band and one signal of a single satellite.

R&S SMW-B9: In GNSS Advanced baseband mode "Channels x/y" are indicated for the selected GNSS stream, see "[Stream](#)" on page 284.

The maximum number of channels depends on the installed options. See [Chapter G, "Channel budget"](#), on page 682.

Remote command:

```
[ :SOURCE<hw> ] :BB:GNSS:MONitor<ch>:DISPlay:CHANnels:USED?
```

on page 612

```
[ :SOURCE<hw> ] :BB:GNSS:MONitor<ch>:DISPlay:CHANnels:ALlocated?
```

on page 611

To set the maximum number of channels of a GNSS stream requires R&S SMW-B9.

```
[ :SOURCE<hw> ] :BB:GNSS:STReam<st>:CHANnels:MAX on page 637
```

HW Channels table

Requires "Display" > "HW Channels".

Lists GNSS channel information in a table.

Table 3-1: HW channels: Understanding the displayed information

Parameter	Description
"BB"	Baseband resource requires R&S SMW-B9
"Veh"	Vehicle number requires R&S SMW-B9
"Ant"	Antenna number
"SV"	Space vehicle with GNSS system and number
"Signal"	Frequency band and signal
"Path"	Type of signal: Line-of-sight (LOS) and echoes
"Power(dBm)"	Channel power

See also:

- [Chapter 15, "Advanced GNSS scenarios"](#), on page 267
- [Chapter G, "Channel budget"](#), on page 682

4 Simulation time

The default system time in this simulation is given in the UTC (Universal Time Coordinates) time base. The simulation start time is thus defined as date and time and is set to 2014-02-19 at 06:00:00 am.

Simulation start time

You can change the simulation start time as you can change the time basis at any time. The time is then automatically recalculated and displayed in the selected time format.

The satellite constellation can comprise SVs from different navigation systems. You can observe the current simulation time converted into the time basis of each of the enabled GNSS systems at a glance.

If the satellite constellation comprises SVs from different navigation standards, the time conversion between the time bases in these navigation standards has to be defined. With other words, the time conversion settings are necessary for switching from one timebase to another.

Time conversion parameters and leap second

Time conversion parameters are zero and first order system clock drift parameters and the current leap second.

The leap second describes the difference between the GPS, Galileo, GLONASS, Bei-Dou or NavIC system time and UTC system time. Correct the time difference by specifying the leap second transition date, the leap second before transition and the leap second after transition.

How to: [Example "Configuring leap second transition"](#) on page 49

Simulating time conversion errors

Per default, the time conversion between the time basis excludes conversion errors and drifts between the time basis of the GNSS systems. We recommend that you use the default configuration, without system time offset or time drift.

If you aim to simulate deliberate errors and change the time conversion settings, see:

- ["Additional UTC Parameters"](#) on page 50
- [Chapter 13.8, "Time conversion errors settings"](#), on page 227

4.1 Time settings

Access:

1. Select "GNSS" > "GNSS Configuration" > "Time".

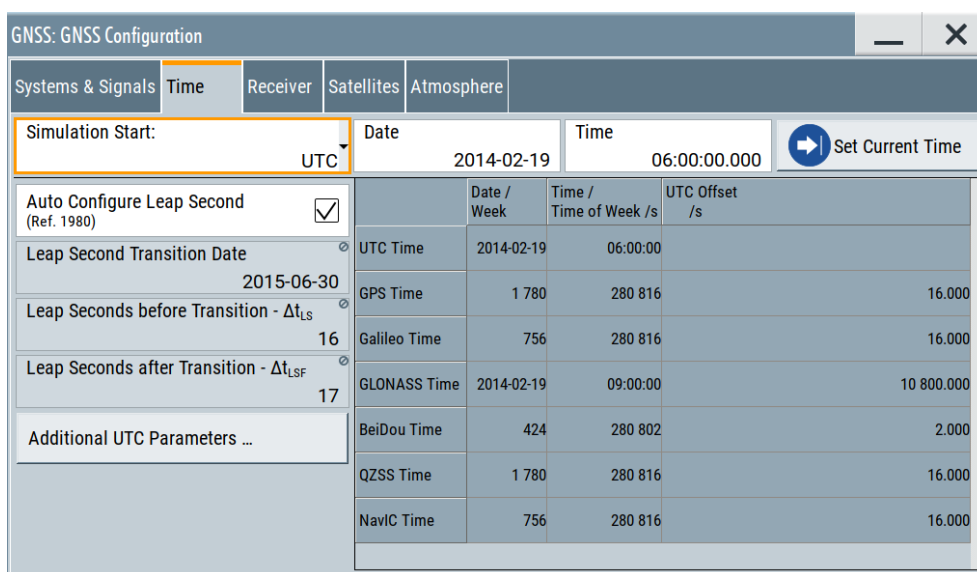

2. Select "Additional UTC Parameters".

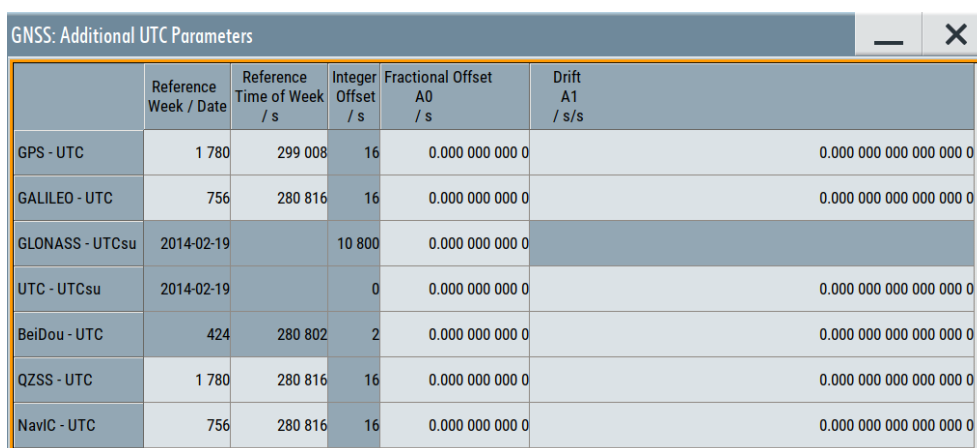

These dialogs contain the settings required to configure the time conversion from a navigation standard, for example GPS to UTC. The conversion settings are necessary for switching from one timebase to another.

Settings

Simulation Start.....48

Set Current Time.....48

Leap Second Configuration.....49

 L Auto Configure Leap Second (Ref. 1980).....49

 L Leap Second Transition Date.....49

 L Leap Second before Transition - Δt_{LS}49

 L Leap Second after Transition - Δt_{LSF}49

Date / Week, Time / Time of Week / s, UTC Offset / s.....50

Additional UTC Parameters.....50

 L Reference Week/Date, Reference Time of Week.....50

↳ UTC-UTC(SU).....	50
↳ Integer Offset.....	50
↳ Fractional Offset A0, Drift A1.....	51

Simulation Start

Sets the simulation start date and time in the selected format.

"Format" Per default, the UTC format used. If different format is selected, the time is automatically recalculated.

Note: Use the [Additional UTC Parameters](#) dialog to configure the parameters, necessary for time conversion between the proprietary time of the navigation standard and the UTC.

Remote command:

`[:SOURCE<hw>] :BB:GNSS:TIME:START:TBASIS` on page 371

"Date [yyyy-mm-dd], Time [hh:mm:ss.xxx]"

Enters the date for the simulation in format YYYY-MM-DD (ISO 8601). The date corresponds to the Gregorian calendar and the exact simulation start time in UTC time format.

Remote command:

`[:SOURCE<hw>] :BB:GNSS:TIME:START:DATE` on page 370

`[:SOURCE<hw>] :BB:GNSS:TIME:START:TIME` on page 371

"Week Number, Time of Week (TOW)"

The satellite clocks in the GPS and Galileo navigation systems are not synchronized to the UTC. They use a proprietary time, the GPS and the Galileo system time. The format used for these systems is week number (WN) and time of week (TOW), that is the simulation start time within this week.

TOW is expressed in number of seconds and covers an entire week. The value is reset to zero at the end of each week.

The weeks are numbered starting from a reference time point (WN_REF=0), that depends on the navigation standard:

- GPS reference point: January 6, 1980 (1980-01-06, 00:00:00 UTC)
- GALILEO reference point: August 22, 1999 (1999-08-22)
- BeiDou reference point: January 01, 2006 (2006-01-01)
- NavIC reference point: August 22, 1999 (1999-08-22)

Remote command:

`[:SOURCE<hw>] :BB:GNSS:TIME:START:WNUMBER` on page 372

`[:SOURCE<hw>] :BB:GNSS:TIME:START:TOWEEK` on page 372

Set Current Time

Applies date and time settings of the operating system to the simulation start time.

To access the operating system time settings, select "System Config" > "Setup" > "Maintenance" > "Date / Time".

Remote command:

`[:SOURCE<hw>] :BB:GNSS:TIME:START:SCTIME` on page 371

Leap Second Configuration

Configure leap second transitions for time corrections between UTC system time and the individual GNSS time.

Example: Configuring leap second transition

The examples below comprise leap second transitions before/after the set transition date. Also, the functionality allows you to configure no leap second transition at an arbitrary transition date.

- Leap second transition in the future:
Set simulation start "Date" > "2014-02-19", "Leap Second Transition Date" > "2015-06-30", "Leap Second before Transition - Δt_{LS} " > "16", "Leap Second after Transition - Δt_{LSF} " > "17".
- Leap second transition in the past, no other transition event announced:
Set simulation start "Date" > "2019-12-10", "Leap Second Transition Date" > "2016-12-31", "Leap Second before Transition - Δt_{LS} " > "17", "Leap Second after Transition - Δt_{LSF} " > "18".
- No leap second transition at an arbitrary transition date:
Set simulation start "Date" > "2019-12-10", "Leap Second Transition Date" > "yyyy-mm-dd", "Leap Second before Transition - Δt_{LS} " > "17", "Leap Second after Transition - Δt_{LSF} " > "17".

Auto Configure Leap Second (Ref. 1980) ← Leap Second Configuration

Sets the leap second value according to the simulation time.

Remote command:

[\[:SOURCE<hw>\]:BB:GNSS:TIME:CONVersion:LEAP:AUTO](#) on page 372

Leap Second Transition Date ← Leap Second Configuration

Editing the parameter requires "Auto Configure Leap Second (Ref. 1980)" > "Off".

Defines the date of the next UTC time correction in format YYYY-MM-DD (ISO 8601). You can transit leap seconds by adding or subtracting one second to the leap second value before transition.

Remote command:

[\[:SOURCE<hw>\]:BB:GNSS:TIME:CONVersion:LEAP:DATE](#) on page 373

Leap Second before Transition - Δt_{LS} ← Leap Second Configuration

Editing the parameter requires "Auto Configure Leap Second (Ref. 1980)" > "Off".

Specifies the leap second value Δt_{LS} before the leap second transition.

Remote command:

[\[:SOURCE<hw>\]:BB:GNSS:TIME:CONVersion:LEAP:SEConds:BEFore](#) on page 373

Leap Second after Transition - Δt_{LSF} ← Leap Second Configuration

Editing the parameter requires "Auto Configure Leap Second (Ref. 1980)" > "Off".

Specifies the leap second value Δt_{LSF} after the leap second transition.

Remote command:

[:SOURCE<hw>] :BB:GNSS:TIME:CONVersion:LEAP:SEConds:AFTer
on page 373

Date / Week, Time / Time of Week /s, UTC Offset /s

Displays overview information on the parameters used for the time conversion between the different navigation standards.

The basis for the time conversion is the UTC. The parameters of each of the navigation standards are set as an offset to the UTC.

For in-depth configuration, use the "Additional UTC Parameters" on page 50 dialog.

Remote command:

[:SOURCE<hw>] :BB:GNSS:TIME:START:UTC:DATE? on page 374
[:SOURCE<hw>] :BB:GNSS:TIME:START:UTC:TIME? on page 374
[:SOURCE<hw>] :BB:GNSS:TIME:START:UTC:OFFSet? on page 375
[:SOURCE<hw>] :BB:GNSS:TIME:START:GPS:WNUMber? on page 374
[:SOURCE<hw>] :BB:GNSS:TIME:START:GPS:TOWeek? on page 375
[:SOURCE<hw>] :BB:GNSS:TIME:START:GPS:OFFSet? on page 375
(etc. for the other GNSS systems)

Additional UTC Parameters

Sets the time conversion parameters required for switching from one timebase to another, for example GPS to UTC. The time conversion is performed according to the following equation:

$t_{UTC} = (t_E - \text{delta_}t_{UTC}) \text{ modulo } 86400$, where:

- $\text{delta_}t_{UTC} = \text{delta_}t_{LS} + A_0 + A_1 (t_E - T_{ot} + 604800(WN - WN_{ot}))$
- $t_E = t_{GPS}$ or $t_{Galileo}$

Reference Week/Date, Reference Time of Week ← Additional UTC Parameters

Sets the reference data and time per navigation standard.

Remote command:

[:SOURCE<hw>] :BB:GNSS:TIME:CONVersion:GPS:UTC:WNOT on page 376
[:SOURCE<hw>] :BB:GNSS:TIME:CONVersion:GPS:UTC:TOT on page 377
[:SOURCE<hw>] :BB:GNSS:TIME:CONVersion:GPS:UTC:TOT:UNSCaled
on page 377
(etc. for the other GNSS systems)

UTC-UTC(SU) ← Additional UTC Parameters

For GLONASS satellites, indicates the UTC-UTC (SU) time conversion reference date.

Remote command:

[:SOURCE<hw>] :BB:GNSS:TIME:CONVersion:UTCSu:UTC:DATE? on page 376

Integer Offset ← Additional UTC Parameters

Indicates the integer offset.

Remote command:

[:SOURCE<hw>] :BB:GNSS:TIME:CONVersion:GPS:UTC:IOFFset? on page 378
(etc. for the other GNSS systems)

Fractional Offset A0, Drift A1 ← Additional UTC Parameters

Sets the time parameters constant term of polynomial, A_0 and 1st order term of polynomial, A_1 .

Remote command:

`[:SOURCE<hw>] :BB:GNSS:TIME:CONVersion:GPS:UTC:AZERo` on page 379

`[:SOURCE<hw>] :BB:GNSS:TIME:CONVersion:GPS:UTC:AZERo:UNSCaled`
on page 379

`[:SOURCE<hw>] :BB:GNSS:TIME:CONVersion:GPS:UTC:AONE` on page 380

`[:SOURCE<hw>] :BB:GNSS:TIME:CONVersion:GPS:UTC:AONE:UNSCaled`
on page 380

(etc. for the other GNSS systems)

5 Receiver type and position

Throughout this description, receiver is a term describing a summary of conditions. The conditions comprise receiver coordinates and movement, including the description of the used vehicle, the number and characteristics of used antennas, surrounding environment or environment effects.

This section focuses on the receiver type and position. For a description of the environmental effects and the antenna characteristics, see [Chapter 8, "Real-world environment"](#), on page 106.

The following receiver types can be simulated:

- **Static receiver**
A receiver with fixed coordinates, given as ECEF WGS84 or PZ-90.11 coordinates. You can select from a subset of predefined positions or define a specific one. Regardless of the used coordination system, the latitude, longitude and the altitude can be set in DEG:MIN:SEC format or as decimal degrees.
- **Moving receiver**
A receiver with varying coordinates, defined in movement and motion files. You can select from a subset of predefined files or load custom-specific files. Moreover, waypoint smoothing can be activated if vehicle description files are used.
- **Looped receiver**
A receiver is looped with the R&S SMW200A and a control application. The R&S SMW200A is remotely controlled by the control application, which processes position, motion and attitude data sent by the receiver. The receiver receives a GNSS signal from the R&S SMW200A based on the remote control data of a control application.
You can select from a subset of predefined HIL position files or load custom-specific files. Moreover, waypoint smoothing can be activated based on real-time data received from the control application.

For more information on the supported file formats, see:

- ["Waypoint File"](#) on page 62
- [Chapter A.1, "Movement or motion files"](#), on page 650
- [Chapter A.2, "Vehicle description files"](#), on page 662

5.1 General receiver settings

Access:

1. Select "GNSS" > "GNSS Configuration" > "Receiver".

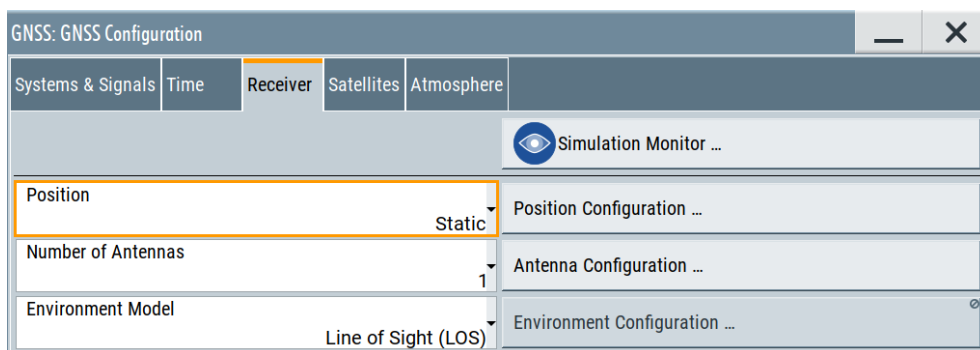

The dialog provides general settings to configure a GNSS receiver.

2. Select "Simulation Monitor" to observe the current receiver configuration.

Settings:

[Position](#)..... 53
[Position Configuration](#)..... 53
[Number of Antennas](#)..... 54
[Antenna Configuration](#)..... 54

Position

Determines what kind of receiver is simulated.

- "Static" Receiver at one of the predefined or at a user-defined position. See [Chapter 5.2, "Static receiver"](#), on page 54.
- "Moving" Receiver that is moving according to a trajectory as described in a file. Use a moving receiver to simulate pedestrians, cars, ships, or airplanes. See [Chapter 5.3, "Moving receiver"](#), on page 59.
- "Remote Control (HiL)" Option: R&S SMW-K109 The receiver is part of a setup for hardware in the loop (HiL) testing. It receives the GNSS signal and transmits position data to a motion simulator. An external simulation software controls the R&S SMW200A and the motion simulator. For details, see [Chapter 19.2, "HiL settings"](#), on page 321.

Remote command:

`[:SOURce<hw>] :BB:GNSS:RECeiver [:V<st>] :POSition` on page 382

Position Configuration

Accesses the position configuration dialog. You can configure the position of a GNSS receiver or of an RTK base station.

The GNSS receiver position depends on the GNSS receiver type:

- [Chapter 5.2, "Static receiver"](#), on page 54
- [Chapter 5.3, "Moving receiver"](#), on page 59
- [Chapter 19.2, "HiL settings"](#), on page 321

To configure the position of the RTK base station, see [Chapter 9.4, "RTK position configuration"](#), on page 157.

Number of Antennas

Defines the number of configurable antennas.

You can create a pool of up to four antenna and body masks and switch between them. To define which antenna is simulated, set "A#" > "Active".

Note: Switching between the active antenna restarts the simulation.

Remote command:

`[:SOURce<hw>] :BB:GNSS:RECEiver [:V<st>] :ANTenna:COUNT` on page 390

Antenna Configuration

Accesses the antenna configuration dialog. You can configure antennas of a GNSS receiver or of an RTK base station.

To configure antennas of a GNSS receiver, see [Chapter 8.6, "Antenna and body mask settings"](#), on page 125.

To configure the antenna of an RTK base station, see [Chapter 9.5, "RTK antenna configuration"](#), on page 160.

5.2 Static receiver

Access:

1. Select "GNSS" > "GNSS Configuration" > "Receiver".
2. Select "Positioning" > "Static".
3. Select "Positioning Configuration".

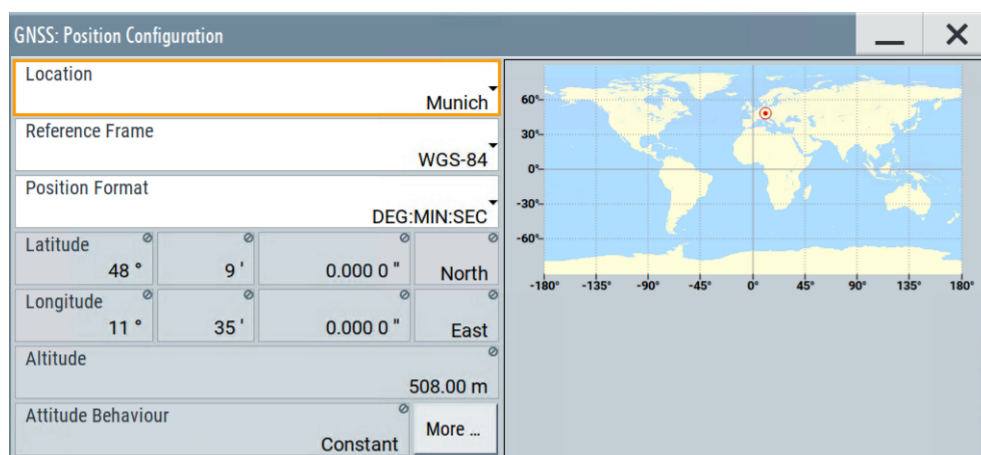

Settings:

Location, Initial Position..... 55
 Reference Frame..... 56
 Location Coordinates, Position Format..... 56
 Attitude Behaviour..... 57
 More..... 58

Location, Initial Position

Selects the location or initial position depending on the simulated object:

- Static GNSS receiver ("Position > Static"): Selects the geographic location of the GNSS receiver.
- R&S SMW-K109: Hardware in the loop (HIL) GNSS receiver ("Position > From Remote"): Selects the initial position of the GNSS receiver.
- R&S SMW-K122: Real-time kinematics (RTK) base station: Selects the geographic location of the RTK base station.

The representation of the coordinates depends on the selected "Reference Frame" and "Position Format".

"User Defined" Sets the receiver position in terms of "Latitude", "Longitude" and "Altitude"

"City" Selects a predefined geographic location, see [Table 5-1](#) for an overview. The parameters "Latitude", "Longitude" and "Altitude" are set automatically.

Table 5-1: Coordinates of the simulated predefined positions

Continent	City	Latitude [deg]	Longitude [deg]	Altitude [m]
Europe	London	51.500625	-0.1246219	22
	Moscow	55.7522222	37.6155556	200
	Munich	48.15	11.5833333	508
	Paris	48.8584	2.2946278	66
America	New York	40.714667	-74.0063889	1
	San Francisco	37.8194389	-122.4784939	35
	Anchorage	61.2166667	-149.8833333	115
	Mexico City	19.4510539	-99.1255189	2310
	Bogota	4.7111111	-74.0722222	2640
	Sao Paulo	-23.5337731	-46.62529	760
	Santiago de Chile	-33.4474869	-70.6736758	522
Asia	Beijing	39.9055556	116.3913889	60
	New Delhi	28.6138889	77.2088889	77
	Seoul	37.5514997	126.9877939	265
	Singapore	1.3113108	103.8268528	110

Continent	City	Latitude [deg]	Longitude [deg]	Altitude [m]
	Taipei	25.0223439	121.5147581	10
	Tokyo	35.6838611	139.7450581	45
Africa	Cairo	30.0444419	31.2357117	23
	Dakar	14.7166769	-17.4676858	22
	Cape Town	-33.9188611	18.4233	6
Australia	Sydney	-33.8833333	151.2166667	3
	Perth	-31.9535119	115.8570481	2

Remote command:

`[:SOURCE<hw>] :BB:GNSS:RECEIVER[:V<st>]:LOCATION:CATALOG`
on page 382

`[:SOURCE<hw>] :BB:GNSS:RECEIVER[:V<st>]:LOCATION[:SELECT]`
on page 383

`[:SOURCE<hw>] :BB:GNSS:RTK:BASE<st>:LOCATION:CATALOG` on page 396

`[:SOURCE<hw>] :BB:GNSS:RTK:BASE<st>:LOCATION[:SELECT]` on page 396

Reference Frame

For GNSS receiver, selects the reference frame used to define the receiver coordinates. The transformation between the reference frames is performed automatically.

R&S SMW-K122: For RTK base station, selects the reference frame used to define the receiver or RTK base station coordinates. The transformation between the reference frames is performed automatically.

The following applies:

- $X_{WGS84} = (1 - 0.008 \cdot 10^{-6}) \cdot X_{PZ90} - 0.2041 \cdot 10^{-7} \cdot Y_{PZ90} + 0.1716 \cdot 10^{-7} \cdot Z_{PZ90} - 0.013$
- $Y_{WGS84} = (1 - 0.008 \cdot 10^{-6}) \cdot Y_{PZ90} - 0.2041 \cdot 10^{-7} \cdot X_{PZ90} + 0.1115 \cdot 10^{-7} \cdot Z_{PZ90} + 0.106$
- $Z_{WGS84} = (1 - 0.008 \cdot 10^{-6}) \cdot Z_{PZ90} - 0.1716 \cdot 10^{-7} \cdot X_{PZ90} - 0.1115 \cdot 10^{-7} \cdot Y_{PZ90} + 0.022$

Both reference frames are ECEF frames with a set of associated parameters.

"WGS-84" The World Geodetic System WGS-84 is the reference frame used by GPS.

"PZ 90.11 (GLONASS)"

Parametry Zemli PZ (Parameters of the Earth) is the reference frame used by GLONASS.

Remote command:

`[:SOURCE<hw>] :BB:GNSS:RECEIVER[:V<st>]:LOCATION:COORDINATES:RFRAME`
on page 383

`[:SOURCE<hw>] :BB:GNSS:RTK:BASE<st>:LOCATION:COORDINATES:RFRAME`
on page 396

Location Coordinates, Position Format

In the ECEF coordinate system, a geographic location is identified by three coordinates, the altitude, latitude and longitude. The last two can be displayed in decimal or DMS format. The display format is determined by the parameter "Position Format".

Parameter	Description
"Position Format"	Sets the format in which the Latitude and Longitude are displayed. <ul style="list-style-type: none"> "DEG:MIN:SEC" The display format is Degree:Minute:Second and Direction, i.e. XX°XX'XX.XX" Direction, where direction can be North/South and East/West. "Decimal Degrees" The display format is decimal degrees, i.e. +/-XX.XXXXXX°, where "+" indicates North and East and "-" indicates South and West.
"Altitude"	Sets the altitude of the reference location. The altitude value is the height above the ellipsoid (HAE), that is the reference ellipsoid (WGS84 or PZ90).
"Latitude"	Sets the latitude of the reference location.
"Longitude"	Sets the longitude of the reference location.

Altitude, latitude and longitude are configurable, if "Location, Initial Position > User Defined".

Remote command:

`[:SOURCE<hw>] :BB:GNSS:RECEIVER[:V<st>]:LOCATION:COORDINATES:FORMAT` on page 383

`[:SOURCE<hw>] :BB:GNSS:RTK:BASE<st>:LOCATION:COORDINATES:FORMAT` on page 397

To enter the coordinates in "Position Format > DEG:MIN:SEC"

`[:SOURCE<hw>] :BB:GNSS:RECEIVER[:V<st>]:LOCATION:COORDINATES:DMS:PZ` on page 384

`[:SOURCE<hw>] :BB:GNSS:RECEIVER[:V<st>]:LOCATION:COORDINATES:DMS[:WGS]` on page 384

`[:SOURCE<hw>] :BB:GNSS:RTK:BASE<st>:LOCATION:COORDINATES:DMS:PZ` on page 398

`[:SOURCE<hw>] :BB:GNSS:RTK:BASE<st>:LOCATION:COORDINATES:DMS[:WGS]` on page 398

To enter the coordinates in "Position Format > Decimal Degrees"

`[:SOURCE<hw>] :BB:GNSS:RECEIVER[:V<st>]:LOCATION:COORDINATES:DECIMAL:PZ` on page 384

`[:SOURCE<hw>] :BB:GNSS:RECEIVER[:V<st>]:LOCATION:COORDINATES:DECIMAL[:WGS]` on page 384

`[:SOURCE<hw>] :BB:GNSS:RTK:BASE<st>:LOCATION:COORDINATES:DECIMAL:PZ` on page 397

`[:SOURCE<hw>] :BB:GNSS:RTK:BASE<st>:LOCATION:COORDINATES:DECIMAL[:WGS]` on page 397

Attitude Behaviour

Sets the attitude characteristics of the receiver.

To define the individual attitude parameters for all attitude behaviors, select "More". This button is available with option R&S SMW-K108.

"Constant" Sets the attitude of the receiver as a combination of the "Yaw / Heading", "Pitch / Elevation", "Roll / Bank" values. The resulting attitude is a constant value.

"Spinning" Enables a constant rate of change of the roll.
See ["Spinning Rate"](#) on page 67.

"From Waypoint File"/"Align to Motion"
Option: R&S SMW-K108
For "Receiver" > "Position" > "Moving", the attitude parameters are extracted from the selected waypoint file. Further settings are not required.
This extraction forces the attitude parameters to motion direction even if the waypoint has attitude information, like, for example, in a *.xtd file with `<property waypointformat="position_attitude">`.
For specific applications like automotive, it is realistic to set the yaw and pitch to the motion direction of the vehicle. The usual body axes angles of a vehicle point to the direction of the velocity vector.
For other applications, however, like aeronautics with a landing plane, this parameter is not useful. AS an example, the nose of the plane is in an upward direction at the time when the plane is moving downwards.
To visualize the effect, select "Receiver" > "Monitor" > "Attitude View", see ["Display"](#) on page 37.

"From Remote"
Option: R&S SMW-K109
For "Receiver" > "Position" > "Remote Control (HIL)", the attitude parameters are set by the received HIL commands. The selection is suspended.

Remote command:
`[:SOURCE<hw>] :BB:GNSS:RECEIVER [:V<st>] :ATTITUDE [:BEHAVIOUR]`
on page 386

More

Opens a dialog to configure more receiver motion settings or more receiver attitude settings.

More receiver motion settings require the following:

- Receiver "Position" > "Moving"
- Receiver position configuration "Motion Behaviour" > "is Smoothing".

For related settings, see ["Vehicle Description File"](#) on page 66.

More receiver attitude settings require the following:

- Option R&S SMW-K108
- Receiver "Position" > "Static" or "Moving"
- Receiver position configuration "Attitude Behaviour" > "Spinning" or "Constant".

For related settings, see ["Yaw / Heading, Pitch / Elevation, \(Start\) Roll / Bank"](#) on page 67.

Remote command:
n.a.

5.3 Moving receiver

5.3.1 Configuring a moving receiver

This section provides step-by-step procedures to define a moving receiver. It covers the following topics:

- "To open moving receiver settings" on page 59
- "To load and play a waypoint file" on page 59
- "To monitor receiver movement characteristics" on page 60
- "To export a predefined waypoint file" on page 60

To open moving receiver settings

- See [Chapter 5.3.2, "Receiver position settings"](#), on page 61.

To load and play a waypoint file

1. In the "Position Configuration" dialog, click "Waypoint File".

A standard file-select dialog opens, where you can select predefined waypoint files or user-defined waypoint files.

2. Select, for example, the predefined waypoint file `Munich_Car_Motion.xtd`.

The file is loaded to the "Waypoint File" selection. The trajectory duration is read-out from the file automatically. The parameters "Latitude", "Longitude" and "Altitude" are set according to the first simulated position.

A world map indicates the initial position of the receiver. Also, the trajectory of the receiver movement is displayed in a graph with east coordinates (x-axis) and north coordinates (y-axis).

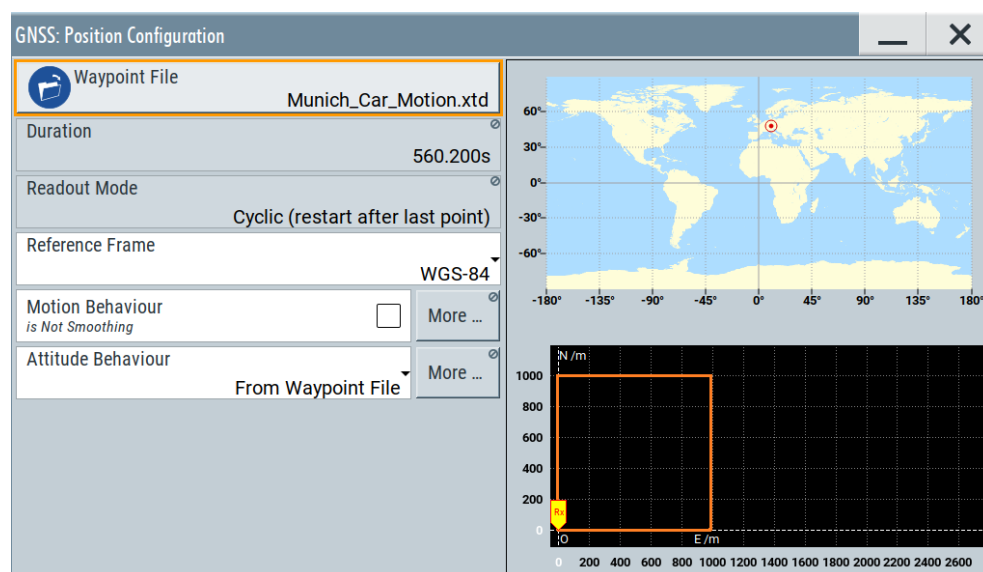

To monitor receiver movement characteristics

After [loading and playing](#) a waypoint file, for example, the file `Munich_Car_Motion.xtd`, you can monitor movement characteristics in real time and more detailed.

1. Select "Receiver" > "Simulation Monitor".

The "Simulation Monitor" dialog opens. Per default, it displays the "Ground Track" view including the receiver position and the "Map View" displaying the current receiver movement along a defined trajectory.

The blue trajectory displays the last 50 receiver positions, the orange trajectory displays the expected movement from a waypoint file.

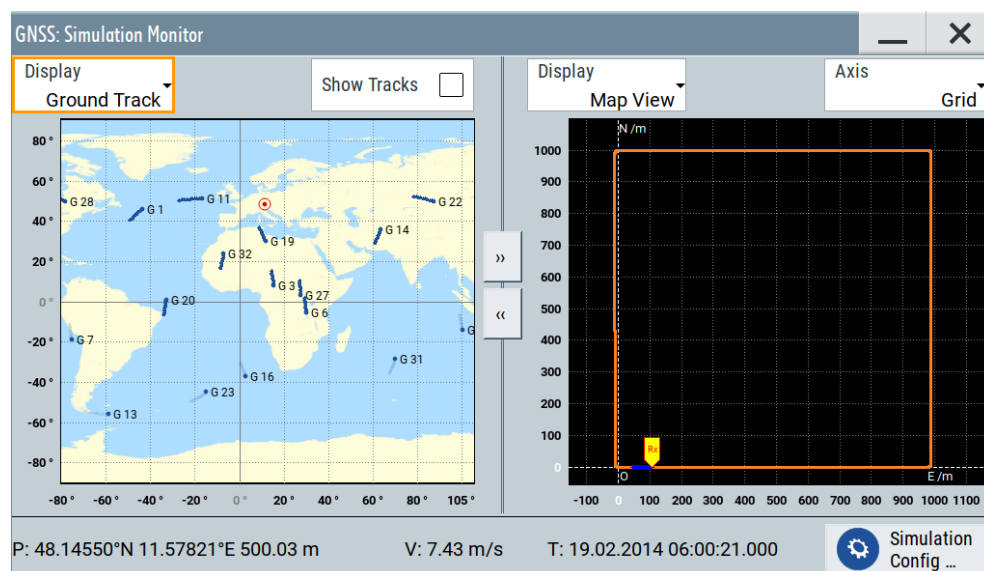

2. To monitor further characteristics due to receiver movement, try out the following:
 - Select "Display" > "Sky View" to monitor changes in the satellite constellation.
 - Select "Display" > "Attitude View" to monitor the geographic direction of the receiver. Also monitor the attitude indicator showing the orientation of the receiver relative to earth's horizon.
 - Select "Display" > "Elevation/Azimuth", to monitor the time variation of the azimuth and the satellite's elevation over 24 hours.

See also ["Display"](#) on page 37.

To export a predefined waypoint file

Export a predefined waypoint file to modify it, for example, the waypoints defining the trajectory.

1. Open the "Waypoint File" > "Predefined Files" dialog as in step 1 of ["To load and play a waypoint file"](#) on page 59.
2. Select a file, for example `Munich_Car_Motion.xtd`.
3. Click "Export".

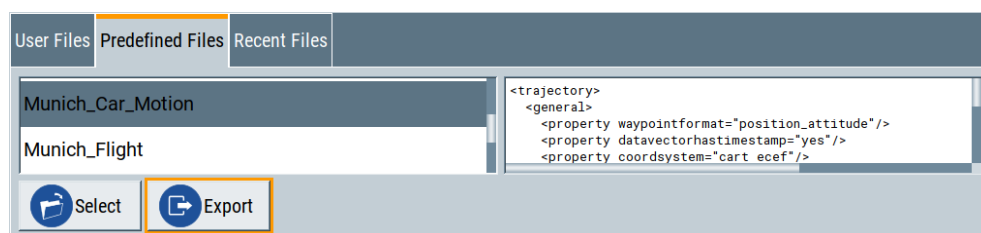

The "User Files" tab opens displaying the exported file in the directory `/var/user`. The filename is modified by adding `_exported` to the original filename. For example, the file `Munich_Car_Motion_exported.xtd` is the exported file from the predefined file `Munich_Car_Motion.xtd`.

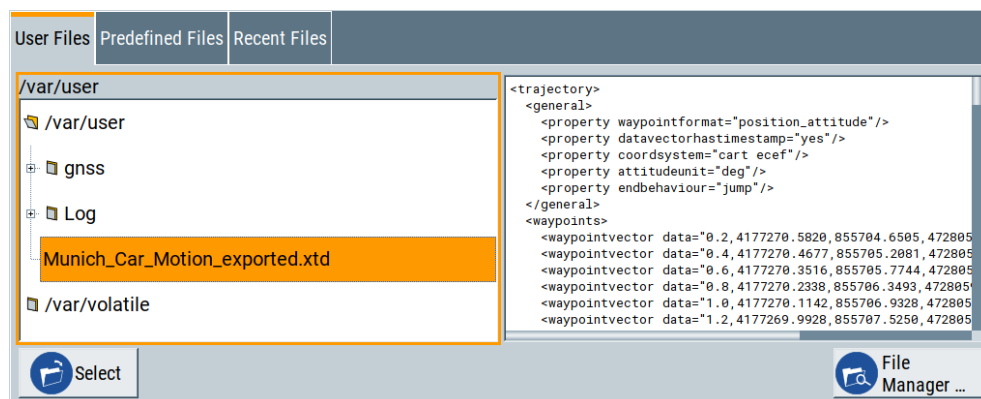

4. To modify the exported file, open the file in the directory `/var/user`. You can use a standard text editor.
5. Save the modified file using the same file extension `*.xtd` to ensure correct execution of the file.

If you need to choose another file extension, waypoint files with file extensions `*.txt`, `*.nmea`, `*.kml` or `*.xtd` are executable on the R&S SMW200A.

5.3.2 Receiver position settings

Access:

1. Select "GNSS" > "Simulation Configuration" > "Receiver".
2. Select "Position" > "Moving".
3. Select "Position Configuration".

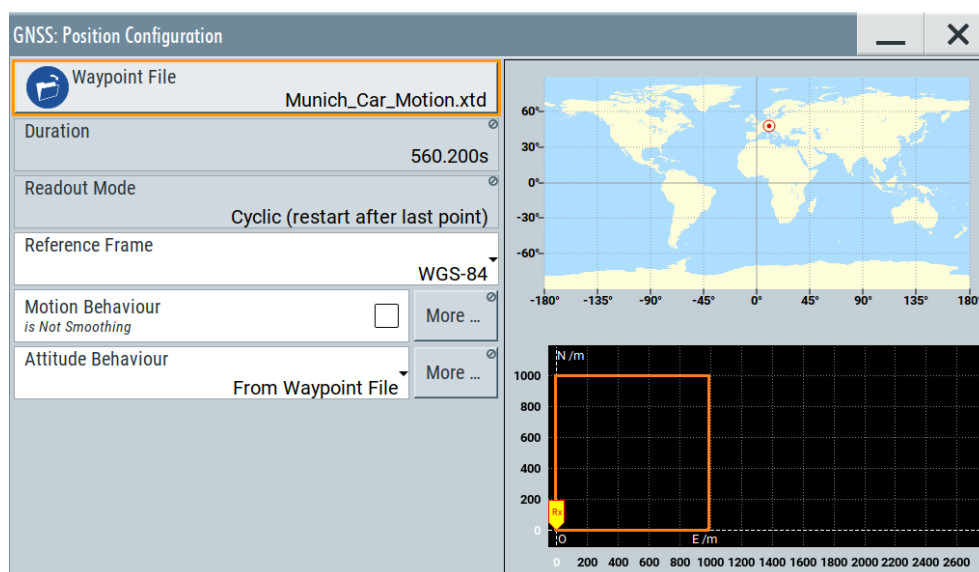

Settings:

Waypoint File.....62
 Trajectory Length/Duration.....63
 Readout Mode.....63
 Reference Frame..... 63

Waypoint File

Selects a predefined or user-defined waypoint files to simulate a moving scenario.

A waypoint file is a description of a moving scenario with possibly attitude coordinates that can have different forms, like, for example, a sequence of positions or vector arc movement. The table below lists supported receiver motion files and their related description.

File type	File extension	Description
Waypoint file	*.txt	See Chapter A.1.1, "Waypoint file format" , on page 650.
XTD	*.xtd	See Chapter A.1.4, "Trajectory description files" , on page 656.
KML	*.kml	See Chapter A.1.4, "Trajectory description files" , on page 656.
NMEA	*.nmea	See Chapter A.1.3, "NMEA files" , on page 656.
TLE	*.tle	Requires R&S SMW-B9F. See TLE .

Note: Simulating high dynamic moving scenarios. High dynamic waypoint files simulating moving scenarios with velocities v higher than 599.9 m/s require a wideband instrument equipped with option R&S SMW-B9F instead of R&S SMW-B9.

If you select a high dynamic waypoint file ($v \geq 600$ m/s) using R&S SMW-B9 option, the firmware displays a settings conflict. The file is rejected. Instead, the R&S SMW200A simulates the movement of the default waypoint file `Munich_Car_Motion.xtd`.

How to: [Chapter 5.3.1, "Configuring a moving receiver"](#), on page 59

Remote command:

`[:SOURce<hw>] :BB:GNSS:RECeiver [:V<st>] :LOCation:WAYPoints:FILE`
on page 387

Trajectory Length/Duration

Displays the trajectory length (in kilometers) and the duration (in seconds) of the waypoint file.

For R&S SMW-B9F and moving files with extension `*.tle`, you can set the duration.

Remote command:

`[:SOURce<hw>] :BB:GNSS:RECeiver [:V<st>] :LOCation:WAYPoints:LENGth?` on page 388

`[:SOURce<hw>] :BB:GNSS:RECeiver [:V<st>] :LOCation:WAYPoints:DURation` on page 387

Readout Mode

Defines the way the waypoint/attitude file is processed.

If `*.xtd` files are used, the "Readout Mode" is retrieved from the file (`<endbehaviour>`) and cannot be changed, see [Chapter A.1.4, "Trajectory description files"](#), on page 656.

- | | |
|--------------|---|
| "Cyclic" | The waypoint file is processed cyclically. Once the last waypoint is reached, file processing starts again from the beginning.

Using this mode is only recommended if the waypoint file describes one of the following: <ul style="list-style-type: none"> • A circle moving scenario • A moving scenario in which the start and the endpoint are close to each other. |
| "One Way" | The file is processed once.
By reaching the end of the file, the last described position is assumed to be a static one. |
| "Round Trip" | By reaching the end of the file, the file is processed backwards. |

Remote command:

`[:SOURce<hw>] :BB:GNSS:RECeiver [:V<st>] :LOCation:WAYPoints:ROMode`
on page 388

Reference Frame

For GNSS receiver, selects the reference frame used to define the receiver coordinates. The transformation between the reference frames is performed automatically.

R&S SMW-K122: For RTK base station, selects the reference frame used to define the receiver or RTK base station coordinates. The transformation between the reference frames is performed automatically.

The following applies:

- $X_{WGS84} = (1 - 0.008 \cdot 10^{-6}) \cdot X_{PZ90} - 0.2041 \cdot 10^{-7} \cdot Y_{PZ90} + 0.1716 \cdot 10^{-7} \cdot Z_{PZ90} - 0.013$
- $Y_{WGS84} = (1 - 0.008 \cdot 10^{-6}) \cdot Y_{PZ90} - 0.2041 \cdot 10^{-7} \cdot X_{PZ90} + 0.1115 \cdot 10^{-7} \cdot Z_{PZ90} + 0.106$
- $Z_{WGS84} = (1 - 0.008 \cdot 10^{-6}) \cdot Z_{PZ90} - 0.1716 \cdot 10^{-7} \cdot X_{PZ90} - 0.1115 \cdot 10^{-7} \cdot Y_{PZ90} + 0.022$

Both reference frames are ECEF frames with a set of associated parameters.

"WGS-84" The World Geodetic System WGS-84 is the reference frame used by GPS.

"PZ 90.11 (GLONASS)"
 Parametry Zemli PZ (Parameters of the Earth) is the reference frame used by GLONASS.

Remote command:

[:SOURce<hw>] :BB:GNSS:RECeiver [:V<st>] :LOCation:COORdinateS :RFRame on page 383

[:SOURce<hw>] :BB:GNSS:RTK:BASE<st> :LOCation:COORdinateS :RFRame on page 396

5.3.3 Motion and attitude configuration and settings

Access:

1. Select "GNSS" > "GNSS Configuration" > "Receiver".
2. Select "Position" > "Moving".
3. Select "Position Configuration" > "Motion Behaviour".



4. Select "More" to open additional motion and attitude configuration settings.

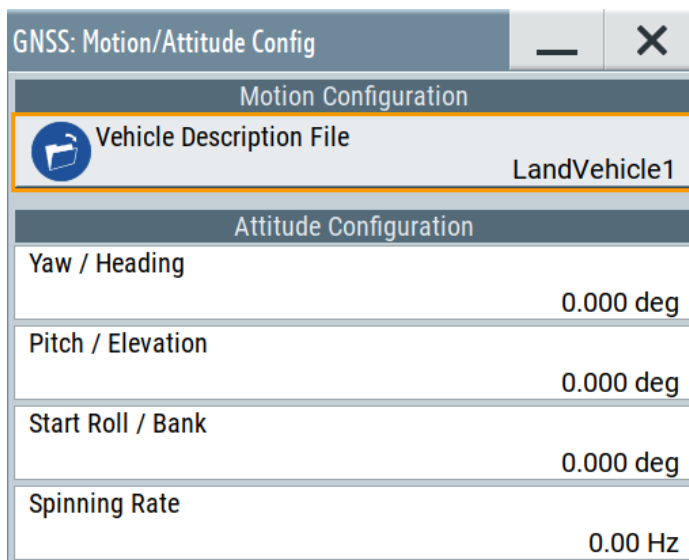

Settings:

Motion Behaviour..... 65
 Attitude Behaviour..... 65
 More..... 66

Vehicle Description File.....	66
Yaw / Heading, Pitch / Elevation, (Start) Roll / Bank.....	67
Spinning Rate.....	67

Motion Behaviour

Enables smooting of the receiver motion. The discrete positions (waypoints) defined in the waypoints file can cause abrupt changes in the movement direction.

The R&S SMW200A provides an internal interpolating algorithm that smooths the movement or the trajectory. This algorithm evaluates the dedicated vehicle description (* .xvd) file, retrieves the velocity vector and the <proximity> value, and inserts waypoints to smooth the trajectory. The resulting movement is more realistic.

Set "Motion Behaviour" > "is Smoothing" and select "More" > "Vehicle Description File ..." to load a * .xvd file. There are predefined files provided, the default file is LandVehicle1.xvd.

Note: An error message is displayed, if the difference between the predicted and the original waypoint for a given time point exceeds the proximity value.

If there is an error:

- Check the speed and acceleration values in the used * .xvd file.
- Check whether these values fit to the flight simulator and the flight scenario.

See also:

- [Chapter A.1, "Movement or motion files"](#), on page 650
- [Chapter A.2, "Vehicle description files"](#), on page 662
- [Chapter H, "List of predefined files"](#), on page 688

Remote command:

```
[ :SOURce<hw> ] :BB:GNSS:RECeiver [ :V<st> ] :LOCation:SMOVement  
on page 388
```

Attitude Behaviour

Sets the attitude characteristics of the receiver.

To define the individual attitude parameters for all attitude behaviors, select "More". This button is available with option R&S SMW-K108.

- | | |
|------------|--|
| "Constant" | Sets the attitude of the receiver as a combination of the "Yaw / Heading", "Pitch / Elevation", "Roll / Bank" values.
The resulting attitude is a constant value. |
| "Spinning" | Enables a constant rate of change of the roll.
See " Spinning Rate " on page 67. |

"From Waypoint File"/"Align to Motion"

Option: R&S SMW-K108

For "Receiver" > "Position" > "Moving", the attitude parameters are extracted from the selected waypoint file. Further settings are not required.

This extraction forces the attitude parameters to motion direction even if the waypoint has attitude information, like, for example, in a *.xtd file with `<property waypointformat="position_attitude">`.

For specific applications like automotive, it is realistic to set the yaw and pitch to the motion direction of the vehicle. The usual body axes angles of a vehicle point to the direction of the velocity vector.

For other applications, however, like aeronautics with a landing plane, this parameter is not useful. AS an example, the nose of the plane is in an upward direction at the time when the plane is moving downwards.

To visualize the effect, select "Receiver" > "Monitor" > "Attitude View", see ["Display"](#) on page 37.

"From Remote"

Option: R&S SMW-K109

For "Receiver" > "Position" > "Remote Control (HIL)", the attitude parameters are set by the received HIL commands. The selection is suspended.

Remote command:

```
[ :SOURce<hw> ] :BB:GNSS:RECeiver [ :V<st> ] :ATTitude [ :BEHaviour ]
```

on page 386

More

Opens a dialog to configure more receiver motion settings or more receiver attitude settings.

More receiver motion settings require the following:

- Receiver "Position" > "Moving"
- Receiver position configuration "Motion Behaviour" > "is Smoothing".

For related settings, see ["Vehicle Description File"](#) on page 66.

More receiver attitude settings require the following:

- Option R&S SMW-K108
- Receiver "Position" > "Static" or "Moving"
- Receiver position configuration "Attitude Behaviour" > "Spinning" or "Constant".

For related settings, see ["Yaw / Heading, Pitch / Elevation, \(Start\) Roll / Bank"](#) on page 67.

Remote command:

n.a.

Vehicle Description File

Opens a standard file-select dialog to select a predefined or user-defined vehicle description file. This dialog lists files with file extension *.xvd, see [Chapter A.2, "Vehicle description files"](#), on page 662.

Remote command:

`[:SOURCE<hw>] :BB:GNSS:RECEIVER[:V<st>]:LOCATION:VEHICLE:FILE`
on page 389

`[:SOURCE<hw>] :BB:GNSS:VEHICLE:CATALOG:PREDEFINED?` on page 389

`[:SOURCE<hw>] :BB:GNSS:VEHICLE:CATALOG:USER?` on page 389

Yaw / Heading, Pitch / Elevation, (Start) Roll / Bank

Option: R&S SMW-K108

Sets the angles of rotation in the corresponding direction, i.e. the rotation around the respective yaw, pitch and roll axes. "Yaw/Heading, Pitch/Elevation, Roll/Bank" are defined relative to the local horizon.

Remote command:

`[:SOURCE<hw>] :BB:GNSS:RECEIVER[:V<st>]:ATTITUDE:YAW` on page 386

`[:SOURCE<hw>] :BB:GNSS:RECEIVER[:V<st>]:ATTITUDE:PITCH` on page 386

`[:SOURCE<hw>] :BB:GNSS:RECEIVER[:V<st>]:ATTITUDE:ROLL` on page 387

Spinning Rate

Option: R&S SMW-K108

Simulates a constant rate of change of the roll, defined with the parameter "Start Roll".

Remote command:

`[:SOURCE<hw>] :BB:GNSS:RECEIVER[:V<st>]:ATTITUDE:SPIN:RATE`
on page 387

6 Satellite constellation

This section addresses basic satellite constellation characteristics including multi-satellite signals, multi-GNSS signals and satellite selection within the constellation.

Multi-satellite GNSS signal

The default multi-satellite single GNSS system constellation is the realistic constellation in a theoretical unobscured environment of a static receiver at a specific location. It includes all visible GNSS satellites, where a line-of-sight (LOS) situation is assumed.

Example: Single GNSS satellite constellations for fully equipped R&S SMW200A

For a fully equipped R&S SMW200A, [Table 6-1](#) provides an overview on the default satellite constellation comprising visible, present and excluded satellites.

Table 6-1: Single GNSS satellite default constellations: Visible, present and excluded satellites

GNSS/SBAS	Visible	Present	Excluded	Present (max.)
GPS	11	31	6	37
Galileo	8	29	7	36
GLONASS	9	24	0	24
BeiDou	12	34	29	63
QZSS	0	3	4	7
NavIC	3	6	8	14
EGNOS	2	2	4	6
WAAS	0	3	2	5
MSAS	0	2	0	2
GAGAN	1	2	0	2

Multi-GNSS signal

The default single GNSS system configuration can be extended to support receiver tests with complex test signal. You can generate mixed signal comprising satellites of different GNSS systems or signals spread with different codes, possibly also modulated on the other frequency.

See [Chapter 6.1, "Systems and signals settings"](#), on page 69.

Satellite selection

If your test case requires a mixed GNSS signal with predefined minimum and maximum number of satellites per GNSS system, you can set these limits per GNSS system, too.

Moreover, you can adjust the SV handover criteria and thus define when the satellite's constellation is updated and satellites are exchanged. Satellites exchange is optimized to fulfill the selected criteria; considered are all available satellites, regardless of the GNSS system but obeying the limits for maximum and minimum number of satellites.

Visible satellites can be deactivated or reactivated on-the-fly. Current constellation and an overview of the number of active satellites per GNSS system are displayed.

See [Chapter 6.2, "Satellites settings"](#), on page 73.

Dynamic monitor

You can observe the real-world situation of disappearance and reappearance of satellites in real time on the build-in simulation monitor. The monitor is also a dynamic display of several parameters like HDOP and the PDOP.

See [Chapter 3.3, "Simulation monitor"](#), on page 36.

6.1 Systems and signals settings

Access:

1. Select "GNSS" > "GNSS Configuration" > "Systems & Signals".
2. In the dialog, activate frequency bands, systems and their signals. Systems mean global navigation satellite systems (GNSS), regional navigation satellite systems (RNSS) and satellite-based augmentation systems (SBAS).

Systems & Signals		Time	Receiver	Satellites	Atmosphere	Output Streams
	System	L1 Band		L2 Band		L5 Band
		<input checked="" type="checkbox"/>		<input checked="" type="checkbox"/>		<input checked="" type="checkbox"/>
GNSS	<input checked="" type="checkbox"/> GPS	C/A,PL1C		C/A,PL2C		L5
	<input checked="" type="checkbox"/> Galileo	E1 OS		E6		E5a,E5b
	<input checked="" type="checkbox"/> GLONASS	C/A,CDMA L1		C/A,CDMA L2		CDMA L3
	<input checked="" type="checkbox"/> BeiDou	B1I,B1C		B3I		B2I,B2a
RNSS	<input checked="" type="checkbox"/> QZSS	C/A,L1C		L2C		L5
	<input checked="" type="checkbox"/> NavIC					SPS
SBAS	<input type="checkbox"/> EGNOS	C/A				Exp L5
	<input type="checkbox"/> WAAS	C/A				Exp L5
	<input type="checkbox"/> MSAS	C/A				
	<input type="checkbox"/> GAGAN	C/A				

The dialog displays the configuration for a wideband instrument (R&S SMW-B9), equipped with triple-frequency option. In this dialog you can activate signals of L1, L2 and L3 bands simultaneously. See also ["L# Band"](#) on page 70.

Settings:

System..... 70
 L# Band..... 70
 Signals..... 71

System

Defines the navigation systems that are part of the system configuration, see [Chapter 6.2, "Satellites settings"](#), on page 73.

The available global, regional and satellite-based navigation and augmentation systems depend on the installed options.

Note: At least one system is always enabled. Switching off a single enabled GNSS is not possible, a warning message is displayed to indicate the situation.

Remote command:

[:SOURce<hw>] :BB:GNSS:SYSTem:GPS [:STATe] on page 364
 (etc. for the other GNSS systems)

L# Band

Defines the used frequency band "L1/2/5 Band". The satellite signals are modulated on the carrier frequencies as defined for the corresponding frequency band and system.

Table 6-2: Carrier frequencies

System	RF band (signals)	Carrier freq. (MHz)	Required option
GPS	L1 (C/A, P, L1C, P(Y)-Noise, M-Noise)	1575.42	R&S SMW-K44/K128
	L2 (C/A, P, L2C, P(Y)-Noise, M-Noise)	1227.6	R&S SMW-K98/K128
	L5 (L5)	1176.45	R&S SMW-K98
Galileo	L1 (E1, E1 PRS-Noise)	1575.42	R&S SMW-K66/K128
	L2 (E6, E6 PRS-Noise)	1278.75	R&S SMW-K66/K128
	L5 (E5a)	1176.45	R&S SMW-K66
	L5 (E5b)	1207.14	R&S SMW-K66
GLONASS	L1 (C/A)	1602	R&S SMW-K94
	L1 (CDMA L1)	1600.995	R&S SMW-B9 and -K123
	L2 (C/A)	1246	R&S SMW-K94
	L2 (CDMA L2)	1248.06	R&S SMW-B9 and -K123
	L5 (CDMA L3)	1202.025	R&S SMW-B9 and -K123
BeiDou	L1 (B1I)	1561.098	R&S SMW-K107
	L1 (B1C)	1575.42	R&S SMW-K132
	L2 (B3I)	1268.52	R&S SMW-K132
	L5 (B2I)	1207.14	R&S SMW-K107
	L5 (B2a)	1176.45	R&S SMW-K132
	L5 (B2b)	1207.14	R&S SMW-K132
QZSS	L1 (C/A, L1C)	1575.42	R&S SMW-K106
	L2 (L2C)	1227.6	R&S SMW-K106
	L5 (L5)	1176.45	R&S SMW-K106

System	RF band (signals)	Carrier freq. (MHz)	Required option
NavIC	L5 (SPS)	1176.45	R&S SMW-K97
SBAS	L1 (C/A)	1575.42	R&S SMW-K106
	L5 (Exp L5)	1176.45	R&S SMW-K106

Note: At least one frequency band is always enabled. Switching off all frequency bands is not possible. A warning message is displayed to indicate the situation. Assuming more than one frequency band and GNSS system enabled: If switching off a GNSS system implies, that an enabled frequency band carries no signals, this frequency band is switched off automatically.

Switching from L1 to L2 or to L5 disables the systems defined only for the L1 band. Switching the other way around does not activate the systems that have been enabled before in the L1 band. For any frequency band, activated per default is the first supported and available system in the list of GNSS systems.

Equipped as a wideband instrument (R&S SMW-B9), you can also enable multiple bands simultaneously. The R&S SMW200A selects feasible frequency band combinations and distributes the signals among the available baseband resources. It also routes the generated streams to the output conductors automatically. Signal routing can be changed later.

For more information, see [Chapter 15, "Advanced GNSS scenarios"](#), on page 267.

Remote command:

`[:SOURce<hw>] :BB:GNSS:L1Band [:STATe]` on page 363

`[:SOURce<hw>] :BB:GNSS:L2Band [:STATe]` on page 363

`[:SOURce<hw>] :BB:GNSS:L5Band [:STATe]` on page 363

Signals

Enables the signals per system.

The enabled signals are activated automatically for each SV belonging to the GNSS system. To redefine the signals used by a particular satellite (SV), select "GNSS Configuration" > "Satellites" > "GNSS System" > "SV ID#" > "SV Config" > "Signal" > "Signal State" on page 89.

Note: At least one GNSS, one frequency band and one signal are always active. If switching one of them off, a message displays an error.

See also ["System"](#) on page 70 and ["L# Band"](#) on page 70.

"None" All signals of a GNSS system are disabled assuming, that the GNSS system itself is disabled. All parameters of the GNSS system are disabled, too.
"Signals = None" implies [System](#) > "State = Off".

"C/A, P, L1C, P(Y)-Noise, M-Noise, E1 OS, E1 PRS-Noise, B1I, B1C, L2C, E6, E6 PRS-Noise, B3I, L5, E5a, E5b, B2I, B2a, B2b, SPS, Exp L5"

Table 6-3: Overview of the supported signals

Band	System	Signal	Minimum required option
L1	GPS	C/A, P L1C P(Y)-Noise ¹⁾ M-Noise ¹⁾	R&S SMW-K44 R&S SMW-K98 R&S SMW-K128 R&S SMW-K128
	Galileo	E1 OS E1 PRS-Noise ¹⁾	R&S SMW-K66 R&S SMW-K128
	GLONASS	C/A CDMA L1 ²⁾	R&S SMW-K94 R&S SMW-B9 and -K123
	BeiDou	B1I B1C	R&S SMW-K107 R&S SMW-K132
	QZSS	C/A, L1C	R&S SMW-K106
	SBAS	C/A	R&S SMW-K106
L2	GPS	C/A P, L2C P(Y)-Noise ¹⁾ M-Noise ¹⁾	R&S SMW-K44 R&S SMW-K98 R&S SMW-K128 R&S SMW-K128
	Galileo	E6 E6 PRS-Noise ¹⁾	R&S SMW-K66 R&S SMW-K128
	GLONASS	C/A CDMA L2 ²⁾	R&S SMW-K94 R&S SMW-B9 and -K123
	BeiDou	B3I	R&S SMW-K132
	QZSS	L2C	R&S SMW-K106
L5	GPS	L5	R&S SMW-K98
	Galileo	E5a, E5b	R&S SMW-K66
	GLONASS	CDMA L3	R&S SMW-B9 and -K123
	BeiDou	B2I B2a B2b ³⁾	R&S SMW-K107 R&S SMW-K132 R&S SMW-K132
	QZSS	L5	R&S SMW-K106
	NavIC	SPS	R&S SMW-K97
	SBAS	Exp L5 ⁴⁾	R&S SMW-K106

¹⁾ The signals GPS M-Noise/P(Y)-Noise (L1/L2), Galileo PRS-Noise (E1/E6) are for experimental use only. These signals contain arbitrary. Use them for spectral interferer testing. These signals are not useful

for position fix calculation and do not comply with any ICD specifications.

You cannot generate GPS P signal and GPS P(Y)-Noise at the same time. A warning message displays failure and that one of these signals is deactivated.

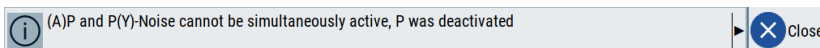

²⁾ The modernized GLONASS signals CDMA L1 and CDMA L2 are for experimental use only. Any compliance with GLONASS ICD CDMA open service navigation signal in L1 frequency band or GLONASS ICD CDMA open service navigation signal in L2 frequency band is not guaranteed. See also [Table 2-7](#).

³⁾ BeiDou B2b_I I-component of the B2b OS signal for space vehicles PRN 6 to PRN 58. Q-components of AS signals including B2b_Q are not supported, see also [Table 2-8](#).

⁴⁾ SBAS "Exp L5" signals are for experimental use only and do not comply with SBAS interface control document (ICD) specifications, see also [Table 2-11](#).

Remote command:

```
[ :SOURce<hw> ] :BB:GNSS:SYSTEM:GPS:SIGNal:L1Band:CA [ :STATe ]
```

on page 366

```
[ :SOURce<hw> ] :BB:GNSS:SYSTEM:GPS:SIGNal:L1Band:P [ :STATe ]
```

on page 366

(etc. for the other GNSS systems)

6.2 Satellites settings

Access:

1. Activate the GNSS system for that you want to configure satellites settings.
See "[System](#)" on page 70.

2. Select "GNSS" > "Simulation Configuration" > "Satellites".

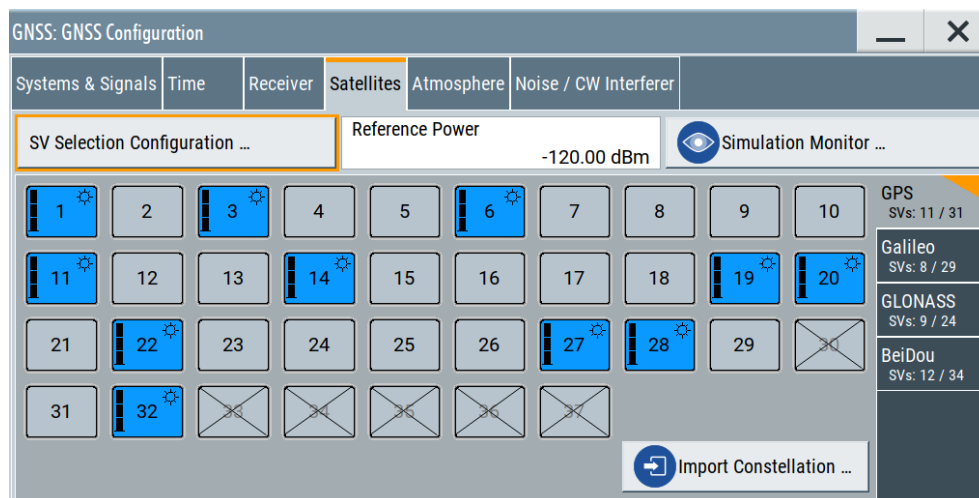

The tab provides settings to configure satellite selection, to configure the reference power and to access the simulation monitor. Also, it provides settings to configure individual space vehicles (SV) of the satellite constellation for each activated GNSS system.

To configure satellite selection, like selection criteria, minimum and maximum number of SVs of a satellite constellation, see [Chapter 6.3, "Space vehicle selection configuration"](#), on page 77.

To configure individual SV settings, see [Chapter 7, "Space vehicle configuration"](#), on page 82.

Understanding satellite constellation characteristics

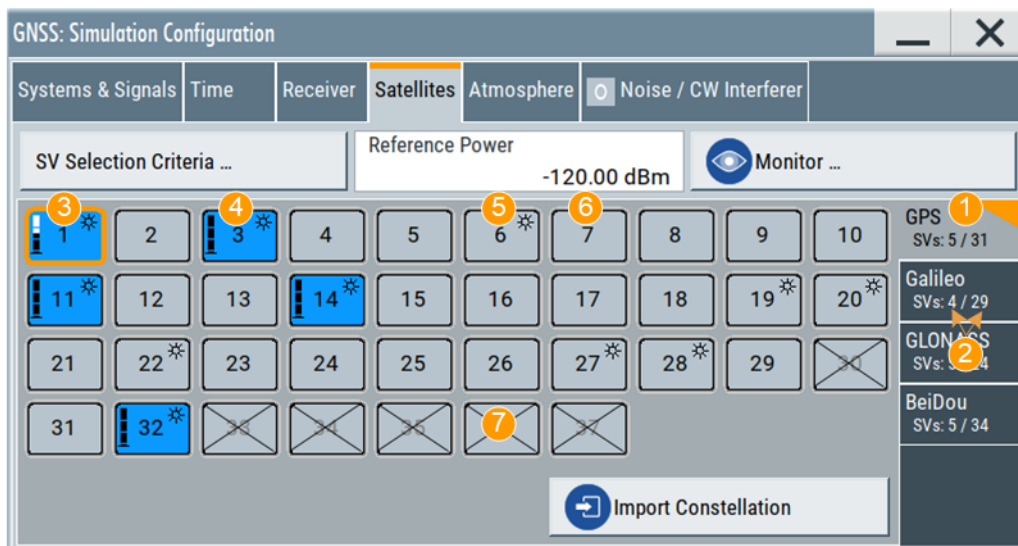

Figure 6-1: Satellite constellation per GNSS system

- 1 = Activated GNSS systems
- 2 = Number of active and available SVs per GNSS system
- 3 = Visible and active SV that uses reduced power level

- 4 = Visible and active SV, full power level
- 5 = Visible and inactive SV ("Satellite's Constellation, SV ID" on page 75 = Off)
- 6 = Not visible and inactive SV
- 7 = Excluded from the constellation (Present in Constellation = "Off")

Active and visible satellites are indicated with blue color.

Settings:

- SV Selection Configuration..... 75
- Reference Power..... 75
- Simulation Monitor..... 75
- Satellite's Constellation, SV ID..... 75
 - L State (SV ID)..... 76
 - L Power Offset..... 77
 - L SV Config..... 77
- Import Constellation..... 77

SV Selection Configuration

Accesses a dialog to configure satellite selection criteria and minimum and maximum number of satellites of the satellite constellation. See Chapter 6.3, "Space vehicle selection configuration", on page 77.

Reference Power

Sets the power level that is used as a reference for the calculation of the power level of the satellites.

See "About satellite's (SV) power calculation" on page 82.

Remote command:

[:SOURce<hw>] :BB:GNSS:POWer:REFEreNce on page 459

Simulation Monitor

Accesses the "Simulation Monitor" dialog for real-time display of the most important parameters.

These parameters are, for example, the current satellite constellation with SV states and position, receiver position or movement trajectory and received satellite power.

See Chapter 3.3, "Simulation monitor", on page 36.

Satellite's Constellation, SV ID

Indicates the SV IDs included in the current constellation.

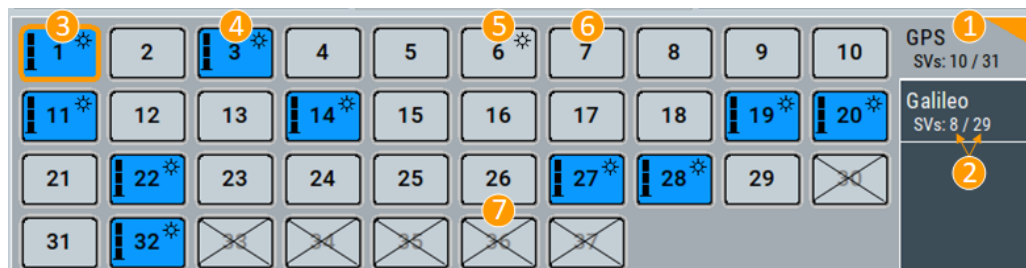

- 1 = Enabled GNSS systems
- 2 = Number of active and available SVs per GNSS system
- 3 = Visible and active SV that uses reduced power level
- 4 = Visible and active SV, full power level
- 5 = Visible and inactive SV ("[Satellite's Constellation, SV ID](#)" on page 75 = Off)
- 6 = Not visible and inactive SV
- 7 = Excluded from the constellation ([Present in Constellation](#) = "Off")

The information is color-coded. Icons provide further information:

- Blue: active SV ID
- Gray: Inactive SV ID
- Sun: Visible SV ID
- Cross out: SV ID is excluded from the constellation, for example if "SV ID > SV Config" > [Present in Constellation](#) > "Off"
- Power bar: Reduced height indicates that the signal of the SV ID is transmitted with less power than the value indicated as "Configurable Nav. Message".
The height of the power bar reflects enabled "Power Offset", "Power Path-Loss" and "Power Offset" of the echoes.

The blocks are interactive. Select an SV ID to access further settings for changing its state, enabling power offset of configuring the orbit simulation and navigation message parameters.

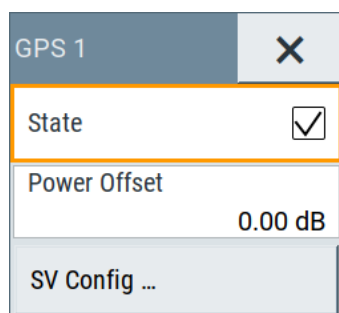

Remote command:

[\[:SOURCE<hw>\]:BB:GNSS:SVID:GPS:LIST:ALL?](#) on page 444

[\[:SOURCE<hw>\]:BB:GNSS:SVID:GPS:LIST\[:VALID\]?](#) on page 444

[\[:SOURCE<hw>\]:BB:GNSS:SVID<ch>:GPS:HEALTHY](#) on page 445

[\[:SOURCE<hw>\]:BB:GNSS:SVID<ch>:GPS:VISIBILITY:STATE?](#) on page 446

(etc. for the other GNSS systems)

State (SV ID) ← [Satellite's Constellation, SV ID](#)

Changes the SV ID state on-the-fly.

Per default, only visible satellites can be included in the constellation. SV ID for that [Present in Constellation](#) > "Off" cannot be activated.

Tip: Pressing the ON/OFF TOGGLE key has the same effect on the selected SV ID.

To enable any SV ID, set "Satellites" > "SV Selection Configuration" > "Selection Mode" > "Manual".

Remote command:

[\[:SOURCE<hw>\]:BB:GNSS:SVID<ch>:GPS:STATE](#) on page 459

(etc. for the other GNSS systems)

Power Offset ← Satellite's Constellation, SV ID

Reduces the signal of the selected SV ID by the defined value.

This is a global power offset parameter for a satellite. It affects the power level of all signal components of a given satellite.

See ["About satellite's \(SV\) power calculation"](#) on page 82. Power changes are applied on-the-fly.

Remote command:

[:SOURce<hw>] :BB:GNSS:SVID<ch>:GPS:POWer:OFFSet on page 460
(etc. for the other GNSS systems)

SV Config ← Satellite's Constellation, SV ID

Access a dialog with further settings for configuring the orbit simulation and navigation message parameters.

See:

- [Chapter 7, "Space vehicle configuration"](#), on page 82
- [Chapter 13, "Perturbations and errors simulation"](#), on page 192

Import Constellation

Opens the "Import Constellation" dialog that is a standard "File Select" dialog.

You can select, for example, almanac or RINEX files. See also:

- ["File formats"](#) on page 308.
- [Chapter 18.1, "Import constellation settings"](#), on page 310.

6.3 Space vehicle selection configuration

Access:

1. Select "GNSS" > "Simulation Configuration" > "Satellites".
2. Select "SV Selection Configuration".

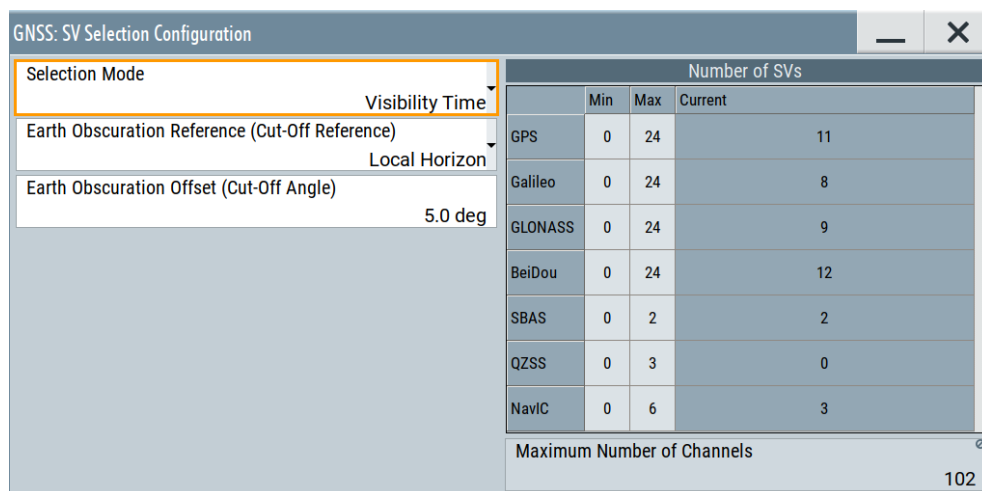

The dialog provides settings to configure satellite visibility and handover criteria. Also, you can set the minimum and maximum number of activated satellites per GNSS system.

The maximum number of satellites and maximum number of channels depends on the installed options, see [Table 2-3](#). Selection criteria are not available for "Test Mode" > "Tracking", the satellite selection is manual.

Settings:

Selection Mode	78
Earth Obscuration Reference (Cut-Off Reference)	79
Earth Obscuration Offset (Cut-Off Angle)	81
Number of SVs	81
Maximum Number of Channels/Total Number of Available Channels	81

Selection Mode

Sets the mode for space vehicle (SV) selection to define the overall satellite constellation. Also, applies rules for satellite handover.

"Visibility Time"

Constellation consists of satellites that are likely to be visible for the longest time.

"Elevation Angle"

Selected are the satellites with the highest elevation.

For defining the elevation, see ["Earth Obscuration Reference \(Cut-Off Reference\)"](#) on page 79 and ["Earth Obscuration Offset \(Cut-Off Angle\)"](#) on page 81.

"DOP"

Selects a satellite constellation which provides good dilution of precision (DOP) values at simulation start.

The DOP-based satellite selection implies the following:

- The selection prefers satellites that are visible for more than five minutes.
- The final satellite constellation results from optimizations of sub-constellations for all active GNSS systems. These optimizations imply optimized independent geometric conditions for each individual GNSS system.
- During runtime, the selection keeps active satellites as long as possible in the constellation, even if their DOP values degrade. Keeping these satellites ensures constant tracking.
- When active satellites sink or new satellites rise and free channels are available, the selection adds new satellites to the constellation based on their DOP value.

"Adaptive DOP"

Selects a satellite constellation which provides good dilution of precision (DOP) values at simulation start and during runtime.

The adaptive DOP-based satellite selection implies the following:

- At simulation start, the selection is similar to the DOP-based selection.
- During runtime, the selection adds or removes active satellites, if the overall position (3D) dilution of precision (PDOP) value of the satellite constellation is lower than 2.0.
- Adding or removing active satellites implies a gradual satellite switching process that is independent over all active GNSS systems. The switching process has some constraints and starts only, if the PDOP significantly improves.

"Manual"

Manual selection as in the satellite constellation.

Automatic satellite selection is deactivated. Change the state of an SV ID to change the satellite constellation manually. You can activate any SV ID, including invisible satellites.

This mode is fixed and suspended for "Test Mode" > "Tracking", see [Chapter 11, "Tracking mode"](#), on page 181.

Remote command:

[:SOURCE<hw>] :BB:GNSS:SV:SELECTION:MODE on page 441

Earth Obscuration Reference (Cut-Off Reference)

Selects how the behavior of earth obscuration is defined. The behavior also defines the horizon, which is the reference line for applying the elevation mask angle, see [Figure 6-2](#).

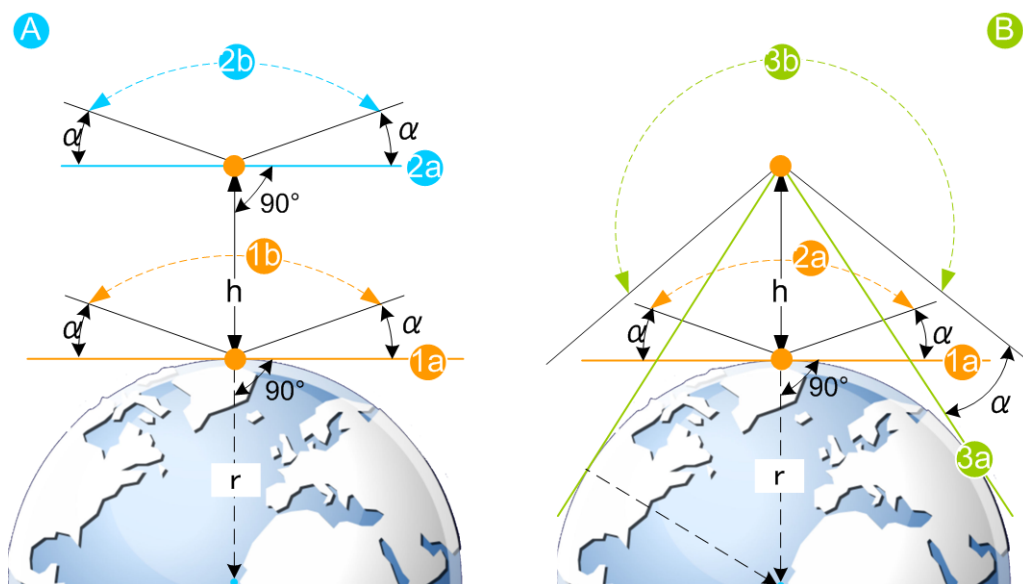

Figure 6-2: Impact of the Earth Obscuration Reference on the area of visible satellites (XY cut)

A = "Local Horizon"

B = "Earth Tangent"

α = "Earth Obscuration Offset" applied relative to the selected horizon

- h = "Receiver" > "Positioning Configuration" > "Altitude"
- r = Nadir (an imaginary vertical line that connects the location and the center of the earth)
- 1a = Horizon line for "Altitude" = "0 m" (identical for both elevation mask types)
- 1b = Area of visible satellites (identical for both elevation mask types)
- 2a = Horizon line for "Altitude" = "h, km"; the horizon is parallel to the horizon with "Altitude" = "0 m"
- 2b = Area of visible satellites
- 3a = Horizon lines for "Altitude" = "h, km"; the horizon lines are tangential to the earth surface
- 3b = Area of visible satellites

Use the "Signal Monitor" view to observe the current satellite constellation. The figures in Table 6-4 show the satellite constellations as seen by receiver at an "Altitude" = "200 km" with "Earth Obscuration Offset" = "5°". The number of active satellites changes because of the different elevation mask types.

Table 6-4: Impact of the Earth Obscuration Reference on the visible satellites

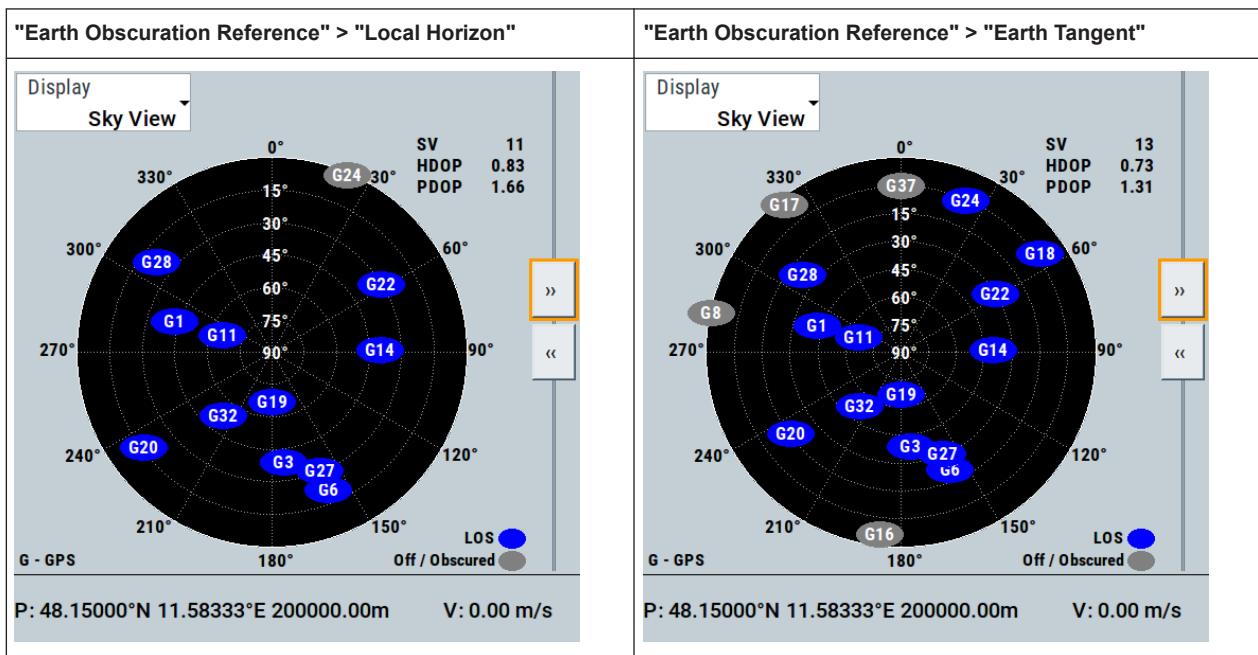

"Local Horizon"

The horizon is a horizontal plane that is perpendicular to the nadir. For locations with attitudes above the sea level, the horizontal plane is parallel shifted at the selected attitude.

The "Local Horizon" type is suitable, if you simulate receivers at low altitude. For example, for pedestrian and automotive application.

"Earth Tangent"

The horizon is the surface of a right circular cone, where:

- The vertex of the cone is at the receiver position.
- The cone axis is along the nadir.
- The cone surface is made of lines that are tangential to the earth surface.

The "Earth Tangent" type is suitable, if you simulate receivers at higher altitude, where satellites with negative elevations are also visible. A typical example is a GNSS receiver mounted on low earth orbit (LEO) object.

Remote command:

`[:SOURCE<hw>] :BB:GNSS:SV:SELECTION:EOBScuration:REFerence`
on page 441

Earth Obscuration Offset (Cut-Off Angle)

Sets the elevation mask angle of the satellite. The angle is applied relative to the selected horizon, see "[Earth Obscuration Reference \(Cut-Off Reference\)](#)" on page 79.

Satellites that are below the elevation mask angle are obscured. They are invisible for the GNSS receiver at the selected location. Obscured satellites are displayed in the "Signal Monitor" view but not simulated. A test receiver cannot use obscured satellites for determining its position; it has to search for satellites with better visibility. See the figures in [Table 6-4](#).

To ensure proper signal analysis, set the parameter "Earth Obscuration Offset" to the elevation mask of the GNSS receiver under test.

Remote command:

`[:SOURCE<hw>] :BB:GNSS:SV:SELECTION:EOBScuration:ANGLE` on page 442

Number of SVs

Provides settings in a table to configure and monitor the number of satellites per GNSS system.

"Min"	Minimum number of activated satellites in the satellite constellation per GNSS system.
"Max"	Minimum number of activated satellites in the satellite constellation per GNSS system.
"Current"	Displays the number of active satellites in the satellite constellation per GNSS system. The value equals the value on the side tab of the "Satellites" dialog, see Figure 6-1 .

Remote command:

`[:SOURCE<hw>] :BB:GNSS:SV:SELECTION:GPS:MIN` on page 443

`[:SOURCE<hw>] :BB:GNSS:SV:SELECTION:GPS:MAX` on page 443

`[:SOURCE<hw>] :BB:GNSS:SV:SELECTION:GPS:ACTIVE?` on page 443

`[:SOURCE<hw>] :BB:GNSS:SV:SELECTION:GPS:AVAILABLE?` on page 443

(etc. for the other GNSS systems)

Maximum Number of Channels/Total Number of Available Channels

Requires R&S SMW-B9.

Displays the maximum or total number of channels. Editing the parameter requires "Mode" > "GNSS Advanced".

You can simulate up to 612 GNSS channels. The number depends on the simulation capacity, see [Chapter G, "Channel budget"](#), on page 682.

Remote command:

`[:SOURCE<hw>] :BB:GNSS:SV:SELECTION:CHANNELS:MAX` on page 442

7 Space vehicle configuration

About satellite's (SV) power calculation

In R&S SMW200A, you define the power level of the individual satellites or their signals and the power level at the RF output is calculated automatically. All power levels are set **relative to a configurable reference level**. By changing this level you boost or decrease the signal power at the R&S SMW200A outputs, while maintaining the power ratio between the satellites, their signals and, if enabled, the multi-path echoes.

Absolute SV power

The absolute SV power for a given signal $P_{SV,signal}$ is calculated as follows:

$P_{SV,signal} = P_{Ref} + P_{SV,offset} + P_{Signal,offset} + P_{PathLoss} + P_{AntPat}$, where:

- P_{Ref} is the reference power level, as set with the parameter [Reference Power](#)
- $P_{SV,offset}$ is the global power offset of the satellite, as set with the parameter [Power Offset](#)
- $P_{Signal,offset}$ is signal-specific power offset, as set with the parameter [Signal Power Offset](#)
The value reflects the differences between the signals and the frequency bands.
- $P_{PathLoss}$ is the free space path-loss over the satellite to receiver distance (range), included if [Add Power Path-Loss](#) > "On".
See "[Free space path-loss power](#)" on page 82.
- P_{AntPat} is the power gain of the antenna, calculated automatically, depending on the selected body mask
See [Chapter 8.6, "Antenna and body mask settings"](#), on page 125.

Free space path-loss power

$P_{PathLoss}$ is the free space path-loss over the satellite to receiver distance (range), calculated as follows:

$P_{PathLoss} = 20\log_{10}(R_0/R)$, where:

- $R_0 = \sqrt{(R_{Orbit,SV}^2 - r^2)}$
 R_0 is the reference range, equal to the range of a receiver on the ground to an SV_0 at 90° elevation
- R is the receiver to satellite range.

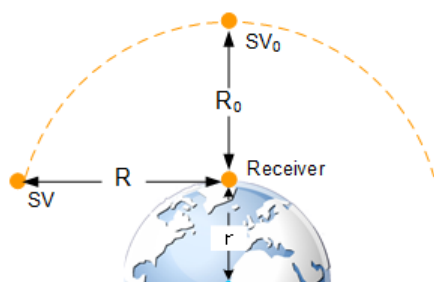

Figure 7-1: Free space path-loss calculation

- SV₀ = Reference space vehicle
- R₀ = Reference range
- SV = Space vehicle
- R = Range between the SV and the receiver
- r = Earth's radius

Absolute multi-path echo power

The absolute power of an echo for a given signal P_{SV,echo} is calculated as follows:

$$P_{SV,echo} = P_{SV,signal} + P_{Echo,signal}, \text{ where:}$$

- P_{SV,signal} is the absolute satellite's power
- P_{Echo,signal} is the power offset per echo, as set with the parameter [Power Offset](#).



Satellite constellation recalculation

If you change settings of the space vehicle configuration, e.g., simulated orbit or simulated clock settings, the satellite constellation is recalculated accordingly. Recalculation interrupts the simulation of the satellite constellation as long as the recalculation process takes.

During longer calculation times, the R&S SMW200A shows a "Busy" state.

Settings:

- [Power settings](#).....83
- [Modulation control settings](#)..... 88
- [Simulated orbit and orbit perturbation settings](#).....93
- [Simulated clock settings](#).....102

7.1 Power settings

Access:

1. Select "GNSS" > "GNSS Configuration" > "Satellites".
2. Set the "Reference Power".

All power values are set relative to the reference power.

3. Select the GNSS system for that you want to change the satellite's power settings, for example GPS.
4. Select "SV#" > "SV Config".
5. In the "SV Configuration" dialog, select "Signals Configuration".
6. Select "Add Power Path-Loss" > "On" to account for the free-space attenuation.
7. Set a "Power Offset" to reduce further the signal power of the satellite.
8. In dual-band or multi-signal configurations, set a "Signal Power Offset" to account for the power relation between the signals.
9. To apply the power settings of the current satellite to other SV ID, select for example "SV-ID" = "11" and "Copy Power Settings To".

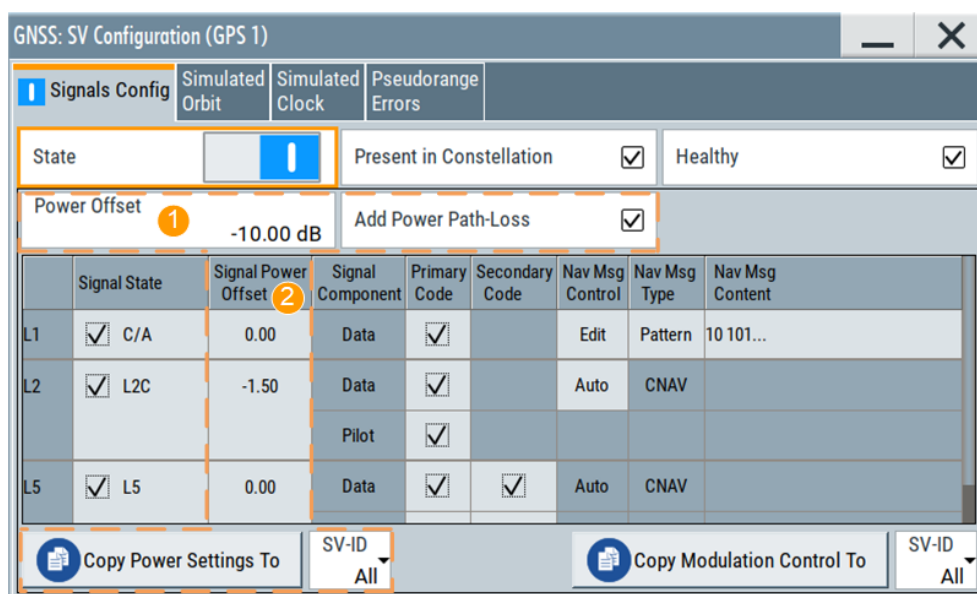

Figure 7-2: Power settings: understanding the displayed information

- 1 = Decreases the SV signal power and thus the power of all signals of this SV. SV "Power Offset" is set relative to the [Reference Power](#).
- 2 = Boosts or decreases the power of the individual signal components. Power offsets are set relative to the [Reference Power](#) + "Power Offset".

Available power settings depend on the GNSS system and selected RF band. For information on how these settings affect the SV power, see ["About satellite's \(SV\) power calculation"](#) on page 82.

10. To simulate multipath effects:
 - For more information, see [Chapter 8.7.6, "Static multipath"](#), on page 148.
 - a) Select "GNSS Configuration" > "Receiver" > "Environmental Model" > "Static Multipath".
 - b) Select "Environmental Model"
 - c) Set for example: "Number of Echoes" = "1", "Echo 1" > "Init. Code Phase" = "300 m", "Power Offset" = "-10 dB".

- Select "GNSS" > "Simulation Monitor" > "Satellites" > "Power View" to observe the power levels of all satellites at a glance.

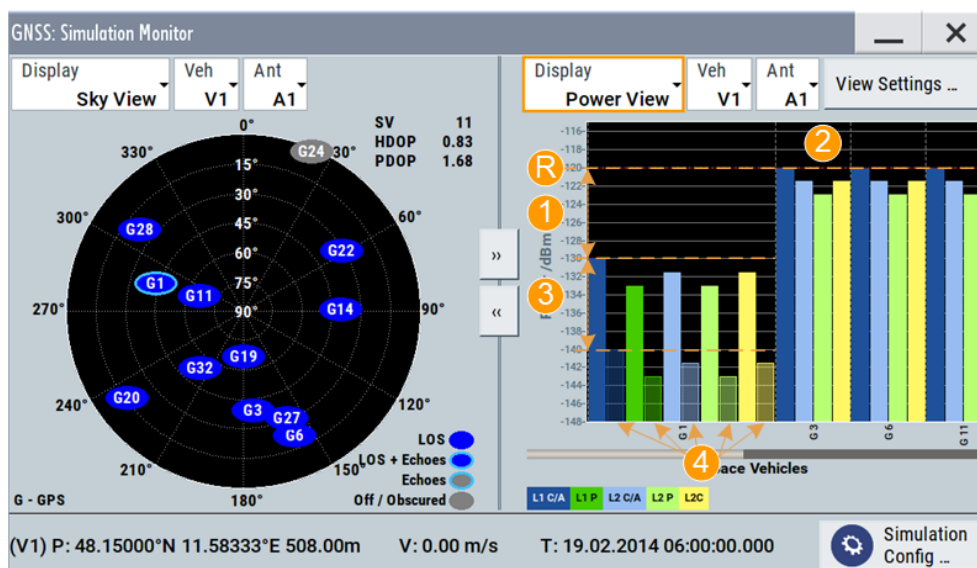

Figure 7-3: Power View: understanding the displayed information

- R = Reference Power= -120 dB
- 1 = "SV ID 1" > "Power Offset" = "-10 dB"
- 2 = "Signal Power Offsets", e.g. L1 C/A = 0 dB and L1 P = - 3dB; the same power relation is observed in SVs with or without power offset and for the multipath echoes
- 3 = "SV ID 1" > "Echo 1" > "Power Offset" = "-10 dB"
- 4 = One echo per signal ("Number of Echoes" = "1"); displayed for "View Settings" > "Echoes" = "On"

- Load and enable body mask files to visualize the effect of antennas on the power. For more information, see [Chapter 8.6, "Antenna and body mask settings"](#), on page 125.

The remote commands required to define these settings are described in:

- [Chapter 22.12, "Signals and power configuration per satellite"](#), on page 448
- [Chapter 22.8, "Static multipath configuration"](#), on page 415.

Settings:

State (SV ID).....	85
Present in Constellation.....	86
Healthy.....	86
Power Offset.....	86
Add Power Path-Loss.....	87
Frequency Number.....	87
SV signal configuration table.....	87
└ Signal Power Offset.....	87
Copy Power Settings to,SV-ID.....	87

State (SV ID)

Changes the SV ID state on-the-fly.

Per default, only visible satellites can be included in the constellation. SV ID for that [Present in Constellation](#) > "Off" cannot be activated.

Tip: Pressing the ON/OFF TOGGLE key has the same effect on the selected SV ID.

To enable any SV ID, set "Satellites" > "SV Selection Configuration" > "Selection Mode" > "Manual".

Remote command:

[:SOURce<hw>] :BB:GNSS:SVID<ch>:GPS:STATe on page 459
(etc. for the other GNSS systems)

Present in Constellation

If disabled, the SV ID is excluded from the current constellation. The SV ID is automatically deactivated ("SV ID" > "State" = "Off").

In the "Satellites" dialog, SV IDs that are excluded from the constellation are displayed in gray color and are crossed out.

To reactivate such satellite, set "Present in Constellation" > "On" and enable it ("State" > "On")

Remote command:

[:SOURce<hw>] :BB:GNSS:SVID<ch>:GPS:PRESent on page 459
(etc. for the other GNSS systems)

Healthy

Defines if the SV ID is healthy or not. A warning symbol indicates an unhealthy satellite.

The healthy state reflects the value of the corresponding healthy flag in the navigation message. The healthy flag and the healthy state are interdependent; changing one of them changes the other.

See:

- [GPS > Additional Data](#) > "SV Health" and "L1/L2/L5 Health"
- [GLONASS > Additional Data](#) > "SV Health"
- [Galileo > Additional Data](#) > "E1B_{DVS}/E5b_{DVS}/E1B_{HS}/E5b_{HS}"
- [BeiDou > Additional Data](#) > "SV Health"
- [QZSS > Additional Data](#) > "SV Health"

Remote command:

[:SOURce<hw>] :BB:GNSS:SVID<ch>:GPS:HEALthy on page 445
(etc. for the other GNSS systems)

Power Offset

Reduces the signal of the selected SV ID by the defined value.

This is a global power offset parameter for a satellite. It affects the power level of all signal components of a given satellite.

See ["About satellite's \(SV\) power calculation"](#) on page 82. Power changes are applied on-the-fly.

Remote command:

[:SOURce<hw>] :BB:GNSS:SVID<ch>:GPS:POWer:OFFSet on page 460
(etc. for the other GNSS systems)

Add Power Path-Loss

Requires "Test Mode" > "Navigation".

Adds a power path loss to account for the free-space attenuation and simulate real-world conditions.

The power of the SV ID signals is reduced automatically. The power path-loss is calculated depending on the current satellite's orbit and the distance (range) between the satellite and the receiver's position, see ["Free space path-loss power"](#) on page 82.

To observe the effect, select the "Simulation Monitor" > "Display" > "Power View", see [Chapter 3.3, "Simulation monitor"](#), on page 36.

Remote command:

`[:SOURCE<hw>] :BB:GNSS:SVID<ch>:GPS:POWER:PLoSS` on page 460
(etc. for the other GNSS systems)

Frequency Number

For GLONASS satellites, indicates the frequency number of the subcarrier used to modulate the GLONASS satellite.

If "Nav Msg Type = NAV", the frequency number is retrieved from the imported configuration file.

The value is configurable, if arbitrary data is used, e.g. "Nav Msg Control > Edit" and "Nav Msg Type > All 0".

Remote command:

`[:SOURCE<hw>] :BB:GNSS:SVID<ch>:GLONASS:FNUMBER` on page 459

SV signal configuration table

Table with one or more rows, one row per enabled signal ("GNSS Configuration" > "Systems & Signals" > [Signals](#)).

Signal Power Offset ← SV signal configuration table

Adds power offset for the selected signal.

If more than one signal or bands are activated, the power relation between the signals and between the frequency bands is set automatically, as specified for the GNSS system. You can change these default values. Signal-specific power offset values are set relative to the satellites power level.

See also ["About satellite's \(SV\) power calculation"](#) on page 82.

Remote command:

`[:SOURCE<hw>] :BB:GNSS:SVID<ch>:GPS:SIGNAL:L1Band:CA:POWER:OFFSET`
on page 462

`[:SOURCE<hw>] :BB:GNSS:SVID<ch>:GPS:SIGNAL:L1Band:P:POWER:OFFSET`
on page 462

(etc. for the other GNSS systems)

Copy Power Settings to,SV-ID

Applies the power settings of the current satellite to the selected or to all SV-IDs of the same GNSS system.

The following settings are considered:

- [Power Offset](#)

- [Add Power Path-Loss](#)
- [Signal Power Offset](#)

Remote command:

[:SOURCE<hw>] :BB:GNSS:SVID<ch>:GPS:POWER:COPY:SVID on page 462

[:SOURCE<hw>] :BB:GNSS:SVID<ch>:GPS:POWER:COPY:EXECUTE on page 463

(etc. for the other GNSS systems)

7.2 Modulation control settings

Access:

1. Select "GNSS" > "GNSS Configuration" > "Signals & Systems".
2. Enable the GNSS system for that you want to control the signal modulation, for example:
 - a) "System" > "GLONASS" > "On"
 - b) "System" > "Galileo" > "On"
3. Select "GNSS" > "GNSS Configuration" > "Satellites".
4. Select "GLONASS" > "SV#" > "SV Config".
5. In the "SV Configuration" dialog, select "Signals Configuration".
6. To generate a signal with list mode data, sent on the GLONASS frequency, select:
 - a) "Primary Code" > "Off"
 - b) "Nav Msg Control" > "Edit"
 - c) "Nav Msg Type" > "Data List"
 - d) Load list mode data, e.g. from the file `Glonass_Data.dm_iqd`:
"Nav Msg Content" > `/var/user/Glonass_Data`
 - e) "Meander Sequence" > "Off"
 - f) "Time Sequence" > "Off"

- To apply the modulation control settings of the current satellite to other SV ID, select for example "SV-ID" = "All" and "Copy Modulation Control To"

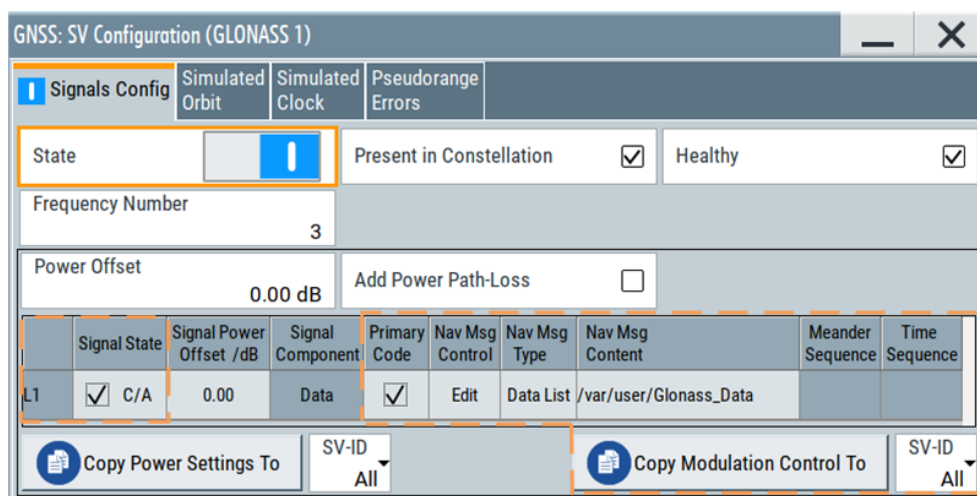

Available modulation control settings depend on the GNSS system and selected RF band.

The remote commands required to define these settings are described in [Chapter 22.12, "Signals and power configuration per satellite"](#), on page 448.

Settings:

- SV signal configuration table.....89
 - L Signal State.....89
 - L Signal Component..... 90
 - L Primary Code..... 90
 - L Secondary Code..... 90
 - L Nav Msg Control..... 90
 - L Nav Msg.....91
 - L Nav Msg Type..... 91
 - L Nav Msg Content..... 92
 - L Meander Sequence..... 92
 - L Time Sequence..... 93
- Copy Modulation Control Settings to,SV-ID..... 93

SV signal configuration table

Table with one or more rows, one row per enabled signal ("GNSS Configuration" > "Systems & Signals" > [Signals](#)).

Signal State ← SV signal configuration table

Activates the selected signal.

The available signals depend on the GNSS system and the configuration in the [Systems&Signals](#) dialog.

At least one signal has to be activated per satellite. Activate another signal to deactivate a particular signal, if it is the only one active at that moment.

Remote command:

`[:SOURCE<hw>] :BB:GNSS:SVID<ch>:GPS:SIGNa1:L1Band:CA [:STATe]`

on page 464

`[:SOURCE<hw>] :BB:GNSS:SVID<ch>:GPS:SIGNa1:L1Band:P [:STATe]`

on page 464

(etc. for the other GNSS systems)

Signal Component ← SV signal configuration table

Indicates the signal content (data only or data and pilot).

The information is retrieved automatically from the selected simulation data source file. Signal components depend on the signal, the frequency band and the GNSS system.

Remote command:

n.a.

Primary Code ← SV signal configuration table

Enables the primary code to spread the data and pilot components.

If your interference tests require the generation of a continuous wave signal send on the same frequency as a specific SV, set "Primary Code" > "Off" and "Nav Msg Control" > "Off".

Remote command:

`[:SOURCE<hw>] :BB:GNSS:SVID<ch>:GPS:SIGNa1:L1Band:CA:DATA:PCODE [:STATe]` on page 467

`[:SOURCE<hw>] :BB:GNSS:SVID<ch>:GPS:SIGNa1:L1Band:CA:PILOT:PCODE [:STATe]` on page 467

(etc. for the other GNSS systems)

Secondary Code ← SV signal configuration table

Enables the secondary code in the pilot and data channel of GPS, Galileo or BeiDou.

Remote command:

`[:SOURCE<hw>] :BB:GNSS:SVID<ch>:GPS:SIGNa1:L1Band:L1C:PILOT:SCODE [:STATe]` on page 468

`[:SOURCE<hw>] :BB:GNSS:SVID<ch>:GPS:SIGNa1:L5Band:L5S:DATA:SCODE [:STATe]` on page 468

`[:SOURCE<hw>] :BB:GNSS:SVID<ch>:GPS:SIGNa1:L5Band:L5S:PILOT:SCODE [:STATe]` on page 468

(etc. for the other GNSS systems)

Nav Msg Control ← SV signal configuration table

Requires "Test Mode" > "Navigation", see "Test Mode" on page 34.

Defines whether the navigation message parameters can be changed or not.

"Auto" Adjusts the navigation message parameters automatically.

"On"/"Edit" Enables configuration of the navigation message parameters ("Nav Msg Type" = "xNav") or configuration of user-defined data ("Nav Msg Type" ≠ "xNav").

For SBAS space vehicles (PRN), the content is predefined.

"Off" Navigation message is disabled.
A pure continuous-wave (CW) signal is output.

Remote command:

[:SOURCE<hw>] :BB:GNSS:SVID<ch>:GPS:SIGNa1:L1Band:CA:DATA:
NMESsage:CONTrol on page 470

[:SOURCE<hw>] :BB:GNSS:SVID<ch>:GPS:SIGNa1:L1Band:P:DATA:
NMESsage:CONTrol on page 470

(etc. for the other GNSS systems)

Nav Msg ← SV signal configuration table

Requires "Test Mode" > "Tracking", see ["Test Mode"](#) on page 34.

Defines whether the navigation message parameters can be changed or not.

"On" Enables configuration of the navigation message parameters ("Nav
Msg Type" = "xNav") or configuration of user-defined data ("Nav Msg
Type" ≠ "xNav").

"Off" Navigation message is disabled.

Remote command:

[:SOURCE<hw>] :BB:GNSS:SVID<ch>:GPS:SIGNa1:L1Band:CA:DATA:
NMESsage [:STATe] on page 590

[:SOURCE<hw>] :BB:GNSS:SVID<ch>:GPS:SIGNa1:L1Band:P:DATA:
NMESsage [:STATe] on page 590

(etc. for the other GNSS systems)

Nav Msg Type ← SV signal configuration table

Sets the data source used for the generation of the navigation message.

"LNAV"/"CNAV"/"FNAV"/"INAV"/"D1NAV"/"D2NAV"/"NAV"

The navigation message parameters are "real" since they are retrieved from the loaded simulation data source file, see [Import Constellation](#).

"D1NAV" denotes navigation messages belonging to BeiDou medium-altitude earth orbit (MEO) satellites (SV ID 6 to SV ID 35).

"D2NAV" denotes navigation messages belonging to BeiDou geostationary (GEO) satellites and inclined geostationary (IGSO) satellites (SV ID 1 to SV ID 5).

Note: Galileo E6 signals carry no real navigation data. The signals are simulated using data sources "PRBSxx"/"Data List"/"Pattern"/"Zero NAV".

To change the automatically filled in values, select:

- [Nav Msg Control > "Edit"](#)
- [Nav Msg Content > Config](#)

"PRBSxx"/"Data List"/"Pattern"

Selects a configurable data source.

The data symbols from the data source are transmitted in the navigation message. The signal is sufficient for simple functional tests and sensitivity tests.

The following standard data sources are available:

- "All 0"/"All 1"
An internally generated sequence containing 0 data or 1 data.
- "PNxx"
An internally generated pseudo-random noise sequence.
- "Pattern"
An internally generated sequence according to a bit pattern. Use the "Pattern" box to set the bit pattern.
- "Data List"/"Select Data List"
Binary data from a list file, internally or externally generated. Select "Select Data List" to open the standard "Select List" dialog. The dialog lists file with file extension *.dm_iqd if existing.
 - Navigate to the list file and tap "Select" to select the file.
 - Use the "New" and "Edit" functions to create a data list internally or to edit an existing one.
 - Use the standard "File Manager" function to transfer external data lists to the instrument.

See also:

- Section "About data signals" in the R&S SMW200A user manual.
- Section "File and data management" in the R&S SMW200A user manual.
- Section "Data list editor" in the R&S SMW200A user manual.

"Zero NAV"

Sets the broadcast orbit and clock correction parameters in the navigation message to zero. Frame structure, timing and channel coding of the navigation message are retained.

Remote command:

`[:SOURce<hw>] :BB:GNSS:SVID<ch>:GPS:SIGNa1:L1Band:CA:DATA:NMESsage:TYPE` on page 472

`[:SOURce<hw>] :BB:GNSS:SVID<ch>:GPS:SIGNa1:L1Band:CA:DATA:NMESsage:DSElect` on page 474

`[:SOURce<hw>] :BB:GNSS:SVID<ch>:GPS:SIGNa1:L1Band:CA:DATA:NMESsage:PATtern` on page 476

(etc. for the other GNSS systems)

Nav Msg Content ← SV signal configuration table

Opens the "Navigation Message" dialog, where you can observe the navigation message parameter and if enabled, change them.

See [Chapter 13, "Perturbations and errors simulation"](#), on page 192.

Meander Sequence ← SV signal configuration table

Enables meandering of GLONASS satellite navigation signals, i.e. doubling the data rate.

Remote command:

[:SOURce<hw>] :BB:GNSS:SVID<ch>:GLONass:SIGNal:L1Band:CA:DATA:MEANdering[:STATe] on page 476

[:SOURce<hw>] :BB:GNSS:SVID<ch>:GLONass:SIGNal:L2Band:CA:DATA:MEANdering[:STATe] on page 476

Time Sequence ← SV signal configuration table

Enables the time signal component of GLONASS satellite navigation signals.

Remote command:

[:SOURce<hw>] :BB:GNSS:SVID<ch>:GLONass:SIGNal:L1Band:CA:DATA:TSEquence[:STATe] on page 477

[:SOURce<hw>] :BB:GNSS:SVID<ch>:GLONass:SIGNal:L2Band:CA:DATA:TSEquence[:STATe] on page 477

Copy Modulation Control Settings to,SV-ID

Applies the power settings of the current satellite to the selected or to all SV-IDs of the same GNSS system.

The following settings are considered:

- [Signal State](#)
- [Primary Code](#)
- [Secondary Code](#)
- [Nav Msg Control](#)
- [Nav Msg Type](#)
- [Meander Sequence](#)
- [Time Sequence](#)

Remote command:

[:SOURce<hw>] :BB:GNSS:SVID<ch>:GPS:MCONtrol:COPY:SVID on page 477

[:SOURce<hw>] :BB:GNSS:SVID<ch>:GPS:MCONtrol:COPY:EXECute on page 478

(etc. for the other GNSS systems)

7.3 Simulated orbit and orbit perturbation settings

Access:

1. Select "GNSS" > "GNSS Configuration" > "Satellites".
2. Select the GNSS system for that you want to configure satellites constellation, for example GPS.
3. Select "SV#" > "SV Config".
4. In the "SV Configuration" dialog, select one of the following:
 - "Simulated Orbit" > "Orbit"
 - "Simulated Orbit" > "Orbit Perturbation"

Available navigation message parameters depend on the GNSS system.

GNSS: SV Configuration (GPS 1)			
Signals Config	Simulated Orbit	Simulated Clock	Pseudorange Errors
Ground Track Plot ...		Orbit	
Reference Week	1 780	Reference Time of Week	288 000 s
Sqrt. of Semi-major Axis - $A^{1/2}$	5 153.628 906 m ^{1/2}	Eccentricity - e	0.002 737 999
Inclination Angle - i_0	0.305 935 668 8 semic.	Longitude of Ascending Node - Ω_0	0.018 540 220 3 semic
Argument of Perigee - ω	0.117 445 588 1 semic.	Mean Anomaly - M_0	0.555 010 156 7 semic.
Rate of Inclination Angle - i'	0.000 000 000 000 0 semic./s	Rate of Right Ascension - Ω'	-0.000 000 002 524 8 semic./s
Mean Motion Difference - Δ_n	0.000 000 000 000 0 semic./s		

Settings:

- Ground Track..... 94
- GPS SV..... 94
 - Simulated Orbit..... 95
 - Orbit Perturbation..... 95
- Galileo SV..... 96
 - Simulated Orbit..... 96
 - Orbit Perturbation..... 96
- GLONASS SV..... 97
 - Simulated Orbit..... 97
- BeiDou SV..... 98
 - Simulated Orbit..... 98
 - Orbit Perturbation..... 98
- NavIC SV..... 99
 - Simulated Orbit..... 99
 - Orbit Perturbation..... 100
- QZSS SV..... 100
 - Simulated Orbit..... 100
 - Orbit Perturbation..... 101
 - NavIC SV..... 101
 - Simulated Orbit..... 101
 - Orbit Perturbation..... 102

Ground Track

Displays a plot of the trajectory of the selected satellite.

To observe the aggregated ground tracks of all satellites, select "GNSS > Simulation Monitor > Display = Satellites > Ground Track".

GPS SV

Comprises the navigation message parameters, specific to and common for all GPS satellites.

Simulated orbit and orbit perturbation settings

Simulated Orbit ← GPS SV

Comprises the navigation message parameters, specific to and common for all GPS satellites.

Parameter	Remote command:
"Reference Week"	[:SOURCE<hw>] :BB:GNSS:SVID<ch>:GPS:SIMulated:ORBit:WNOE on page 484
"Reference Time of Week"	[:SOURCE<hw>] :BB:GNSS:SVID<ch>:GPS:SIMulated:ORBit:TOE on page 484
"Square Root of Semi-Major Axis - $A^{1/2}$ "	[:SOURCE<hw>] :BB:GNSS:SVID<ch>:GPS:SIMulated:ORBit:SQRA on page 486
"Eccentricity - e"	[:SOURCE<hw>] :BB:GNSS:SVID<ch>:GPS:SIMulated:ORBit:ECCentricity on page 486
"Inclination Angle - i_0 "	[:SOURCE<hw>] :BB:GNSS:SVID<ch>:GPS:SIMulated:ORBit:IZERo on page 486
"Longitude of Ascending Node - Ω_0 "	[:SOURCE<hw>] :BB:GNSS:SVID<ch>:GPS:SIMulated:ORBit:OZERo on page 487
"Argument of Perigee - ω "	[:SOURCE<hw>] :BB:GNSS:SVID<ch>:GPS:SIMulated:ORBit:OMEGa on page 487
"Mean Anomaly - M_0 "	[:SOURCE<hw>] :BB:GNSS:SVID<ch>:GPS:SIMulated:ORBit:MZERo on page 487
"Rate of Inclination Angle - i'' "	[:SOURCE<hw>] :BB:GNSS:SVID<ch>:GPS:SIMulated:ORBit:IDOT on page 487
"Rate of Right Ascension - Ω'' "	[:SOURCE<hw>] :BB:GNSS:SVID<ch>:GPS:SIMulated:ORBit:ODOT on page 488
"Mean Motion Difference - Δ_n "	[:SOURCE<hw>] :BB:GNSS:SVID<ch>:GPS:SIMulated:ORBit:NDELta on page 488

Orbit Perturbation ← GPS SV

Comprises the navigation message parameters, specific to and common for all GPS satellites.

Parameter	Remote command:
"Cosine Difference of Latitude - C_{uc} "	[:SOURCE<hw>] :BB:GNSS:SVID<ch>:GPS:SIMulated:ORBit:CUC on page 488
"Sine Difference of Latitude - C_{us} "	[:SOURCE<hw>] :BB:GNSS:SVID<ch>:GPS:SIMulated:ORBit:CUS on page 488
"Cosine Difference of Orbital Radius - C_{rc} "	[:SOURCE<hw>] :BB:GNSS:SVID<ch>:GPS:SIMulated:ORBit:CRc on page 489
"Sine Difference of Orbital Radius - C_{rs} "	[:SOURCE<hw>] :BB:GNSS:SVID<ch>:GPS:SIMulated:ORBit:CRs on page 489

Simulated orbit and orbit perturbation settings

Parameter	Remote command:
"Cosine Difference of Inclination - C_{ic} "	<code>[:SOURCE<hw>] :BB:GNSS:SVID<ch>:GPS:SIMulated:ORBit:CIC</code> on page 489
"Sine Difference of Inclination - C_{is} "	<code>[:SOURCE<hw>] :BB:GNSS:SVID<ch>:GPS:SIMulated:ORBit:CIS</code> on page 490

Galileo SV

Comprises the navigation message parameters, specific to and common for all Galileo satellites.

Simulated Orbit ← Galileo SV

Comprises the navigation message parameters, specific to and common for all Galileo satellites.

Parameter	Remote command:
"Reference Week"	<code>[:SOURCE<hw>] :BB:GNSS:SVID<ch>:GALileo:SIMulated:ORBit:WNOE</code> on page 484
"Reference Time of Week"	<code>[:SOURCE<hw>] :BB:GNSS:SVID<ch>:GALileo:SIMulated:ORBit:TOE</code> on page 484
"Square Root of Semi-Major Axis - $A^{1/2}$ "	<code>[:SOURCE<hw>] :BB:GNSS:SVID<ch>:GALileo:SIMulated:ORBit:SQRA</code> on page 486
"Eccentricity - e "	<code>[:SOURCE<hw>] :BB:GNSS:SVID<ch>:GALileo:SIMulated:ORBit:ECCentricity</code> on page 486
"Inclination Angle - i_0 "	<code>[:SOURCE<hw>] :BB:GNSS:SVID<ch>:GALileo:SIMulated:ORBit:IZERo</code> on page 486
"Longitude of Ascending Node - Ω_0 "	<code>[:SOURCE<hw>] :BB:GNSS:SVID<ch>:GALileo:SIMulated:ORBit:OZERo</code> on page 486
"Argument of Perigee - ω "	<code>[:SOURCE<hw>] :BB:GNSS:SVID<ch>:GALileo:SIMulated:ORBit:OMEGa</code> on page 487
"Mean Anomaly - M_0 "	<code>[:SOURCE<hw>] :BB:GNSS:SVID<ch>:GALileo:SIMulated:ORBit:MZERo</code> on page 487
"Rate of Inclination Angle - i'' "	<code>[:SOURCE<hw>] :BB:GNSS:SVID<ch>:GALileo:SIMulated:ORBit:IDOT</code> on page 487
"Rate of Right Ascension - Ω'' "	<code>[:SOURCE<hw>] :BB:GNSS:SVID<ch>:GALileo:SIMulated:ORBit:ODOT</code> on page 488
"Mean Motion Difference - Δ_n "	<code>[:SOURCE<hw>] :BB:GNSS:SVID<ch>:GALileo:SIMulated:ORBit:NDELta</code> on page 488

Orbit Perturbation ← Galileo SV

Comprises the navigation message parameters, specific to and common for all Galileo satellites.

Simulated orbit and orbit perturbation settings

Parameter	Remote command:
"Cosine Difference of Latitude - C_{uc} "	[:SOURCE<hw>] :BB:GNSS:SVID<ch>:GALileo: SIMulated:ORBit:CUC on page 488
"Sine Difference of Latitude - C_{us} "	[:SOURCE<hw>] :BB:GNSS:SVID<ch>:GALileo: SIMulated:ORBit:CUS on page 488
"Cosine Difference of Orbital Radius - C_{rc} "	[:SOURCE<hw>] :BB:GNSS:SVID<ch>:GALileo: SIMulated:ORBit:CRc on page 489
"Sine Difference of Orbital Radius - C_{rs} "	[:SOURCE<hw>] :BB:GNSS:SVID<ch>:GALileo: SIMulated:ORBit:CRS on page 489
"Cosine Difference of Inclination - C_{ic} "	[:SOURCE<hw>] :BB:GNSS:SVID<ch>:GALileo: SIMulated:ORBit:CIC on page 489
"Sine Difference of Inclination - C_{is} "	[:SOURCE<hw>] :BB:GNSS:SVID<ch>:GALileo: SIMulated:ORBit:CIS on page 489

GLONASS SV

Comprises the navigation message parameters, specific to and common for all GLONASS satellites.

Simulated Orbit ← GLONASS SV

Comprises the navigation message parameters, specific to and common for all GLONASS satellites.

Parameter	Remote command:
"Reference Date"	[:SOURCE<hw>] :BB:GNSS:SVID<ch>:GLONass: SIMulated:ORBit:DATE on page 485
"Reference Time"	[:SOURCE<hw>] :BB:GNSS:SVID<ch>:GLONass: SIMulated:ORBit:TIME on page 485
" X_n "	[:SOURCE<hw>] :BB:GNSS:SVID<ch>:GLONass: SIMulated:ORBit:XN on page 483
" Y_n "	[:SOURCE<hw>] :BB:GNSS:SVID<ch>:GLONass: SIMulated:ORBit:YN on page 483
" Z_n "	[:SOURCE<hw>] :BB:GNSS:SVID<ch>:GLONass: SIMulated:ORBit:ZN on page 483
" X'_n "	[:SOURCE<hw>] :BB:GNSS:SVID<ch>:GLONass: SIMulated:ORBit:XDN on page 483
" Y'_n "	[:SOURCE<hw>] :BB:GNSS:SVID<ch>:GLONass: SIMulated:ORBit:YDN on page 484
" Z'_n "	[:SOURCE<hw>] :BB:GNSS:SVID<ch>:GLONass: SIMulated:ORBit:ZDN on page 484
" X''_n "	[:SOURCE<hw>] :BB:GNSS:SVID<ch>:GLONass: SIMulated:ORBit:XDDN on page 484

Simulated orbit and orbit perturbation settings

Parameter	Remote command:
"Y" _n	[:SOURCE<hw>] :BB:GNSS:SVID<ch>:GLONASS:SIMulated:ORBit:YDDN on page 484
"Z" _n	[:SOURCE<hw>] :BB:GNSS:SVID<ch>:GLONASS:SIMulated:ORBit:ZDDN on page 484

BeiDou SV

Comprises the navigation message parameters, specific to and common for all BeiDou satellites.

Simulated Orbit ← BeiDou SV

Comprises the navigation message parameters, specific to and common for all BeiDou satellites.

Parameter	Remote command:
"Reference Week"	[:SOURCE<hw>] :BB:GNSS:SVID<ch>:BEIDou:SIMulated:ORBit:WNOE on page 484
"Reference Time of Week"	[:SOURCE<hw>] :BB:GNSS:SVID<ch>:BEIDou:SIMulated:ORBit:TOE on page 484
"Square Root of Semi-Major Axis - A ^{1/2} "	[:SOURCE<hw>] :BB:GNSS:SVID<ch>:BEIDou:SIMulated:ORBit:SQRA on page 486
"Eccentricity - e"	[:SOURCE<hw>] :BB:GNSS:SVID<ch>:BEIDou:SIMulated:ORBit:ECCentricity on page 486
"Inclination Angle - i ₀ "	[:SOURCE<hw>] :BB:GNSS:SVID<ch>:BEIDou:SIMulated:ORBit:IZERo on page 486
"Longitude of Ascending Node - Ω ₀ "	[:SOURCE<hw>] :BB:GNSS:SVID<ch>:BEIDou:SIMulated:ORBit:OZERo on page 487
"Argument of Perigee - ω"	[:SOURCE<hw>] :BB:GNSS:SVID<ch>:BEIDou:SIMulated:ORBit:OMEGa on page 487
"Mean Anomaly - M ₀ "	[:SOURCE<hw>] :BB:GNSS:SVID<ch>:BEIDou:SIMulated:ORBit:MZERo on page 487
"Rate of Inclination Angle - i"	[:SOURCE<hw>] :BB:GNSS:SVID<ch>:BEIDou:SIMulated:ORBit:IDOT on page 487
"Rate of Right Ascension - Ω"	[:SOURCE<hw>] :BB:GNSS:SVID<ch>:BEIDou:SIMulated:ORBit:ODOT on page 488
"Mean Motion Difference - Δ _n "	[:SOURCE<hw>] :BB:GNSS:SVID<ch>:BEIDou:SIMulated:ORBit:NDELta on page 488

Orbit Perturbation ← BeiDou SV

Comprises the navigation message parameters, specific to and common for all BeiDou satellites.

Simulated orbit and orbit perturbation settings

Parameter	Remote command:
"Cosine Difference of Latitude - C_{uc} "	[:SOURCE<hw>] :BB:GNSS:SVID<ch>:BEIDou:SIMulated:ORBit:CUC on page 488
"Sine Difference of Latitude - C_{us} "	[:SOURCE<hw>] :BB:GNSS:SVID<ch>:BEIDou:SIMulated:ORBit:CUS on page 488
"Cosine Difference of Orbital Radius - C_{rc} "	[:SOURCE<hw>] :BB:GNSS:SVID<ch>:BEIDou:SIMulated:ORBit:CRc on page 489
"Sine Difference of Orbital Radius - C_{rs} "	[:SOURCE<hw>] :BB:GNSS:SVID<ch>:BEIDou:SIMulated:ORBit:CRS on page 489
"Cosine Difference of Inclination - C_{ic} "	[:SOURCE<hw>] :BB:GNSS:SVID<ch>:BEIDou:SIMulated:ORBit:CIC on page 489
"Sine Difference of Inclination - C_{is} "	[:SOURCE<hw>] :BB:GNSS:SVID<ch>:BEIDou:SIMulated:ORBit:CIS on page 490

NavIC SV

Comprises the navigation message parameters, specific to and common for all NavIC satellites.

Simulated Orbit ← NavIC SV

Comprises the navigation message parameters, specific to and common for all BeiDou satellites.

Parameter	Remote command:
"Reference Week"	[:SOURCE<hw>] :BB:GNSS:SVID<ch>:BEIDou:SIMulated:ORBit:WNOE on page 484
"Reference Time of Week"	[:SOURCE<hw>] :BB:GNSS:SVID<ch>:BEIDou:SIMulated:ORBit:TOE on page 484
"Square Root of Semi-Major Axis - $A^{1/2}$ "	[:SOURCE<hw>] :BB:GNSS:SVID<ch>:BEIDou:SIMulated:ORBit:SQRA on page 486
"Eccentricity - e "	[:SOURCE<hw>] :BB:GNSS:SVID<ch>:BEIDou:SIMulated:ORBit:ECCentricity on page 486
"Inclination Angle - i_0 "	[:SOURCE<hw>] :BB:GNSS:SVID<ch>:BEIDou:SIMulated:ORBit:IZERO on page 486
"Longitude of Ascending Node - Ω_0 "	[:SOURCE<hw>] :BB:GNSS:SVID<ch>:BEIDou:SIMulated:ORBit:OZERO on page 487
"Argument of Perigee - ω "	[:SOURCE<hw>] :BB:GNSS:SVID<ch>:BEIDou:SIMulated:ORBit:OMEGA on page 487
"Mean Anomaly - M_0 "	[:SOURCE<hw>] :BB:GNSS:SVID<ch>:BEIDou:SIMulated:ORBit:MZERO on page 487
"Rate of Inclination Angle - i'' "	[:SOURCE<hw>] :BB:GNSS:SVID<ch>:BEIDou:SIMulated:ORBit:IDOT on page 487

Simulated orbit and orbit perturbation settings

Parameter	Remote command:
"Rate of Right Ascension - Ω "	[:SOURCE<hw>] :BB:GNSS:SVID<ch>:BEIDou:SIMulated:ORBit:ODOT on page 488
"Mean Motion Difference - Δ_n "	[:SOURCE<hw>] :BB:GNSS:SVID<ch>:BEIDou:SIMulated:ORBit:NDELta on page 488

Orbit Perturbation ← NAVIC SV

Comprises the navigation message parameters, specific to and common for all BeiDou satellites.

Parameter	Remote command:
"Cosine Difference of Latitude - C_{uc} "	[:SOURCE<hw>] :BB:GNSS:SVID<ch>:BEIDou:SIMulated:ORBit:CUC on page 488
"Sine Difference of Latitude - C_{us} "	[:SOURCE<hw>] :BB:GNSS:SVID<ch>:BEIDou:SIMulated:ORBit:CUS on page 488
"Cosine Difference of Orbital Radius - C_{rc} "	[:SOURCE<hw>] :BB:GNSS:SVID<ch>:BEIDou:SIMulated:ORBit:CRc on page 489
"Sine Difference of Orbital Radius - C_{rs} "	[:SOURCE<hw>] :BB:GNSS:SVID<ch>:BEIDou:SIMulated:ORBit:CRS on page 489
"Cosine Difference of Inclination - C_{ic} "	[:SOURCE<hw>] :BB:GNSS:SVID<ch>:BEIDou:SIMulated:ORBit:CIC on page 489
"Sine Difference of Inclination - C_{is} "	[:SOURCE<hw>] :BB:GNSS:SVID<ch>:BEIDou:SIMulated:ORBit:CIS on page 490

QZSS SV

Comprises the navigation message parameters, specific to and common for all QZSS satellites.

Simulated Orbit ← QZSS SV

Comprises the navigation message parameters, specific to and common for all QZSS satellites.

Parameter	Remote command:
"Reference Week"	[:SOURCE<hw>] :BB:GNSS:SVID<ch>:QZSS:SIMulated:ORBit:WNOE on page 484
"Reference Time of Week"	[:SOURCE<hw>] :BB:GNSS:SVID<ch>:QZSS:SIMulated:ORBit:TOE on page 484
"Square Root of Semi-Major Axis - $A^{1/2}$ "	[:SOURCE<hw>] :BB:GNSS:SVID<ch>:QZSS:SIMulated:ORBit:SQRA on page 485
"Eccentricity - e "	[:SOURCE<hw>] :BB:GNSS:SVID<ch>:QZSS:SIMulated:ORBit:ECCentricity on page 486
"Inclination Angle - i_0 "	[:SOURCE<hw>] :BB:GNSS:SVID<ch>:QZSS:SIMulated:ORBit:IZERO on page 486
"Longitude of Ascending Node - Ω_0 "	[:SOURCE<hw>] :BB:GNSS:SVID<ch>:QZSS:SIMulated:ORBit:OZERO on page 486

Simulated orbit and orbit perturbation settings

Parameter	Remote command:
"Argument of Perigee - ω "	[:SOURCE<hw>] :BB:GNSS:SVID<ch>:QZSS:SIMulated:ORBit:OMEGA on page 487
"Mean Anomaly - M_0 "	[:SOURCE<hw>] :BB:GNSS:SVID<ch>:QZSS:SIMulated:ORBit:MZERO on page 487
"Rate of Inclination Angle - i "	[:SOURCE<hw>] :BB:GNSS:SVID<ch>:QZSS:SIMulated:ORBit:IDOT on page 487
"Rate of Right Ascension - Ω "	[:SOURCE<hw>] :BB:GNSS:SVID<ch>:QZSS:SIMulated:ORBit:ODOT on page 488
"Mean Motion Difference - Δ_n "	[:SOURCE<hw>] :BB:GNSS:SVID<ch>:QZSS:SIMulated:ORBit:NDELta on page 488

Orbit Perturbation ← QZSS SV

Comprises the navigation message parameters, specific to and common for all QZSS satellites.

Parameter	Remote command:
"Cosine Difference of Latitude - C_{uc} "	[:SOURCE<hw>] :BB:GNSS:SVID<ch>:QZSS:SIMulated:ORBit:CUC on page 488
"Sine Difference of Latitude - C_{us} "	[:SOURCE<hw>] :BB:GNSS:SVID<ch>:QZSS:SIMulated:ORBit:CUS on page 488
"Cosine Difference of Orbital Radius - C_{rc} "	[:SOURCE<hw>] :BB:GNSS:SVID<ch>:QZSS:SIMulated:ORBit:CRC on page 489
"Sine Difference of Orbital Radius - C_{rs} "	[:SOURCE<hw>] :BB:GNSS:SVID<ch>:QZSS:SIMulated:ORBit:CRS on page 489
"Cosine Difference of Inclination - C_{ic} "	[:SOURCE<hw>] :BB:GNSS:SVID<ch>:QZSS:SIMulated:ORBit:CIC on page 489
"Sine Difference of Inclination - C_{is} "	[:SOURCE<hw>] :BB:GNSS:SVID<ch>:QZSS:SIMulated:ORBit:CIS on page 489

NavIC SV ← QZSS SV

Comprises the navigation message parameters, specific to and common for all NavIC satellites.

Simulated Orbit ← NavIC SV ← QZSS SV

Comprises the navigation message parameters, specific to and common for all NavIC satellites.

Parameter	Remote command:
"Reference Week"	[:SOURCE<hw>] :BB:GNSS:SVID<ch>:NAVic:SIMulated:ORBit:WNOE on page 484
"Reference Time of Week"	[:SOURCE<hw>] :BB:GNSS:SVID<ch>:NAVic:SIMulated:ORBit:TOE on page 484
"Square Root of Semi-Major Axis - $A^{1/2}$ "	[:SOURCE<hw>] :BB:GNSS:SVID<ch>:NAVic:SIMulated:ORBit:SQRA on page 485

Parameter	Remote command:
"Eccentricity - e"	[:SOURCE<hw>] :BB:GNSS:SVID<ch>:NAVIC:SIMulated:ORBit:ECCentricity on page 486
"Inclination Angle - i_0 "	[:SOURCE<hw>] :BB:GNSS:SVID<ch>:NAVIC:SIMulated:ORBit:IZERo on page 486
"Longitude of Ascending Node - Ω_0 "	[:SOURCE<hw>] :BB:GNSS:SVID<ch>:NAVIC:SIMulated:ORBit:OZERo on page 486
"Argument of Perigee - ω "	[:SOURCE<hw>] :BB:GNSS:SVID<ch>:NAVIC:SIMulated:ORBit:OMEGa on page 487
"Mean Anomaly - M_0 "	[:SOURCE<hw>] :BB:GNSS:SVID<ch>:NAVIC:SIMulated:ORBit:MZERo on page 487
"Rate of Inclination Angle - i'' "	[:SOURCE<hw>] :BB:GNSS:SVID<ch>:NAVIC:SIMulated:ORBit:IDOT on page 487
"Rate of Right Ascension - Ω'' "	[:SOURCE<hw>] :BB:GNSS:SVID<ch>:NAVIC:SIMulated:ORBit:ODOT on page 488
"Mean Motion Difference - Δ_n "	[:SOURCE<hw>] :BB:GNSS:SVID<ch>:NAVIC:SIMulated:ORBit:NDELta on page 488

Orbit Perturbation ← NavIC SV ← QZSS SV

Comprises the navigation message parameters, specific to and common for all NavIC satellites.

Parameter	Remote command:
"Cosine Difference of Latitude - C_{uc} "	[:SOURCE<hw>] :BB:GNSS:SVID<ch>:NAVIC:SIMulated:ORBit:CUC on page 488
"Sine Difference of Latitude - C_{us} "	[:SOURCE<hw>] :BB:GNSS:SVID<ch>:NAVIC:SIMulated:ORBit:CUS on page 488
"Cosine Difference of Orbital Radius - C_{rc} "	[:SOURCE<hw>] :BB:GNSS:SVID<ch>:NAVIC:SIMulated:ORBit:CRC on page 489
"Sine Difference of Orbital Radius - C_{rs} "	[:SOURCE<hw>] :BB:GNSS:SVID<ch>:NAVIC:SIMulated:ORBit:CRS on page 489
"Cosine Difference of Inclination - C_{ic} "	[:SOURCE<hw>] :BB:GNSS:SVID<ch>:NAVIC:SIMulated:ORBit:CIC on page 489
"Sine Difference of Inclination - C_{is} "	[:SOURCE<hw>] :BB:GNSS:SVID<ch>:NAVIC:SIMulated:ORBit:CIS on page 489

7.4 Simulated clock settings

Access:

1. Select "GNSS" > "GNSS Configuration" > "Satellites".

2. Select the GNSS system for that you want to configure satellites constellation, for example GPS.
3. Select "SV#" > "SV Config".
4. In the "SV Configuration" dialog, select "Simulated Clock".

Available navigation message parameters depend on the GNSS system.

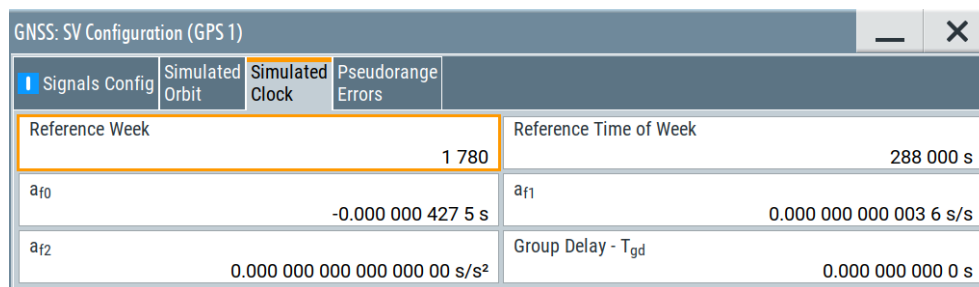

Settings:

GPS > Simulated Clock.....103

Galileo > Simulated Clock.....103

GLONASS > Simulated Clock.....104

BeiDou > Simulated Clock.....104

QZSS > Simulated Clock.....104

NavIC > Simulated Clock.....105

GPS > Simulated Clock

Comprises the navigation message parameters, specific to and common for all GPS satellites.

Parameter	Remote command:
"Reference Week"	[:SOURCE<hw>] :BB:GNSS:SVID<ch>:GPS:SIMulated:CLOCK:WNOc on page 490
"Reference Time of Week"	[:SOURCE<hw>] :BB:GNSS:SVID<ch>:GPS:SIMulated:CLOCK:TOC on page 490
"a _{f0} - a _{f2} "	[:SOURCE<hw>] :BB:GNSS:SVID<ch>:GPS:SIMulated:CLOCK:AF<s2us0> on page 490
"Group Delay - T _{gd} "	[:SOURCE<hw>] :BB:GNSS:SVID<ch>:GPS:SIMulated:CLOCK:TGD on page 491

Galileo > Simulated Clock

Comprises the navigation message parameters, specific to and common for all Galileo satellites.

Parameter	Remote command:
"Reference Week"	[:SOURCE<hw>] :BB:GNSS:SVID<ch>:GALileo: SIMulated:CLOCK:WNOc on page 490
"Time of Clock - t_{oc} (E1-E5B)"	[:SOURCE<hw>] :BB:GNSS:SVID<ch>:GALileo: SIMulated:CLOCK:TOC on page 490
" a_{f0} (E1-E5B)" to " a_{f2} (E1-E5B)"	[:SOURCE<hw>] :BB:GNSS:SVID<ch>:GALileo: SIMulated:CLOCK:AF<s2us0> on page 490
"Group Delay - BGD (E1-E5B)"	[:SOURCE<hw>] :BB:GNSS:SVID<ch>:GALileo: SIMulated:CLOCK:TGD on page 491

GLONASS > Simulated Clock

Comprises the navigation message parameters, specific to and common for all GLONASS satellites.

Parameter	Remote command:
"Reference Date"	[:SOURCE<hw>] :BB:GNSS:SVID<ch>:GLONass: SIMulated:CLOCK:DATE on page 485
"Reference Time"	[:SOURCE<hw>] :BB:GNSS:SVID<ch>:GLONass: SIMulated:CLOCK:TIME on page 485
" a_{f0} " to " a_{f2} "	[:SOURCE<hw>] :BB:GNSS:SVID<ch>:GLONass: SIMulated:CLOCK:AF<s2us0> on page 490
"Group Delay - T_{gd} "	[:SOURCE<hw>] :BB:GNSS:SVID<ch>:GLONass: SIMulated:CLOCK:TGD on page 491

BeiDou > Simulated Clock

Comprises the navigation message parameters, specific to and common for all BeiDou satellites.

Parameter	Remote command:
"Reference Week"	[:SOURCE<hw>] :BB:GNSS:SVID<ch>:BEIDou: SIMulated:CLOCK:WNOc on page 490
"Reference Time of Week"	[:SOURCE<hw>] :BB:GNSS:SVID<ch>:BEIDou: SIMulated:CLOCK:TOC on page 490
" a_{f0} " to " a_{f2} "	[:SOURCE<hw>] :BB:GNSS:SVID<ch>:BEIDou: SIMulated:CLOCK:AF<s2us0> on page 490
"Group Delay B1I - T_{GD1} " "Group Delay B2I - T_{GD2} "	[:SOURCE<hw>] :BB:GNSS:SVID<ch>:BEIDou: PRERrors:MODE on page 493

QZSS > Simulated Clock

Comprises the navigation message parameters, specific to and common for all QZSS satellites.

Parameter	Remote command:
"Reference Week"	[:SOURCE<hw>] :BB:GNSS:SVID<ch>:QZSS:SIMulated:CLOCK:WNOC on page 490
"Reference Time of Week"	[:SOURCE<hw>] :BB:GNSS:SVID<ch>:QZSS:SIMulated:CLOCK:TOC on page 490
" $a_{f0} - a_{f2}$ "	[:SOURCE<hw>] :BB:GNSS:SVID<ch>:QZSS:SIMulated:CLOCK:AF<s2us0> on page 490
"Group Delay - T_{gd} "	[:SOURCE<hw>] :BB:GNSS:SVID<ch>:QZSS:SIMulated:CLOCK:TGD on page 491

NavIC > Simulated Clock

Comprises the navigation message parameters, specific to and common for all NavIC satellites.

Parameter	Remote command:
"Reference Week"	[:SOURCE<hw>] :BB:GNSS:SVID<ch>:NAVic:SIMulated:CLOCK:WNOC on page 490
"Reference Time of Week"	[:SOURCE<hw>] :BB:GNSS:SVID<ch>:NAVic:SIMulated:CLOCK:TOC on page 490
" $a_{f0} - a_{f2}$ "	[:SOURCE<hw>] :BB:GNSS:SVID<ch>:NAVic:SIMulated:CLOCK:AF<s2us0> on page 490
"Group Delay - T_{gd} "	[:SOURCE<hw>] :BB:GNSS:SVID<ch>:NAVic:SIMulated:CLOCK:TGD on page 491

8 Real-world environment

Ideal environment versus real-world environment

By default, the GNSS firmware application simulates an ideal environment between a GNSS receiver and the satellite constellation. This ideal situation includes the following:

- The GNSS receiver is static.
- The GNSS receiver has a line-of-sight (LOS) connection to the satellites.
- Excluded satellites from the constellation are invisible to the GNSS receiver.

A more realistic approach includes environmental effects on a dynamic GNSS receiver. This chapter covers the impact of environmental effects and receiver dynamics on the receiver positioning (pseudorange calculation) accuracy. The following sections explain the different impact factors.

Advanced receiver dynamics

Simulating the receiver movement requires definition of the receiver trajectory within a file. Additional to the movement, the dynamic characteristics include spinning and attitude behavior of the GNSS receiver.

Static multipath propagation

A received GNSS signal does not only consist of the LOS component. Additional components are signal scatters or signal echoes that result from reflections from objects in the environment of the GNSS receiver. The propagation of the GNSS signal is a multipath propagation. The GNSS firmware application simulates static multipath effects, also in addition to effects resulting from an obscured environment.

Obscurations and multipath effects

In obscured environments, the received GNSS signal originates from fewer satellites than the satellite constellation displays. The number of visible satellites is typically higher at the same position without obscurations like surrounding buildings. In rural or suburban areas, in tunnels or in car parking places, some satellites are partly or completely obscured. A wall or a vertical plane obscures the receiver although the receiver is theoretically visible for that particular location. From other satellites, the receiver receives only the echoes, because there is no LOS connection to the satellites. Receivers experience also effects of signal reflection caused by a water surfaces or the ground.

Throughout this user manual, the combinations of environmental effects denote obscuration and multipath.

Antenna patterns and body masks

GNSS receivers in vehicles typically have several built-in antennas to improve the reliability of the received signal. The receivers experience additional obscurations that arise from the vehicle body and the movement. To simulate the effects on the antenna, you can load antenna patterns and body mask files.

Required options

For simulation of atmospheric effects, a GNSS system option is sufficient. Simulation of GNSS receiver spinning, attitude changes and environmental effects require R&S SMW-K108. Simulation of obscured environments also requires a wideband instrument (R&S SMW-B9).

See also [Chapter 2.1, "Required options"](#), on page 17.

For information on perturbation, pseudorange errors and clock errors, or the impact of the atmosphere on pseudorange calculation accuracy, see [Chapter 13, "Perturbations and errors simulation"](#), on page 192.

• Spinning and attitude simulation	107
• Antenna pattern and body mask	108
• Supported environment models	110
• Supported multipath models	113
• Simulating real-world effects	114
• Antenna and body mask settings	125
• Environment configuration settings	132

8.1 Spinning and attitude simulation

In a real-world scenario, a receiver placed in an airplane does not always receive the signal of all theoretically visible satellites at its current position. Depending on the orientation of the vehicle, several satellites can be partly or completely obscured. The orientation of the vehicle is described with the three flight dynamics parameters, the yaw (heading), pitch (elevation) and roll (bank), see [Figure 8-1](#).

Equipped with option R&S SMW-K108, the R&S SMW200A allows you to configure a vehicle attitude or the body rotation parameters yaw, pitch, and roll. The instrument calculates the power and the carrier phase response of a specific satellite or a multipath reflection at a specific angle of arrival (AoA).

The calculation is based on the defined attitude profile and the selected antenna pattern. The power values and carrier phase offsets of all satellite signals are updated in real time and with an update rate of 100 Hz.

With enabled spinning, the software additionally simulates a constant rate of change of the roll.

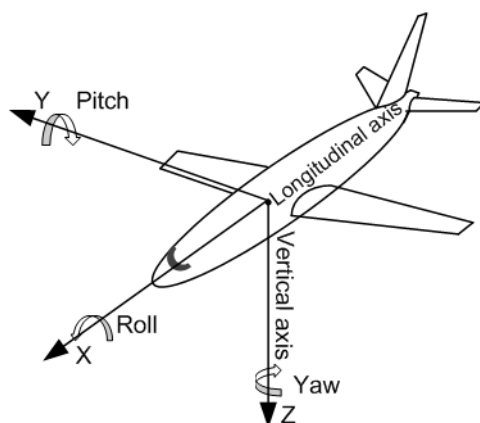

Figure 8-1: Flight dynamics parameters: yaw (heading), pitch (elevation) and roll (bank)

For related settings, see [Chapter 5.3.3, "Motion and attitude configuration and settings"](#), on page 64.

8.2 Antenna pattern and body mask

In the practice, a moving receiver is actually a GNSS receiver mounted in a car, airplane or other vehicle. A GNSS receiver often comprises of more than one antenna or uses directional antennas rather than isotropic one for improving the reception.

To account for these effects, the R&S SMW200A enables you to apply antenna patterns, body masks and to simulate real-life scenarios, like a GNSS antenna placed in a car. The instrument provides an interface for loading and creating user-defined antenna patterns and body masks. The antenna patterns and body masks are files with predefined file extension (`*.ant_pat/*.body_mask`) and file format as described in [Chapter A.3, "Antenna pattern and body mask files"](#), on page 663.

You can define up to four antennas per vehicle.

Antenna pattern and body mask model

You find a subset of predefined body masks files of some generic vehicular models. The models are simplified general models based on the following assumptions:

- All surfaces of the vehicle body are considered as planes
- Ground reflection is not considered for land vehicles; described is only the top body of a car, the part from the window to the roof
- The receiver is placed at the central vertical plane.

A body mask is basically a table with rows of elevation angles in the range $+90^\circ$ to -90° and columns of azimuth from -180° to $+180^\circ$. Each table element gives the signal power attenuation in dB of the incident signal. The predefined body masks have up to three regions: pass, attenuated pass and non-pass. The resolution of the power response and carrier phase offsets is up to 1° for both, the elevation and azimuth.

The resulting body mask of a medium-sized car with roof-top as illustrated on Figure 8-2 is given on Figure 8-3.

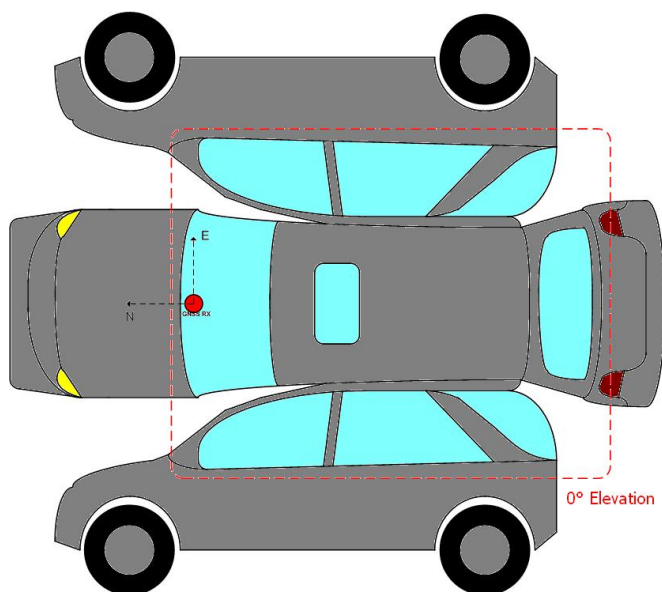

Figure 8-2: Illustration of a medium-sized car with roof-top

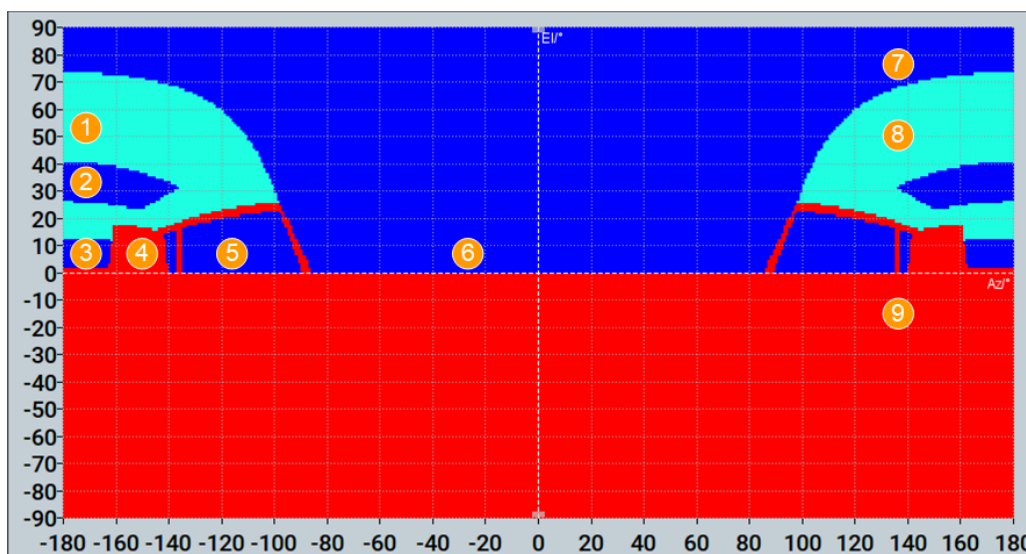

Figure 8-3: Body mask of the medium-sized car with roof-tops (Azimuth -180° to +180°)

- 1 = Roof
- 2 = Roof window
- 3 = Back window
- 4 = Seat
- 5 = Side window
- 6 = Front window

- 7 = Pass region (dark blue color): the incident signal is not attenuated and the table elements are set to 0 dB
- 8 = Attenuated pass region (light blue color): the incident signal is attenuated but not fully blocked; the table elements are set to 15 dB.
- 9 = Non-pass region (red color): the incident signal is heavily blocked and the table elements are set to 40 dB

Possible application fields

- Automotive applications
Attitude parameters are automatically extracted from the user-defined motion vector.
- Body mask applications
Three files describe an antenna: the antenna pattern `*.ant_pat` (or power response) file, the phase response `*.phase` file and the body mask file `*.body_mask`.
Antenna pattern and phase response files must have the same filename and must be saved in the same directory.
If the required `*.phase` file does not exist, the carrier phase matrix is assumed to be zero.
- Outdoor scenarios
Antenna patterns are applied on reflections from the defined environment model, e.g multi-path.
- Indoor absorption scenarios
Antenna patterns can also be used to simulate the signal absorption and the carrier phase bias from any angle around a GNSS receiver.
- Over-the-air (OTA) test
You can also load antenna patterns measured by some over-the-air (OTA) measurements, e.g the R&S®DST200 RF Diagnostic Chamber.

8.3 Supported environment models

R&S SMW200A equipped with R&S SMW-K108 enables you to apply different environment models and automatically simulate obscuration and multipath effects caused, for example, from surrounding buildings in static or moving scenarios.

The [Figure 8-4](#) is an example of a receiver placed in a car driving on a street. You can define various test scenarios, including the particular moving behavior and surrounding buildings. Buildings are defined with their height and the distance to the receiver, and the material they are built from.

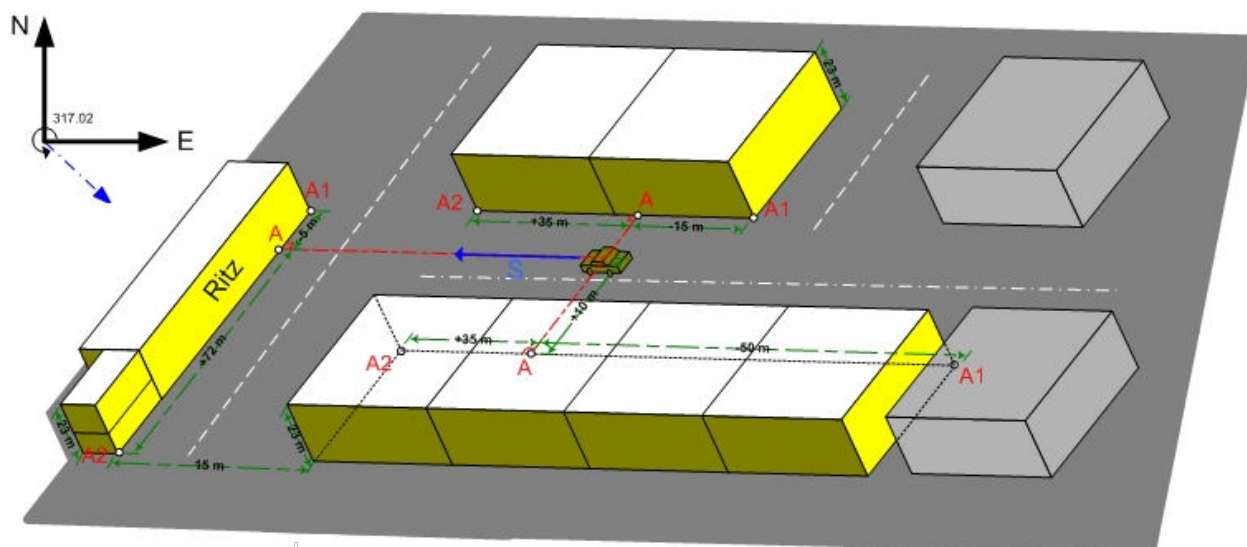

Figure 8-4: Example: Vertical obstacles for simulation of obscuration and multipath from surrounding buildings

Understanding the simulation of obscuration and multipath effects

On signal generation start, the software selects an optimal satellites constellation based on the enabled GNSS systems and SV selection configuration, like maximum number of satellites per GNSS system. A line-of-sight propagation (LOS view) is assumed in the first stage and the satellites constellation is selected to fulfill the selected visibility criteria, for example HDOP/PDOP. Only now, the selected constellation is filtered by the selected environment model and the obscuration and multipath effects are applied on the satellite constellation. The satellite constellation is constantly proved and a satellite handover is performed automatically. Handover is performed whenever a new satellite appears or because of the receiver's movement profile, a satellite is not anymore obscured.

Internal sampling rate

The R&S SMW200A uses different sample rate on environment model depending whether only obscuration or the combination of obscuration and automatic multipath is simulated. For example, the sampling rate of the model "Urban Canyon" is 10 Hz if only obscuration is enabled and 5 Hz in the other case.

Creating your own environmental model

You can select from the predefined models, adjust their settings and customize them or if you prefer create your own models. User-defined model can be loaded as files or created internally. In the latter case, you create the model as a table, where each row corresponds to an object that causes obscuration, reflection of the signal and/or multipath effects.

The following functions help you further and simplify and accelerate the configuration:

- *WYSWYG graphical view*: visualizes the objects that you create and indicate each object by its row index.

- *Subset of predefined but customizable user environment models*: suitable as templates for creation of user-defined models.
Provided are suburban area, urban canyon, tunnel, bridge, highway, etc.
- *Interface for file handling*: enables loading files created with this or third-party software or saving user-defined configuration
- Settings for joint obstacle's configuration: for defining of a subset of obstacles and automatically repeating the configured subset.

Visualizing the obscured satellites

Environmental models are applied on the current satellite's constellation and for the selected receiver's position. Satellites that are invisible at that position are not simulated. Other satellites are simulated as obscured or as having echoes. The signal of some others can be simulated with a power attenuation due to antenna pattern response.

To visualize the satellite's constellation at any given simulation moment, select "Receiver" > "Simulation Monitor" and observe the "Display" > "Sky View".

Built-in environment models

Provided are the following types of predefined environment models:

- City block
The model assumes: average building height 20m
- Urban canyon
Correspond to an urban canyon in commercial city places.
The model assumes: street width 30m, average building height 30m, gap between the buildings along a street 10m, street length 1200m
- Suburban area
The model assumes: relatively high distance between the GNSS receiver and the main reflecting obstacles
- Cutting
The model assumes: obscuration effects from side barriers on the left and right of a vehicle moving on a highway
- Highway
The model assumes: effects of the barriers and cars moving in the opposite lines and then interrupting the GNSS signal for a short time in a periodic way

Details and availability

[Table 8-1](#) provides an overview of the environment models, their availability depending on the receiver's type and their applicability for the different vehicle types.

Table 8-1: Supported environment models

Environment model	Receiver types	Moving position	Static position	Model description
Line of sight (LOS)	all	x	x	Near field environment is not defined.
Vertical obstacles	Pedestrian Land vehicle	x	x	<p>Simulates the whole fix geometry of many objects (locations) to the left, right, front and back of the user's static location and is suitable for city block simulation.</p> <p>The objects are defined relative to the map orientation, i.e to the street orientation. The map is built on the OX and OY axes and any point on the map can be defined as a reference point. Each object is defined with its length and its distance to this reference point.</p> <p>The receiver's position is configurable and defined as an offset to the reference point.</p> <p>See Chapter 8.7.2, "Vertical obstacles", on page 134.</p>
Roadside planes	Pedestrian Land vehicle	x		<p>Describes an environment where the user-defined obstacles representing roadside planes or surfaces built from different materials are located to the left and/or to the right side of the receiver. The roadside planes are assumed parallel to the motion of the vehicle.</p> <p>See Chapter 8.7.3, "Roadside planes", on page 138.</p>
Full obscuration	Pedestrian Land vehicle Ship	x	x	<p>Defines areas with configurable size in that the satellite signals are completely obscured.</p> <p>See Chapter 8.7.4, "Full obscuration", on page 143.</p>
Ground/sea reflection	Ship Aircraft Spacecraft	x	x (ship only)	<p>Simulated is ground/sea reflection and obscuration of satellites due to modeled canyon obstacles (left and right) with configurable distance to vehicle, height and surface type with different properties.</p> <p>Use this model to simulate flights over sea/lakes with surrounding canyon or for ships crossing sea straits.</p> <p>See Chapter 8.7.5, "Ground/sea reflection", on page 146.</p>
Static multipath	all	x	x	See Chapter 8.7.6, "Static multipath" , on page 148.

8.4 Supported multipath models

Multipath is a term describing the situation when the satellite's signal reaches the receiver via two or more paths. The direct signal path is referred as the line-of-sight (LOS) signal, whereas the reflected paths are called echoes. Multipath propagation affects the accuracy of the pseudorange measurements.

The severity of the multipath propagation effect depends mainly on the following:

- The signal strength of the echoes
- The delay between the LOS component and the echoes

In R&S SMW200A you can define static multipath effects per satellite, see [Chapter 8.7.6, "Static multipath"](#), on page 148. The multipath model describing the static multipath propagation is implemented as a tapped delay model. It enables you to configure a LOS component and up to 10 echoes per SV ID.

8.5 Simulating real-world effects

Simulating rel-world effects covers the following topics:

- [Simulating antenna patterns and body masks](#)..... 114
- [Creating multipath environment scenarios](#)..... 122
- [Creating obscured environment scenarios](#)..... 124

8.5.1 Simulating antenna patterns and body masks

This chapter covers the following topics:

- ["To load an antenna pattern/body mask file"](#) on page 114
- ["To simulate antenna pattern"](#) on page 115
- ["To change the antenna pattern"](#) on page 118
- ["To prepare for automotive applications"](#) on page 119
- ["To modify antenna attenuation and phase values"](#) on page 120
- ["To create an antenna pattern/body mask file"](#) on page 121

To load an antenna pattern/body mask file

1. Select "GNSS" > "GNSS Configuration" > "Receiver".
2. Select "Antenna Configuration".

The default configuration uses one isotropic antenna in an open sky environment:
 "Body Mask" > "OpenSky", "Antenna Pattern" > "Isotropic"

	Active	Body Mask	Antenna Pattern	ΔX (m)	ΔY (m)	ΔZ (m)	Δ Heading (deg)	Δ Elevation (deg)	Δ Bank (deg)
A1 >	<input checked="" type="radio"/>	OpenSky	Isotropic	0.000	0.000	0.000	0.000	0.000	0.000

3. To select a body mask file, proceed as follows:
 - a) Select "A1" > "Body Mask" > "Open Sky".
A standard file-select dialog opens and displays list of available files and the content of the selected file.
 - b) Select "Predefined Files" or "User Files".
 - c) To load the file, confirm with "Select".
4. To select an antenna pattern file, proceed as follows:
 - a) Select "A1" > "Antenna Pattern" > "Isotropic".
A standard file-select dialog opens and displays list of available files and the content of the selected file.
 - b) Select "Predefined Files" or "User Files".

c) To load the file, confirm with "Select".

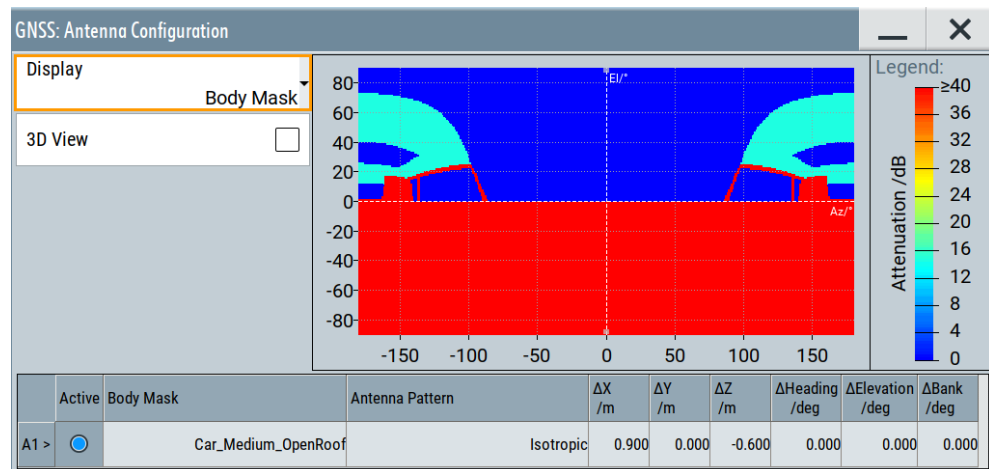

The display is color-coded, where different power/attenuation or phase responses between satellite carrier and receiver antenna are indicated with different colors (see "Legend"). The vertical axis displays the elevation, the horizontal axis the azimuth.

With a selected antenna pattern, the R&S SMW200A simulates the satellite power and carrier phase depending on the antenna pattern and attitude parameters.

To simulate antenna pattern

1. Select "GNSS" > "General" > "Set To Default".
2. Select "Test Mode" > "Navigation".
3. Select "GNSS Configuration" > "Systems & Signals", for example, to activate a hybrid GNSS constellation:
 - a) Select "GNSS" > "GPS"/"Galileo"/"GLONASS" > "On".
 - b) Select "L1 Band" > "On".
4. Select "GNSS Configuration" > "Receiver" > "Position" > "Moving".
5. Select a waypoint file, for example, the file `Munich_Flight` with file extension `*.xtd`:
Select "Position Configuration" > "Waypoint File" > "Munich_Flight".
6. Select "Attitude Behaviour" > "Spinning".
7. Select "More" > "Spinning Rate" > "0.1 Hz".
8. Select "Receiver" > "Number of Antennas" > "3".
9. Select "Receiver" > "Antenna Configuration".
10. For all antennas "Ax", select one of the predefined files, for example, `Space_Vehicle_3_antennas` with file extension `*.ant_pat`:
Select "Ax" > "Body Mask" > "Space_Vehicle_3_antennas".
11. Observe the 3D positioning of the three antennas:

- a) Select "Display" > "Position".
- b) Select "3D View" > "On".

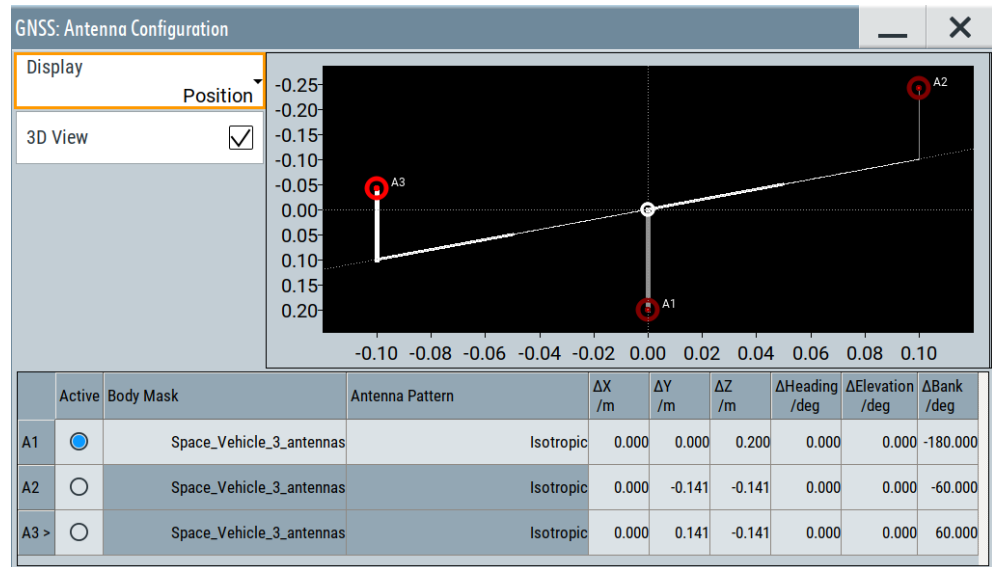

The diagram displays the position of the antennas via their distance to the center of gravity that is the position of the GNSS receiver. A cartesian coordinate system (X, Y, Z) defines the position via the deviation to origin (" ΔX ", " ΔY ", " ΔZ ").

Tip:

See also:

- [Chapter 8.5.1, "Simulating antenna patterns and body masks"](#), on page 114
- [Example"Antenna with four sectors"](#) on page 663

- 12. To activate signal generation, select "GNSS" > "General" > "State" > "On".
- 13. Select "Simulation Monitor" > "Display" > "Sky View".

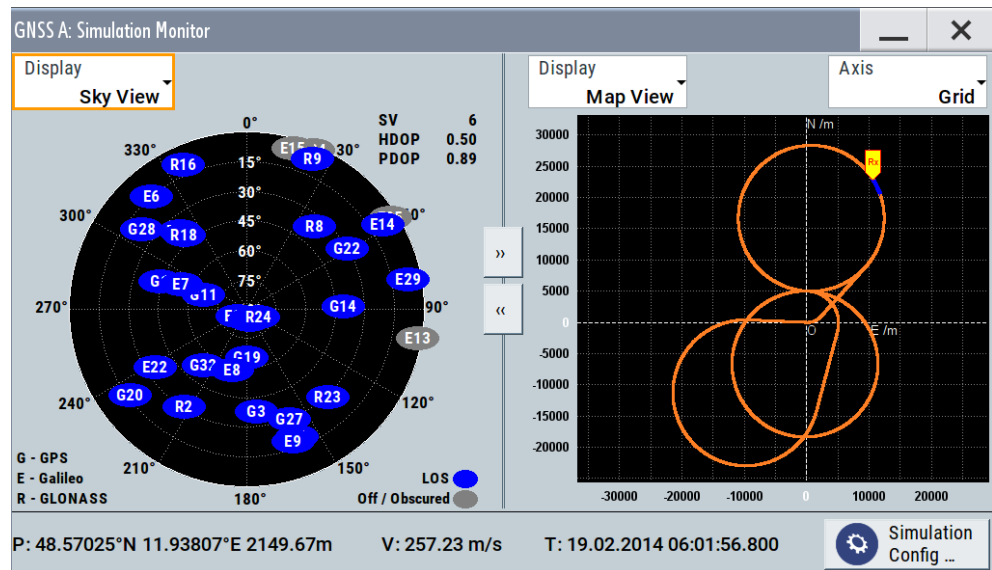

The simulation updates the sky view and map view in real time. Observe GNSS signal changes due to satellite visibility changes, spinning rate changes or currently active antennas.

14. Select "Display" > "Power View".

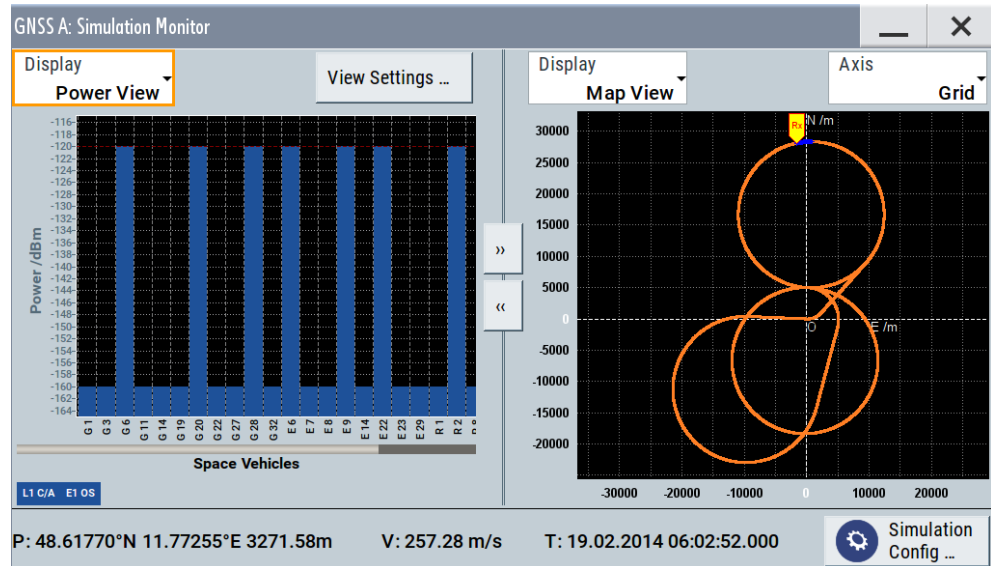

The simulation updates the power levels of the space vehicles in real time. The body mask of the active antenna causes a 40 dB attenuation of the power level of the space vehicle. Also, the attenuation depends on the GNSS receiver position and orientation towards the direction of the signal of the space vehicles.

15. Select "Display" > "Attitude View".

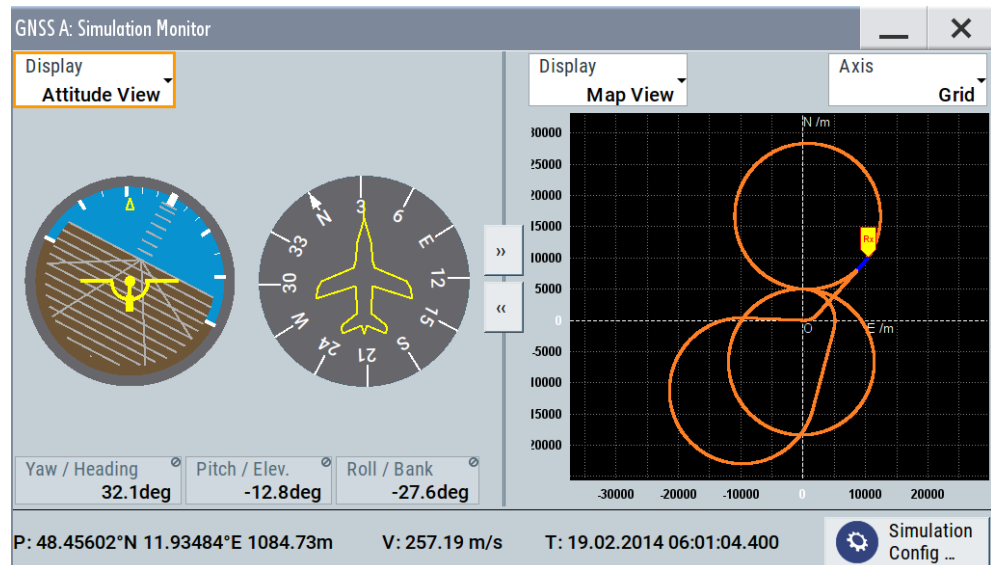

The attitude indicator confirms the enabled spinning.

To change the antenna pattern

We assume that you loaded an antenna pattern, see "To load an antenna pattern/body mask file" on page 114.

1. Select "GNSS Configuration" > "Receiver".
2. Select, for example, "Number of Antennas" > "2".
3. Select "Antenna Configuration".
The second antenna appears in the table of the "Antenna Configuration" dialog.
4. Select "Display Type" > "Position".
5. Specify antenna position parameters " ΔX ", " ΔY " and " ΔZ " for each antenna.
" ΔX ", " ΔY " and " ΔZ " are the deviations from the center of gravity (COG)
6. Specify antenna attitude parameters " Δ Heading", " Δ Elevation" and " Δ Bank" for each antenna.

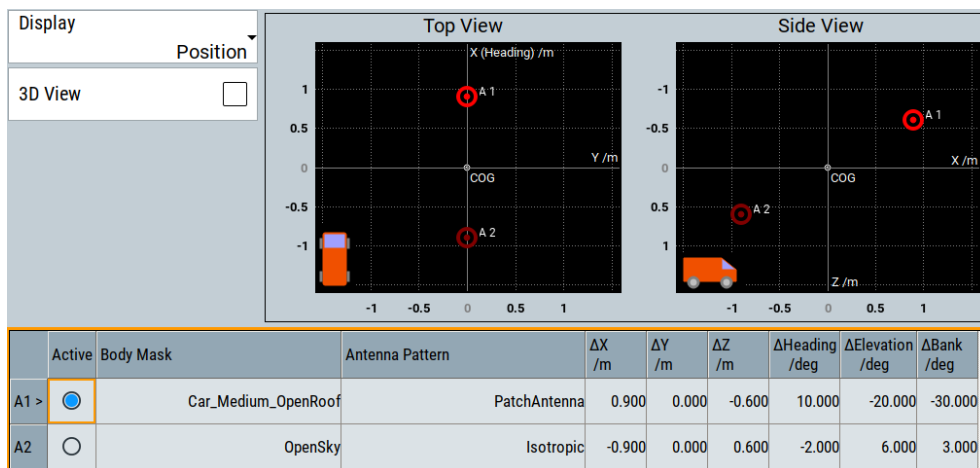

The diagram displays the position in top view (in direction of the z-axis) and from side view (in direction of the y-axis).

7. To visualize the antenna location on 3D view, proceed as follows:
 - a) Select "3D View" > "On".
 - b) To define the simulated antenna, select, for example, "A1" > "Active".

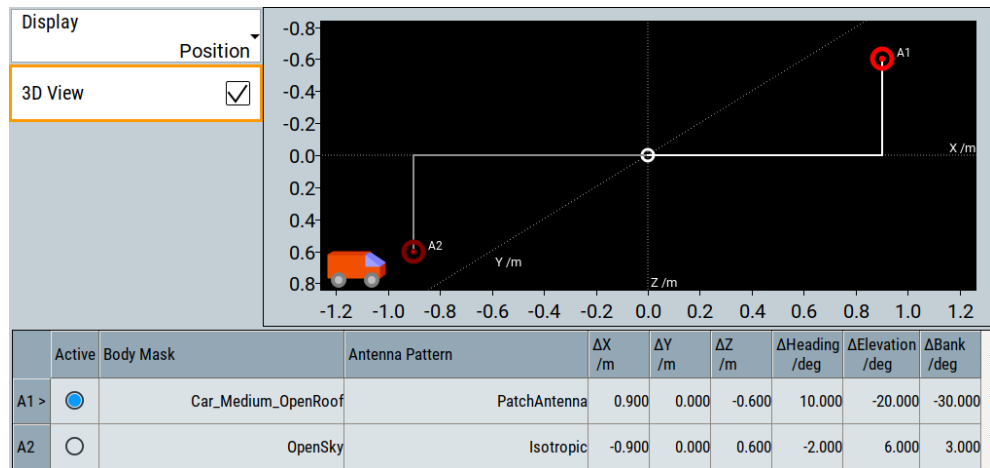

Bars visualize the antenna position displaying the distance to origin that is the COG. Also, the diagram highlights the simulated antenna "A1".

8. Select "Display" > "Antenna Pattern (Attenuation)"/"Antenna Pattern (Phase)" to visualize the attenuation and phase response of the simulated antenna.

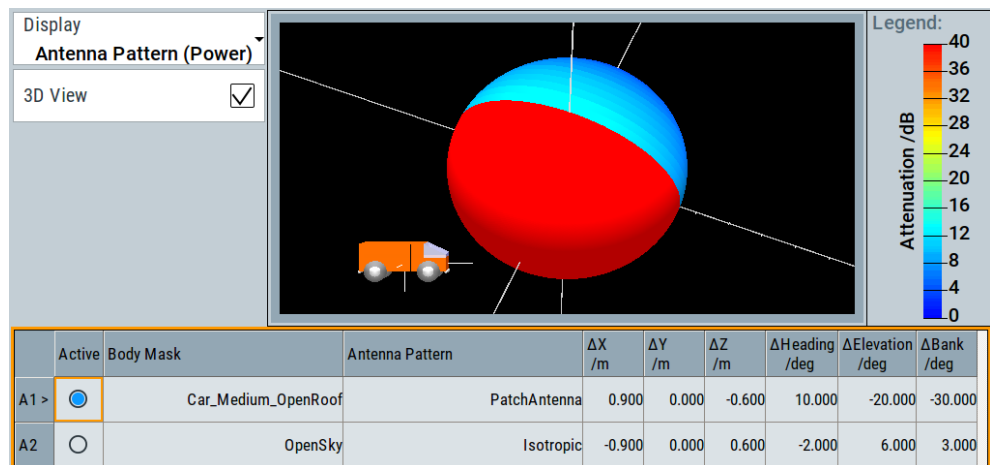

The display visualizes the orientation of the simulated antenna, which results from the attitude setting compared to the COG. The power/attenuation response as defined in the antenna pattern file is also displayed (see "Legend").

To prepare for automotive applications

Extract the attitude parameters from the waypoint file as follows:

1. Select "Receiver" > "Position" > "Moving".
2. Select "Position Configuration" > "Attitude Behaviour" > "From Waypoint File".

To modify antenna attenuation and phase values

We assume that you have performed the steps 1 to 4 a) or 4 b) described in ["To load an antenna pattern/body mask file"](#) on page 114. The procedures for modifying antenna pattern and body mask files are the same. The following procedure describes the steps for modifying an antenna pattern only.

1. Select "Edit" to edit the antenna pattern file.

The "Edit Antenna Pattern File - *" dialog opens. The display is color-coded, where different attenuation values or phase values between satellite carrier and receiver antenna are indicated with different colors (see "Legend"). The vertical axis displays the elevation, the horizontal axis the azimuth.

For body mask files, the "View Type" > "Attenuation" is available only.

2. Select, for example the "View Type" > "Attenuation" to modify attenuation values.
3. Change the "Resolution" of the display matrix:
 - Select, for example, "Resolution" > "1°" for fine editing.
 - Select, for example, "Resolution" > "30°" for coarse editing.
4. In the graph, use the mouse to drag a rectangular area, to modify the attenuation of this area.

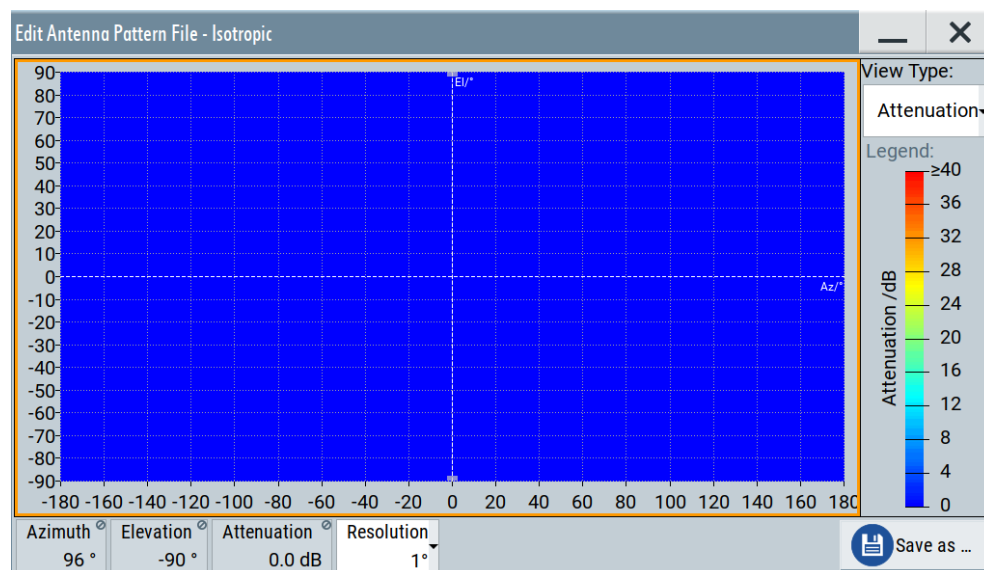

5. Left mouse click into the rectangular area to access the context menu and select "Edit Selection".
Set the "Attenuation" value.

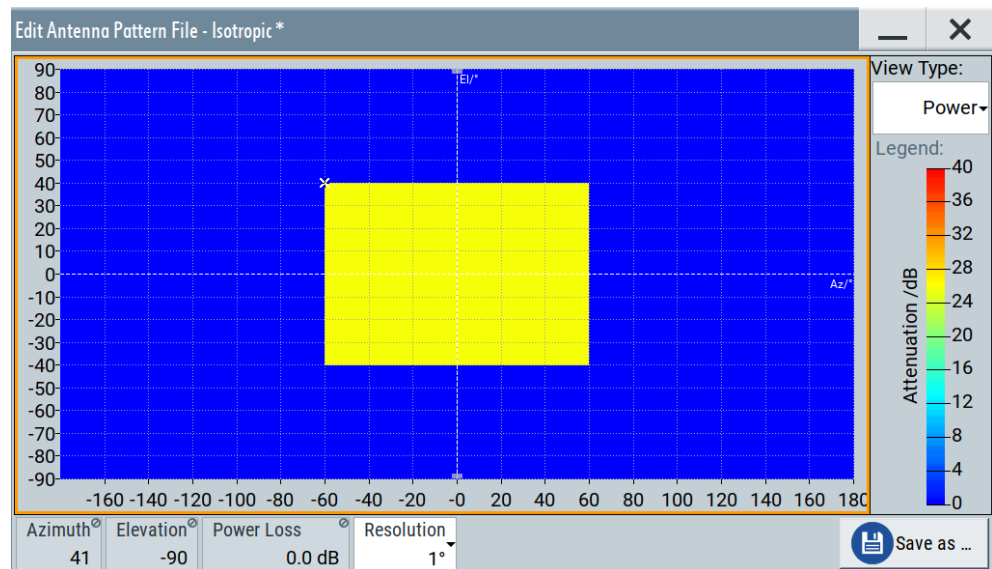

6. To zoom into an area: select a rectangular area.- In the context menu. Select "Zoom Into Selection".
Displayed is only the selected area. Values outside this area are still valid. The "Resolution" does not change.
7. Right mouse click, to zoom out.
8. For editing phase differences, repeat [steps 4 and 5](#).
9. To save the antenna pattern into a file:
 - a) Select "Save as".
 - b) Enter a filename.
 - c) Select "Save".

To create an antenna pattern/body mask file

Three files describe an antenna, the body mask *.body_mask file, the antenna pattern *.ant_pat file and the phase response *.phase file. The latter two files must have the same filename and must be saved in the same directory. The *.ant_pat file describes the power response matrix of each antenna.

To create your own antenna pattern/body mask files from xml data:

1. Open a text editor.
2. To create an antenna pattern file for example, follow the *.ant_pat file [format specification](#):
 - a) Specify <xml version> and <encoding> ISO type.
 - b) Define the file content in the <antenna_pattern> container.
 - c) Specify the description for each antenna in the <antenna_description> subcontainer: Number of antennas, position and attitude shift parameters compared to the center of gravity.

- d) Set the azimuth `<az_res>` and elevation `<elev_res>` resolution, which specify the length of the columns and rows in the `<data>` container.
 - e) In the `<data>` container, specify the power/attenuation or phase response values of the antenna pattern.
3. To save the antenna pattern file and save it on the instrument's hard disk:
 - a) Enter a filename with extension `.ant_pat`.
 - b) Save the file locally on your PC.
 - c) Use one of the standard file transfer methods to transfer the file to the hard disk of the R&S SMW200A.
 - d) Save the file, for example, in the standard user files directory:
`/var/user/gnss/antenna_patterns`
 4. To load the antenna pattern file on the R&S SMW200A user interface, perform the step 4 in ["To load an antenna pattern/body mask file"](#) on page 114.

See also:

- [Chapter 8.6, "Antenna and body mask settings"](#), on page 125
- [Chapter A.3, "Antenna pattern and body mask files"](#), on page 663

8.5.2 Creating multipath environment scenarios

To simulate static multipath propagation for one space vehicle

1. Select "GNSS" > "GNSS Configuration" > "Receiver".
2. Select "Environment Model" > "Static Multipath".
3. Select "Environment Configuration".
 The "Environment Configuration" dialog opens. It allows you to configure multipath propagation for each GNSS and space vehicle.
4. Specify GNSS and space vehicle.
 - a) Select, for example, "System" > "GPS".
 - b) Select, for example, "SV-ID" > "1".
5. Specify the number of signal components, that define the multipath propagation:
 - a) Select the number of echoes, for example, "Number of Echoes" > "1".
 - b) To simulate an obscured direct signal path between space vehicle and receiver, disable the LOS component, "Line of Sight (LOS)" > "Off".
 This procedure assumes "Line of Sight (LOS)" > "On" that means there are two components (one echo and LOS), that contribute to the received GNSS signal.
6. Specify characteristics of the echo signal, for example, as follows:
 - a) Set "Initial Code Phase" > "1000 m".

- b) Set "Code Phase Drift" > "50 m/s".
The application calculates the "Doppler Shift" automatically. Calculation includes the code phase drift and the center frequency of the RF band, here "L1".
- c) Set "Power Offset" > "-3 dB".
The echo signal is attenuated by 3 dB compared to the LOS signal.
- d) Set "Initial Carrier Phase" > "1 m".
- e) Optionally, correct the "Doppler Shift" and the reference RF band.
If corrected, the application readjusts the "Code Phase Drift" as described in step b).
- f) Set angle of arrival for elevation and azimuth, "AoA Elev." > "1 rad" and "AoA Azimuth" > "1 rad".

The graph to the right visualizes the configuration displaying the LOS component and echoes. Plotted is the power of the space vehicle (y-axis) versus the initial code phase (x-axis) of each signal component. The LOS power has reference power/power offset of 0.0 dB.

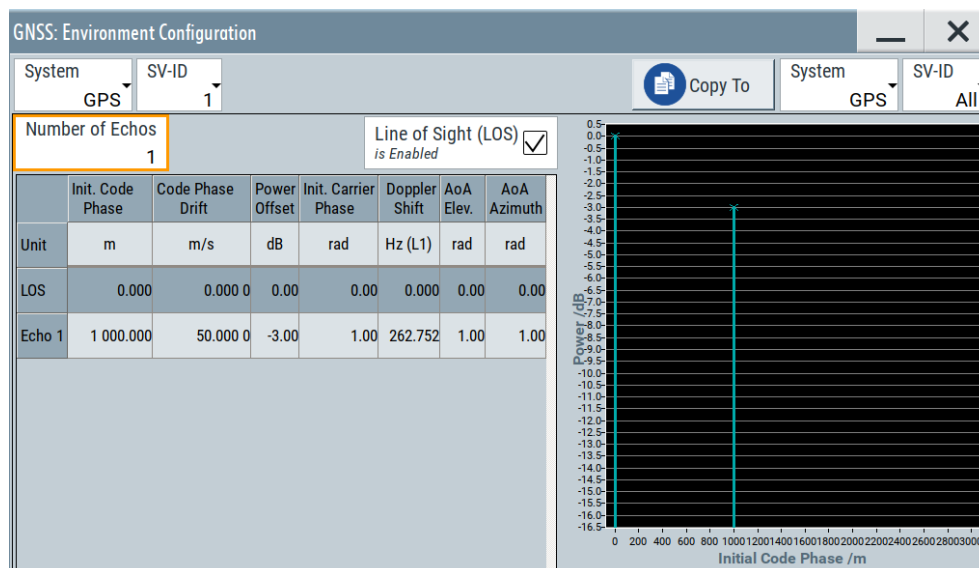

Figure 8-5: Static multipath configuration for GPS space vehicles

- 7. Optionally, you can apply the configuration to other GNSS and space vehicles, for example, as follows:
 - a) Set "System" > "GPS".
 - b) Set "SV-ID" > "All".

All GPS space vehicles have the same static multipath configuration comprising a LOS component and one echo.
- 8. Select "GNSS" > "State" > "On".
The R&S SMW200A generates the GNSS signal of satellite signals that experience static multipath propagation.

- Monitor LOS and echo signal components in the simulation monitor in "Display" > "Sky View" and "Display" > "Power View".

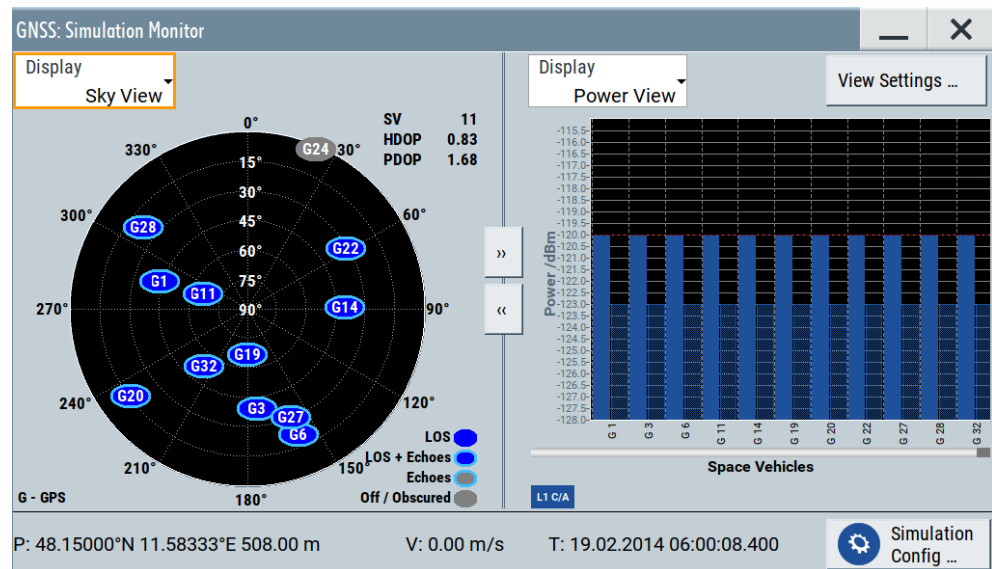

Figure 8-6: Monitoring effects of static multipath configuration for GPS space vehicles

8.5.3 Creating obscured environment scenarios

See:

- "To simulate vertical obstacles" on page 124
- "To simulate roadside planes" on page 124
- "To simulate full obscuration" on page 125
- "To simulate ground reflections or sea reflections" on page 125

To simulate vertical obstacles

1. Select "GNSS" > "GNSS Configuration" > "Receiver".
2. Select "Environment Model" > "Vertical Obstacles".
3. Select "Environment Configuration".

The "Environment Configuration" dialog opens. It allows you to configure vertical obstacles parallel to the receiver trajectory.

To simulate roadside planes

1. Select "GNSS" > "GNSS Configuration" > "Receiver".
2. Select "Position" > "Moving".
3. Select "Environment Model" > "Roadside Planes".
4. Select "Environment Configuration".

The "Environment Configuration" dialog opens. It allows you to configure roadside planes parallel to the receiver trajectory.

To simulate full obscuration

1. Select "GNSS" > "GNSS Configuration" > "Receiver".
2. Select "Environment Model" > "Full Obscuration".
3. Select "Environment Configuration".

The "Environment Configuration" dialog opens. It allows you to configure fully obscured environment of a receiver.

To simulate ground reflections or sea reflections

1. Select "GNSS" > "GNSS Configuration" > "Receiver".
2. Select "Environment Model" > "Ground/Sea Reflection".
3. Select "Environment Configuration".

The "Environment Configuration" dialog opens. It allows you to configure ground/sea reflection, that airborne receivers experience.

8.6 Antenna and body mask settings

Option: R&S SMW-K108

Access:

1. Select "GNSS > Simulation Configuration > Receiver".
2. Set the number of simulated antennas, for example, "Number of Antennas = 2".

Try out also the following:

1. In the "Antenna Configuration" dialog, select "3D View > On".
2. Select "Display > Antenna Pattern (Power)/(Phase)" to visualize the power and phase response.
3. Select "Display > Position" to visualize the antenna's orientation and location compared to the center of gravity (COG).

Automotive applications

Extract the attitude parameters from the waypoint file as follows:

1. Select "Receiver > Position > Moving".
2. Select "Position Configuration > Attitude Behaviour > From Waypoint File".

Settings:**8.6.1 Antenna configuration settings**

Access:

1. Select "GNSS > Simulation Configuration > Receiver".
2. Set the number of simulated antennas, for example, "Number of Antennas = 2".
3. Select "Antenna Configuration".

The dialog provides a graphical display of antenna characteristics and settings to select the simulated antenna.

Antenna characteristics

1. Select "Display > Body Mask".
The default configuration uses favorable conditions: isotropic antennas in open sky environment.
2. For tests in a more challenging environment, perform the following for each antenna:
 - a) To select a body mask description file, select "A# > Body Mask > Open Sky > Select Antenna Pattern File > Predefined/User Files".
 - b) To select the antenna pattern file, select "A# > Antenna Pattern > Isotropic > Select Antenna Pattern File > Predefined/User Files".
 - c) Confirm with "Select".

The "Select Antenna Pattern File" displays both, a list of available files and the content of the selected file.

3. To define which antenna is simulated, for example the "A1" antenna:
 - a) Select "A1" > "Active".
 - b) Option: R&S SMW-B9
In "System Config > Mode > GNSS Advanced", select the antenna "Stream# > A1".

Note: Switching between the active antenna restarts the simulation.

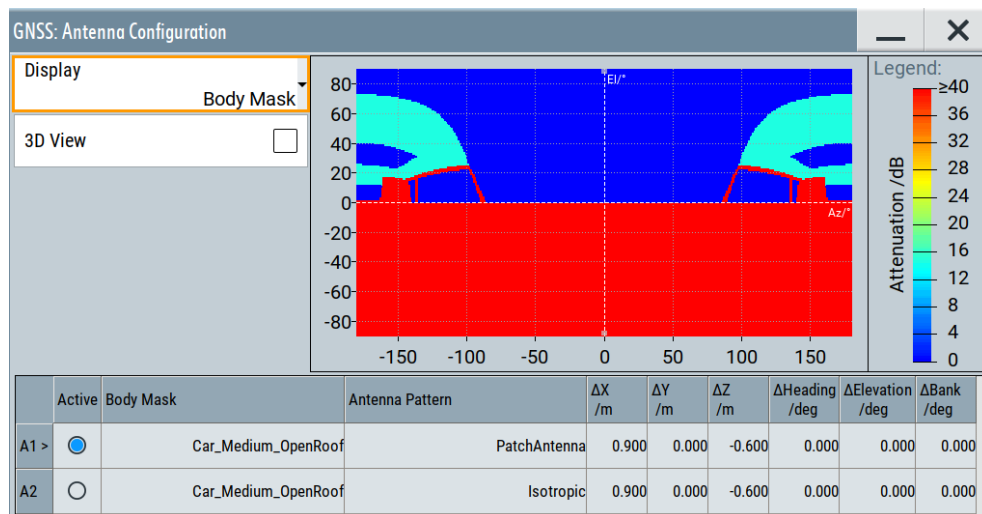

The display is color coded, where the different power levels are indicated with different colors (see "Legend").

Three files describe an antenna, the body mask *.body_mask file, the antenna pattern *.ant_pat file and the phase response *.phase file. The latter two files must have the same filename and must be saved in the same directory. The *.ant_pat file describes the power response matrix of each antenna.

With a selected antenna pattern, the R&S SMW200A simulates the satellite power and carrier phase depending on the antenna pattern and attitude parameters.

Number of Antennas..... 127

Display..... 127

3D View..... 128

A x..... 128

Active..... 128

Body Mask, Antenna Pattern..... 128

Delta X, Delta Y, Delta Z..... 129

Delta Heading, Delta Elevation, Delta Bank..... 129

Number of Antennas

Defines the number of configurable antennas.

You can create a pool of up to four antenna and body masks and switch between them. To define which antenna is simulated, set "A#" > "Active".

Note: Switching between the active antenna restarts the simulation.

Remote command:

[:SOURce<hw>] :BB:GNSS:RECeiver [:V<st>] :ANTenna:COUNT on page 390

Display

Select the antenna characteristics that are currently visualized.

If more than one antenna is enabled (e.g. "Receiver > Number of Antennas = 2"), the displayed information corresponds to the currently selected one ("A# > Active > On").

The graph is merely a visualization. To change the values, select "A# > Filename > Select Antenna Pattern File > Predefined/User Files" > **"Edit"**.

"Position" Two displays that visualize the antenna position relative to the center of gravity (COG):

- On the left, the top view - shows the x/y direction.
- On the right, the side view - shows the x/z direction.

To change the antenna position, set the parameters " ΔX , ΔY , ΔZ ".

"Body Mask" Visual representation of the body mask retrieved from the selected file ("Body Mask").

"Antenna Pattern (Attenuation), Antenna Pattern (Phase)"
Visual representation of the attenuation/phase distribution as retrieved from the selected antenna pattern file ("Antenna Pattern").

Remote command:

```
[ :SOURCE<hw> ] :BB:GNSS:RECeiver [ :V<st> ] :ANTenna:DISPlay on page 391  
[ :SOURCE<hw> ] :BB:GNSS:RTK:BASE<ch>ANTenna:DISPlay
```

3D View

Displays an interactive 3D representation of the body mask or the power/phase distribution the antenna.

Remote command:

```
[ :SOURCE<hw> ] :BB:GNSS:RECeiver [ :V<st> ] :ANTenna:V3D on page 391
```

A x

Subsequent antenna number. It also selects the antenna whose pattern or body mask is visualized.

Active

- In "System Config > Mode > Standard", activates the antenna and thus defines which antenna is simulated.
- Option: R&S SMW-B9
In "System Config > Mode > GNSS Advanced", select "Stream# > A1" to define which antenna is simulated by which stream.

Remote command:

```
[ :SOURCE<hw> ] :BB:GNSS:RECeiver [ :V<st> ] :A<ch>:STATE on page 392  
[ :SOURCE<hw> ] :BB:GNSS:RTK:BASE<st>:A<ch>:STATE on page 400
```

Body Mask, Antenna Pattern

Displays the selected body mask and antenna pattern files.

To change a file, select its filename.

You access the standard "Select Antenna Pattern File" dialog to select (or edit) the file, describing the body mask or the antenna pattern (*.ant_pat and *.body_mask). Several predefined antenna patterns are provided but you can load your own files ("User Files"), too.

The "Select Antenna Pattern File" displays both, a list of available files and the content of the selected file.

Select "Edit" to open a graphical editor for changing the file content.

See:

- [Edit > Body Mask/Antenna Pattern File](#)
- [Chapter A.3, "Antenna pattern and body mask files"](#), on page 663.

Remote command:

[\[:SOURCE<hw>\]:BB:GNSS:APATtern:CATalog:PREDeFined?](#) on page 391
[\[:SOURCE<hw>\]:BB:GNSS:APATtern:CATalog:USER?](#) on page 391
[\[:SOURCE<hw>\]:BB:GNSS:RECeiver\[:V<st>\]:A<ch>:APATtern:FILE](#)
 on page 392
[\[:SOURCE<hw>\]:BB:GNSS:BODY:CATalog:PREDeFined](#) on page 391
[\[:SOURCE<hw>\]:BB:GNSS:BODY:CATalog:USER](#) on page 391
[\[:SOURCE<hw>\]:BB:GNSS:RECeiver\[:V<st>\]:A<ch>:BODY:FILE](#) on page 392
[\[:SOURCE<hw>\]:BB:GNSS:RTK:BASE<st>:A<ch>:APATtern:FILE](#) on page 399
[\[:SOURCE<hw>\]:BB:GNSS:RTK:BASE<st>:A<ch>:BODY:FILE](#) on page 399

Delta X, Delta Y, Delta Z

Sets an offset relative to the center of gravity (COG) to place the antenna.

Remote command:

[\[:SOURCE<hw>\]:BB:GNSS:RECeiver\[:V<st>\]:A<ch>:DX](#) on page 393
[\[:SOURCE<hw>\]:BB:GNSS:RECeiver\[:V<st>\]:A<ch>:DY](#) on page 393
[\[:SOURCE<hw>\]:BB:GNSS:RECeiver\[:V<st>\]:A<ch>:DZ](#) on page 393
[\[:SOURCE<hw>\]:BB:GNSS:RTK:BASE<st>:A<ch>:DX](#) on page 400
[\[:SOURCE<hw>\]:BB:GNSS:RTK:BASE<st>:A<ch>:DY](#) on page 400
[\[:SOURCE<hw>\]:BB:GNSS:RTK:BASE<st>:A<ch>:DZ](#) on page 400

Delta Heading, Delta Elevation, Delta Bank

Displays the information on the antenna orientation and tilt.

Remote command:

[\[:SOURCE<hw>\]:BB:GNSS:RECeiver\[:V<st>\]:A<ch>:DHEading](#) on page 392
[\[:SOURCE<hw>\]:BB:GNSS:RECeiver\[:V<st>\]:A<ch>:DELevation](#)
 on page 392
[\[:SOURCE<hw>\]:BB:GNSS:RECeiver\[:V<st>\]:A<ch>:DBANK](#) on page 392

8.6.2 Edit body mask and antenna pattern settings

To edit body mask files

1. Select "Antenna Configuration > A# > Body Mask > Open Sky".
The dialog "Select Body Mask File" opens.
2. Select the body mask file that you want to edit.
 - a) Select a body mask file between from a list in the tabs "User Files", "Predefined Files" or "Recent Files".
For example, select "Predefined Files > OpenSky".

b) Select "Edit".

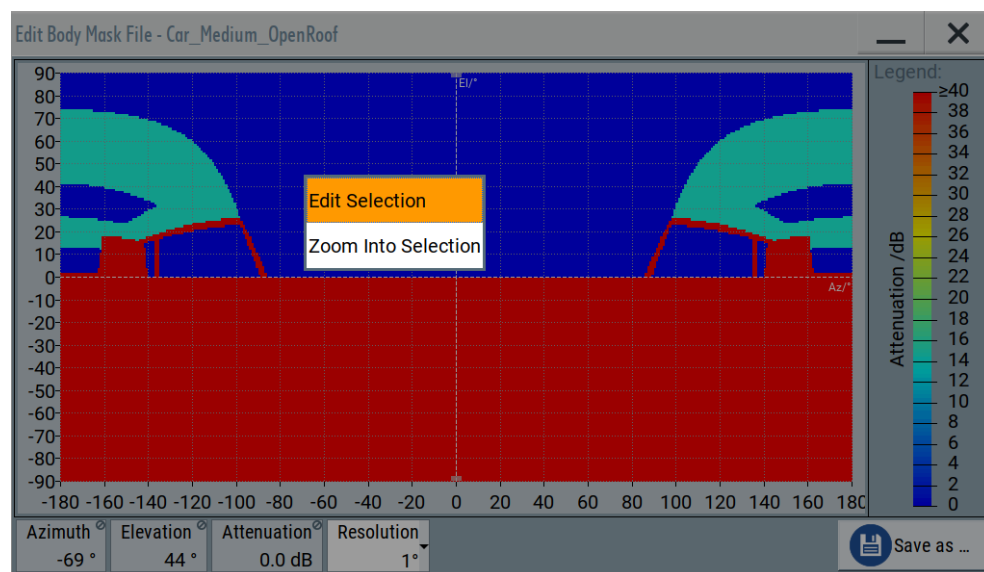

The "Edit Body Mask File" dialog of the selected file opens. It provides settings to configure resolution and attenuation for a two-dimensional grid diagram of the body mask. Also, it displays azimuth, elevation and attenuation for each grid point. You can also zoom into the grid areas for fine-tuning.

Masked areas and antenna patterns with attenuation values of 40 dB and higher imply, that the satellites are fully obscured in the masked direction. In the simulation monitor, these satellites are grey in the "Sky View".

To edit antenna pattern files

1. Select "Antenna Configuration > A# > Antenna Pattern > Isotropic".

The dialog "Select Antenna Pattern File" opens.

2. Select the antenna pattern file that you want to edit.

a) Select an antenna pattern file between from a list in the tabs "User Files", "Pre-defined Files" or "Recent Files".

For example, select "Predefined Files > PatchAntenna".

b) Select "Edit".

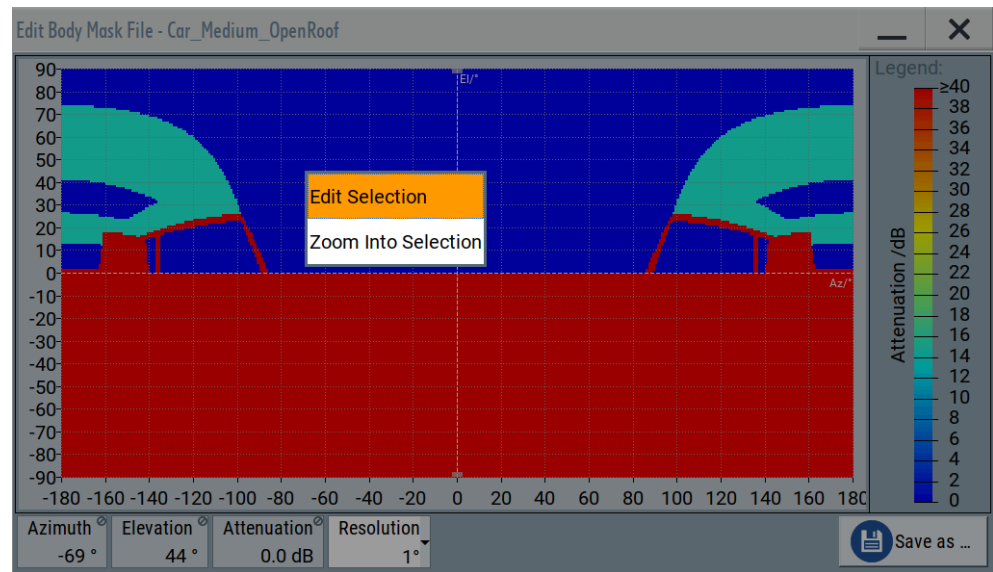

The "Edit Antenna Pattern File" dialog of the selected file opens. It provides settings to configure resolution, attenuation and phase relations for a two-dimensional grid diagram of the antenna pattern. Also, it displays azimuth, elevation and attenuation for each grid point. You can also zoom into the grid areas for fine-tuning.

Masked areas and antenna patterns with attenuation values of 40 dB and higher imply, that the satellites are fully obscured in the masked direction. In the simulation monitor, these satellites are grey in the "Sky View".

Edit > Body Mask/Antenna Pattern File.....	131
View Type.....	132
Azimuth, Elevation, Attenuation, Phase, Resolution.....	132
Save as.....	132

Edit > Body Mask/Antenna Pattern File

Access: "Antenna Configuration > A# > Body Mask > Open Sky > Select Antenna Pattern File > Predefined/User Files", select the body mask description file and select "Edit".

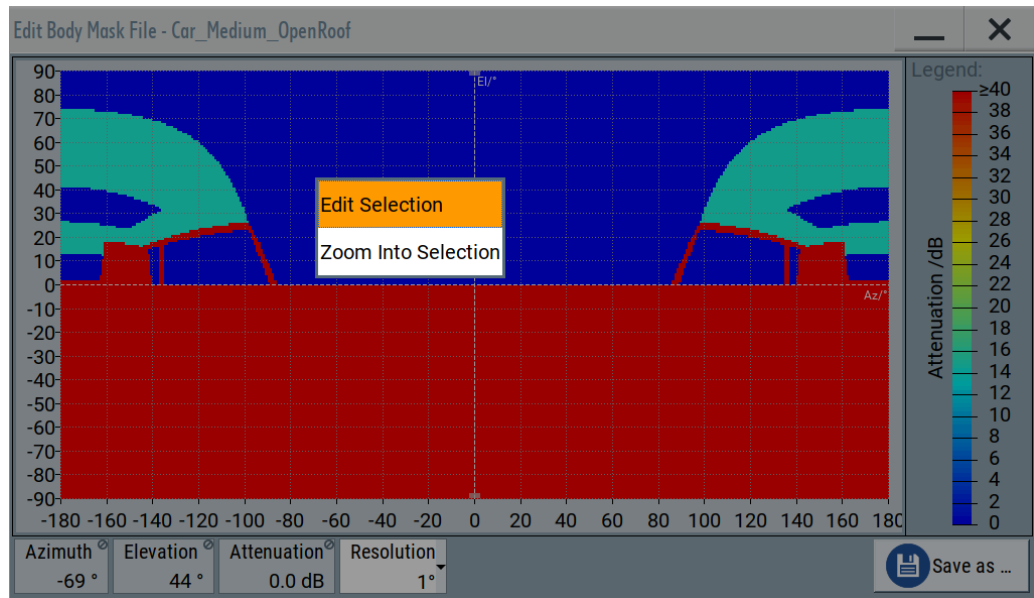

In this dialog you can change the file content, e.g. attenuation values, and zoom in into display areas.

View Type

Toggles between the phase and power representation.

Works like "Display > Antenna Pattern (Attenuation)" and "Antenna Pattern (Phase)".

Azimuth, Elevation, Attenuation, Phase, Resolution

Displays the corresponding values of the selected point on the attenuation/phase graph.

To edit the values, select an area on the graph, left mouse click and select "Edit Selection". Also you can configure the resolution for high or low granularity antenna patterns.

Save as

Accesses the standard "File Select" dialog to save the antenna pattern or body mask as a file. The predefined files cannot be overwritten. If a predefined file has been changed, save it with a new filename.

Remote command:

n.a.

8.7 Environment configuration settings

Option: R&S SMW-K108

- [Environment model and configuration](#).....133
- [Vertical obstacles](#)..... 134
- [Roadside planes](#)..... 138

- [Full obscuration](#)..... 143
- [Ground/sea reflection](#)..... 146
- [Static multipath](#)..... 148

8.7.1 Environment model and configuration

Access:

- ▶ Select "GNSS" > "Simulation Configuration" > "Receiver".

Environment Model

Selects the environment model.

"Line of Sight (LOS)"

The environmental model of an ideal environment with no environmental effects. The GNSS signal is a single signal that follows only the line of sight component of the signal.

"Vertical Obstacles"

The environmental model includes vertical obstacles, for example, for movement simulation in a city environment.

See [Chapter 8.7.2, "Vertical obstacles"](#), on page 134.

"Roadside Planes"

The environmental model includes planes, for example, for movement simulation on a road surrounded by buildings.

See [Chapter 8.7.3, "Roadside planes"](#), on page 138.

"Full Obscuration"

The environmental model includes full obscuration, for example, for movement simulation in tunnels.

See [Chapter 8.7.4, "Full obscuration"](#), on page 143.

"Ground/Sea Reflection"

The environmental model includes reflection elements, for example, for movement simulation with ground and sea reflections.

See [Chapter 8.7.5, "Ground/sea reflection"](#), on page 146.

"Static Multipath"

The environmental model includes multipath propagation of the GNSS signal.

See [Chapter 8.7.6, "Static multipath"](#), on page 148.

Remote command:

```
[ :SOURce<hw> ] :BB:GNSS:RECeiver [ :V<st> ] :ENVIRONMENT [ :MODEl ]  
on page 418
```

Environment Configuration

Accesses the "Environment Configuration" dialog to configure settings of the selected environmental model.

See ["Environment Model"](#) on page 133.

8.7.2 Vertical obstacles

Access:

1. Select "GNSS" > "GNSS Configuration" > "Receiver".
2. Select "Environment Model" > "Vertical Obstacles".
3. Select "Environment Configuration".

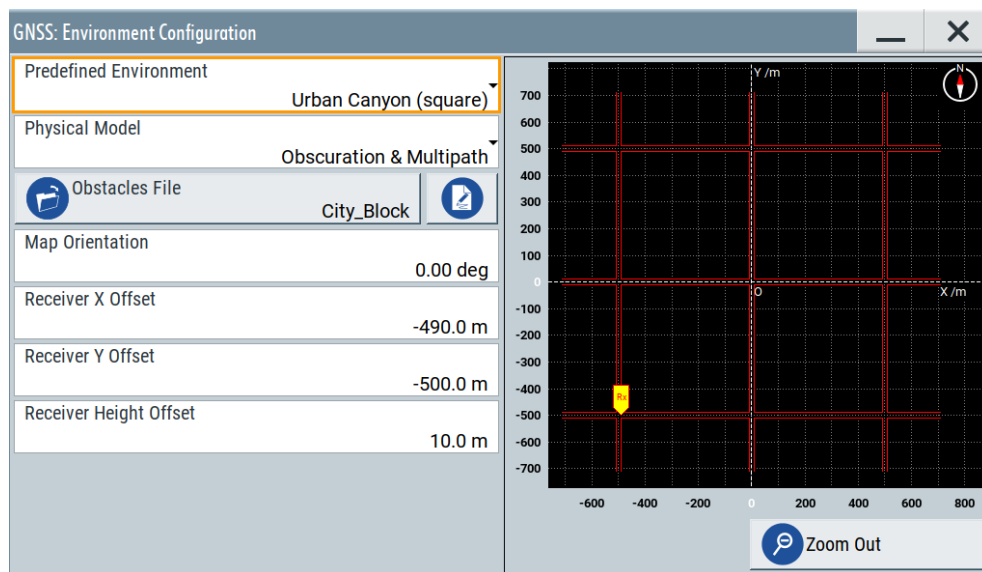

The vertical obstacles model is suitable for the simulation of obscurations and multipath effects expected in a city environment. Vertical obstacles are defined in a coordinate system and are either parallel to the x-axis or parallel to the y-axis following axis direction.

Settings:

Predefined Environment.....	135
Physical Model.....	135
Obstacles File.....	135
Edit Obstacles File.....	135
L Obstacles configuration table.....	136
L Material Property.....	136
L Direction.....	136
L 1st Edge X-Coord (m)/1st Edge Y-Coord (m).....	136
L Length (m)/Height (m).....	136
L Material.....	136
L Permittivity/Power Loss.....	137
L Insert, Delete, Save, Save as.....	137
Map Orientation.....	137
Receiver Offset.....	137
Graphic.....	138

Predefined Environment

Loads a predefined environment configuration.

You can load a user-defined setting or predefined settings that simulate two urban canyon environments.

Parameter	"Urban Canyon (square)"	"Urban Canyon (long)"
"Physical Model"	"Obscuration & Multipath"	"Obscuration & Multipath"
"Obstacles File"	City_Block.rs_obst	Urban_Canyon_1.rs_obst
"Map Orientation"	"0.00 deg"	"0.00 deg"
"Receiver X Offset"	"-490.0 m"	"15.0 m"
"Receiver Y Offset"	"-500.0 m"	"0.0 m"
"Receiver Height Offset"	"10.0 m"	"2.0 m"

Remote command:

[\[:SOURCE<hw>\]:BB:GNSS:RECEIVER\[:V<st>\]:ENVIRONMENT:VOBS:PREDEFINED](#) on page 406

Physical Model

Enables the simulation of environmental effects.

"Obscuration & Multipath"

Simulates obscuration effects and multipath propagation effects.

"Obscuration only"

Simulates only obscuration effects.

Remote command:

[\[:SOURCE<hw>\]:BB:GNSS:RECEIVER\[:V<st>\]:ENVIRONMENT:RPL:PMODEL](#) on page 404

[\[:SOURCE<hw>\]:BB:GNSS:RECEIVER\[:V<st>\]:ENVIRONMENT:VOBS:PMODEL](#) on page 404

[\[:SOURCE<hw>\]:BB:GNSS:RECEIVER\[:V<st>\]:ENVIRONMENT:PMODEL](#) on page 404

Obstacles File

Opens the standard "File Select" dialog to select predefined or user-defined obstacle description files (*.rs_obst).

Remote command:

[\[:SOURCE<hw>\]:BB:GNSS:OBSCURATION:VOBS:CATALOG:PREDEFINED?](#) on page 407

[\[:SOURCE<hw>\]:BB:GNSS:OBSCURATION:VOBS:CATALOG:USER?](#) on page 407

[\[:SOURCE<hw>\]:BB:GNSS:RECEIVER\[:V<st>\]:ENVIRONMENT:VOBS:FILE](#) on page 407

Edit Obstacles File

Opens a dialog to modify obstacles that are specified in the selected obstacles file. The dialog provides a table-based editor and a graphical representation of the obstacles configured in the table.

	Direction	1st Edge X-Coord (m)	1st Edge Y-Coord (m)	Length (m)	Height (m)	Material	Permittivity
1 >	OX	-710.0	510.0	200.0	20.0	User Def.	7.0
2	OX	-710.0	490.0	200.0	20.0	User Def.	7.0
3	OX	-710.0	10.0	200.0	20.0	User Def.	7.0
4	OX	-710.0	-510.0	200.0	20.0	User Def.	7.0
5	OX	-710.0	-490.0	200.0	20.0	User Def.	7.0
6	OX	-710.0	-10.0	200.0	20.0	User Def.	7.0
7	OY	-510.0	10.0	480.0	20.0	User Def.	7.0

Obstacles configuration table ← Edit Obstacles File

Provides settings to configure material and physical properties of obstacles. In the table, each row defines a vertical obstacle. The row index indicates the obstacle on the display view.

Material Property ← Obstacles configuration table ← Edit Obstacles File

Specifies, if the material is defined by its permittivity/conductivity or by its power loss characteristic.

Direction ← Obstacles configuration table ← Edit Obstacles File

Determines the alignment of the vertical obstacle.

"|| OX" Alignment is parallel to the x-axis.

"|| OY" Alignment is parallel to the y-axis.

1st Edge X-Coord (m)/1st Edge Y-Coord (m) ← Obstacles configuration table ← Edit Obstacles File

For vertical obstacles, sets the x-coordinate and y-coordinate of the start point (first edge) of the obstacle in meters. The first edge has the lowest coordinate value on its direction axis.

Length (m)/Height (m) ← Obstacles configuration table ← Edit Obstacles File

Defines the length and height of the obstacles in meters. The obstacle is parallel to the selected "Direction".

Material ← Obstacles configuration table ← Edit Obstacles File

Requires "Material Property > Permittivity".

Defines the material of the obstacle.

"User Def." User-defined material to configure the "Permittivity" manually.

"Glass/Concrete/Wood/Gypsum/Formica/Marble/Dry Wall/Brick"
Materials with fixed "Permittivity".

Permittivity/Power Loss ← Obstacles configuration table ← Edit Obstacles File

Sets the material property, permittivity or power loss, for the selected material. This value is a measure for the reflection caused by the obstacle.

Insert, Delete, Save, Save as ← Edit Obstacles File

Standard functions for adding/appending and removing table rows and saving changes.

Map Orientation

The map is aligned to the points of a compass. The map orientation represents the angle between the west-east direction and the X-axis. The compass sign indicates the direction to the north.

Example:

A map orientation of 0° means that the x-axis points to the east direction and the y-axis points to the north direction. A value of 90° means that the x-axis points to the north direction and the y-axis points to the west direction.

Remote command:

```
[ :SOURce<hw> ] :BB:GNSS:RECeiver [ :V<st> ] :ENVIRONMENT:VOBS:
MORIENTATION on page 406
```

Receiver Offset

Sets the initial position of a GNSS receiver relative to the reference point that is the (0, 0, 0) coordinate. The reference point is the reference for the definition of the vertical obstacles.

For a static receiver, configure the receiver offset. For a moving receiver, configure the start receiver offset.

Tip: Use these three offset parameters to set the start position of the receiver relative to the configured obstacles geometry without changing the obstacles definition in the table.

Note: Simulating moving receivers. For moving receivers, the position describes a vehicle geometric reference. The offset between an antenna and this reference is described in the antenna pattern (*.ant_pat).

The simulated GNSS signal refers to the antenna and not the vehicle geometric reference.

"Receiver X Offset"/"Start Rec. X Offset"

X offset of the first simulated receiver position in the (OX, OY) coordinate system.

Remote command:

```
[ :SOURce<hw> ] :BB:GNSS:RECeiver [ :V<st> ] :ENVIRONMENT:
VOBS:ROFFset:X on page 405
```

"Receiver Y Offset"/"Start Rec. Y Offset"

Y offset of the first simulated receiver position in the (OX, OY) coordinate system

Remote command:

```
[ :SOURCE<hw> ] :BB:GNSS:RECEIVER[:V<st>]:ENVIRONMENT:VOBS:ROFFSET:HEIGHT on page 405
```

"Receiver Height Offset"/"Start Rec. Height Offset"

Height offset of the first simulated receiver position in the (OX, OY) coordinate system

Remote command:

```
[ :SOURCE<hw> ] :BB:GNSS:RECEIVER[:V<st>]:ENVIRONMENT:VOBS:ROFFSET:HEIGHT on page 405
```

Graphic

Displays the position of the receiver and obstacles in a two coordinate system ("X (m)", "Y (m)"). For moving receivers, also display the trajectory and current position of the moving receiver.

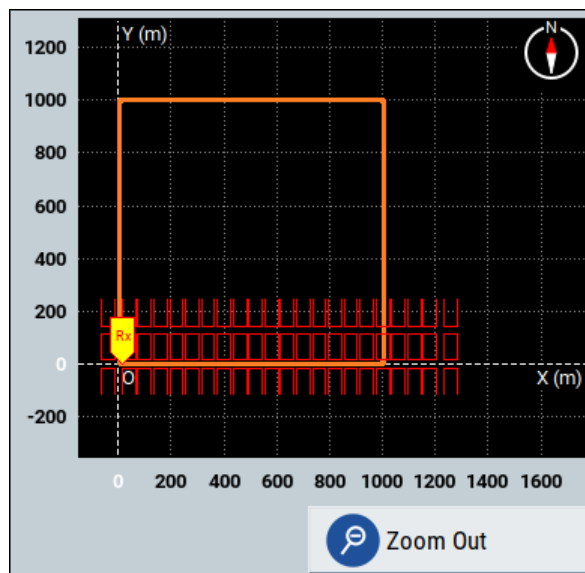

Figure 8-7: Obstacles file graphic: Obstacle position, receiver position (Rx) and trajectory

8.7.3 Roadside planes

Access:

1. Select "GNSS" > "GNSS Configuration" > "Receiver".
2. Select "Position" > "Moving".
3. Select "Environment Model" > "Roadside Planes".

4. Select "Environment Configuration".

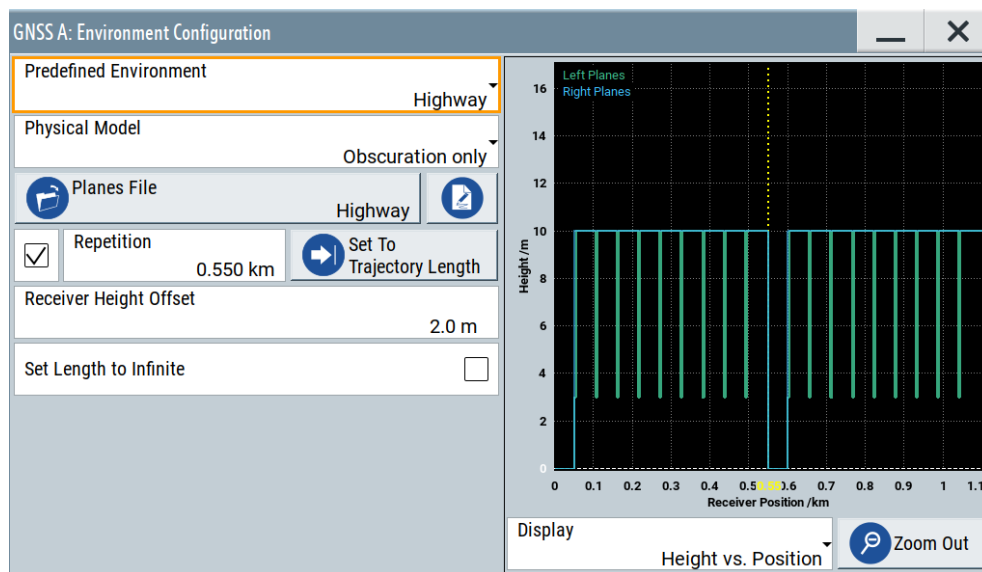

The roadside planes model is suitable for the simulation of effects that a moving receiver experiences while moving on a road surrounded, e.g., by buildings. The vertical roadside planes are defined alongside the road and parallel to the motion direction of the moving receiver. You can configure two vertical planes (left and right).

Settings:

- Predefined Environment..... 139
- Physical Model..... 140
- Planes File..... 140
- Planes File Edit..... 140
 - ↳ Roadside plane configuration table..... 141
 - ↳ Material Property..... 141
 - ↳ Alignment..... 141
 - ↳ Ref. Receiver Position (km)..... 141
 - ↳ Distance (m)..... 141
 - ↳ Height (m)..... 141
 - ↳ Material..... 141
 - ↳ Permittivity/Power Loss..... 142
 - ↳ Graphic..... 142
 - ↳ Insert, Delete, Save, Save as..... 142
- Repetition State..... 142
- Repetition..... 142
- Set To Trajectory Length..... 142
- Receiver Height Offset..... 143
- Set Length to Infinite..... 143

Predefined Environment

Loads a predefined environment configuration.

You can load a user-defined setting or predefined settings that simulate a highway, a suburban area or cutting environments.

Parameter	"Highway"	"Suburban Area"	"Cutting"
"Physical Model"	"Obscuration only"	"Obscuration & Multipath"	"Obscuration only"
"Planes File"	Highway.rs_buil	Suburban_1.rs_buil	Cutting.rs_buil
"Repetition"	"On"	"On"	"Off"
"Repetition Window"	"0.550 km"	"0.600 km"	"10.000 km"
"Receiver Height Offset"	"2.0 m"	"2.0 m"	"2.0 m"
"Set Length to Infinite"	"Off"	"Off"	"On"

Remote command:

```
[ :SOURCE<hw> ] :BB:GNSS:RECEIVER [ :V<st> ] :ENVIRONMENT:VOBS:
PREDEFINED on page 406
```

Physical Model

Enables the simulation of environmental effects.

"Obscuration & Multipath"

Simulates obscuration effects and multipath propagation effects.

"Obscuration only"

Simulates only obscuration effects.

Remote command:

```
[ :SOURCE<hw> ] :BB:GNSS:RECEIVER [ :V<st> ] :ENVIRONMENT:RPL:PMODEL
on page 404
[ :SOURCE<hw> ] :BB:GNSS:RECEIVER [ :V<st> ] :ENVIRONMENT:VOBS:PMODEL
on page 404
[ :SOURCE<hw> ] :BB:GNSS:RECEIVER [ :V<st> ] :ENVIRONMENT:PMODEL
on page 404
```

Planes File

Opens the standard "File Select" dialog to select a user-defined obstacle description file (*.rs_buil).

Remote command:

```
[ :SOURCE<hw> ] :BB:GNSS:OBSCURATION:RPL:CATALOG:PREDEFINED?
on page 407
[ :SOURCE<hw> ] :BB:GNSS:OBSCURATION:RPL:CATALOG:USER? on page 407
[ :SOURCE<hw> ] :BB:GNSS:RECEIVER [ :V<st> ] :ENVIRONMENT:RPL:FILE
on page 407
```

Planes File Edit

Opens a dialog to modify roadside planes that are specified in the selected planes file. The dialog provides a table-based editor and a graphical representation of the planes configured in the table.

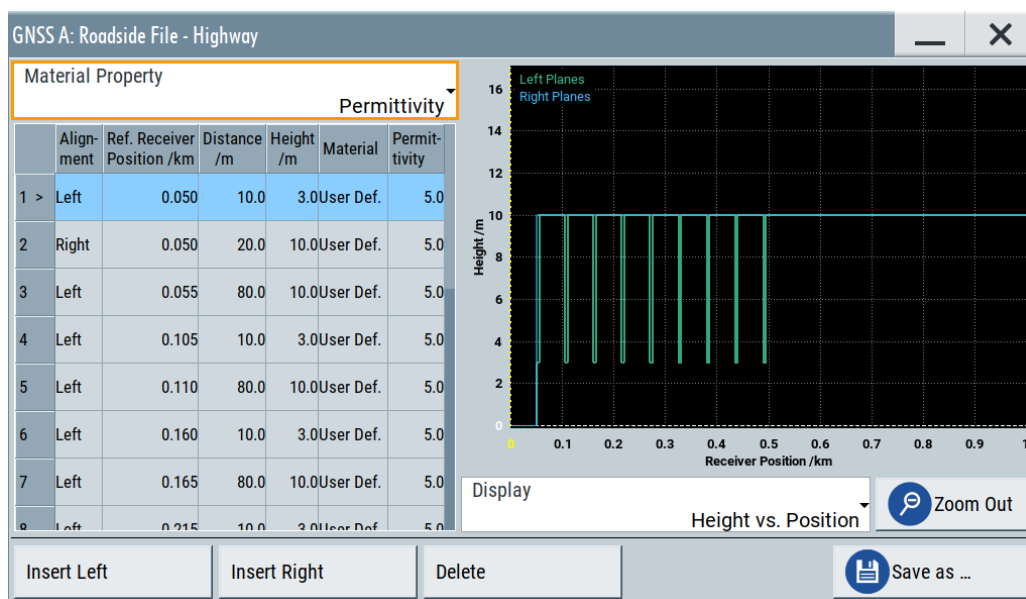

Roadside plane configuration table ← Planes File Edit

Provides settings to configure material and physical properties of obstacles. In the table, each row defines a roadside plane. The row index indicates the plane on the display view. Left and right planes are color-coded.

Material Property ← Roadside plane configuration table ← Planes File Edit

Specifies, if the material is defined by its permittivity/conductivity or by its power loss characteristic.

Alignment ← Roadside plane configuration table ← Planes File Edit

Aligns the obstacle location relative to the axis of moving (left or right).

Ref. Receiver Position (km) ← Roadside plane configuration table ← Planes File Edit

Sets the position of the roadside plane relative to the receiver position.

Distance (m) ← Roadside plane configuration table ← Planes File Edit

Sets the distance of the vertical obstacle to the OX or OY axis. The distance is expressed in meters.

Height (m) ← Roadside plane configuration table ← Planes File Edit

Sets the height of the obstacles in meters.

Material ← Roadside plane configuration table ← Planes File Edit

Requires "Material Property > Permittivity".

Defines the material of the obstacle.

"User Def." User-defined material to configure the "Permittivity" manually.

"Glass/Concrete/Wood/Gypsum/Formica/Marble/Dry Wall/Brick"
Materials with fixed "Permittivity".

Permittivity/Power Loss ← Roadside plane configuration table ← Planes File Edit

Sets the material property, permittivity or power loss, for the selected material. This value is a measure for the reflection caused by the obstacle.

Graphic ← Roadside plane configuration table ← Planes File Edit

Changes the display type of the configured roadside planes.

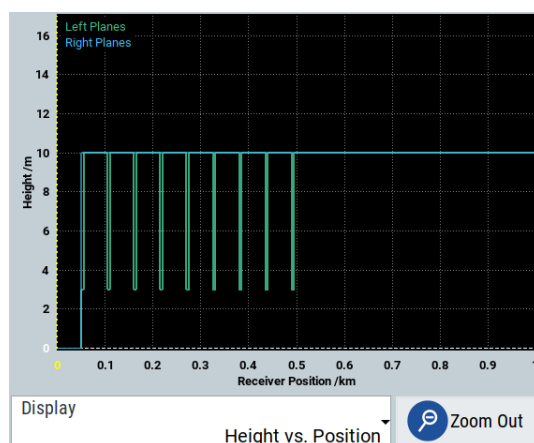

Figure 8-8: Height vs. Position representation of a highway model

Insert, Delete, Save, Save as ← Planes File Edit

Standard functions for adding/appending and removing table rows and saving changes.

Repetition State

Enables the repetition of obscured areas with the set repetition window.

Remote command:

```
[ :SOURCE<hw> ] :BB:GNSS:RECEIVER [ :V<st> ] :ENVIRONMENT:RPL:RWINDOW:STATE on page 408
```

Repetition

Sets the repetition window in kilometers. This window defines the distance of repeated obstacles that means contiguous objects.

Remote command:

```
[ :SOURCE<hw> ] :BB:GNSS:RECEIVER [ :V<st> ] :ENVIRONMENT:RPL:RWINDOW on page 408
```

Set To Trajectory Length

Sets the length of the repetition window equal to the trajectory length of the waypoint file.

Aligning both lengths is useful to ensure that the obscuration pattern repeats itself at each repetition of the waypoint file. See "[Trajectory Length/Duration](#)" on page 63.

Remote command:

```
[ :SOURCE<hw> ] :BB:GNSS:RECEIVER [ :V<st> ] :ENVIRONMENT:RPL:RWINDOW:STRAJECTORY on page 409
```

Receiver Height Offset

Sets the initial height offset or Z position of a GNSS receiver relative to the reference point that is the (0, 0, 0) coordinate. The reference point is the reference for the definition of the roadside planes.

Tip: Use this offset parameter to set the start position of the receiver relative to the configured roadside planes geometry without changing the obstacles definition in the table.

Remote command:

```
[ :SOURCE<hw> ] :BB:GNSS:RECEIVER[:V<st>]:ENVIRONMENT:RPL:ROFFSET:HEIGHT on page 408
```

Set Length to Infinite

If enabled, assumes planes with infinite width.

Enable this parameter to simulate a cutting scenario.

Remote command:

```
[ :SOURCE<hw> ] :BB:GNSS:RECEIVER[:V<st>]:ENVIRONMENT:RPL:ILENGTH on page 409
```

8.7.4 Full obscuration

Access:

1. Select "GNSS > Simulation Configuration > Receiver".
2. Select "Environment Model > Full Obscuration".
3. Select "Environment Configuration".

Obscured Areas:	
Reference /km	Length /km
1 >	0.000 24.500
2	

The full obscuration model is suitable to simulate areas in that the satellite signal is fully obscured, like in tunnels.

Predefined Environment..... 144
 Reference Scale..... 145
 Repetition Window..... 145
 L State..... 145
 L Repetition..... 145
 Set To Trajectory Length..... 145
 Obscured Areas..... 145
 L Insert, Delete..... 146

Predefined Environment

Loads a predefined environment configuration.

You can load a user-defined setting or predefined settings that simulate a long tunnel, multiple bridges or parking environments. The tables below provide an overview of the configuration of the predefined obscured environments.

Table 8-2: Predefined environment configuration with Reference Scale > Distance /km

"Predefined Environment"	"Repetition State", "Window"	Obscured areas: "Reference /km", "Length /km"
"Long Tunnel"	"Off", "10.000 km"	"0.000", "24.500"
"Multiple Tunnels"	"Off", "10.000 km"	"0.000", "0.240" "0.700", "0.400" "2.000", "0.100" "2.500", "0.300" "3.500", "0.100" "5.000", "0.200" "7.000", "0.400" "9.400", "0.200"
"Multiple Bridges (each 50 m)"	"On", "1.000 km"	"0.250", "0.050" "0.750", "0.050"

Table 8-3: Predefined environment configuration with Reference Scale > Time /s

"Predefined Environment"	"Repetition State", "Window"	Obscured areas: "Reference /s", "Duration /s"
"Multiple Bridges (each 30 s)"	"Off", "10.0 s"	"30.0", "30.0" (13 additional obscured areas with distance of 60.0 s for contiguous reference points) "870.0", "30.0"
"Parking (1 min)"	"On", "300.0 s"	"120.0", "60.0"
"Parking (10 min)"	"On", "840.0 s"	"120.0", "600.0"
"Parking (1 hour)"	"On", "3840.0 s"	"120.0", "3600.0"

Remote command:

```
[ :SOURCE<hw> ] :BB:GNSS:RECEIVER [ :V<st> ] :ENVIRONMENT:FULL:PREDEFINED on page 406
```

Reference Scale

Defines whether the obstacles' positions are defined as distance (in km) or as time (in s).

Note: Changing between the two scales without saving the configuration leads to data loss.

Remote command:

`[:SOURCE<hw>] :BB:GNSS:RECEIVER [:V<st>] :ENVIRONMENT:FULL:SCALE`
on page 409

Repetition Window

Comprises the settings for defining a repetition window including activation and setting the repetition interval.

State ← Repetition Window

Activates the repetition window of the obscured area with the set repetition interval.

Remote command:

`[:SOURCE<hw>] :BB:GNSS:RECEIVER [:V<st>] :ENVIRONMENT:FULL:RWINDOW:STATE`
on page 410

Repetition ← Repetition Window

Sets the repetition interval in kilometers or seconds depending on the set "Reference Scale".

Remote command:

`[:SOURCE<hw>] :BB:GNSS:RECEIVER [:V<st>] :ENVIRONMENT:FULL:RWINDOW`
on page 410

Set To Trajectory Length

Requires receiver "Position > Moving".

Sets the length of the repetition interval equal to trajectory length of the waypoint file.

Aligning both lengths is useful to ensure that the obscuration pattern repeats itself at each repetition of the waypoint file. See "[Trajectory Length/Duration](#)" on page 63.

Remote command:

`[:SOURCE<hw>] :BB:GNSS:RECEIVER [:V<st>] :ENVIRONMENT:FULL:RWINDOW:STRAJECTORY`
on page 410

Obscured Areas

Defines fully obscured areas.

An obscured area has a defined reference position and a defined length or duration. Each zone is defined in one table row.

Tips:

- To simulate repetition of obscured areas, define the obscured areas and the repetition interval.
Activate the repetition window.
- To zoom into an obscured area on the graphical display, drag a rectangular.
- To visualize all configured full obscuration areas, select "Zoom Out".

Area count	Displays the number of the obscured area. Remote command: <code>[:SOURCE<hw>] :BB:GNSS:RECEIVER[:V<st>]:ENVIRONMENT:FULL:AREA:COUNT?</code> on page 410
"Reference"	Defines the reference starting position or timestamp at which a specific obscured zone is applied. Remote command: <code>[:SOURCE<hw>] :BB:GNSS:RECEIVER[:V<st>]:ENVIRONMENT:FULL:AREA<ch>:REFERENCE</code> on page 411
"Length/Duration"	Length or duration of the obscured zone defined in kilometers or seconds. Remote command: <code>[:SOURCE<hw>] :BB:GNSS:RECEIVER[:V<st>]:ENVIRONMENT:FULL:AREA<ch>:LENGTH</code> on page 411

Insert, Delete ← Obscured Areas

Standard functions for inserting and removing table rows and saving changes.

Remote command:

`[:SOURCE<hw>] :BB:GNSS:RECEIVER[:V<st>]:ENVIRONMENT:FULL:AREA:APPEND` on page 411

`[:SOURCE<hw>] :BB:GNSS:RECEIVER[:V<st>]:ENVIRONMENT:FULL:AREA<ch>:INSERT` on page 411

`[:SOURCE<hw>] :BB:GNSS:RECEIVER[:V<st>]:ENVIRONMENT:FULL:AREA<ch>:DELETE` on page 411

8.7.5 Ground/sea reflection

Access:

1. Select "GNSS > Simulation Configuration > Receiver".
2. Select "Environment Model > Ground/Sea Reflection".

3. Select "Environment Configuration".

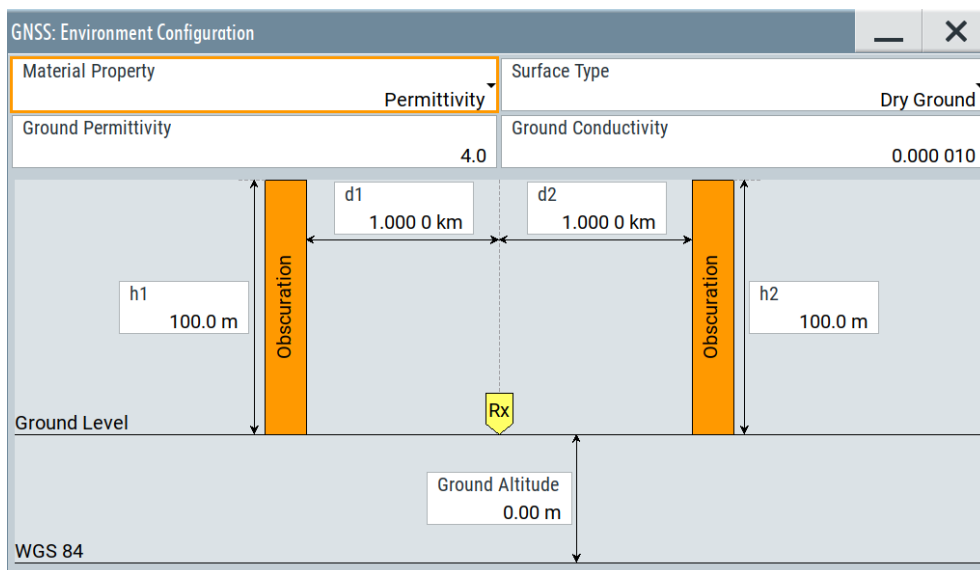

This model is suitable for the simulation of obscurations and multipath effects caused by ground and sea reflections. The model is available for ship, aircraft and spacecraft vehicles and describes canyon vertical obstacles parallel to the motion direction of the vehicle (direction axis).

Material Property..... 147
 Surface Type..... 147
 Ground Permittivity/Conductivity, Power Loss..... 148
 h1/h2, d1/d2..... 148
 Ground Altitude..... 148

Material Property

Define whether the material is defined by its permittivity/conductivity or power loss characteristic.

The material properties depend on the selected surface type.

Remote command:

```
[ :SOURCE<hw> ] :BB:GNSS:RECEIVER[ :V<st> ] :ENVIRONMENT:GSR:MPROPERTY
```

on page 412

Surface Type

Describes the surface.

Available are "Dry Ground", "Medium Dry Ground", "Wet Ground", "Fresh Water" and "Sea Water". The different surfaces feature different reflection characteristics.

Remote command:

```
[ :SOURCE<hw> ] :BB:GNSS:RECEIVER[ :V<st> ] :ENVIRONMENT:GSR:STYPE
```

on page 412

Ground Permittivity/Conductivity, Power Loss

Displays/defines the surface property, permittivity, conductivity or power loss, for the selected surface type. This value is a measure for the reflection caused by the surface.

Remote command:

`[:SOURCE<hw>] :BB:GNSS:RECEIVER[:V<st>] :ENVIRONMENT:GSR:PERMITTIVITY` on page 412

`[:SOURCE<hw>] :BB:GNSS:RECEIVER[:V<st>] :ENVIRONMENT:GSR:CONDUCTIVITY` on page 413

`[:SOURCE<hw>] :BB:GNSS:RECEIVER[:V<st>] :ENVIRONMENT:GSR:PLOSS` on page 413

h1/h2, d1/d2

Sets the height of the right/left obstacle and the distance between the receiver and the obstacles.

Remote command:

`[:SOURCE<hw>] :BB:GNSS:RECEIVER[:V<st>] :ENVIRONMENT:GSR:O1DISTANCE` on page 413

`[:SOURCE<hw>] :BB:GNSS:RECEIVER[:V<st>] :ENVIRONMENT:GSR:O2DISTANCE` on page 413

`[:SOURCE<hw>] :BB:GNSS:RECEIVER[:V<st>] :ENVIRONMENT:GSR:O1HEIGHT` on page 414

`[:SOURCE<hw>] :BB:GNSS:RECEIVER[:V<st>] :ENVIRONMENT:GSR:O2HEIGHT` on page 414

Ground Altitude

Sets the altitude of the ground level relative to the WGS84 ellipsoid, i.e. the terrain ground level is set relative to WGS84 zero level or sea level.

Remote command:

`[:SOURCE<hw>] :BB:GNSS:RECEIVER[:V<st>] :ENVIRONMENT:GSR:GALTTITUDE` on page 414

8.7.6 Static multipath

Access:

1. Select "GNSS > Simulation Configuration > Receiver".
2. Select "Environment Model > Static Multipath".
3. Select "Environment Configuration".

With the provided parameters, you can simulate signals undergoing multipath propagation.

You can configure the number of echoes and the individual time and Doppler shifts, power and carrier phase of each of them. A graph displays the resulting propagation.

In advanced mode with several antennas, the dialog comprises of several tabs. There is one per antenna so that you can define individual multipath conditions for each of the antennas.

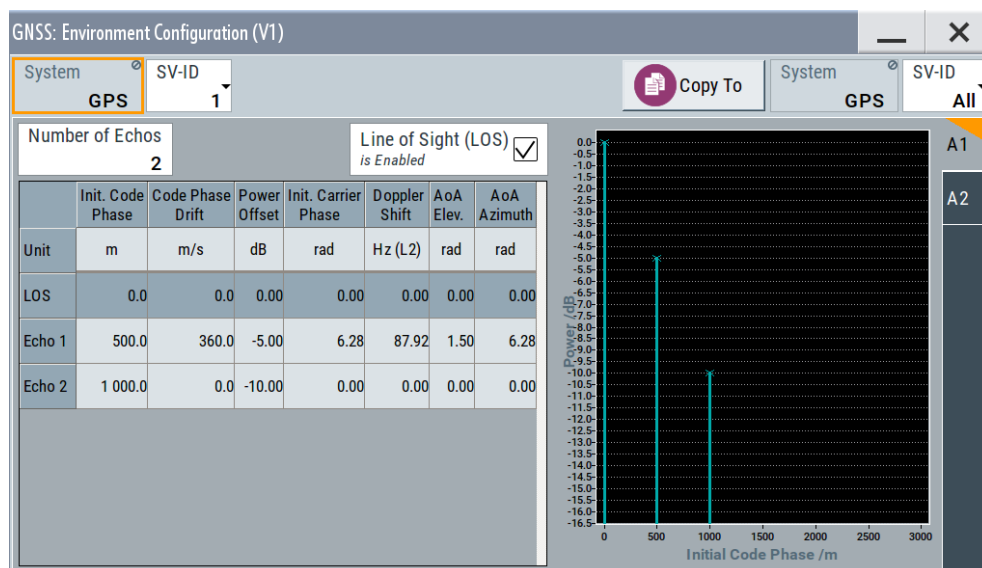

Settings:

Standard, SV-ID (source), Copy To, Standard, SV-ID (target)..... 149

Number of Echos..... 150

Line of Sight (LOS)..... 150

LOS and Echoes Table..... 150

- L Unit..... 150
- L Init. Code Phase..... 150
- L Code Phase Drift..... 150
- L Power Offset..... 151
- L Init. Carrier Phase..... 151
- L Doppler Shift /Hz..... 151
- L AoA Elevation, AoA Azimuth..... 151

Standard, SV-ID (source), Copy To, Standard, SV-ID (target)

Defines the GNSS standard and the SV ID for that the multipath is configured.

To use the same configuration for another SV ID or all other SV IDs, define the SV ID as "Standard, SV-ID" (target) and select "Copy To".

Remote command:

`[:SOURce<hw>] :BB:GNSS:RECeiver [:V<st>] :ENVironment:MPATH:SYSTEM`
on page 419

`[:SOURce<hw>] :BB:GNSS:RECeiver [:V<st>] :ENVironment:MPATH:SVID`
on page 419

`[:SOURce<hw>] :BB:GNSS:RECeiver [:V<st>] :ENVironment:MPATH:COPY:SYSTEM`
on page 420

`[:SOURCE<hw>] :BB:GNSS:RECEIVER [:V<st>] :ENVIRONMENT:MPATH:COPY:SVID` on page 420

`[:SOURCE<hw>] :BB:GNSS:RECEIVER [:V<st>] :ENVIRONMENT:MPATH:COPY:EXECUTE` on page 421

Number of Echos

Sets the echoes number. The value determines the number of rows available for configuration.

Remote command:

`[:SOURCE<hw>] :BB:GNSS:SVID<ch>:GPS:MPATH [:V<us>:A<gr>] :ECHOS:COUNT` on page 422

(etc. for the other GNSS systems)

Line of Sight (LOS)

Defines if a LOS component is present or not.

Remote command:

`[:SOURCE<hw>] :BB:GNSS:SVID<ch>:GPS:MPATH [:V<us>:A<gr>] :LOS:ENABLE` on page 421

(etc. for the other GNSS systems)

LOS and Echoes Table

Configuration of the LOS signal and the echoes, one row per multipath tap, where:

- LOS is present if "Line of Sight (LOS) > On"
- Number of echoes is defined by the parameter "Number of Echos"

Unit ← LOS and Echoes Table

You can change the units of the parameters. The affected values are automatically recalculated.

Note: The selected units are used only in the manual control (display). In remote control, SCPI commands always use the default units.

Init. Code Phase ← LOS and Echoes Table

Sets an initial code phase (or delay) for the selected echo. To simulated echo delay variation with the time, set the parameters [Code Phase Drift](#) and [Doppler Shift /Hz](#).

The severity of the multipath effect depends on the delay of the echoes and their power.

Remote command:

`[:SOURCE<hw>] :BB:GNSS:SVID<ch>:GPS:MPATH [:V<us>:A<gr>] :ECHO<s2us0>:ICPHASE` on page 423

(etc. for the other GNSS systems)

Code Phase Drift ← LOS and Echoes Table

Sets a code phase drift that influences the delay of the echoes.

"Code Phase Drift" and "Doppler Shift" are interdependent. Changing either of them affects the value of the other.

Remote command:

```
[ :SOURce<hw> ] :BB:GNSS:SVID<ch>:GPS:MPATH[:V<us>:A<gr>]:  
ECHO<s2us0>:CPDRift on page 423  
(etc. for the other GNSS systems)
```

Power Offset ← LOS and Echoes Table

Sets the additional power offset for the echo.

Remote command:

```
[ :SOURce<hw> ] :BB:GNSS:SVID<ch>:GPS:MPATH[:V<us>:A<gr>]:  
ECHO<s2us0>:POWER on page 424  
(etc. for the other GNSS systems)
```

Init. Carrier Phase ← LOS and Echoes Table

Sets the carrier phase at the simulation start.

Remote command:

```
[ :SOURce<hw> ] :BB:GNSS:SVID<ch>:GPS:MPATH[:V<us>:A<gr>]:  
ECHO<s2us0>:CPHase on page 425  
(etc. for the other GNSS systems)
```

Doppler Shift /Hz ← LOS and Echoes Table

Enters the additional Doppler shift that influences the delay of the echoes.

"Code Phase Drift" and "Doppler Shift" are interdependent. Changing either of them affects the value of the other.

Remote command:

```
[ :SOURce<hw> ] :BB:GNSS:SVID<ch>:GPS:MPATH[:V<us>:A<gr>]:  
ECHO<s2us0>:DSHift on page 426  
(etc. for the other GNSS systems)
```

AoA Elevation, AoA Azimuth ← LOS and Echoes Table

Sets the angle of arrival parameters elevation and azimuth.

These parameters are considered if non-isotropic antenna patterns are used.

Remote command:

```
[ :SOURce<hw> ] :BB:GNSS:SVID<ch>:GPS:MPATH[:V<us>:A<gr>]:  
ECHO<s2us0>:AELEVation on page 427  
[ :SOURce<hw> ] :BB:GNSS:SVID<ch>:GPS:MPATH[:V<us>:A<gr>]:  
ECHO<s2us0>:AAZimuth on page 427  
(etc. for the other GNSS systems)
```

9 Real-time kinematics

Key features

The option R&S SMW-K122 real-time kinematics (RTK) virtual reference station features:

- Simulation of one RTK virtual reference station
- Static position of the RTK virtual reference station including one antenna
- RTK data transfer over LAN interface via NTRIP (Networked Transport of RTCM via Internet Protocol)
- Simulation modes:
 - GNSS standard mode: RTK simulation for baseband path A only
 - GNSS advanced mode: Up to 408 GNSS channels

GNSS positioning with RTK

The real-time kinematics (RTK) positioning system consists of at least of three components: A GNSS reference receiver or reference station, a satellite and a GNSS rover that is the device under test (DUT). [Figure 9-1](#) illustrates such an RTK system to determine the position R_{rov} of the GNSS rover.

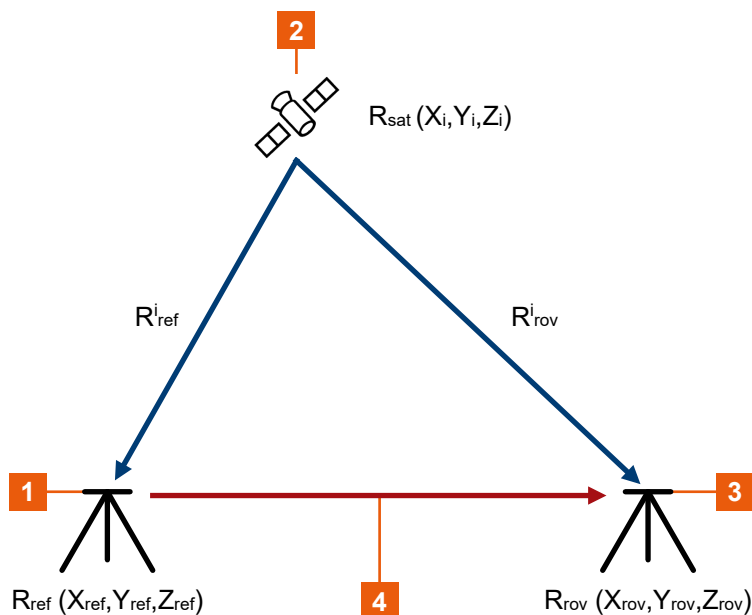

Figure 9-1: RTK principle

- 1 = GNSS reference station (base station) with coordinates R_{ref}
- 2 = Satellite with coordinates R_{sat}
- 3 = GNSS rover (DUT) with coordinates R_{rov}
- 4 = Baseline vector $R_{base} = [R_{rov} - R_{ref}]$
- R_{ref}^i = Distance between GNSS reference station and satellite
- R_{rov}^i = Distance between GNSS rover and satellite

The GNSS reference station has a known location R_{ref} , the trajectory of the satellite R_{sat} is also known. Measurements for the distance between satellite and GNSS reference station R_{ref}^i and satellite and GNSS rover R_{rov}^i are available. From these measurements, you can compute the baseline vector R_{base} that is the distance between GNSS rover and GNSS reference station. Using the baseline vector R_{base} and the position of the GNSS reference station R_{ref} you can compute the position of the GNSS rover R_{rov} . Equation 9-1 provides an overview.

$$R_{rov} = R_{ref} + R_{base} \quad | \quad R_{base} = R_{rov}^i - R_{ref}^i$$

$$R_{rov}^i = R_{rov} - R_{sat} \quad | \quad R_{ref}^i = R_{ref} - R_{sat}$$

Equation 9-1: GNSS rover position

Note that this position determination has a limited accuracy. The following errors affect the position measurements:

- Satellite clock error
- Satellite orbit error
- Atmospheric delay
- Receiver clock error
- Noise and multipath propagation errors

The determination of the baseline vector $R_{base} = R_{rov} - R_{ref}$ uses single location differences. The technique eliminates the satellite clock error and reduces the satellite orbit error and the atmospheric delay influences. Further corrections require GNSS carrier phase corrections.

The RTK approach in this firmware is to provide pseudorange data and carrier range data via the RTCM protocol to compute the baseline vector more accurately.

- [Required options](#)..... 153
- [RTK configuration](#)..... 154
- [RTK protocol configuration](#)..... 156
- [RTK position configuration](#)..... 157
- [RTK antenna configuration](#)..... 160

9.1 Required options

The equipment for real-time kinematics simulation includes the R&S SMW200A equipped with the options as described in the table below.

Option	Designation
R&S SMW-B9	Wideband generator
R&S SMW-Kx ¹⁾	GNSS system option
R&S SMW-K122	RTK virtual reference station

¹⁾ K<x> denotes a GNSS system option: R&S SMW-K44/K66/K94/K97/K98/K107/K132
 See also [Chapter 2.1, "Required options"](#), on page 17.

9.2 RTK configuration

Access:

- ▶ Select "GNSS" > "RTK Configuration".

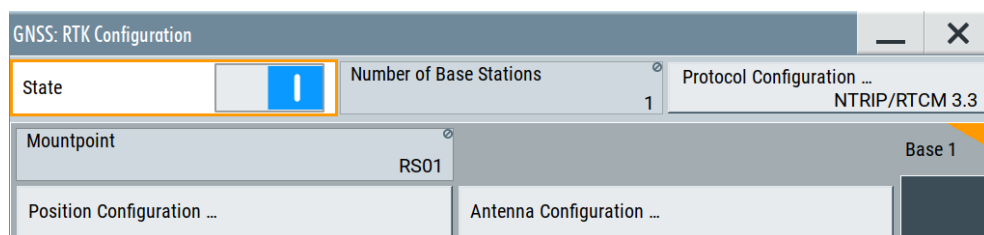

The dialog provides settings to configure simulation of a real-time kinematics (RTK) reference station (base station) at the R&S SMW200A. There are dedicated settings for activating RTK and configuring the RTK protocol. Also, you can configure t, position and environment of an RTK base station.

The remote commands required to define RTK settings are described in [Chapter 22.6, "Real-time kinematics \(RTK\) commands"](#), on page 393.

Settings:

State	154
Number of Base Stations	154
Protocol Configuration	155
Mountpoint	155
Position Configuration	155
Antenna Configuration	155

State

Activates real-time kinematics (RTK) simulation.

Remote command:

`[:SOURce<hw>] :BB:GNSS:RTK:STATe` on page 395

Number of Base Stations

Displays the number of RTK base stations.

You can configure one RTK base station. This base station has a dedicated configuration, that you can access via the "Base 1" side tab.

Remote command:

`[:SOURce<hw>] :BB:GNSS:RTK:BStation:COUNT` on page 395

Protocol Configuration

Accesses a dialog to configure the RTK protocol, see [Chapter 9.3, "RTK protocol configuration"](#), on page 156.

Also, it displays the used protocol that is "NTRIP/RTCM 3.3".

Mountpoint

Sets the mountpoint of the RTK base station for RTK simulation.

"RS0x" Mountpoint of the RTK base station "x", e.g. "RS01" for the first virtual reference station.

Remote command:

`[:SOURCE<hw>] :BB:GNSS:RTK:BASE<st>:MOUNTpoint?` on page 395

Position Configuration

Accesses the position configuration dialog. You can configure the position of a GNSS receiver or of an RTK base station.

The GNSS receiver position depends on the GNSS receiver type:

- [Chapter 5.2, "Static receiver"](#), on page 54
- [Chapter 5.3, "Moving receiver"](#), on page 59
- [Chapter 19.2, "HIL settings"](#), on page 321

To configure the position of the RTK base station, see [Chapter 9.4, "RTK position configuration"](#), on page 157.

Antenna Configuration

Accesses the antenna configuration dialog. You can configure antennas of a GNSS receiver or of an RTK base station.

To configure antennas of a GNSS receiver, see [Chapter 8.6, "Antenna and body mask settings"](#), on page 125.

To configure the antenna of an RTK base station, see [Chapter 9.5, "RTK antenna configuration"](#), on page 160.

9.3 RTK protocol configuration

Access:

- ▶ Select "GNSS" > "RTK Configuration" > "Protocol Configuration".

GNSS: RTK Protocol Configuration	
Protocol	NTRIP/RTCM 3.3
Host IP	10.102.52.41
Port	2101
User ID	instr1
Password	instr1

The dialog provides settings to configure the RTK protocol used for the output of RTK data at the "LAN" connector on the rear panel of the R&S SMW200A.

Settings:

Protocol.....	156
Host IP.....	156
Port.....	156
User ID.....	156
Password.....	157

Protocol

Displays the protocol "NTRIP/RTCM 3.3" used for transmitting RTK data.

RTK corrections are provided in RTCM 3 format via an integrated Ntrip server.

Remote command:

[\[:SOURce<hw>\]:BB:GNSS:RTK:PROTOCOL](#) on page 401

Host IP

Displays the IP address of the host that is the R&S SMW200A.

For more information, see chapter "Network Settings" in the R&S SMW200A user manual.

Port

Sets the port of the LAN connection.

You can use ports "2101", "4022" and "50000".

Remote command:

[\[:SOURce<hw>\]:BB:GNSS:RTK:PORT](#) on page 401

User ID

Displays the user ID that is the RTCM user name. The user ID is "instr1".

Remote command:

[:SOURce<hw>] :BB:GNSS:RTK:PROTocol on page 401

Password

Displays the password. The password is "instr1".

Remote command:

[:SOURce<hw>] :BB:GNSS:RTK:PASSword? on page 401

9.4 RTK position configuration

Access:

- ▶ Select "GNSS" > "RTK Configuration" > "Position Configuration".

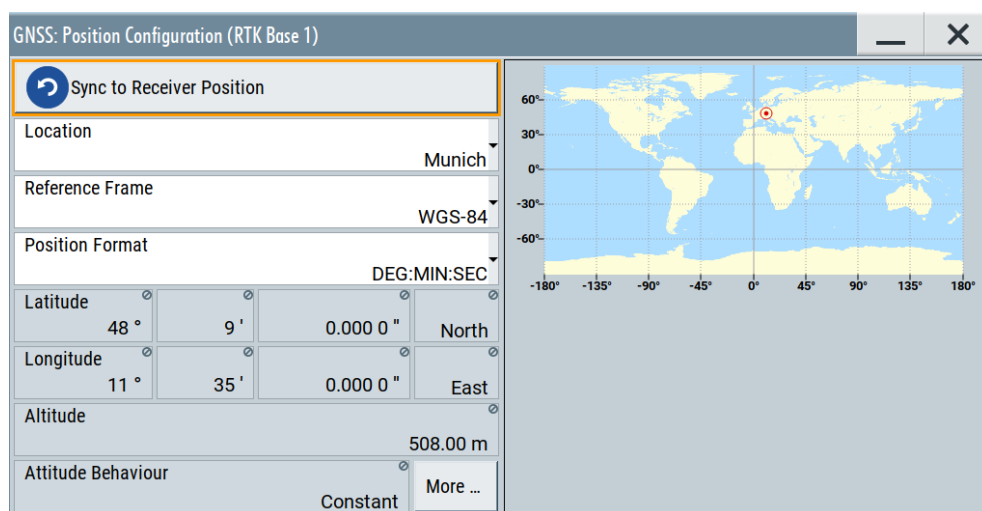

The dialog provides settings to configure the position of a real-time kinematics (RTK) base station.



Settings:

[Sync to Receiver Position](#)..... 157
[Location, Initial Position](#)..... 158
[Reference Frame](#)..... 159
[Location Coordinates, Position Format](#)..... 159

Sync to Receiver Position

Triggers position synchronization of the RTK base station with the current position of the GNSS receiver as defined in "[Location, Initial Position](#)" on page 55.

Use this setting, for example, to synchronize the RTK base station with the current position of a moving receiver. Synchronization fails, if the distance between RTK base station and the receiver is higher than 150 km. A warning message displays synchronization failure.

 (A)RTK Base 1 is far away (5310 km) from receiver, potentially receiver may not use it  Close

Remote command:

`[:SOURCE<hw>] :BB:GNSS:RTK:BASE<st>:LOCATION:SYNC` on page 399

Location, Initial Position

Selects the location or initial position depending on the simulated object:

- Static GNSS receiver ("Position > Static"): Selects the geographic location of the GNSS receiver.
- R&S SMW-K109: Hardware in the loop (HIL) GNSS receiver ("Position > From Remote"): Selects the initial position of the GNSS receiver.
- R&S SMW-K122: Real-time kinematics (RTK) base station: Selects the geographic location of the RTK base station.

The representation of the coordinates depends on the selected "Reference Frame" and "Position Format".

"User Defined" Sets the receiver position in terms of "Latitude", "Longitude" and "Altitude"

"City" Selects a predefined geographic location, see [Table 5-1](#) for an overview. The parameters "Latitude", "Longitude" and "Altitude" are set automatically.

Table 9-1: Coordinates of the simulated predefined positions

Continent	City	Latitude [deg]	Longitude [deg]	Altitude [m]
Europe	London	51.500625	-0.1246219	22
	Moscow	55.7522222	37.6155556	200
	Munich	48.15	11.5833333	508
	Paris	48.8584	2.2946278	66
America	New York	40.714667	-74.0063889	1
	San Francisco	37.8194389	-122.4784939	35
	Anchorage	61.2166667	-149.8833333	115
	Mexico City	19.4510539	-99.1255189	2310
	Bogota	4.7111111	-74.0722222	2640
	Sao Paulo	-23.5337731	-46.62529	760
	Santiago de Chile	-33.4474869	-70.6736758	522
Asia	Beijing	39.9055556	116.3913889	60
	New Delhi	28.6138889	77.2088889	77
	Seoul	37.5514997	126.9877939	265
	Singapore	1.3113108	103.8268528	110
	Taipei	25.0223439	121.5147581	10

Continent	City	Latitude [deg]	Longitude [deg]	Altitude [m]
	Tokyo	35.6838611	139.7450581	45
Africa	Cairo	30.0444419	31.2357117	23
	Dakar	14.7166769	-17.4676858	22
	Cape Town	-33.9188611	18.4233	6
Australia	Sydney	-33.8833333	151.2166667	3
	Perth	-31.9535119	115.8570481	2

Remote command:

`[:SOURce<hw>] :BB:GNSS:RECEiver [:V<st>] :LOCation:CATalog`

on page 382

`[:SOURce<hw>] :BB:GNSS:RECEiver [:V<st>] :LOCation[:SElect]`

on page 383

`[:SOURce<hw>] :BB:GNSS:RTK:BASE<st>:LOCation:CATalog` on page 396

`[:SOURce<hw>] :BB:GNSS:RTK:BASE<st>:LOCation[:SElect]` on page 396

Reference Frame

For GNSS receiver, selects the reference frame used to define the receiver coordinates. The transformation between the reference frames is performed automatically.

R&S SMW-K122: For RTK base station, selects the reference frame used to define the receiver or RTK base station coordinates. The transformation between the reference frames is performed automatically.

The following applies:

- $X_{WGS84} = (1 - 0.008 \cdot 10^{-6}) \cdot X_{PZ90} - 0.2041 \cdot 10^{-7} \cdot Y_{PZ90} + 0.1716 \cdot 10^{-7} \cdot Z_{PZ90} - 0.013$
- $Y_{WGS84} = (1 - 0.008 \cdot 10^{-6}) \cdot Y_{PZ90} - 0.2041 \cdot 10^{-7} \cdot X_{PZ90} + 0.1115 \cdot 10^{-7} \cdot Z_{PZ90} + 0.106$
- $Z_{WGS84} = (1 - 0.008 \cdot 10^{-6}) \cdot Z_{PZ90} - 0.1716 \cdot 10^{-7} \cdot X_{PZ90} - 0.1115 \cdot 10^{-7} \cdot Y_{PZ90} + 0.022$

Both reference frames are ECEF frames with a set of associated parameters.

"WGS-84" The World Geodetic System WGS-84 is the reference frame used by GPS.

"PZ 90.11 (GLONASS)"

Parametry Zemli PZ (Parameters of the Earth) is the reference frame used by GLONASS.

Remote command:

`[:SOURce<hw>] :BB:GNSS:RECEiver [:V<st>] :LOCation:COORDinates:`

`RFRame` on page 383

`[:SOURce<hw>] :BB:GNSS:RTK:BASE<st>:LOCation:COORDinates:RFRame`

on page 396

Location Coordinates, Position Format

In the ECEF coordinate system, a geographic location is identified by three coordinates, the altitude, latitude and longitude. The last two can be displayed in decimal or DMS format. The display format is determined by the parameter "Position Format".

Parameter	Description
"Position Format"	Sets the format in which the Latitude and Longitude are displayed. <ul style="list-style-type: none"> "DEG:MIN:SEC" The display format is Degree:Minute:Second and Direction, i.e. <code>XX°XX'XX.XX" Direction</code>, where direction can be North/South and East/West. "Decimal Degrees" The display format is decimal degrees, i.e. <code>+/-XX.XXXXXX°</code>, where "+" indicates North and East and "-" indicates South and West.
"Altitude"	Sets the altitude of the reference location. The altitude value is the height above the ellipsoid (HAE), that is the reference ellipsoid (WGS84 or PZ90).
"Latitude"	Sets the latitude of the reference location.
"Longitude"	Sets the longitude of the reference location.

Altitude, latitude and longitude are configurable, if "Location, Initial Position > User Defined".

Remote command:

`[:SOURCE<hw>] :BB:GNSS:RECEIVER[:V<st>]:LOCATION:COORDINATES:FORMAT` on page 383

`[:SOURCE<hw>] :BB:GNSS:RTK:BASE<st>:LOCATION:COORDINATES:FORMAT` on page 397

To enter the coordinates in "Position Format > DEG:MIN:SEC"

`[:SOURCE<hw>] :BB:GNSS:RECEIVER[:V<st>]:LOCATION:COORDINATES:DMS:PZ` on page 384

`[:SOURCE<hw>] :BB:GNSS:RECEIVER[:V<st>]:LOCATION:COORDINATES:DMS[:WGS]` on page 384

`[:SOURCE<hw>] :BB:GNSS:RTK:BASE<st>:LOCATION:COORDINATES:DMS:PZ` on page 398

`[:SOURCE<hw>] :BB:GNSS:RTK:BASE<st>:LOCATION:COORDINATES:DMS[:WGS]` on page 398

To enter the coordinates in "Position Format > Decimal Degrees"

`[:SOURCE<hw>] :BB:GNSS:RECEIVER[:V<st>]:LOCATION:COORDINATES:DECIMAL:PZ` on page 384

`[:SOURCE<hw>] :BB:GNSS:RECEIVER[:V<st>]:LOCATION:COORDINATES:DECIMAL[:WGS]` on page 384

`[:SOURCE<hw>] :BB:GNSS:RTK:BASE<st>:LOCATION:COORDINATES:DECIMAL:PZ` on page 397

`[:SOURCE<hw>] :BB:GNSS:RTK:BASE<st>:LOCATION:COORDINATES:DECIMAL[:WGS]` on page 397

9.5 RTK antenna configuration

Access:

- ▶ Select "GNSS" > "RTK Configuration" > "Antenna Configuration".

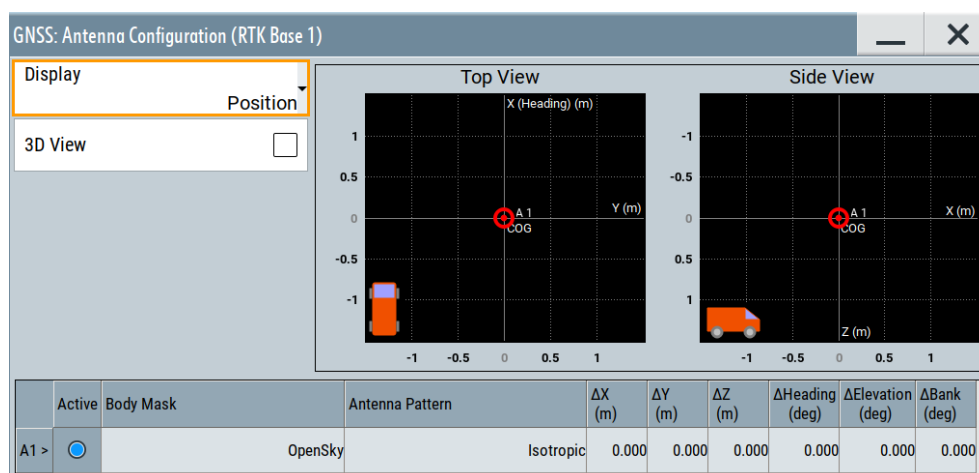

The dialog provides settings to configure the antenna body and antenna pattern of a real-time kinematics (RTK) base station.

Settings:

Display..... 161
 3D View..... 162
 A x..... 162
 Active..... 162
 Body Mask, Antenna Pattern..... 162
 Delta X, Delta Y, Delta Z..... 162
 Delta Heading, Delta Elevation, Delta Bank..... 163
 Edit > Body Mask/Antenna Pattern File..... 163

Display

Select the antenna characteristics that are currently visualized.

If more than one antenna is enabled (e.g. "Receiver > Number of Antennas = 2"), the displayed information corresponds to the currently selected one ("A# > Active > On").

The graph is merely a visualization. To change the values, select "A# > Filename > Select Antenna Pattern File > Predefined/User Files" > "Edit".

"Position" Two displays that visualize the antenna position relative to the center of gravity (COG):

- On the left, the top view - shows the x/y direction.
- On the right, the side view - shows the x/z direction.

To change the antenna position, set the parameters " ΔX , ΔY , ΔZ ".

"Body Mask" Visual representation of the body mask retrieved from the selected file ("Body Mask").

"Antenna Pattern (Attenuation), Antenna Pattern (Phase)"
 Visual representation of the attenuation/phase distribution as retrieved from the selected antenna pattern file ("Antenna Pattern").

Remote command:

```
[ :SOURce<hw> ] :BB:GNSS:RECeiver [ :V<st> ] :ANTenna:DISPlay on page 391  

[ :SOURce<hw> ] :BB:GNSS:RTK:BASE<ch>ANTenna:DISPlay
```

3D View

Displays an interactive 3D representation of the body mask or the power/phase distribution the antenna.

Remote command:

`[:SOURCE<hw>] :BB:GNSS:RECEIVER[:V<st>] :ANTenna:V3D` on page 391

A x

Subsequent antenna number. It also selects the antenna whose pattern or body mask is visualized.

Active

- In "System Config > Mode > Standard", activates the antenna and thus defines which antenna is simulated.
- Option: R&S SMW-B9
In "System Config > Mode > GNSS Advanced", select "Stream# > A1" to define which antenna is simulated by which stream.

Remote command:

`[:SOURCE<hw>] :BB:GNSS:RECEIVER[:V<st>] :A<ch>:STATE` on page 392

`[:SOURCE<hw>] :BB:GNSS:RTK:BASE<st>:A<ch>:STATE` on page 400

Body Mask, Antenna Pattern

Displays the selected body mask and antenna pattern files.

To change a file, select its filename.

You access the standard "Select Antenna Pattern File" dialog to select (or edit) the file, describing the body mask or the antenna pattern (*.ant_pat and *.body_mask). Several predefined antenna patterns are provided but you can load your own files ("User Files"), too.

The "Select Antenna Pattern File" displays both, a list of available files and the content of the selected file.

Select "Edit" to open a graphical editor for changing the file content.

See:

- [Edit > Body Mask/Antenna Pattern File](#)
- [Chapter A.3, "Antenna pattern and body mask files"](#), on page 663.

Remote command:

`[:SOURCE<hw>] :BB:GNSS:APATTERN:CATALOG:PREDEFINED?` on page 391

`[:SOURCE<hw>] :BB:GNSS:APATTERN:CATALOG:USER?` on page 391

`[:SOURCE<hw>] :BB:GNSS:RECEIVER[:V<st>] :A<ch>:APATTERN:FILE`
on page 392

`[:SOURCE<hw>] :BB:GNSS:BODY:CATALOG:PREDEFINED` on page 391

`[:SOURCE<hw>] :BB:GNSS:BODY:CATALOG:USER` on page 391

`[:SOURCE<hw>] :BB:GNSS:RECEIVER[:V<st>] :A<ch>:BODY:FILE` on page 392

`[:SOURCE<hw>] :BB:GNSS:RTK:BASE<st>:A<ch>:APATTERN:FILE` on page 399

`[:SOURCE<hw>] :BB:GNSS:RTK:BASE<st>:A<ch>:BODY:FILE` on page 399

Delta X, Delta Y, Delta Z

Sets an offset relative to the center of gravity (COG) to place the antenna.

Remote command:

[:SOURce<hw>] :BB:GNSS:RECeiver [:V<st>] :A<ch>:DX on page 393

[:SOURce<hw>] :BB:GNSS:RECeiver [:V<st>] :A<ch>:DY on page 393

[:SOURce<hw>] :BB:GNSS:RECeiver [:V<st>] :A<ch>:DZ on page 393

[:SOURce<hw>] :BB:GNSS:RTK:BASE<st>:A<ch>:DX on page 400

[:SOURce<hw>] :BB:GNSS:RTK:BASE<st>:A<ch>:DY on page 400

[:SOURce<hw>] :BB:GNSS:RTK:BASE<st>:A<ch>:DZ on page 400

Delta Heading, Delta Elevation, Delta Bank

Displays the information on the antenna orientation and tilt.

Remote command:

[:SOURce<hw>] :BB:GNSS:RECeiver [:V<st>] :A<ch>:DHEADING on page 392

[:SOURce<hw>] :BB:GNSS:RECeiver [:V<st>] :A<ch>:DELEVATION

on page 392

[:SOURce<hw>] :BB:GNSS:RECeiver [:V<st>] :A<ch>:DBANK on page 392

Edit > Body Mask/Antenna Pattern File

Access: "Antenna Configuration > A# > Body Mask > Open Sky > Select Antenna Pattern File > Predefined/User Files", select the body mask description file and select "Edit".

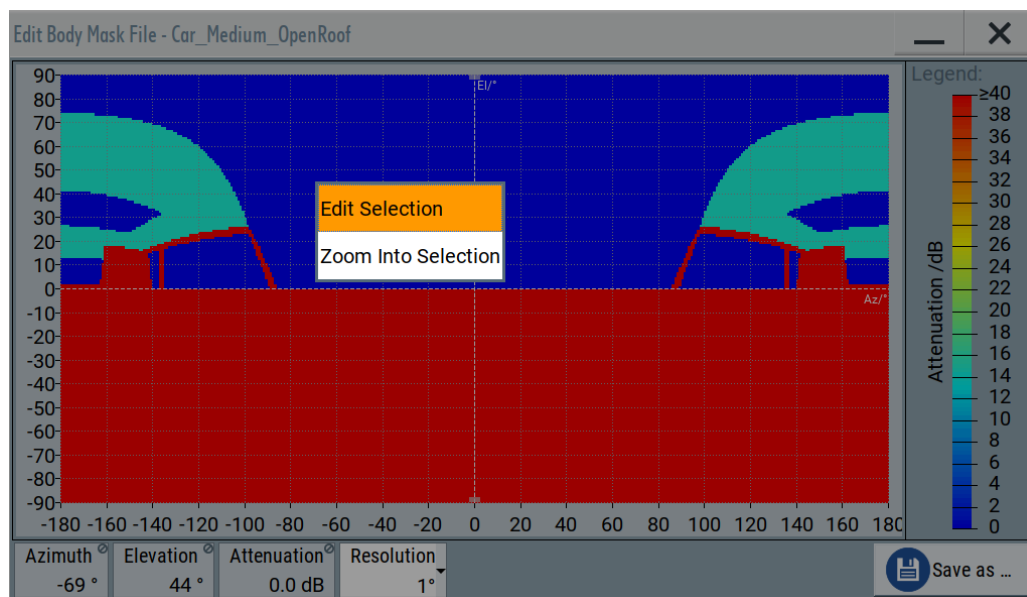

In this dialog you can change the file content, e.g. attenuation values, and zoom in into display areas.

10 Generating Galileo OSNMA signals

This chapter provides information on generating Galileo open service navigation message authentication (OSNMA) signals. For signal generation, the R&S SMW200A firmware uses specified OSNMA test vectors.

- [About OSNMA](#)..... 164
- [Generating Galileo OSNMA real-time signals](#)..... 166
- [Generating Galileo OSNMA test vector signals](#)..... 178

10.1 About OSNMA

Open service navigation message authentication (OSNMA) is an integral function of the Galileo Open Service, providing data authentication to all enabled receivers.

OSNMA is authenticating data for geolocation information from the Open Service through the navigation message (I/NAV) broadcast on the E1B signal component. For authentication, the transmitted E1 I/NAV message contains authentication-specific data in previously reserved fields.

Reference information

For OSNMA reference information, see latest versions of the following documents at the European GNSS service center ([Galileo ICD](#)):

<https://www.gsc-europa.eu/electronic-library/programme-reference-documents>

Relevant documents:

- "Galileo OSNMA SIS ICD"
- "Galileo OSNMA Receiver Guidelines"
- "Annex B - OSNMA Test Vectors" provided as *.zip file

Copyright information

The OSNMA Receiver Guidelines is protected by copyright. Any alteration or translation in any language of the OSNMA Receiver Guidelines as a whole or parts of it is prohibited unless the Publishing Authority provides a specific written prior permission. The OSNMA Receiver Guidelines may only be partly or wholly reproduced and/or transmitted to a third party in accordance with the herein described permitted use and under the following conditions:

- the present "Terms of Use and Disclaimers" are accepted, reproduced and transmitted entirely and unmodified together with the reproduced and/or transmitted information;
- the copyright notice "© European Union 2024" is not removed from any page.

The Annex to the OSNMA Receiver Guidelines provides the test vectors and sample data, supporting the verification of OSNMA functionality implementation. The Terms of Use and Disclaimers from the OSNMA Receiver Guidelines are applicable to these files.

Required options

For generating Galileo OSNMA signals, the basic equipment including the Galileo system option R&S SMW-K66 is sufficient. See [Chapter 2.1, "Required options"](#), on page 17.

10.1.1 About Galileo OSNMA real-time signals

The R&S SMW200A firmware provides real-time signal generation of OSNMA signals in line with Galileo OSNMA signal in space interface control document, see ["Reference information"](#) on page 164.

OSNMA navigation message data

OSNMA navigation message data is common to all space vehicles of a given Galileo satellite constellation. The R&S SMW200A provides settings to configure OSNMA data in a common dialog within the Galileo satellite constellation, see [Chapter 10.2, "Generating Galileo OSNMA real-time signals"](#), on page 166.

10.1.2 About Galileo OSNMA test vectors

The R&S SMW200A firmware provides official OSNMA test vectors as specified by EUSPA including satellite constellation and testing times. These test vectors allow standardized tests of the OSNMA receiver capabilities, see ["Reference information"](#) on page 164.

The tables [Table 10-1](#) and [Table 10-2](#) list supported OSNMA test vectors including the related scenario. See also ["To load a Galileo OSNMA scenario"](#) on page 178.

Table 10-1: OSNMA test vectors

Test vector Scenario name	Merkle root	Key value (without line feed)
Configuration A OSNMA: Configuration 1	Key 1	0E63F552C8021709043C239032E9FE94 1BF22C8389032F5F2701E0FBC80148B8
Configuration B OSNMA: Configuration 2	Key 2	A10C440F3AA62453526DB4AF76DF8D94 10D35D8277397D7053C700D192702B0D

Table 10-2: Galileo OSNMA test vectors for test phase

Test vector Scenario name	Merkle tree	PKID	NPKID	Public key curve
Configuration A OSNMA: Configuration A	1	2	N/A	ECDSA P-256/SHA-256
Configuration B OSNMA: Configuration B	1	3	N/A	ECDSA P-256/SHA-256
Configuration C OSNMA: Configuration C	2	8	N/A	ECDSA P-521/SHA-256

Test vector Scenario name	Merkle tree	PKID	NPKID	Public key curve
Configuration D OSNMA: Configuration D	3	2	N/A	ECDSA P-256/SHA-256
End of Chain Step 1 OSNMA: EOC_step_1	1	3	N/A	ECDSA P-256/SHA-256
End of Chain Step 2 OSNMA: EOC_step_2	1	3	N/A	ECDSA P-256/SHA-256
New Public Key Step 1 OSNMA: NPK_step_1	1	3	4	ECDSA P-256/SHA-256
New Public Key Step 2 OSNMA: NPK_step_2	1	1	2	ECDSA P-256/SHA-256
New Public Key Step 3 OSNMA: NPK_step_3	1	2	N/A	ECDSA P-256/SHA-256
Public Key Revocation Step 1 OSNMA: PKREV_step_1	1	2	3	ECDSA P-256/SHA-256
Public Key Revocation Step 2 OSNMA: PKREV_step_2	1	3	N/A	ECDSA P-256/SHA-256
Public Key Revocation Step 3 OSNMA: PKREV_step_3	1	3	N/A	ECDSA P-256/SHA-256
OSNMA Alert Message OSNMA: OAM	1	0	N/A	ECDSA P-256/SHA-256

Simulation duration and test vector length

The duration of the test vector simulations is limited by the test vector length provided in the reference documents. The simulation can run successfully only for the defined length which typically is one hour but for some scenarios, the length is two hours or three hours. For more information, see ["Reference information"](#) on page 164.

Scenario "OSNMA: PKREV_step_2" (Public Key Revocation Step 2) can only be successful when running the GNSS simulation for more than one hour. As specified in chapter A 2.5.3.2 of the ICD document "Galileo OSNMA Receiver Guidelines for Test Phase (v1.1)", an OSNMA-compatible receiver makes use of the scenario key after one hour of simulation.

10.2 Generating Galileo OSNMA real-time signals

10.2.1 Test setup

This chapter provides a test setup for Galileo OSNMA signal generation.

Signal generator

R&S SMW200A vector signal generator equipped with the Galileo system option, see "[Required options](#)" on page 165.

GNSS receiver

GNSS receiver that is compatible with Galileo OSNMA. The configuration among GNSS receivers can be different but is most likely very similar.

PC

PC with receiver control software for control and configuration of the GNSS receiver.

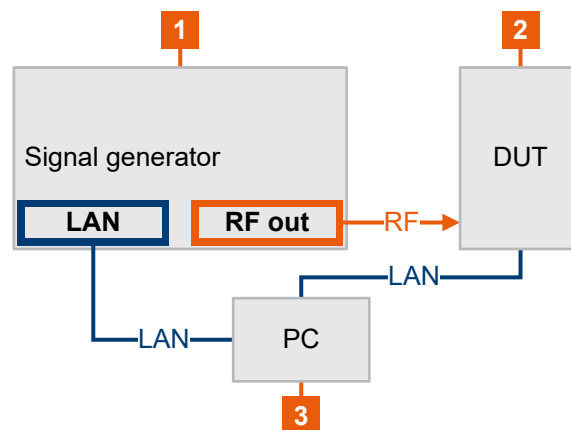

Figure 10-1: OSNMA test setup

- 1 = R&S SMW200A
- 2 = GNSS receiver
- 3 = PC with control software

10.2.2 Configuring the R&S SMW200A

This chapter provides step-by-step instructions on how to configure the R&S SMW200A for OSNMA signal generation. These instructions cover the following topics:

- "[To transfer Galileo OSNMA output files](#)" on page 167

To transfer Galileo OSNMA output files

1. Select "GNSS" > "GNSS Configuration".
2. Enable a Galileo signal. See "[Signals](#)" on page 71.
3. Open Galileo OSNMA space vehicle (SV) settings:
 - a) Select "Satellites" > "Galileo".
 - b) Select "OSNMA Configuration ...".
4. Set relevant OSNMA parameters as needed.

5. Select "GNSS" > "On".

The R&S SMW200A creates files as in the table [Table 10-3](#) at satellite simulation start. These files are available in the directory `/var/user/gnss/osnma` on the instrument.

Table 10-3: OSNMA simulation output files

File	Description
Osnma_MerkleTree_x_Bbz.txt	ASCII file of the Merkle tree (index x) in hex format. Except for Merkle tree transitions, x is always 0.
OSNMA_MerkleTree_Bbz.xml	XML file including public key and all required Merkle tree nodes at simulation start time.
OSNMA_PublicKey_Bbz.pem	PEM-encoded file of public key at simulation start time.
OSNMA_PublicKey_Bbz.xml	XML file including public key information at simulation start time.
Osnma_PublicKey_y_MerkleTree_x_Bbz.txt	ASCII file of the Public key index y (for Merkle tree index x) in hex format and corresponding Public key signature in PEM format (at simulation start time). Note that for Public key transitions, the indices of the Merkle tree x and Public Key y change. Except for Merkle tree transitions, x is always 0.
Osnma_Database_Bbz.txt	Summary of signal generator settings.

Bbz corresponds to the baseband index, for example Bb1 corresponds to baseband 1.

Load these output files at the OSNMA receiver to provide the receiver with additional settings like Public Key or Merkle root. Note, that the Public Key in force, together with its ID and signature algorithm, is provided in the DSM-PKR every 6 hours (starting at 00:00 GST, 06:00 GST, 12:00 GST and 18:00 GST) for 30 minutes, alternated with broadcast DSM-KROOT and DSM-PKR. For more information, see the Galileo OSNMA SIS ICD [Galileo ICD](#).

10.2.3 Configuring the GNSS receiver

This chapter provides step-by-step instructions on how to configure the GNSS receiver. These instructions cover the following topics:

- ["To generate a public key"](#) on page 169
- ["Example To extract an OSNMA public key"](#) on page 169
- ["To reset the GNSS receiver"](#) on page 169
- ["To install public keys at the GNSS receiver"](#) on page 170
- ["To check for satellites with no test vector data"](#) on page 170
- ["To change simulation time and receiver position"](#) on page 170
- ["Additional hints"](#) on page 170

Configure the receiver via a receiver control software or manually, if possible.

To generate a public key

A successful Galileo OSNMA simulation requires installation of specified public keys onto the GNSS receiver. These keys are based on the Merkle Tree number and the public key ID number specified in the ICD “Galileo OSNMA Receiver Guidelines”.

1. At GSC, download the *.zip file attached to annex “Annex B - OSNMA Test Vectors”.
2. In the file, navigate to a public key directory, for example open the following:

```
../cryptographic_material/Merkle_tree1/PKID2/
OSNMA_PublicKey_20201210090026.pem
```
3. To extract the public key, copy the string between -----BEGIN PUBLIC KEY----- and -----END PUBLIC KEY----- without line feed. See [Example "To extract an OSNMA public key"](#) on page 169.
4. Copy the key to the GNSS receiver.

Tip: For scenarios with two public keys like “New Public Key Step 1” copy two keys to the GNSS receiver. For example, copy keys as specified for Merkle Tree number 1, PKID number 3 and PKID number 4.

Example: To extract an OSNMA public key

This example illustrates how to extract a public key from the file OSNMA_PublicKey_20201210090026.pem.

```
-----BEGIN EC PARAMETERS-----
BggqhkJOPQMBBw==
-----END EC PARAMETERS-----
-----BEGIN PUBLIC KEY-----
MFkwEwYHKoZIzj0CAQYIKoZIzj0DAQcDQgAErUzcTNDcVbMmNTrRm9NmnggsRmsp
tpJ9ne09GTKFpYv/BJpNNMYQykoULWjvAkqF2U7XM/72CXdjKKzy/eAnYA==
-----END PUBLIC KEY-----
```

To extract the public key, copy the following string without line feed:

```
MFkwEwYHKoZIzj0CAQYIKoZIzj0DAQcDQgAErUzcTNDcVbMmNTrRm9NmnggsRmsptpJ9ne09GTKFpYv/
BJpNNMYQykoULWjvAkqF2U7XM/72CXdjKKzy/eAnYA==
```

To reset the GNSS receiver

1. Reset the receiver.
2. Also, reset the following data at the receiver:
 - Position, velocity and timing (PVT) data
 - Satellite data
 - Signal in space authentication data

We recommend a hard reset before running the receiver test.

To install public keys at the GNSS receiver

1. At the receiver, activate OSNMA usage.
2. Transfer a valid public key to the receiver.
For example, enter a valid public key as in [Example "To extract an OSNMA public key"](#) on page 169.
3. While running receiver tests, make sure that the receiver is active and ready for receiver the GNSS signal.

When receiving the GNSS signal, the receiver acquires the satellites after several minutes until it verifies the OSNMA.

To check for satellites with no test vector data

Some satellites of an OSNMA scenario are active but carry no test vector data. For example, SV 18 in scenario "OSNMA: Configuration B". These satellites were visible at the date of simulation but are not specified with test vector data by EUSPA.

1. If the GNSS receiver does not authenticate all satellites, check the satellite constellation at the R&S SMW200A.
Reasons for non-authentication at the receiver can be as follows:
 - The visibility state of the satellite changes within the simulation while running the scenario.
 - The GNSS receiver position changed while running the scenario.
2. In the satellite constellation at the R&S SMW200A, deactivate affected satellites before starting or restarting the simulation.

To change simulation time and receiver position

You can change the simulation time and receiver position of a test scenario. Changing these parameters can lead to failure of authentication tests.

1. Make sure that the simulation time is within the timeframe of the test vector data. The timeframe is typically one hour.
2. Change the receiver position as needed.
When changing the receiver position, some satellites which carry no test vector data can become visible. These visible satellites are not appropriate for OSNMA receiver testing.

Additional hints

- Always reset the GNSS receiver data when starting or restarting an OSNMA test. Typically, GNSS receivers react erroneously to time jumps, for example, into the past.
- Delete previous authentication data on the GNSS receiver, if necessary and possible. Deleting ensures correct reception of OSNMA data.
- The test vector length provided in the reference documents limits the duration of the simulation of the test vectors.

Typically a simulation can run successfully for one hour.

10.2.4 OSNMA real-time configuration and settings

Access:

1. Select "GNSS" > "GNSS Configuration".
2. Enable a Galileo signal. See [Chapter 10.3.2, "Configuring the R&S SMW200A"](#), on page 178.
3. Open Galileo OSNMA space vehicle (SV) settings:
 - a) Select "Satellites" > "Galileo".
 - b) Select "OSNMA Configuration ...".

The "OSNMA Configuration" dialog opens and provides OSNMA settings for all Galileo space vehicles. These settings are in line with the specifications in the Galileo OSNMA signal-in-space interface control document, see ["Reference information"](#) on page 164.

Settings:

- [Navigation message settings](#)..... 171
- [General OSNMA settings](#)..... 172
- [TESLA key transition settings](#)..... 176
- [Public key transition settings](#)..... 177

10.2.4.1 Navigation message settings

Access:

1. Select "GNSS" > "GNSS Configuration".
2. Enable a Galileo signal. See [Chapter 10.3.2, "Configuring the R&S SMW200A"](#), on page 178.
3. Select "Satellites" > "Galileo".

Settings:

OSNMA Configuration ...

Opens the Galileo OSNMA Configuration dialog, see [Chapter 10.2.4.2, "General OSNMA settings"](#), on page 172.

Remote command:

n.a.

10.2.4.2 General OSNMA settings

Access:

1. Select "Satellites" > "Galileo".
2. Select "OSNMA Configuration ...".

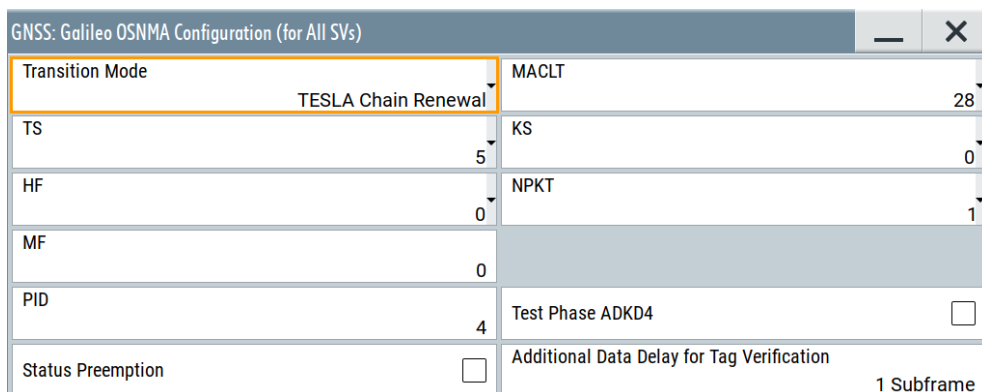

The upper part of the "OSNMA Configuration" dialog provides common OSNMA settings.

For key transition settings, see the following sections:

- [Chapter 10.2.4.3, "TESLA key transition settings"](#), on page 176
- [Chapter 10.2.4.4, "Public key transition settings"](#), on page 177

Settings:

Transition Mode	172
MACLT	173
TS	173
KS	174
HF	174
NPKT	174
MF	175
CMAC AES Key Length	175
PID	175
Test Phase ADKD4	176
Status Preemption	176
Additional Data Delay for Tag Verification	176

Transition Mode

Sets the OSNMA transition mode.

These modes define the provision for the Public Key, TESLA chain and Alert Message. Also, the modes determine the OSNMA status transitions.

"Public Key Renewal"

Public key renewal mode

"Public Key Revocation"
Public key revocation mode

"TESLA Chain Renewal"
TESLA chain renewal mode

"TESLA Chain Revocation"
TESLA chain revocation mode

"Merkle Tree Renewal"
Merkle tree renewal mode

"Alert Message"
Alert message mode

Remote command:

[\[:SOURCE<hw>\]:BB:GNSS:GALileo:OSNMa:TMODe](#) on page 573

MACLT

Sets the bits in the 8-bit MAC Look-up Table (MACLT) field. MAC is the message authentication code.

Also, sets the range of the fields Tag Size (TS) and Key Size (KS). Set the "MACLT" bits before setting "TS" and "KS".

The look-up table specifies the authentication data and key delay (ADKD) type sequence for the tags provided within the MAC and key (MACK) message. The look-up table can specify a sequence for one or two MACK messages.

Remote command:

[\[:SOURCE<hw>\]:BB:GNSS:GALileo:OSNMa:MACLt](#) on page 570

TS

Sets the bits in the 4-bit Tag Size (TS) field.

This field identifies the entry of a look-up table indicating the tag length I_T in bits. Also, the TS field defines the range of the Key Size (KS) field. Set the "TS" bits before setting "KS".

Table 10-4: TS value and tag length

TS value	Tag length
0 to 4	Reserved
5	20 bits
6	24 bits
7	28 bits
8	32 bits
9	40 bits
10 to 15	Reserved

Remote command:

[\[:SOURCE<hw>\]:BB:GNSS:GALileo:OSNMa:TS](#) on page 573

KS

Sets the bits in the 4-bit Key Size (KS) field.

This field identifies the entry of a look-up table indicating the key length I_K of the chain in bits.

Table 10-5: KS value and key length

KS value	Key length
0	96 bits
1	104 bits
2	112 bits
3	120 bits
4	128 bits
5	160 bits
6	192 bits
7	224 bits
8	256 bits
9 to 15	Reserved

Remote command:

[\[:SOURCE<hw>\]:BB:GNSS:GALileo:OSNMa:KS](#) on page 569

HF

Sets the bits in the 2-bit Hash Function (HF) field.

This field identifies the hash function used for the chain as in the table below.

Table 10-6: HF value and hash function

HF value	Hash function
0	SHA-256
1	Reserved
2	SHA3-256
3	Reserved

Remote command:

[\[:SOURCE<hw>\]:BB:GNSS:GALileo:OSNMa:HF](#) on page 569

NPKT

Sets the bits in the 4-bit New Public Key Type (NPKT) field.

This field represents the signature algorithm associated with the public key provided in the digital signature message for a public key renewal (DSM-PKR).

The table below describes NPKT values and related messages. The R&S SMW200A supports "1" and "3". For an OSNMA Alert Message (OAM), select "Transition Mode" > "Alert Message", see ["Transition Mode"](#) on page 172.

Table 10-7: NPKT value and message type

NPKT value	Message
0	Reserved
1	ECDSA P-256
2	Reserved
3	ECDSA P-521
4	OSNMA Alert Message (OAM)
5 to 15	Reserved

Remote command:

`[:SOURCE<hw>] :BB:GNSS:GALileo:OSNMa:NPKT` on page 570

MF

Sets the bits in the 2-bit MAC Function (MF) field.

This field identifies the MAC Function to authenticate the navigation data.

Table 10-8: MF value and hash function

MF value	Hash function
0	HMAC-SHA-256
1	CMAC-AES
2	Reserved
3	Reserved

Remote command:

`[:SOURCE<hw>] :BB:GNSS:GALileo:OSNMa:MF` on page 570

CMAC AES Key Length

Requires "MF" = "1".

Sets the length of the cipher-based message authentication code (CMAC) key.

"CMAC(AES-128)"

The length of the CMAC key is 128 bits.

"CMAC(AES-256)"

The length of the CMAC key is 256 bits.

Remote command:

`[:SOURCE<hw>] :BB:GNSS:GALileo:OSNMa:AESKey:LENGTH` on page 568

PID

Sets the ID of the Public Key (PK) used to verify the signature of the digital signature message for a root key (DSM-KROOT).

If the transition mode defines the change of the public key, the PKID depends on the simulation time. This PKID means the public key which is in use and the PKID is increased by each public key transition.

For transition mode "Merkle Tree Renewal", the Merkle tree index alternates between 0 and 1 at each Public key transition. All other transition modes use Merkle tree index 0.

Remote command:

[\[:SOURCE<hw>\]:BB:GNSS:GALileo:OSNMa:PID](#) on page 571

Test Phase ADKD4

Enable the authentication data and key delay (ADKD) for ADKD = 4 for Galileo I/NAV timing parameters.

Remote command:

[\[:SOURCE<hw>\]:BB:GNSS:GALileo:OSNMa:ADKD](#) on page 568

Status Preemption

Enable the status preemption.

Enable this setting if your test setup requires an alignment of the header and root key (HKROOT) message. The alignment applies to any change of navigation message authentication (NMA) status or chain and public key status (CPKS) value.

Remote command:

[\[:SOURCE<hw>\]:BB:GNSS:GALileo:OSNMa:SPReemption](#) on page 573

Additional Data Delay for Tag Verification

Sets an additional delay in subframes of the navigation data for the tag verification. The delay can depend on receiver implementation.

You can set a delay of one subframe. A zero subframe delay corresponds to no delay.

Remote command:

[\[:SOURCE<hw>\]:BB:GNSS:GALileo:OSNMa:ADDelay](#) on page 568

10.2.4.3 TESLA key transition settings

Access:

- ▶ Select "OSNMA Configuration ..." > "TESLA Key Transition".

TESLA Keys Transition	
Number of Root Key Transitions per Day 4	Time Offset of Root Key Transition vs. Midnight 10 800 s
Chain Key Transition Duration (Step 1) 3 600 s	Chain Key Transition Duration (Step 2) 3 600 s

This section of the "OSNMA Configuration" dialog provides settings for transition of timed efficient stream loss-tolerant authentication (TESLA) keys.

Settings:

Number of Root Key Transitions per Day.....177

Time Offset of Root Key Transition vs. Midnight..... 177

Chain Key Transition Duration (Step 1).....177

Chain Key Transition Duration (Step 2).....177

Number of Root Key Transitions per Day

Sets the number of TESLA chain transitions per day.

Remote command:

[:SOURCE<hw>] :BB:GNSS:GALileo:OSNMa:RKEY:NTDay on page 572

Time Offset of Root Key Transition vs. Midnight

Sets a time offset of the TESLA chain transitions per day.

Remote command:

[:SOURCE<hw>] :BB:GNSS:GALileo:OSNMa:RKEY:TOMidnight on page 572

Chain Key Transition Duration (Step 1)

Sets the duration of step 1 for TESLA chain transitions.

Remote command:

[:SOURCE<hw>] :BB:GNSS:GALileo:OSNMa:PKEY:TDURATION:SONE on page 571

Chain Key Transition Duration (Step 2)

Sets the duration of step 2 for TESLA chain transitions.

Remote command:

[:SOURCE<hw>] :BB:GNSS:GALileo:OSNMa:PKEY:TDURATION:STWO on page 571

10.2.4.4 Public key transition settings

Access:

- ▶ Select "OSNMA Configuration ..." > "Public Key Transition".

Public Key Transition	
Number of Public Key Transitions per Day	4
Time Offset of Public Key Transition vs. Midnight	0 s
Public Key Transition Duration (Step 1)	3 600 s
Public Key Transition Duration (Step 2)	3 600 s

This section of the "OSNMA Configuration" dialog provides settings for the transition of public keys.

Settings:

Number of Public Key Transitions per Day..... 177

Time Offset of Public Key Transition vs. Midnight..... 178

Public Key Transition Duration (Step 1)..... 178

Public Key Transition Duration (Step 2)..... 178

Number of Public Key Transitions per Day

Sets the number of Public key transitions per day.

Remote command:

[:SOURCE<hw>] :BB:GNSS:GALileo:OSNMa:RKEY:NTDay on page 572

Time Offset of Public Key Transition vs. Midnight

Sets a time offset of the Public key transitions per day.

Remote command:

[\[:SOURCE<hw>\]:BB:GNSS:GALileo:OSNMa:RKEY:TOMidnight](#) on page 572

Public Key Transition Duration (Step 1)

Sets the duration of step 1 for Public key transitions.

Remote command:

[\[:SOURCE<hw>\]:BB:GNSS:GALileo:OSNMa:PKEY:TDURATION:SONE](#)
on page 571

Public Key Transition Duration (Step 2)

Sets the duration of step 2 for Public key transitions.

Remote command:

[\[:SOURCE<hw>\]:BB:GNSS:GALileo:OSNMa:PKEY:TDURATION:STWO](#)
on page 571

10.3 Generating Galileo OSNMA test vector signals

This chapter provides an overview on how to prepare, configure and operate the R&S SMW200A or multiple R&S SMW200A instruments for generation of extended bandwidth signals. It covers the following topics:

- [Test setup](#)..... 178
- [Configuring the R&S SMW200A](#)..... 178
- [Configuring the GNSS receiver](#)..... 180
- [Related settings](#)..... 180

10.3.1 Test setup

See [Chapter 10.2.1, "Test setup"](#), on page 166.

10.3.2 Configuring the R&S SMW200A

This chapter provides step-by-step instructions on how to configure the R&S SMW200A for OSNMA signal generation. These instructions cover the following topics:

- ["To load a Galileo OSNMA scenario"](#) on page 178

To load a Galileo OSNMA scenario

1. Select a predefined OSNMA scenario:
 - a) Select "Predefined Scenario" > "Galileo OSNMA" > "OSNMA".

b) Select, for example "OSNMA: Configuration 1".

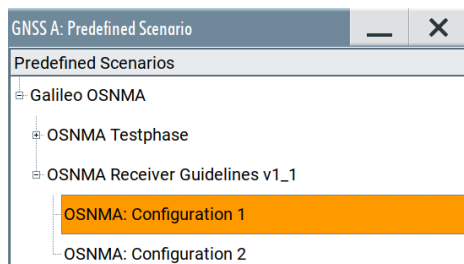

c) Confirm with "Select".

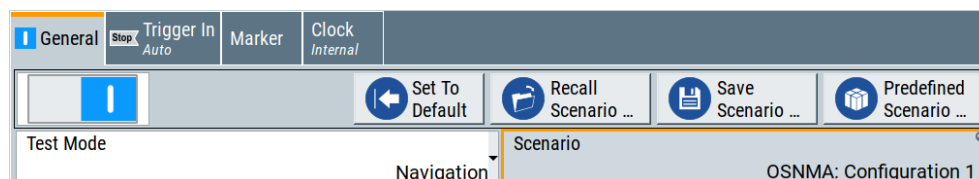

Selecting loads the scenario. The R&S SMW200A also loads test vector-specific configuration of the satellite constellation, simulation time and navigation message data. For example, the simulation date for the test vector "Configuration 1" is "2023-08-16".

2. Select "GNSS Configuration" > "System & Signals".
By default, the Galileo L1 band signal "E1 OS" is enabled.
3. Check OSNMA settings of a Galileo space vehicle (SV).
 - a) Select "Satellites" > "Galileo".
 - b) Select, for example, "SV 2" > "SV Config".

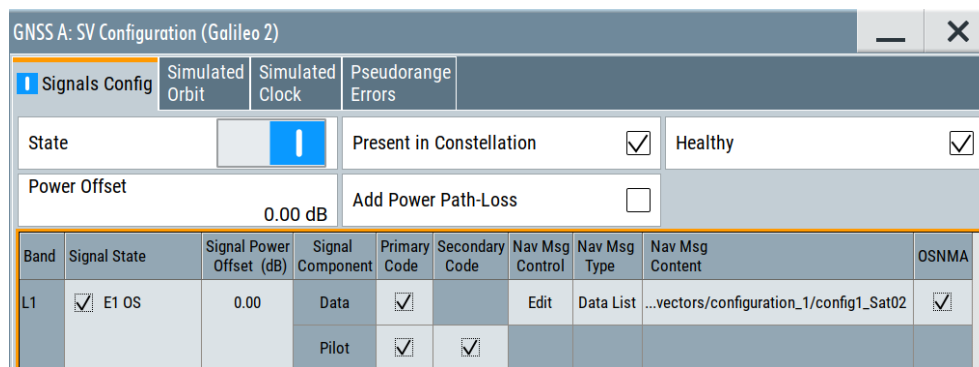

The navigation message content is predefined list mode data as specified by GSC. OSNMA coding is active.

To load predefined OSNMA scenarios remotely, see [Example "To load a Galileo OSNMA scenario"](#) on page 448.

10.3.3 Configuring the GNSS receiver

See [Chapter 10.2.3, "Configuring the GNSS receiver"](#), on page 168.

10.3.4 Related settings

Access:

1. Select a predefined OSNMA scenario. See ["To load a Galileo OSNMA scenario"](#) on page 178.
2. Access OSNMA settings of a Galileo space vehicle (SV).
 - a) Select "Satellites" > "Galileo".
 - b) Select, for example, "SV 2" > "SV Config".

Band	Signal State	Signal Power Offset (dB)	Signal Component	Primary Code	Secondary Code	Nav Msg Control	Nav Msg Type	Nav Msg Content	OSNMA
L1	<input checked="" type="checkbox"/> E1 OS	0.00	Data	<input checked="" type="checkbox"/>		Edit	Data List	...vectors/configuration_1/config1_Sat02	<input checked="" type="checkbox"/>
			Pilot	<input checked="" type="checkbox"/>	<input checked="" type="checkbox"/>				

The table provides settings to enable OSNMA coding for the navigation message content of the predefined OSNMA scenarios.

Settings:

OSNMA

Enables coding of the OSNMA content of the Galileo navigation message for the predefined OSNMA scenarios.

Remote command:

`[:SOURCE<hw>] :BB:GNSS:SVID<ch>:GALileo:SIGNal:L1Band:E1OS:DATA:OSNM a [:STATe]` on page 474

11 Tracking mode

Per default, the R&S SMW200A generates a GNSS signal that is suitable for testing the receiver capabilities to acquire and track the signal and to estimate its position based.

Some receiver tests, however, focus on testing if the receiver is capable to acquire and decode the signal; navigation and thus position estimation is not necessary. For such tests or for receivers' sensitivity tests in zero Doppler conditions or under varying signal dynamics conditions, the R&S SMW200A provides the tracking mode.

With the provided signal dynamic settings, you can enable a predefined or constant velocity profile, or define a user-specific one.

11.1 Signal dynamics settings

Access:

1. Select "GNSS" > "Test Mode" > "Tracking".
2. Select "GNSS" > "GNSS Configuration" > "Satellites".
3. Select the GNSS system for that you want to configure satellites constellation, for example GPS.
4. Select "SV#" > "SV Config".
5. In the "SV Configuration" dialog, select **Signal Dynamics**.
6. Select, for example "Mode" > "High Order".

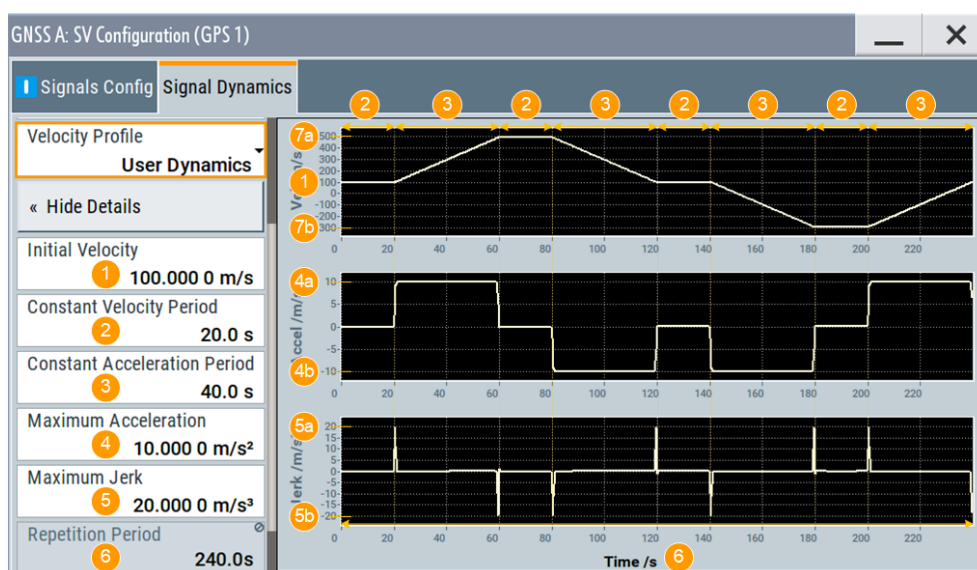

Figure 11-1: Understanding high-order user-defined signal dynamics

- 1 = Velocity at the start of the profile
- 2 = Period of time the velocity is held constant
- 3 = Period of time an acceleration is applied
- 4 = Maximum acceleration together with the acceleration period and, if set the initial velocity, defines the maximum velocity (7a and 7b)
- 5 = Defines how fast the maximum acceleration is reached
- 6 = Profile's duration, calculated from the selected periods of constant speed and acceleration; the profile is repeated every 240 s.
- 7a = Maximum velocity = "Initial Velocity" + "Constant Acceleration Period"."Maximum Acceleration" = 500 m/s
- 7b = "Initial Velocity" - "Constant Acceleration Period"."Maximum Acceleration"

Signal dynamics settings are provided for testing the receiver sensitivity under varying signal dynamics conditions. You can select a predefined or constant velocity profile, or define a user-specific one.

The displayed settings depend on the selected "Mode" and "Velocity Profile". Dedicated plots visualize the variations of the velocity, acceleration and the jerk over time.

Settings:

Mode.....	182
Initial Pseudorange.....	182
Initial Carrier Phase (L1).....	183
Velocity (Pseudorange Rate).....	183
High-order profile settings.....	183
L Start Time Offset.....	183
L Velocity Profile.....	183
L Show Details/Hide Details.....	183
L Initial Velocity (Pseudorange Rate).....	184
L Constant Velocity Period.....	184
L Constant Acceleration Period.....	184
L Maximum Acceleration.....	184
L Maximum Jerk.....	184
L Repetition Period.....	184

Mode

Selects the dynamics profile type.

- "Constant" Generates a constant velocity profile with configurable velocity, see [Velocity \(Pseudorange Rate\)](#).
This mode is suitable for testing the receiver characteristics under more realistic conditions than with zero Doppler.
- "High Order" Enables profiles with higher-order dynamics.
There are two predefined profiles and you can define your own one, see [High-order profile settings](#).

Remote command:

[:SOURCE<hw>] :BB:GNSS:SVID<ch>:GPS:SDYNAMICS:PROFILE on page 590
(etc. for the other GNSS systems)

Initial Pseudorange

Sets the pseudorange at the beginning of the simulation.

Remote command:

[:SOURce<hw>] :BB:GNSS:SVID<ch>:GPS:SDYNamics:PRANge on page 591

Initial Carrier Phase (L1)

Sets the carrier phase at the beginning of the simulation.

Remote command:

[:SOURce<hw>] :BB:GNSS:SVID<ch>:GPS:SDYNamics:CPHase on page 591

Velocity (Pseudorange Rate)

In "Mode = Constant", sets the velocity, i.e. the constant Doppler with that the pseudorange changes. The pseudorange at a give moment is calculated from the initial pseudorange value and the velocity.

Velocity different than zero results in variation of the Doppler shift.

The velocity is constant, hence the acceleration and the jerk are zero. Observe also the indications on the plots.

Remote command:

[:SOURce<hw>] :BB:GNSS:SVID<ch>:GPS:SDYNamics:VELocity on page 592
(etc. for the other GNSS systems)

High-order profile settings

In "Mode" = "High Order", observe the plots indicating the variations of the velocity, acceleration and the jerk over time, see [Figure 11-1](#).

For both predefined profiles ("Velocity Profile" = "Low Dynamics" or "High Dynamics"), the profile settings are read-only. To change the settings, set "Velocity Profile" = "User Dynamics".

Start Time Offset ← High-order profile settings

Sets a time delay before the dynamics profile is applied.

Remote command:

[:SOURce<hw>] :BB:GNSS:SVID<ch>:GPS:SDYNamics:TOFFset on page 592
(etc. for the other GNSS systems)

Velocity Profile ← High-order profile settings

Selects between the predefined velocity profiles or a user-defined one.

"Low Dynamics"/"High Dynamics"

Generates a profile using the settings of one of the predefined velocity profiles.

"User Dynamics"

Generates a velocity profile with user-defined parameters.

Remote command:

[:SOURce<hw>] :BB:GNSS:SVID<ch>:GPS:SDYNamics:CONFig on page 593
(etc. for the other GNSS systems)

Show Details/Hide Details ← High-order profile settings

Shows or hides the following settings:

- "Initial Velocity (Pseudorange Rate)" on page 184
- "Constant Velocity Period" on page 184

- "Constant Acceleration Period" on page 184
- "Maximum Acceleration" on page 184
- "Maximum Jerk" on page 184
- "Repetition Period" on page 184

Remote command:

n.a.

Initial Velocity (Pseudorange Rate) ← High-order profile settings

Indicates the start velocity, used at the beginning of the profile. This value is used at the simulation start time or after the defined "Start Time Offset" elapses, see [Figure 11-1](#).

Remote command:

[:SOURCE<hw>] :BB:GNSS:SVID<ch>:GPS:SDYNAMICS:IVELocity on page 593
(etc. for the other GNSS systems)

Constant Velocity Period ← High-order profile settings

Displays the time period during which that velocity is kept constant and the acceleration is assumed to be 0.

Remote command:

[:SOURCE<hw>] :BB:GNSS:SVID<ch>:GPS:SDYNAMICS:CVPeriod on page 594
(etc. for the other GNSS systems)

Constant Acceleration Period ← High-order profile settings

Displays the time duration during which that acceleration is applied and thus the velocity varies.

The acceleration is calculated from the "Maximum Jerk" and the "Maximum Acceleration".

Remote command:

[:SOURCE<hw>] :BB:GNSS:SVID<ch>:GPS:SDYNAMICS:CAPeriod on page 594
(etc. for the other GNSS systems)

Maximum Acceleration ← High-order profile settings

Indicates the maximum acceleration. This value together with the acceleration period and, if set the initial velocity, defines the maximum velocity.

Remote command:

[:SOURCE<hw>] :BB:GNSS:SVID<ch>:GPS:SDYNAMICS:ACCEL:MAX on page 595
(etc. for the other GNSS systems)

Maximum Jerk ← High-order profile settings

Indicates the maximum jerk that defines how fast the maximum acceleration is reached.

Remote command:

[:SOURCE<hw>] :BB:GNSS:SVID<ch>:GPS:SDYNAMICS:JERK:MAX on page 595
(etc. for the other GNSS systems)

Repetition Period ← High-order profile settings

Indicates the profile duration. The value is calculated automatically.

Remote command:

[:SOURCE<hw>] :BB:GNSS:SVID<ch>:GPS:SDYNameics:RPERiod? on page 596
(etc. for the other GNSS systems)

11.2 Related settings

Configured for tracking mode, the R&S SMW200A requires only a subset of a GNSS multifrequency constellation simulator.

To access related settings for tracking mode, proceed as follows:

- "SV selection configuration settings" on page 185
- "Additional settings" on page 185

The description of the related settings is linked at the end of each procedure.

SV selection configuration settings

Access:

1. Select "GNSS" > "GNSS Configuration".
2. Select "Satellites" > "SV Selection Configuration".

	Number of SVs		
	Min	Max	Current
GPS	0	24	11
Galileo	0	24	8
GLONASS	0	24	9
BeiDou	0	24	12
QZSS	0	3	0
NavIC	0	6	3
Maximum Number of Channels			102

The settings are read-only except for the minimum and maximum number of space vehicles.

For a description of the settings, see [Chapter 6.3, "Space vehicle selection configuration"](#), on page 77. For information on the maximum number of GNSS channels, see [Chapter G, "Channel budget"](#), on page 682.

Additional settings

Configure GNSS systems and signals, simulation time, signal power, navigation message, perturbation and data logging settings as described in this user manual.

For a description of these settings, see the following sections:

- [Chapter 6.1, "Systems and signals settings"](#), on page 69

- [Chapter 4.1, "Time settings"](#), on page 46
- [Chapter 7.1, "Power settings"](#), on page 83
- [Chapter 13, "Perturbations and errors simulation"](#), on page 192
- [Chapter 16, "Data logging"](#), on page 289

12 Matched-spectrum GNSS interferer

Key features

The option R&S SMW-K129 matched-spectrum GNSS interference test features:

- Generation of GNSS interference signals for available GNSS channels
- Simulation of up to 612 GNSS channels
- Simulation of correct PRN sequences and modulation of available GNSS signals and systems without navigation
- Matched-spectrum GNSS interferer test signals for navigation mode
- Matched-spectrum GNSS interferer test signals for tracking mode

The maximum number of simulated GNSS channels depends on the installed hardware and GNSS system options, see [Chapter G, "Channel budget"](#), on page 682. Extending the simulation capacity requires no installation of the additional channel options "Add x GNSS channels".

About the matched-spectrum GNSS interferer

Equipped with the option R&S SMW-K129, the R&S SMW200A generates interference test signals for a given satellite constellation. Also, the simulation extends the number of available GNSS channels to up to 612 channels depending on the installed hardware options. For all these GNSS channels, the navigation data generation is disabled. Data logging and real-time kinematics (RTK) simulation are not available.

This special test option allows generation of GNSS signals with correct PRN sequences and modulation for all enabled GNSS signals. You can simulate these signals based on a realistic satellite constellation and user motion. Use the generated signals for GNSS interference tests. Note that the simulation cannot calculate position, velocity and timing (PVT) data of the GNSS receiver based on the generated signals. But the signals can be sufficient for a position fix of the GNSS test receiver.

For GNSS receivers in tracking mode, the R&S SMW200A provides the test mode "Matched-Spectrum GNSS Interferer". For GNSS receivers in navigation mode, the R&S SMW200A provides the test mode "Advanced Matched-Spectrum GNSS Interferer".

The following sections provide information on required options and related settings to generate match-spectrum interference signals.

- [Required options](#)..... 187
- [Related settings](#)..... 188

12.1 Required options

The equipment for generating matched-spectrum GNSS interferer test signals includes the R&S SMW200A equipped with the options as described in the table below.

Option	Designation
R&S SMW-B9	Wideband baseband generator
R&S SMW-B13XT	Wideband main module
R&S SMW-K<x> ¹⁾	GNSS system option
R&S SMW-K129	Matched-spectrum GNSS interference test

¹⁾ K<x> denotes a GNSS system option: R&S SMW-K44/K66/K94/K97/K98/K107/K132

See also [Chapter 2.1, "Required options"](#), on page 17.

12.2 Related settings

Configured for matched-spectrum GNSS interferer signal generation, the R&S SMW200A requires only a subset of the GNSS settings.

To open related settings for matched-spectrum interferer modes, proceed as follows:

- ["GNSS general settings"](#) on page 188
- ["SV selection configuration settings"](#) on page 185
- ["GNSS navigation message settings"](#) on page 189
- ["GLONASS navigation message settings"](#) on page 190
- ["Additional settings"](#) on page 191

The description of the related settings is linked at the end of each procedure.

GNSS general settings

Access:

- ▶ Select "GNSS" > "Test Mode":
 - a) Select "Matched-Spectrum Interferer" for tracking mode GNSS receivers.
 - b) Select "Advanced Matched-Spectrum Interferer" for navigation mode GNSS receivers.

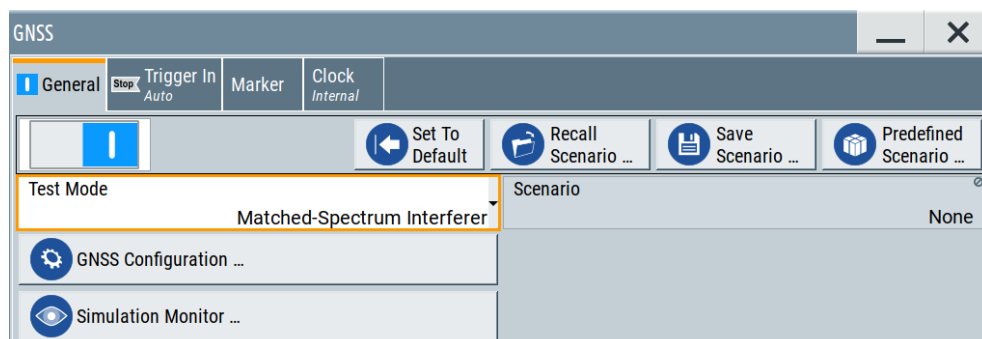

The dialog provides general settings to generate matched-spectrum GNSS interferer signals. Generating these signals requires only a subset of the general settings. Data logging and real-time kinematics (RTK) configuration are not available. For a description of the settings, see [Chapter 3.2, "General settings"](#), on page 32.

SV selection configuration settings

Access:

1. Select "GNSS" > "GNSS Configuration".
2. Select "Satellites" > "SV Selection Configuration".

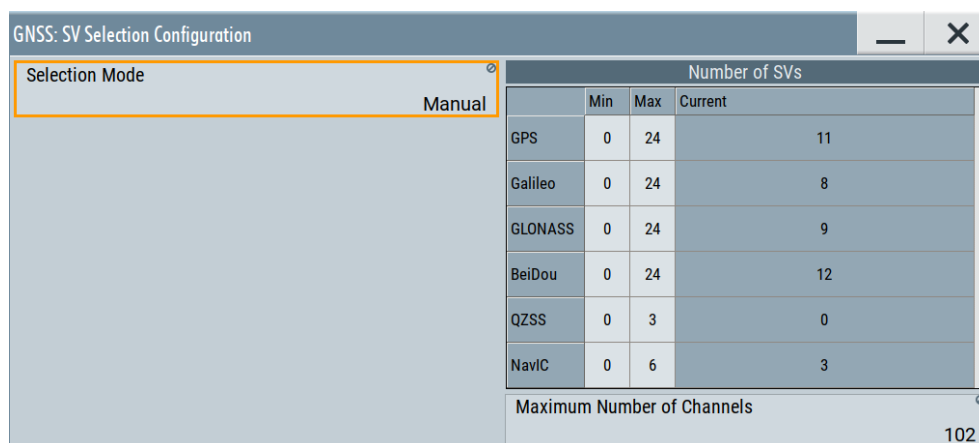

The settings are read-only except for the minimum and maximum number of space vehicles.

For a description of the settings, see [Chapter 6.3, "Space vehicle selection configuration"](#), on page 77. For information on the maximum number of GNSS channels, see [Chapter G, "Channel budget"](#), on page 682.

GNSS navigation message settings

Access:

1. Select "GNSS" > "GNSS Configuration".

Equipped with option R&S SMW-K44, the default system is GPS with enabled L1 band and C/A signal. The following steps illustrate GPS navigation message settings. The navigation message settings for other GNSS are analogous.

2. Select "Satellites" > "SV ID 1" > "SV Config".

The "SV Configuration" dialog opens for the related space vehicle ("GPS 1").

Band	Signal State	Signal Power Offset (dB)	Signal Component	Primary Code	Secondary Code	Nav Msg Control	Nav Msg Type	Nav Msg Content
L1	<input checked="" type="checkbox"/> C/A	0.00	Data	<input checked="" type="checkbox"/>		Off		

The SV signal configuration table displays disabled navigation message settings because the navigation data generation is disabled. The interference signals have correct PRN sequences and modulation but contain no navigation message data. The table below illustrate the navigation message settings.

Parameter	Value
"Nav Msg Control"	"Off"
"Nav Msg Type"	-
"Nav Msg Content"	-

For a description of the settings, see [Chapter 7.2, "Modulation control settings"](#), on page 88.

GLONASS navigation message settings

The following step-by-step instruction illustrates additional navigation message settings that are specific to the GLONASS FDMA "C/A" signals in "L1" band or "L2" band. These signals require the GLONASS system option R&S SMW-K94.

Access:

1. Select "GNSS" > "GNSS Configuration".
2. In the "Systems & Signals" tab, enable GLONASS C/A signals:
 - a) Select "L1 Band" > "On".
 - b) Select "System" > "GLONASS" > "On".
 - c) Select "Signals" > "C/A" > "On".
 - d) Optionally with R&S SMW-K123, select "Signals" > "CDMA L1" > "On".
3. Select "Satellites" > "GLONASS" > "SV ID 1" > "SV Config".

The "SV Configuration" dialog opens for the related space vehicle ("GLONASS 1").

Band	Signal State	Signal Power Offset (dB)	Signal Component	Primary Code	Secondary Code	Nav Msg Control	Nav Msg Type	Nav Msg Content	Meander Sequence	Time Sequence
L1	<input checked="" type="checkbox"/> C/A	0.00	Data	<input checked="" type="checkbox"/>		Edit	Pattern	01		
	<input checked="" type="checkbox"/> CDMA L1		Data	<input checked="" type="checkbox"/>	<input checked="" type="checkbox"/>	Edit	All 0			
			Pilot	<input checked="" type="checkbox"/>						

The SV signal configuration table displays fixed navigation message settings for GLONASS L1 signals. The interference signals have correct PRN sequences and modulation but contain no realistic navigation message data. For FDMA signals, the table displays a fixed pattern "01" to compensate for missing meander sequences and missing correlation energy. For non-FDMA signals, for example "CDMA L1", the table displays zero navigation message data ("Nav Msg Type" > "All 0").

The table below illustrate the navigation message settings for both signal types.

Signal	Parameter	Value
"C/A"	"Nav Msg Control"	"Edit"
"C/A"	"Nav Msg Type"	"Pattern"
"C/A"	"Nav Msg Content"	"01"
"CDMA L1"	"Nav Msg Control"	"Edit"

Signal	Parameter	Value
"CDMA L1"	"Nav Msg Type"	"All 0"
"CDMA L1"	"Nav Msg Content"	-

For a description of the settings, see [Chapter 7.2, "Modulation control settings"](#), on page 88.

Additional settings

Configure GNSS systems and signals, simulation time, signal power, navigation message, perturbation and data logging settings as described in this user manual.

For a description of these settings, see the following sections:

- [Chapter 6.1, "Systems and signals settings"](#), on page 69
- [Chapter 4.1, "Time settings"](#), on page 46
- [Chapter 7.1, "Power settings"](#), on page 83
- [Chapter 13, "Perturbations and errors simulation"](#), on page 192

13 Perturbations and errors simulation

Section [Real-world environment](#) deals with the impact of the multipath and other environment effects on the position accuracy.

Real receivers experience also perturbations such as noise, interfering signals, atmospheric effects and ionospheric errors. Other signal errors are caused by satellite orbit and clock errors. The errors remain non-corrected despite the corrections in the broadcasted navigation message.

To simulate even more challenging conditions, you can add deliberate signal errors by manipulating the navigation messages of the satellites. Perturbations of the signal and signal errors of any kind have a direct impact on the receiver's positioning accuracy.

The following sections illustrate error sources and settings necessary to simulate errors.

- [About noise and CW interferer](#)..... 192
- [Noise and CW interferer settings](#)..... 192
- [About error sources](#)..... 198
- [Atmospheric effects and ionospheric errors settings](#)..... 202
- [Pseudorange errors settings](#)..... 212
- [Orbit and orbit perturbation errors settings](#)..... 215
- [Clock errors settings](#)..... 223
- [Time conversion errors settings](#)..... 227
- [System errors settings](#)..... 232

13.1 About noise and CW interferer

With the R&S SMW200A equipped as a wideband generator, you can add noise or an interfering continuous wave (CW) signal to the generated GNSS signal.

Required options

Adding noise or an interfering signal to the generated GNSS signal requires the following options:

- Wideband baseband generator (R&S SMW-B9)
- Wideband baseband main module (R&S SMW-B13XT)
- AWGN (R&S SMW-K62)

See R&S SMW200A user manual, section "Adding Noise to the Signal".

13.2 Noise and CW interferer settings

Option: R&S SMW-B9 and R&S SMW-K62

See also "[Required options](#)" on page 192.

Add noise to the GNSS signal or interfere the signal. The settings allow you to apply a GNSS-specific configuration without accessing the "AWGN" block in the block diagram of the R&S SMW200A.

Access:

- ▶ Select "Simulation Configuration" > "Noise / CW Interferer".

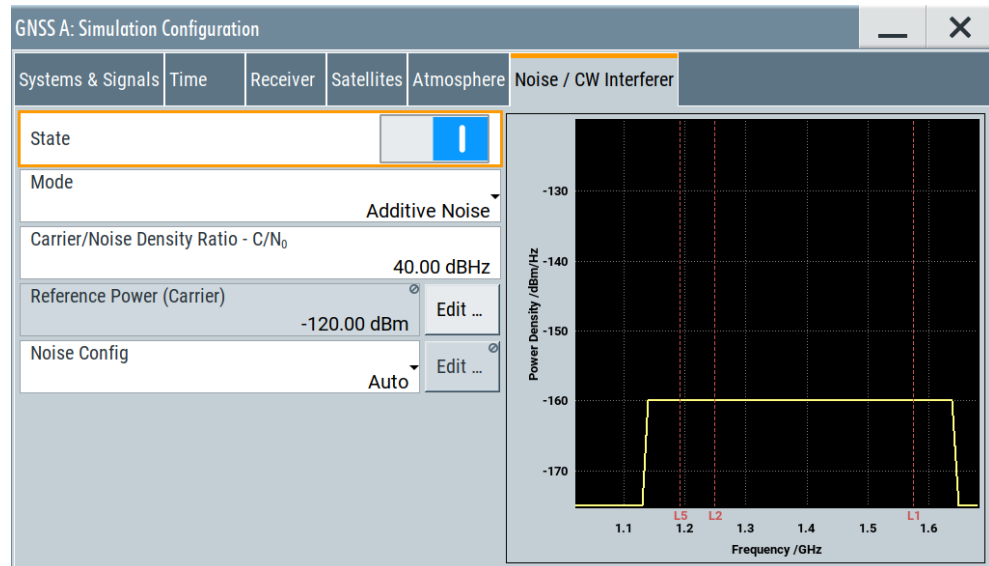

The dialog provides settings necessary to configure additive noise and an interfering CW signal. Also it displays the plotted carrier frequency versus the power density in a graph. The graph also displays the center frequencies of the L1, L2 and L5 bands via red dotted lines. Also displayed is the noise signal or CW interferer signal depending on the selected mode.

The remote commands required to define these settings are described in [Chapter 22.10, "AWGN configuration"](#), on page 434.

To add noise to a GNSS signal

1. Select "Mode > Additive Noise".
2. Set "Carrier/Noise Density Ratio - C/N_0 ".
Using the default value of 40 dBHz and reference power of -120 dBm, the power density equals -160 dBm/Hz.
3. To monitor bandwidth and center frequency of the noise signal, proceed as follows:
 - a) Select "Noise Config > Manual"
 - b) Click "Edit".

If fully equipped and all bands enabled, the noise signal covers all band signals. The signal has a bandwidth of 500 MHz at 1.389225 GHz center frequency.

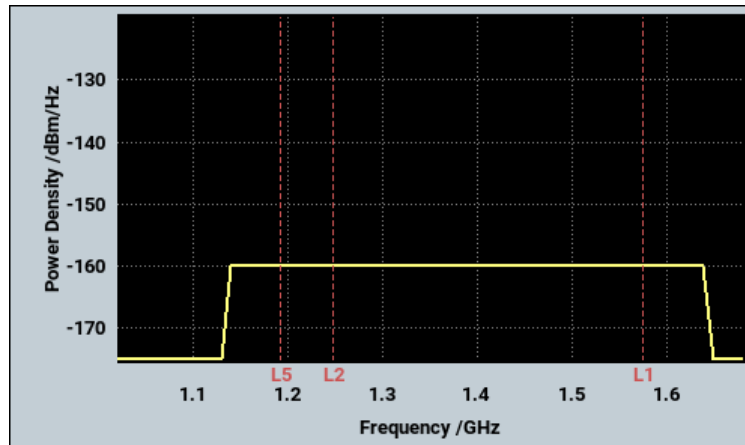

4. To add the configured noise signal, select "State > On".

The settings are automatically applied to the settings at the "AWGN" block. In the block diagram of the R&S SMW200A, the "AWGN" block displays "AWGN GNSS".



To shift noise to one RF band

We assume you configured the R&S SMW200A as in [To add noise to a GNSS signal](#) until step 2.

1. Enable one RF band only, e.g., "Systems & Signals > L1 > On" and "L2 > Off" and "L5 > Off".
2. Select "Noise Config > Auto".

The noise signal shifts automatically to the center frequency of the L1 band. The signal has a bandwidth of 75 MHz at 1.57542 GHz center frequency.

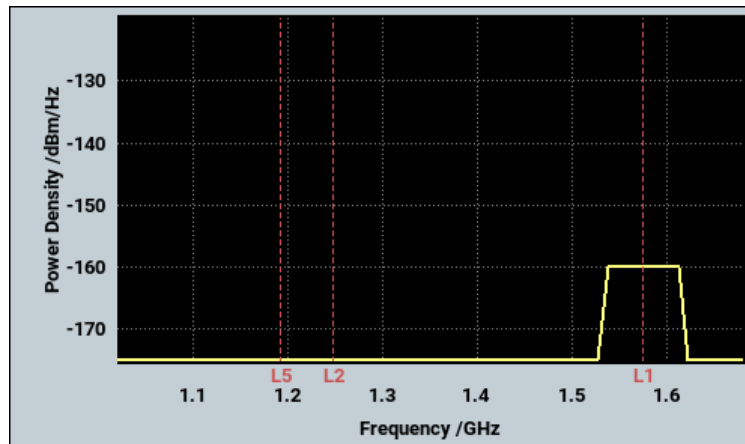

3. To shift the noise signal manually:

- a) Select "Noise Config > Manual"
 - b) Click "Edit".
4. In the "Noise Configuration" dialog, shift the noise signal by setting the "Center Frequency".

Note: Shifting the noise center frequency f_{center} depends on the bandwidth Δf_{noise} and is limited to the following range:

$$1.139225 \text{ GHz} + \Delta f_{\text{noise}}/2 \leq f_{\text{center}} \leq 1.6392245 \text{ GHz} - \Delta f_{\text{noise}}/2$$

5. To add the shifted noise signal, select "State > On".

To add a CW interferer to a GNSS signal

1. Select "Mode > CW Interferer".
2. Set "Jammer/Signal Ratio - J/S".

Using the default value of 40 dB and reference power of -120 dBm, the power level of the CW interferer signal is -80 dBm.

3. Set "CW Frequency".

By default, the frequency equals the center frequency of an RF band. E.g., with L1 enabled, it equals 1.57542 GHz. The signal is displayed as a yellow dotted line in the graph.

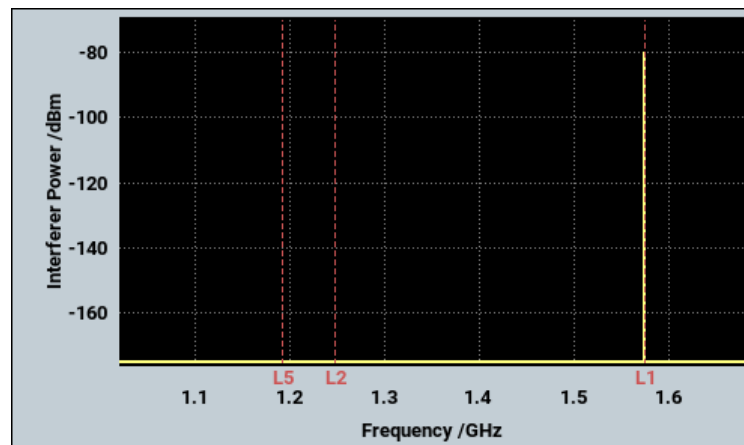

4. To add the configured CW interferer signal, select "State > On".

To add a noise and/or CW interferer in GNSS advanced mode

The procedure assumes a wideband baseband instrument equipped with options R&S SMW-K134 and R&S SMW-K<x>, see [Table 15-1](#).

1. Enable "GNSS Advanced" mode:
["To enable GNSS advanced mode"](#) on page 269
2. Select "Noise / CW Interferer".

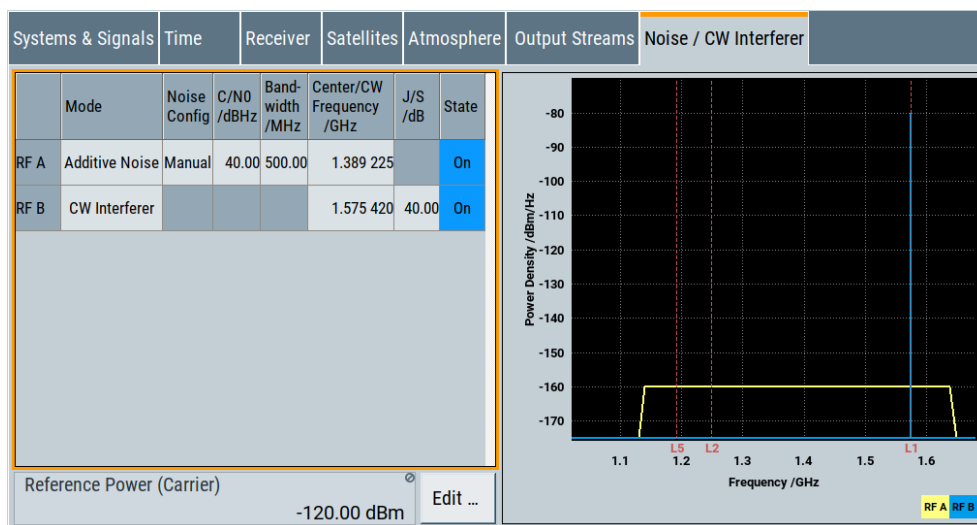

The dialog comprises a table for noise and CW interferer configuration. Also it displays the plotted carrier frequency versus the power density in a graph. The graph also displays the center frequencies of the L1, L2 and L5 bands via red dotted lines.

Also displayed is the noise signal and/or CW interferer signal for both RF paths. Displaying for both paths requires "Number of GNSS Streams ≥ 2". For path "RF A", the signal is labelled yellow. For "RF B", the signal is labelled blue.

3. Add noise or a CW interferer signal in the same way as described in dedicated procedures:
 - "To add noise to a GNSS signal" on page 193
 - "To add a CW interferer to a GNSS signal" on page 195
4. Select "State" > "On" per RF signal path.

Settings:

Noise / Interferer Configuration..... 196

State..... 197

Mode..... 197

Carrier/Noise Density Ratio - C/N₀..... 197

Jammer/Signal Ratio - J/S..... 197

Reference Power (Carrier)..... 197

Noise Config..... 198

 L Edit..... 198

 L Bandwidth..... 198

 L Center Frequency..... 198

CW Frequency..... 198

Noise / Interferer Configuration

Requires "Mode > GNSS Advanced", see "To enable GNSS advanced mode" on page 269.

Provides a table for configuring additive noise and CW interferer signal.

How to: ["To add a noise and/or CW interferer in GNSS advanced mode"](#) on page 195

State

Activates/deactivates the generation of an AWGN signal. The interferer (AWGN or CW interferer, depending on the selected mode) is generated after the generator is activated.

Remote command:

`[:SOURCE<hw>] :BB:GNSS:AWGN [:RF<ch>] :STATE` on page 437

Mode

Activates/deactivates the generation of an AWGN signal. The interferer (AWGN or CW interferer, depending on the selected mode) is generated after the generator is activated.

"Additive Noise"

The AWGN noise signal with selectable system bandwidth is added to the baseband signal.

"CW Interferer" A sine with a defined frequency offset is added to the baseband signal.

Remote command:

`[:SOURCE<hw>] :BB:GNSS:AWGN [:RF<ch>] :MODE` on page 437

Carrier/Noise Density Ratio - C/N₀

Requires "Mode > Additive Noise".

Sets the carrier power to noise power ratio *C/N ratio* that is the difference of carrier power and noise power:

$$C/N \text{ ratio} = \text{carrier power} - \text{noise power}$$

$$\text{Noise power} = \text{Reference power} + 10 * \log_{10}(\text{system bandwidth}) - C/N_0$$

Remote command:

`[:SOURCE<hw>] :BB:GNSS:AWGN [:RF<ch>] :CNDRatio` on page 435

Jammer/Signal Ratio - J/S

Requires "Mode > CW Interferer".

Sets the jammer (interferer) power to signal power ratio *C/I ratio* that is the difference of carrier power and noise power:

$$C/I \text{ ratio} = \text{carrier power} - \text{interferer power}$$

$$\text{Interferer power} = \text{Reference power} + J/S$$

Remote command:

`[:SOURCE<hw>] :BB:GNSS:AWGN [:RF<ch>] :JSRatio` on page 437

Reference Power (Carrier)

Displays the reference power of the GNSS signal.

To edit, click "Edit". The tab "Simulation Configuration > Satellites" opens, where you can set the reference power value. See also ["Reference Power"](#) on page 75.

Remote command:

`[:SOURCE<hw>] :BB:GNSS:POWER:REFERENCE` on page 459

Noise Config

Requires "Mode > Additive Noise".

Defines how noise parameters "Bandwidth" and "Center Frequency" are set.

"Auto" Sets bandwidth and center frequency automatically.

"Edit" Enables configuration of bandwidth and center frequency. Click "Edit" to the right of the selection.

Remote command:

[\[:SOURCE<hw>\]:BB:GNSS:AWGN\[:RF<ch>\]:CONFig](#) on page 435

Edit ← Noise Config

Opens the "Noise Configuration" dialog, where you can configure "Bandwidth" and "Center Frequency".

Bandwidth ← Noise Config

Sets the RF bandwidth to which the set carrier/noise ratio relates.

Within this frequency range, the signal is superimposed with a noise signal which level corresponds exactly to the set C/N or S/N ratio.

Remote command:

[\[:SOURCE<hw>\]:BB:GNSS:AWGN\[:RF<ch>\]:BWIDth](#) on page 435

Center Frequency ← Noise Config

Sets center frequency of the noise signal.

Remote command:

[\[:SOURCE<hw>\]:BB:GNSS:AWGN\[:RF<ch>\]:FREQuency:CENTer](#) on page 436

CW Frequency

Requires "Mode > CW Interferer".

Sets the frequency of the CW interfering signal.

Remote command:

[\[:SOURCE<hw>\]:BB:GNSS:AWGN\[:RF<ch>\]:FREQuency:CW](#) on page 436

13.3 About error sources

You can observe the effect of the following common error sources on the receiver's positioning accuracy:

- Atmospheric (ionospheric and tropospheric) errors
See:
 - [Chapter 13.3.1, "About the atmospheric effects"](#), on page 199.
 - [Chapter 13.4, "Atmospheric effects and ionospheric errors settings"](#), on page 202.
- Difference between the atmospheric condition at the ground station and the receiver, simulated as difference in the simulated ionospheric model and the broadcasted ionospheric parameters in the navigation message
See ["About simulating errors"](#) on page 202

- Additive noise and CW interferer
- Pseudorange errors
See [Chapter 13.5, "Pseudorange errors settings"](#), on page 212.
- Satellite orbit and orbit perturbation errors (ephemeris errors)
See:
 - [Chapter 13.3.2, "About orbit and orbit perturbation parameters and errors"](#), on page 200.
 - [Chapter 13.6, "Orbit and orbit perturbation errors settings"](#), on page 215.
- Satellite clock and time conversion errors, like system time drifts due to difference in the time conversion sets
See:
 - [Chapter 13.3.3, "About clock and time conversion parameters and errors"](#), on page 201.
 - [Chapter 13.8, "Time conversion errors settings"](#), on page 227.

13.3.1 About the atmospheric effects

When traveling through the atmosphere, the satellite signal experiences changes in speed and direction. While the increased travel time due to signal refraction is insignificant, the variation in the signal propagation speed causes pseudorange measurement errors.

Tropospheric effects

The troposphere is the lower atmosphere layer that comprises rain, snow, clouds, etc. and affects the GNSS signals' propagation. GNSS signals experience a variable path delay, caused mainly by the dry atmosphere. The magnitude of this delay depends on the pressure, humidity, temperature and the location of the receiver and the satellite.

Ionospheric effects

The magnitude of ionospheric effects depends on geographical location of the receiver, the hour of day and the solar activity.

Ionospheric effects are frequency-dependent and can be counteracted by frequency measurements. For single frequency receivers, the navigation message contains a set of parameters that describes an ionospheric prediction model with the goal to remove the ionospheric effect.

Tropospheric and ionospheric models

The R&S SMW200A simulates atmospheric effects based on two models, a tropospheric and an ionospheric one. These models define the ionospheric and tropospheric models used to simulate the channel between the satellite and receiver. You can enable and set each of them independently. The selected model applies for all satellites, irrespectively to the GNSS system they belong to.

The provided models differ in terms of complexity. The ionospheric models also assume different approximation of ionospheric effects. For information about the supported models, see:

- "Tropospheric Model" on page 204
- "Ionospheric Model" on page 205

Ionospheric model vs. ionospheric parameters in the navigation message

The ionospheric model defines the satellite to receiver channel, whereas the ionospheric navigation parameters define what the satellites are transmitting (broadcasting) as ionospheric correction parameters.

13.3.2 About orbit and orbit perturbation parameters and errors

The different GNSS systems use specific approach to describe the satellite’s orbit and orbit perturbations.

In GPS, Galileo, BeiDou and QZSS systems, the orbit description is based on the first approximation of 16 Keplerian parameters. The navigation message of a GPS satellite thus carries the reference time of ephemeris t_{0e} , six orbit elements and three rate parameters describing the linear time-dependent changes [1].

Orbit	Clock	Additional Data	Time Conversion for All SVs	Ionosphere for All SVs	
Issue of Data, Ephemeris - IODE	224	Reference Time of Ephemeris - t_{0e}	288 000 s		Orbit
Sqrt. of Semi-major Axis - $A^{1/2}$	5 153.628 906 m $\frac{1}{2}$	Eccentricity - e	0.002 737 999 0		Orbit Perturbation
Inclination Angle - i_0	0.305 935 668 8 semic.	Longitude of Ascending Node - Ω_0	0.018 540 220 3 semic		
Argument of Perigee - ω	0.117 445 588 1 semic.	Mean Anomaly - M_0	0.555 010 156 7 semic.		
Rate of Inclination Angle - i'	0.000 000 000 000 0 semic./s	Rate of Right Ascension - Ω'	-0.000 000 002 5 semic./s		
Mean Motion Difference - Δ_n	0.000 000 000 000 0 semic./s				

Show Scaled Values

Figure 13-1: Satellite orbit (GPS): Understanding the displayed information

- 1 = Issue of data, IODE and reference time, t_{0e}
- 2 = Orbit elements
- 3 = Rate parameters

In GPS, Galileo, BeiDou and QZSS, the perturbations are seen as variations of the orbital elements. In the navigation message, they are described by three pairs of sinusoidal (cosine and sine) corrections C_C and C_S . Each pair describes the difference in latitude C_U , orbital radius C_r and inclination C_i .

GLONASS satellites broadcast their PZ coordinates and velocity at reference epoch time t_b as well as the moon and sun acceleration components [1].

Orbit	Clock	Additional Data	Time Conversion for All SVs
t_b Index	33 300 s	Time of Day - t_b	t_b Interval
X_n	09:15:00	Y_n	09:00:00 - 09:30:00
X'_n		Y'_n	
X''_n		Y''_n	
		Z_n	
		Z'_n	
		Z''_n	

Show Scaled Values

Figure 13-2: Satellite orbit (GLONASS): Understanding the displayed information

- 1 = Reference epoch, t_b ; orbit parameters are given at t_b
- 2 = Coordinates in PZ-90
- 3 = Velocity component
- 4 = Moon and sun acceleration

13.3.3 About clock and time conversion parameters and errors

Clock and time conversion errors

Satellites and receivers can suffer from timing errors. Although satellites are equipped with atomic clocks, there is always a clock offset due to:

- Clock drift between the different SVs.
- Misalignment in the time bases of the different GNSS systems.

The clock in the receiver is usually less precise and is hence prone to an additional drift.

To counteract the drifts in the satellites and GNSS systems time, the navigation message contains satellite clock offset and time conversion parameters, see "[Satellite clock parameters](#)" on page 201.

The receiver clock synchronization errors are estimated and compensated during the positioning measurements, because the receiver clock offset is a constant value present in the measurements of all satellites.

Satellite clock parameters

Satellite clock offset ΔClock_{SV} is described by a second order polynomial given as follows:

$$\Delta\text{Clock}_{SV} = a_{f0} + a_{f1}(t - t_{0c}) + a_{f2}(t - t_{0c})^2, \text{ where:}$$

- t_{0c} is the reference time of clock

- a_{f0} , a_{f1} and a_{f2} are three coefficients that are broadcasted in the navigation message.

Polynomial coefficients

In GPS, Galileo, BeiDou and QZSS, polynomial coefficients are:

- a_{f0} : SV clock offset
- a_{f1} : SV clock drift
- a_{f2} : SV clock drift rate

GLONASS considers the first order version of the polynomial (i.e. $a_{f2} = 0$) and transmits only two clock parameters:

- T_n : SV clock offset, where:
 $a_{f0} = -T_n$
- Γ_n : SV relative frequency offset
 $a_{f1} = \Gamma_n$

13.3.4 Simulating errors

Per default, the broadcasted navigation message parameters per SV are set automatically to match the simulated orbit, clock and pseudorange parameters. For example, the clock parameters in the navigation message of GPS SV ID #1 resemble the simulated clock values for this satellite.

About simulating errors

Errors are deviations between the simulated and broadcasted navigation message parameters. Changing the default navigation message values leads to deviation between the simulated and the broadcasted navigation information and thus deliberate errors. To simulate clock errors, change for example, the parameter a_{f0} in the broadcasted navigation message of SV#1 but maintain the a_{f0} value of the simulated clock.

You can also simulate unusual stations, like, for example, the wrongly broadcasted clock bias between UTC and GPS system clocks. Such situations are simulated by configuring different time conversion sets for the UTC-GPS conversion parameters in the broadcasted navigation message and in the simulated UTC time parameters.

13.4 Atmospheric effects and ionospheric errors settings

Access:

1. Select "Simulation Configuration" > "**Atmosphere**".
2. Set the tropospheric and ionospheric models.
For example, select "Ionospheric Model > NeQuick".

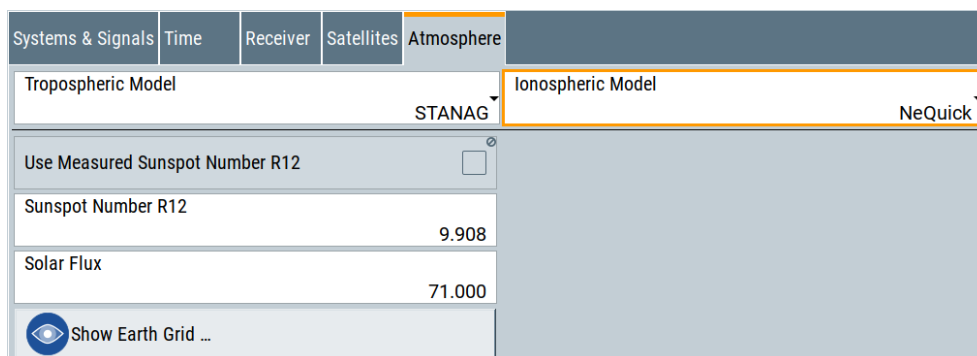

The atmospheric configuration comprises the parameters for adjusting the ionospheric and tropospheric models of the simulation. The selected model describes the actual **ionospheric and tropospheric models used in the satellite-receiver channel simulation**.

3. To configure the ionospheric navigation parameters that define what the satellites are transmitting as **ionospheric correction parameters**, set the ionospheric parameters on the navigation message of the particular GNSS system:
 - a) Select "Simulation Configuration > Satellites > GNSS system > SV# > SV Config > Signals Configuration".
Ionospheric parameters are read-only and common for all SV of one GNSS system. To change them, apply the same configuration to all SVs.
 - b) Select "SV# > SV Config" > "**Copy Modulation Control to SVI-ID = All**".
 - c) Select "**Nav Msg Control > Edit**".
 - d) Select "**Nav Msg Content > Config > Ionosphere**".

Per default, the navigation message parameters are set to fixed values. The values are retrieved from the constellation data source and selected atmospheric model.

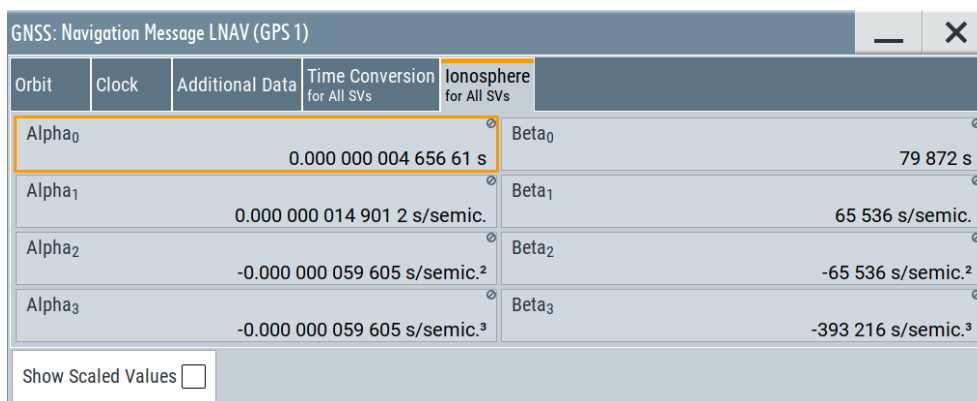

Changing these values leads to deviation between the simulated and the broadcasted navigation message and thus deliberate errors. SBAS corrections can be activated for error compensation.

Available navigation message parameters depend on GNSS system and selected navigation message type.

- The ionospheric model for GLONASS is not yet specified; its satellites transmit no data on the atmosphere.

- GPS, Galileo and BeiDou assume specific ionospheric models. These systems transmit different atmospheric navigation parameters.

For GPS satellites, for example, the navigation message carries the parameters describing the Klobuchar ionospheric model, see [Klobuchar Parameters](#).

Settings:

Atmosphere.....	204
L Tropospheric Model.....	204
L Ionospheric Model.....	205
L Klobuchar Parameters.....	205
L NeQuick Parameters.....	206
L MOPS-DO-229D.....	207
L View Type.....	207
L Import Grid.....	207
L Edit Grid.....	208
L Time Scale, Time Select.....	209
L Insert/Delete Page.....	209
L View Type.....	209
L Longitude, Latitude.....	209
L GIVEI/Vertical Delay.....	209
L Plot Vertical Delays/Plot IGP.....	209
L Export Grid.....	210
L Show Earth Grid.....	210
GPS > Ionosphere.....	210
Galileo > Ionosphere.....	211
BeiDou > Ionosphere.....	211
QZSS > Ionosphere.....	211
NavIC > Ionosphere.....	211
Show Scaled Values.....	212

Atmosphere

Comprises the parameters for adjusting the ionospheric and tropospheric models of the simulation.

The selected model defines the ionospheric and tropospheric models used in the satellite-receiver channel simulation.

See also "[Tropospheric and ionospheric models](#)" on page 199.

Tropospheric Model ← Atmosphere

Sets the tropospheric model used in the satellite-receiver channel simulation.

The troposphere is the lower atmosphere layer that comprises rain, snow, clouds, etc. and affects the GNSS signals propagation. The GNSS signals experience a variable path delay, caused mainly by the dry atmosphere.

"STANAG" A tropospheric model described in the NATO Standard Agreement [STANAG 4294 Issue 1](#).

"MOPS-DO-229D"

The minimum operational performance standard (MOPS) is a tropospheric model used by the SBAS systems.

The model is based on a mapping function or wet and dry troposphere.

Remote command:

[:SOURCE<hw>] :BB:GNSS:ATMospheric:TROPospheric:MODe1 on page 430

Ionospheric Model ← Atmosphere

Sets ionospheric model used by the channel simulation.

The selected model applies for all satellites, irrespectively to the navigation standards they belong to.

"Klobuchar"

Klobuchar is the correction model used by GPS.

Although the Klobuchar algorithm estimates the ionospheric delay in the GPS L1 frequency signal, it can be also used for delay estimations for any GNSS signal.

See "Klobuchar Parameters" on page 205.

"NeQuick"

NeQuick is the correction model proposed by Galileo, but the ionospheric corrections computed by the NeQuick can be used for any GNSS signal.

NeQuick is a 3D time-dependent ionospheric electron density model. It provides electron density in the ionosphere as a function of the position (longitude, latitude and height), time (UTC or TOW) and the solar activity. [1]

See "NeQuick Parameters" on page 206.

"MOPS-DO-229D"

The minimum operational performance standard (MOPS) is a model used by the SBAS systems and based on a mapping function or wet and dry troposphere.

See "MOPS-DO-229D" on page 207.

Remote command:

[:SOURCE<hw>] :BB:GNSS:ATMospheric:IONospheric:MODe1 on page 430

Klobuchar Parameters ← Atmosphere

Systems & Signals	Time	Receiver	Satellites	Atmosphere	
Tropospheric Model				STANAG	Ionospheric Model
					Klobuchar
Alpha ₀	0.000 000 004 656 61 s			Beta ₀	79 872 s
Alpha ₁	0.000 000 014 901 2 s/semic.			Beta ₁	65 536 s/semic.
Alpha ₂	-0.000 000 059 605 s/semic. ²			Beta ₂	-65 536 s/semic. ²
Alpha ₃	-0.000 000 059 605 s/semic. ³			Beta ₃	-393 216 s/semic. ³
 Show Earth Grid ...					

The Klobuchar model assumes that the vertical delays are constant values at night time and follow a half-cosine function in daytime, see Figure 13-3.

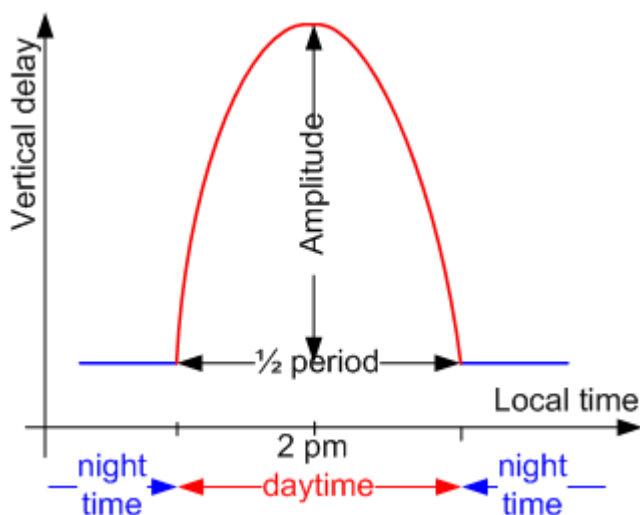

Figure 13-3: Klobuchar ionospheric model

The amplitude and the period of this function depend on the receiver location and are calculated from the eight broadcast coefficients "alpha_0 to alpha_3" and "beta_0 to beta_3". These coefficients are included in the navigation message of the simulated satellites.

Remote command:

[:SOURCE<hw>] :BB:GNSS:ATMospheric:IONospheric:KLOBuchar:ALPHA<ch0>:UNSCaled on page 433

[:SOURCE<hw>] :BB:GNSS:ATMospheric:IONospheric:KLOBuchar:BETA<ch0>:UNSCaled on page 434

NeQuick Parameters ← Atmosphere

Systems & Signals	Time	Receiver	Satellites	Atmosphere	
Tropospheric Model				STANAG	Ionospheric Model
Use Measured Sunspot Number R12				<input type="checkbox"/>	NeQuick
Sunspot Number R12				9.908	
Solar Flux				71.000	
Show Earth Grid ...					

The NeQuick model provides electron density in the ionosphere as a function of the position (longitude, latitude and height), time (UTC or TOW) and the solar activity.

It is based on the original profiler proposed by Di Giovanni and Radicella, 1990. The NeQuick FORTRAN 77 code is available for download at the [website of the International Telecommunication Union Radiocommunication Sector \(ITU-R\)](#).

The solar activity is defined with *one* of the following parameters:

- "Solar Flux"
Flux level generated by the sun at the earth's orbit at a 10.7 cm wavelength (F10.7)
- "Sunspot Number R12"
Averaged sunspot number R12.
You can set the R12 value or, if the "Simulation Time" is within the period from year 1931 to year 2001, use real R12 values.
("Use Measured Sunspot Number R12 > On").

Remote command:

`[:SOURCE<hw>] :BB:GNSS:ATMospheric:IONospheric:NEQuick:SFLux`
on page 430

`[:SOURCE<hw>] :BB:GNSS:ATMospheric:IONospheric:NEQuick:UMSN`
on page 431

`[:SOURCE<hw>] :BB:GNSS:ATMospheric:IONospheric:NEQuick:SUNSpot`
on page 430

MOPS-DO-229D ← Atmosphere

The simulation of ionospheric delays follows the pierce point interpolation technique described in the [RTCA MOPS DO-229](#).

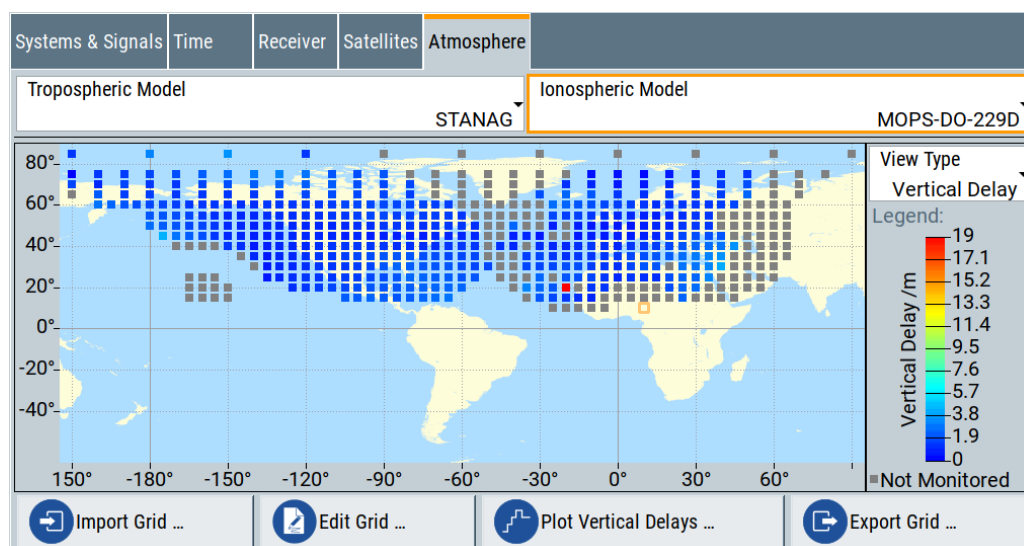

Remote command:

`[:SOURCE<hw>] :BB:GNSS:ATMospheric:IONospheric:MOPS:FILE`
on page 431

View Type ← MOPS-DO-229D ← Atmosphere

Toggles between indication of the vertical delay and GIVEI values.

Remote command:

`[:SOURCE<hw>] :BB:GNSS:ATMospheric:IONospheric:MOPS:DISPlay`
on page 431

Import Grid ← MOPS-DO-229D ← Atmosphere

Access: Select "Import Grid > Add File/Add Directory > select the files > Import".

Accesses the standard file import dialog for loading predefined and user-defined SBAS files or ionospheric grid files (*.iono_grid). The ionospheric grid information is replaced at once.

If more than one file is selected, the ionospheric grid information is aggregated. Combining ionospheric grids allows you to create an ionospheric grid covering the entire world map.

Provided functions are self-explanatory; for details, see [Example "Importing grid files"](#) on page 428.

Remote command:

[:SOURCE<hw>] :BB:GNSS:ATMospheric:IONospheric:MOPS:IMPort:ADD:FILE:EMS on page 432

[:SOURCE<hw>] :BB:GNSS:ATMospheric:IONospheric:MOPS:IMPort:ADD:FILE:GRID on page 432

[:SOURCE<hw>] :BB:GNSS:ATMospheric:IONospheric:MOPS:IMPort:ADD:FILE:NSTB on page 432

[:SOURCE<hw>] :BB:GNSS:ATMospheric:IONospheric:MOPS:IMPort:ADD:DIR on page 432

[:SOURCE<hw>] :BB:GNSS:ATMospheric:IONospheric:MOPS:IMPort:LIST? on page 433

[:SOURCE<hw>] :BB:GNSS:ATMospheric:IONospheric:MOPS:IMPort:EXECute on page 433

[:SOURCE<hw>] :BB:GNSS:ATMospheric:IONospheric:MOPS:IMPort:REMOve:ALL on page 433

[:SOURCE<hw>] :BB:GNSS:ATMospheric:IONospheric:MOPS:IMPort:REMOve:FILE<ch> on page 433

Edit Grid ← MOPS-DO-229D ← Atmosphere

Changes the ionospheric vertical delay and GIVEI values for a particular position on the map.

Changes are applied immediately.

To save the ionospheric grid, select "Export Grid".

To restore the predefined ionospheric grid for the MOPS-DO-229 model, select "Import Grid > Add File > Predefined Files > 19_02_14_mixed > Import".

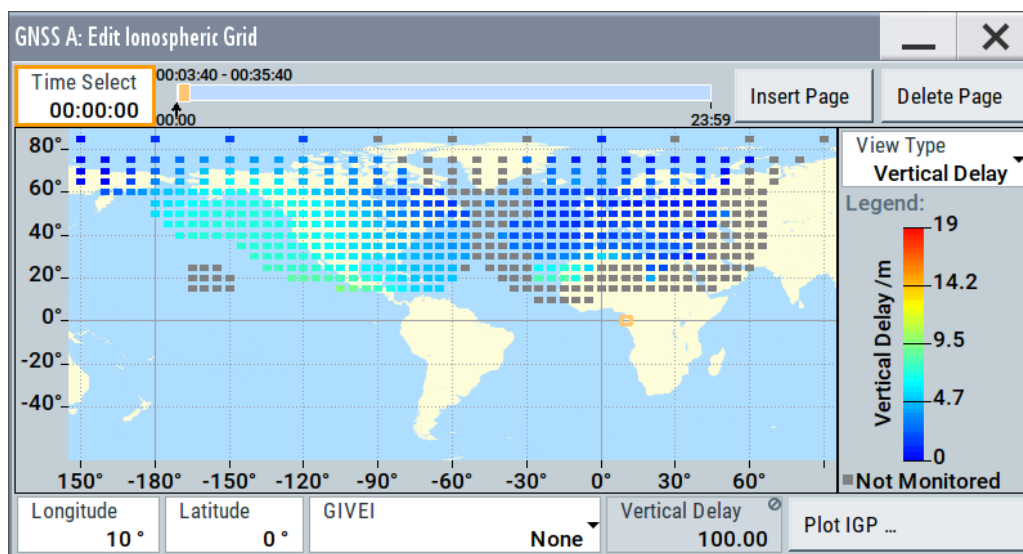

Time Scale, Time Select ← Edit Grid ← MOPS-DO-229D ← Atmosphere

Displays a time scale (the gray bar) and the current time span (the orange bar).

An arrow indicates the current time ("Time Select").

Projection mechanism ensures that you can select any simulation date. Hence, date information is irrelevant and not displayed.

Insert/Delete Page ← Edit Grid ← MOPS-DO-229D ← Atmosphere

"Insert Page" splits the current page at the current "Time Select" moment.

"Delete Page" removes the current page; the time span of the previous page is extended and the content of the new page corresponds to the content of the previous page.

View Type ← Edit Grid ← MOPS-DO-229D ← Atmosphere

Toggles between indication of the vertical delay and GIVEI values.

Remote command:

`[:SOURCE<hw>] :BB:GNSS:ATMospheric:IONospheric:MOPS:DISPlay`
on page 431

Longitude, Latitude ← Edit Grid ← MOPS-DO-229D ← Atmosphere

Indicates the geographic coordinated of the selected ionospheric grid point IGP.

GIVEI/Vertical Delay ← Edit Grid ← MOPS-DO-229D ← Atmosphere

Sets the grid ionospheric vertical error indicator "GIVEI" and the "Vertical Delay" values of the current IGP.

Changes are applied immediately.

To save the ionospheric grid, select "Export Grid".

To restore the predefined ionospheric grid for the MOPS-DO-229 model, select "Import Grid > Add File > Predefined Files > 19_02_14_mixed > Import".

Plot Vertical Delays/Plot IGP ← MOPS-DO-229D ← Atmosphere

Displays the 24h vertical delay or GIVEI distribution functions.

Access: select a particular position on the "Ionospheric Grid" map and select "Plot IGP".

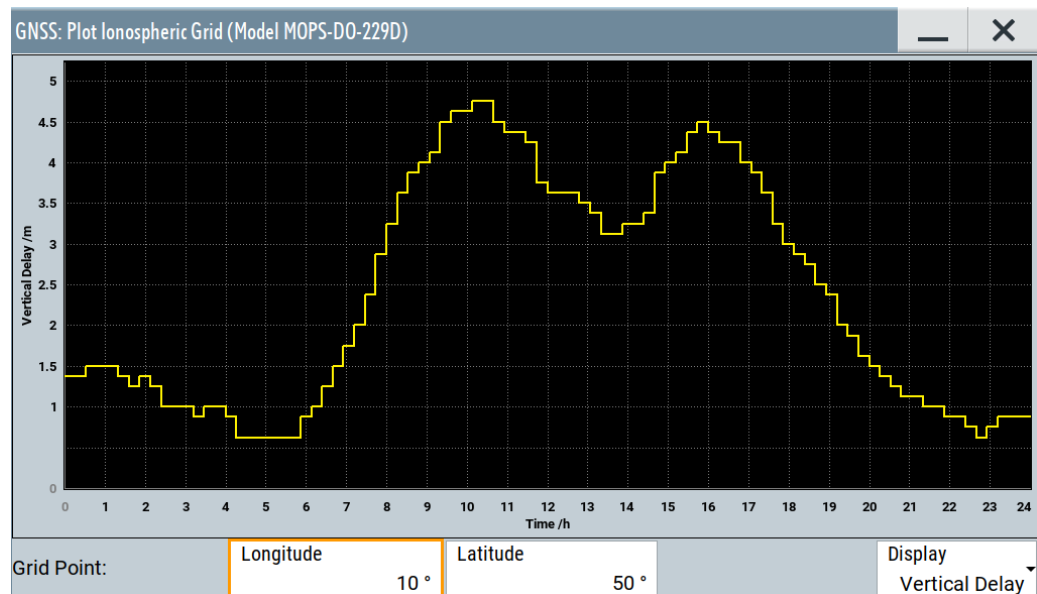

Figure 13-4: Example: 24h vertical delay distribution for a given position (the curve shows the MOPS-DO-229D distribution)

"Longitude, Latitude"

Scrolls between the grid points.

"Display"

Toggles between indication of the vertical delay and GIVEI values. The plot displays the variation of these values over a 24-hour time period.

Export Grid ← MOPS-DO-229D ← Atmosphere

Access: select "Export Grid > set the filename > Export".

Standard dialog for file handling; provided functions are self-explanatory. Filename is user-definable, file extension *.iono_grid is assigned automatically.

Use this function to save current ionospheric grid. Files created in this way can be reloaded with the [Import Grid](#) function.

Remote command:

```
[ :SOURCE<hw> ] :BB:GNSS:ATMospheric:IONospheric:MOPS:EXPort
```

on page 432

Show Earth Grid ← Atmosphere

Requires "Ionospheric Model > Klobuchar/NeQuick".

Accesses the dialog that displays the earth grid for ionospheric models Klobuchar or NeQuick.

GPS > Ionosphere

Comprises the parameters of the GPS satellites.

Table 13-1: LNAV and CNAV

Parameter	Remote command:
"Alpha ₀ " to "Alpha ₃ "	<code>[:SOURCE<hw>] :BB:GNSS:ATMOSPHERIC:GPS:NMESsage:LNAV:IONOSPHERIC:ALPHA<ch0></code> on page 564
"Beta ₀ " to "Beta ₃ "	<code>[:SOURCE<hw>] :BB:GNSS:ATMOSPHERIC:GPS:NMESsage:LNAV:IONOSPHERIC:BETA<ch0></code> on page 565

Galileo > Ionosphere

Comprises the parameters of the Galileo satellites.

Table 13-2: INAV and FNAV

Parameter	Remote command:
"a ₀ " to "a ₁₂ "	<code>[:SOURCE<hw>] :BB:GNSS:ATMOSPHERIC:GALILEO:NMESsage:INAV:IONOSPHERIC:AI<ch0></code> on page 564
"SF ₁ " to "SF ₅ "	<code>[:SOURCE<hw>] :BB:GNSS:ATMOSPHERIC:GALILEO:NMESsage:INAV:IONOSPHERIC:SF<ch></code> on page 566

BeiDou > Ionosphere

Comprises the parameters of the BeiDou satellites.

Table 13-3: DNAV and CNAV

Parameter	Remote command:
"Alpha ₀ - Alpha ₃ "	<code>[:SOURCE<hw>] :BB:GNSS:ATMOSPHERIC:BEIDOU:NMESsage:DNAV:IONOSPHERIC:ALPHA<ch0></code> on page 564
"Beta ₀ - Beta ₃ "	<code>[:SOURCE<hw>] :BB:GNSS:ATMOSPHERIC:BEIDOU:NMESsage:DNAV:IONOSPHERIC:BETA<ch0></code> on page 565

QZSS > Ionosphere

Comprises the parameters of the QZSS satellites.

Table 13-4: NAV and CNAV

Parameter	Remote command:
"Alpha ₀ " to "Alpha ₃ "	<code>[:SOURCE<hw>] :BB:GNSS:ATMOSPHERIC:QZSS:NMESsage:NAV:IONOSPHERIC:ALPHA<ch0></code> on page 564
"Beta ₀ " to "Beta ₃ "	<code>[:SOURCE<hw>] :BB:GNSS:ATMOSPHERIC:QZSS:NMESsage:NAV:IONOSPHERIC:BETA<ch0></code> on page 565

NavIC > Ionosphere

Comprises the parameters of the NavIC satellites.

Parameter	Remote command:
"Alpha ₀ " to "Alpha ₃ "	<code>[:SOURCE<hw>] :BB:GNSS:ATMOSPHERIC:NAVIC:NMESsage:NAV:IONOSPHERIC:ALPHA<ch0></code> on page 564
"Beta ₀ " to "Beta ₃ "	<code>[:SOURCE<hw>] :BB:GNSS:ATMOSPHERIC:NAVIC:NMESsage:NAV:IONOSPHERIC:BETA<ch0></code> on page 565

Show Scaled Values

Switches between scaled and unscaled values representation.

Navigation message values are recalculated automatically.

Remote command:

[:SOURce<hw>] :BB:GNSS:SSValues on page 483

13.5 Pseudorange errors settings

Access:

1. Select "Simulation Configuration > Satellites".
2. Select the GNSS system for that you want to configure satellites constellation, for example GPS.
3. Select "SV# > SV Config".
4. In the "SV Configuration" dialog, select "**Pseudorange Errors**".
5. Select, for example, "Error Mode > Profile".
6. Define the errors in the table.

For "Error Mode = Profile or Constant", a pseudorange error plot indicates the error variation over time.



Settings

Error Mode..... 213

Copy to,SV-ID..... 213

Value..... 213

Start Time Offset.....	213
Pseudorange Errors File.....	214
Profile Table.....	214

Error Mode

Defines how the pseudorange errors are specified:

"Constant"	Applied is the constant pseudorange error set with the parameter Value .
"Profile"	The pseudorange errors are defined in table form, see "Profile Table" on page 214.
"From SBAS"	If "Simulation Configuration > Satellites > SBAS > Error Correction Mode > Real Historical data and Sync Atmosphere & SVs Errors", pseudorange errors are extracted from the imported SBAS correction files. All other pseudorange error modes are disabled.
"File"	Loads pseudorange error information from a file with extension <code>*.rs_perr</code> . To load a file, click "Pseudorange Errors File" and select the file from the standard "File Select" dialog.

Remote command:

`[:SOURCE<hw>] :BB:GNSS:SVID<ch>:GPS:PREErrors:MODE` on page 493
(etc. for the other GNSS systems)

Copy to,SV-ID

Applies the pseudorange errors of the current satellite to selected or to all SV-IDs.

Remote command:

`[:SOURCE<hw>] :BB:GNSS:SVID<ch>:GPS:PREErrors:COPY:SVID` on page 494
`[:SOURCE<hw>] :BB:GNSS:SVID<ch>:GPS:PREErrors:COPY:EXECute`
on page 495
(etc. for the other GNSS systems)

Value

Sets a constant pseudorange error value.

Remote command:

`[:SOURCE<hw>] :BB:GNSS:SVID<ch>:GPS:PREErrors:VALue` on page 496
(etc. for the other GNSS systems)

Start Time Offset

Applies a delay and shifts the pseudorange error profile in time, for example to allow the receiver under test to calculate a position fix. Suitable start time offsets are then longer than the TTFF time.

"Start Time Offset = 0" corresponds to the simulation start time, as defined with the parameter [Simulation Start](#).

Observe the pseudorange error plot.

Remote command:

`[:SOURCE<hw>] :BB:GNSS:SVID<ch>:GPS:PRERrors:PROFile:OFFSet`

on page 496

(etc. for the other GNSS systems)

Pseudorange Errors File

Requires "Error Mode > File".

Accesses a standard "File Select" dialog to select pseudorange error files with extension `*.rs_perr`.

Remote command:

`[:SOURCE<hw>] :BB:GNSS:PERRors:CATalog` on page 493

`[:SOURCE<hw>] :BB:GNSS:SVID<ch>:GPS:PRERrors:FILE` on page 494

(etc. for the other GNSS systems)

Profile Table

A pseudorange error profile is described as a sequence of up to 10 errors defined in table form.

"Time" Reference time of the error.
The value is set relative to the sum of the simulation start time and the [Start Time Offset](#).

Remote command:

`[:SOURCE<hw>] :BB:GNSS:SVID<ch>:GPS:PRERrors:PROFile<gr>:REFeRence` on page 498

(etc. for the other GNSS systems)

"Value" A positive or negative pseudorange error.
The last "Value" is repeated constantly.

Remote command:

`[:SOURCE<hw>] :BB:GNSS:SVID<ch>:GPS:PRERrors:PROFile<gr>:VALue` on page 498

(etc. for the other GNSS systems)

"Insert" Inserts a row above the selected one.

Remote command:

`[:SOURCE<hw>] :BB:GNSS:SVID<ch>:GPS:PRERrors:PROFile<gr>:INSert` on page 499

(etc. for the other GNSS systems)

"Delete" Removes the selected row.

Remote command:

`[:SOURCE<hw>] :BB:GNSS:SVID<ch>:GPS:PRERrors:PROFile<gr>:DELeTe` on page 499

(etc. for the other GNSS systems)

Remote command:

`[:SOURCE<hw>] :BB:GNSS:SVID<ch>:GPS:PRERrors:PROFile:COUNT?` on page 497

`[:SOURCE<hw>] :BB:GNSS:SVID<ch>:GPS:PRERrors:PROFile:APPend` on page 497

(etc. for the other GNSS systems)

13.6 Orbit and orbit perturbation errors settings

Access:

1. Select "Simulation Configuration > Satellites".
2. Select the GNSS system for that you want simulate system errors, for example GPS.
3. Select "SV# > SV Config > Signals Configuration".
4. Select real navigation data as data source.
For example, for a GPS SV ID, select "Nav Msg Type > LNAV".
5. Select "Nav Msg Control > Edit".
6. Select "Nav Msg Content > Config > Orbit".

Per default, the navigation message parameters are set to values corresponding to the values retrieved from the constellation data source.

Orbit	Clock	Additional Data	Time Conversion for All SVs	Ionosphere for All SVs	
Issue of Data, Ephemeris - IODE			224		Reference Time of Ephemeris - t_{0e} 288 000 s
Sqrt. of Semi-major Axis - $A^{1/2}$			5 153.628 906 m ^{1/2}		Eccentricity - e 0.002 737 999 0
Inclination Angle - i_0			0.305 935 668 8 semic.		Longitude of Ascending Node - Ω_0 0.018 540 220 3 semic
Argument of Perigee - ω			0.117 445 588 1 semic.		Mean Anomaly - M_0 0.555 010 156 7 semic.
Rate of Inclination Angle - i'			0.000 000 000 000 0 semic./s		Rate of Right Ascension - Ω' -0.000 000 002 5 semic./s
Mean Motion Difference - Δ_n			0.000 000 000 000 0 semic./s		

Show Scaled Values

Figure 13-5: Satellite orbit: Understanding the displayed information

- 1 = Issue of data, IODE and reference time, t_{0e}
 2 = Orbit elements
 3 = Rate parameters

Changing these values leads to deviation between the simulated and the broadcasted navigation message and thus deliberate errors. The generated signal can be used for testing the receiver's ability to cope with errors. SBAS corrections can be activated for error compensation.

Available navigation message parameters depend on GNSS system and selected navigation message type, see [Chapter 13.3.2, "About orbit and orbit perturbation parameters and errors"](#), on page 200.

Settings

GPS > Orbit.....	216
GPS > Orbit Perturbation.....	217
Galileo > Orbit.....	217
Galileo > Orbit Perturbation.....	218
GLONASS > Orbit.....	218
BeiDou > Orbit.....	219
BeiDou > Orbit Perturbation.....	220
QZSS > Orbit.....	220
QZSS > Orbit Perturbation.....	221
NavIC > Orbit.....	222
NavIC > Orbit Perturbation.....	222
Show Scaled Values.....	223

GPS > Orbit

Comprises the orbit parameters of the GPS satellites.

Table 13-5: LNAV and CNAV

Parameter	Remote command:
"Reference Time of Ephemeris - t_{0e} "	[:SOURCE<hw>] :BB:GNSS:SVID<ch>:GPS:NMESsage: LNAV:EPHemeris:TOE on page 522
"Square Root of Semi-Major Axis - $A^{1/2}$ "	[:SOURCE<hw>] :BB:GNSS:SVID<ch>:GPS:NMESsage: LNAV:EPHemeris:SQRA on page 523
"Eccentricity - e"	[:SOURCE<hw>] :BB:GNSS:SVID<ch>:GPS:NMESsage: LNAV:EPHemeris:ECCentricity on page 524
"Inclination Angle - i_0 "	[:SOURCE<hw>] :BB:GNSS:SVID<ch>:GPS:NMESsage: LNAV:EPHemeris:IZERo on page 525
"Longitude of Ascending Node - Ω_0 "	[:SOURCE<hw>] :BB:GNSS:SVID<ch>:GPS:NMESsage: LNAV:EPHemeris:OZERo on page 525
"Argument of Perigee - ω "	[:SOURCE<hw>] :BB:GNSS:SVID<ch>:GPS:NMESsage: LNAV:EPHemeris:OMEGa on page 526
"Mean Anomaly - M_0 "	[:SOURCE<hw>] :BB:GNSS:SVID<ch>:GPS:NMESsage: LNAV:EPHemeris:MZERo on page 527
"Rate of Inclination Angle - i'' "	[:SOURCE<hw>] :BB:GNSS:SVID<ch>:GPS:NMESsage: LNAV:EPHemeris:IDOT on page 528
"Rate of Right Ascension - Ω'' "	[:SOURCE<hw>] :BB:GNSS:SVID<ch>:GPS:NMESsage: LNAV:EPHemeris:ODOT on page 529

Table 13-6: LNAV

Parameter	Remote command:
"Issue of Data, Ephemeris - IODE"	[:SOURCE<hw>] :BB:GNSS:SVID<ch>:GPS:NMESsage: LNAV:EPHemeris:IODE on page 521
"Mean Motion Difference - Δ_n "	[:SOURCE<hw>] :BB:GNSS:SVID<ch>:GPS:NMESsage: LNAV:EPHemeris:NDELta on page 530

Table 13-7: CNAV

Parameter	Remote command:
"Rate of Right Ascension Diff. - $\Delta\Omega$ "	[:SOURCE<hw>] :BB:GNSS:SVID<ch>:GPS:NMESSsage:CNAV:EPHemeris:DODot on page 529
"Mean Motion Difference - Δ_{n0} "	[:SOURCE<hw>] :BB:GNSS:SVID<ch>:GPS:NMESSsage:CNAV:EPHemeris:NDELta on page 530
"Rate of Mean Motion Diff. - Δ_{n0} "	[:SOURCE<hw>] :BB:GNSS:SVID<ch>:GPS:NMESSsage:CNAV:EPHemeris:DNDot on page 531
"Change Rate in Semi-major Axis - A"	[:SOURCE<hw>] :BB:GNSS:SVID<ch>:GPS:NMESSsage:CNAV:EPHemeris:ADOT on page 531
"Semi-Major Axis Difference - ΔA "	[:SOURCE<hw>] :BB:GNSS:SVID<ch>:GPS:NMESSsage:CNAV:EPHemeris:ADELta on page 531

GPS > Orbit Perturbation

Comprises the parameters of the GPS satellites.

Table 13-8: LNAV and CNAV

Parameter	Remote command:
"Cosine Difference of Latitude - C_{uc} "	[:SOURCE<hw>] :BB:GNSS:SVID<ch>:GPS:NMESSsage:LNAV:EPHemeris:CUC on page 535
"Sine Difference of Latitude - C_{us} "	[:SOURCE<hw>] :BB:GNSS:SVID<ch>:GPS:NMESSsage:LNAV:EPHemeris:CUS on page 536
"Cosine Difference of Orbital Radius - C_{rc} "	[:SOURCE<hw>] :BB:GNSS:SVID<ch>:GPS:NMESSsage:LNAV:EPHemeris:CRC on page 537
"Sine Difference of Orbital Radius - C_{rs} "	[:SOURCE<hw>] :BB:GNSS:SVID<ch>:GPS:NMESSsage:LNAV:EPHemeris:CRS on page 538
"Cosine Difference of Inclination - C_{ic} "	[:SOURCE<hw>] :BB:GNSS:SVID<ch>:GPS:NMESSsage:LNAV:EPHemeris:CIC on page 538
"Sine Difference of Inclination - C_{is} "	[:SOURCE<hw>] :BB:GNSS:SVID<ch>:GPS:NMESSsage:LNAV:EPHemeris:CIS on page 539

Galileo > Orbit

Comprises the parameters of the Galileo satellites.

Table 13-9: INAV and FNAV

Parameter	Remote command:
"IODnav"	[:SOURCE<hw>] :BB:GNSS:SVID<ch>:GALileo:NMESSsage:INAV:EPHemeris:IODNav on page 521
"Reference Time of Ephemeris - t_{0e} "	[:SOURCE<hw>] :BB:GNSS:SVID<ch>:GALileo:NMESSsage:INAV:EPHemeris:TOE on page 522
"Square Root of Semi-Major Axis - $A^{1/2}$ "	[:SOURCE<hw>] :BB:GNSS:SVID<ch>:GALileo:NMESSsage:INAV:EPHemeris:SQRA on page 522
"Eccentricity - e"	[:SOURCE<hw>] :BB:GNSS:SVID<ch>:GALileo:NMESSsage:INAV:EPHemeris:ECCentricity on page 523

Parameter	Remote command:
"Inclination Angle - i_0 "	<code>[:SOURCE<hw>] :BB:GNSS:SVID<ch>:GALileo:NMESsage:INAV:EPHemeris:IZERo</code> on page 524
"Longitude of Ascending Node - Ω_0 "	<code>[:SOURCE<hw>] :BB:GNSS:SVID<ch>:GALileo:NMESsage:INAV:EPHemeris:OZERo</code> on page 525
"Argument of Perigee - ω "	<code>[:SOURCE<hw>] :BB:GNSS:SVID<ch>:GALileo:NMESsage:INAV:EPHemeris:OMEGa</code> on page 526
"Mean Anomaly - M_0 "	<code>[:SOURCE<hw>] :BB:GNSS:SVID<ch>:GALileo:NMESsage:INAV:EPHemeris:MZERo</code> on page 527
"Rate of Inclination Angle - i'' "	<code>[:SOURCE<hw>] :BB:GNSS:SVID<ch>:GALileo:NMESsage:INAV:EPHemeris:IDOT</code> on page 528
"Rate of Right Ascension - Ω'' "	<code>[:SOURCE<hw>] :BB:GNSS:SVID<ch>:GALileo:NMESsage:INAV:EPHemeris:ODOT</code> on page 529
"Mean Motion Difference - Δ_n "	<code>[:SOURCE<hw>] :BB:GNSS:SVID<ch>:GALileo:NMESsage:INAV:EPHemeris:NDELta</code> on page 530

Galileo > Orbit Perturbation

Comprises the parameters of the Galileo satellites.

Table 13-10: INAV and FNAV

Parameter	Remote command:
"Cosine Difference of Latitude - C_{uc} "	<code>[:SOURCE<hw>] :BB:GNSS:SVID<ch>:GALileo:NMESsage:INAV:EPHemeris:CUC</code> on page 535
"Sine Difference of Latitude - C_{us} "	<code>[:SOURCE<hw>] :BB:GNSS:SVID<ch>:GALileo:NMESsage:INAV:EPHemeris:CUS</code> on page 535
"Cosine Difference of Orbital Radius - C_{rc} "	<code>[:SOURCE<hw>] :BB:GNSS:SVID<ch>:GALileo:NMESsage:INAV:EPHemeris:CRC</code> on page 536
"Sine Difference of Orbital Radius - C_{rs} "	<code>[:SOURCE<hw>] :BB:GNSS:SVID<ch>:GALileo:NMESsage:INAV:EPHemeris:CRS</code> on page 537
"Cosine Difference of Inclination - C_{ic} "	<code>[:SOURCE<hw>] :BB:GNSS:SVID<ch>:GALileo:NMESsage:INAV:EPHemeris:CIC</code> on page 538
"Sine Difference of Inclination - C_{is} "	<code>[:SOURCE<hw>] :BB:GNSS:SVID<ch>:GALileo:NMESsage:INAV:EPHemeris:CIS</code> on page 539

GLONASS > Orbit

Comprises the parameters of the GLONASS satellites.

See also [Chapter 13.3.2, "About orbit and orbit perturbation parameters and errors"](#), on page 200.

Orbit and orbit perturbation errors settings

Parameter	Remote command:
" t_b Index"	[:SOURCE<hw>] :BB:GNSS:SVID<ch>:GLONASS:NMESsage:NAV:EPHemeris:TINDEX on page 532
"Time of Day - t_b / t_b Interval"	[:SOURCE<hw>] :BB:GNSS:SVID<ch>:GLONASS:NMESsage:NAV:EPHemeris:TOE? on page 532 [:SOURCE<hw>] :BB:GNSS:SVID<ch>:GLONASS:NMESsage:NAV:EPHemeris:TINTERVAL? on page 532
" X_n "	[:SOURCE<hw>] :BB:GNSS:SVID<ch>:GLONASS:NMESsage:NAV:EPHemeris:ZN on page 533
" Y_n "	[:SOURCE<hw>] :BB:GNSS:SVID<ch>:GLONASS:NMESsage:NAV:EPHemeris:YN on page 533
" Z_n "	[:SOURCE<hw>] :BB:GNSS:SVID<ch>:GLONASS:NMESsage:NAV:EPHemeris:ZN on page 533
" X'_n "	[:SOURCE<hw>] :BB:GNSS:SVID<ch>:GLONASS:NMESsage:NAV:EPHemeris:XDN on page 533
" Y'_n "	[:SOURCE<hw>] :BB:GNSS:SVID<ch>:GLONASS:NMESsage:NAV:EPHemeris:YDN on page 533
" Z'_n "	[:SOURCE<hw>] :BB:GNSS:SVID<ch>:GLONASS:NMESsage:NAV:EPHemeris:ZDN on page 533
" X''_n "	[:SOURCE<hw>] :BB:GNSS:SVID<ch>:GLONASS:NMESsage:NAV:EPHemeris:XDDN on page 534
" Y''_n "	[:SOURCE<hw>] :BB:GNSS:SVID<ch>:GLONASS:NMESsage:NAV:EPHemeris:YDDN on page 534
" Z''_n "	[:SOURCE<hw>] :BB:GNSS:SVID<ch>:GLONASS:NMESsage:NAV:EPHemeris:ZDDN on page 534

BeiDou > Orbit

Comprises the parameters of the BeiDou satellites.

Table 13-11: DNAV and CNAV

Parameter	Remote command:
"AODE"	[:SOURCE<hw>] :BB:GNSS:SVID<ch>:BEIDOU:NMESsage:DNAV:EPHemeris:IODE on page 521
"Reference Time of Ephemeris - t_{0e} "	[:SOURCE<hw>] :BB:GNSS:SVID<ch>:BEIDOU:NMESsage:DNAV:EPHemeris:TOE on page 522
"Square Root of Semi-Major Axis - $A^{1/2}$ "	[:SOURCE<hw>] :BB:GNSS:SVID<ch>:BEIDOU:NMESsage:DNAV:EPHemeris:SQRA on page 523
"Eccentricity - e"	[:SOURCE<hw>] :BB:GNSS:SVID<ch>:BEIDOU:NMESsage:DNAV:EPHemeris:ECCENTRICITY on page 523
"Inclination Angle - i_0 "	[:SOURCE<hw>] :BB:GNSS:SVID<ch>:BEIDOU:NMESsage:DNAV:EPHemeris:IZERO on page 524
"Longitude of Ascending Node - Ω_0 "	[:SOURCE<hw>] :BB:GNSS:SVID<ch>:BEIDOU:NMESsage:DNAV:EPHemeris:OZERO on page 525

Orbit and orbit perturbation errors settings

Parameter	Remote command:
"Argument of Perigee - ω "	[:SOURCE<hw>] :BB:GNSS:SVID<ch>:BEIDou:NMESsage:DNAV:EPHemeris:OMEGa on page 526
"Mean Anomaly - M_0 "	[:SOURCE<hw>] :BB:GNSS:SVID<ch>:BEIDou:NMESsage:DNAV:EPHemeris:MZERo on page 527
"Rate of Inclination Angle - i'' "	[:SOURCE<hw>] :BB:GNSS:SVID<ch>:BEIDou:NMESsage:DNAV:EPHemeris:IDOT on page 528
"Rate of Right Ascension - Ω'' "	[:SOURCE<hw>] :BB:GNSS:SVID<ch>:BEIDou:NMESsage:DNAV:EPHemeris:ODOT on page 529
"Mean Motion Difference - Δ_n "	[:SOURCE<hw>] :BB:GNSS:SVID<ch>:BEIDou:NMESsage:DNAV:EPHemeris:NDELta on page 530

BeiDou > Orbit Perturbation

Comprises the parameters of the BeiDou satellites.

Table 13-12: DNAV and CNAV

Parameter	Remote command:
"Cosine Difference of Latitude - C_{uc} "	[:SOURCE<hw>] :BB:GNSS:SVID<ch>:BEIDou:NMESsage:DNAV:EPHemeris:CUC on page 535
"Sine Difference of Latitude - C_{us} "	[:SOURCE<hw>] :BB:GNSS:SVID<ch>:BEIDou:NMESsage:DNAV:EPHemeris:CUS on page 536
"Cosine Difference of Orbital Radius - C_{rc} "	[:SOURCE<hw>] :BB:GNSS:SVID<ch>:BEIDou:NMESsage:DNAV:EPHemeris:CRc on page 536
"Sine Difference of Orbital Radius - C_{rs} "	[:SOURCE<hw>] :BB:GNSS:SVID<ch>:BEIDou:NMESsage:DNAV:EPHemeris:CRS on page 537
"Cosine Difference of Inclination - C_{ic} "	[:SOURCE<hw>] :BB:GNSS:SVID<ch>:BEIDou:NMESsage:DNAV:EPHemeris:CIC on page 538
"Sine Difference of Inclination - C_{is} "	[:SOURCE<hw>] :BB:GNSS:SVID<ch>:BEIDou:NMESsage:DNAV:EPHemeris:CIS on page 539

QZSS > Orbit

Comprises the parameters of the QZSS satellites.

Table 13-13: LNAV and CNAV

Parameter	Remote command:
"Reference Time of Ephemeris - t_{0e} "	[:SOURCE<hw>] :BB:GNSS:SVID<ch>:QZSS:NMESsage:NAV:EPHemeris:TOE on page 521
"Square Root of Semi-Major Axis - $A^{1/2}$ "	[:SOURCE<hw>] :BB:GNSS:SVID<ch>:QZSS:NMESsage:NAV:EPHemeris:SQRA on page 522
"Eccentricity - e "	[:SOURCE<hw>] :BB:GNSS:SVID<ch>:QZSS:NMESsage:NAV:EPHemeris:ECCentricity on page 523
"Inclination Angle - i_0 "	[:SOURCE<hw>] :BB:GNSS:SVID<ch>:QZSS:NMESsage:NAV:EPHemeris:IZERo on page 524
"Longitude of Ascending Node - Ω_0 "	[:SOURCE<hw>] :BB:GNSS:SVID<ch>:QZSS:NMESsage:NAV:EPHemeris:OZERo on page 525

Orbit and orbit perturbation errors settings

Parameter	Remote command:
"Argument of Perigee - ω "	[:SOURCE<hw>] :BB:GNSS:SVID<ch>:QZSS:NMESSage:NAV:EPHemeris:OMEGa on page 526
"Mean Anomaly - M_0 "	[:SOURCE<hw>] :BB:GNSS:SVID<ch>:QZSS:NMESSage:NAV:EPHemeris:MZERo:UNSCaled on page 527
"Rate of Inclination Angle - i "	[:SOURCE<hw>] :BB:GNSS:SVID<ch>:QZSS:NMESSage:NAV:EPHemeris:IDOT on page 528
"Rate of Right Ascension - Ω "	[:SOURCE<hw>] :BB:GNSS:SVID<ch>:QZSS:NMESSage:NAV:EPHemeris:ODOT:UNSCaled on page 528

Table 13-14: LNAV

Parameter	Remote command:
"Issue of Data, Ephemeris - IODE"	[:SOURCE<hw>] :BB:GNSS:SVID<ch>:QZSS:NMESSage:NAV:EPHemeris:IODE on page 521
"Mean Motion Difference - Δ_n "	[:SOURCE<hw>] :BB:GNSS:SVID<ch>:QZSS:NMESSage:NAV:EPHemeris:NDELta on page 530

Table 13-15: CNAV

Parameter	Remote command:
"Rate of Right Ascension Diff. - $\Delta\Omega$ "	[:SOURCE<hw>] :BB:GNSS:SVID<ch>:QZSS:NMESSage:CNAV:EPHemeris:DODot on page 529
"Mean Motion Difference - Δ_{n0} "	[:SOURCE<hw>] :BB:GNSS:SVID<ch>:QZSS:NMESSage:CNAV:EPHemeris:NDELta on page 530
"Rate of Mean Motion Diff. - Δ_{n0} "	[:SOURCE<hw>] :BB:GNSS:SVID<ch>:QZSS:NMESSage:CNAV:EPHemeris:DNDot on page 530
"Change Rate in Semi-major Axis - A "	[:SOURCE<hw>] :BB:GNSS:SVID<ch>:QZSS:NMESSage:CNAV:EPHemeris:ADOT on page 531
"Semi-Major Axis Difference - ΔA "	[:SOURCE<hw>] :BB:GNSS:SVID<ch>:QZSS:NMESSage:CNAV:EPHemeris:ADELta on page 531

QZSS > Orbit Perturbation

Comprises the parameters of the QZSS satellites.

Table 13-16: LNAV and CNAV

Parameter	Remote command:
"Cosine Difference of Latitude - C_{uc} "	[:SOURCE<hw>] :BB:GNSS:SVID<ch>:QZSS:NMESSage:NAV:EPHemeris:CUC on page 534
"Sine Difference of Latitude - C_{us} "	[:SOURCE<hw>] :BB:GNSS:SVID<ch>:QZSS:NMESSage:NAV:EPHemeris:CUS on page 535
"Cosine Difference of Orbital Radius - C_{rc} "	[:SOURCE<hw>] :BB:GNSS:SVID<ch>:QZSS:NMESSage:NAV:EPHemeris:CRc on page 536
"Sine Difference of Orbital Radius - C_{rs} "	[:SOURCE<hw>] :BB:GNSS:SVID<ch>:QZSS:NMESSage:NAV:EPHemeris:CRS:UNSCaled on page 537

Orbit and orbit perturbation errors settings

Parameter	Remote command:
"Cosine Difference of Inclination - C_{ic} "	[:SOURCE<hw>] :BB:GNSS:SVID<ch>:QZSS:NMESSsage:NAV:EPHemeris:CIC on page 538
"Sine Difference of Inclination - C_{is} "	[:SOURCE<hw>] :BB:GNSS:SVID<ch>:QZSS:NMESSsage:NAV:EPHemeris:CIS on page 539

NavIC > Orbit

Comprises the orbit parameters of the NavIC satellites.

Parameter	Remote command:
"Issue of Data, Ephemeris & Clock - IODEC"	[:SOURCE<hw>] :BB:GNSS:SVID<ch>:NAVic:NMESSsage:NAV:EPHemeris:IODE on page 521
"Reference Time of Ephemeris - t_{0e} "	[:SOURCE<hw>] :BB:GNSS:SVID<ch>:NAVic:NMESSsage:NAV:EPHemeris:TOE on page 521
"Square Root of Semi-Major Axis - $A^{1/2}$ "	[:SOURCE<hw>] :BB:GNSS:SVID<ch>:NAVic:NMESSsage:NAV:EPHemeris:SQRA on page 522
"Eccentricity - e "	[:SOURCE<hw>] :BB:GNSS:SVID<ch>:NAVic:NMESSsage:NAV:EPHemeris:ECCentricity on page 523
"Inclination Angle - i_0 "	[:SOURCE<hw>] :BB:GNSS:SVID<ch>:NAVic:NMESSsage:NAV:EPHemeris:IZERo on page 524
"Longitude of Ascending Node - Ω_0 "	[:SOURCE<hw>] :BB:GNSS:SVID<ch>:NAVic:NMESSsage:NAV:EPHemeris:OZERo on page 525
"Argument of Perigee - ω "	[:SOURCE<hw>] :BB:GNSS:SVID<ch>:NAVic:NMESSsage:NAV:EPHemeris:OMEGa on page 526
"Mean Anomaly - M_0 "	[:SOURCE<hw>] :BB:GNSS:SVID<ch>:NAVic:NMESSsage:NAV:EPHemeris:MZERo on page 527
"Rate of Inclination Angle - i'' "	[:SOURCE<hw>] :BB:GNSS:SVID<ch>:NAVic:NMESSsage:NAV:EPHemeris:IDOT on page 527
"Rate of Right Ascension - Ω'' "	[:SOURCE<hw>] :BB:GNSS:SVID<ch>:NAVic:NMESSsage:NAV:EPHemeris:ODOT on page 528
"Mean Motion Difference - Δ_n "	[:SOURCE<hw>] :BB:GNSS:SVID<ch>:NAVic:NMESSsage:NAV:EPHemeris:NDELta:UNSCaled on page 529

NavIC > Orbit Perturbation

Comprises the parameters of the NavIC satellites.

Parameter	Remote command:
"Cosine Difference of Latitude - C_{uc} "	[:SOURCE<hw>] :BB:GNSS:SVID<ch>:NAVic:NMESSsage:NAV:EPHemeris:CUC on page 534
"Sine Difference of Latitude - C_{us} "	[:SOURCE<hw>] :BB:GNSS:SVID<ch>:NAVic:NMESSsage:NAV:EPHemeris:CUS on page 535
"Cosine Difference of Orbital Radius - C_{rc} "	[:SOURCE<hw>] :BB:GNSS:SVID<ch>:NAVic:NMESSsage:NAV:EPHemeris:CRC on page 536

Parameter	Remote command:
"Sine Difference of Orbital Radius - C_{rs} "	<code>[:SOURCE<hw>] :BB:GNSS:SVID<ch>:NAVic:NMESSage:NAV:EPHemeris:CRS</code> on page 537
"Cosine Difference of Inclination - C_{ic} "	<code>[:SOURCE<hw>] :BB:GNSS:SVID<ch>:NAVic:NMESSage:NAV:EPHemeris:CIC</code> on page 538
"Sine Difference of Inclination - C_{is} "	<code>[:SOURCE<hw>] :BB:GNSS:SVID<ch>:NAVic:NMESSage:NAV:EPHemeris:CIS</code> on page 539

Show Scaled Values

Switches between scaled and unscaled values representation.

Navigation message values are recalculated automatically.

Remote command:

`[:SOURCE<hw>] :BB:GNSS:SSValues` on page 483

13.7 Clock errors settings

Access:

1. Select "Simulation Configuration > Satellites > GNSS system > SV# > SV Config > Signals Configuration".
2. Select "Nav Msg Control > Edit".
3. Select "Nav Msg Content > Config > Clock".

Per default, the navigation message parameters are set to values corresponding to the values retrieved from the constellation data source.

Orbit	Clock	Additional Data	Time Conversion for All SVs	Ionosphere for All SVs
Issue of Data, Clock - IODC		224	Reference Time of Clock - t_{0c}	
				288 000 s
a_{f0}		-0.000 000 427 5 s	a_{f1}	0.000 000 000 003 6 s/s
a_{f2}		0.000 000 000 000 000 00 s/s ²	Group Delay - T_{gd}	0.000 000 000 0 s

Show Scaled Values

Changing these values leads to deviation between the simulated and the broadcasted navigation message and thus deliberate errors. The generated signal can be used for testing the receiver's ability to cope with errors.

SBAS corrections can be activated for error compensation.

Available navigation message parameters depend on the GNSS system and selected navigation message type, see [Chapter 13.3.3, "About clock and time conversion parameters and errors"](#), on page 201.

Settings

GPS > Clock.....	224
Galileo > Clock.....	224
GLONASS > Clock.....	225
BeiDou > Clock.....	225
QZSS > Clock.....	226
NavIC > Clock.....	226
Show Scaled Values.....	227

GPS > Clock

Comprises the parameters of the GPS satellites.

Table 13-17: LNAV and CNAV

Parameter	Remote command:
"Reference Time of Clock - t_{0c} "	[:SOURCE<hw>] :BB:GNSS:SVID<ch>:GPS:NMESsage: LNAV:CCORrection:TOC on page 541
" a_{10} " to " a_{12} "	[:SOURCE<hw>] :BB:GNSS:SVID<ch>:GPS:NMESsage: LNAV:CCORrection:AF<s2us0> on page 542
"Group Delay - T_{gd} "	[:SOURCE<hw>] :BB:GNSS:SVID<ch>:GPS:NMESsage: LNAV:CCORrection:TGD on page 542

Table 13-18: LNAV

Parameter	Remote command:
"Issue of Data, Clock - IODC"	[:SOURCE<hw>] :BB:GNSS:SVID<ch>:GPS:NMESsage: LNAV:EPHemeris:IODC on page 540

Table 13-19: CNAV

Parameter	Remote command:
"ISC _{L1C/A} "	[:SOURCE<hw>] :BB:GNSS:SVID<ch>:GPS:NMESsage: CNAV:CCORrection:ISC:L1CA on page 543
"ISC _{L2C} "	[:SOURCE<hw>] :BB:GNSS:SVID<ch>:GPS:NMESsage: CNAV:CCORrection:ISC:L2C on page 543
"ISC _{L5I5} "	[:SOURCE<hw>] :BB:GNSS:SVID<ch>:GPS:NMESsage: CNAV:CCORrection:ISC:L5I on page 543
"ISC _{L5Q5} "	[:SOURCE<hw>] :BB:GNSS:SVID<ch>:GPS:NMESsage: CNAV:CCORrection:ISC:L5Q on page 543

Galileo > Clock

Comprises the clock parameters of the Galileo satellites.

Table 13-20: INAV and FNAV

Parameter	Remote command:
"Time of Clock - t_{0c} (E1-E5A)"	<code>[:SOURCE<hw>] :BB:GNSS:SVID<ch>:GALileo:NMESsage:INAV:CCORrection:TOC</code> on page 540
" a_{f0} (E1-E5A)" to " a_{f2} (E1-E5A)"	<code>[:SOURCE<hw>] :BB:GNSS:SVID<ch>:GALileo:NMESsage:INAV:CCORrection:AF<s2us0></code> on page 541
"Broadcast Group Delay - BGD (E1-E5A)"	<code>[:SOURCE<hw>] :BB:GNSS:SVID<ch>:GALileo:NMESsage:INAV:CCORrection:BGDA</code> on page 544

Table 13-21: INAV

Parameter	Remote command:
"Broadcast Group Delay - BGD (E1-E5B)"	<code>[:SOURCE<hw>] :BB:GNSS:SVID<ch>:GALileo:NMESsage:INAV:CCORrection:BGDB</code> on page 543

GLONASS > Clock

Comprises the parameters of the GLONASS satellites.

Parameter	Remote command:
"Time of Day - t_b "	<code>[:SOURCE<hw>] :BB:GNSS:SVID<ch>:GLONass:NMESsage:NAV:EPHemeris:TOE?</code> on page 532
" t_b Interval"	<code>[:SOURCE<hw>] :BB:GNSS:SVID<ch>:GLONass:NMESsage:NAV:EPHemeris:TINterval?</code> on page 532
" T_n ($-a_{f0}$)"	<code>[:SOURCE<hw>] :BB:GNSS:SVID<ch>:GLONass:NMESsage:NAV:CCORrection:TAUN</code> on page 544
" Y_n (a_{f1})"	<code>[:SOURCE<hw>] :BB:GNSS:SVID<ch>:GLONass:NMESsage:NAV:CCORrection:GAMN</code> on page 544
" ΔT_n (T_{gd})"	<code>[:SOURCE<hw>] :BB:GNSS:SVID<ch>:GLONass:NMESsage:NAV:CCORrection:DTAU</code> on page 544

BeiDou > Clock

Comprises the parameters of the BeiDou satellites.

Table 13-22: DNAV and CNAV

Parameter	Remote command:
"ReferenceTime of Clock - t_{0c} "	<code>[:SOURCE<hw>] :BB:GNSS:SVID<ch>:BEIDou:NMESsage:DNAV:CCORrection:TOC</code> on page 540
" a_{f0} " to " a_{f2} "	<code>[:SOURCE<hw>] :BB:GNSS:SVID<ch>:BEIDou:NMESsage:DNAV:CCORrection:AF<s2us0></code> on page 541

Table 13-23: DNAV

Parameter	Remote command:
"AODC"	[:SOURCE<hw>] :BB:GNSS:SVID<ch>:BEIDou:NMESsage:DNAV:EPHemeris:IODC on page 540
"Group Delay B1 - T_{GD1} ", "Group Delay B2 - T_{GD2} "	[:SOURCE<hw>] :BB:GNSS:SVID<ch>:BEIDou:NMESsage:DNAV:CCORrection:TGD<s2us> on page 542

Table 13-24: CNAV

Parameter	Remote command:
"Group Delay - T_{gd} "	[:SOURCE<hw>] :BB:GNSS:SVID<ch>:BEIDou:NMESsage:CNAV:CCORrection:TGD on page 542

QZSS > Clock

Comprises the parameters of the QZSS satellites.

Table 13-25: LNAV and CNAV

Parameter	Remote command:
"Reference Time of Clock - t_{0c} "	[:SOURCE<hw>] :BB:GNSS:SVID<ch>:QZSS:NMESsage:NAV:CCORrection:TOC on page 540
" a_{f0} " to " a_{f2} "	[:SOURCE<hw>] :BB:GNSS:SVID<ch>:QZSS:NMESsage:NAV:CCORrection:AF<s2us0> on page 541
"Group Delay - T_{gd} "	[:SOURCE<hw>] :BB:GNSS:SVID<ch>:QZSS:NMESsage:NAV:CCORrection:TGD on page 542

Table 13-26: LNAV

Parameter	Remote command:
"Issue of Data, Clock - IODC"	[:SOURCE<hw>] :BB:GNSS:SVID<ch>:QZSS:NMESsage:NAV:EPHemeris:IODC on page 540

Table 13-27: CNAV

Parameter	Remote command:
"ISC _{L1C/A} "	[:SOURCE<hw>] :BB:GNSS:SVID<ch>:QZSS:NMESsage:CNAV:CCORrection:ISC:L1CA on page 543
"ISC _{L2C} "	[:SOURCE<hw>] :BB:GNSS:SVID<ch>:QZSS:NMESsage:CNAV:CCORrection:ISC:L2C on page 543
"ISC _{L5I} "	[:SOURCE<hw>] :BB:GNSS:SVID<ch>:QZSS:NMESsage:CNAV:CCORrection:ISC:L5I on page 543
"ISC _{L5Q} "	[:SOURCE<hw>] :BB:GNSS:SVID<ch>:QZSS:NMESsage:CNAV:CCORrection:ISC:L5Q on page 543

NavIC > Clock

Comprises the parameters of the NavIC satellites.

Parameter	Remote command:
"Reference Time of Clock - t_{0c} "	[:SOURCE<hw>] :BB:GNSS:SVID<ch>:NAVIC:NMESSage:NAV:CCORrection:TOC on page 540
" a_{i0} " to " a_{i2} "	[:SOURCE<hw>] :BB:GNSS:SVID<ch>:NAVIC:NMESSage:NAV:CCORrection:AF<s2us0> on page 541
"Group Delay - T_{gd} "	[:SOURCE<hw>] :BB:GNSS:SVID<ch>:NAVIC:NMESSage:NAV:CCORrection:TGD on page 542

Show Scaled Values

Switches between scaled and unscaled values representation.

Navigation message values are recalculated automatically.

Remote command:

[:SOURCE<hw>] :BB:GNSS:SSValues on page 483

13.8 Time conversion errors settings

Access:

1. Select "Simulation Configuration > Satellites > GNSS system > SV# > SV Config > Signals Configuration".
2. Select "**Nav Msg Control > Edit**".
3. Select "**Nav Msg Content > Config > Time Conversion**".
Time conversion parameters are read-only and common for all SV of one GNSS system.
4. To change the time conversion parameters of all GPS SVs for example, select "SV# > SV Config" > "**Copy Modulation Control to SV-ID = All**".

Per default, the navigation message parameters are set to values corresponding to the values retrieved from the constellation data source.

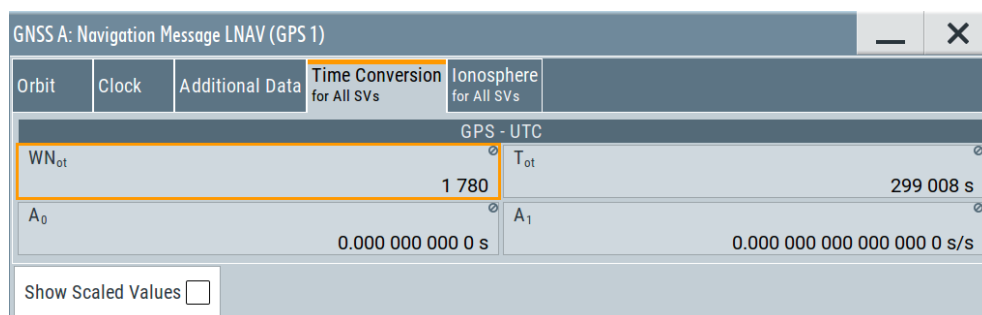

Changing these values leads to deviation between the simulated and the broadcasted navigation message and thus deliberate errors. SBAS corrections can be activated for error compensation.

Available navigation message parameters depend GNSS system and selected navigation message type.

Settings

GPS > Time Conversion..... 228
 Galileo > Time Conversion..... 229
 GLONASS > Time Conversion..... 229
 BeiDou > Time Conversion..... 230
 QZSS > Time Conversion..... 231
 NavIC > Time Conversion..... 231
 Show Scaled Values..... 232

GPS > Time Conversion

Comprises the parameters of the GPS satellites.

Table 13-28: GPS - UTC (LNAV and CNAV)

Parameter	Remote command:
"W _{Not} "	[:SOURCE<hw>] :BB:GNSS:SV:GPS:NMESSage:LNAV:TIME:CONVersion:UTC:WNOT on page 554
"T _{ot} "	[:SOURCE<hw>] :BB:GNSS:SV:GPS:NMESSage:LNAV:TIME:CONVersion:UTC:TOT on page 555
"A ₀ "	[:SOURCE<hw>] :BB:GNSS:SV:GPS:NMESSage:LNAV:TIME:CONVersion:UTC:AZERo on page 558
"A ₁ "	[:SOURCE<hw>] :BB:GNSS:SV:GPS:NMESSage:LNAV:TIME:CONVersion:UTC:AONE on page 557

Table 13-29: GPS - UTC (CNAV)

Parameter	Remote command:
"A ₂ "	[:SOURCE<hw>] :BB:GNSS:SV:GPS:NMESSage:CNAV:TIME:CONVersion:UTC:ATWO on page 555

Table 13-30: GPS - Galileo (CNAV)

Parameter	Remote command:
"W _{Not} "	[:SOURCE<hw>] :BB:GNSS:SV:GPS:NMESSage:CNAV:TIME:CONVersion:GALileo:WNOT on page 560
"T _{ot} "	[:SOURCE<hw>] :BB:GNSS:SV:GPS:NMESSage:CNAV:TIME:CONVersion:GALileo:TOT on page 561
"A ₀ "	[:SOURCE<hw>] :BB:GNSS:SV:GPS:NMESSage:CNAV:TIME:CONVersion:GALileo:AZERo on page 561
"A ₁ "	[:SOURCE<hw>] :BB:GNSS:SV:GPS:NMESSage:CNAV:TIME:CONVersion:GALileo:AONE on page 562
"A ₂ "	[:SOURCE<hw>] :BB:GNSS:SV:GPS:NMESSage:CNAV:TIME:CONVersion:GALileo:ATWO on page 562

Table 13-31: GPS - GLONASS (CNAV)

Parameter	Remote command:
W_{Not}	<code>[:SOURCE<hw>] :BB:GNSS:SV:GPS:NMESSsage:CNAV:TIME:CONVersion:GLONass:WNOT</code> on page 562
T_{ot}	<code>[:SOURCE<hw>] :BB:GNSS:SV:GPS:NMESSsage:CNAV:TIME:CONVersion:GLONass:TOT</code> on page 562
A_0	<code>[:SOURCE<hw>] :BB:GNSS:SV:GPS:NMESSsage:CNAV:TIME:CONVersion:GLONass:AZERo</code> on page 563
A_1	<code>[:SOURCE<hw>] :BB:GNSS:SV:GPS:NMESSsage:CNAV:TIME:CONVersion:GLONass:AONE</code> on page 563
A_2	<code>[:SOURCE<hw>] :BB:GNSS:SV:GPS:NMESSsage:CNAV:TIME:CONVersion:GLONass:ATWO</code> on page 563

Galileo > Time Conversion

Comprises the parameters of the Galileo satellites.

Table 13-32: Galileo - UTC (INAV and FNAV)

Parameter	Remote command:
" W_{Not} "	<code>[:SOURCE<hw>] :BB:GNSS:SV:GALileo:NMESSsage:INAV:TIME:CONVersion:UTC:WNOT</code> on page 554
" T_{ot} "	<code>[:SOURCE<hw>] :BB:GNSS:SV:GALileo:NMESSsage:INAV:TIME:CONVersion:UTC:TOT</code> on page 555
" A_0 "	<code>[:SOURCE<hw>] :BB:GNSS:SV:GALileo:NMESSsage:INAV:TIME:CONVersion:UTC:AZERo</code> on page 558
" A_1 "	<code>[:SOURCE<hw>] :BB:GNSS:SV:GALileo:NMESSsage:INAV:TIME:CONVersion:UTC:AONE</code> on page 556

Table 13-33: Galileo - GPS (INAV and FNAV)

Parameter	Remote command:
" W_{Not} "	<code>[:SOURCE<hw>] :BB:GNSS:SV:GALileo:NMESSsage:INAV:TIME:CONVersion:GPS:WNOT</code> on page 558
" T_{ot} "	<code>[:SOURCE<hw>] :BB:GNSS:SV:GALileo:NMESSsage:INAV:TIME:CONVersion:GPS:TOT</code> on page 559
" A_0 "	<code>[:SOURCE<hw>] :BB:GNSS:SV:GALileo:NMESSsage:INAV:TIME:CONVersion:GPS:AZERo</code> on page 559
" A_1 "	<code>[:SOURCE<hw>] :BB:GNSS:SV:GALileo:NMESSsage:INAV:TIME:CONVersion:GPS:AONE</code> on page 560

GLONASS > Time Conversion

Comprises the parameters of the GLONASS satellites.

Parameter	Remote command:
" $\tau_c(-A_0)$ "	[:SOURCE<hw>] :BB:GNSS:SV:GLONASS:NMESSsage:NAV:TIME:CONVersion:UTC:AZERo on page 558
" $\gamma_n(A_1)$ "	[:SOURCE<hw>] :BB:GNSS:SV:GLONASS:NMESSsage:NAV:TIME:CONVersion:UTC:AONE on page 556
" $\tau_{GPS}(A_0)$ "	[:SOURCE<hw>] :BB:GNSS:SV:GLONASS:NMESSsage:NAV:TIME:CONVersion:GPS:AZERo on page 559

BeiDou > Time Conversion

Comprises the parameters of the BeiDou satellites.

Table 13-34: BeiDou - UTC (DNAV and CNAV)

Parameter	Remote command:
" W_{Not} "	[:SOURCE<hw>] :BB:GNSS:SV:BEIDou:NMESSsage:DNAV:TIME:CONVersion:UTC:WNOT on page 554
" T_{ot} "	[:SOURCE<hw>] :BB:GNSS:SV:BEIDou:NMESSsage:DNAV:TIME:CONVersion:UTC:TOT on page 555
" A_0 "	[:SOURCE<hw>] :BB:GNSS:SV:BEIDou:NMESSsage:DNAV:TIME:CONVersion:UTC:AZERo on page 558
" A_1 "	[:SOURCE<hw>] :BB:GNSS:SV:BEIDou:NMESSsage:DNAV:TIME:CONVersion:UTC:AONE on page 556

Table 13-35: BeiDou - GPS (DNAV and CNAV)

Parameter	Remote command:
" A_0 "	[:SOURCE<hw>] :BB:GNSS:SV:BEIDou:NMESSsage:DNAV:TIME:CONVersion:GPS:AZERo on page 559
" A_1 "	[:SOURCE<hw>] :BB:GNSS:SV:BEIDou:NMESSsage:DNAV:TIME:CONVersion:GPS:AONE on page 560

Table 13-36: BeiDou - Galileo (DNAV and CNAV)

Parameter	Remote command:
" A_0 "	[:SOURCE<hw>] :BB:GNSS:SV:BEIDou:NMESSsage:DNAV:TIME:CONVersion:GALileo:AZERo on page 561
" A_1 "	[:SOURCE<hw>] :BB:GNSS:SV:BEIDou:NMESSsage:DNAV:TIME:CONVersion:GALileo:AONE on page 561

Table 13-37: BeiDou - GLONASS (DNAV and CNAV)

Parameter	Remote command:
" A_0 "	[:SOURCE<hw>] :BB:GNSS:SV:BEIDou:NMESSsage:DNAV:TIME:CONVersion:GLONASS:AZERo on page 563
" A_1 "	[:SOURCE<hw>] :BB:GNSS:SV:BEIDou:NMESSsage:DNAV:TIME:CONVersion:GLONASS:AONE on page 563

QZSS > Time Conversion

Comprises the parameters of the QZSS satellites.

Table 13-38: QZSS - UTC (CNAV)

Parameter	Remote command:
"W _{Not} "	[:SOURCE<hw>] :BB:GNSS:SV:QZSS:NMESSsage:CNAV:TIME:CONVersion:UTC:WNOT on page 553
"T _{ot} "	[:SOURCE<hw>] :BB:GNSS:SV:QZSS:NMESSsage:CNAV:TIME:CONVersion:UTC:TOT on page 554
"A ₀ "	[:SOURCE<hw>] :BB:GNSS:SV:QZSS:NMESSsage:CNAV:TIME:CONVersion:UTC:AZERo on page 557
"A ₁ "	[:SOURCE<hw>] :BB:GNSS:SV:QZSS:NMESSsage:CNAV:TIME:CONVersion:UTC:AONE on page 556
"A ₂ "	[:SOURCE<hw>] :BB:GNSS:SV:QZSS:NMESSsage:CNAV:TIME:CONVersion:UTC:ATWO on page 555

NavIC > Time Conversion

Comprises the parameters of the NavIC satellites.

Table 13-39: NavIC - UTC

Parameter	Remote command:
"W _{Not} "	[:SOURCE<hw>] :BB:GNSS:SV:NAVic:NMESSsage:NAV:TIME:CONVersion:UTC:WNOT on page 553
"T _{ot} "	[:SOURCE<hw>] :BB:GNSS:SV:NAVic:NMESSsage:NAV:TIME:CONVersion:UTC:TOT on page 554
"A ₀ "	[:SOURCE<hw>] :BB:GNSS:SV:NAVic:NMESSsage:NAV:TIME:CONVersion:UTC:AZERo on page 557
"A ₁ "	[:SOURCE<hw>] :BB:GNSS:SV:NAVic:NMESSsage:NAV:TIME:CONVersion:UTC:AONE on page 556
"A ₂ "	[:SOURCE<hw>] :BB:GNSS:SV:NAVic:NMESSsage:NAV:TIME:CONVersion:UTC:ATWO on page 555

Table 13-40: NavIC - GPS

Parameter	Remote command:
"W _{Not} "	[:SOURCE<hw>] :BB:GNSS:SV:NAVic:NMESSsage:NAV:TIME:CONVersion:GPS:WNOT on page 558
"T _{ot} "	[:SOURCE<hw>] :BB:GNSS:SV:NAVic:NMESSsage:NAV:TIME:CONVersion:GPS:TOT on page 558
"A ₀ "	[:SOURCE<hw>] :BB:GNSS:SV:NAVic:NMESSsage:NAV:TIME:CONVersion:GPS:AZERo on page 559
"A ₁ "	[:SOURCE<hw>] :BB:GNSS:SV:NAVic:NMESSsage:NAV:TIME:CONVersion:GPS:AONE on page 560
"A ₂ "	[:SOURCE<hw>] :BB:GNSS:SV:NAVic:NMESSsage:NAV:TIME:CONVersion:GPS:ATWO on page 560

Show Scaled Values

Switches between scaled and unscaled values representation.

Navigation message values are recalculated automatically.

Remote command:

[:SOURce<hw>] :BB:GNSS:SSValues on page 483

13.9 System errors settings

Access:

1. Select "Simulation Configuration > Satellites > GNSS system > SV# > SV Config > Signals Configuration".
2. Select real navigation data as data source.
For example, for a GPS SV ID, select "**Nav Msg Type > LNAV**".
3. Select "**Nav Msg Control > Edit**".
4. Select "**Nav Msg Content > Config > Additional Data**".

Per default, the navigation message parameters are set to values corresponding to the values retrieved from the constellation data source.

GNSS: Navigation Message LNAV (GPS 1)			
Orbit	Clock	Additional Data	Ionosphere for All SVs
SV Health		0	User Range Accuracy Index
Anti-Spoofing Flag	<input type="checkbox"/>		SV Config
L2 P Data Flag	<input type="checkbox"/>		Code On L2
Fit Interval Flag	<input type="checkbox"/>		Age of Data Offset
Subframe 1, Reserved 1 (23 bits, Word 4)		2 796 202	Subframe 1, Reserved 2 (24 bits, Word 5)
Subframe 1, Reserved 3 (24 bits, Word 6)		11 184 810	Subframe 1, Reserved 4 (16 bits, Word 7)
			P Code On
			31
			11 184 810
			43 690

Available navigation message parameters depend GNSS system and selected navigation message type.

5. To simulate errors, change the values.
For example, set "User Range Accuracy Index (URA) = 12".

With this URA index, the selected SV is set to invisible.

Changing any navigation message value leads to deviation between the simulated and the broadcasted navigation message and thus to a deliberated error.

The generated signal can be used for testing the receiver's ability to cope with errors.

SBAS corrections can be activated for error compensation.

Settings

GPS > Additional Data.....	233
Galileo > Additional Data.....	234
GLONASS > Additional Data.....	235
BeiDou > Additional Data.....	235
QZSS > Additional Data.....	236
NavIC > Additional Data.....	237
Show Scaled Values.....	237

GPS > Additional Data

Comprises the parameters of the GPS satellites.

Table 13-41: LNAV

Parameter	Remote command:
"SV Health"	[:SOURCE<hw>] :BB:GNSS:SVID<ch>:GPS: NMESsage:LNAV:EPHemeris:HEALth on page 547
"User Range Accuracy Index"	[:SOURCE<hw>] :BB:GNSS:SVID<ch>:GPS: NMESsage:LNAV:EPHemeris:URA on page 548
"Anti-Spoofing Flag"	[:SOURCE<hw>] :BB:GNSS:SVID<ch>:GPS: NMESsage:LNAV:EPHemeris:ASF Lag on page 548
"SV Config"	[:SOURCE<hw>] :BB:GNSS:SVID<ch>:GPS: NMESsage:LNAV:EPHemeris:SVConfig on page 548
"Code On L2"	[:SOURCE<hw>] :BB:GNSS:SVID<ch>:GPS: NMESsage:LNAV:EPHemeris:CLTMode on page 548
"L2 P Data Flag"	[:SOURCE<hw>] :BB:GNSS:SVID<ch>:GPS: NMESsage:LNAV:EPHemeris:LTPData on page 548
"Fit Interval Flag"	[:SOURCE<hw>] :BB:GNSS:SVID<ch>:GPS: NMESsage:LNAV:EPHemeris:FIFLag on page 549
"Age of Data Offset"	[:SOURCE<hw>] :BB:GNSS:SVID<ch>:GPS: NMESsage:LNAV:EPHemeris:AODO? on page 549
"Subframe 1, Reserved 1 (23 bits, Word 4)" "Subframe 1, Reserved 2 (24 bits, Word 5)" "Subframe 1, Reserved 3 (24 bits, Word 6)" "Subframe 1, Reserved 4 (16 bits, Word 7)"	[:SOURCE<hw>] :BB:GNSS:SVID<ch>:GPS: NMESsage:LNAV:EPHemeris:SFlReserved<s2us>? on page 549

Table 13-42: CNAV

Parameter	Remote command:
"Alert Flag"	[:SOURCE<hw>] :BB:GNSS:SVID<ch>:GPS: NMESsage:CNAV:EPHemeris:ALERT on page 545
"L1 Health"	[:SOURCE<hw>] :BB:GNSS:SVID<ch>:GPS: NMESsage:CNAV:EPHemeris:L1Health on page 545
"L2 Health"	[:SOURCE<hw>] :BB:GNSS:SVID<ch>:GPS: NMESsage:CNAV:EPHemeris:L2Health on page 545

Parameter	Remote command:
"L5 Health"	[:SOURCE<hw>] :BB:GNSS:SVID<ch>:GPS: NMESsage:CNAV:EPHemeris:L5Health on page 545
"ED Accuracy Index"	[:SOURCE<hw>] :BB:GNSS:SVID<ch>:GPS: NMESsage:CNAV:EPHemeris:URA on page 548
"NED Accuracy Index"	[:SOURCE<hw>] :BB:GNSS:SVID<ch>:GPS: NMESsage:CNAV:EPHemeris:NED0 on page 545
"NED Accuracy Change Index"	[:SOURCE<hw>] :BB:GNSS:SVID<ch>:GPS: NMESsage:CNAV:EPHemeris:NED1 on page 545
"NED Accuracy Change Rate Index"	[:SOURCE<hw>] :BB:GNSS:SVID<ch>:GPS: NMESsage:CNAV:EPHemeris:NED2 on page 545
"Data Predict Week Number -WN _{op} "	[:SOURCE<hw>] :BB:GNSS:SVID<ch>:GPS: NMESsage:CNAV:EPHemeris:WNOF on page 546
"Data Predict Time of Week - t _{op} "	[:SOURCE<hw>] :BB:GNSS:SVID<ch>:GPS: NMESsage:CNAV:EPHemeris:TOP on page 546
"Integrity Status Flag"	[:SOURCE<hw>] :BB:GNSS:SVID<ch>:GPS: NMESsage:CNAV:EPHemeris:ISFLag on page 546
"L2C Phasing"	[:SOURCE<hw>] :BB:GNSS:SVID<ch>:GPS: NMESsage:CNAV:EPHemeris:L2CPhasing on page 546

Galileo > Additional Data

Comprises the parameters of the Galileo satellites.

Table 13-43: INAV

Parameter	Remote command:
"Signal in Space Accuracy Index"	[:SOURCE<hw>] :BB:GNSS:SVID<ch>:GALileo: NMESsage:INAV:EPHemeris:SISA on page 549
"Data Validity Status - E1B _{DVS} "	[:SOURCE<hw>] :BB:GNSS:SVID<ch>:GALileo: NMESsage:INAV:E1BDVS on page 550
"Data Validity Status - E5b _{DVS} "	[:SOURCE<hw>] :BB:GNSS:SVID<ch>:GALileo: NMESsage:INAV:E5BDVS on page 550
"Signal Health Status - E1B _{HS} "	[:SOURCE<hw>] :BB:GNSS:SVID<ch>:GALileo: NMESsage:INAV:E1BHS on page 550
"Signal Health Status - E5b _{HS} "	[:SOURCE<hw>] :BB:GNSS:SVID<ch>:GALileo: NMESsage:INAV:E5BHS on page 550
"SAR configuration"	
"Mode"	[:SOURCE<hw>] :BB:GNSS:SVID<ch>:GALileo: NMESsage:INAV:EPHemeris:SAR:MODE on page 550
"RLM Data 1" to "RLM Data 4/8" (requires "Mode > Short/Long RLM")	[:SOURCE<hw>] :BB:GNSS:SVID<ch>:GALileo: NMESsage:INAV:EPHemeris:SAR:RLM<s2us> on page 551
"Spare Data" (requires "Mode > Spare")	[:SOURCE<hw>] :BB:GNSS:SVID<ch>:GALileo: NMESsage:INAV:EPHemeris:SAR:SPARe on page 551

Table 13-44: FNAV

Parameter	Remote command:
"Signal in Space Accuracy Index"	<code>[:SOURCE<hw>] :BB:GNSS:SVID<ch>:GALileo:NMESsage:FNAV:EPHemeris:SISA</code> on page 549
"Data Validity Status - E5a _{DVS} "	<code>[:SOURCE<hw>] :BB:GNSS:SVID<ch>:GALileo:NMESsage:FNAV:E5ADVS</code> on page 552
"Signal Health Status - E5a _{HS} "	<code>[:SOURCE<hw>] :BB:GNSS:SVID<ch>:GALileo:NMESsage:FNAV:E5AHS</code> on page 552

GLONASS > Additional Data

Comprises the parameters of the GLONASS satellites.

Parameter	Remote command:
"SV Health - B _n (I _n)"	<code>[:SOURCE<hw>] :BB:GNSS:SVID<ch>:GLONass:NMESsage:NAV:EPHemeris:HEALTh</code> on page 547
"User Range Accuracy - F _T "	<code>[:SOURCE<hw>] :BB:GNSS:SVID<ch>:GLONass:NMESsage:NAV:EPHemeris:URA</code> on page 547
"Satellite Ephemeris Type - M"	<code>[:SOURCE<hw>] :BB:GNSS:SVID<ch>:GLONass:NMESsage:NAV:EPHemeris:SEType</code> on page 552
"CDMA Field M"	<code>[:SOURCE<hw>] :BB:GNSS:SVID<ch>:GLONass:NMESsage:NAV:EPHemeris:CFM</code> on page 552
"Satellite Operation mode - P"	<code>[:SOURCE<hw>] :BB:GNSS:SVID<ch>:GLONass:NMESsage:NAV:EPHemeris:P</code> on page 552
"Age of Ephemeris Page - P1"	<code>[:SOURCE<hw>] :BB:GNSS:SVID<ch>:GLONass:NMESsage:NAV:EPHemeris:AOEP</code> on page 553
"t _b Alignment - P2"	<code>[:SOURCE<hw>] :BB:GNSS:SVID<ch>:GLONass:NMESsage:NAV:EPHemeris:TALignment</code> on page 553
"E _n "	<code>[:SOURCE<hw>] :BB:GNSS:SVID<ch>:GLONass:NMESsage:NAV:CCORrection:EN</code> on page 553

BeiDou > Additional Data

Comprises the parameters of the BeiDou satellites.

Table 13-45: DNAV

Parameter	Remote command:
"SV Health"	<code>[:SOURCE<hw>] :BB:GNSS:SVID<ch>:BEIDou:NMESsage:DNAV:EPHemeris:HEALTh</code> on page 547
"User Range Accuracy Index"	<code>[:SOURCE<hw>] :BB:GNSS:SVID<ch>:BEIDou:NMESsage:DNAV:EPHemeris:URA</code> on page 548

Table 13-46: CNAV

Parameter	Remote command:
"Alert Flag"	<code>[:SOURCE<hw>] :BB:GNSS:SVID<ch>:BEIDou:NMESsage:CNAV:EPHemeris:ALERT</code> on page 545

QZSS > Additional Data

Comprises the parameters of the QZSS satellites.

Table 13-47: LNAV

Parameter	Remote command:
"SV Health"	[:SOURCE<hw>] :BB:GNSS:SVID<ch>:QZSS:NMESSagE:NAV:EPHemeris:HEALTH on page 547
"User Range Accuracy Index"	[:SOURCE<hw>] :BB:GNSS:SVID<ch>:QZSS:NMESSagE:NAV:EPHemeris:URA on page 547
"SV Config"	[:SOURCE<hw>] :BB:GNSS:SVID<ch>:QZSS:NMESSagE:NAV:EPHemeris:SVConfig on page 548
"Code On L2"	[:SOURCE<hw>] :BB:GNSS:SVID<ch>:QZSS:NMESSagE:NAV:EPHemeris:CLTMode on page 548
"L2 P Data Flag"	[:SOURCE<hw>] :BB:GNSS:SVID<ch>:QZSS:NMESSagE:NAV:EPHemeris:LTPData on page 548
"Fit Interval Flag"	[:SOURCE<hw>] :BB:GNSS:SVID<ch>:QZSS:NMESSagE:NAV:EPHemeris:FIFlag on page 549
"Age of Data Offset"	[:SOURCE<hw>] :BB:GNSS:SVID<ch>:QZSS:NMESSagE:NAV:EPHemeris:AODO? on page 549
"Subframe 1, Reserved 1" to "Subframe 1, Reserved 4"	[:SOURCE<hw>] :BB:GNSS:SVID<ch>:QZSS:NMESSagE:NAV:EPHemeris:SF1Reserved<s2us>? on page 549

Table 13-48: CNAV

Parameter	Remote command:
"Alert Flag"	[:SOURCE<hw>] :BB:GNSS:SVID<ch>:QZSS:NMESSagE:CNAV:EPHemeris:ALERT on page 545
"L1 Health"	[:SOURCE<hw>] :BB:GNSS:SVID<ch>:QZSS:NMESSagE:CNAV:EPHemeris:L1Health on page 545
"L2 Health"	[:SOURCE<hw>] :BB:GNSS:SVID<ch>:QZSS:NMESSagE:CNAV:EPHemeris:L2Health on page 545
"L5 Health"	[:SOURCE<hw>] :BB:GNSS:SVID<ch>:QZSS:NMESSagE:CNAV:EPHemeris:L5Health on page 545
"ED Accuracy Index"	[:SOURCE<hw>] :BB:GNSS:SVID<ch>:QZSS:NMESSagE:CNAV:EPHemeris:URA on page 547
"NED Accuracy Index"	[:SOURCE<hw>] :BB:GNSS:SVID<ch>:QZSS:NMESSagE:CNAV:EPHemeris:NED0 on page 545
"NED Accuracy Change Index"	[:SOURCE<hw>] :BB:GNSS:SVID<ch>:QZSS:NMESSagE:CNAV:EPHemeris:NED1 on page 545
"NED Accuracy Change Rate Index"	[:SOURCE<hw>] :BB:GNSS:SVID<ch>:QZSS:NMESSagE:CNAV:EPHemeris:NED2 on page 545
"Integrity Status Flag"	[:SOURCE<hw>] :BB:GNSS:SVID<ch>:QZSS:NMESSagE:CNAV:EPHemeris:ISFLag on page 546
"L2C Phasing"	[:SOURCE<hw>] :BB:GNSS:SVID<ch>:QZSS:NMESSagE:CNAV:EPHemeris:L2CPhasing on page 546

NavIC > Additional Data

Comprises the parameters of the NavIC satellites.

Parameter	Remote command:
"L5 Health"	[:SOURCE<hw>]:BB:GNSS:SVID<ch>:NAVic:NMESSage:NAV:EPHemeris:L5Health on page 547
"S Health"	[:SOURCE<hw>]:BB:GNSS:SVID<ch>:NAVic:NMESSage:NAV:EPHemeris:SEHealth on page 547
"User Range Accuracy"	[:SOURCE<hw>]:BB:GNSS:SVID<ch>:NAVic:NMESSage:NAV:EPHemeris:URA on page 547

Show Scaled Values

Switches between scaled and unscaled values representation.

Navigation message values are recalculated automatically.

Remote command:

[\[:SOURCE<hw>\]:BB:GNSS:SSValues](#) on page 483

14 SBAS corrections

Option: R&S SMW-K44 and R&S SMW-K106

A short introduction to the satellite-based augmentation system (SBAS) is provided in [Chapter 2.3, "SBAS overview"](#), on page 24. This section gives an overview of SBAS features in the context of this software.

14.1 About SBAS

The SBAS uses three types of services to improve augmentation:

- Transmission of ranging information for improved *visibility*
- Broadcast of correction data (error estimations) for improved *accuracy*
- Broadcast of coarse integrity information for improved *reliability*

The SBAS specification [RTCA MOPS DO-229](#) defines different message types that carry these coarse integrities or both integrity and wide area correction data information. The correction data can be fast, long-term and ionospheric, where:

- The fast corrections eliminate pseudorange errors
- The long-term corrections overcome errors in the satellites position or slow changing clock and ephemeris errors
- The ionospheric corrections are based on the user location

SBAS provides separate corrections for different error sources. In particular, SBAS corrects the following errors: Ionospheric error, GPS satellite timing errors and GPS satellite orbit errors. The latter two corrections are included for all GPS satellites that are monitored by SBAS. The ionospheric errors are corrected if the satellite orbit crosses the area covered by the SBAS iono grid points.

SBAS message types (MT)

According to [RTCA MOPS DO-229](#), SBAS correction data is transmitted by a subset of predefined message types. In this implementation, the SBAS information is not defined on a message-by-message basis but grouped according to the SBAS service and correction data type.

The [Table 14-1](#) list the SBAS message type with brief information on their content and information on the section, describing the related settings.

Table 14-1: SBAS message types (MT)

MT	Content	Related settings
1	PRN masks assignments	See Chapter 14.4.3.3, "PRN mask settings" , on page 254.
2 to 5	Fast corrections	See Chapter 14.4.3.4, "Fast correction settings" , on page 255.
6	Integrity information	Integrity information is included in Chapter 14.4.3.4, "Fast correction settings" , on page 255.

MT	Content	Related settings
7	Fast correction degradation factor	See Chapter 14.4.3.6, "Fast correction degradation factor configuration settings" , on page 259.
9	GEO navigation message	See Chapter 14.4.2.2, "Broadcasted orbit, clock and time conversion settings" , on page 247.
10	Degradation parameters	See "Degradation Factors" on page 265.
12	SBAS network time, UTC offset parameters	See Chapter 4.1, "Time settings" , on page 46.
17	GEO satellites almanacs	See "Message Schedule" on page 264.
18	Ionospheric grid point mask	Chapter 14.4.3.2, "Ionosphere grid settings" , on page 252.
24	Mixed fast and log-term correction data	Not supported
25	Long-term satellite error correction data	See Chapter 14.4.3.5, "Long-term correction file configuration settings" , on page 258.
26	Ionospheric delay corrections	Chapter 14.4.3.2, "Ionosphere grid settings" , on page 252.
27	SBAS service message	See "Service" on page 265.
28	Clock-Ephemeris covariance matrix message	See Chapter 14.4.3.7, "Clock-ephemeris covariance matrix configuration settings" , on page 260.
8 11 13 to 16 19 to 23 29 to 61	Reserved	- (not simulated)
0 62 63	For SBAS testing only Initial test message Null message	- (This message is filled in with empty timeslots depending on the transmit period values selected for the other message types.)

SBAS message scheduling

The SBAS messages are scheduled according to a user-defined period. The default values reflect the timeouts specified in the specification [RTCA MOPS DO-229](#).

Loading SBAS corrections

Similar to the constellation and navigation data files, you can load SBAS constellation and correction files, for example, to reproduce a specific situation from the past.

For details, see [Chapter 18.2, "Import SBAS settings"](#), on page 312.

Assigning SBAS space vehicles

The assignment of an SBAS space vehicle (PRN) to the corresponding regional augmentation system can change from time to time. You can assign up to six space vehi-

cles to one individual regional system, see ["Mapping SBAS space vehicles \(PRN\)"](#) on page 242. For related settings, see ["SBAS PRN Mapping"](#) on page 244.

14.2 About SBAS corrections

Applying SBAS corrections

Apply SBAS corrections, if you want to correct errors that result from errors of the simulated navigation message. These corrections result in a corrected broadcasted navigation message and improve simulation accuracy of the generated GNSS output signal.

SBAS corrections are not necessary, if the simulated navigation message and the broadcasted navigation messages match as they are (default configuration). Activating SBAS does not improve the positioning accuracy of the GNSS receiver. If, for example, the receiver under test does not support SBAS, you may observe a degradation of the positioning performance of the receiver.

SBAS error correction data source

By default, SBAS error correction uses the correction data as defined in the SBAS navigation message, see [Chapter 14.4, "SBAS settings"](#), on page 243.

Also, you can import SBAS correction data from *.nstrb, *.ems or Rinex files. Select the data source via "Import Constellation and Correction Data" in the satellite constellation settings of the SBAS, see [Chapter 14.4.1, "SBAS satellites settings"](#), on page 244.

Corrections are applied automatically for atmospheric delays and satellite biases (pseudorange and clock biases and satellite orbit errors).

Biases and corrections

The following corrections are applied automatically:

- $\Delta I_{\text{iono}_{\text{SV}}}$
Vertical delay values, according to the ionospheric grid, broadcasted in the SBAS messages
- $\Delta T_{\text{Tropo}_{\text{SV}}}$
Corrections, as defined by MOPS-DO-229D
- $\Delta \rho_{\text{SV}} = \Delta \rho_{\text{Fast_corrections}}$
Pseudorange bias corrections are the pseudorange corrections retrieved from the SBAS fast correction data ("PRC")
- $\Delta t_{\text{SV}} = \Delta t_{\text{clk}} + \Delta t_{\text{LT_corrections}}$
Clock corrections calculated as the sum of:
 - The clock bias broadcasted by the SV itself (Δt_{clk})
 - The corrections $\Delta t_{\text{LT_corrections}}$ retrieved from the SBAS long-term correction data ("δaf0", "δaf1")
- $\Delta x_{\text{LT_corrections}}$, $\Delta y_{\text{LT_corrections}}$, $\Delta z_{\text{LT_corrections}}$

Correction information on the GEO satellite location retrieved from the SBAS long-term correction data (" $\delta x/\delta y/\delta z$ ")

These corrections are used for the pseudorange and range calculations.

Pseudorange calculation

The pseudorange τ_{SV} is a function of the range ρ_{SV} and the corrections:

$$\tau_{SV} = \rho_{SV} + \Delta\rho_{SV} + \Delta I_{iono_{SV}} + \Delta T_{tropo_{SV}} - \Delta t_{SV}.$$

Where the range ρ_{SV} is:

$$\rho_{SV} = \sqrt{[(x_{RX} - x_{SV})^2 + (y_{RX} - y_{SV})^2 + (z_{RX} - z_{SV})^2]}$$

The SV position (x_{SV}, y_{SV}, z_{SV}) is the sum of the ephemeris position $(x_{eph}, y_{eph}, z_{eph})$ and the long-term corrections $(\Delta x_{LT_corrections}, \Delta y_{LT_corrections}, \Delta z_{LT_corrections})$, for example.

$$x_{SV} = x_{eph} + \Delta x_{LT_corrections}$$

SBAS correction impact on the logged data

SBAS corrects the pseudorange, satellites and receiver position values. If data logging is used, the logged values include the corrections. The logged data can deviate from the expected not corrected parameters.

14.3 How to generate SBAS corrections

Activating SBAS

1. Select "System Configuration" > "Systems & Signals".
2. To activate the frequency band, select "L# Band" > "On".
For SBAS, you can activate the L1 band and L5 band.
3. To activate the SBAS, select "SBAS" > "EGNOS/WASS/MSAS/GAGAN" > "On" as needed.

The figure below shows a configuration with activated L1 band and L5 band. Also GPS, EGNOS, WASS, MSAS and GAGAN system are activated.

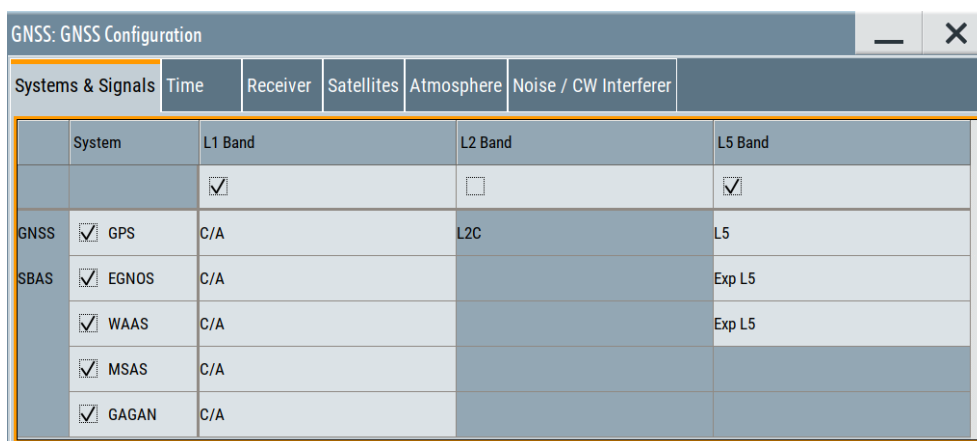

Mapping SBAS space vehicles (PRN)

This step-by-step instruction describes, how to map individual SBAS space vehicles ("PRN xyz") to the EGNOS SBAS. Mapping to other SBAS is analogous.

1. To activate EGNOS, see ["Activating SBAS"](#) on page 241.
2. Select "Satellites" > "SBAS" > "SBAS PRN Mapping".
The dialog "SBAS PRN Mapping" opens. It allows you to map SBAS space vehicles "PRN xyz" with SBAS systems.

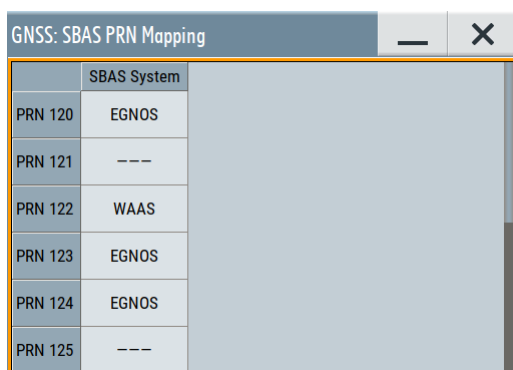

By default, SBAS space vehicles and SBAS systems are mapped as described in the table below.

SBAS	SV ID / PRN					
EGNOS	PRN 120	PRN 123	PRN 124	PRN 124	PRN 131	PRN 136
WAAS	PRN 122	PRN 133	PRN 134	PRN 135	PRN 138	---
MSAS	PRN 129	PRN 137	---	---	---	---
GAGAN	PRN 127	PRN 128	---	---	---	---

When changing the default mapping, note, that you can map a maximum of six space vehicles to an individual SBAS system.

3. To change the default mapping of EGNOS space vehicles, proceed as follows.

- a) Deselect space vehicles "PRN xyz", that you do not want to be part of the EGNOS constellation.
For "PRN 120", select, for example "SBAS System" > "---".
- b) Add space vehicles, that you want to include in the EGNOS constellation.
For "PRN 125", select, for example, "SBAS System" > "EGNOS".
If the EGNOS constellation already includes six space vehicles, you cannot select "EGNOS".

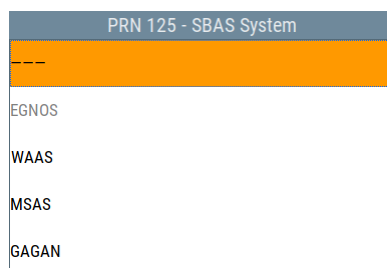

Applying real SBAS corrections

In the following, we use the default SBAS constellation and correction data. These corrections are real SBAS data, downloaded from the SBAS server and applicable to the default simulation time (2014-02-19).

1. Enable SBAS.
2. Select "Satellites > SBAS".

The SBAS corrections are configurable but the broadcast navigation message of the GPS satellites cannot be edited. Atmospheric models and pseudorange parameters are retrieved from the SBAS corrections and cannot be edited, too.

The default SBAS corrections augment the default clock and orbit parameters of the GPS satellites. If the simulated orbit and clock parameters are changed or pseudorange errors are defined, the SBAS corrections have to be adjusted manually.

3. Select "SBAS > SV ID > SV Config".
4. Select "Nav Msg Content > Config".

14.4 SBAS settings

The SBAS settings are distributed among several dialogs, depending on their type. The SBAS satellites settings, for example, are located in the similar dialogs as the settings of the GPS satellites. You access this dialog on the same way as you access the dialogs of the other GNSS systems.

Common settings are thus described in the corresponding sections; cross-references are provided wherever needed. This section focuses on the settings that are dedicated to SBAS.

For step-by-step description, see [Chapter 14.3, "How to generate SBAS corrections"](#), on page 241.

The remote commands required to define these settings are described in [Chapter 22.15, "SBAS corrections"](#), on page 574.

- [SBAS satellites settings](#)..... 244
- [GEO ranging information](#)..... 245
- [Differential corrections](#)..... 250
- [Additional SBAS system parameters](#)..... 261

14.4.1 SBAS satellites settings

Access:

1. Select "GNSS Configuration" > "Systems & Signals".
2. Select "SBAS" > "EGNOS/WASS/MSAS/GAGAN" > "On"
3. Select "Satellites" > "SBAS".

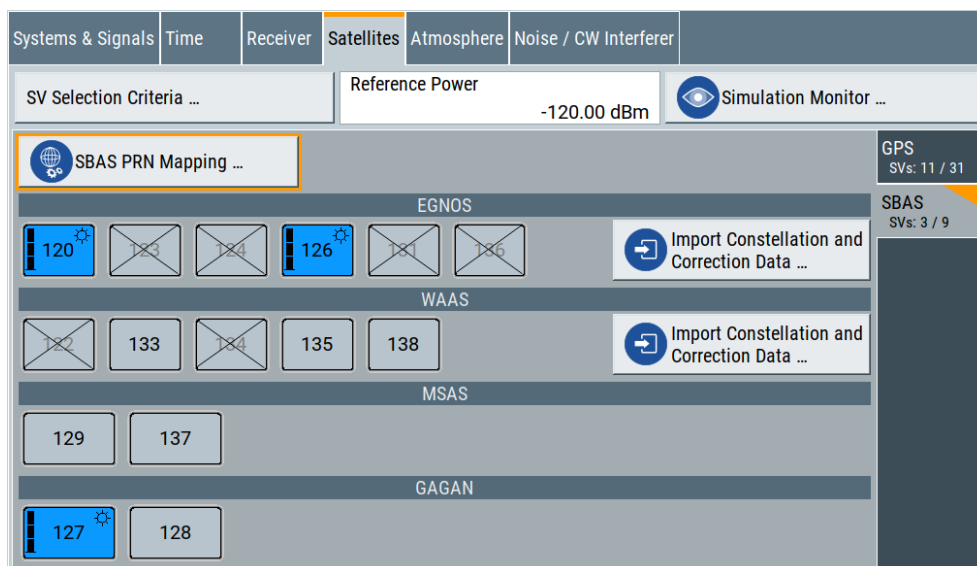

- [SBAS PRN Mapping](#)..... 244
 - ↳ [SBAS System](#)..... 245

SBAS PRN Mapping

Accesses the dialog "SBAS PRN Mapping" to map SBAS space vehicles "PRN xyz" with SBAS systems.

	SBAS System
PRN 120	EGNOS
PRN 121	---
PRN 122	WAAS
PRN 123	EGNOS
PRN 124	EGNOS
PRN 125	---

How to: ["Mapping SBAS space vehicles \(PRN\)"](#) on page 242

SBAS System ← SBAS PRN Mapping

Maps the SBAS space vehicle "PRN xyz" with the SBAS system.

"PRN xyz" ranges from "PRN 120" to "PRN 150", so that you can map each of the 39 space vehicles to one individual SBAS system. For an individual space vehicle, "SBAS System" > "---" means that this space vehicle is excluded from all SBAS constellations.

Remote command:

[\[:SOURCE<hw> \] :BB:GNSS:SVID<ch>:SBAS:SYSTEM](#) on page 578

14.4.2 GEO ranging information

The SBAS GEO satellites transmit GPS-L1-like signals to extend the number of visible satellites. The signals transmitted with this purpose are called ranging signals.

As for any other GNSS satellites, you can configure the simulated ranging information of the GEO satellites and, if necessary, change the broadcasted ranging information.

- [Simulated orbit and simulated clock settings](#)..... 245
- [Broadcasted orbit, clock and time conversion settings](#)..... 247

14.4.2.1 Simulated orbit and simulated clock settings

Access:

1. Select "System Configuration > Systems & Signals > SBAS (e.g. EGNOS) > On".
2. Select "Satellites > SBAS > SV ID# > SV Config > Simulated Orbit".

GNSS A: SV Configuration (EGNOS 120)			
Signals Config	Simulated Orbit	Simulated Clock	Pseudorange Errors
Reference Date	19.02.2014	Reference Time	06:00:00.000
X _G	40 636 720.00 m	Y _G	-11 245 916.00 m
Z _G			0.0 m
X _G Rate of Change	0.000 0 m/s	Y _G Rate of Change	0.000 0 m/s
Z _G Rate of Change			0.000 m/s
X _G Acceleration	0.000 00 m/s ²	Y _G Acceleration	0.000 00 m/s ²
Z _G Acceleration			0.000 00 m/s ²

3. Select "Satellites > SBAS > SV ID# > SV Config > Simulated Clock".

GNSS A: SV Configuration (EGNOS 120)			
Signals Config	Simulated Orbit	Simulated Clock	Pseudorange Errors
Reference Date	19.02.2014	Reference Time	06:00:00.000
a _{Gf0}	0.000 000 000 0	a _{Gf1}	0.000 000 000 000 0

Settings:

Ground Track..... 246
 Simulated Orbit..... 246
 Simulated Clock..... 247

Ground Track

Displays a plot of the trajectory of the selected satellite.

To observe the aggregated ground tracks of all satellites, select "GNSS > Simulation Monitor > Display = Satellites > Ground Track".

Simulated Orbit

Comprises the parameters of the EGNOS, WAAS, MSAS satellites.

Parameter	Remote command:
"Reference Date"	[:SOURCE<hw>] :BB:GNSS:SVID<ch>:SBAS:SIMulated:ORBit:DATE on page 485
"Reference Time"	[:SOURCE<hw>] :BB:GNSS:SVID<ch>:SBAS:SIMulated:ORBit:TIME on page 485
"X _G "	[:SOURCE<hw>] :BB:GNSS:SVID<ch>:SBAS:SIMulated:ORBit:XN on page 483
"Y _G "	[:SOURCE<hw>] :BB:GNSS:SVID<ch>:SBAS:SIMulated:ORBit:YN on page 483
"Z _G "	[:SOURCE<hw>] :BB:GNSS:SVID<ch>:SBAS:SIMulated:ORBit:ZN on page 483
"X _G Rate of Change"	[:SOURCE<hw>] :BB:GNSS:SVID<ch>:SBAS:SIMulated:ORBit:XDN on page 483

Parameter	Remote command:
"Y _G Rate of Change"	[:SOURCE<hw>] :BB:GNSS:SVID<ch>:SBAS:SIMulated:ORBit:YDN on page 483
"Z _G Rate of Change"	[:SOURCE<hw>] :BB:GNSS:SVID<ch>:SBAS:SIMulated:ORBit:ZDN on page 483
"X _G Acceleration"	[:SOURCE<hw>] :BB:GNSS:SVID<ch>:SBAS:SIMulated:ORBit:XDDN on page 484
"Y _G Acceleration"	[:SOURCE<hw>] :BB:GNSS:SVID<ch>:SBAS:SIMulated:ORBit:YDDN on page 484
"Z _G Acceleration"	[:SOURCE<hw>] :BB:GNSS:SVID<ch>:SBAS:SIMulated:ORBit:ZDDN on page 484

Simulated Clock

Comprises the parameters of the EGNOS, WAAS, MSAS satellites.

Parameter	Remote command:
"Reference Date"	[:SOURCE<hw>] :BB:GNSS:SVID<ch>:SBAS:SIMulated:CLOCK:DATE on page 485
"Reference Time"	[:SOURCE<hw>] :BB:GNSS:SVID<ch>:SBAS:SIMulated:CLOCK:TIME on page 485
"a _{Gf0} ", "a _{Gf1} "	[:SOURCE<hw>] :BB:GNSS:SVID<ch>:SBAS:SIMulated:CLOCK:AF<s2us0> on page 490

14.4.2.2 Broadcasted orbit, clock and time conversion settings

Access:

1. Select "System Configuration > Systems & Signals > SBAS (e.g. EGNOS) > On".
2. Select "Satellites > SBAS > Error Correction Mode > Replay Historical Data (and Sync Atmosphere & SV Errors)".
3. Select "SV# > SV Config > Signals Configuration".
4. Select "Nav Msg Control > Edit".
5. Select "Nav Msg Content > Config" > "Orbit".

GNSS A: Navigation Message NAV (EGNOS 120)						
Orbit	Clock	Additional Data	Time Conversion for All SVs	Ionosphere for All SVs	Differential Correction for All SVs	System Parameters for All SVs
Time of Day		280 768				
X _G	40 636 720.00 m	Y _G	-11 245 916.00 m		Z _G	0.0 m
X _G Rate of Change	0.000 0 m/s	Y _G Rate of Change	0.000 0 m/s		Z _G Rate of Change	0.000 m/s
X _G Acceleration	0.000 00 m/s ²	Y _G Acceleration	0.000 00 m/s ²		Z _G Acceleration	0.000 00 m/s ²
Show Scaled Values <input type="checkbox"/>						

6. Open the "Clock", "Time Conversion" and "Additional Data" setting in the same manner.

Per default, the navigation message parameters are set to values that correspond to the values retrieved from the constellation data source.

Settings:

Orbit..... 248

Clock..... 249

Additional Data..... 249

Time Conversion..... 249

Orbit

Comprises the parameters of the EGNOS/WAAS/MSAS satellites.

Parameter	Remote command:
"Time of Day"	[:SOURCE<hw>] :BB:GNSS:SVID<ch>:SBAS:NMESSAGE:NAV:EPHEMERIS:TOE on page 521
"X _G "	[:SOURCE<hw>] :BB:GNSS:SVID<ch>:SBAS:NMESSAGE:NAV:EPHEMERIS:YN on page 532
"Y _G "	[:SOURCE<hw>] :BB:GNSS:SVID<ch>:SBAS:NMESSAGE:NAV:EPHEMERIS:ZN on page 532
"Z _G "	[:SOURCE<hw>] :BB:GNSS:SVID<ch>:SBAS:NMESSAGE:NAV:EPHEMERIS:YDN on page 533
"X _G Rate of Change"	[:SOURCE<hw>] :BB:GNSS:SVID<ch>:SBAS:NMESSAGE:NAV:EPHEMERIS:ZDN on page 533
"Y _G Rate of Change"	[:SOURCE<hw>] :BB:GNSS:SVID<ch>:SBAS:NMESSAGE:NAV:EPHEMERIS:XDDN on page 534
"Z _G Rate of Change"	[:SOURCE<hw>] :BB:GNSS:SVID<ch>:SBAS:NMESSAGE:NAV:EPHEMERIS:YDDN on page 534
"X _G Acceleration"	[:SOURCE<hw>] :BB:GNSS:SVID<ch>:SBAS:NMESSAGE:NAV:EPHEMERIS:XDDN on page 534

Parameter	Remote command:
"Y _G Acceleration"	<code>[:SOURCE<hw>] :BB:GNSS:SVID<ch>:SBAS:NMESSage:NAV:EPHemeris:YDDN</code> on page 534
"Z _G Acceleration"	<code>[:SOURCE<hw>] :BB:GNSS:SVID<ch>:SBAS:NMESSage:NAV:EPHemeris:ZDDN</code> on page 534

Clock

Comprises the parameters of the EGNOS/WAAS/MSAS satellites.

Parameter	Remote command:
"a _{Gf0} ", "a _{Gf1} "	<code>[:SOURCE<hw>] :BB:GNSS:SVID<ch>:SBAS:NMESSage:NAV:CCORrection:AF<s2us0></code> on page 541

Additional Data

The "User Range Accuracy Index" (URA) indicates statistically the SBAS satellite ranging accuracy.

Satellites with "User Range Accuracy Index = 15", for example, are not used for position estimation.

Remote command:

`[:SOURCE<hw>] :BB:GNSS:SVID<ch>:SBAS:NMESSage:NAV:EPHemeris:URA`
on page 547

Time Conversion

Comprises the SBAS time conversion parameters.

Table 14-2: EGNOS - UTC

Parameter	Remote command:
"W _{Not} "	<code>[:SOURCE<hw>] :BB:GNSS:SV:SBAS:EGNOS:NMESSage:NAV:TIME:CONVersion:UTC:WNOT</code> on page 553
"T _{ot} "	<code>[:SOURCE<hw>] :BB:GNSS:SV:SBAS:EGNOS:NMESSage:NAV:TIME:CONVersion:UTC:TOT</code> on page 554
"A ₀ "	<code>[:SOURCE<hw>] :BB:GNSS:SV:SBAS:EGNOS:NMESSage:NAV:TIME:CONVersion:UTC:AZERo</code> on page 557
"A ₁ "	<code>[:SOURCE<hw>] :BB:GNSS:SV:SBAS:EGNOS:NMESSage:NAV:TIME:CONVersion:UTC:AONE</code> on page 556

Table 14-3: GAGAN - UTC

Parameter	Remote command:
"W _{Not} "	<code>[:SOURCE<hw>] :BB:GNSS:SV:SBAS:GAGAN:NMESSage:NAV:TIME:CONVersion:UTC:WNOT</code> on page 553
"T _{ot} "	<code>[:SOURCE<hw>] :BB:GNSS:SV:SBAS:GAGAN:NMESSage:NAV:TIME:CONVersion:UTC:TOT</code> on page 554

Parameter	Remote command:
"A ₀ "	[:SOURCE<hw>] :BB:GNSS:SV:SBAS:GAGAN:NMESSage:NAV:TIME:CONVersion:UTC:AZERo on page 557
"A ₁ "	[:SOURCE<hw>] :BB:GNSS:SV:SBAS:GAGAN:NMESSage:NAV:TIME:CONVersion:UTC:AONE on page 556

Table 14-4: MSAS - UTC

Parameter	Remote command:
"W _{Not} "	[:SOURCE<hw>] :BB:GNSS:SV:SBAS:MSAS:NMESSage:NAV:TIME:CONVersion:UTC:WNOT on page 553
"T _{ot} "	[:SOURCE<hw>] :BB:GNSS:SV:SBAS:MSAS:NMESSage:NAV:TIME:CONVersion:UTC:TOT on page 554
"A ₀ "	[:SOURCE<hw>] :BB:GNSS:SV:SBAS:MSAS:NMESSage:NAV:TIME:CONVersion:UTC:AZERo on page 557
"A ₁ "	[:SOURCE<hw>] :BB:GNSS:SV:SBAS:MSAS:NMESSage:NAV:TIME:CONVersion:UTC:AONE on page 556

Table 14-5: WAAS - UTC

Parameter	Remote command:
"W _{Not} "	[:SOURCE<hw>] :BB:GNSS:SV:SBAS:WAAS:NMESSage:NAV:TIME:CONVersion:UTC:WNOT on page 553
"T _{ot} "	[:SOURCE<hw>] :BB:GNSS:SV:SBAS:WAAS:NMESSage:NAV:TIME:CONVersion:UTC:TOT on page 554
"A ₀ "	[:SOURCE<hw>] :BB:GNSS:SV:SBAS:WAAS:NMESSage:NAV:TIME:CONVersion:UTC:AZERo on page 557
"A ₁ "	[:SOURCE<hw>] :BB:GNSS:SV:SBAS:WAAS:NMESSage:NAV:TIME:CONVersion:UTC:AONE on page 556

14.4.3 Differential corrections

The SBAS GEO satellites broadcast additional correction data, known as differential corrections, to the existing GNSS navigation messages to improve the positioning accuracy. The differential corrections include corrections for the satellite orbits and clocks, and ionospheric corrections.

- [Timing setting of the differential corrections](#).....251
- [Ionosphere grid settings](#).....252
- [PRN mask settings](#).....254
- [Fast correction settings](#).....255
- [Long-term correction file configuration settings](#).....258
- [Fast correction degradation factor configuration settings](#).....259
- [Clock-ephemeris covariance matrix configuration settings](#).....260

14.4.3.1 Timing setting of the differential corrections

Navigation and correction data are time-specific information and the SBAS parameters are defined for a specific time span. In this implementation, the SBAS corrections are valid for 24 hours and this time span is repeated infinitely. Projection mechanism ensures that you can select any simulation date.

Time span

There is a time slider in each SBAS dialog. With this time slider, you can "scroll" over the time and edit, for example, the correction data at a particular time. The time span is displayed as a gray time bar with its start and end time. The orange bar indicates the current time span for that the SBAS parameters apply.



Figure 14-1: Timing settings

Use the following functions to define the SBAS parameters for a specific time span:

- Set the "Time Select" value to define the start time (and the time span) the SBAS parameters apply for.
- Insert a page to split the time span and define parameter changes at more precise time granularity.

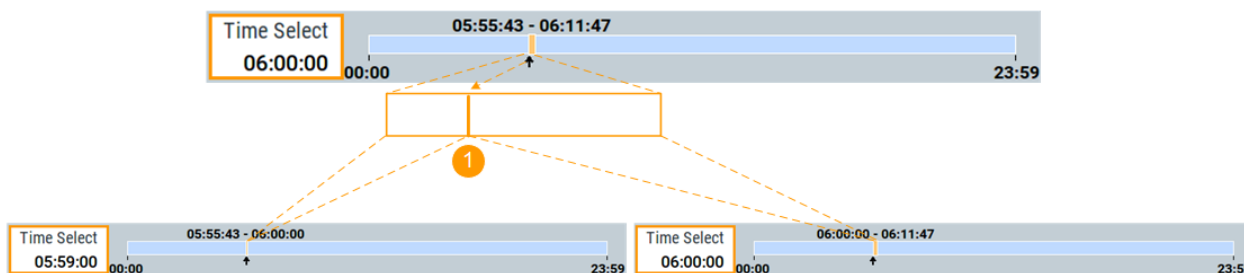

1 = "Time Select" defines the page split edge

- Remove pages to merge correction data

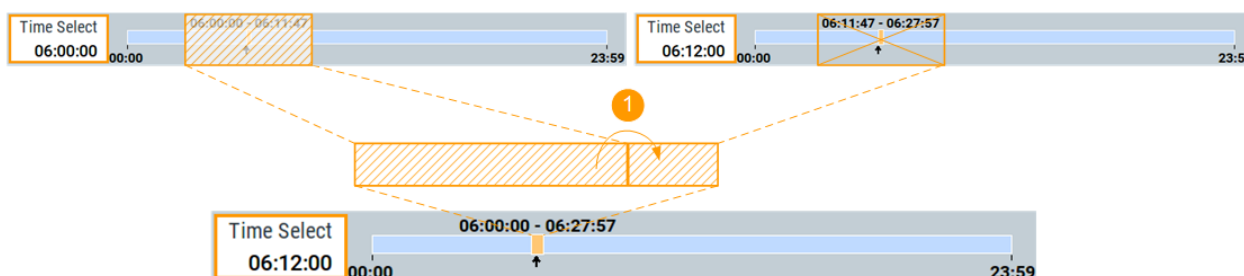

1 = "Time Select" defines the merge edge

Settings:

Insert/Delete Page..... 252
 Time Scale, Time Select.....252

Insert/Delete Page

"Insert Page" splits the current page at the current "Time Select" moment.

"Delete Page" removes the current page; the time span of the previous page is extended and the content of the new page corresponds to the content of the previous page.

Time Scale, Time Select

Displays a time scale (the gray bar) and the current time span (the orange bar).

An arrow indicates the current time ("Time Select").

Projection mechanism ensures that you can select any simulation date. Hence, date information is irrelevant and not displayed.

14.4.3.2 Ionosphere grid settings

Access:

1. Select "System Configuration > Systems & Signals > SBAS (e.g. EGNOS) > On".
2. Select "Satellites > SBAS > Error Correction Mode > Replay Historical Data (and Sync Atmosphere & SV Errors)".
3. Select "SV# > SV Config > Signals Configuration".
4. Select "Nav Msg Control > Edit".
5. Select "Nav Msg Content > Config" > **"Ionosphere"**.

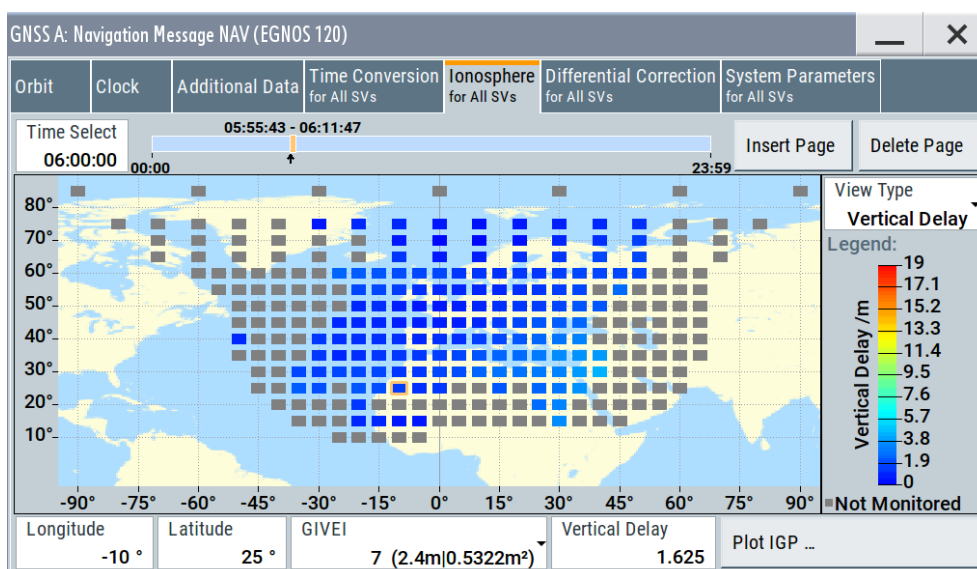

The ionospheric grid contains the ionospheric delay correction parameters of MT 26. It also contains the ionospheric grid mask of MT 18, that is the grid of all monitored squares.

MT 26 carries information on the vertical delays and their accuracy (σ^2_{GIVE}) at geographically defined ionospheric grid points (IGP).

The "GIVEI" and "Vertical Delay" values are displayed as a color-coded grid. Not monitored (NM) IGPs are indicated in gray.

Settings:

Longitude, Latitude.....253
 GIVEI/Vertical Delay.....253
 View Type.....253
 Plot Vertical Delays/Plot IGP.....253

Longitude, Latitude

Indicates the geographic coordinated of the selected ionospheric grid point IGP.

GIVEI/Vertical Delay

Sets the grid ionospheric vertical error indicator "GIVEI" and the "Vertical Delay" values of the current IGP.

Changes are applied immediately.

To save the ionospheric grid, select "Export Grid".

To restore the predefined ionospheric grid for the MOPS-DO-229 model, select "Import Grid > Add File > Predefined Files > 19_02_14_mixed > Import".

View Type

Toggles between indication of the vertical delay and GIVEI values.

Remote command:

```
[ :SOURce<hw> ] :BB:GNSS:ATMospheric:IONospheric:MOPS:DISPlay
```

on page 431

Plot Vertical Delays/Plot IGP

Displays the 24h vertical delay or GIVEI distribution functions.

Access: select a particular position on the "Ionospheric Grid" map and select "Plot IGP".

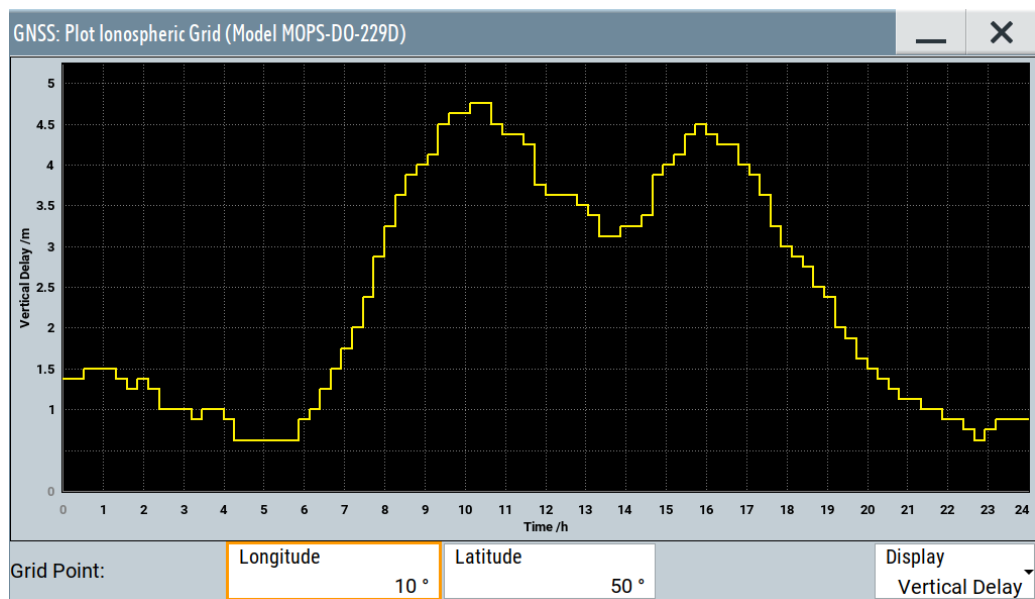

Figure 14-2: Example: 24h vertical delay distribution for a given position (the curve shows the MOPS-DO-229D distribution)

"Longitude, Latitude"

Scrolls between the grid points.

"Display"

Toggles between indication of the vertical delay and GIVEI values. The plot displays the variation of these values over a 24-hour time period.

14.4.3.3 PRN mask settings

Access:

1. Select "System Configuration > Systems & Signals > SBAS (e.g. EGNOS) > On".
2. Select "Satellites > SBAS > Error Correction Mode > Replay Historical Data (and Sync Atmosphere & SV Errors)".
3. Select "SV# > SV Config > Signals Configuration".
4. Select "Nav Msg Control > Edit".

5. Select "Nav Msg Content > Config" > "Differential Corrections".

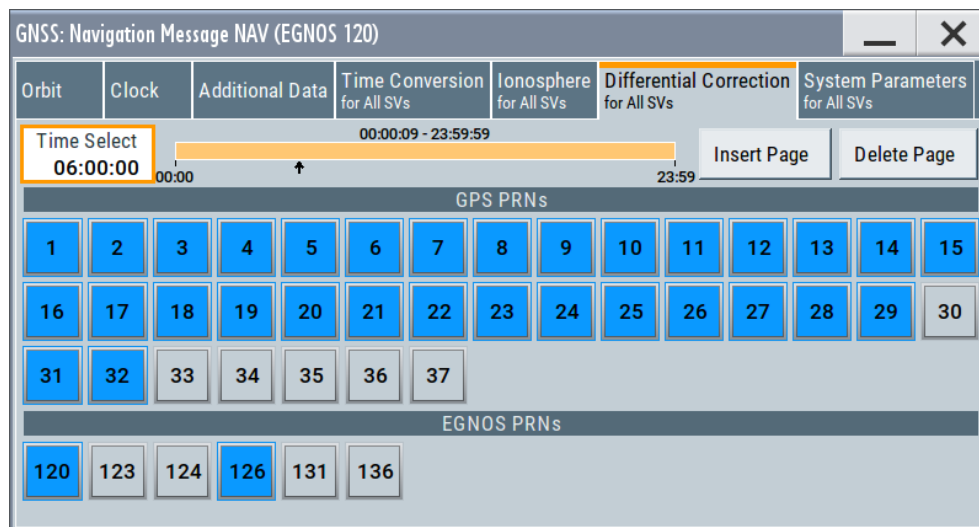

The PRN mask is a list of the SVs for which the fast and long-term correction data apply.

Settings:

[GNSS PRNs/SBAS PRNs, State](#)..... 255

GNSS PRNs/SBAS PRNs, State

To enable an SV ID/PRN: select it and select "State > On".

Up to 51 satellites can be enabled, where an enabled satellite is indicated with blue color.

It is, however, not necessary to change the PRN mask because currently, only GPS and SBAS satellites are monitored; EGNOS and WAAS do not change the PRN mask. In the future, when more GNSS systems are augmented, changing the PRN mask would be necessary to define the 51 monitored SV ID/PRNs.

Remote command:

[:SOURCE<hw>] :BB:GNSS:SYSTEM:SBAS:EGNOS:NMESsage:NAV:PRN<ch>: STATE on page 578

14.4.3.4 Fast correction settings

Access:

1. Select "System Configuration > Systems & Signals > SBAS (e.g. EGNOS) > On".
2. Select "Satellites > SBAS > Error Correction Mode > Replay Historical Data (and Sync Atmosphere & SV Errors)".
3. Select "SV# > SV Config > Signals Configuration".
4. Select "Nav Msg Control > Edit".

5. Select "Nav Msg Content > Config" > "Differential Corrections".

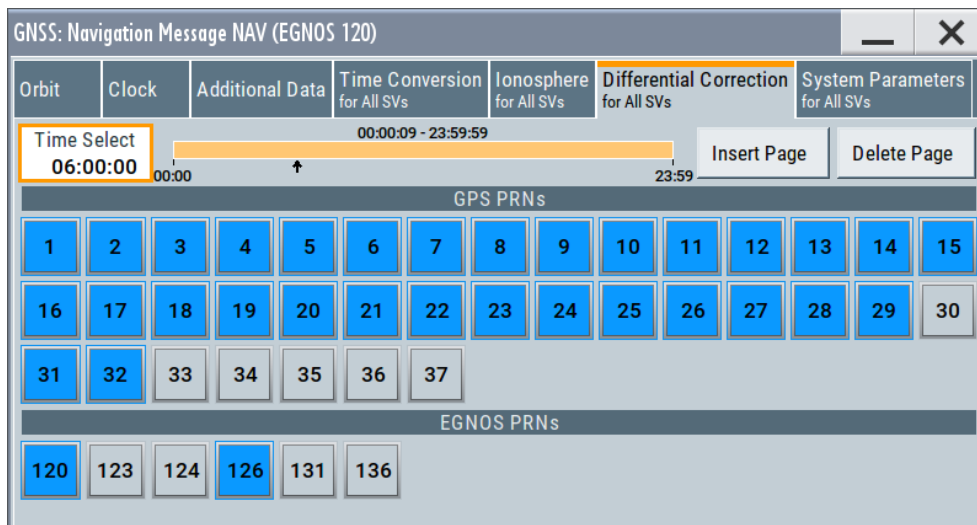

SBAS differential corrections augment only the GPS satellites. The "Differential Corrections" displays all GPS SV IDs (or PRNs) for that correction data is available.

6. Select "PRN > State > On" to enable transmission of correction data for the particular satellite.

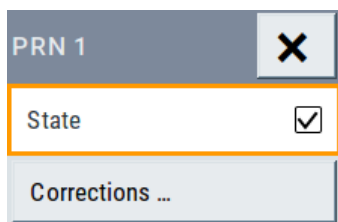

7. To configure the differential corrections, select "PRN > Corrections > Fast Corrections".

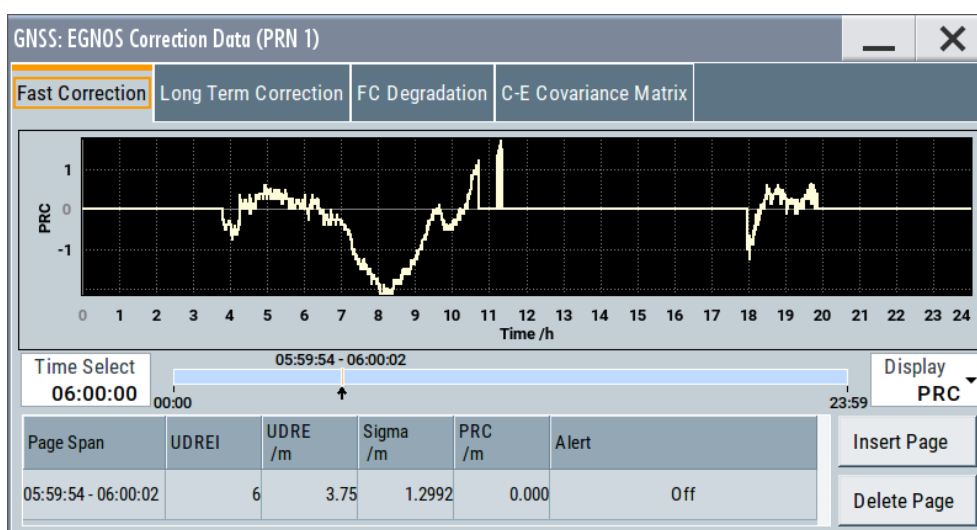

The fast corrections contain the fast correction parameters of MT 2, 3, 4 and 5.

The four messages MT 2, 3, 4 and 5 carry information on the following:

- The issue of data fast correction (IODF)
- User Differential Range Error Indicator (UDREI) and the UDRE
- The coarse integrity "use/don't use" alarm ("Alert" flag)
- The Pseudo Range Correction (PRC) per PRN for a set of up to 13 PRNs

Table 14-6: UDRE, σ^2_{UDRE} and GPS URA as a function of UDREI

UDREI	UDRE, m	σ^2_{UDRE} , m ²	GPS URA*
0	0.75	0.0520	2
1	1.0	0.0924	2
2	1.25	0.1444	2
3	1.75	0.2830	2
4	2.25	0.4678	2
5	3.0	0.8315	3
6	3.75	1.2992	3
7	4.5	1.8709	4
8	5.25	2.5465	5
9	6.0	3.3260	5
10	7.5	5.1968	5
11	15.0	20.7870	15
12	50.0	230.9661	10
13	150	2078.695	11
14	not monitored ("NM")	not monitored ("NM")	5** (average accuracy)
15	Do not use ("DNU")	Do not use ("DNU")	15 Do not use ("DNU")

*) If "Error Correction Mode = Replay Historical Data and Sync Atmosphere & SV Errors" is enabled, the GPS URA values are automatically set.

**) for UDREI = 14 (not monitored), the GPS URA value is set to average accuracy, i.e. URA = 5.

Settings:

Display..... 257
 Fast Correction Data Parameters..... 258

Display

Sets the parameter whose variation over the 24-hour time period is indicated on the plot.

Fast Correction Data Parameters

Sets the fast correction data parameters per PRN.

- "UDREI" User Differential Range Error Indicator
- "UDRE" User Differential Range Error value
- "Sigma" UDRE accuracy σ^2_{UDRE} , see [Table 14-6](#).
- "PRC" Pseudo Range Corrections
- "Alert" If enabled, simulates a short-term alarm, i.e. a coarse integrity "don't use" information.

14.4.3.5 Long-term correction file configuration settings

Access:

1. Select "Satellites > SBAS > Error Correction Mode > Replay Historical Data (and Sync Atmosphere & SV Errors)".
2. Select "SV# > SV Config > Signals Configuration > Nav Msg Content > Config > Differential Corrections".
3. For a PRN, select "**PRN > Configuration > Long Term Corrections**".

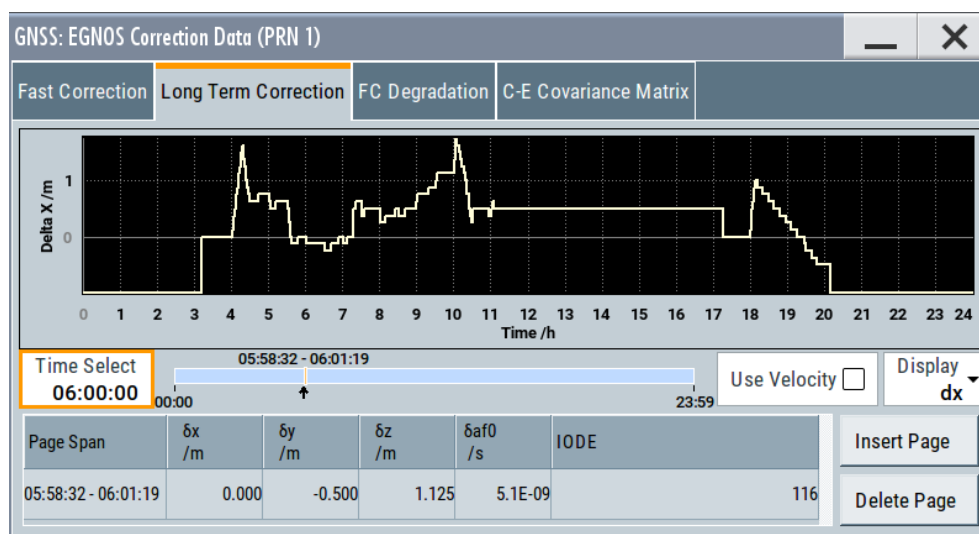

The long-term corrections contain the fast correction parameters of MT 1, 24 and 25.

MT 25 and the long-term data set part of MT 24 carry error estimates for slow varying satellite ephemeris (SV location) and clock errors, including velocity and drift errors.

Settings:

- [Use Velocity](#)..... 259
- [Display](#)..... 259
- [Long Term Correction Data Parameters](#)..... 259

Use Velocity

Enables signaling of the velocity and clock drift errors.

Display

Sets the parameter whose variation over the 24-hour time period is indicated on the plot.

Long Term Correction Data Parameters

Sets the long-term correction data parameters per PRN.

" $\delta x/\delta y/\delta z$, m" Correction information on the GEO satellite location in WGS-84 coordinates.

" $\delta af0$, s" Clock offset error correction

"IODE" Issue of Data Ephemeris (IODE)

Note: The IOD must match the IODC and IODE in the navigation message of the GPS satellite.

To automatically synchronize the required values and ensure integrity, select "Error Correction Mode = Replay Historical Data and Sync Atmosphere & SV Errors".

" $\delta x'/\delta y'/\delta z'$ " Rate of change correction vector
If the "Use Velocity > Off", the rate of change vector is set to 0.

" $\delta af1$ " Clock drift error correction.

"TOD" Time of Day, i.e. the time span for that the " $\delta x'/\delta y'/\delta z'$ " and " $\delta af1$ " are applied.

14.4.3.6 Fast correction degradation factor configuration settings

Access:

1. Select "Satellites > SBAS > Error Correction Mode > Replay Historical Data (and Sync Atmosphere & SV Errors)".
2. Select "SV# > SV Config > Signals Configuration > Nav Msg Content > Config > Differential Corrections".
3. For a PRN, select "**PRN > Configuration > FC Degradation**".

The fast correction degradation factor ("a"), the applicable IODP and the system latency time (t_{lat}) are carried by the MT 7.

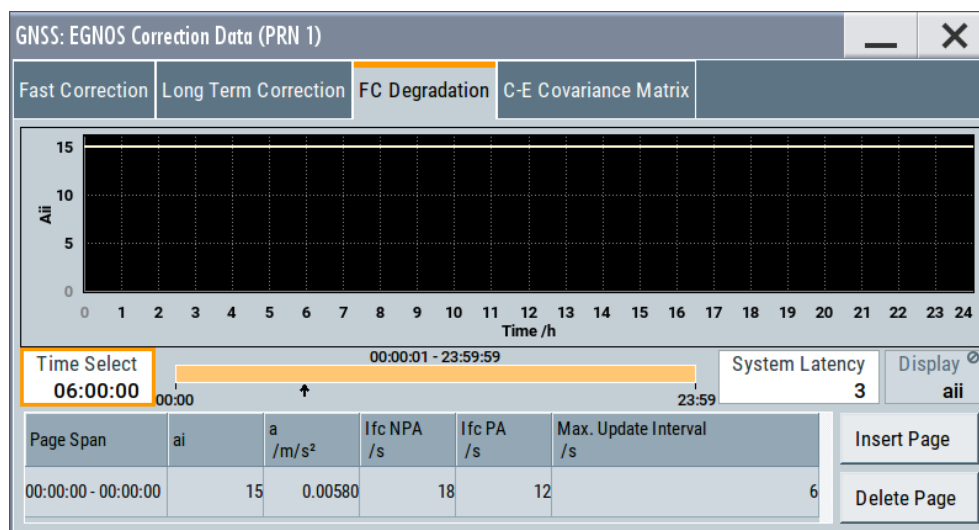

Settings:

- System Latency.....260
- Display..... 260
- Fast Correction Degradation Factor Parameters..... 260

System Latency

Sets the system latency time t_{lat} .

Display

Sets the parameter whose variation over the 24-hour time period is indicated on the plot.

Fast Correction Degradation Factor Parameters

Sets the fast correction degradation factor per PRN.

- " a_i " Fast correction degradation factor indicator
This value of this parameter determines the values of the other degradation parameters.
- "a, m/s²" Fast correction degradation factor.
- " l_{fc} NPA, s" User timeout interval, En-route through LANV Approach.
- " l_{fc} PA, s" User timeout interval, En-route through LANV/VAN, LV, LP Approach.
- "Max. update interval, s"
Maximum fast correction update interval.

14.4.3.7 Clock-ephemeris covariance matrix configuration settings

Access:

1. Select "Satellites > SBAS > Error Correction Mode > Replay Historical Data (and Sync Atmosphere & SV Errors)".

2. Select "SV# > SV Config > Signals Configuration > Nav Msg Content > Config > Differential Corrections".
3. For a PRN, select "**PRN > Configuration > C-E Covariance Matrix**".

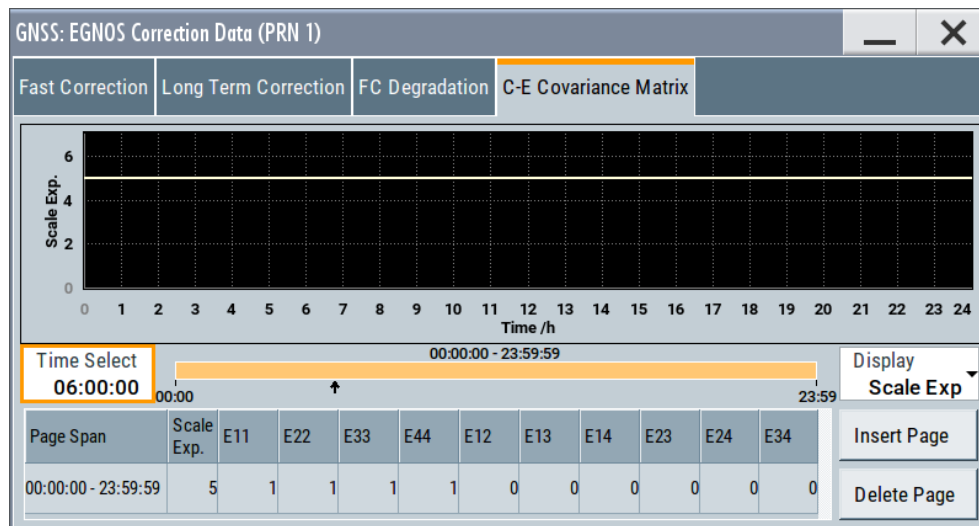

The relative covariance matrix for clock and ephemeris errors is transmitted by MT 28.

Settings:

- Display..... 261
- Clock-Ephemeris Covariance Matrix Elements.....261

Display

Sets the parameter whose variation over the 24-hour time period is indicated on the plot.

Clock-Ephemeris Covariance Matrix Elements

Sets the Clock-Ephemeris covariance matrix elements per PRN.

"Scale Exp." Scale exponent

"E11, E22, ... E44"

10 non-zero elements $E_{1,1}$ to $E_{4,4}$ of the covariance matrix.

14.4.4 Additional SBAS system parameters

Access:

1. Select "System Configuration > Systems & Signals > SBAS (e.g. EGNOS) > On".
2. Select "Satellites > SBAS > Error Correction Mode > Replay Historical Data (and Sync Atmosphere & SV Errors)".
3. Select "SV# > SV Config > Signals Configuration".

4. Select "Nav Msg Control > Edit".
5. Select "Nav Msg Content > Config" > **"System Parameters"** > "Message Schedule".

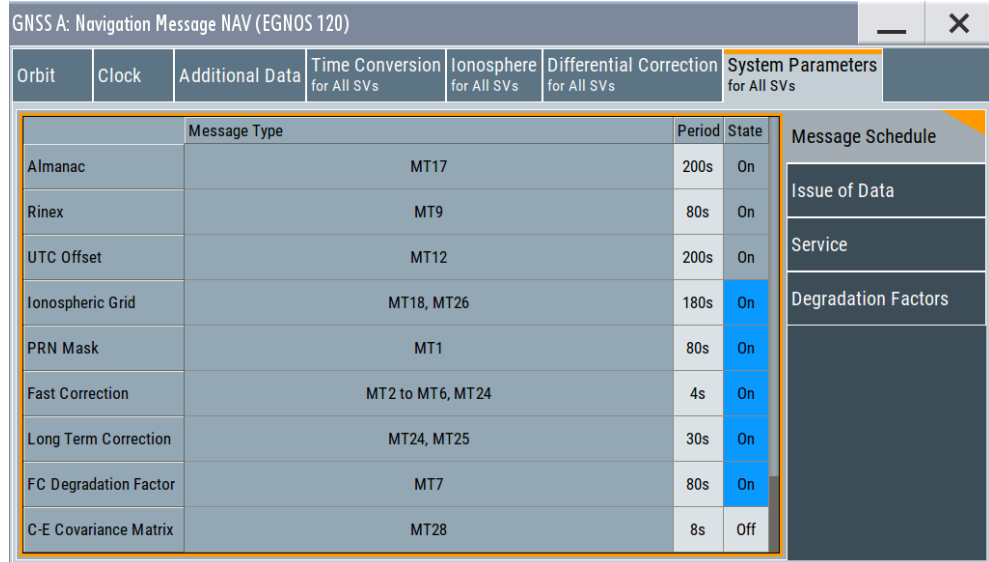

In this dialog, you select which SBAS messages are generated.

6. Select "System Parameters > Issue of Data".

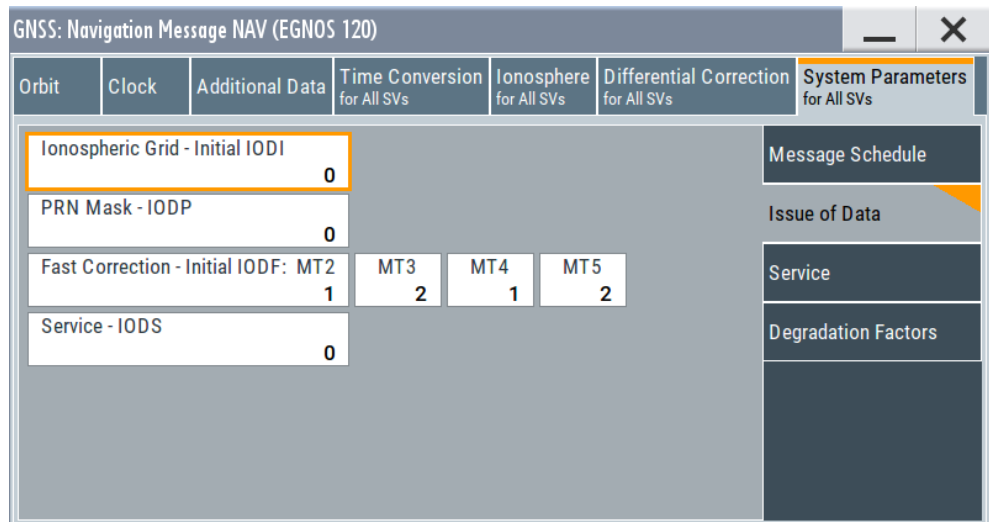

The dialog list the issue of data-related parameters of all differential correction types.

7. Select "System Parameters > Service".

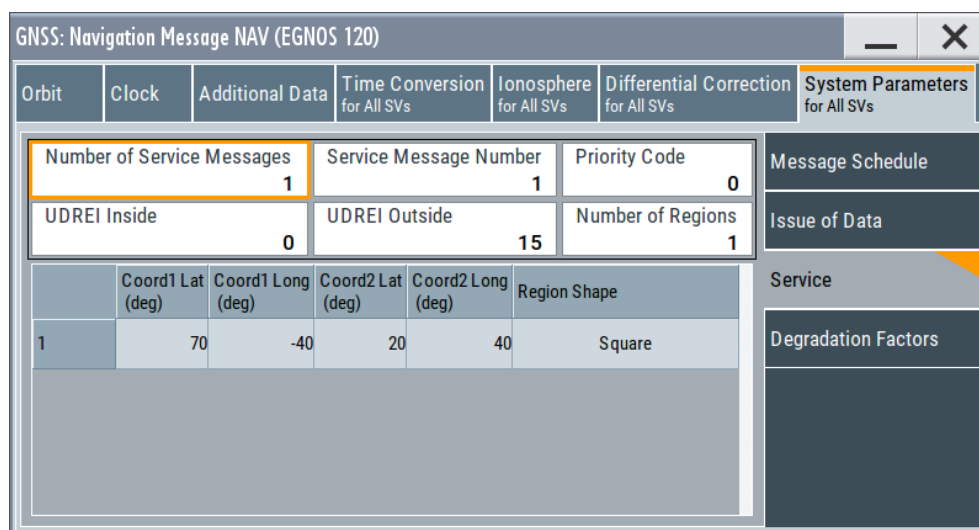

The service information is transmitted by MT 27.

8. Select "System Parameters > Degradation Factors".

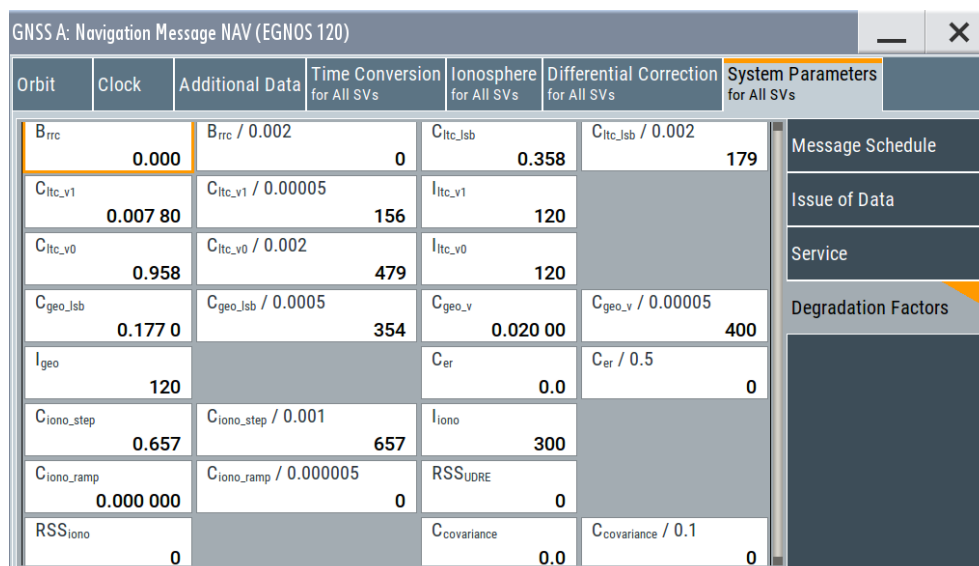

The dialog comprises the optional global degradation factors as specified in RTCA MOPS DO-229. The degradation factors are broadcasted in MT 10.

Settings:

- Message Schedule.....264
- Issue of Data.....264
 - L Ionospheric Grid - IODI.....264
 - L PRN Mask - IODP.....265
 - L Fast Correction - IODF.....265
 - L Service - IODS.....265
- Service.....265
 - L Number of Service Messages.....265
 - L Service Message Number.....265

L Priority Code.....	265
L UDREI Inside/Outside.....	265
L Number of Regions.....	265
L Coordinates and shape of each of up to five regions.....	265
Degradation Factors.....	265
L B_rrc.....	265
L C_ltc_v1, C_ltc_lsb, I_ltc_v1, C_ltc_v0, I_ltc_v0.....	265
L I_geo, C_geo_lsb, C_geo_v.....	266
L C_er.....	266
L RSS_iono, C_iono_step, C_geo_v, I_iono.....	266
L RSS_UDRE.....	266
L C_covariance.....	266

Message Schedule

The message schedule is a list of the SBAS messages that are generated.

Each SBAS message type is defined with:

"SBAS message content"	Indicates content of the SBAS message type.
"Message Type"	Indicates the SBAS message type according to RTCA MOPS DO-229
"State"	Enables generation of the particular SBAS correction data. Almanac and RINEX files, and UTC offset information are required for the navigation services of SBAS and are always enabled. Remote command: <code>[:SOURCE<hw>] :BB:GNSS:SYSTEM:SBAS:EGNOS:NMESSAGE:NAV:ALMANAC:STATE</code> on page 581
"Period"	Sets the periodicity of the SBAS message, i.e. the time interval after that a message is retransmitted. The selected value must not exceed the timeout specified in the specification RTCA MOPS DO-229 . Remote command: <code>[:SOURCE<hw>] :BB:GNSS:SYSTEM:SBAS:EGNOS:NMESSAGE:NAV:ALMANAC:PERIOD</code> on page 583

Issue of Data

Access: "System Parameters > Issue of Data".

The dialog lists the issue of data (IOD) related parameters of the differential correction types. The IOD values are retrieved from the predefined or the loaded correction data, see [Chapter 18.2, "Import SBAS settings"](#), on page 312.

Ionospheric Grid - IODI ← Issue of Data

Sets the *initial* Issue of Data ionospheric mask. The IOD is the incremental identifier of the transmission.

The IODI is internally increased every 240 seconds with the transmission of each page.

PRN Mask - IODP ← Issue of Data

Sets the Issue of Data PRN mask parameter.

Fast Correction - IODF ← Issue of Data

Sets the issue of data fast correction IODF, per message type.

Service - IODS ← Issue of Data

Sets the Issue of Data, Service.

Service

Access: "System Parameters > Service".

Comprises the service information as transmitted by MT 27.

Number of Service Messages ← Service

Defines the total number of unique Type 27 messages for the selected "IDOS".

Service Message Number ← Service

Sequential number that indicates a service message.

Priority Code ← Service

If the regions defined in more than messages overlap, this parameter indicates the message priority. The UDREI values specified in the service message with higher priority are used.

UDREI Inside/Outside ← Service

Specifies the δ UDREI factors.

The "UDREI Inside" factor applies on users within any of the specified regions; the "UDREI Outside", to the users that are outside.

See "[Coordinates and shape of each of up to five regions](#)" on page 265.

Number of Regions ← Service

Sets the number of geographic regions.

Coordinates and shape of each of up to five regions ← Service

Geographic regions are closed polygons, described with their shape ("Triangular" or "Square") and the coordinates ("Latitude" and "Longitude") of the corners.

Degradation Factors

Access: "System Parameters > Degradation Factors".

Degradation factors are optional global SBAS parameters and are defined in [RTCA MOPS DO-229](#). The degradation factors are broadcasted in MT 10.

B_rrc ← Degradation Factors

Sets the range-rate correction degradation parameter B_{rrc} .

C_ltc_v1, C_ltc_lsb, I_ltc_v1, C_ltc_v0, I_ltc_v0 ← Degradation Factors

Set the degradation parameters for long-term correction:

- " $I_{l_{tc_v1}}$, $C_{l_{tc_v1}}$,
 $C_{l_{tc_lsb}}$ " Apply if both offset and velocity are included in the messages (that is MT 24 and MT 25 with [Use Velocity](#) = "On").
- " $I_{l_{tc_v0}}$, $C_{l_{tc_v0}}$ " Apply if only offset is included in the messages (i.e. Velocity Code = 0).

I_{geo} , C_{geo_lsb} , C_{geo_v} ← Degradation Factors

Set the degradation parameters for GEO navigation message data I_{geo} , C_{geo_lsb} and C_{geo_v} .

C_{er} ← Degradation Factors

Sets the extra "catch-all" degradation parameter C_{er} .

RSS_{iono} , C_{iono_step} , C_{geo_v} , I_{iono} ← Degradation Factors

Define the degradation of the ionospheric corrections, as a function of:

- " RSS_{iono} " The root-sum-square flag.
- " C_{iono_ramp} , I_{iono} " The rate of change and the minimum update interval for ionospheric corrections.
- " C_{iono_step} " The bound on difference between successive ionospheric grid delay values.

RSS_{UDRE} ← Degradation Factors

Sets the root-sum-square flag RSS_{UDRE} , necessary to calculate the fast and long-term correction degradation.

$C_{covariance}$ ← Degradation Factors

Sets the degradation factor $C_{covariance}$, necessary to calculate the additional term ϵ_c that is broadcasted in MT 28.

15 Advanced GNSS scenarios

Additional to multi-constellation and multi-GNSS scenarios, the R&S SMW200A offers simulation of advanced GNSS scenarios. Equipped as a wideband instrument (R&S SMW-B9), the R&S SMW200A provides enhanced simulation capabilities of the output GNSS signal by the following:

- Simulation of up to two vehicles
- Simulation of several antennas: Up to six antennas
- Simulation of composite multi-GNSS and multi-RF band (multifrequency) signals
- Enhanced simulation capacity:
 - Up to 612 GNSS channels for a standard GNSS simulator.
See also [Chapter G, "Channel budget"](#), on page 682.
 - Up to 408 GNSS channels for a standard GNSS simulator with additional simulation of real-time kinematics.
See also ["Key features"](#) on page 152.

Due to limited bandwidth f_{BW} of the narrowband instrument ($f_{BW} \leq 160$ MHz), we recommend that you install option R&S SMW-B9 to simulate complex composite GNSS signals.

To simulate such complex GNSS signals, GNSS advanced mode uses the concept of GNSS streams.

GNSS stream

GNSS streams are logical units that describe the combination of vehicle, antenna and RF band used for the composite GNSS signal. In the figure below, for example, GNSS stream 1 relates to GNSS signals for vehicle 1 ("V1"), antenna 1 ("A1") and RF band "L1".

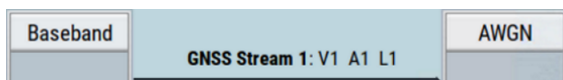

Depending on the installed options, you can configure up to 6 GNSS streams. Different GNSS streams can be mapped onto the same RF connector to output a complex GNSS signal. To simplify configuration, you can define GNSS stream composition and signal routing in a mapping table, see ["Output stream-mapping table"](#) on page 286.

A GNSS stream consists of GNSS channels.

GNSS channel

A GNSS channel refers to a hardware unit that is required to process and generate a GNSS signal. GNSS channels are uniquely composed of the following configuration elements: One vehicle/receiver, one antenna, one RF band and one signal of a single satellite.

Common baseband source

In advanced mode, there is only one baseband source to configure, which speeds up configuration and simplifies signal routing. In the baseband domain, configure the satellite constellation once. The constellation settings are imposed on individual conditions like multipath effects of multiple vehicles or antennas. The difference in the conditions results from the individual receiver's position, receiver type and antenna pattern.



Baseband allocation, GNSS stream composition and signal routing via the GNSS streams to the output connectors is performed automatically to allocate as many baseband resources as possible.

However, you can also define the number of GNSS streams and stream/signal routing to the output connectors. Further configuration, like for example adjusting the timing settings, changing the satellites constellation or defining atmospheric effects, are applied as for the standard GNSS configuration.

The following sections illustrate how to work with GNSS advanced mode and provide settings related to GNSS advanced mode. The last section provides information on settings related to GNSS streams and signal routing or stream routing to the outputs of the R&S SMW200A.

15.1 How to set up advanced GNSS scenarios

This chapter provides required options and configuration procedures for setting up advanced GNSS scenarios and configuring GNSS streams. The procedures comprise a different number of RF bands, vehicles, antennas and GNSS streams.

Changing the parameters implies a reconfiguration of the block diagram, in the "I/Q Stream Mapper" dialog and the "Output Streams" tab. The reconfiguration is performed automatically to allocate as many baseband sources as possible for the current configuration.

- [How to enable GNSS advanced mode](#)..... 268
- [How to set up multifrequency scenarios](#)..... 270
- [How to set up multi-vehicle scenarios](#).....275
- [How to set up multi-antenna scenarios](#).....276
- [How to configure GNSS streams](#)..... 278

15.1.1 How to enable GNSS advanced mode

Required options

The table below illustrates a minimum configuration to work with GNSS advanced mode.

Table 15-1: Advanced mode with R&S SMW-B9

Option	Designation	Remark
R&S SMW-B9	Wideband baseband generator	Two options are installable, one per signal path
R&S SMW-B13XT	Wideband main module	-
R&S SMW-K<x> ¹⁾	GNSS system option	Two options are installable, one per signal path

¹⁾ K<x> denotes a GNSS system option: R&S SMW-K44/K66/K94/K97/K98/K107/K132
 See also [Chapter 2.1, "Required options"](#), on page 17.

To enable GNSS advanced mode

1. In the block diagram, select "System Config" > "System Configuration" > "Fading/ Baseband Configuration".
2. Select "Mode" > "GNSS Advanced".

The preview diagram indicates the configuration and provides information on its common application fields.

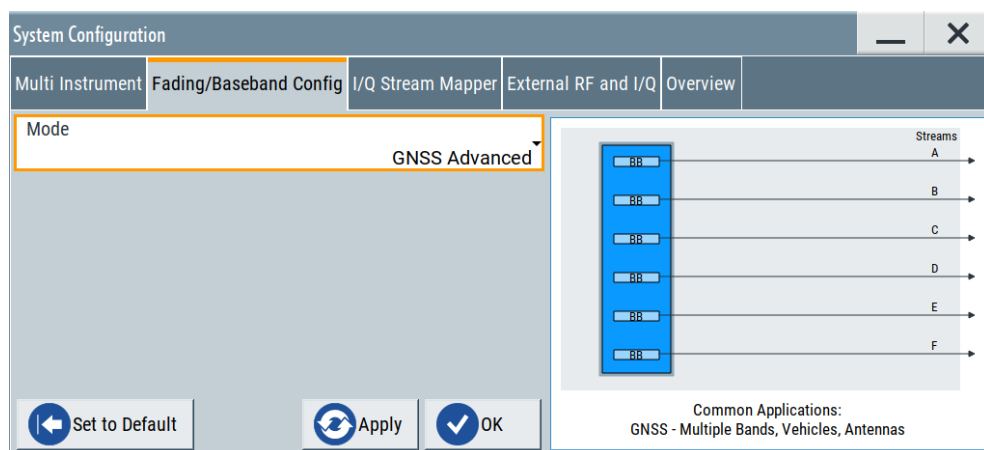

3. Confirm with "Apply" and "OK".

The block diagram transforms and indicates schematically that the GNSS signal is configured in one common baseband block. See also "Common baseband source" on page 268.

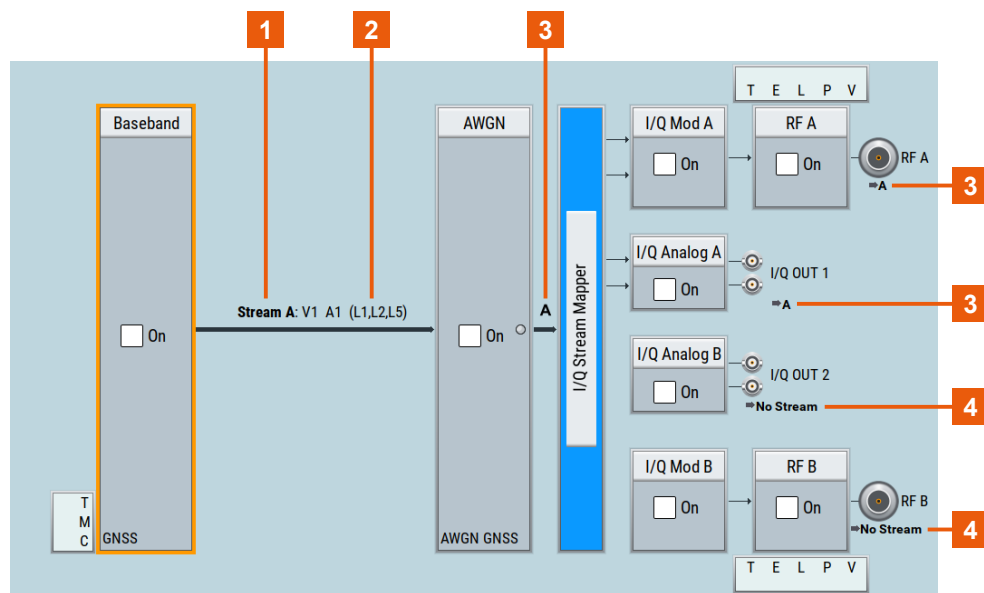

- 1 = GNSS stream from baseband allocation "A"
- 2 = GNSS stream composition: "V1" = vehicle 1, "A1" = antenna 1, "(L1, L2, L5)" = RF bands L1, L2 and L5
- 3 = GNSS stream routing to output connectors "RF A" and analog "I/Q OUT 1"
- 4 = no GNSS stream output connectors

15.1.2 How to set up multifrequency scenarios

The R&S SMW200A offers several configurations to generate multifrequency GNSS signals, depending on the installed options. This section introduces required options and provides procedures for simple dual-frequency and triple-frequency configurations.

For single-frequency configurations, see [Chapter 6, "Satellite constellation"](#), on page 68.

Required options

Equipped as a wideband instrument, the options are required as listed in the table below. These options are required additional to the options in [Table 15-1](#).

Table 15-2: Multifrequency options with R&S SMW-B9

Option	Designation	Remark
R&S SMW-K134	Dual-frequency GNSS	Two options are installable, one per signal path
R&S SMW-K135	Triple-frequency GNSS	Requires R&S SMW-K134. Two options are installable, one per signal path

The configuration offers a flexible generation of multifrequency signals that can be routed to the RF output connectors. Try out the following:

- [To set up a dual-frequency, single-GNSS scenario](#)
- [To set up a triple-frequency, single-GNSS scenario](#)
- [To set up a triple-frequency, multi-GNSS scenario](#)

To set up a dual-frequency, single-GNSS scenario

The procedure assumes a wideband baseband instrument equipped with options R&S SMW-K134 and R&S SMW-K<x>, see [Table 15-1](#).

1. Enable "GNSS Advanced" mode. See ["To enable GNSS advanced mode"](#) on page 269.
2. Select "GNSS" > "GNSS Configuration" > "Systems & Signals".

Systems & Signals					Time	Receiver	Satellites	Atmosphere	Output Streams	Noise / CW Interferer
	System	L1 Band		L2 Band		L5 Band				
GNSS	<input checked="" type="checkbox"/> GPS	C/A		L2C		L5				

Equipped with the GPS options R&S SMW200A-K44 and R&S SMW200A-K98, the default configuration comprises enabled L1 and L2 bands with GPS C/A and L2C signals.

3. Select "GNSS" > "GNSS Configuration" > "Output Streams".

Systems & Signals					Time	Receiver	Satellites	Atmosphere	Output Streams	Noise / CW Interferer
Number of GNSS Streams					1	Lock Output Streams		<input type="checkbox"/>	Monitor ...	
	Vehicle	Antenna	RF Bands	Max. Number of Channels	Active Channels		Output	!!!		
Stream A	V1	A1	L1,L2	612	22 (GPS/22) [6 BB]		RF A			

The configuration comprises one GNSS stream "Stream A" that consists of 22 channels ("Active Channels" = "22") and uses six baseband resources ("[6 BB]"). [Table 15-4](#) summarizes the stream composition and signal routing.

Table 15-3: Triple-frequency GNSS stream for composite GPS signal

GNSS stream	Vehicle	Antenna	RF bands	Channels	Output
"Stream A"	"V1"	"A1"	"L1", "L2"	22 of 612	"RF A"

To reconfigure GNSS stream composition and routing, see [Chapter 15.1.5, "How to configure GNSS streams"](#), on page 278.

- To start composite GNSS signal generation, select "GNSS" > "On" and "RF A" > "On".

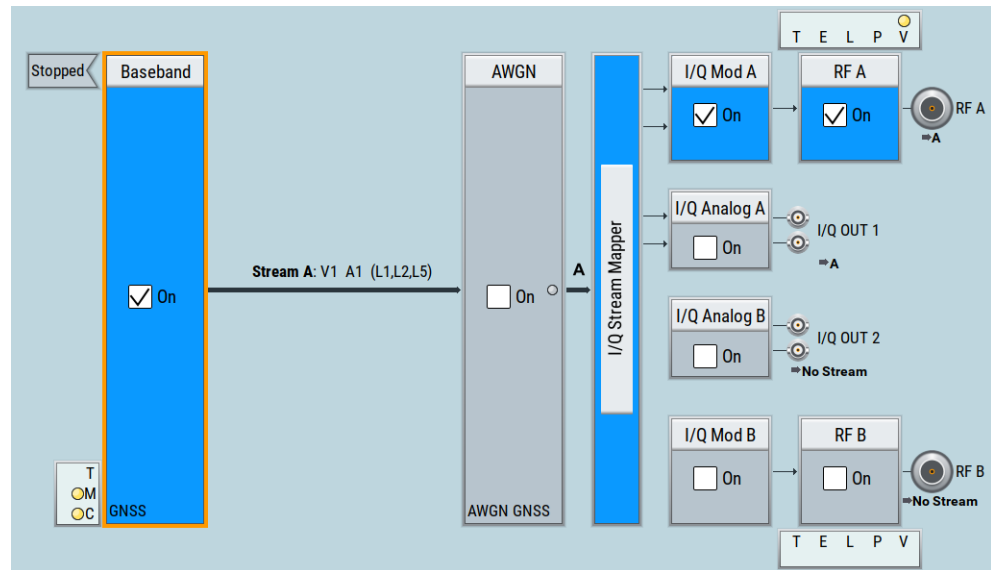

The generated GNSS signal is sufficient for GPS receivers operating in L1, L2 and L5 bands to get a position fix.

To set up a triple-frequency, single-GNSS scenario

The procedure assumes a wideband baseband instrument equipped with options R&S SMW-K134, R&S SMW-K135 and R&S SMW-K<x>, see [Table 15-1](#).

- Enable "GNSS Advanced" mode. See ["To enable GNSS advanced mode"](#) on page 269.
- Select "GNSS" > "GNSS Configuration" > "Systems & Signals".

Systems & Signals		Time	Receiver	Satellites	Atmosphere	Output Streams	Noise / CW Interferer
	System	L1 Band		L2 Band		L5 Band	
GNSS	<input checked="" type="checkbox"/> GPS	C/A		L2C		L5	

Equipped with the GPS options R&S SMW200A-K44 and R&S SMW200A-K98, the default configuration comprises enabled L1, L2 and L5 bands with GPS C/A, L2C and L5 signals.

- To monitor the composition and routing of GNSS streams, select "GNSS" > "GNSS Configuration" > "Output Streams".

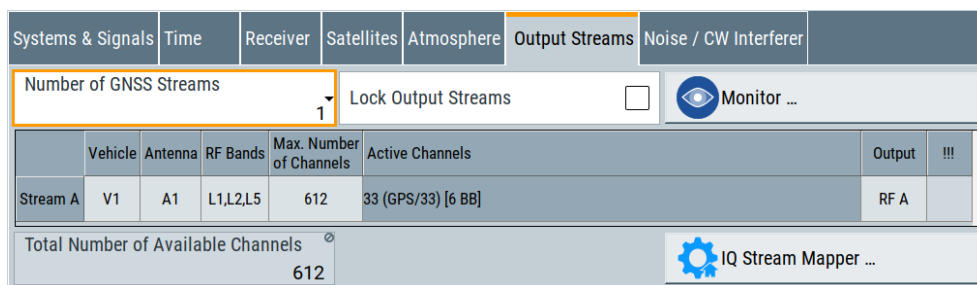

The configuration comprises one GNSS stream "Stream A" that consists of 33 channels ("Active Channels" = "33") and uses six baseband resources ("[6 BB]"). Table 15-4 summarizes the stream composition and signal routing.

Table 15-4: Triple-frequency GNSS stream for composite GPS signal

GNSS stream	Vehicle	Antenna	RF bands	Channels	Output
"Stream A"	"V1"	"A1"	"L1", "L2", "L5"	33 of 612	"RF A"

To reconfigure GNSS stream composition and routing, see Chapter 15.1.5, "How to configure GNSS streams", on page 278.

- To start composite GNSS signal generation, select "GNSS" > "On" and "RF A" > "On".

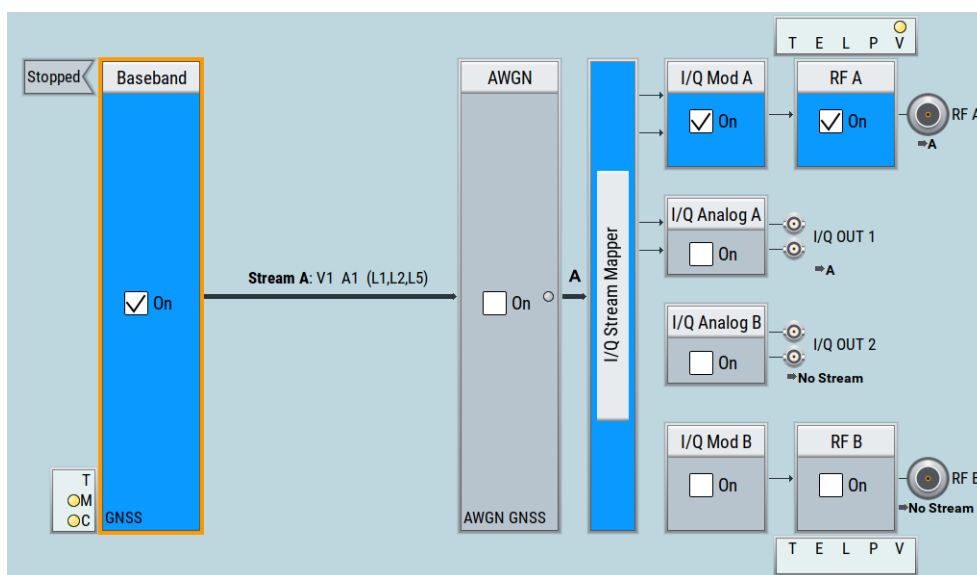

The generated GNSS signal is sufficient for GPS receivers operating in L1, L2 and L5 bands to get a position fix.

To set up a triple-frequency, multi-GNSS scenario

The procedure assumes a wideband baseband instrument equipped with options R&S SMW-K134, R&S SMW-K135 and 4 x R&S SMW-K<x>, see Table 15-1.

- Enable "GNSS Advanced" mode. See "To enable GNSS advanced mode" on page 269.

2. Select "GNSS" > "GNSS Configuration" > "Systems & Signals".
3. Select, for example "System" > "GPS"/"Galileo"/"GLONASS"/"BeiDou" > "On".

Systems & Signals		Time	Receiver	Satellites	Atmosphere	Output Streams	Noise / CW Interferer
GNSS	System	L1 Band	L2 Band		L5 Band		
	<input checked="" type="checkbox"/> GPS	C/A	L2C		L5		
	<input checked="" type="checkbox"/> Galileo	E1 OS	E6		E5a,E5b		
	<input checked="" type="checkbox"/> GLONASS	C/A	C/A				
<input checked="" type="checkbox"/> BeiDou	B1I	B3I		B2I			

Equipped with the basic GNSS options R&S SMW200A-K_x, the configuration comprises enabled L1, L2 and L5 bands with signals as illustrated in the table below.

GNSS	Signals (RF band)
GPS	C/A (L1), L2C (L2), L5 (L5)
Galileo	E1 OS (L1), E6 (L2), E5a (L5), E5b (L5)
GLONASS	C/A (L1), C/A (L2)
BeiDou	B1I (L1), B3I (L2), B2I (L5)

4. To monitor the composition and routing of GNSS streams, select "GNSS" > "GNSS Configuration" > "Output Streams".

Systems & Signals		Time	Receiver	Satellites	Atmosphere	Output Streams	Noise / CW Interferer
Number of GNSS Streams		Lock Output Streams		Monitor ...			
	Vehicle	Antenna	RF Bands	Max. Number of Channels	Active Channels		Output
Stream A	V1	A1	L1,L2,L5	612	119 (GPS/33, Galileo/32, GLONASS/18, BeiDou/36) [6 BB]		RF A

The configuration comprises one GNSS stream "Stream A" that consists of 119 channels ("Active Channels" = "119") and uses six baseband resources ("[6 BB]"). The GNSS systems occupy active channels as follows: GPS = 33, Galileo = 32, GLONASS = 18 and BeiDou = 36.

Table 15-5 summarizes the stream composition and signal routing.

Table 15-5: Triple-frequency GNSS stream for composite multi-GNSS signal

GNSS stream	Vehicle	Antenna	RF bands	Channels	Output
"Stream A"	"V1"	"A1"	"L1", "L2", "L5"	119 of 612	"RF A"

To reconfigure GNSS stream composition and routing, see Chapter 15.1.5, "How to configure GNSS streams", on page 278.

- To start composite GNSS signal generation, select "GNSS" > "On" and "RF A" > "On".

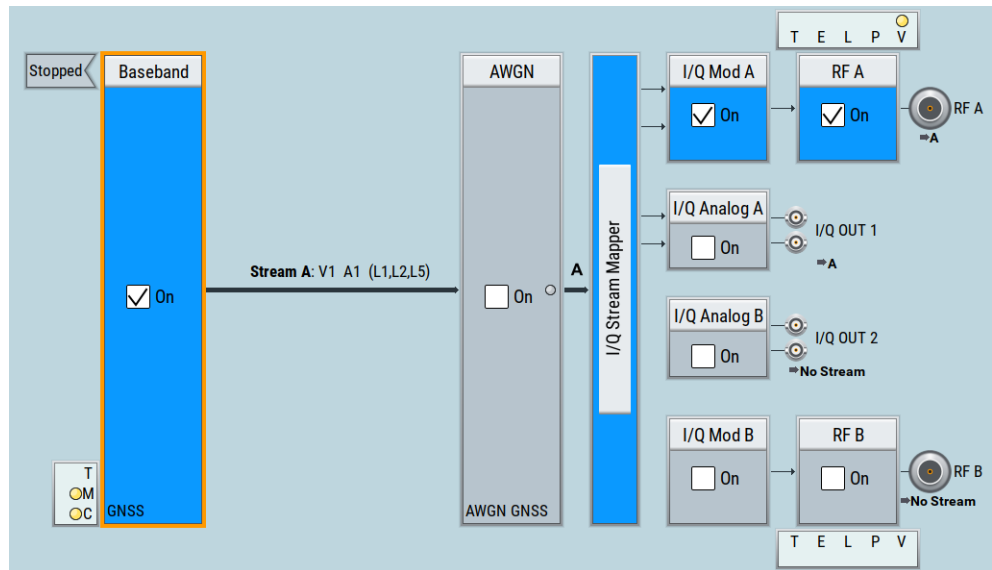

The generated GNSS signal is sufficient for multi-GNSS receivers operating in L1, L2 and L5 bands to get a position fix.

15.1.3 How to set up multi-vehicle scenarios

Required options

See "Required options" on page 268.

To set up a multi-vehicle scenario

The procedure assumes a wideband baseband instrument equipped with options R&S SMW-K134, R&S SMW-K135 and R&S SMW-K<x>, see Table 15-1.

- Enable "GNSS Advanced" mode. See "To enable GNSS advanced mode" on page 269.
- Select "GNSS" > "GNSS Configuration" > "Receiver" > "Number of Vehicles" > "2".
- To monitor the composition and routing of GNSS streams, select "GNSS" > "GNSS Configuration" > "Output Streams".

Systems & Signals	Time	Receiver	Satellites	Atmosphere	Output Streams	Noise / CW Interferer	
Number of GNSS Streams		2	Lock Output Streams		<input type="checkbox"/>	<input type="button" value="Monitor ..."/>	
	Vehicle	Antenna	RF Bands	Max. Number of Channels	Active Channels	Output	!!!
Stream A	V1	A1	L1,L2,L5	306	33 (GPS/33) [3 BB]	RF A	
Stream B	V2	A1	L1,L2,L5	306	33 (GPS/33) [3 BB]	RF B	

The configuration comprises two GNSS streams "Stream A" and "Stream B", one for each vehicle. Each stream consists of 33 channels ("Active Channels" = "33") and uses three baseband resources ("[3 BB]"). The maximum number of channels is equally distributed between the streams.

Table 15-6 summarizes the stream composition and signal routing.

Table 15-6: Double-vehicle GNSS streams

GNSS stream	Vehicle	Antenna	RF bands	Channels	Output
"Stream A"	"V1"	"A1"	"L1", "L2", "L5"	33 of 306	"RF A"
"Stream B"	"V2"	"A1"	"L1", "L2", "L5"	33 of 306	"RF B"

To reconfigure GNSS stream composition and routing, see Chapter 15.1.5, "How to configure GNSS streams", on page 278.

- To start composite GNSS signal generation, select "GNSS" > "On", "RF A" > "On" and "RF B" > "On".

The generated GNSS signal is sufficient for two receivers operating in L1, L2 and L5 bands to get a position fix. Connect one receiver to the "RF A" output and the other receiver to the "RF B" output.

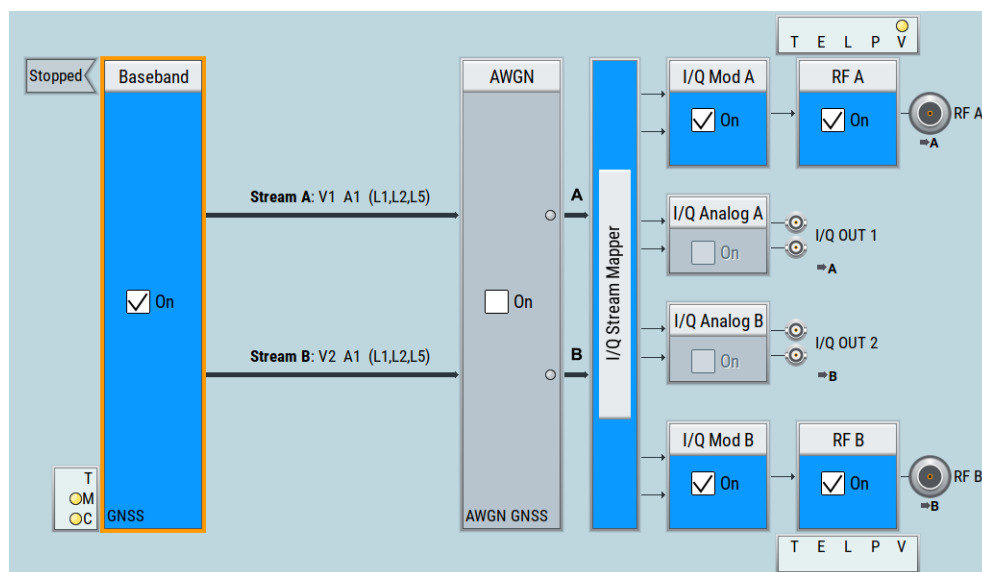

15.1.4 How to set up multi-antenna scenarios

Required options

See "Required options" on page 268.

To set up a multi-antenna scenario

The procedure assumes a wideband baseband instrument equipped with options R&S SMW-K134, R&S SMW-K135 and R&S SMW-K<x>, see [Table 15-1](#).

1. Enable "GNSS Advanced" mode. See ["To enable GNSS advanced mode"](#) on page 269.
2. Select "GNSS" > "GNSS Configuration".
3. Select "Receiver" > "Number of Antennas" > "6".
4. To monitor the composition and routing of GNSS streams, select "GNSS" > "GNSS Configuration" > "Output Streams".

	Vehicle	Antenna	RF Bands	Max. Number of Channels	Active Channels	Output	!!!
Stream A	V1	A1	L1,L2,L5	306	33 (GPS/33) [3 BB]	RF A	
Stream B	V1	A2	L1,L2,L5	306	33 (GPS/33) [3 BB]	RF B	
Stream C	V1	A3	L1,L2,L5	0	0 () [0 BB]	None	⚠
Stream D	V1	A4	L1,L2,L5	0	0 () [0 BB]	None	⚠
Stream E	V1	A5	L1,L2,L5	0	0 () [0 BB]	None	⚠
Stream F	V1	A6	L1,L2,L5	0	0 () [0 BB]	None	⚠

The configuration comprises two GNSS streams "Stream A" to "Stream F", one for each antenna. The first two streams consist of 33 channels ("Active Channels" = "33") each and use three baseband resources ("[3 BB]") each. The maximum number of channels is equally distributed between the two streams. If fully equipped, the maximum number equals 306 channels per stream.

The GNSS streams "Stream C" to "Stream F" contain no signal ("Active Channels" = "0"), since they are not routed to one of the RF output connectors. The conflict is indicated in the "!!!" column with ⚠.

[Table 15-7](#) summarizes the stream composition and signal routing.

Table 15-7: Six antenna GNSS streams

GNSS stream	Vehicle	Antenna	RF bands	Channels	Output
"Stream A"	"V1"	"A1"	"L1", "L2", "L5"	33 of 306	"RF A"
"Stream B"	"V1"	"A2"	"L1", "L2", "L5"	33 of 306	"RF B"
"Stream C" to "Stream F"	"V1"	"A3" to "A6"	"L1", "L2", "L5"	0	"None"

To resolve routing conflicts, see ["To resolve signal routing conflicts"](#) on page 281.

- To start composite GNSS signal generation, select "GNSS" > "On", "RF A" > "On" and "RF B" > "On".

The generated GNSS signal is sufficient for two receivers operating in L1, L2 and L5 bands to get a position fix. Connect one receiver to the "RF A" output and the other receiver to the "RF B" output.

The GNSS streams "Stream C" to "Stream F" are not routed to the output connectors.

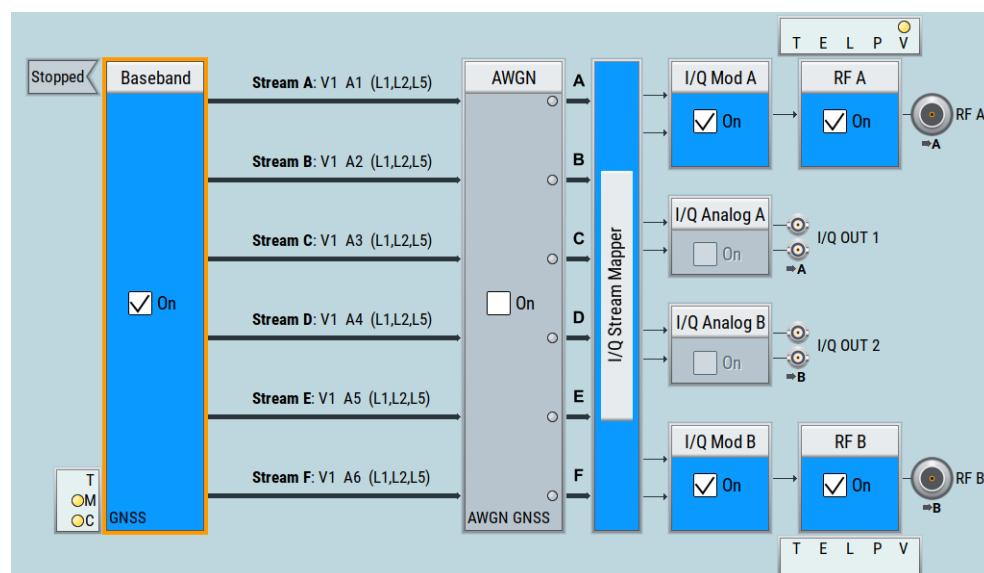

15.1.5 How to configure GNSS streams

This section provides information on how to configure GNSS streams in terms of composition and signal routing.



If you want to change the signal routing of the GNSS streams, use the "Output Streams" dialog. The routing configuration in the "IQ Stream Mapper" dialog is blocked, if GNSS advanced mode is enabled.

The following procedures illustrate the configuration and dependencies of the "Output Streams" dialog:

- [To lock or change the number of GNSS streams](#)
- [To change the composition of GNSS streams](#)
- [To resolve signal routing conflicts](#)

To lock or change the number of GNSS streams

The procedure assumes a R&S SMW200A configured as in ["To set up a triple-frequency, single-GNSS scenario"](#) on page 272. It provides optional steps to lock the output streams or to change the number of streams.

- Select "GNSS" > "GNSS Configuration" > "Output Streams".

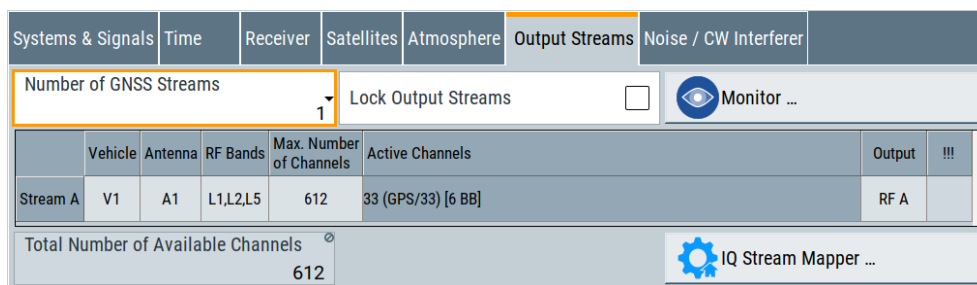

2. Choose between the following:

- Freeze the GNSS stream configuration in terms of number of streams and stream composition including contributing vehicles, antennas and RF bands.

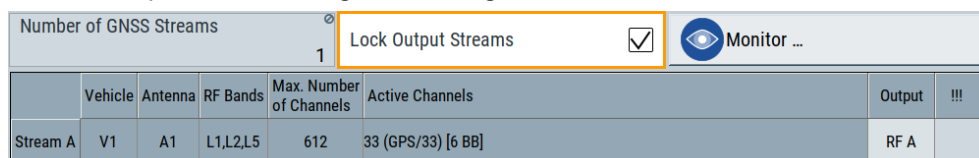

You can still add GNSS systems and signals to "Stream A" to increase the "Active Channels". Adding systems and signals can require installation of "Add x GNSS channels" options, see [Chapter G, "Channel budget"](#), on page 682.

- To change the number of GNSS streams, select for example "Number of GNSS Streams" = "2".

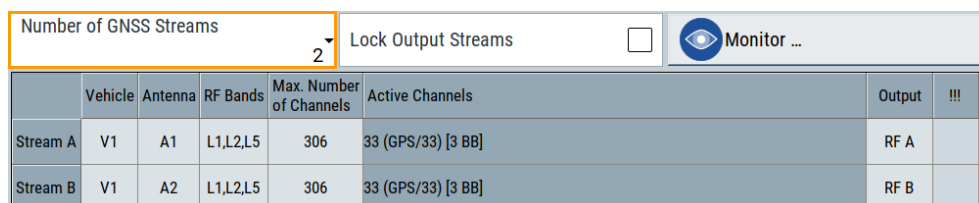

"Stream B" appears in the GNSS stream table with the same composition as "Stream A". "Stream B" is routed to output "RF B".

To change the composition of GNSS streams

The procedure assumes a R&S SMW200A configured as in ["To set up a triple-frequency, single-GNSS scenario"](#) on page 272. It provides optional steps to change the composition of GNSS streams in terms of systems and signal, vehicles, antennas and RF bands.

1. Select "GNSS" > "GNSS Configuration" > "Output Streams".

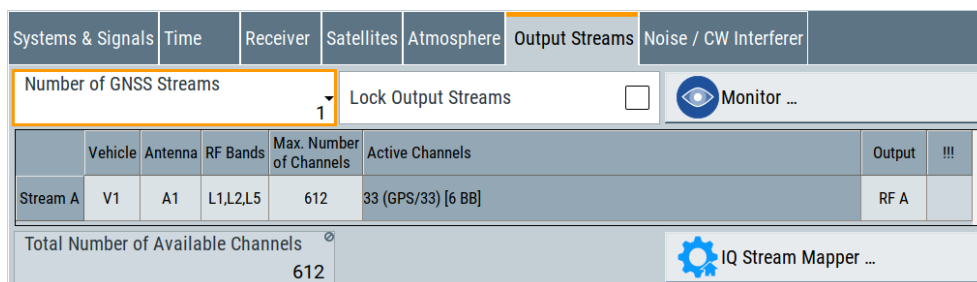

2. Change the simulated vehicle from "V1" to "V2".
 - a) Follow the instructions as in "To set up a multi-vehicle scenario" on page 275.

Systems & Signals	Time	Receiver	Satellites	Atmosphere	Output Streams	Noise / CW Interferer	
Number of GNSS Streams		2		Lock Output Streams		<input type="checkbox"/>	Monitor ...
	Vehicle	Antenna	RF Bands	Max. Number of Channels	Active Channels	Output	!!!
Stream A	V1	A1	L1,L2,L5	306	33 (GPS/33) [3 BB]	RF A	
Stream B	V2	A1	L1,L2,L5	306	33 (GPS/33) [3 BB]	RF B	

- b) In the row of "Stream A", select "Vehicle" > "V2".
- c) To increase channel capacity within the stream you want to use, for example for "Stream A":
 In "Stream B", set "Max. Number of Channels" = "0" and in "Stream A", set the maximum value, for example 612, if fully equipped.

	Vehicle	Antenna	RF Bands	Max. Number of Channels	Active Channels	Output	!!!
Stream A	V2	A1	L1,L2,L5	612	33 (GPS/33) [6 BB]	RF A	
Stream B	V1	A1	L1,L2,L5	0	0 () [0 BB]	RF B	

"Stream B" carries no signal or channels, a warning is displayed in column "!!!".

3. Change the simulated antenna, e.g. from "A1" to "A2".
 - a) Select "Receiver" > "Number of Antennas" > "2".
 A new stream "Stream B", containing signals for the antenna "A2" is added to the stream table. You can use "Stream B", since it already contains the contribution of the antenna "A2".
 - b) In the row of "Stream B", select "Output" > "RF A".
 - c) To increase channel capacity within "Stream B":
 In "Stream A", set "Max. Number of Channels" = "0" and in "Stream B", set the maximum value, for example 612, if fully equipped.

	Vehicle	Antenna	RF Bands	Max. Number of Channels	Active Channels	Output	!!!
Stream A	V1	A1	L1,L2,L5	0	0 () [0 BB]	RF A	
Stream B	V1	A2	L1,L2,L5	612	33 (GPS/33) [6 BB]	RF A	
Stream C	V2	A1	L1,L2,L5	0	0 () [0 BB]	None	

"Stream A" carries no signal or channels, a warning is displayed in column "!!!".

4. Change the RF bands contributing to the stream.
 - a) In the "RF Bands" column of the "Stream B" row, deselect, e.g. "L5".
 The number of "Active Channels" reduces to 22.

	Vehicle	Antenna	RF Bands	Max. Number of Channels	Active Channels	Output	!!!
Stream A	V1	A1	L1,L2	0	0 () [0 BB]	RF A	
Stream B	V1	A2	L1,L2	612	22 (GPS/22) [6 BB]	RF A	
Stream C	V2	A1	L1,L2,L5	0	0 () [0 BB]	None	

To resolve signal routing conflicts

The procedure assumes a R&S SMW200A configured as in "To set up a multi-antenna scenario" on page 277. It provides steps to resolve routing conflicts due to limited routing to two RF outputs.

1. Select "GNSS" > "GNSS Configuration" > "Output Streams".

	Vehicle	Antenna	RF Bands	Max. Number of Channels	Active Channels	Output	!!!
Stream A	V1	A1	L1,L2,L5	306	33 (GPS/33) [3 BB]	RF A	
Stream B	V1	A2	L1,L2,L5	306	33 (GPS/33) [3 BB]	RF B	
Stream C	V1	A3	L1,L2,L5	0	0 () [0 BB]	None	
Stream D	V1	A4	L1,L2,L5	0	0 () [0 BB]	None	
Stream E	V1	A5	L1,L2,L5	0	0 () [0 BB]	None	
Stream F	V1	A6	L1,L2,L5	0	0 () [0 BB]	None	

Total Number of Available Channels: 612

There are routing conflicts for "Stream C" to "Stream F", since you cannot route them to output connectors, other than "RF A" and "RF B".

2. Assign RF output connectors for "Stream C" to "Stream F":
 - a) Select for example "Output" > "RF A" for streams "A" to "C".
 - b) Select for example "Output" > "RF B" for streams "D" to "F".

All signal routing conflicts are resolved. The total number of available channels is equally distributed onto the six streams. Each stream consists of 33 active channels and simulates one individual antenna.

	Vehicle	Antenna	RF Bands	Max. Number of Channels	Active Channels	Output	!!!
Stream A	V1	A1	L1,L2,L5	102	33 (GPS/33) [1 BB]	RF A	
Stream B	V1	A2	L1,L2,L5	102	33 (GPS/33) [1 BB]	RF A	
Stream C	V1	A3	L1,L2,L5	102	33 (GPS/33) [1 BB]	RF A	
Stream D	V1	A4	L1,L2,L5	102	33 (GPS/33) [1 BB]	RF B	
Stream E	V1	A5	L1,L2,L5	102	33 (GPS/33) [1 BB]	RF B	
Stream F	V1	A6	L1,L2,L5	102	33 (GPS/33) [1 BB]	RF B	

You can monitor signal routing of the GNSS streams in the block diagram.

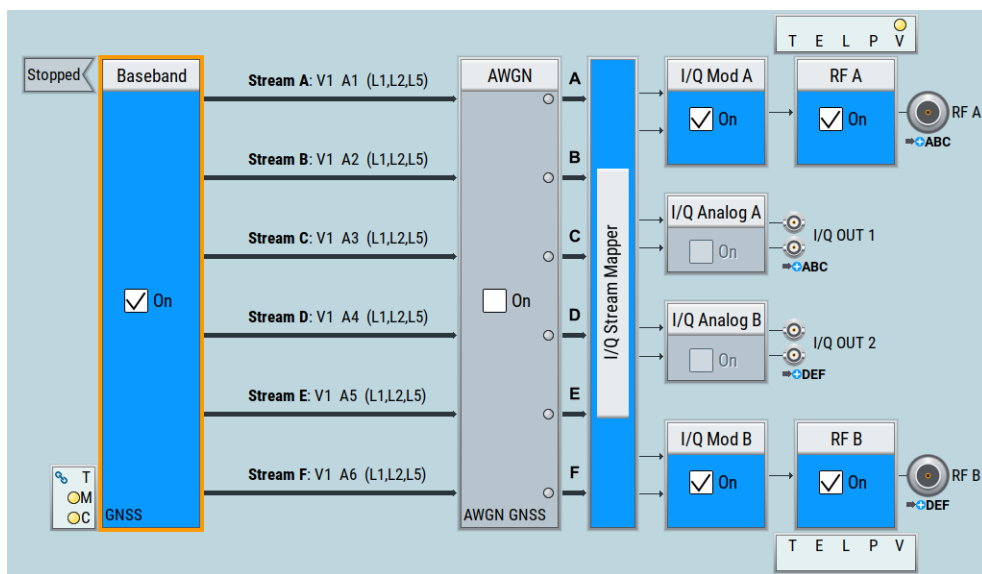

Signal routing to the output connectors via the "IQ Stream Mapper" and applying frequency offsets and power offsets is not part of this description.

For details, see R&S SMW200A User Manual.

15.2 Advanced GNSS settings

This section provides settings related to GNSS advanced mode and output streams settings.

15.2.1 Related settings

This section lists only on the settings that are dedicated to advanced mode. The settings require enabled advanced mode, see [Chapter 15.1, "How to set up advanced GNSS scenarios"](#), on page 268.

Number of Vehicles..... 283
 Simulation Monitor settings..... 283
 L Vehicle..... 283
 L Antenna..... 283
 L Stream..... 284
 Channels..... 284
 Reference Vehicle..... 285

Number of Vehicles

Access: Select "GNSS" > "GNSS Configuration" > "Receiver".

Sets the number of simulated vehicles.

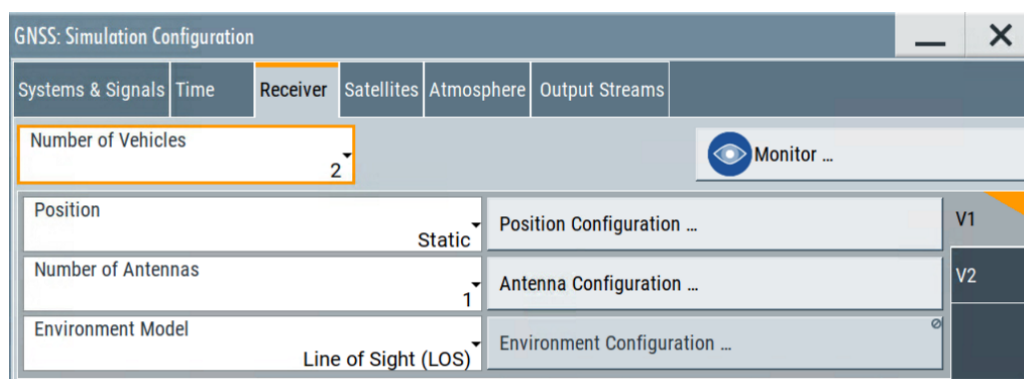

Further receiver settings, like position, antennas or environment effects apply for the vehicle indicated on the side tab.

Remote command:

`[:SOURCE<hw>] :BB:GNSS:VEHICLE:COUNT` on page 639

Simulation Monitor settings

Access: Select "GNSS" > "Simulation Monitor".

Specify vehicle and antenna to monitor parameters, which they relate to.

Vehicle ← Simulation Monitor settings

Access: Select "Display" > "Power View".

Selects the vehicle for that the displayed information applies.

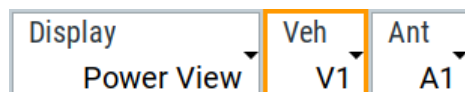

"V2" is selectable, if "Number of Vehicles" = "2".

Remote command:

`[:SOURCE<hw>] :BB:GNSS:MONITOR<ch>:DISPLAY:VEHICLE` on page 607

Antenna ← Simulation Monitor settings

Access: Select "Display" > "Power View".

Selects the antenna for that the displayed information applies.

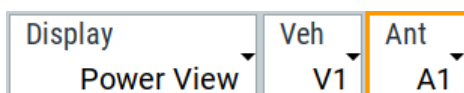

The selection depends on the number of antennas set via "Receiver" > "Number of Antennas".

Remote command:

`[:SOURce<hw>] :BB:GNSS:MONitor<ch>:DISPlay:ANTenna` on page 608

Stream ← Simulation Monitor settings

Access: Select "Display" > "HW Channels".

Switches between available GNSS streams. You can switch between up to six streams.

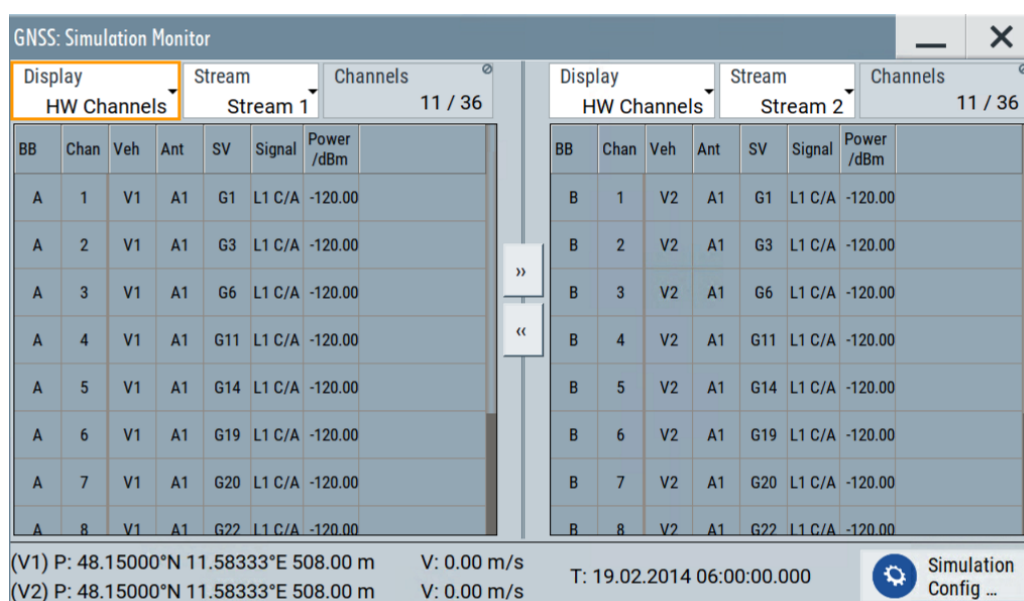

Figure 15-1: HW channels view for GNSS Stream 1 and GNSS Stream 2

Remote command:

`[:SOURce<hw>] :BB:GNSS:MONitor<ch>:DISPlay:STReam` on page 611

Channels

Requires "Display" > "HW Channels".

Displays the number of active GNSS channels ("x") and allocated GNSS channels ("y"). The number of active channels is automatically configured depending on the number of active GNSS systems, signals, satellites, vehicles and antennas. The number of allocated channels is also the maximum number of channels.

A GNSS channel refers to a hardware unit that is required to process and generate a GNSS signal. GNSS channels are uniquely composed of the following configuration elements: One vehicle/receiver, one antenna, one RF band and one signal of a single satellite.

R&S SMW-B9: In GNSS Advanced baseband mode "Channels x/y" are indicated for the selected GNSS stream, see "Stream" on page 284.

The maximum number of channels depends on the installed options. See [Chapter G, "Channel budget"](#), on page 682.

Remote command:

```
[ :SOURCE<hw> ] :BB:GNSS:MONitor<ch>:DISPlay:CHANnels:USED?
```

on page 612

```
[ :SOURCE<hw> ] :BB:GNSS:MONitor<ch>:DISPlay:CHANnels:ALlocated?
```

on page 611

To set the maximum number of channels of a GNSS stream requires R&S SMW-B9.

```
[ :SOURCE<hw> ] :BB:GNSS:STReam<st>:CHANnels:MAX on page 637
```

Reference Vehicle

Access: "GNSS" > "GNSS Configuration" > "Satellites" > "SV Selection Configuration".

Defines the vehicle, for that the displayed satellite constellation in the "Satellites" dialog applies.

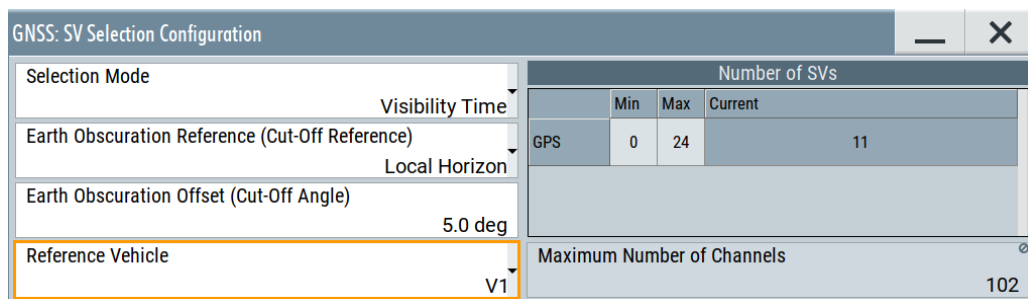

"V2" is selectable, if you set two vehicles in the GNSS receiver settings, see ["Number of Vehicles"](#) on page 283.

Remote command:

```
[ :SOURCE<hw> ] :BB:GNSS:SV:SElection:REference:VEHICLE on page 639
```

15.2.2 Output streams settings

Access:



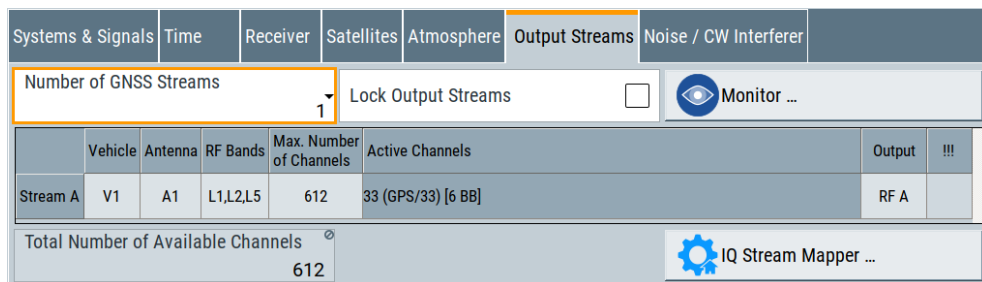

1. Enable "GNSS Advanced" mode.
See [Chapter 15.1.1, "How to enable GNSS advanced mode"](#), on page 268.
2. Select "GNSS" > "GNSS Configuration" > "Output Streams".



The tab provides settings to configure the number and composition of the GNSS streams. It further displays information on active and total number of GNSS channels and indicates setting conflicts.

Output stream-mapping table

The mapping table allows for flexible configuration of composition and signal routing of GNSS streams. A routing conflict is indicated by , e.g. if a GNSS stream is not routed to one of the RF output connectors.

	Vehicle	Antenna	RF Bands	Max. Number of Channels	Active Channels	Output	!!!
Stream A	V1	A1	L1,L2,L5	306	33 (GPS/33) [3 BB]	RF A	
Stream B	V1	A2	L1,L2,L5	306	33 (GPS/33) [3 BB]	RF B	
Stream C	V1	A3	L1,L2,L5	0	0 () [0 BB]	None	
Stream D	V1	A4	L1,L2,L5	0	0 () [0 BB]	None	
Stream E	V1	A5	L1,L2,L5	0	0 () [0 BB]	None	
Stream F	V1	A6	L1,L2,L5	0	0 () [0 BB]	None	

How to: [Chapter 15.1, "How to set up advanced GNSS scenarios"](#), on page 268.

Settings

Number of GNSS Streams.....	286
Lock Output Streams.....	286
Output Stream-Mapping table.....	287
L Vehicle.....	287
L Antenna.....	287
L RF Bands.....	287
L Max. Number of Channels.....	287
L Active Channels.....	287
L Output.....	288
L Conflict.....	288
Maximum Number of Channels/Total Number of Available Channels.....	288
Baseband Offsets.....	288
IQ Stream Mapper.....	288

Number of GNSS Streams

Sets the maximum number of GNSS streams.

See also "GNSS stream" on page 267.

Remote command:

[:SOURce<hw>] :BB:GNSS:OSTReams:COUNT on page 635

Lock Output Streams

Freezes the configuration in the output stream-mapping table.

Affected parameters are "Number of GNSS Streams", "Vehicle", "Antenna", "RF Bands" and "Max. Number of Channels". Configuration of the output stream to the output connectors "RF A" or "RF B" is still possible.

How to: ["To lock or change the number of GNSS streams"](#) on page 278

Remote command:

`[:SOURCE<hw>] :BB:GNSS:OSTREAMS:LOCK` on page 635

Output Stream-Mapping table

Provides settings to configure composition and signal routing of GNSS streams in a table.

Vehicle ← Output Stream-Mapping table

Selects the signal of which vehicle is carried by which GNSS stream. Selection requires "Number of Vehicles" = "2".

How to: [Chapter 15.1.3, "How to set up multi-vehicle scenarios"](#), on page 275

Remote command:

`[:SOURCE<hw>] :BB:GNSS:STREAM<st>:VEHICLE` on page 638

Antenna ← Output Stream-Mapping table

Selects the signal of which antenna is carried by which GNSS stream.

How to: [Chapter 15.1.4, "How to set up multi-antenna scenarios"](#), on page 276

Remote command:

`[:SOURCE<hw>] :BB:GNSS:STREAM<st>:ANTENNA` on page 636

RF Bands ← Output Stream-Mapping table

Selects the RF bands contributing to the GNSS stream.

Remote command:

`[:SOURCE<hw>] :BB:GNSS:STREAM<st>:RFBAND` on page 638

Max. Number of Channels ← Output Stream-Mapping table

"Max. Number of Channels" requires R&S SMW-B9.

Sets the maximum number of channels per stream. It depends on the "Total Number of Available Channels", see ["Maximum Number of Channels/Total Number of Available Channels"](#) on page 81.

Remote command:

`[:SOURCE<hw>] :BB:GNSS:STREAM<st>:CHANNELS:MAX` on page 637

`[:SOURCE<hw>] :BB:GNSS:STREAM<st>:BB:COUNT` on page 636

Active Channels ← Output Stream-Mapping table

Requires R&S SMW-B9.

Displays the number of active channels per stream and per GNSS system. Also, displays the number of allocated baseband sources.

Active Channels

130 (GPS/44, Galileo/32, GLONASS/18, BeiDou/36) [6 BB]

The parameter is not affected by "Lock Output Streams". You can still add systems and signals to the GNSS stream via the "Systems & Signals" dialog.

Remote command:

`[:SOURCE<hw>] :BB:GNSS:STReam<st>:BB:INFO?` on page 636

Output ← Output Stream-Mapping table

Requires R&S SMW-B9.

Sets the output connector to that the output GNSS signal is routed.

Remote command:

`[:SOURCE<hw>] :BB:GNSS:STReam<st>:OUTPut` on page 638

Conflict ← Output Stream-Mapping table

Indicates routing or setting conflicts when routing the GNSS stream to the output connector.

Remote command:

Stream-specific conflicts

`[:SOURCE<hw>] :BB:GNSS:STReam<st>:CONFLICT?` on page 635

Output stream configuration conflicts

`[:SOURCE<hw>] :BB:GNSS:OSTReams:CONFLICT?` on page 635

Maximum Number of Channels/Total Number of Available Channels

Requires R&S SMW-B9.

Displays the maximum or total number of channels. Editing the parameter requires "Mode" > "GNSS Advanced".

You can simulate up to 612 GNSS channels. The number depends on the simulation capacity, see [Chapter G, "Channel budget"](#), on page 682.

Remote command:

`[:SOURCE<hw>] :BB:GNSS:SV:SELECTION:CHANnels:MAX` on page 442

Baseband Offsets

Requires R&S SMW-B10.

Accesses the "Baseband Offsets" dialog where you can apply a frequency or power offset on the baseband signals relative to the signals of the other baseband sources.

For details, see R&S SMW200A User Manual.

IQ Stream Mapper

Accesses the "IQ Stream Mapper" dialog where you can change the routing of the signal streams to the available output connectors.

For details, see R&S SMW200A User Manual.

16 Data logging

Data logging is a feature that enables you to acquire and download navigation data. You can log real-time data and offline data. Save logged data in files on the hard disk, in any network directory or on a remote computer.

Data logging not available for hardware in the loop (HIL) receiver testing. If you activate logging in HIL mode, a warning message indicates a settings conflict. See also ["State"](#) on page 292 and ["Position"](#) on page 53.

Application

Download and offline postprocessing of navigation data can be a useful source for basic analysis, for example for validation of the received parameters, for monitoring or documentation tasks. For example, you can log the simulated longitude, latitude and altitude parameters or the ionospheric errors and compare these values with the values at the receiver.

Filename syntax

The generated files are saved in the selected [Directory](#) and their filenames follow the syntax `log_<Mode>_<Logging_Category/>`

Format `<[<YYMMDD>_<HHMMSS>]>_<Stream#>_<V#>_<A#>_<L#>`, where:

- `<Mode>` corresponds to the selected ["Mode"](#) on page 292
- `<Logging_Category/Format>` corresponds to the enabled category/format in the [Logging formats and categories](#) table.
The available categories/formats are: `Satellite`, `UserMotion`.
- `<YYMMDD>_<HHMMSS>` is the system time, appended if [Create New Subdirectory for Each Run](#) > "On".
- `<Stream#>_<V#>_<A#>_<L#>` indicate the logged stream, vehicle and antenna number, and the RF band.

File format of the generated files

Logged navigation data is saved as `*.csv` files. The coma-separated file format is self-explanatory.

File content

Two kinds of parameters define the content of the logging files: parameters that set what is logged and parameter that set how long and how often it is logged.

The logged data per file format and logging category is defined in the dialogs:

- ["Logged Satellite Parameters"](#) on page 295
- ["Logged User Motion Parameters"](#) on page 297

The time span, the number of logged records and the timestamp of the first logging recorded are:

- **Time span**

If logging is performed offline, the parameter "Duration" defines the time span that is logged.

In real time mode, the time span is the time that elapses between the moment you start and stop the logging (select "On" and "Off").

- **Number of logged records**

The number of logged records is defined by the logged time span and by the logging resolution ("Log Step").

- **First logged record**

In real time mode, the timestamp of the first logged record is the time indicated with the parameter "Simulation Start Time".

In offline mode, it is defined as "Simulation Start Time" + "Time Offset" + "Log Step".

Example:

- "GNSS Configuration" > "System & Signals" > "GPS C/A" > "On", "L1" > "On"
- "Satellites" > "SV Selection Configuration" > "Number of SVs" > "Max" = "4"
- "Time" > "Simulation Start" > "UTC", "Date" = "2014-02-19", "Time" = "06:00:00.000".
- "Data Logging" > "Mode" > "Offline", "Data Logging" > "Time Offset" = "0 ms", "Duration" = "60.000 s", "Logging Category" > "Satellite" > "On", "Log Step (s)" = "10".
- "Data Logging" > "Generate"

Created is the file `log_offline_Satellite.csv` with file content as shown on [Figure 16-1](#).

The file content has been formatted for better reading; line numbers are included for description purposes.

Elapsed Time [s]	UTC Date [dd/mm/yyyy]	UTC Time [hh:mm:ss.ms]	Standard	ID	Elevation [deg]	Azimuth [deg]
10.0	19.02.2014	06:00:10.000	G	14	166.314	-652.828
10.0	19.02.2014	06:00:10.000	G	15	441.335	861.655
20.0	19.02.2014	06:00:10.000	G	18	691.797	-962.890
10.0	19.02.2014	06:00:10.000	G	25	200.406	-1.740.554
20.0	19.02.2014	06:00:20.000	G	14	166.815	-652.321
20.0	19.02.2014	06:00:20.000	G	15	440.842	862.494
20.0	19.02.2014	06:00:20.000	G	18	691.877	-965.182
20.0	19.02.2014	06:00:20.000	G	25	201.147	-1.740.627
30.0	19.02.2014	06:00:30.000	G	14	167.317	-651.815
30.0	19.02.2014	06:00:30.000	G	15	440.349	863.332
30.0	19.02.2014	06:00:30.000	G	18	691.954	-967.476
30.0	19.02.2014	06:00:30.000	G	25	201.889	-1.740.700
40.0	19.02.2014	06:00:40.000	G	14	167.818	-651.310
40.0	19.02.2014	06:00:40.000	G	15	439.856	864.168
40.0	19.02.2014	06:00:40.000	G	18	692.027	-969.772
40.0	19.02.2014	06:00:40.000	G	25	202.631	-1.740.772
50.0	19.02.2014	06:00:50.000	G	14	168.320	-650.805
50.0	19.02.2014	06:00:50.000	G	15	439.362	865.004
50.0	19.02.2014	06:00:50.000	G	18	692.096	-972.071
50.0	19.02.2014	06:00:50.000	G	25	203.373	-1.740.844

Figure 16-1: Data logging: Example of a logged data (file extract)

1 = Logging time; first record made at "Time Offset + Log Step"

2 = Logged are 4 GPS satellites (SV IDs = 14, 15, 18, 25)

3 = Logged parameters (not all possible are enabled)

Rows 4, 5 = Difference in time between the rows 4 and 5, 8 and 9 etc. is the "Log Step"

Row 20 = The last record is 50 s after the logging start ("Log Step = 10s" and the next record is 60 s after logging start that is the end of the logging duration)

16.1 Data logging general settings

Access:

- ▶ Select "Data Generation" > "Data Logging".

The tab provides settings that depend on the selected **Mode**. The differences are self-explanatory.

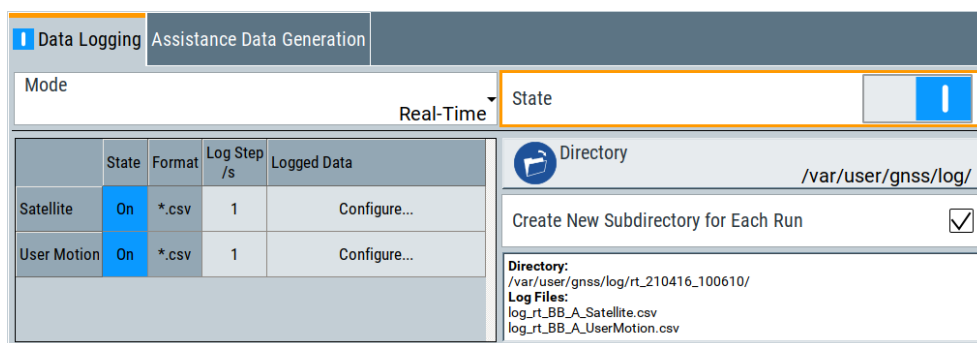

The remote commands required to define these settings are described in [Chapter 22.19, "Data logging commands"](#), on page 624.

Settings:

Mode..... 292

State..... 292

Generate..... 293

Time Offset..... 293

Duration..... 293

Directory..... 293

Create New Subdirectory for Each Run..... 293

Logging formats and categories..... 294

 L State..... 294

 L Format..... 294

 L Log Step /s..... 294

 L Configure Logging..... 294

Mode

Sets the logging mode.

You can log real-time data and offline navigation data.

"Real-Time" Logs real-time navigation data during runtime of the GNSS simulation.

"Offline" Logs offline navigation data for a specified duration of the GNSS simulation.

Remote command:

`[:SOURCE<hw>] :BB:GNSS:LOGGING:MODE` on page 626

State

Enables data logging.

Note: Existing files with the same name are overwritten. If you save the logged data to files, first check if the selected folder is empty. The folder is specified via the [Directory](#) configuration.

To prevent overwriting, activate [Create New Subdirectory for Each Run](#).

"On" Logging is initialized and logging starts.

"Off" Logging files are saved.

Remote command:

`[:SOURce<hw>] :BB:GNSS:LOGGing:RT:STATe` on page 626

Generate

Creates and saves logging files.

Note: Existing files with the same name are overwritten. If you save the logged data to files, first check if the selected folder is empty. The folder is specified via the [Directory](#) configuration.

To prevent overwriting, activate [Create New Subdirectory for Each Run](#).

Remote command:

`[:SOURce<hw>] :BB:GNSS:LOGGing:OFFLine:GENerate` on page 626

`[:SOURce<hw>] :BB:GNSS:LOGGing:OFFLine:ABORt` on page 626

Time Offset

Requires "Mode" > "Offline".

Delays the logging start. The first logged point of time is as follows:

"Simulation Start Time" + "Time Offset" + "Log Step".

Remote command:

`[:SOURce<hw>] :BB:GNSS:LOGGing:OFFLine:TOFFset` on page 626

Duration

Requires "Mode" > "Offline".

Sets the time span that is logged.

Remote command:

`[:SOURce<hw>] :BB:GNSS:LOGGing:OFFLine:DURation` on page 627

Directory

Opens the standard "File Select" dialog and defines the storage place.

See also ["Filename syntax"](#) on page 289.

Remote command:

`[:SOURce<hw>] :BB:GNSS:LOGGing:DESTination:FILE:DIRectory`
on page 627

Create New Subdirectory for Each Run

Adds a time stamp to the logging files.

Creates subdirectories with time stamp and saves the logged files in them. Enable this parameter to prevent that files are overwritten.

If logging is enabled, the filenames of the created files and the folder structure are indicated.

See also ["Filename syntax"](#) on page 289.

Remote command:

`[:SOURce<hw>] :BB:GNSS:LOGGing:DESTination:FILE:DIRectory`
on page 627

`[:SOURce<hw>] :BB:GNSS:LOGGing:DESTination:FILE:TAPPend[:STATe]`
on page 627

Logging formats and categories

The logging categories and logging formats are listed in table form.

Each logging category is defined with:

State ← Logging formats and categories

Enables logging of this particular category.

Remote command:

[\[:SOURCE<hw>\]:BB:GNSS:LOGGING:CATEGORY:SATELLITE:STATE](#) on page 628

[\[:SOURCE<hw>\]:BB:GNSS:LOGGING:CATEGORY:UMOTION:STATE](#) on page 628

Format ← Logging formats and categories

Sets the file format in that the logged data is saved.

Remote command:

[\[:SOURCE<hw>\]:BB:GNSS:LOGGING:CATEGORY:UMOTION:FORMAT?](#) on page 628

Log Step /s ← Logging formats and categories

Sets the logging step, i.e. the resolution of the logged data per format and category.

Example:

A file generated in "Mode" > "Offline" with "Duration" = "60 s" and "Log Step (s)" = "10 " has six records per SV ID.

The first one is made 10s after the "Simulation Start Time" + "Time Offset" and the next steps are made after 10s each.

Observe also the file content of the log file. The first logging parameter `Elapsed_Time_ms` indicates the log steps.

Remote command:

[\[:SOURCE<hw>\]:BB:GNSS:LOGGING:CATEGORY:SATELLITE:STEP](#) on page 628

[\[:SOURCE<hw>\]:BB:GNSS:LOGGING:CATEGORY:UMOTION:STEP](#) on page 628

Configure Logging ← Logging formats and categories

Opens the "Logging Satellites/User Motion" dialog to configure the messages to be logged, see [Chapter 16.2, "Configure logging settings"](#), on page 294.

16.2 Configure logging settings

Access:

1. Select "Data Generation" > "Data Logging".
2. In the logging formats and category table, select "Satellite" > "Logged Data" > "Configure".

GNSS: Logging Satellites (csv)	
Select All	Deselect All
Elevation / deg <input checked="" type="checkbox"/>	Pseudorange Bias / m <input checked="" type="checkbox"/>
Azimuth / deg <input checked="" type="checkbox"/>	Pseudorange Bias Rate / m/s <input checked="" type="checkbox"/>
Position (ECEF) / m <input checked="" type="checkbox"/>	Range / m <input checked="" type="checkbox"/>
Velocity (ECEF) / m/s <input checked="" type="checkbox"/>	Range Rate / m/s <input checked="" type="checkbox"/>
Acceleration (ECEF) / m/s ² <input checked="" type="checkbox"/>	Doppler Shift / Hz <input checked="" type="checkbox"/>
Clock Bias / m <input checked="" type="checkbox"/>	Carrier Phase / deg <input checked="" type="checkbox"/>
Signal Level / dBm <input checked="" type="checkbox"/>	Tropospheric Delay / m <input checked="" type="checkbox"/>
Pseudorange / m <input checked="" type="checkbox"/>	Ionospheric Delay / m <input checked="" type="checkbox"/>
Pseudorange Rate / m/s <input checked="" type="checkbox"/>	

3. Select "User Motion" > "Logged Data" > "Configure".

GNSS: Logging User Motion (csv)	
Select All	Deselect All
Position (LLA) / deg,deg,m <input checked="" type="checkbox"/>	Attitude (YPR) <input checked="" type="checkbox"/>
Position (ENU) / m,m,m <input checked="" type="checkbox"/>	Attitude Rate (YPR) <input checked="" type="checkbox"/>
Position (ECEF) / m <input checked="" type="checkbox"/>	Attitude Acceleration (YPR) <input checked="" type="checkbox"/>
Velocity (ECEF) / m/s <input checked="" type="checkbox"/>	Attitude Jerk (YPR) <input checked="" type="checkbox"/>
Acceleration (ECEF) / m/s ² <input checked="" type="checkbox"/>	Number of Visible SVs <input checked="" type="checkbox"/>
Jerk (ECEF) / m/s ³ <input checked="" type="checkbox"/>	GDOP <input checked="" type="checkbox"/>
Velocity (Local NED) / m/s <input checked="" type="checkbox"/>	PDOP <input checked="" type="checkbox"/>
Ground Speed / m/s <input checked="" type="checkbox"/>	HDOP <input checked="" type="checkbox"/>
Antenna Offset (ECEF) / m <input checked="" type="checkbox"/>	VDOP <input checked="" type="checkbox"/>
	TDOP <input checked="" type="checkbox"/>

Settings:

[Logged Satellite Parameters](#)..... 295
[Logged User Motion Parameters](#)..... 297

Logged Satellite Parameters

Selects the information to be logged.

Use the "Select All"/"Deselect All" function to select all or none of the parameters.

Configure logging settings

Parameter	Description	Remote command
Elevation (deg) Azimuth (deg)	Elevation and azimuth arrival angles of the satellites signal	<code>[:SOURCE<hw>] :BB:GNSS:LOGGING:CATegory: SATellite:ELEVation</code> on page 629 <code>[:SOURCE<hw>] :BB:GNSS:LOGGING:CATegory: SATellite:AZIMuth</code> on page 629
Position (ECEF) (m) Velocity (ECEF) (m/s) Acceleration (ECEF) (m/s ²)	Satellites position, velocity and acceleration	<code>[:SOURCE<hw>] :BB:GNSS:LOGGING:CATegory: SATellite:POSition:ECEF</code> on page 629 <code>[:SOURCE<hw>] :BB:GNSS:LOGGING:CATegory: SATellite:VELocity:ECEF</code> on page 629 <code>[:SOURCE<hw>] :BB:GNSS:LOGGING:CATegory: SATellite:ACCeleration:ECEF</code> on page 629
Clock Bias (m)	Change in the satellite's range in the satellite clock over a time interval	<code>[:SOURCE<hw>] :BB:GNSS:LOGGING:CATegory: SATellite:CBias</code> on page 629
Signal Level (dBm)	Power of the LOS (Line of sight) signal; Multipath effects or attenuation because of used antenna patterns are not considered	<code>[:SOURCE<hw>] :BB:GNSS:LOGGING:CATegory: SATellite:SLEvel</code> on page 629
Pseudorange (m)	Simulated signal delay	<code>[:SOURCE<hw>] :BB:GNSS:LOGGING:CATegory: SATellite:PRANge</code> on page 629
Pseudorange Rate (m/s)	Rate of change of simulated signal delay	<code>[:SOURCE<hw>] :BB:GNSS:LOGGING:CATegory: SATellite:PRRate</code> on page 629
Pseudorange Bias (m)		<code>[:SOURCE<hw>] :BB:GNSS:LOGGING:CATegory: SATellite:PRBias</code> on page 629
Pseudorange Bias Rate (m/s)		<code>[:SOURCE<hw>] :BB:GNSS:LOGGING:CATegory: SATellite:PRBRate</code> on page 629
Range (m)	Satellite range	<code>[:SOURCE<hw>] :BB:GNSS:LOGGING:CATegory: SATellite:RANge</code> on page 629
Range Rate (m/s)	Rate of change of range	<code>[:SOURCE<hw>] :BB:GNSS:LOGGING:CATegory: SATellite:RRATE</code> on page 629
Doppler Shift (Hz)	Pseudorange rate converted to frequency	<code>[:SOURCE<hw>] :BB:GNSS:LOGGING:CATegory: SATellite:DSHift</code> on page 629
Carrier Range (m)	Range of the carrier	<code>[:SOURCE<hw>] :BB:GNSS:LOGGING:CATegory: SATellite:CRANge</code> on page 629
Tropospheric Delay (m)	Tropospheric signal delay	<code>[:SOURCE<hw>] :BB:GNSS:LOGGING:CATegory: SATellite:TDELay</code> on page 629
Ionospheric Delay (m)	Ionospheric signal delay	<code>[:SOURCE<hw>] :BB:GNSS:LOGGING:CATegory: SATellite:IDELay</code> on page 629

Remote command:

`[:SOURCE<hw>] :BB:GNSS:LOGGING:CATegory: SATellite:SElect:ALL`
on page 628

`[:SOURCE<hw>] :BB:GNSS:LOGGING:CATegory: SATellite:SElect:NONE`
on page 628

Logged User Motion Parameters

Selects the parameters to be logged.

Use the "Select All/Deselect All" function to select all or none of the parameters.

Parameter	Description	Remote command
Position (LLA) (deg,deg,m)	Latitude, longitude, altitude of a vehicle in WGS84 coordinates, rad	<code>[:SOURCE<hw>] :BB:GNSS:LOGGING:CATegory:UMOTion[:CSV]:POSition:LLA</code> on page 629
Position (ENU) (m,m,m)	Position of the vehicle in ENU (East, North, Up) Cartesian coordinates	<code>[:SOURCE<hw>] :BB:GNSS:LOGGING:CATegory:UMOTion[:CSV]:POSition:ENU</code> on page 629
Position (ECEF) (m) Velocity (ECEF) (m/s) Acceleration (ECEF) (m/s ²) Jerk (ECEF) (m/s ³)	Position, velocity and acceleration of the vehicle in ECEF (Earth-Centered, Earth-Fixed) coordinates	<code>[:SOURCE<hw>] :BB:GNSS:LOGGING:CATegory:UMOTion[:CSV]:POSition:ECEF</code> on page 629 <code>[:SOURCE<hw>] :BB:GNSS:LOGGING:CATegory:UMOTion[:CSV]:VELocity:ECEF</code> on page 630 <code>[:SOURCE<hw>] :BB:GNSS:LOGGING:CATegory:UMOTion[:CSV]:ACCEleration:ECEF</code> on page 629 <code>[:SOURCE<hw>] :BB:GNSS:LOGGING:CATegory:UMOTion[:CSV]:JERK:ECEF</code> on page 629
Velocity (Local NED) (m/s)		<code>[:SOURCE<hw>] :BB:GNSS:LOGGING:CATegory:UMOTion[:CSV]:VELocity:LNED</code> on page 630
Ground Speed (m/s)	Vehicle speed	<code>[:SOURCE<hw>] :BB:GNSS:LOGGING:CATegory:UMOTion[:CSV]:GSPeED</code> on page 629
Antenna Offset (ECEF) (m)		<code>[:SOURCE<hw>] :BB:GNSS:LOGGING:CATegory:UMOTion[:CSV]:AOFFset</code> on page 629
Altitude (YPR) Altitude Rate (YPR) Altitude Acceleration (YPR) Altitude Jerk (YPR)	Altitude means the HAE (Height Above the Ellipsoid) altitude. Altitude parameters in local geodetic coordinates (Yaw/Heading, Pitch/Elevation, Roll/Bank)	<code>[:SOURCE<hw>] :BB:GNSS:LOGGING:CATegory:UMOTion[:CSV]:ATTitude</code> on page 629 <code>[:SOURCE<hw>] :BB:GNSS:LOGGING:CATegory:UMOTion[:CSV]:ATTitude:JERK</code> on page 629 <code>[:SOURCE<hw>] :BB:GNSS:LOGGING:CATegory:UMOTion[:CSV]:ATTitude:ACCEleration</code> on page 629 <code>[:SOURCE<hw>] :BB:GNSS:LOGGING:CATegory:UMOTion[:CSV]:ATTitude:JERK</code> on page 629
Number of Visible SVs		<code>[:SOURCE<hw>] :BB:GNSS:LOGGING:CATegory:UMOTion[:CSV]:SVS</code> on page 629
GDOP PDOP HDOP VDOP TDOP	Geometric DOP Positional DOP Horizontal DOP Vertical DOP Time DOP	<code>[:SOURCE<hw>] :BB:GNSS:LOGGING:CATegory:UMOTion[:CSV]:GDOP</code> on page 629 <code>[:SOURCE<hw>] :BB:GNSS:LOGGING:CATegory:UMOTion[:CSV]:PDOP</code> on page 629 <code>[:SOURCE<hw>] :BB:GNSS:LOGGING:CATegory:UMOTion[:CSV]:HDOP</code> on page 629 <code>[:SOURCE<hw>] :BB:GNSS:LOGGING:CATegory:UMOTion[:CSV]:VDOP</code> on page 630 <code>[:SOURCE<hw>] :BB:GNSS:LOGGING:CATegory:UMOTion[:CSV]:TDOP</code> on page 630

In HIL scenarios ("Receiver > Position > Remote Control (HIL)"), some parameters are not logged.

Remote command:

`[:SOURCE<hw>] :BB:GNSS:LOGGING:CATEGORY:UMOTION[:CSV]:SELECT:ALL`
on page 628

`[:SOURCE<hw>] :BB:GNSS:LOGGING:CATEGORY:UMOTION[:CSV]:SELECT:NONE`
on page 628

17 Assistance data generation

Equipped with a basic GNSS system option, the R&S SMW200A can generate assistance data for this system. For assistance data time parameters, the R&S SMW200A uses the configured simulation time parameters.

See also [Table 2-1](#) and [Chapter 4.1, "Time settings"](#), on page 46.

The following sections provide information on generating assistance data and assistance data settings.

- [Generating assistance data](#)..... 299
- [Assistance data generation settings](#)..... 300

17.1 Generating assistance data

This step-by-step instruction provides information on how to generate GPS assistance data. Generation of assistance data for other GNSS systems is analogous.

1. Select "GNSS" > "Data Generation".
2. Select "Assistance Data Generation".
3. Set the "Assistance Mode" > "A-GPS".
4. Optionally, set the navigation message type for example "Navigation Data Format" > "LNAV".
5. Select "Synchronize SVs".

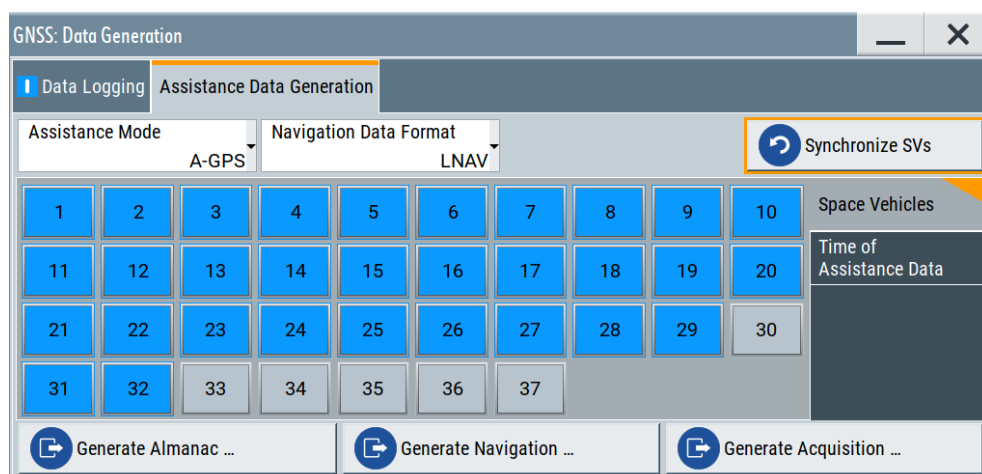

Relevant settings, like present satellites, receiver location or timing information are retrieved automatically but you can change them later. The satellite constellation displays the present satellites in the "Space Vehicles" side tab.

6. To configure assistance data time parameters, select the "Time of Assistance Data" side tab:

- a) Check the displayed parameters for the assistance data timebase, simulation date and simulation time.
These settings are equal to the simulation time settings "Simulation Start", "Date" and "Time", see [Chapter 4.1, "Time settings"](#), on page 46.
- b) Configure the data acquisition duration, for example "Duration" = "1140.08 s".
- c) Configure the data acquisition step interval, for example "Step" = "80 ms".

Start Time	Date	Time	Space Vehicles
UTC	2014-02-19	06:00:00.000	
Acquisition Data Parameters			
Duration	Step		Time of Assistance Data
1 140.080 s	80 ms		

The displayed settings are for UTC timebase. For timebases "GPS", "GST", "BDT" and "NavIC", you can also check the week number and time of week parameters. See also ["Week"](#) on page 306 and ["Time of Week"](#) on page 307

7. To create an assistance data file, select the corresponding data format and file type:
 - a) Select "Generate Almanac ..." to save assistance data for almanac files with extension *.rs_yuma or *.rs_al.
See also ["Generate Almanac"](#) on page 302.
 - b) Select "Generate Navigation ..." to save assistance data for navigation or RINEX files with extension *.rnx, *.<xx>n or *.<xx>g.
See also ["Generate Navigation"](#) on page 303.
 - c) Select "Generate Acquisition ..." to save assistance data for acquisition files with extension *.rs_acq
See also ["Generate Acquisition"](#) on page 303.

With the provided settings, you can generate assistance data files for assisted-GNSS testing.

In a test setup with a protocol tester and a DUT, the generated assistance data files can be formatted into mobile communication message formats. These files can be used to accelerate the time to first fix (TTFF).

17.2 Assistance data generation settings

Access:

1. Select "GNSS" > "Data Generation".
2. Select "Assistance Data Generation".

The tab provides settings to configure settings for assistance data generation.

Settings:

- [General settings](#)..... 301
- [Space vehicle settings](#)..... 305
- [Time of assistance data settings](#)..... 305

17.2.1 General settings

Access:

1. Select "GNSS" > "Data Generation".
2. Select "Assistance Data Generation".

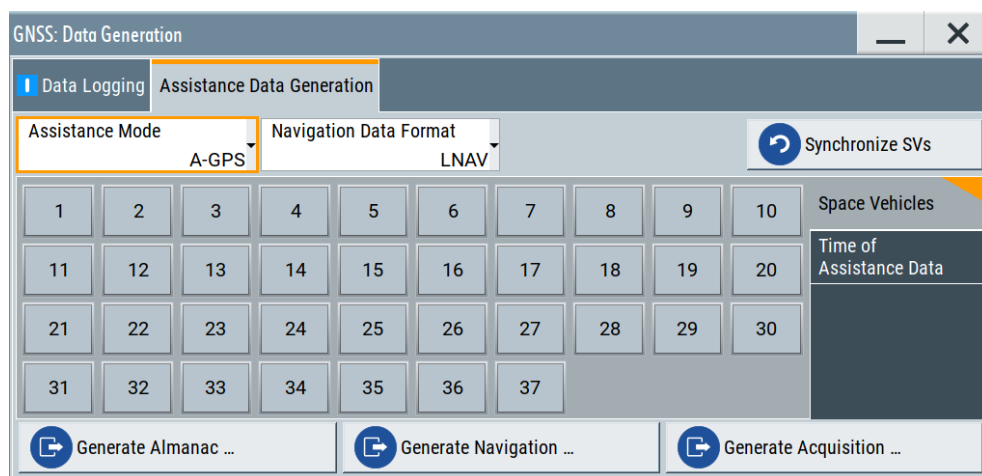

The tab provides settings to configure general settings for assistance data generation.

Settings:

- [Assistance Mode](#)..... 301
- [Navigation Data Format](#)..... 302
- [Synchronize SVs](#)..... 302
- [Generate Almanac](#)..... 302
- [Generate Navigation](#)..... 303
- [Generate Acquisition](#)..... 303

Assistance Mode

Defines the type of assistance data to be loaded.

Selectable values require installation of a GNSS system option, see table below.

Value	Required option
A-GPS	R&S SMW-K44
A-GALILEO	R&S SMW-K66
A-GLONASS	R&S SMW-K94

Value	Required option
A-BeiDou	R&S SMW-K107
A-QZSS	R&S SMW-K106
A-NavIC	R&S SMW-K97

Remote command:

[\[:SOURCE<hw>\]:BB:GNSS:ADGeneration:MODE](#) on page 598

Navigation Data Format

Requires "Assistance Mode" > "A-GPS".

Sets the format of the generated GPS navigation data file.

Remote command:

[\[:SOURCE<hw>\]:BB:GNSS:ADGeneration:NAVigation:DFORmat](#) on page 599

Synchronize SVs

Synchronizes the settings automatically with present satellites in the satellite constellation, receiver location or timing information. During data generation, you can also change these parameters.

Remote command:

[\[:SOURCE<hw>\]:BB:GNSS:ADGeneration:GPS:SYNChronize](#) on page 598

(etc. for the other GNSS systems)

Generate Almanac

Opens the standard "File Select" dialog for file handling.

In this dialog, set the filename. The data format is defined with the parameter [Navigation Data Format](#).

The almanac file is generated in one of the following file formats:

- Comma-separated file format *.rs_al
See [Table 17-1](#).
- Standard Yuma formatted file *.rs_yuma
 - For GPS, Galileo, BeiDou, QZSS and NavIC, you can use the *.rs_yuma almanac file as the main almanac source for the specific GNSS.
 - For GLONASS, this file format is not supported.

Table 17-1: Contents of the generated almanac file (GPS)

Parameter	Unit
SatID	-
e	-
toa	s
delta_i	semicircles
OMEGADOT	semicircles/s
SV Health	Boolean
SQRT(A)	meters

Parameter	Unit
OMEGA0	semicircles
M0	semicircles
w	semicircles
af0	s
af1	s/s

The generated almanac file conforms with the format appended to standards [TS 34.108](#), [TS 51.010-1](#) and [TS 37.571-1](#).

How to: [Chapter 17.1, "Generating assistance data"](#), on page 299

Remote command:

`[:SOURCE<hw>] :BB:GNSS:ADGeneration:ALManac:CREate` on page 603

Generate Navigation

Opens the standard "File Select" dialog.

Set the filename and file extension. The generated navigation file conforms with RINEX file formats, see [Table B-1](#).

Navigation data comprises the ephemeris page of each satellite for the selected time of assistance data.

How to: [Chapter 17.1, "Generating assistance data"](#), on page 299

Remote command:

`[:SOURCE<hw>] :BB:GNSS:ADGeneration:NAVigation:CREate` on page 603

Generate Acquisition

Opens the standard "File Select" dialog to create an acquisition file.

Define the filename and save the file. The firmware assigns the file extension `.rs_acq` automatically.

The acquisition file consists of:

- One or more rows, each corresponding to the time parameter listed in [Table 17-2](#).
The number of generated rows is calculated as follows:
Number of generated rows = "Duration Of Assistance Data" / "Resolution of Assistance Data"
- One or more sequential acquisition blocks per row, where each block comprises the parameters listed in [Table 17-3](#).
The number of the acquisition blocks depends on the number of enabled space vehicles.

The generated acquisition file conforms with the format as specified for standards [TS 34.108](#), [TS 51.010-1](#) and [TS 37.571-1](#).

Table 17-2: Time parameter

GNSS	Parameter	Description	Unit
All except GLONASS	GNSS TOW	Receiver referenced GNSS time of week All except GLONASS: GPS, Galileo, Bei-Dou, QZSS, NavIC	s
GLONASS	Time of Validity	Elapsed time relative to GLONASS time of assistance data	ms

Table 17-3: Acquisition block (one sequence)

GNSS	Parameter	Description	Unit
All	SVID/PRNID	Satellite ID that corresponds to the record	-
All	Doppler (0th order term)	Zero order Doppler term	m/s
All	Doppler (1st order term)	First order Doppler term	m/s ²
All	Doppler Uncertainty	Uncertainty of the Doppler shift	m/s
All	Code Phase	Code phase Or half-Chip index at epoch Time of Transmission (GPS Sat Time)	Chips (GPS) ms (non-GPS)
All	Integer Code Phase	Integer code phase Or ms unit index at epoch Time of Transmission (GPS Sat Time)	CA periods (GPS) ms (non-GPS)
All	Code Phase Search Window	Correlation code phase search radius	Chips (GPS) ms (non-GPS)
All	Azimuth	Azimuth angle of the satellite in the ENU coordinate system centered at the reference point	deg
All	Elevation	Elevation angle of the satellite in ENU coordinate system centered at reference point	deg

How to: [Chapter 17.1, "Generating assistance data"](#), on page 299

Remote command:

`[:SOURce<hw>] :BB:GNSS:ADGeneration:ACQuisition:CREate` on page 602

17.2.2 Space vehicle settings

Access:

- ▶ Select "Assistance Data Generation" > "Space Vehicles".

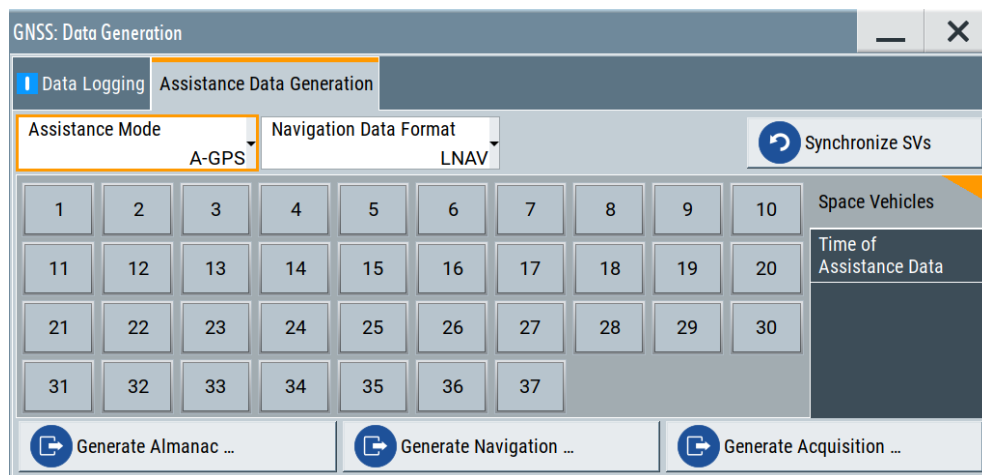

The tab provides settings to enable or disable space vehicles for assistance data generation.

Settings:

Space Vehicles

Displays the space vehicles (SV) that are part of the current satellites constellation. Highlighted SV ID are included in the generated assistance data.

To retrieve the SV IDs of the present satellites in the constellation, select "Synchronize SVs". To redefine the included SV IDs, toggle its state.

Remote command:

[:SOURCE<hw>] :BB:GNSS:ADGeneration:GPS:SVID<ch>:STATE on page 599 (etc. for the other GNSS systems)

17.2.3 Time of assistance data settings

Access:

- ▶ Select "Assistance Data Generation" > "Space Vehicles".

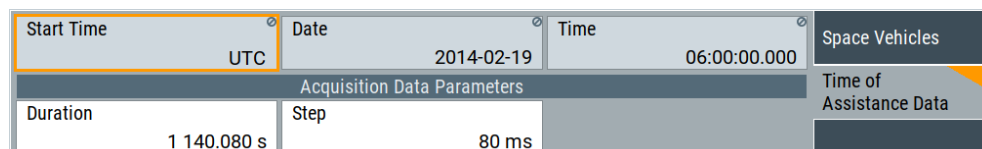

The tab provides settings to configure the time-related parameters for the assistance data generation.

Start Time.....	306
Date.....	306
Time.....	306
Week.....	306
Time of Week.....	307
Duration.....	307
Step.....	307

Start Time

Displays the timebase for the assistance data as configured in the simulation time settings.

See also "[Simulation Start](#)" on page 48.

Remote command:

`[:SOURCE<hw>] :BB:GNSS:ADGeneration:GPS:TOAData:TBASis?` on page 599
(etc. for the other GNSS systems)

Date

Requires "Start Time" > "UTC" or "GLO".

Displays the date for the assistance data as configured in the simulation time settings. The date applies to the Gregorian calendar in format YYYY-MM-DD (ISO 8601).

See also "[Date / Week, Time / Time of Week /s, UTC Offset /s](#)" on page 50.

Remote command:

`[:SOURCE<hw>] :BB:GNSS:ADGeneration:GPS:TOAData:DATE?` on page 600
(etc. for the other GNSS systems)

Time

Requires "Start Time" > "UTC" or "GLO".

Displays the simulation time for the assistance data generation in time format HH.MM.SS.xxx.

See also "[Date / Week, Time / Time of Week /s, UTC Offset /s](#)" on page 50.

Remote command:

`[:SOURCE<hw>] :BB:GNSS:ADGeneration:GPS:TOAData:TIME?` on page 600
(etc. for the other GNSS systems)

Week

Requires "Start Time" > "GPS", "GST", "BDT" or "NavIC".

Displays the week number (WN) for the assistance data generation as configured in the simulation time settings.

See also "[Date / Week, Time / Time of Week /s, UTC Offset /s](#)" on page 50.

Remote command:

`[:SOURCE<hw>] :BB:GNSS:ADGeneration:GPS:TOAData:WNUMBER?`
on page 602
(etc. for the other GNSS systems)

Time of Week

Requires "Start Time" > "GPS", "GST", "BDT" or "NavIC".

Displays the Time of Week (TOW) for the assistance data generation as configured in the simulation time settings.

See also "[Date / Week, Time / Time of Week /s, UTC Offset /s](#)" on page 50.

Remote command:

`[:SOURCE<hw>] :BB:GNSS:ADGeneration:GPS:TOADData:TOWeek?` on page 602
(etc. for the other GNSS systems)

Duration

Sets the duration of the assistance data generation.

Remote command:

`[:SOURCE<hw>] :BB:GNSS:ADGeneration:GPS:TOADData:DURATION`
on page 601
(etc. for the other GNSS systems)

Step

Sets the time resolution of the assistance data generation.

Remote command:

`[:SOURCE<hw>] :BB:GNSS:ADGeneration:GPS:TOADData:RESolution`
on page 601
(etc. for the other GNSS systems)

18 Loading constellation and navigation message data

The default satellite's constellation and the navigation message are extracted from official navigation source files and emulates the GNSS navigation system at 9 February 2016 at 06:00:00 am.

Internal algorithms use the predefined navigation source information and predict the satellite's constellation and the navigation messages at any given moment of time. For most test cases, the prediction is sufficient.

Applications

Load constellation data and navigation data for any of the GNSS systems separately. Use loaded data to simulate a realistic GNSS signal or to reproduce a historical satellite constellation.

Loading user-defined constellation is useful, if the HDOP and PDOP values exceed your specific limits. To observe current values, select "GNSS" > "Simulation Monitor" > "Sky View".

File formats

Supported are constellation and navigation message files in the following formats:

- GPS: YUMA, SEM, TXT or RINEX files
See:
 - ["YUMA, SEM and XML file download"](#) on page 308
 - ["RINEX file download"](#) on page 309
- Galileo: XML
See ["YUMA, SEM and XML file download"](#) on page 308
- GLONASS and QZSS: AGL, YUMA and XML
See ["YUMA, SEM and XML file download"](#) on page 308
- BeiDou: ALC
See ["YUMA, SEM and XML file download"](#) on page 308
- SBAS: *.ems or *.nstb
See ["SBAS correction file download"](#) on page 309

YUMA, SEM and XML file download

You can download YUMA, SEM and XML files via the Internet. Transfer them to the R&S SMW200A and load them if necessary.

Use, for example, the following sources:

- US Coast Guard Navigation Center GPS Homepage
<https://www.navcen.uscg.gov/archives>
Provides YUMA (xxx.alm) and SEM (xxx.al3 files, where xxx denotes the day of a year
- <https://www.celestrak.com/GPS/almanac/>

Provides `almanac.sem/yuma.weekXXXXX.YYYYYY.txt` files, where `xxxx` denotes the GPS week and `YYYYYY` the time of almanac (TOA)

- European GNSS Service Center (GSC) Galileo almanac file repository <https://www.gsc-europa.eu/product-almanacs>
Provides XML (`zzzz-yy-xx.xml`) files, where `zzzz`, `yy` and `xx` denote year, month and day.
- <ftp://ftp.glonass-iac.ru/MCC/ALMANAC/>
GLONASS files `xxx.agl`
- Test and Assessment Research Center (TARC) of China Satellite Navigation Office (CSNO) BeiDou almanac file server <ftp://59.252.100.32/almanac/>
Provides ALC files `tarc0xxx0.zzalc`, where `xxx` denotes the file number and `zz` the year. For example, `*.19alc` files contain almanac data from the year 2019. The file number is approximately the day of the year, but can deviate. The ALC file format is similar to the YUMA file format.
- Japanese Space Agency homepage <https://qz-vision.jaxa.jp/USE/en/almanac>
Provides QZSS or QZSS+GPS YUMA (`zzyyyyxxx.alm`) or XML (`zzyyyyxxx.alm.xml`) files, where `zz=q` indicates the QZSS and `zz=qg` the QZSS+GPS files; `yyyy` denotes the year and `xxx` the day of a year.

For detailed information on the content and frame structure of navigation data, refer to the specifications.

RINEX file download

RINEX files are standard formats generated by control stations (CS) and many commercial receivers. RINEX navigation files usually comprise the ephemeris sets for several satellites with different TOE and TOC. One RINEX file is enough to describe satellite orbits for a period longer than two hours and sometimes up to one day.

Use, for example, the following sources:

- <https://cdsis.nasa.gov/archive/gnss/data/daily/>
- <ftp://ftp.glonass-iac.ru/MCC/BRDC>
- <https://qz-vision.jaxa.jp/USE/en/ephemeris>

Provided are `*.rnx` or `*.<xx>n`, where `<xx>` denotes the year in two-digit format. See also [Chapter B, "RINEX files"](#), on page 666.

SBAS correction file download

The `*.ems` and `*.nstab` files are files with augmentation messages broadcast by EGNOS and WAAS.

You can find files in this format at:

- EGNOS message server (EMS): <http://www.egnos-pro.esa.int/ems/index.html>
The provided files are hierarchy grouped per PRN (PRN#), per year (y#), per day (d#) and per hour (h#). Each EMS file contains information on one PRN for the time span of one hour.

Correction data is extracted from one of the loaded files; the exact PRN is configurable.

- <http://www.nstb.tc.faa.gov/DisplayNSTBDataDownload.htm>.
Provided are files from different control stations. The files are grouped per day, where each file contains information on several PRNs for the time span of 24 hours.
The downloaded files do not have an extension. Add the extension *.nstb manually.
- [Import constellation settings](#).....310
- [Import SBAS settings](#).....312

18.1 Import constellation settings

Access:

1. Select "GNSS" > "Simulation Configuration" > "Satellites".
2. In the side tab, select the GNSS system, for that you want to import a satellite constellation.
3. Select "Import Constellation".
4. Select "Constellation Source File", to load a constellation source file.
For GPS, for example, load a RINEX file with file extension *.rnx.

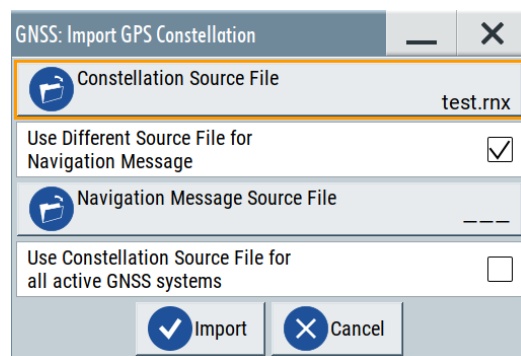

The filename of the last imported file is displayed on the button accessing the standard "File Select" dialog.

5. Optionally, use a different data source for the navigation message.
6. Optionally, apply the specifications in the source file for all active GNSS systems.
7. Select "Import".
Triggers extracting the data, the satellite constellation and the navigation changes as specified in the file.

Settings:

Constellation Source File.....	311
Use Different Source File for Navigation Message.....	311
Navigation Message Source File.....	311
Use Constellation Source File for all active GNSS system.....	311
Import, Cancel.....	311

Constellation Source File

Selects the file from that the satellites constellation and navigation data are extracted.

Simulation data (i.e. the almanac part of the navigation message) and the navigation data per SV ID (i.e. ephemeris) can be extracted from the same or from different files. Supported are almanacs and RINEX files, in any of the standard formats for these files.

For an overview of supported file types, see [Table 22-1](#).

Remote command:

`[:SOURCE<hw>] :BB:GNSS:SV:IMPORT:GPS:FILE:CONSTellation` on page 446
(etc. for the other GNSS systems)

Use Different Source File for Navigation Message

Loads a dedicated file as source for the navigation data.

Per default, navigation data is extracted from the same file that is used as source for the simulation (satellite constellation).

Remote command:

`[:SOURCE<hw>] :BB:GNSS:SV:IMPORT:GPS:UDSource` on page 447
(etc. for the other GNSS systems)

Navigation Message Source File

Selects the file from that the navigation data is extracted.

Use this function, if navigation data differs from the constellation file. For overview of the supported file types, see [Table 22-1](#).

Remote command:

`[:SOURCE<hw>] :BB:GNSS:SV:IMPORT:GPS:FILE:NMEsage` on page 447
(etc. for the other GNSS systems)

Use Constellation Source File for all active GNSS system

Requires RINEX files version 3.x or later, see [Table B-1](#).

Applies extracted data from the constellation source to all active GNSS.

Use this function when importing comprehensive constellation source files covering data for several GNSS. If you have a defined constellation of an active GNSS and the file has no constellation data for this GNSS, the constellation of this GNSS is deactivated.

Remote command:

`[:SOURCE<hw>] :BB:GNSS:SV:IMPORT:GPS:FILE:NMEsage` on page 447
(etc. for the other GNSS systems)

Import, Cancel

Triggers the import or discards the selected files.

Remote command:

[:SOURCE<hw>] :BB:GNSS:SV:IMPort:GPS:EXECute on page 448
 (etc. for the other GNSS systems)

18.2 Import SBAS settings

Access:

1. Select "GNSS" > "Simulation Configuration" > "System & Signals".
2. Select "System" > "SBAS" > "On".
3. Select "Import Constellation/Import Constellation and Correction Data".
4. Select "Add File" or "Add Directory".

You can add predefined files or load a specific constellation. For example, for importing EGNOS system data, load *.ems files.

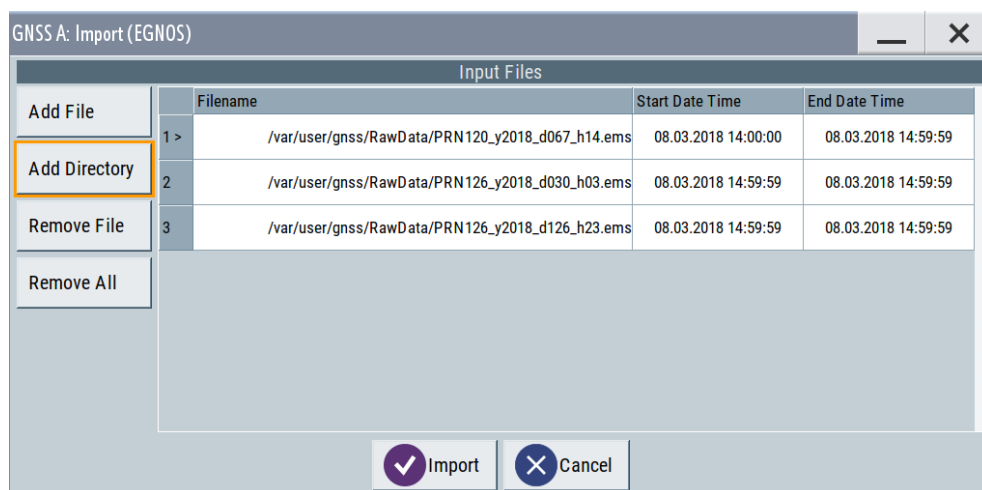

5. Select "Import".

The dialog provides standard file handling functions.

Settings:

Add File.....	312
Add Directory.....	313
Remove File, Remove All.....	313
Input Files.....	313
Import, Cancel.....	313

Add File

Selects a predefined or user-defined file.

Supported are files defined in "SBAS correction file download" on page 309.

Remote command:

[:SOURce<hw>] :BB:GNSS:SV:IMPORt:SBAS:EGNOS:ADD:FILE on page 583

[:SOURce<hw>] :BB:GNSS:SV:IMPORt:SBAS:WAAS:ADD:FILE on page 583

Add Directory

Selects a set of files in one step.

Remote command:

[:SOURce<hw>] :BB:GNSS:SV:IMPORt:SBAS:EGNOS:ADD:DIR on page 583

[:SOURce<hw>] :BB:GNSS:SV:IMPORt:SBAS:WAAS:ADD:DIR on page 583

Remove File, Remove All

Remove a file or all files from the list.

Remote command:

[:SOURce<hw>] :BB:GNSS:SV:IMPORt:SBAS:EGNOS:REMOve:FILE<ch>

on page 585

[:SOURce<hw>] :BB:GNSS:SV:IMPORt:SBAS:WAAS:REMOve:FILE<ch>

on page 585

[:SOURce<hw>] :BB:GNSS:SV:IMPORt:SBAS:EGNOS:REMOve:ALL on page 584

[:SOURce<hw>] :BB:GNSS:SV:IMPORt:SBAS:WAAS:REMOve:ALL on page 584

Input Files

When a file is loaded, its "Filename" and "Start/End Date and Time" are retrieved and displayed.

Remote command:

[:SOURce<hw>] :BB:GNSS:SV:IMPORt:SBAS:EGNOS:LIST? on page 584

[:SOURce<hw>] :BB:GNSS:SV:IMPORt:SBAS:WAAS:LIST? on page 584

Import, Cancel

Loads the files or aborts the import action.

Remote command:

[:SOURce<hw>] :BB:GNSS:SV:IMPORt:SBAS:EGNOS:EXECute on page 584

[:SOURce<hw>] :BB:GNSS:SV:IMPORt:SBAS:WAAS:EXECute on page 584

19 Hardware in the loop (HIL)

The term hardware in the loop (HIL) describes the mode in which the R&S SMW200A is remotely controlled by control application software (see [Figure 19-1](#)). The control application software sends remote commands over LAN in real time, possibly from a motion simulator. The R&S SMW200A processes the received position, motion and attitude information and generates the required signal.

The output GNSS signal is sent to system under test, that typically includes a GNSS receiver forwarding the calculated position to the application software. The application software can use the retrieved position for display purposes (such as infotainment platform in a vehicle) or to control the actual position of the vehicle (e.g. auto-pilot).

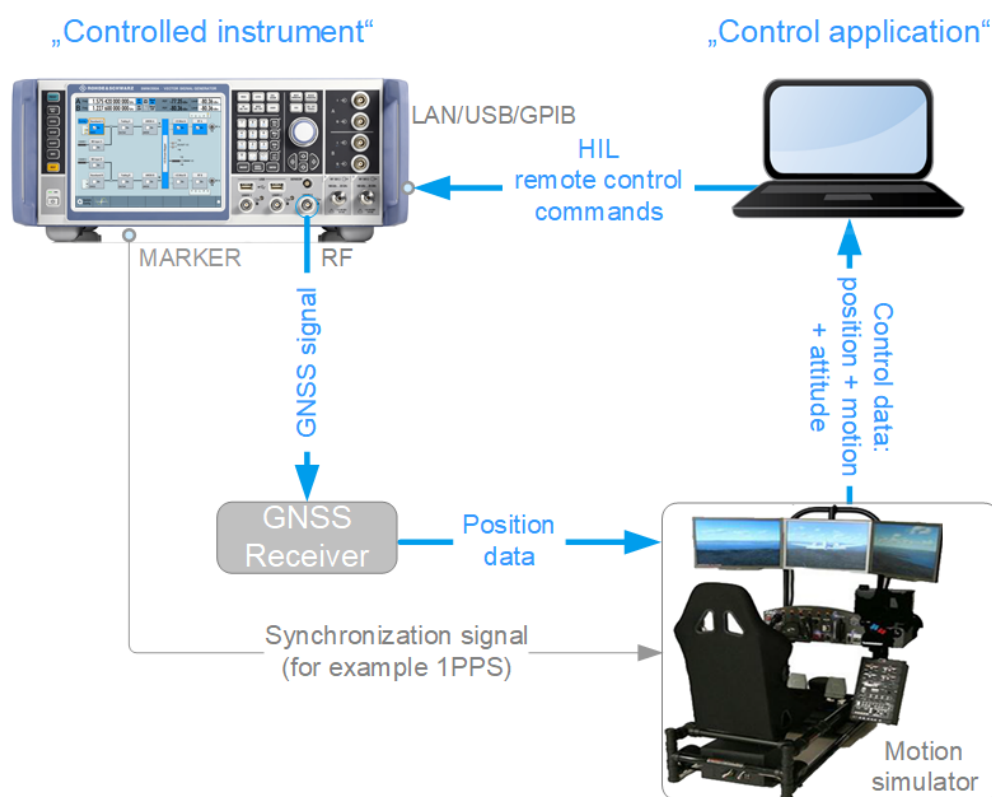

Figure 19-1: Example of HIL test setup

Refer to the following sections, for definition of the terms used in the context of HIL testing and settings. The description also gives recommendations on working with the R&S SMW200A in HIL setups.

- [Tips for best results](#)..... 315
- [HIL settings](#)..... 321
- [UDP position data](#)..... 327
- [SCPI position data](#)..... 328
- [Remote-control commands](#)..... 329

19.1 Tips for best results

We recommend that you consider the following measures.

Measures for proper operation

1. Synchronize the R&S SMW200A and the motion simulator.
(see [Chapter 19.1.1, "Synchronization"](#), on page 315).
2. Take measures for latency calibration.
(see [Chapter 19.1.3, "Latency calibration"](#), on page 316).
3. Add additional buffer time.
[Chapter 19.1.4, "Adding a constant delay to compensate for command jitter"](#), on page 318
4. If the first position fix and the [latency calibration](#) are successful but during the motion simulation the receiver loses its position fix, try out the following:
 - a) Analyze the sent HIL data.
 - Evaluate the trajectory smoothness and search in particular for unwanted abrupt positions changes ("jumps").
 - Send HIL commands with lower update rate, for example each 100 ms. Reducing the update rate leads to interpolation and thus spreads the severity of the "jumps" over several 10 ms update intervals.
See [Chapter 19.1.5, "Interpolation"](#), on page 320.
 - b) Avoid abrupt positions changes.
The motion simulator itself can cause position changes. Consult the specification of the used receiver for information on the high-order dynamic stress it is able to handle.



The [measures for proper operation](#) use the SCPI interface and the R&S SMW200A is in remote state. Switch to manual state after you finish the measures, if the R&S SMW200A retrieves HIL position data via [UDP](#) packets.

19.1.1 Synchronization

To process the HIL commands, the R&S SMW200A uses its internal 100 Hz clock signal, that corresponds to a time resolution of 10 ms.

The motion simulator uses its own clock. Depending on the capabilities of the processor (general purpose or real time) that the motion simulator uses, the processing time and the accuracy of the clock can vary. The R&S SMW200A internal clock signal is precise and stable. This clock is not only used to generate the GNSS signals but is also the time reference for the whole HIL setup.

We recommend that you synchronize the motion simulator to the R&S SMW200A. Consider the following:

- Follow the rules described in ["Measures for proper operation"](#) on page 315

- Always take the measures for latency calibration as described in [Chapter 19.1.3, "Latency calibration"](#), on page 316.
- If your motion simulator can receive and process the marker signal of the R&S SMW200A, generate a 1PPS (one pulse per second) or 10PPS (10 pulses per second) marker signal. Feed the marker signal to the motion simulator. If synchronized, the motion simulator sends the HIL commands right after each 1PPS marker signal.

Related settings:

- "GNSS > Marker > Marker Mode"
(see ["Mode"](#) on page 344)

19.1.2 System latency

System latency is a term that describes the time it takes the R&S SMW200A to receive and process an incoming HIL command, calculate, output and transmit the signal to the GNSS receiver. The **default system latency is 20 ms**; this value corresponds to the R&S SMW200A hardware processing time.

In the context of this description, the term latency ($t_{\text{cal.latency}}$) describes the **additional latency (i.e. delay)** caused, for example, by the transmission and processing time of the HIL commands. If the system latency value is a constant parameter that cannot be reduced, the additional latency $t_{\text{cal.latency}}$ is a variable value, that can be partly or fully compensated. This description focuses on the measures to measure and compensate for additional latency.

You can query the additional latency value as described in [Chapter 19.1.3, "Latency calibration"](#), on page 316. The system latency and the latency are related as follows:

$$\text{System Latency} = t_{\text{cal.latency}} + 0.02$$

The minimum system latency of the HIL setup is 2 ms and is achieved if the $t_{\text{cal.latency}} = 0$ ms. The situation when $t_{\text{cal.latency}} = 0$ ms is referred as a zero latency situation; it is also the best case scenario.

See also:

- [Chapter 19.1, "Tips for best results"](#), on page 315
- ["Understanding the response of the query SOURce:BB:GNSS:RT:RECeiver1:HIL-Position:LATency:STATistics?"](#) on page 329

19.1.3 Latency calibration

Latency calibration is the process of compensating the latency time. Calibrate the latency at the beginning of the simulation and repeat the process periodically, every 5 or 10 seconds.

Initial latency calibration process

1. **Synchronize the R&S SMW200A and the motion simulator.**
(see [Chapter 19.1.1, "Synchronization"](#), on page 315).

2. Set the same **initial position (P_0)** in both the motion simulator and the R&S SMW200A.
The initial position is the position in the moment t_0 .
In R&S SMW200A, set the receiver position with the parameters "Receiver Position > Location Coordinates".
Tip: We recommend that you use the position that you are going to use as the first simulation position in the motion simulation.
3. Wait until the GNSS receiver performs its **first position fix**.
4. **Retrieve an initial time reference** information from the R&S SMW200A.
Send the command `[:SOURce<hw>] :BB:GNSS:RT:HWTTime?` to query the elapsed time from the simulation begin ($\Delta_{HW,0}$).
The response is a value that reflects the difference between the current time in the R&S SMW200A ($t_{GNSS,0}$) and the motion simulator ($t_{MS,0}$) at the moment t_0 :
$$\Delta_{HW,0} \approx t_{MS,0} - t_{GNSS,0}$$
Note: The retrieved value is a rough estimation. It does not consider the round-trip time of the HIL commands.
Although not exact, the response of the command is suitable for the initial time alignment (first approximation).
The precise calibration is performed with the next steps.
5. **Send the first HIL command as a function of the moment $t_{MS,1}$.**
HIL commands define position P_i at a given moment of time $t_{ElapsedTime,i}$.
To compensate for the time difference between the R&S SMW200A and the motion simulator, correct the $t_{ElapsedTime,i}$ value:
 - a) Calculate the first elapsed time $t_{ElapsedTime,1}$
$$t_{ElapsedTime,1} = t_{MS,1} - \Delta_{HW,0}$$
 - b) Use the coordinates of the initial position P_0
 - c) Send a remote command containing the timestamp with position and attitude information.
If you use **UDP packets**, send the command `>L` first and then send the UDP packets.
If you use SCPI commands, send the command depending on the position coordinates:
`[:SOURce<hw>] :BB:GNSS:RT:RECeiver[:V<st>]:HILPosition:MODE:A` for position data in ECEF coordinates.
`[:SOURce<hw>] :BB:GNSS:RT:RECeiver[:V<st>]:HILPosition:MODE:B` for position data in NED coordinates.
6. **Query the time difference ($t_{cal.latency,i}$)** between the elapsed time in the R&S SMW200A ($t_{HW,j}$) and the elapsed time in the last HIL command ($t_{ElapsedTime,i}$).
Send the command `[:SOURce<hw>] :BB:GNSS:RT:RECeiver[:V<st>]:HILPosition:LATency:STATistics?`.

The query returns several parameters and statistical information. For more information, see the description of the remote command.

Observe the value $t_{\text{cal.latency},1} = t_{\text{HW},0} - t_{\text{ElapsedTime},1}$.

If UDP is used, send the `>L` command after the query.

7. If $t_{\text{cal.latency},i} \geq |\text{System Latency} - 20 \text{ ms}|$, perform the following:

a) Calculate $\Delta_{\text{HW},j} = \Delta_{\text{HW},j-1} + t_{\text{cal.latency},i}$

Where:

- i reflects the HIL update rate
- j is the latency calibration iteration number

b) Calculate the elapsed time $t_{\text{ElapsedTime},i+1} = t_{\text{MS},i+1} - \Delta_{\text{HW},j}$

c) Send the subsequent HIL command as a function of $t_{\text{MS},i+1}$ and P_i

The latency is **successfully calibrated**, if *one of the following is true*:

- $-10 \text{ ms} < \langle \text{MinLatency} \rangle < \langle \text{MaxLatency} \rangle < 10 \text{ ms}$
- $\langle \text{CmdReceived} \rangle = \langle \text{CmdSync} \rangle + \langle \text{CmdInterp} \rangle$
- $\langle \text{MinUsed} \rangle_{\text{min}} \geq 1$

Where $\langle \text{MaxLatency} \rangle$, $\langle \text{MinLatency} \rangle$, $\langle \text{MinUsed} \rangle$, $\langle \text{CmdReceived} \rangle$,

$\langle \text{CmdSync} \rangle$ and $\langle \text{CmdInterp} \rangle$ are the value returned by the query [:

`SOURce<hw>]:BB:GNSS:RT:RECeiver[:V<st>]:HILPosition:LATency:STATistics?`.

If UDP is used, send the `>L` command.

A latency of 0 ms corresponds to a system latency of 20 ms.

If the **latency calibration is unsuccessful**:

- **Add a buffer time**, see [Chapter 19.1.4, "Adding a constant delay to compensate for command jitter"](#), on page 318.
- Query HIL statistical information and **analyze** the values of the parameters $\langle \text{CmdExtrap} \rangle$ and $\langle \text{CmdPredict} \rangle$.

They indicate the number of times the prediction algorithm has been applied, see [Chapter 19.1.6, "Trajectory prediction"](#), on page 320.

19.1.4 Adding a constant delay to compensate for command jitter

If the motion simulator is not equipped with a real-time processor, it can happen that it sends the HIL commands with varying update rate. This effect is often referred as a command jitter.

The R&S SMW200A can compensate command jitter in the range of 1 ms to 30 ms.

The mechanism is to add a buffer time t_{Buffer} so that the R&S SMW200A has enough time to process and realign the HIL commands. The drawback of this mechanism is the adding of an extra constant delay to the system.

Adding buffer time (t_{Buffer})

To compensate for the command jitter:

- ▶ Send the command `[:SOURce<hw>] :BB:GNSS:RECeiver[:V<st>] :HIL:SLATency`.

The command sets the system latency, i.e. a delay t_{Delay} . The additional buffer time t_{Buffer} is calculated as follows:

$$t_{\text{Buffer}} = t_{\text{Delay}} - 0.02$$

Where t_{Buffer} is the additional time available for processing.

The value 0.02 s is the hardware processing time of the R&S SMW200A.

If the value $t_{\text{Buffer}} > 0$ ms, the system latency equation changes as follows:

$$\text{System Latency} = t_{\text{cal.latency}} + t_{\text{Delay}} = t_{\text{cal.latency}} + t_{\text{Buffer}} + 0.02$$

Finding out the best system latency value t_{Delay}

1. Select the **initial** t_{Delay} value depending on whether the motion simulator is equipped with real-time processor or not:
 - With real-time processor: $\langle \text{Delay} \rangle = 0.02$ s
 - Without real-time processor: $\langle \text{Delay} \rangle = 0.15$ s
2. Collect statistical information with the query `[:SOURce<hw>] :BB:GNSS:RT:RECeiver[:V<st>] :HILPosition:LATency:STATistics?` for at least 30 min.
3. Evaluate the absolute minimum value returned for the parameter $\langle \text{MinUsed} \rangle$.
4. **Reduce the t_{Delay} value.** Evaluate the statistics again.
Repeat this step until $\langle \text{MinUsed} \rangle_{\text{min}} \geq 1$.

Example:

If the R&S SMW200A and the motion simulator are connected in a HIL setup and:

- HIL update rate = 0.1 s
- $t_{\text{Delay}} = 0.05$ s
- $t_{\text{Buffer}} = 0.03$ s.
- In a *non-synchronized* setup with, for example, $t_{\text{cal.latency}} = 0.04$ s, the current system latency is:
System Latency = $0.04 + 0.05 = 0.09$ s
- After the R&S SMW200A and the motion simulator are *synchronized* ($t_{\text{cal.latency}} = 0$ s), the system latency becomes:
System Latency = $0 + 0.05 = 0.05$ s
With the buffer time of 0.03 s, R&S SMW200A tolerates command jitter of up to 0.03 s.
Because of the buffer time, prediction is not applied.



Adding of buffering time does not substitute the latency calibration. It is an add-on to it.

Always calibrate the latency as described in [Chapter 19.1.3, "Latency calibration"](#), on page 316.

Related settings:

- [Chapter 19.1.2, "System latency"](#), on page 316

19.1.5 Interpolation

If the update rate of the HIL commands is less than 100 Hz, the instrument interpolates the two last received commands to achieve the required update rate. Interpolation can be applied if the system latency is higher than the update rate and if at least one HIL command was received and buffered. The former situation is present, if the query `[:SOURCE<hw>] :BB:GNSS:RT:RECEIVER[:V<st>]:HILPosition:LATency:STATistics?` returns `<MinUsed> = 1`.

The interpolation mechanism can achieve a continuous signal and hence results in better result than the extrapolation and the prediction methods (see [Chapter 19.1.6, "Trajectory prediction"](#), on page 320).

19.1.6 Trajectory prediction

The R&S SMW200A tries to compensate for the latency ($t_{\text{cal.latency}}$) by applying a prediction algorithm. If the R&S SMW200A and the motion simulator are synchronized and the latency is less than 10 ms, prediction is not applied. If the latency exceeds 10 ms, prediction is applied. The R&S SMW200A uses the last received high-order dynamics (speed, acceleration and jerk) and predicts or extrapolates the position of the motion simulator at the subsequent update time.

Where:

- Extrapolation describes the process, where the position is calculated from a received command with an old timestamp and is based on the received speed, acceleration and jerk
- Prediction is applied if no command was received, for example if the update period is larger than 10 ms. When predicted, subsequent positions are calculated based on the last known speed, acceleration and jerk

Retrieving the number of automatically performed extrapolations and predictions

You can query statistical information on the number of times the R&S SMW200A applied predictions or extrapolation with the command `[:SOURCE<hw>] :BB:GNSS:RT:RECEIVER[:V<st>]:HILPosition:LATency:STATistics?`.

Observe the values of the parameters `<CmdExterp>` and `<CmdPredict>`.

Example: How extrapolation can impair the results

Imagine that at the moment t_0 a vehicle is moving with a velocity $v = 1 \text{ m/s}$ and it stops ($v = 0 \text{ m/s}$) after 0.1 s ($t_1 = t_0 + 0.1 \text{ s}$).

If the latency exceeds 10 ms, then the R&S SMW200A projects the movement assuming that the vehicle keeps its velocity $v = 1 \text{ m/s}$. This result of position offset of 0.01 m.

At the next update period, for example 100 ms later, the R&S SMW200A receives the subsequent command and the correct velocity $v = 0 \text{ m/s}$. The instrument corrects the position and removes the 0.01 m position offset.

This causes an abrupt change (a "jump") between the two consecutive positions.

As illustrated in the example, the prediction algorithm alone cannot assure that the trajectory is continuous. Without further measures, the predicted positions can cause abrupt changes between consecutive positions or lead to tracking loss of the GNSS signal. The severity of these abrupt changes depends on both the latency value and the current dynamics and therefore are tolerated or not by the GNSS receiver.

Prediction for instance is useful, if the application requires low latency and tolerates "jumps". Otherwise, we recommend that you use real-time PC with synchronized marker or add buffer to increase the system latency.

See [Chapter 19.1, "Tips for best results"](#), on page 315.

19.2 HIL settings

Option: R&S SMW-K109

Access:

1. Select "GNSS" > "Simulation Configuration" > "Receiver".
2. Select "Position" > "Remote Control (HIL)".
3. Select "Position Configuration".

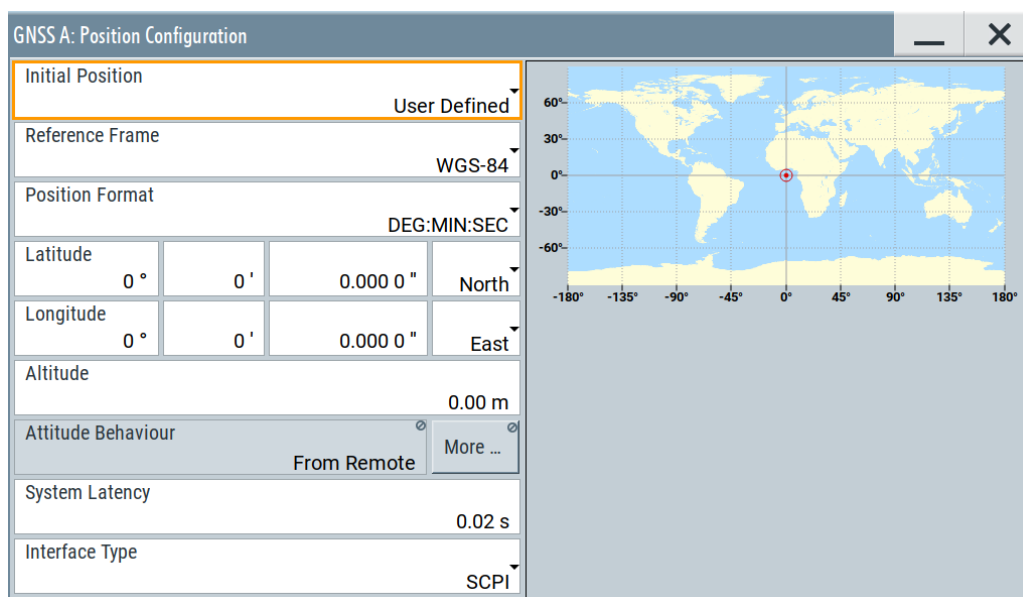

Settings

Location, Initial Position..... 322

Reference Frame..... 324

Location Coordinates, Position Format..... 324

Attitude Behaviour..... 325

System Latency..... 326

Interface Type..... 326

UDP Port..... 327

Location, Initial Position

Selects the location or initial position depending on the simulated object:

- Static GNSS receiver ("Position > Static"): Selects the geographic location of the GNSS receiver.
- R&S SMW-K109: Hardware in the loop (HIL) GNSS receiver ("Position > From Remote"): Selects the initial position of the GNSS receiver.
- R&S SMW-K122: Real-time kinematics (RTK) base station: Selects the geographic location of the RTK base station.

The representation of the coordinates depends on the selected "Reference Frame" and "Position Format".

"User Defined" Sets the receiver position in terms of "Latitude", "Longitude" and "Altitude"

"City" Selects a predefined geographic location, see [Table 5-1](#) for an overview.
The parameters "Latitude", "Longitude" and "Altitude" are set automatically.

Table 19-1: Coordinates of the simulated predefined positions

Continent	City	Latitude [deg]	Longitude [deg]	Altitude [m]
Europe	London	51.500625	-0.1246219	22
	Moscow	55.7522222	37.6155556	200
	Munich	48.15	11.5833333	508
	Paris	48.8584	2.2946278	66
America	New York	40.714667	-74.0063889	1
	San Francisco	37.8194389	-122.4784939	35
	Anchorage	61.2166667	-149.8833333	115
	Mexico City	19.4510539	-99.1255189	2310
	Bogota	4.7111111	-74.0722222	2640
	Sao Paulo	-23.5337731	-46.62529	760
	Santiago de Chile	-33.4474869	-70.6736758	522
Asia	Beijing	39.9055556	116.3913889	60
	New Delhi	28.6138889	77.2088889	77
	Seoul	37.5514997	126.9877939	265
	Singapore	1.3113108	103.8268528	110
	Taipei	25.0223439	121.5147581	10
	Tokyo	35.6838611	139.7450581	45
Africa	Cairo	30.0444419	31.2357117	23
	Dakar	14.7166769	-17.4676858	22
	Cape Town	-33.9188611	18.4233	6
Australia	Sydney	-33.8833333	151.2166667	3
	Perth	-31.9535119	115.8570481	2

Remote command:

`[:SOURCE<hw>] :BB:GNSS:RECEIVER [:V<st>] :LOCATION:CATALOG`
on page 382

`[:SOURCE<hw>] :BB:GNSS:RECEIVER [:V<st>] :LOCATION[:SELECT]`
on page 383

`[:SOURCE<hw>] :BB:GNSS:RTK:BASE<st>:LOCATION:CATALOG` on page 396

`[:SOURCE<hw>] :BB:GNSS:RTK:BASE<st>:LOCATION[:SELECT]` on page 396

Reference Frame

For GNSS receiver, selects the reference frame used to define the receiver coordinates. The transformation between the reference frames is performed automatically.

R&S SMW-K122: For RTK base station, selects the reference frame used to define the receiver or RTK base station coordinates. The transformation between the reference frames is performed automatically.

The following applies:

- $X_{WGS84} = (1 - 0.008 \cdot 10^{-6}) \cdot X_{PZ90} - 0.2041 \cdot 10^{-7} \cdot Y_{PZ90} + 0.1716 \cdot 10^{-7} \cdot Z_{PZ90} - 0.013$
- $Y_{WGS84} = (1 - 0.008 \cdot 10^{-6}) \cdot Y_{PZ90} - 0.2041 \cdot 10^{-7} \cdot X_{PZ90} + 0.1115 \cdot 10^{-7} \cdot Z_{PZ90} + 0.106$
- $Z_{WGS84} = (1 - 0.008 \cdot 10^{-6}) \cdot Z_{PZ90} - 0.1716 \cdot 10^{-7} \cdot X_{PZ90} - 0.1115 \cdot 10^{-7} \cdot Y_{PZ90} + 0.022$

Both reference frames are ECEF frames with a set of associated parameters.

"WGS-84" The World Geodetic System WGS-84 is the reference frame used by GPS.

"PZ 90.11 (GLONASS)" Parametry Zemli PZ (Parameters of the Earth) is the reference frame used by GLONASS.

Remote command:

`[:SOURCE<hw>] :BB:GNSS:RECEIVER [:V<st>] :LOCATION:COORDINATES:RFRAME` on page 383

`[:SOURCE<hw>] :BB:GNSS:RTK:BASE<st>:LOCATION:COORDINATES:RFRAME` on page 396

Location Coordinates, Position Format

In the ECEF coordinate system, a geographic location is identified by three coordinates, the altitude, latitude and longitude. The last two can be displayed in decimal or DMS format. The display format is determined by the parameter "Position Format".

Parameter	Description
"Position Format"	Sets the format in which the Latitude and Longitude are displayed. <ul style="list-style-type: none"> • "DEG:MIN:SEC" The display format is Degree:Minute:Second and Direction, i.e. <code>XX°XX'XX.XX" Direction</code>, where direction can be North/South and East/West. • "Decimal Degrees" The display format is decimal degrees, i.e. <code>+/-XX.XXXXXX°</code>, where "+" indicates North and East and "-" indicates South and West.
"Altitude"	Sets the altitude of the reference location. The altitude value is the height above the ellipsoid (HAE), that is the reference ellipsoid (WGS84 or PZ90).
"Latitude"	Sets the latitude of the reference location.
"Longitude"	Sets the longitude of the reference location.

Altitude, latitude and longitude are configurable, if "Location, Initial Position > User Defined".

Remote command:

`[:SOURce<hw>] :BB:GNSS:RECeiver [:V<st>] :LOCation:COORdinateS:
FORMat` on page 383

`[:SOURce<hw>] :BB:GNSS:RTK:BASE<st>:LOCation:COORdinateS:FORMat`
on page 397

To enter the coordinates in "Position Format > DEG:MIN:SEC"

`[:SOURce<hw>] :BB:GNSS:RECeiver [:V<st>] :LOCation:COORdinateS:DMS:
PZ` on page 384

`[:SOURce<hw>] :BB:GNSS:RECeiver [:V<st>] :LOCation:COORdinateS:
DMS [:WGS]` on page 384

`[:SOURce<hw>] :BB:GNSS:RTK:BASE<st>:LOCation:COORdinateS:DMS:PZ`
on page 398

`[:SOURce<hw>] :BB:GNSS:RTK:BASE<st>:LOCation:COORdinateS:DMS [:
WGS]` on page 398

To enter the coordinates in "Position Format > Decimal Degrees"

`[:SOURce<hw>] :BB:GNSS:RECeiver [:V<st>] :LOCation:COORdinateS:
DECimal:PZ` on page 384

`[:SOURce<hw>] :BB:GNSS:RECeiver [:V<st>] :LOCation:COORdinateS:
DECimal [:WGS]` on page 384

`[:SOURce<hw>] :BB:GNSS:RTK:BASE<st>:LOCation:COORdinateS:DECimal:
PZ` on page 397

`[:SOURce<hw>] :BB:GNSS:RTK:BASE<st>:LOCation:COORdinateS:
DECimal [:WGS]` on page 397

Attitude Behaviour

Sets the attitude characteristics of the receiver.

To define the individual attitude parameters for all attitude behaviors, select "More".
This button is available with option R&S SMW-K108.

- | | |
|------------|--|
| "Constant" | Sets the attitude of the receiver as a combination of the "Yaw / Heading", "Pitch / Elevation", "Roll / Bank" values.
The resulting attitude is a constant value. |
| "Spinning" | Enables a constant rate of change of the roll.
See " Spinning Rate " on page 67. |

"From Waypoint File"/"Align to Motion"

Option: R&S SMW-K108

For "Receiver" > "Position" > "Moving", the attitude parameters are extracted from the selected waypoint file. Further settings are not required.

This extraction forces the attitude parameters to motion direction even if the waypoint has attitude information, like, for example, in a *.xtd file with `<property waypointformat="position_attitude">`.

For specific applications like automotive, it is realistic to set the yaw and pitch to the motion direction of the vehicle. The usual body axes angles of a vehicle point to the direction of the velocity vector.

For other applications, however, like aeronautics with a landing plane, this parameter is not useful. AS an example, the nose of the plane is in an upward direction at the time when the plane is moving downwards.

To visualize the effect, select "Receiver" > "Monitor" > "Attitude View", see ["Display"](#) on page 37.

"From Remote"

Option: R&S SMW-K109

For "Receiver" > "Position" > "Remote Control (HIL)", the attitude parameters are set by the received HIL commands. The selection is suspended.

Remote command:

`[:SOURce<hw>] :BB:GNSS:RECeiver [:V<st>] :ATTitude [:BEHaviour]`
on page 386

System Latency

Option: R&S SMW-K109

System latency is the time period, which the R&S SMW200A needs to receive and process incoming HIL commands.

The minimum value of 20 ms corresponds to the R&S SMW200A hardware processing time. Values higher than 20 ms constitute a delay or a [buffer time](#) to process incoming HIL position data.

The parameter is crucial for [latency calibration](#) between the R&S SMW200A and the control application program.

Remote command:

`[:SOURce<hw>] :BB:GNSS:RECeiver [:V<st>] :HIL:SLATency` on page 335

Interface Type

Option: R&S SMW-K109

Two interface types are provided for the HIL communication between the R&S SMW200A and the control application program, which remotely controls the R&S SMW200A:

"SCPI" A SCPI connection is used for communication. In some case, the Transfer Control Protocol (TCP) can suffer from the overhead caused by the acknowledgments and retransmission. In such cases, enable the socket option "TCP_NODELAY" on the sender side.

"UDP Raw Socket" The R&S SMW200A listens to a unidirectional UDP stream, generated by the control application program.

Remote command:

`[:SOURce<hw>] :BB:GNSS:RECeiver [:V<st>] :HIL:ITYPE` on page 336

UDP Port

Option: R&S SMW-K109

Requires "Interface Type" > "UDP Raw Socket".

Sets the port for incoming UDP packets at the R&S SMW200A.

Remote command:

`[:SOURce<hw>] :BB:GNSS:RECeiver [:V<st>] :HIL:PORT` on page 336

19.3 UDP position data

Compared to the SCPI interface, the User Data Protocol (UDP) offers the following two advantages:

- UDP is known to have less communication overhead, and therefore recommended in time critical simulations.
- The user interface is not blocked (remote state) like when using the SCPI interface. Thus, using UDP you can change the satellite states, power offset and pseudorange bias on-the-fly.

Table 19-2 shows the structure of a UDP data packet containing position data. The position data is provided in a binary format as specified in the [IEEE Standard 754 for Binary Floating-Point Arithmetic](#).



The [measures for proper operation](#) use the SCPI interface and require remote control. After calibration and for retrieving position data via UDP, you have to switch the R&S SMW200A from remote state to manual state.

On the control application, use the command `>L` for this purpose.

Table 19-2: UDP packet and parameter description for HIL position data

Data Type	Size	Parameter	Description	Default unit
integer	4 bytes	reserve0	-	-
integer	4 bytes	reserve1		
integer	4 bytes	reserve2		
integer	4 bytes	reserve3		

Data Type	Size	Parameter	Description	Default unit
double	8 bytes	ElapsedTime	Elapsed time since the simulation start	s
double	8 bytes	<X>	Coordinate in the Earth Fixed Earth Centered (ECEF) coordinate system	m
double	8 bytes	<Y>		
double	8 bytes	<Z>		
double	8 bytes	<XDot>	Velocity vector in ECEF (equivalently <Vx>, <Vy>, <Vz>)	m/s
double	8 bytes	<YDot>		
double	8 bytes	<ZDot>		
double	8 bytes	<XDotDot>	Acceleration vector in ECEF (equivalently <Ax>, <Ay>, <Az>)	m/s ²
double	8 bytes	<YDotDot>		
double	8 bytes	<ZDotDot>		
double	8 bytes	<XDotDotDot>	Jerk vector in ECEF (equivalently <Jx>, <Jy>, <Jz>)	m/s ³
double	8 bytes	<YDotDotDot>		
double	8 bytes	<ZDotDotDot>		
double	8 bytes	<Yaw>	Attitude angles (yaw/heading, pitch/elevation, roll/bank) Unlimited value range to simulate more than one cycle rotation between two updates	rad
double	8 bytes	<Pitch>		
double	8 bytes	<Roll>		
double	8 bytes	<YDot>	Attitude angular rate of change	rad/s
double	8 bytes	<PDot>		
double	8 bytes	<RDot>		
double	8 bytes	<YDotDot>	Attitude angular second order derivative	rad/s ²
double	8 bytes	<PDotDot>		
double	8 bytes	<RDotDot>		
double	8 bytes	<YDotDotDot>	Attitude angular third order derivative	rad/s ³
double	8 bytes	<PDotDotDot>		
double	8 bytes	<RDotDotDot>		

19.4 SCPI position data

During remote operation, the control application program sends real-time HIL (SCPI) commands to the R&S SMW200A. The HIL commands are sent with low and varying time resolution. This time resolution is also referred as a **HIL update rate**. It is typically a value from 10 Hz to 100 Hz (or 10 ms and 100 ms) and depends on the motion simulator, in particular on its real-time capabilities.

HIL position data is provided by two commands:

```
[ :SOURCE<hw> ] :BB:GNSS:RT:RECEIVER[:V<st>] :HILPosition:MODE:A
```

```
[ :SOURCE<hw> ] :BB:GNSS:RT:RECEIVER[:V<st>] :HILPosition:MODE:B
```

The command defines the HIL position, motion (velocity, acceleration, jerk) and attitude at a specific moment of time. The position is defined by earth centered earth fixed

(ECEF) coordinates for mode A and by north east down (NED) coordinates for mode B. The moment of time is given as a time offset (`<ElapsedTime>`) from the simulation time start.

19.5 Remote-control commands

Option: R&S SMW-K109

Understanding the response of the query `SOURCE:BB:GNSS:RT:RECEIVER1:HIL-POSITION:LATENCY:STATISTICS?`

The following are three examples that illustrate how the HIL update rate and the buffer time influence the way the received HIL commands are processed.

The query is sent each 5 s as indicated by the difference between two subsequently `<CmdHwTime>` values.

The response of each individual query is a string. The set of strings per example have been converted to a `*.CSV` file and formatted for better understanding.

Example: Non-real-time (RT) processor, HIL update rate = 100 Hz, $t_{\text{Delay}} = 0.02$ s

<code><CmdHwTime></code>	<code><LastLatency></code>	<code><MaxLatency></code>	<code><MinLatency></code>	<code><NoZeroValues></code>	<code><CmdReceived></code>	<code><CmdUsed></code>	<code><CmdSync></code>	<code><CmdExterp></code>	<code><Interp></code>	<code><Predictions></code>	<code><MaxUsed></code>	<code><MinUsed></code>
254.07	0	0.04	0	26	500	492	474	18	0	8	2	0
259.07	0	0.05	0	15	500	491	485	6	0	9	2	0
264.07	0	0.04	0	23	500	491	477	14	0	9	2	0
269.07	0	0.04	0	14	500	492	486	6	0	8	3	0
274.07	0	0.04	0	38	500	488	462	26	0	12	2	0
279.07	0	0.04	0	18	500	493	482	11	0	7	2	0
284.07	0	0.04	0	47	500	484	453	31	0	16	2	0

Figure 19-2: Example of latency statistics

- 1 = Varying latency of up to 50 ms
- 2 = Number of non-zero latency values varies
- 3 = Number of commands received during each period = 500
- 4 = Not all received commands are used (`<CmdUsed>` < `<CmdReceived>`)
- 5 = Not all commands are applied at their specified time (`<CmdSync>` < `<CmdUsed>`)
- 6 = Interpolation not applied; commands do not arrive in advance
- 7 = Number of times the prediction algorithm was applied

Example: Non-real-time (RT) processor, HIL update rate = 100 Hz, $t_{Delay} = 0.15$ s

This example illustrates that the increased t_{Delay} improves the number of processed HIL commands. The system latency however also increases.

<CmdHwTime>	<LastLatency>	<MaxLatency>	<MinLatency>	<NoZeroValues>	<CmdReceived>	1 <CmdUsed>	<CmdSync>	<CmdExterp>	2 <Interp>	<Predictions>	3 <MaxUsed>	<MinUsed>
253.94	0	0.04	0	45	500	500	500	0	0	0	14	9
258.94	0	0.05	0	45	500	500	500	0	0	0	14	8
263.94	0	0.04	0	46	500	500	500	0	0	0	14	9
268.94	0	0.05	0	50	500	500	500	0	0	0	14	8
273.94	0	0.04	0	76	500	500	500	0	0	0	14	9
278.94	0	0.05	0	30	500	500	500	0	0	0	14	8

Figure 19-3: Impact of the increased t_{Delay}

- 1 = All commands are used synchronous
- 2 = Interpolation or prediction is not necessary and not applied
- 3 = Increased number of buffered commands; the values indicate that there is a room to decrease (optimize) the t_{Delay} (see Chapter 19.1.4, "Adding a constant delay to compensate for command jitter", on page 318)

Example: Non-real-time (RT) processor, HIL update rate = 10 Hz, $t_{Delay} = 0.15$ s

This example illustrates that varying the HIL update rate while keeping the same t_{Delay} also improves the HIL command processing. The generated signal is continuous. The system latency however also increases.

<CmdHwTime>	<LastLatency>	<MaxLatency>	<MinLatency>	<NoZeroValues>	<CmdReceived>	1 <CmdUsed>	<CmdSync>	<CmdExterp>	2 <Interp>	<Predictions>	<MaxUsed>	<MinUsed>
98.85	0	0.03	0	2	50	50	50	0	450	0	2	1
103.85	0	0.02	0	2	50	50	50	0	450	0	2	1
108.85	0	0.03	0	2	50	50	50	0	450	0	2	1
113.85	0	0.03	0	1	50	50	50	0	450	0	2	1
118.85	0	0.04	0	2	50	50	50	0	450	0	2	0
123.85	0	0.02	0	3	50	50	50	0	450	0	2	1

Figure 19-4: Impact of the reduced HIL update rate

- 1 = All commands are used synchronous
- 2 = Interpolation is required and applied (ideal situation where each HIL command is executed synchronous and there are enough HIL commands to interpolate the values from)

The last two examples show approaches that are suitable if your system tolerates system delays.

Commands:

- [:SOURce<hw>]:BB:GNSS:RT:RECeiver[:V<st>]:HILPosition:MODE:A.....331
- [:SOURce<hw>]:BB:GNSS:RT:RECeiver[:V<st>]:HILPosition:MODE:B.....332
- [:SOURce<hw>]:BB:GNSS:RT:RECeiver[:V<st>]:HILPosition:LATency?..... 333
- [:SOURce<hw>]:BB:GNSS:RT:RECeiver[:V<st>]:HILPosition:LATency:STATistics?.....333
- [:SOURce<hw>]:BB:GNSS:RECeiver[:V<st>]:HIL:SLATency..... 335
- [:SOURce<hw>]:BB:GNSS:RECeiver[:V<st>]:HIL:ITYPE.....336
- [:SOURce<hw>]:BB:GNSS:RECeiver[:V<st>]:HIL:PORT.....336
- [:SOURce<hw>]:BB:GNSS:RT:HWTTime?.....336

[:SOURce<hw>]:BB:GNSS:RT:RECEiver[:V<st>]:HILPosition:MODE:A
 <ElapsedTime>, <X>, <Y>, <Z>, <XDot>, <YDot>, <ZDot>, <XDotDot>, <YDotDot>, <ZDotDot>, <XDotDotDot>, <YDotDotDot>, <ZDotDotDot>, <Yaw>, <Pitch>, <Roll>, <YawDot>, <PitchDot>, <RollDot>, <YawDotDot>, <PitchDotDot>, <RollDotDot>, <YawDotDotDot>, <PitchDotDotDot>, <RollDotDotDot>

Sets hardware in loop (HIL) position, motion (velocity, acceleration, jerk) and attitude in Earth Fixed Earth Centered ECEF coordinates.

The yaw/heading, pitch/elevation, roll/bank rotation angles and their derivatives are obtained by rotating the body (XYZ) frame. The frame is rotated starting from an aligned state with the local NED frame. Three consecutive Euler rotations are: around the z axis, the y axis and the x axis.

Table 19-3: SCPI parameter description

Parameter		Description	Default unit
<X>, <Y>, <Z>	Mandatory	Coordinate in the Earth Fixed Earth Centered (ECEF) coordinate system	m
<XDot>, <YDot>, <ZDot>	Mandatory	Velocity vector in ECEF (equivalently V_x , V_y , V_z)	m/s
<XDotDot>, <YDotDot>, <ZDotDot>	Mandatory	Acceleration vector in ECEF (equivalently A_x , A_y , A_z)	m/s ²
<XDotDotDot>, <YDotDotDot>, <ZDotDotDot>	Mandatory	Jerk vector in ECEF (equivalently J_x , J_y , J_z)	m/s ³
[<Yaw>, <Pitch>, <Roll>]	Optional	Attitude angles (yaw/heading, pitch/elevation, roll/bank) Unlimited value range to simulate more than one cycle rotation between two updates	rad
[<YDot>, <PDot>, <RDot>]	Optional	Attitude angular rate of change	rad/s
[<YDotDot>, <PDotDot>, <RDotDot>]	Optional	Attitude angular second order derivative	rad/s ²
[<YDotDotDot>, <PDotDotDot>, <RDotDotDot>]	Optional	Attitude angular third order derivative	rad/s ³

See also [Chapter 19.1.3, "Latency calibration"](#), on page 316.

For HIL mode A, position data can also be retrieved via UDP packets, see [Chapter 19.3, "UDP position data"](#), on page 327.

Parameters:

<ElapsedTime> float
 Elapsed time from the simulation start, as queried with the command `[:SOURce<hw>]:BB:GNSS:RT:HWTTime?`.
 For description of the other parameters, see [Table 19-3](#).
 Range: 0 to 99999999

Usage: Setting only

[:SOURCE<hw>]:BB:GNSS:RT:RECeiver[:V<st>]:HILPosition:MODE:B
 <ElapsedTime>, <Latitude>, <Longitude>, <Altitude>, <NDot>, <EDot>, <DDot>,
 <NDotDot>, <EDotDot>, <DDotDot>, <NDotDotDot>, <EDotDotDot>,
 <DDotDotDot>, <Yaw>, <Pitch>, <Roll>, <YawDot>, <PitchDot>, <RollDot>,
 <YawDotDot>, <PitchDotDot>, <RollDotDot>, <YawDotDotDot>,
 <PitchDotDotDot>, <RollDotDotDot>

Sets hardware in loop (HIL) position, motion (velocity, acceleration, jerk) and attitude in North East Down (NED) coordinates.

The yaw/heading, pitch/elevation, roll/bank rotation angles and their derivatives are obtained by rotating the body (XYZ) frame. The frame is rotated starting from an aligned state with the local NED frame. Three consecutive Euler rotations are: around the z axis, the y axis and the x axis.

Table 19-4: Parameter description

Parameter		Description	Default unit
<Latitude>, <Longitude>, <Altitude>	Mandatory	Geodetic location	°
<NDot>,<EDot>, <DDot>	Mandatory	Velocity vector in the North East Down (NED) coordinate system (equivalently v_n , v_e , v_d)	m/s
<NDotDot>, <EDotDot>, <DDotDot>	Mandatory	Acceleration vector in NED (equivalently a_n , a_e , a_d)	m/s ²
<NDotDotDot>, <EDotDotDot>, <DDotDotDot>	Mandatory	Jerk vector in NED (equivalently j_n , j_e , j_d)	m/s ³
[<Yaw>,<Pitch>, <Roll>]	Optional	Attitude angles (yaw/heading, pitch/elevation, roll/bank) Unlimited value range to simulate more than one cycle rotation between two updates	rad
[<YDot>,<PDot>, <RDot>]	Optional	Attitude angular rate of change	rad/s
[<YDotDot>, <PDotDot>, <RDotDot>]	Optional	Attitude angular second order derivative	rad/s ²
[<YDotDotDot>, <PDotDotDot>, <RDotDotDot>]	Optional	Attitude angular third order derivative	rad/s ³

See also [Chapter 19.1.3, "Latency calibration"](#), on page 316.

This mode is currently supported for position data retrieved via SCPI commands only. For HIL mode A, position data can also be retrieved via UDP packets, see [Chapter 19.3, "UDP position data"](#), on page 327.

Parameters:

<ElapsedTime> float
 Elapsed time from the simulation start, as queried with the command `[:SOURce<hw>] :BB:GNSS:RT:HWTTime?`.
 For description of the other parameters, see [Table 19-4](#).
 Range: 0 to 999999999

Usage: Setting only

[:SOURce<hw>] :BB:GNSS:RT:RECEiver[:V<st>] :HILPosition:LATency?

Queries the predicted latency that is the time delay between the elapsed time of HiL mode command and the time to execute this command in the R&S SMW200A. HiL command refers to HiL mode A or HiL mode B commands:

`[:SOURce<hw>] :BB:GNSS:RT:RECEiver[:V<st>] :HILPosition:MODE:A`

`[:SOURce<hw>] :BB:GNSS:RT:RECEiver[:V<st>] :HILPosition:MODE:B`

How to: [Chapter 19.1.3, "Latency calibration"](#), on page 316

Return values:

<Latency> float
 Range: min to max
 Increment: 0.001
 *RST: 0
 Default unit: s

Usage: Query only

[:SOURce<hw>] :BB:GNSS:RT:RECEiver[:V<st>] :HILPosition:LATency:STATistics?

Queries the current latency $t_{\text{cal.latency},i}$ and statistics on the latency values.

This command returns also the minimum deviation and the maximum deviation from zero latency. Also, it returns the measured number of non-zero latency values since the last query with this command.

The following terms are used:

- HiL command refers to HiL mode A or HiL mode B commands:
`[:SOURce<hw>] :BB:GNSS:RT:RECEiver[:V<st>] :HILPosition:MODE:A`
`[:SOURce<hw>] :BB:GNSS:RT:RECEiver[:V<st>] :HILPosition:MODE:B`
- Dropped commands are commands that are evaluated, buffered but not applied because they become outdated as more up-to-date information is received
- Return values apply for the period since the last query with this command.

How to: [Chapter 19.1.3, "Latency calibration"](#), on page 316

Return values:

<CmdHwTime>	float	The hardware time at the moment the last HIL command is received. Increment: 0.001 *RST: 0
<LastLatency>	float	Time delay between the time specified with the parameter <ElapsedTime> in a HIL command and the time this command is executed in the R&S SMW200A. Increment: 0.001 *RST: 0 Default unit: s
<MaxLatency>	float	The largest latency value since the last time this query was sent. Increment: 0.001 *RST: 0 Default unit: s
<MinLatency>	float	The smallest latency value since the last time this query was sent. Increment: 0.001 *RST: 0 Default unit: s
<NoZeroValues>	integer	Number of non-zero latency values since the last time this query was sent. *RST: 0
<CmdReceived>	integer	Accumulated <LastLatency> values since the last time this query was sent. *RST: 0
<CmdUsed>	integer	The number of used HIL commands, excluding the dropped HIL commands, since the last time this query was sent. *RST: 0
<CmdSync>	integer	The number of HIL commands applied at their specified time *RST: 0

<CmdExterp>	integer	The number of extrapolated HIL commands. The commands are applied later than their specified time. *RST: 0
<CmdInterp>	integer	The number of internal position updates. The value includes commands describing both situations, moment of time in past and moment of time in the future. *RST: 0
<CmdPredict>	integer	The number of internal position updates performed by the prediction algorithm, see Chapter 19.1.6, "Trajectory prediction" , on page 320. *RST: 0
<MaxUsed>	integer	The maximum number buffered commands *RST: 0
<MinUsed>	integer	The minimum number buffered commands *RST: 0
Example:		See " Understanding the response of the query SOURce:BB:GNSS:RT:RECeiver1:HILPosition:LATency:STATistics? " on page 329.
Usage:		Query only

[:SOURce<hw>]:BB:GNSS:RECeiver[:V<st>]:HIL:SLATency <SystemLatency>

Sets the time delay between the time specified with the parameter <ElapsedTime> in the HIL [mode A](#) position data command and the time this command is executed in the R&S SMW200A.

See also [Chapter 19.1.2, "System latency"](#), on page 316.

You can use the retrieved value for latency calibration, see [Chapter 19.1.3, "Latency calibration"](#), on page 316.

Parameters:

<SystemLatency>	float
Range:	0.02 to 0.15
Increment:	0.001
*RST:	0.02
Default unit:	s

Example: See "[Understanding the response of the query SOURce:BB:GNSS:RT:RECeiver1:HILPosition:LATency:STATistics?](#)" on page 329.

Manual operation: See "[System Latency](#)" on page 326

[:SOURce<hw>]:BB:GNSS:RECeiver[:V<st>]:HIL:ITYPE <InterfaceType>

Set the interface type for the remote communication between R&S SMW200A and the control application.

Parameters:

<InterfaceType> SCPI | UDP
 *RST: SCPI

Example: SOURce1:BB:GNSS:RECeiver:V1:HIL:ITYPE UDP

Manual operation: See "[Interface Type](#)" on page 326

[:SOURce<hw>]:BB:GNSS:RECeiver[:V<st>]:HIL:PORT <UdpPort>

Set the UDP port number at the R&S SMW200A for the HIL interface.

Parameters:

<UdpPort> integer
 Range: 0 to 65535
 *RST: 7755

Example: SOURce1:BB:GNSS:RECeiver:V1:HIL:PORT 7756

Manual operation: See "[UDP Port](#)" on page 327

[:SOURce<hw>]:BB:GNSS:RT:HWTIME?

Queries the time elapsed since the simulation start.

To query the simulation start time, use the command:

[\[:SOURce<hw>\]:BB:GNSS:TIME:START:TIME.](#)

Return values:

<ElapsedTime> float
 Range: 0 to max
 Increment: 0.001
 *RST: 0
 Default unit: s

Example: See [\[:SOURce<hw>\]:BB:GNSS:RT:RECeiver\[:V<st>\]:HILPosition:MODE:A](#) on page 331.

Usage: Query only

20 Signal generation control

This section lists settings provided for defining the signal generation start and for generating signals necessary for synchronization with other instruments.

Settings:

- [Trigger settings](#)..... 337
- [Marker settings](#)..... 342
- [Clock settings](#)..... 346
- [Local and global connectors settings](#)..... 347

20.1 Trigger settings

Access:

- ▶ Select "GNSS" > "Trigger In".

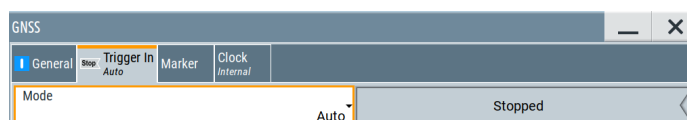

This tab provides settings to select and configure the trigger, like trigger source, trigger mode and trigger delays, and to arm or trigger an internal trigger manually. The header of the tab displays the status of the trigger signal and trigger mode. As in the tabs "Marker" and "Clock", this tab provides also access to the settings of the related connectors.

To trigger on a single event

1. Set "Mode" > "Single".
2. Set "Source" > "Internal".
3. Set the "Signal Duration", to specify how long the R&S SMW200A generates the signal after the trigger event.
4. Select "General" > "State" > "On".
5. If no trigger event occurs, press "Execute Trigger" to execute the trigger manually.

Routing and activating a trigger signal

1. Define the effect of a trigger event and the trigger signal source.
 - a) Select "Trigger In" > "Mode".
 - b) Select "Trigger In" > "Source".
2. For external trigger signals, define the connector for signal input. See [Chapter 20.4, "Local and global connectors settings"](#), on page 347.

You can map trigger signals to one or more USER x or T/M connectors.

Local and global connectors settings allow you to configure the signal mapping, the polarity, the trigger threshold and the input impedance of the input connectors.

3. Activate baseband signal generation. In the block diagram, set "Baseband" > "On".
The R&S SMW200A starts baseband signal generation after the configured trigger event.

About baseband trigger signals

This section focuses on the available settings.

For detailed information on baseband trigger signals, see section "About trigger signals" in the R&S SMW200A user manual.

Settings:

Trigger Settings Common to All Basebands.....	338
Mode.....	338
Signal Duration.....	339
Running/Stopped.....	339
Time Based Trigger.....	339
Trigger Time.....	340
Arm.....	340
Execute Trigger.....	340
Source.....	340
Sync. Output to External Trigger/Sync. Output to Trigger.....	341
External Inhibit/Trigger Inhibit.....	342
External Delay/Trigger Delay.....	342

Trigger Settings Common to All Basebands

To enable simultaneous signal generation in all basebands, the R&S SMW200A couples the trigger settings in the available basebands in any instrument's configuration involving signal routing with signal addition. For example, in MIMO configuration, routing and summing of basebands or of streams.

The icon  indicates that common trigger settings are applied.

You can access and configure the common trigger source and trigger mode settings in any of the basebands. An arm or a restart trigger event applies to all basebands, too. You can still apply different delay to each of the triggers individually.

Mode

Selects the trigger mode. The mode determines the effect of a trigger event on the signal generation.

For more information, see chapter "About trigger signals" in the R&S SMW200A user manual.

- "Auto"
The signal is generated continuously.
- "Retrigger"

The signal is generated continuously. A trigger event (internal or external) causes a restart.

- "Armed Auto"
The signal is generated only when a trigger event occurs. Then the signal is generated continuously.
An "Arm" stops the signal generation. A subsequent trigger event (internal or external) causes a restart.
- "Armed Retrigger"
The signal is generated only when a trigger event occurs. Then the signal is generated continuously. Every subsequent trigger event causes a restart.
An "Arm" stops signal generation. A subsequent trigger event (internal or external) causes a restart.
- "Single"
The signal is generated only when a trigger event occurs. Then the signal is generated once to the length specified at "Signal Duration".
Every subsequent trigger event (internal or external) causes a restart.

Remote command:

[\[:SOURce<hw>\]:BB:GNSS\[:TRIGger\]:SEQuence](#) on page 640

Signal Duration

Requires trigger "Mode" > "Single".

Enters the length of the trigger signal sequence.

Use this parameter, for example, for the following applications:

- To output the trigger signal partly.
- To output a predefined sequence of the trigger signal.

Remote command:

[\[:SOURce<hw>\]:BB:GNSS:TRIGger:SLENgth](#) on page 643

Running/Stopped

With enabled modulation, displays the status of signal generation for all trigger modes.

- "Running"
The signal is generated; a trigger was (internally or externally) initiated in triggered mode.
- "Stopped"
The signal is not generated and the instrument waits for a trigger event.

Remote command:

[\[:SOURce<hw>\]:BB:GNSS:TRIGger:RMODe?](#) on page 641

Time Based Trigger

Requires trigger "Mode" > "Armed Auto"/"Single".

Activates time-based triggering with a fixed time reference.

The R&S SMW200A triggers signal generation when its operating system time ("Current Time") matches a specified time trigger ("Trigger Time"). As trigger source, you can use an internal trigger or an external global trigger.

How to: Chapter "Time-based triggering" in the R&S SMW200A user manual.

Remote command:

[\[:SOURce<hw>\]:BB:GNSS:TRIGger:TIME\[:STATe\]](#) on page 642

Trigger Time

Requires trigger "Mode" > "Armed Auto"/"Single".

Sets date and time for a time-based trigger signal.

Set a trigger time that is later than the "Current Time". The current time is the operating system time of the R&S SMW200A. If you set an earlier trigger time than the current time, time-based triggering is not possible.

How to: Chapter "Time-based triggering" in the R&S SMW200A user manual.

"Date" Sets the date of the time-based trigger in format YYYY-MM-DD.

Remote command:

[\[:SOURCE<hw>\]:BB:GNSS:TRIGger:TIME:DATE](#) on page 641

"Time" Sets the time of the time-based trigger in format hh:mm:ss.

Remote command:

[\[:SOURCE<hw>\]:BB:GNSS:TRIGger:TIME:TIME](#) on page 642

Arm

Stops the signal generation until subsequent trigger event occurs.

Remote command:

[\[:SOURCE<hw>\]:BB:GNSS:TRIGger:ARM:EXECute](#) on page 643

Execute Trigger

For internal trigger source, executes trigger manually.

Remote command:

[\[:SOURCE<hw>\]:BB:GNSS:TRIGger:EXECute](#) on page 643

Source

The following sources of the trigger signal are available:

- "Internal"
The trigger event is internal. Tap "Execute Trigger" to trigger signal generation manually.
- "Internal (Baseband A/B)"
The trigger event is provided by the trigger signal from the other basebands. If common trigger settings are applied, this trigger source is disabled.
- "External Global Trigger"
The trigger event is the active edge of an external trigger signal provided and configured at the USER x connectors.
- "External Local Trigger"
The trigger event is the active edge of an external trigger signal provided and configured at the local T/M/C connector.
With coupled trigger settings, the signal has to be provided at the T/M/C1/2/3 connectors.
- "External Local Clock"
The trigger event is the active edge of an external local clock signal provided and configured at the local T/M/C connector.
With coupled trigger settings, the signal has to be provided at the T/M/C1 connector.
- "Baseband Sync In"

Requires "Multi Instrument Trigger" > "Secondary" for primary-secondary instrument mode.

Triggers signal generation at the secondary instrument by the active edge of the baseband synchronization signal of the primary instrument.

How to: "[Routing and activating a trigger signal](#)" on page 337

Remote command:

`[:SOURce<hw>] :BB:GNSS:TRIGger:SOURce` on page 640

Sync. Output to External Trigger/Sync. Output to Trigger

Enables signal output synchronous to the trigger event.

- "On"

Corresponds to the default state of this parameter.

The signal calculation starts simultaneously with the trigger event. Because of the processing time of the instrument, the first samples are cut off and no signal is output. After elapsing of the internal processing time, the output signal is synchronous to the trigger event.

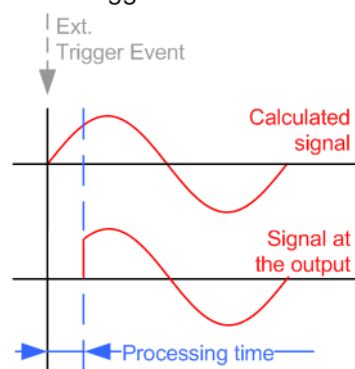

- "Off"

The signal output begins after elapsing of the processing time. Signal output starts with sample 0. The complete signal is output.

This mode is recommended for triggering of short signal sequences. Short sequences are sequences with signal duration comparable with the processing time of the instrument.

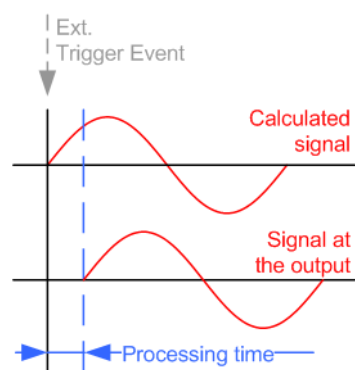

Remote command:

`[:SOURce<hw>] :BB:GNSS:TRIGger:EXTernal:SYNChronize:OUTPut` on page 643

External Inhibit/Trigger Inhibit

Applies for an external trigger signal or trigger signal from the other path.

Sets the duration with that any following trigger event is suppressed. In "Retrigger" mode, for example, a new trigger event does not cause a restart of the signal generation until the specified inhibit duration does not expire.

For more information, see chapter "Basics on signals, modulation formats and filters" in the user manual.

Remote command:

[\[:SOURCE<hw>\]:BB:GNSS:TRIGGER\[:EXTERNAL\]:INHIBIT](#) on page 645

[\[:SOURCE<hw>\]:BB:GNSS:TRIGGER:OBASBAND:INHIBIT](#) on page 644

External Delay/Trigger Delay

Delays the trigger event of the signal from:

- The external trigger source
- The other path
- The other basebands (internal trigger), if common trigger settings are used.

Use this setting to:

- Synchronize the instrument with the device under test (DUT) or other external devices
- Postpone the signal generation start in the basebands compared to each other

For more information, see chapter "Basics on ..." in the R&S SMW200A user manual.

Remote command:

[\[:SOURCE<hw>\]:BB:GNSS:TRIGGER\[:EXTERNAL\]:DELAY](#) on page 644

[\[:SOURCE<hw>\]:BB:GNSS:TRIGGER:OBASBAND:DELAY](#) on page 644

20.2 Marker settings

Access:

1. Select "GNSS" > "Marker".

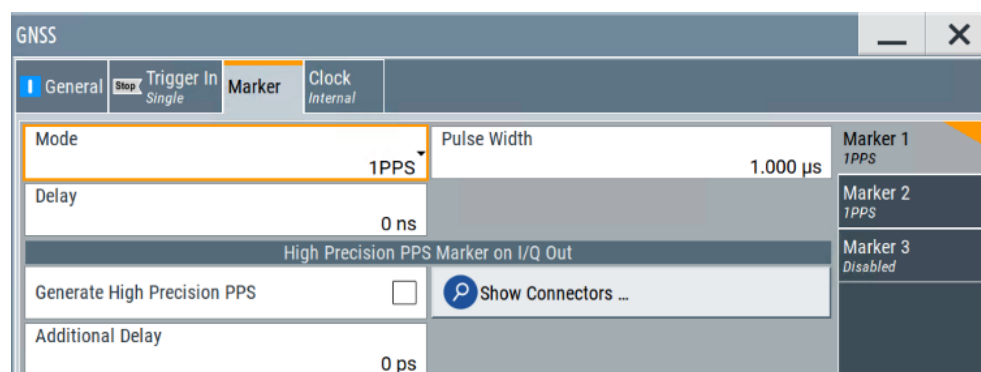

This tab provides settings to select and configure the marker output signal including marker mode and marker delay.

By default, the settings for "Marker 1" are displayed. The set "Marker Mode" is also displayed for each marker on the "Marker x" side tabs.

- To configure another marker, select e.g. the "Marker 2" side tab.

Maximum two markers can be mapped in the GNSS firmware. "Marker 3" is not available. This marker operates in "Mode" > "Disabled" and is suspended.

To derive the frequency of a pulse marker signal

- Select marker "Mode" > "Pattern" and set "Pattern" = "10".
- Route the marker signal to one of the "User x" output connectors, e.g. for "User 1".
 - Select "Marker" > "Global Connectors" > "Routing".
 - Set "Direction" > "Output".
 - Set "Signal" > "Baseband A Marker 1".

With a fixed symbol rate of 1.023 Msym/s, the frequency of the marker signal measured at the "User x" output connector is 511.5 kHz.

The same value results from the setting "Mode" > "Pulse" and "Divider" > "2".

Mode	Pulse	Divider	2
		Frequency	511.500 0kHz

To generate a high-precision marker PPS signal

Requires R&S SMW-B9.

The procedure illustrates how to generate and output a high-precision marker signal associated with "Marker 1". The signal is useful, e.g., for time alignment in hardware in the loop (HIL) test setups.

The high-precision marker signal can only be generated for path A of the R&S SMW200A.

- Specify the following:
 - Select between marker modes "1PPS", "1PP2S" or "10PPS".
 - Define the pulse width.
 - Set the marker delay.
- Optionally, specify an additional delay for fine-tuning the marker alignment to the output RF signal.
- To monitor the output connectors that output the high-precision PPS marker signal, click "Show Connector".

The dialog displays the physical location of the associated connectors on the rear panel of the instrument.

- Select "Generate High Precision PPS > On".

The high-precision PPS marker signal is output at the analog I/Q connectors "I" and "Q" on the rear panel of the instrument.

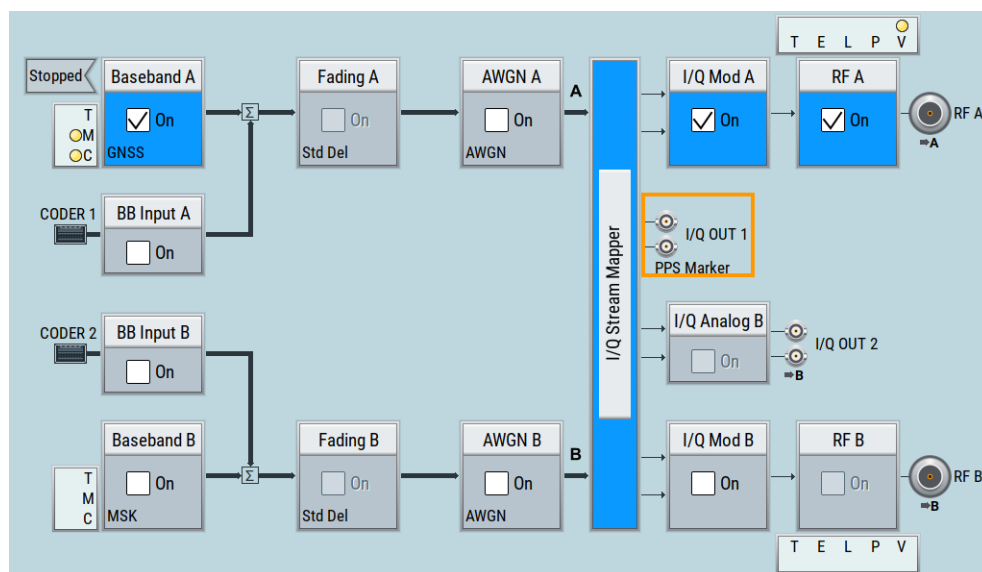

Routing and activating a marker signal

1. To define the signal shape of an individual marker signal "x", select "Marker" > "Marker x" > "Mode".
2. Optionally, define the connector for signal output. See [Chapter 20.4, "Local and global connectors settings"](#), on page 347.
You can map marker signals to one or more USER x or T/M connectors.
3. Enable baseband signal generation. In the block diagram, set "Baseband" > "On".
The R&S SMW200A adds the marker signal to the baseband signal. Also, R&S SMW200A outputs this signal at the configured USER x connector.

About marker output signals

This section focuses on the available settings.

For detailed information on baseband trigger signals, see section About trigger signals" in the R&S SMW200A user manual.

Settings:

Mode.....	344
Delay.....	345
High Precision PPS Marker on I/Q Out.....	346
L Generate High Precision PPS.....	346
L Additional Delay.....	346
L Show Connector.....	346

Mode

Sets the marker mode that defines the shape and periodicity of the marker signals.
You can configure marker modes for up to 3 markers. The marker configuration changes with the selected marker mode.

How to: ["Routing and activating a marker signal"](#) on page 344

"1PPS"/"10PPS"/"1PP2S"

A marker signal is generated at:

- The start of every second
- 10 times per second or once every 100 ms
- Once every two seconds

Set the "Pulse Width" in the corresponding field.

Remote command:

`[:SOURce<hw>] :BB:GNSS:TRIGger:OUTPut<ch>:PULSe:WIDTh` on page 648

"Pulse"

Regular marker signal.

To define the pulse frequency, set the divider. The pulse frequency is derived by dividing the chip rate by the divider; the resulting "Frequency" value is displayed.

Mode	Pulse	Divider	2
		Frequency	511.500 0kHz

Remote command:

`[:SOURce<hw>] :BB:GNSS:TRIGger:OUTPut<ch>:PULSe:DIVider` on page 647

`[:SOURce<hw>] :BB:GNSS:TRIGger:OUTPut<ch>:PULSe:FREQuency?` on page 648

"Pattern"

Marker signal that is defined by a bit pattern. The pattern has a maximum length of 64 bits.

Remote command:

`[:SOURce<hw>] :BB:GNSS:TRIGger:OUTPut<ch>:PATTern` on page 647

"On/Off Ratio"

Regular marker signal that is defined as on-time and off-time; a period lasts one on and off cycle.

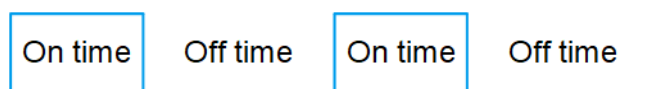

Remote command:

`[:SOURce<hw>] :BB:GNSS:TRIGger:OUTPut<ch>:ONTIME` on page 646

`[:SOURce<hw>] :BB:GNSS:TRIGger:OUTPut<ch>:OFFTIME` on page 646

Remote command:

`[:SOURce<hw>] :BB:GNSS:TRIGger:OUTPut<ch>:MODE` on page 646

Delay

Delays the marker signal at the marker output relative to the signal generation start.

Variation of the parameter "Marker x" > "Delay" causes signal recalculation.

Remote command:

[:SOURce<hw>] :BB:GNSS:TRIGger:OUTPut<ch>:DELaY on page 646

High Precision PPS Marker on I/Q Out

Requires R&S SMW-B9.

The panel comprises settings to configure high-precision marker signals output at the analog I/Q output connectors "I"/"Q".

Generate High Precision PPS ← High Precision PPS Marker on I/Q Out

Enables generation of a high-precision PPS marker signal.

Remote command:

[:SOURce<hw>] :BB:GNSS:TRIGger:OUTPut<ch>:HPPS:STATe on page 647

Additional Delay ← High Precision PPS Marker on I/Q Out

Sets an additional delay for the high-precision PPS marker signal.

Remote command:

[:SOURce<hw>] :BB:GNSS:TRIGger:OUTPut<ch>:HPPS:ADELaY on page 647



Show Connector ← High Precision PPS Marker on I/Q Out

Accesses a dialog that displays the physical location of the selected connector on the front/rear panel of the instrument.

20.3 Clock settings

Access:

- ▶ Select "GNSS" > "Clock".

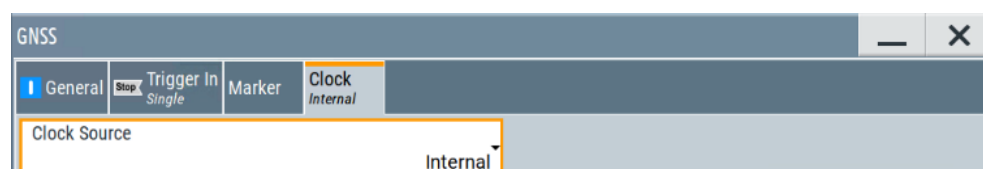

This tab provides settings to select and configure the clock signal, like the clock source and clock mode.

Defining the clock

1. Select "Clock" > "Source" to define the source of the clock signal.
2. For external clock signals, define the connector for the signal input. See [Chapter 20.4, "Local and global connectors settings"](#), on page 347.
You can map clock signals to one or more USER x or T/M connectors.
Local and global connectors settings allow you to configure the signal mapping, the polarity, the trigger threshold and the input impedance of the input connectors.
3. Activate baseband signal generation. In the block diagram, set "Baseband" > "On".

The R&S SMW200A starts baseband signal generation with a symbol rate that equals the clock rate.

About clock signals

This section focuses on the available settings.

For detailed information on baseband trigger signals, see section "About trigger signals" in the R&S SMW200A user manual.

Settings:

Clock Source	347
Clock Mode	347
Measured External Clock	347

Clock Source

Selects the clock source.

- "Internal"
The instrument uses its internal clock reference.
- "External Local Clock"
Option: R&S SMW-B10
The instrument expects an external clock reference at the local T/M/C connector.

How to: "[Defining the clock](#)" on page 346

Remote command:

`[:SOURce<hw>] :BB:GNSS:CLOCK:SOURce` on page 649

Clock Mode

Sets the type of externally supplied clock.

Remote command:

`[:SOURce<hw>] :BB:GNSS:CLOCK:MODE` on page 649

Measured External Clock

Provided for permanent monitoring of the enabled and externally supplied clock signal.

Remote command:

`CLOCK:INPut:FREQuency?`

20.4 Local and global connectors settings

Opens a dialog to configure local connectors or global connectors.

The button is available in the following dialogs or tabs:

- "Trigger / Marker / Clock" dialog that is accessible via the "TMC" block in the block diagram.
- "Trigger In", "Marker" and "Clock" tabs of baseband signal configuration dialogs that you can open via the "Baseband" block in the block diagram. These tabs are available, for example, for "ARB" baseband signals.



See also chapter "Local and global connectors settings" in the user manual.

21 Signal generation tasks with the GNSS options

- [General workflow for signal generation tasks](#)..... 349
- [Generating GNSS signals for simple receiver tests](#)..... 351
- [Simulating real-world effects](#)..... 351
- [Adding noise or CW interferer](#)..... 351
- [Loading historical data](#)..... 351
- [Generating GNSS advanced mode signals](#)..... 351

21.1 General workflow for signal generation tasks



The workflow examples provided in this section assume an R&S SMW200A, fully equipped with all available GNSS options.

The general workflow shows the main configuration steps to be performed for almost all configuration tasks. Therefore, the examples generally refer to the workflow. Additional steps and settings are described in the examples explicitly.

The flow diagram in [Figure 21-1](#) shows an overview of the configuration steps, that are common for most of the configurations tasks.

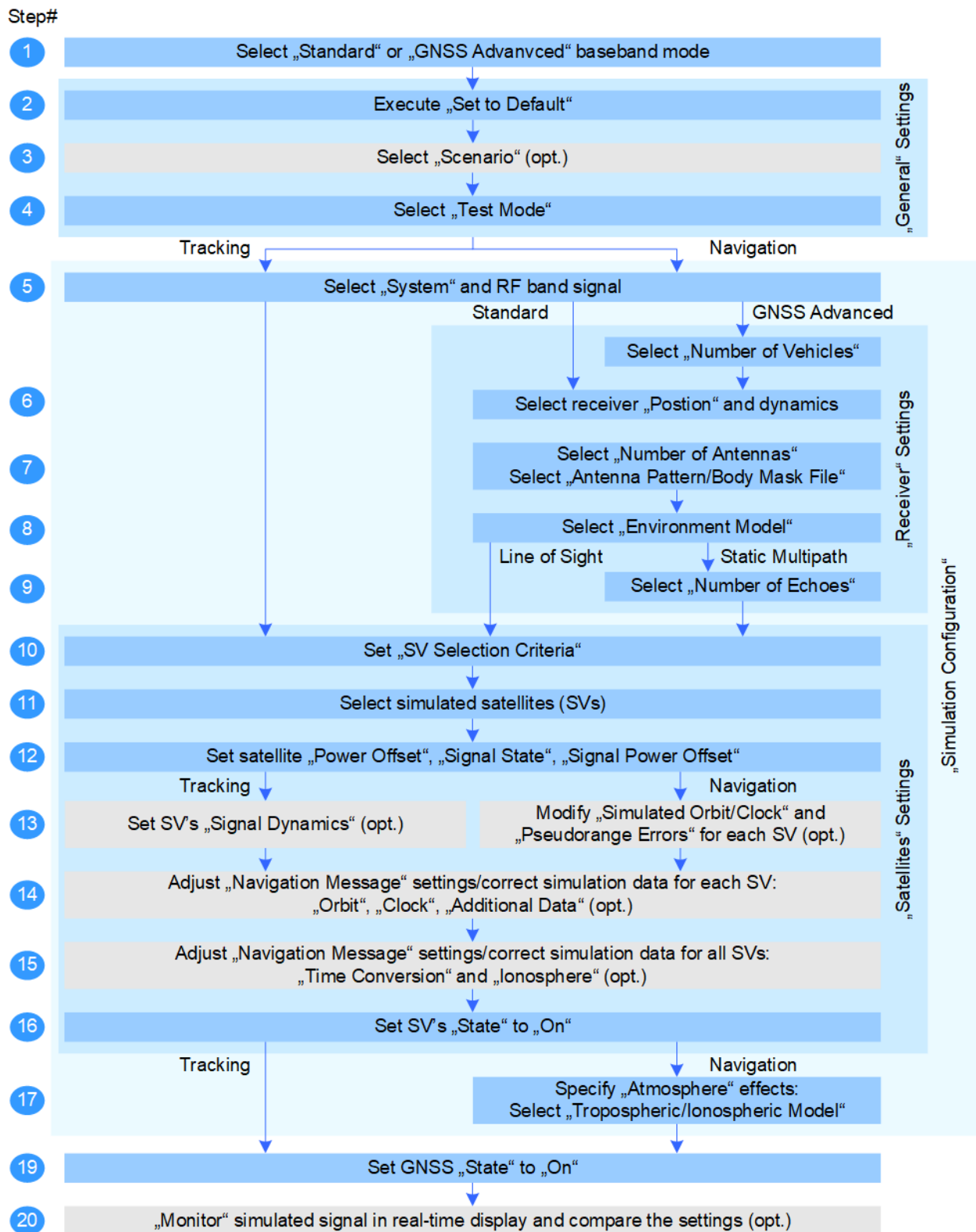

Figure 21-1: General workflow

21.2 Generating GNSS signals for simple receiver tests

See

- ["To generate a GNSS signal"](#) on page 28
- ["To generate a multi-constellation GNSS signal"](#) on page 31

21.3 Simulating real-world effects

For simulating antenna patterns and body masks, see:

- ["To load an antenna pattern/body mask file"](#) on page 114
- ["To simulate antenna pattern"](#) on page 115
- ["To change the antenna pattern"](#) on page 118
- ["To prepare for automotive applications"](#) on page 119
- ["To modify antenna attenuation and phase values"](#) on page 120
- ["To create an antenna pattern/body mask file"](#) on page 121

21.4 Adding noise or CW interferer

See

- ["To add noise to a GNSS signal"](#) on page 193
- ["To shift noise to one RF band"](#) on page 194
- ["To add a CW interferer to a GNSS signal"](#) on page 195

21.5 Loading historical data

See

- [Chapter 18.1, "Import constellation settings"](#), on page 310
- [Chapter 18.2, "Import SBAS settings"](#), on page 312
- [Chapter 14.3, "How to generate SBAS corrections"](#), on page 241

21.6 Generating GNSS advanced mode signals

See

- [Chapter 15.1.1, "How to enable GNSS advanced mode"](#), on page 268
- [Chapter 15.1.2, "How to set up multifrequency scenarios"](#), on page 270
- [Chapter 15.1.3, "How to set up multi-vehicle scenarios"](#), on page 275
- [Chapter 15.1.4, "How to set up multi-antenna scenarios"](#), on page 276

- [Chapter 15.1.5, "How to configure GNSS streams"](#), on page 278

22 Remote-control commands

The following commands are required for signal generation with the satellite navigation options in a remote environment. We assume that the R&S SMW200A has already been set up for remote operation in a network as described in the R&S SMW200A documentation. A knowledge about the remote control operation and the SCPI command syntax is assumed.



Conventions used in SCPI command descriptions

For a description of the conventions used in the remote command descriptions, see section "Remote Control Commands" in the R&S SMW200A user manual.

The `:SOURce<hw>:BB:GPS|GALileo|GLONass|BEIDou|NAVIC|QZSS` subsystem contains commands for configuring the GNSS standards.

Common suffixes

The following common suffixes are used in remote commands:

Suffix	Value range	Description
SOURce<hw>	[1] to 4	Available baseband signals
OUTPut<ch>	1 to 3	Available markers
SVID<ch>	1 to 37 for GPS 1 to 36 for Galileo 1 to 24 for GLONASS 1 to 35 for BeiDou 1 to 14 for NavIC 193 to 195 for QZSS	Distinguishes between satellite SV IDs
A<ch> A<gr>	1 to 4	Simulated antenna
BASE<st>	1	Simulated RTK base station
ECHO<s2us0>	1 to 9	Echoes in the multipath configuration
MONitor<ch>	1 to 2	Pane in the "Simulation Monitor" dialog
RF<ch>	1 to 2	RF paths for noise configuration
STReam<st>	1 to 6	Simulated GNSS stream
V<st> V<us>	1 to 2	Simulated vehicle

Required options

For an overview, see [Chapter 2.1, "Required options"](#), on page 17.

SCPI command contains	Required option
SYSTEM:GPS TIME:START:GPS TIME:CONVersion:GPS SVID<ch>:GPS SVID:GPS SV:SElection:GPS SV:IMPort:GPS ADGeneration:GPS	R&S SMW-K44 R&S SMW-K98
L2C L5S	R&S SMW-K98
SYSTEM:GALileo TIME:START:GALileo TIME:CONVersion:GALileo SVID<ch>:GALileo SVID:GALileo SV:SElection:GALileo SV:IMPort:GALileo ADGeneration:GALileo E1OS E5A E5B	R&S SMW-K66
SYSTEM:GLONnas TIME:START:GLONnas TIME:CONVersion:GLONnas SVID<ch>:GLONnas SVID:GLONnas SV:SElection:GLONnas SV:IMPort:GLONnas ADGeneration:GLONnas	R&S SMW-K94
SYSTEM:BEIDou TIME:START:BEIDou TIME:CONVersion:BEIDou SVID<ch>:BEIDou SVID:BEIDou SV:SElection:BEIDou SV:IMPort:BEIDou ADGeneration:BEIDou	R&S SMW-K107 R&S SMW-K132

SCPI command contains	Required option
SYSTem:NAVic TIME:STARt:NAVic TIME:CONVersion:NAVic SVID<ch>:NAVic SVID:NAVic SV:SElection:NAVic SV:IMPOrt:NAVic ADGeneration:NAVic	R&S SMW-K197
SBAS QZSS	R&S SMW-K106
RECeiver[:V<st>]:ATTitude RECeiver[:V<st>]:ENVironment MPATh	R&S SMW-K108
HIL	R&S SMW-K109
STReam<st> V<st>	R&S SMW-B9
BASE<st>	R&S SMW-B9 and R&S SMW-K122.

Programming examples

This section provides simple programming examples. The purpose of the examples is to present all commands for a given task. In real applications, you typically use an appropriate subset of these commands.

For verification and testing purposes, a software tool executed these programming examples. To keep the example as simple as possible, the examples report clean SCPI syntax elements. Non-executable command lines, for example comments, start with two characters `//`.

Before executing a SCPI sequence, most remote control programs reset or preset the instrument to a definite state. The commands `*RST` and `SYSTem:PRESet` are equivalent for this purpose. `*CLS` also resets the status registers and clears the output buffer.

The following commands specific to the GNSS options are described here:

- [General commands](#).....356
- [System and signal commands](#).....361
- [Time conversion configuration](#).....366
- [Receiver positioning configuration commands](#).....380
- [Antenna pattern and body mask](#).....389
- [Real-time kinematics \(RTK\) commands](#).....393
- [Environment configuration commands](#).....402
- [Static multipath configuration](#).....415
- [Atmospheric configuration commands](#).....428
- [AWGN configuration](#).....434
- [Satellites constellation](#).....438
- [Signals and power configuration per satellite](#).....448

• Navigation message commands.....	478
• Galileo OSNMA commands.....	566
• SBAS corrections.....	574
• Signal dynamics.....	585
• Assistance data commands.....	596
• Monitoring and real-time commands.....	603
• Data logging commands.....	624
• Advanced mode commands.....	630
• Trigger commands.....	639
• Marker commands.....	645
• Clock commands.....	649

22.1 General commands

Example: Save/Recall files with user settings

Query and load settings files, saved with the save/recall function.

```
MMEM:CDIR '/var/user/settings'
SOURCE1:BB:GNSS:SETTING:CATALOG?
// Response: gnss_settings,settings
SOURCE1:BB:GNSS:SETTING:STORE '/var/user/settings/gnss'
SOURCE1:BB:GNSS:SETTING:LOAD '/var/user/settings/gnss_settings'
SOURCE1:BB:GNSS:SETTING:DELETE '/var/user/settings/settings'
// Deletes the file settings.gnss
SOURCE1:BB:GNSS:SETTING:CATALOG?
// Response: gnss_settings,gnss
```

Example: Selecting a predefined test scenario

Enable a predefined scenario.

```
// *****
// Select and enable the predefined test scenario 3GPP FDD Signaling Test Scenario 2.
// *****
SOURCE1:BB:GNSS:PRESET
// Lists all predefined scenarios in a comma-separated list.
SOURCE1:BB:GNSS:SETTING:CATALOG:PREDEFINED?
// Response: "Assisted GNSS+EUTRA/LTE+3GPP TS 37.571-2: S7 Signaling ST1; ..."
SOURCE1:BB:GNSS:SETTING:LOAD:PREDEFINED "3GPP TS 37.571-2: S7 Signaling ST2"
SOURCE1:BB:GNSS:SCENARIO?
// Response: "3GPP TS 37.571-2: S7 Signaling ST2"
// Query simulation information.
SOURCE1:BB:GNSS:SIMULATION:INFO?
// Response: "L1 / GLONASS only"

SOURCE1:BB:GNSS:TMODE?
// Response: "NAV"
```

SOURce1:BB:GNSS:STATe ON

Commands:

<code>[:SOURce<hw>]:BB:GNSS:PRESet</code>	357
<code>[:SOURce<hw>]:BB:GNSS:STATe</code>	357
<code>[:SOURce<hw>]:BB:GNSS:SCENario?</code>	357
<code>[:SOURce<hw>]:BB:GNSS:TMODe</code>	358
<code>[:SOURce<hw>]:BB:GNSS:SIMulation:INFO?</code>	359
<code>[:SOURce<hw>]:BB:GNSS:SETTing:CATalog?</code>	359
<code>[:SOURce<hw>]:BB:GNSS:SETTing:STORe</code>	359
<code>[:SOURce<hw>]:BB:GNSS:SETTing:LOAD</code>	360
<code>[:SOURce<hw>]:BB:GNSS:SETTing:DELeTe</code>	360
<code>[:SOURce<hw>]:BB:GNSS:SETTing:CATalog:PREDeFined?</code>	360
<code>[:SOURce<hw>]:BB:GNSS:SETTing:LOAD:PREDeFined</code>	360

`[:SOURce<hw>]:BB:GNSS:PRESet`

Sets the parameters of the digital standard to their default values (*RST values specified for the commands).

Not affected is the state set with the command `SOURce<hw>:BB:GNSS:STATe`.

Example: See [Example "Selecting a predefined test scenario"](#) on page 356.

Usage: Event

Manual operation: See ["Set to Default"](#) on page 33

`[:SOURce<hw>]:BB:GNSS:STATe <State>`

Enables/disables the GNSS signal simulation.

Parameters:

<State> 1 | ON | 0 | OFF
*RST: 0

Example: See [Example "Selecting a predefined test scenario"](#) on page 356.

Manual operation: See ["State"](#) on page 33

`[:SOURce<hw>]:BB:GNSS:SCENario?`

Queries the current scenario.

Return values:

<Scenario> string
NONE
Indicates the preset configuration or a user-defined configuration.

Scenario name

Returns the scenario name of a predefined scenario, e.g. "3GPP TS 37.571-2: S7 Signaling ST1". See [Chapter E, "Predefined GNSS scenarios"](#), on page 670.

Filename

Returns the filename of a saved, user-defined scenario. The scenario file has the extension *.gnss.

Example: See [Example "Selecting a predefined test scenario"](#) on page 356.

Usage: Query only

Manual operation: See ["Scenario"](#) on page 34

[:SOURCE<hw>]:BB:GNSS:TMODE <SMode>

Sets the test mode.

Parameters:

<SMode>

NAVigation | TRACking | MSI | AMSI

NAVigation

Navigation mode

The generated signal contains satellite signals to simulate a particular location of a GNSS receiver.

This signal implies a realistic navigation scenario. The DUT can achieve position fix, since the satellite constellation comprises of at least three satellites. The signal is suitable for signal acquisition and TTFB tests.

TRACking

Tracking mode

The generated signal contains no positioning data. You do not need to configure the GNSS receiver. Navigation and acquiring of position fix is not possible.

The signal is sufficient to test the ability of the DUT to find the channel and to decode the signal. It is also sufficient for receiver sensitivity testing. Use this mode to simulate high signal dynamics. For example, simulate spinning vehicles and precision code (P code) signals.

MSI

Matched-spectrum interferer mode

The generated signal is a tracking mode signal that contains continuous wave (CW) interference signals for all space vehicles of a given satellite constellation. These signals have no navigation message data.

AMSI

Advanced matched-spectrum interferer mode

The generated signal is a navigation mode signal that contains continuous wave (CW) interference signals for all space vehicles of a given satellite constellation. These signals have no navigation message data.

*RST: NAVigation

Example: See [Example"Selecting a predefined test scenario"](#) on page 356.

Options: MSI|AMSI require option R&S SMW-K129.

Manual operation: See ["Test Mode"](#) on page 34

[[:SOURce<hw>]:BB:GNSS:SIMulation:INFO?

Queries information on the current enabled RF bands, signals and GNSS standards.

Return values:

<SimConfigInfo> string

Example: See [Example"Selecting a predefined test scenario"](#) on page 356.

Usage: Query only

[[:SOURce<hw>]:BB:GNSS:SETTing:CATalog?

Queries the files with settings in the default directory. Listed are files with the file extension *.gnss.

Example: See [Example"Save/Recall files with user settings"](#) on page 356.

Usage: Query only

Manual operation: See ["Recall Scenario/Save Scenario"](#) on page 33

[[:SOURce<hw>]:BB:GNSS:SETTing:STORe <Filename>

Saves the current settings into the selected file; the file extension (*.gnss) is assigned automatically.

Setting parameters:

<Filename> "<filename>"
Filename or complete file path

Example: See [Example"Save/Recall files with user settings"](#) on page 356.

Usage: Setting only

Manual operation: See ["Recall Scenario/Save Scenario"](#) on page 33

[:SOURce<hw>]:BB:GNSS:SETTing:LOAD <Filename>

Loads the selected file from the default or the specified directory. Loaded are files with extension *.gnss.

Setting parameters:

<Filename> "<filename>"
 Filename or complete file path; file extension can be omitted
 Query the existing files with the command [:SOURce<hw>] :
 BB:GNSS:SETTing:CATalog?.

Example: See [Example"Save/Recall files with user settings"](#) on page 356.

Usage: Setting only

Manual operation: See ["Recall Scenario/Save Scenario"](#) on page 33

[:SOURce<hw>]:BB:GNSS:SETTing:DELeTe <Filename>

Deletes the selected file from the default or the specified directory.

Setting parameters:

<Filename> "<filename>"
 Filename or complete file path; file extension can be omitted

Example: See [Example"Save/Recall files with user settings"](#) on page 356.

Usage: Setting only

Manual operation: See ["Recall Scenario/Save Scenario"](#) on page 33

[:SOURce<hw>]:BB:GNSS:SETTing:CATalog:PREDeFined?

Queries the files with predefined settings.

Example: See [Example"Selecting a predefined test scenario"](#)
 on page 356.

Usage: Query only

Manual operation: See ["Predefined Scenario"](#) on page 34

[:SOURce<hw>]:BB:GNSS:SETTing:LOAD:PREDeFined <Scenario>

Loads the selected scenario file.

Setting parameters:

<Scenario> "<ScenarioName>"
 Name of a predefined scenario, as queried with the command
 [:SOURce<hw>] :BB:GNSS:SETTing:CATalog:
 PREDeFined?.

Example: See [Example"Selecting a predefined test scenario"](#)
 on page 356.

Usage: Setting only

Manual operation: See "Predefined Scenario" on page 34

22.2 System and signal commands

Example: Enabling GNSS systems and signals

The example illustrates how to enable RF bands, GNSS systems and signals.

```

SCONfiguration:MODE GNSS
SCONfiguration:APPLY

SOURCEl:BB:GNSS:TMODe NAV
*****
// Enable and query RF band states.
*****
SOURCEl:BB:GNSS:L1Band:STATe 1
SOURCEl:BB:GNSS:L2Band:STATe? 0
SOURCEl:BB:GNSS:L5Band:STATe 1
*****
// Enable and query GNSS system states.
*****
SOURCEl:BB:GNSS:SYSTEM:GPS:STATe 1
SOURCEl:BB:GNSS:SYSTEM:GALileo:STATe 1
SOURCEl:BB:GNSS:SYSTEM:GLONass:STATe? 0
SOURCEl:BB:GNSS:SYSTEM:BEIDou:STATe? 0
SOURCEl:BB:GNSS:SYSTEM:NAVic:STATe? 0
SOURCEl:BB:GNSS:SYSTEM:QZSS:STATe? 0
*****
// Enable signals within GNSS systems and RF band.
*****
SOURCEl:BB:GNSS:SYSTEM:GPS:SIGNal:L1Band:P:STATe 1
SOURCEl:BB:GNSS:SYSTEM:GPS:SIGNal:L1Band:CA:STATe 1
SOURCEl:BB:GNSS:SYSTEM:GPS:SIGNal:L1Band:L1C:STATe 1
SOURCEl:BB:GNSS:SYSTEM:GPS:SIGNal:L2Band:CA:STATe 1
SOURCEl:BB:GNSS:SYSTEM:GPS:SIGNal:L2Band:L2C:STATe 1
SOURCEl:BB:GNSS:SYSTEM:GPS:SIGNal:L5Band:L5S:STATe 1
SOURCEl:BB:GNSS:SYSTEM:GALileo:SIGNal:L1Band:E1OS:STATe 1
*****
// Query other GPS and Galileo signal states.
*****
SOURCEl:BB:GNSS:SYSTEM:GPS:SIGNal:L1Band:M:STATe?
// Response: 0
SOURCEl:BB:GNSS:SYSTEM:GPS:SIGNal:L1Band:PY:STATe?
// Response: 0
SOURCEl:BB:GNSS:SYSTEM:GPS:SIGNal:L2Band:M:STATe?
// Response: 0

```

```

SOURCE1:BB:GNSS:SYSTEM:GPS:SIGNAL:L2Band:PY:STATE?
// Response: 0
SOURCE1:BB:GNSS:SYSTEM:GALileo:SIGNAL:L2Band:E6S:STATE?
// Response: 0
SOURCE1:BB:GNSS:SYSTEM:GALileo:SIGNAL:L2Band:E6PRs:STATE?
// Response: 0
SOURCE1:BB:GNSS:SYSTEM:GALileo:SIGNAL:L5Band:E5A:STATE?
// Response: 0
SOURCE1:BB:GNSS:SYSTEM:GALileo:SIGNAL:L5Band:E5B:STATE?
// Response: 0
SOURCE1:BB:GNSS:SYSTEM:GALileo:SIGNAL:L2Band:E1PRs:STATE?
// Response: 0
// All other signals are also disabled, e.g.:
SOURCE1:BB:GNSS:SYSTEM:GLONASS:SIGNAL:L1Band:CA:STATE?
// Response: 0

*****
// Query information on active RF bands, central RF frequency and GNSS systems.
*****

SOURCE1:BB:GNSS:SIMULATION:INFO?
// Response: "L1,L2,L5 / GPS,Galileo"
SOURCE1:BB:GNSS:CFREQUENCY?
// Response in Hz: 1389225000

```

Commands:

[SOURCE<hw>]:BB:GNSS:CFREQUENCY?	363
[SOURCE<hw>]:BB:GNSS:L5Band[:STATE]	363
[SOURCE<hw>]:BB:GNSS:L2Band[:STATE]	363
[SOURCE<hw>]:BB:GNSS:L1Band[:STATE]	363
[SOURCE<hw>]:BB:GNSS:SYSTEM:SBAS:EGNOS[:STATE]	364
[SOURCE<hw>]:BB:GNSS:SYSTEM:SBAS:GAGAN[:STATE]	364
[SOURCE<hw>]:BB:GNSS:SYSTEM:SBAS:MSAS[:STATE]	364
[SOURCE<hw>]:BB:GNSS:SYSTEM:SBAS:WAAS[:STATE]	364
[SOURCE<hw>]:BB:GNSS:SYSTEM:NAVIC[:STATE]	364
[SOURCE<hw>]:BB:GNSS:SYSTEM:QZSS[:STATE]	364
[SOURCE<hw>]:BB:GNSS:SYSTEM:BEIDOU[:STATE]	364
[SOURCE<hw>]:BB:GNSS:SYSTEM:GLONASS[:STATE]	364
[SOURCE<hw>]:BB:GNSS:SYSTEM:GALileo[:STATE]	364
[SOURCE<hw>]:BB:GNSS:SYSTEM:GPS[:STATE]	364
[SOURCE<hw>]:BB:GNSS:SYSTEM:SBAS[:STATE]?	364
[SOURCE<hw>]:BB:GNSS:SYSTEM:SBAS:SIGNAL:L5Band:EL5S[:STATE]	365
[SOURCE<hw>]:BB:GNSS:SYSTEM:SBAS:SIGNAL:L1Band:CA[:STATE]	365
[SOURCE<hw>]:BB:GNSS:SYSTEM:NAVIC:SIGNAL:L5Band:SPS[:STATE]	365
[SOURCE<hw>]:BB:GNSS:SYSTEM:QZSS:SIGNAL:L5Band:L5S[:STATE]	365
[SOURCE<hw>]:BB:GNSS:SYSTEM:QZSS:SIGNAL:L2Band:L2C[:STATE]	365
[SOURCE<hw>]:BB:GNSS:SYSTEM:QZSS:SIGNAL:L1Band:L1C[:STATE]	365
[SOURCE<hw>]:BB:GNSS:SYSTEM:QZSS:SIGNAL:L1Band:CA[:STATE]	365
[SOURCE<hw>]:BB:GNSS:SYSTEM:BEIDOU:SIGNAL:L5Band:B2I[:STATE]	365
[SOURCE<hw>]:BB:GNSS:SYSTEM:BEIDOU:SIGNAL:L5Band:B2A[:STATE]	365
[SOURCE<hw>]:BB:GNSS:SYSTEM:BEIDOU:SIGNAL:L5Band:B2B[:STATE]	365

<code>[:SOURce<hw>]:BB:GNSS:SYSTem:BEIDou:SIGNal:L2Band:B3I[:STATe]</code>	365
<code>[:SOURce<hw>]:BB:GNSS:SYSTem:BEIDou:SIGNal:L1Band:B1I[:STATe]</code>	365
<code>[:SOURce<hw>]:BB:GNSS:SYSTem:BEIDou:SIGNal:L1Band:B1C[:STATe]</code>	365
<code>[:SOURce<hw>]:BB:GNSS:SYSTem:GLONass:SIGNal:L1Band:CA[:STATe]</code>	365
<code>[:SOURce<hw>]:BB:GNSS:SYSTem:GLONass:SIGNal:L1Band:L1CDma[:STATe]</code>	365
<code>[:SOURce<hw>]:BB:GNSS:SYSTem:GLONass:SIGNal:L2Band:CA[:STATe]</code>	365
<code>[:SOURce<hw>]:BB:GNSS:SYSTem:GLONass:SIGNal:L2Band:L2CDma[:STATe]</code>	365
<code>[:SOURce<hw>]:BB:GNSS:SYSTem:GLONass:SIGNal:L5Band:L3CDma[:STATe]</code>	365
<code>[:SOURce<hw>]:BB:GNSS:SYSTem:GALileo:SIGNal:L2Band:E6PRs[:STATe]</code>	365
<code>[:SOURce<hw>]:BB:GNSS:SYSTem:GALileo:SIGNal:L2Band:E6S[:STATe]</code>	365
<code>[:SOURce<hw>]:BB:GNSS:SYSTem:GALileo:SIGNal:L5Band:E5B[:STATe]</code>	365
<code>[:SOURce<hw>]:BB:GNSS:SYSTem:GALileo:SIGNal:L5Band:E5A[:STATe]</code>	365
<code>[:SOURce<hw>]:BB:GNSS:SYSTem:GALileo:SIGNal:L1Band:E1OS[:STATe]</code>	365
<code>[:SOURce<hw>]:BB:GNSS:SYSTem:GALileo:SIGNal:L1Band:E1PRs[:STATe]</code>	365
<code>[:SOURce<hw>]:BB:GNSS:SYSTem:GPS:SIGNal:L5Band:L5S[:STATe]</code>	366
<code>[:SOURce<hw>]:BB:GNSS:SYSTem:GPS:SIGNal:L2Band:L2C[:STATe]</code>	366
<code>[:SOURce<hw>]:BB:GNSS:SYSTem:GPS:SIGNal:L2Band:M[:STATe]</code>	366
<code>[:SOURce<hw>]:BB:GNSS:SYSTem:GPS:SIGNal:L2Band:P[:STATe]</code>	366
<code>[:SOURce<hw>]:BB:GNSS:SYSTem:GPS:SIGNal:L2Band:PY[:STATe]</code>	366
<code>[:SOURce<hw>]:BB:GNSS:SYSTem:GPS:SIGNal:L2Band:CA[:STATe]</code>	366
<code>[:SOURce<hw>]:BB:GNSS:SYSTem:GPS:SIGNal:L1Band:L1C[:STATe]</code>	366
<code>[:SOURce<hw>]:BB:GNSS:SYSTem:GPS:SIGNal:L1Band:M[:STATe]</code>	366
<code>[:SOURce<hw>]:BB:GNSS:SYSTem:GPS:SIGNal:L1Band:P[:STATe]</code>	366
<code>[:SOURce<hw>]:BB:GNSS:SYSTem:GPS:SIGNal:L1Band:PY[:STATe]</code>	366
<code>[:SOURce<hw>]:BB:GNSS:SYSTem:GPS:SIGNal:L1Band:CA[:STATe]</code>	366

`[:SOURce<hw>]:BB:GNSS:CFRequency?`

Queries the central RF frequency. The response is a mean value depending on enabled RF bands and GNSS systems.

Return values:

<CentralRfFreq> integer
 Range: 1E9 to 2E9
 *RST: 1E9
 Default unit: Hz

Example: See [Chapter 22.2, "System and signal commands"](#), on page 361.

Usage: Query only

`[:SOURce<hw>]:BB:GNSS:L5Band[:STATe]` <L5BandState>
`[:SOURce<hw>]:BB:GNSS:L2Band[:STATe]` <L2BandState>
`[:SOURce<hw>]:BB:GNSS:L1Band[:STATe]` <L1BandState>

Activates the RF band.

Parameters:

<L1BandState> 1 | ON | 0 | OFF
 *RST: 0

Manual operation: See "[L# Band](#)" on page 70

```
[ :SOURce<hw>]:BB:GNSS:SYSTem:SBAS:EGNOS[:STATe] <State>
[:SOURce<hw>]:BB:GNSS:SYSTem:SBAS:GAGAN[:STATe] <State>
[:SOURce<hw>]:BB:GNSS:SYSTem:SBAS:MSAS[:STATe] <State>
[:SOURce<hw>]:BB:GNSS:SYSTem:SBAS:WAAS[:STATe] <State>
[:SOURce<hw>]:BB:GNSS:SYSTem:NAVic[:STATe] <State>
[:SOURce<hw>]:BB:GNSS:SYSTem:QZSS[:STATe] <State>
[:SOURce<hw>]:BB:GNSS:SYSTem:BEIDou[:STATe] <State>
[:SOURce<hw>]:BB:GNSS:SYSTem:GLONass[:STATe] <State>
[:SOURce<hw>]:BB:GNSS:SYSTem:GALileo[:STATe] <State>
[:SOURce<hw>]:BB:GNSS:SYSTem:GPS[:STATe] <State>
```

Defines if satellites from the selected GNSS system are included in the simulated satellites constellation.

Parameters:

<State> 1 | ON | 0 | OFF

Disabling a GNSS system deactivates all SVID and signals from this system.

*RST: 0

Example: See [Example"Enabling GNSS systems and signals"](#) on page 361.

Manual operation: See "[System](#)" on page 70

```
[ :SOURce<hw>]:BB:GNSS:SYSTem:SBAS[:STATe]?
```

Queries if at least one of the SBAS system is enabled.

Return values:

<State> 1 | ON | 0 | OFF

1

At least one SBAS system is enabled.

To enable each of the SBAS systems, use the corresponding command, e.g. `[:SOURce<hw>]:BB:GNSS:SYSTem:SBAS:EGNOS[:STATe]`.

0

All SBAS systems are disabled.

*RST: 0

Example: See [Example"Enabling GNSS systems and signals"](#) on page 361.

Usage: Query only

```

[:SOURce<hw>]:BB:GNSS:SYSTem:SBAS:SIGNal:L5Band:EL5S[:STATe]
<SignalState>
[:SOURce<hw>]:BB:GNSS:SYSTem:SBAS:SIGNal:L1Band:CA[:STATe]
<SignalState>
[:SOURce<hw>]:BB:GNSS:SYSTem:NAVic:SIGNal:L5Band:SPS[:STATe]
<SignalState>
[:SOURce<hw>]:BB:GNSS:SYSTem:QZSS:SIGNal:L5Band:L5S[:STATe]
<SignalState>
[:SOURce<hw>]:BB:GNSS:SYSTem:QZSS:SIGNal:L2Band:L2C[:STATe]
<SignalState>
[:SOURce<hw>]:BB:GNSS:SYSTem:QZSS:SIGNal:L1Band:L1C[:STATe]
<SignalState>
[:SOURce<hw>]:BB:GNSS:SYSTem:QZSS:SIGNal:L1Band:CA[:STATe]
<SignalState>
[:SOURce<hw>]:BB:GNSS:SYSTem:BEIDou:SIGNal:L5Band:B2I[:STATe]
<SignalState>
[:SOURce<hw>]:BB:GNSS:SYSTem:BEIDou:SIGNal:L5Band:B2A[:STATe]
<SignalState>
[:SOURce<hw>]:BB:GNSS:SYSTem:BEIDou:SIGNal:L5Band:B2B[:STATe]
<SignalState>
[:SOURce<hw>]:BB:GNSS:SYSTem:BEIDou:SIGNal:L2Band:B3I[:STATe]
<SignalState>
[:SOURce<hw>]:BB:GNSS:SYSTem:BEIDou:SIGNal:L1Band:B1I[:STATe]
<SignalState>
[:SOURce<hw>]:BB:GNSS:SYSTem:BEIDou:SIGNal:L1Band:B1C[:STATe]
<SignalState>
[:SOURce<hw>]:BB:GNSS:SYSTem:GLONass:SIGNal:L1Band:CA[:STATe]
<SignalState>
[:SOURce<hw>]:BB:GNSS:SYSTem:GLONass:SIGNal:L1Band:L1CDma[:STATe]
<SignalState>
[:SOURce<hw>]:BB:GNSS:SYSTem:GLONass:SIGNal:L2Band:CA[:STATe]
<SignalState>
[:SOURce<hw>]:BB:GNSS:SYSTem:GLONass:SIGNal:L2Band:L2CDma[:STATe]
<SignalState>
[:SOURce<hw>]:BB:GNSS:SYSTem:GLONass:SIGNal:L5Band:L3CDma[:STATe]
<SignalState>
[:SOURce<hw>]:BB:GNSS:SYSTem:GALileo:SIGNal:L2Band:E6PRs[:STATe]
<SignalState>
[:SOURce<hw>]:BB:GNSS:SYSTem:GALileo:SIGNal:L2Band:E6S[:STATe]
<SignalState>
[:SOURce<hw>]:BB:GNSS:SYSTem:GALileo:SIGNal:L5Band:E5B[:STATe]
<SignalState>
[:SOURce<hw>]:BB:GNSS:SYSTem:GALileo:SIGNal:L5Band:E5A[:STATe]
<SignalState>
[:SOURce<hw>]:BB:GNSS:SYSTem:GALileo:SIGNal:L1Band:E1OS[:STATe]
<SignalState>
[:SOURce<hw>]:BB:GNSS:SYSTem:GALileo:SIGNal:L1Band:E1PRs[:STATe]
<SignalState>

```

```

[:SOURce<hw>]:BB:GNSS:SYSTEM:GPS:SIGNal:L5Band:L5S[:STATe]
    <SignalState>
[:SOURce<hw>]:BB:GNSS:SYSTEM:GPS:SIGNal:L2Band:L2C[:STATe]
    <SignalState>
[:SOURce<hw>]:BB:GNSS:SYSTEM:GPS:SIGNal:L2Band:M[:STATe] <SignalState>
[:SOURce<hw>]:BB:GNSS:SYSTEM:GPS:SIGNal:L2Band:P[:STATe] <SignalState>
[:SOURce<hw>]:BB:GNSS:SYSTEM:GPS:SIGNal:L2Band:PY[:STATe]
    <SignalState>
[:SOURce<hw>]:BB:GNSS:SYSTEM:GPS:SIGNal:L2Band:CA[:STATe]
    <SignalState>
[:SOURce<hw>]:BB:GNSS:SYSTEM:GPS:SIGNal:L1Band:L1C[:STATe]
    <SignalState>
[:SOURce<hw>]:BB:GNSS:SYSTEM:GPS:SIGNal:L1Band:M[:STATe] <SignalState>
[:SOURce<hw>]:BB:GNSS:SYSTEM:GPS:SIGNal:L1Band:P[:STATe] <SignalState>
[:SOURce<hw>]:BB:GNSS:SYSTEM:GPS:SIGNal:L1Band:PY[:STATe]
    <SignalState>
[:SOURce<hw>]:BB:GNSS:SYSTEM:GPS:SIGNal:L1Band:CA[:STATe]
    <SignalState>

```

Enables the corresponding signal from the GNSS system in the corresponding RF band.

Parameters:

<SignalState> 1 | ON | 0 | OFF
 *RST: 0

Example: See [Example "Enabling GNSS systems and signals"](#) on page 361.

Manual operation: See ["Signals"](#) on page 71

22.3 Time conversion configuration

Example: Configuring the time conversion and leap seconds settings

The example illustrate how to define simulation start and how to configure time settings.

```

*****
// Set test mode and activate GNSS systems.
*****
SOURcel:BB:GNSS:TMODe NAV
SOURcel:BB:GNSS:SYSTEM:GPS:STATe 1
SOURcel:BB:GNSS:SYSTEM:GALileo:STATe 1
SOURcel:BB:GNSS:SYSTEM:GLONass:STATe 1
*****
// Set simulation start date and time in UTC format.
*****
SOURcel:BB:GNSS:TIME:START:TBASis UTC
SOURcel:BB:GNSS:TIME:START:DATE 2016,2,19

```

```

SOURCEl:BB:GNSS:TIME:START:TIME 7,0,0
// Query the simulation start in GPS format.
SOURCEl:BB:GNSS:TIME:START:TBASis GPS
SOURCEl:BB:GNSS:TIME:START:WNUMber?
// Response: 1884
SOURCEl:BB:GNSS:TIME:START:TOWeek?
// Response: 457216.3154372
*****
// Query week number and time of week for active GNSS systems.
*****
SOURCEl:BB:GNSS:TIME:START:GPS:WNUMber?
// Response: 1884
SOURCEl:BB:GNSS:TIME:START:GPS:TOWeek?
// 457216.3154372
SOURCEl:BB:GNSS:TIME:START:GALileo:WNUMber?
// Response: 1884
SOURCEl:BB:GNSS:TIME:START:GALileo:TOWeek?
// Response: 457210.078614114
SOURCEl:BB:GNSS:TIME:START:GLONass:DATE?
// Response: 2016,2,19
SOURCEl:BB:GNSS:TIME:START:GLONass:TIME?
// Response: 9,59,46.158
/ Set the simulation start to the current operating system time.
SOURCEl:BB:GNSS:TIME:START:SCTime
SOURCEl:BB:GNSS:TIME:START:DATE?
// Response: 2020,7,28
SOURCEl:BB:GNSS:TIME:START:TIME?
// Response: 11,35,0
*****
// Activate automatic leap second calculation.
*****
SOURCEl:BB:GNSS:TIME:CONVersion:LEAP:AUTO 1
SOURCEl:BB:GNSS:TIME:CONVersion:LEAP:DATE?
// Response: 2015,6,30
SOURCEl:BB:GNSS:TIME:CONVersion:LEAP:BEFOre?
// Response in seconds: 16
SOURCEl:BB:GNSS:TIME:CONVersion:LEAP:AFTEr?
// Response in seconds: 17
*****
// Set time conversion parameters for automatic time conversion.
*****
SOURCEl:BB:GNSS:TIME:CONVersion:GPS:UTC:WNOT 244
SOURCEl:BB:GNSS:TIME:CONVersion:GPS:UTC:TOT:UNSCaled 475200
SOURCEl:BB:GNSS:TIME:CONVersion:GPS:UTC:AONE:UNSCaled 0
SOURCEl:BB:GNSS:TIME:CONVersion:GPS:UTC:AZERo:UNSCaled 0
SOURCEl:BB:GNSS:TIME:CONVersion:GPS:UTC:IOFFset?
// Response: 16
SOURCEl:BB:GNSS:TIME:CONVersion:UTCSu:UTC:DATE?
// Response: 2014,2,19
SOURCEl:BB:GNSS:TIME:CONVersion:GLONass:UTC:AZERo:UNSCaled 0

```

Time conversion configuration

```
SOURce1:BB:GNSS:TIME:CONVersion:UTCsu:UTC:AZERo:UNSCaled 0
SOURce1:BB:GNSS:TIME:CONVersion:UTCsu:UTC:AONE:UNSCaled 0
// etc. for each GNSS system
```

Commands:

[SOURce<hw>]:BB:GNSS:TIME:START:DATE.....	370
[SOURce<hw>]:BB:GNSS:TIME:START:SCTime.....	371
[SOURce<hw>]:BB:GNSS:TIME:START:TBASis.....	371
[SOURce<hw>]:BB:GNSS:TIME:START:TIME.....	371
[SOURce<hw>]:BB:GNSS:TIME:START:TOWeek.....	372
[SOURce<hw>]:BB:GNSS:TIME:START:WNUMber.....	372
[SOURce<hw>]:BB:GNSS:TIME:CONVersion:LEAP:AUTO.....	372
[SOURce<hw>]:BB:GNSS:TIME:CONVersion:LEAP:SEConds:AFter.....	373
[SOURce<hw>]:BB:GNSS:TIME:CONVersion:LEAP:SEConds:BEFore.....	373
[SOURce<hw>]:BB:GNSS:TIME:CONVersion:LEAP:DATE.....	373
[SOURce<hw>]:BB:GNSS:TIME:START:UTC:DATE?.....	374
[SOURce<hw>]:BB:GNSS:TIME:START:GLONass:DATE?.....	374
[SOURce<hw>]:BB:GNSS:TIME:START:UTC:TIME?.....	374
[SOURce<hw>]:BB:GNSS:TIME:START:GLONass:TIME?.....	374
[SOURce<hw>]:BB:GNSS:TIME:START:SBAS:EGNOS:WNUMber?.....	374
[SOURce<hw>]:BB:GNSS:TIME:START:SBAS:GAGAN:WNUMber?.....	374
[SOURce<hw>]:BB:GNSS:TIME:START:SBAS:MSAS:WNUMber?.....	374
[SOURce<hw>]:BB:GNSS:TIME:START:SBAS:WAAS:WNUMber?.....	374
[SOURce<hw>]:BB:GNSS:TIME:START:NAVic:WNUMber?.....	374
[SOURce<hw>]:BB:GNSS:TIME:START:QZSS:WNUMber?.....	374
[SOURce<hw>]:BB:GNSS:TIME:START:BEIDou:WNUMber?.....	374
[SOURce<hw>]:BB:GNSS:TIME:START:GALileo:WNUMber?.....	374
[SOURce<hw>]:BB:GNSS:TIME:START:GPS:WNUMber?.....	374
[SOURce<hw>]:BB:GNSS:TIME:START:SBAS:EGNOS:TOWeek?.....	375
[SOURce<hw>]:BB:GNSS:TIME:START:SBAS:GAGAN:TOWeek?.....	375
[SOURce<hw>]:BB:GNSS:TIME:START:SBAS:MSAS:TOWeek?.....	375
[SOURce<hw>]:BB:GNSS:TIME:START:SBAS:WAAS:TOWeek?.....	375
[SOURce<hw>]:BB:GNSS:TIME:START:NAVic:TOWeek?.....	375
[SOURce<hw>]:BB:GNSS:TIME:START:QZSS:TOWeek?.....	375
[SOURce<hw>]:BB:GNSS:TIME:START:BEIDou:TOWeek?.....	375
[SOURce<hw>]:BB:GNSS:TIME:START:GALileo:TOWeek?.....	375
[SOURce<hw>]:BB:GNSS:TIME:START:GPS:TOWeek?.....	375
[SOURce<hw>]:BB:GNSS:TIME:START:UTC:OFFSet?.....	375
[SOURce<hw>]:BB:GNSS:TIME:START:SBAS:EGNOS:OFFSet?.....	375
[SOURce<hw>]:BB:GNSS:TIME:START:SBAS:GAGAN:OFFSet?.....	375
[SOURce<hw>]:BB:GNSS:TIME:START:SBAS:MSAS:OFFSet?.....	375
[SOURce<hw>]:BB:GNSS:TIME:START:NAVic:OFFSet?.....	375
[SOURce<hw>]:BB:GNSS:TIME:START:QZSS:OFFSet?.....	375
[SOURce<hw>]:BB:GNSS:TIME:START:BEIDou:OFFSet?.....	375
[SOURce<hw>]:BB:GNSS:TIME:START:GALileo:OFFSet?.....	375
[SOURce<hw>]:BB:GNSS:TIME:START:GLONass:OFFSet?.....	375
[SOURce<hw>]:BB:GNSS:TIME:START:GPS:OFFSet?.....	375
[SOURce<hw>]:BB:GNSS:TIME:CONVersion:UTCsu:UTC:WNOT.....	376
[SOURce<hw>]:BB:GNSS:TIME:CONVersion:SBAS:EGNOS:UTC:WNOT.....	376

Time conversion configuration

[SOURce<hw>]:BB:GNSS:TIME:CONVersion:SBAS:GAGAN:UTC:WNOT.....	376
[SOURce<hw>]:BB:GNSS:TIME:CONVersion:SBAS:MSAS:UTC:WNOT.....	376
[SOURce<hw>]:BB:GNSS:TIME:CONVersion:SBAS:WAAS:UTC:WNOT.....	376
[SOURce<hw>]:BB:GNSS:TIME:CONVersion:NAVic:UTC:WNOT.....	376
[SOURce<hw>]:BB:GNSS:TIME:CONVersion:QZSS:UTC:WNOT.....	376
[SOURce<hw>]:BB:GNSS:TIME:CONVersion:BEIDou:UTC:WNOT.....	376
[SOURce<hw>]:BB:GNSS:TIME:CONVersion:GALileo:UTC:WNOT.....	376
[SOURce<hw>]:BB:GNSS:TIME:CONVersion:GLONass:UTC:WNOT.....	376
[SOURce<hw>]:BB:GNSS:TIME:CONVersion:GLONass:UTCSu:WNOT.....	376
[SOURce<hw>]:BB:GNSS:TIME:CONVersion:GPS:UTC:WNOT.....	376
[SOURce<hw>]:BB:GNSS:TIME:CONVersion:UTCSu:UTC:DATE?.....	376
[SOURce<hw>]:BB:GNSS:TIME:CONVersion:UTCSu:UTC:TOT:UNSCaled.....	377
[SOURce<hw>]:BB:GNSS:TIME:CONVersion:UTCSu:UTC:TOT.....	377
[SOURce<hw>]:BB:GNSS:TIME:CONVersion:SBAS:EGNOS:UTC:TOT:UNSCaled.....	377
[SOURce<hw>]:BB:GNSS:TIME:CONVersion:SBAS:EGNOS:UTC:TOT.....	377
[SOURce<hw>]:BB:GNSS:TIME:CONVersion:SBAS:GAGAN:UTC:TOT:UNSCaled.....	377
[SOURce<hw>]:BB:GNSS:TIME:CONVersion:SBAS:GAGAN:UTC:TOT.....	377
[SOURce<hw>]:BB:GNSS:TIME:CONVersion:SBAS:MSAS:UTC:TOT:UNSCaled.....	377
[SOURce<hw>]:BB:GNSS:TIME:CONVersion:SBAS:MSAS:UTC:TOT.....	377
[SOURce<hw>]:BB:GNSS:TIME:CONVersion:SBAS:WAAS:UTC:TOT:UNSCaled.....	377
[SOURce<hw>]:BB:GNSS:TIME:CONVersion:SBAS:WAAS:UTC:TOT.....	377
[SOURce<hw>]:BB:GNSS:TIME:CONVersion:NAVic:UTC:TOT:UNSCaled.....	377
[SOURce<hw>]:BB:GNSS:TIME:CONVersion:NAVic:UTC:TOT.....	377
[SOURce<hw>]:BB:GNSS:TIME:CONVersion:QZSS:UTC:TOT:UNSCaled.....	377
[SOURce<hw>]:BB:GNSS:TIME:CONVersion:QZSS:UTC:TOT.....	377
[SOURce<hw>]:BB:GNSS:TIME:CONVersion:BEIDou:UTC:TOT:UNSCaled.....	377
[SOURce<hw>]:BB:GNSS:TIME:CONVersion:BEIDou:UTC:TOT.....	377
[SOURce<hw>]:BB:GNSS:TIME:CONVersion:GALileo:UTC:TOT:UNSCaled.....	377
[SOURce<hw>]:BB:GNSS:TIME:CONVersion:GALileo:UTC:TOT.....	377
[SOURce<hw>]:BB:GNSS:TIME:CONVersion:GLONass:UTC:TOT:UNSCaled.....	377
[SOURce<hw>]:BB:GNSS:TIME:CONVersion:GLONass:UTC:TOT.....	377
[SOURce<hw>]:BB:GNSS:TIME:CONVersion:GLONass:UTCSu:TOT:UNSCaled.....	377
[SOURce<hw>]:BB:GNSS:TIME:CONVersion:GLONass:UTCSu:TOT.....	377
[SOURce<hw>]:BB:GNSS:TIME:CONVersion:GPS:UTC:TOT:UNSCaled.....	377
[SOURce<hw>]:BB:GNSS:TIME:CONVersion:GPS:UTC:TOT.....	377
[SOURce<hw>]:BB:GNSS:TIME:CONVersion:UTCSu:UTC:IOFFset?.....	378
[SOURce<hw>]:BB:GNSS:TIME:CONVersion:SBAS:EGNOS:UTC:IOFFset?.....	378
[SOURce<hw>]:BB:GNSS:TIME:CONVersion:SBAS:GAGAN:UTC:IOFFset?.....	378
[SOURce<hw>]:BB:GNSS:TIME:CONVersion:SBAS:MSAS:UTC:IOFFset?.....	378
[SOURce<hw>]:BB:GNSS:TIME:CONVersion:SBAS:WAAS:UTC:IOFFset?.....	378
[SOURce<hw>]:BB:GNSS:TIME:CONVersion:QZSS:UTC:IOFFset?.....	378
[SOURce<hw>]:BB:GNSS:TIME:CONVersion:NAVic:UTC:IOFFset?.....	378
[SOURce<hw>]:BB:GNSS:TIME:CONVersion:BEIDou:UTC:IOFFset?.....	378
[SOURce<hw>]:BB:GNSS:TIME:CONVersion:GALileo:UTC:IOFFset?.....	378
[SOURce<hw>]:BB:GNSS:TIME:CONVersion:GLONass:UTCSu:IOFFset?.....	378
[SOURce<hw>]:BB:GNSS:TIME:CONVersion:GPS:UTC:IOFFset?.....	378
[SOURce<hw>]:BB:GNSS:TIME:CONVersion:SBAS:EGNOS:UTC:AZERo:UNSCaled.....	378
[SOURce<hw>]:BB:GNSS:TIME:CONVersion:SBAS:EGNOS:UTC:AZERo.....	378
[SOURce<hw>]:BB:GNSS:TIME:CONVersion:SBAS:GAGAN:UTC:AZERo:UNSCaled.....	378
[SOURce<hw>]:BB:GNSS:TIME:CONVersion:SBAS:GAGAN:UTC:AZERo.....	378

Time conversion configuration

<code>[:SOURCE<hw>]:BB:GNSS:TIME:CONVersion:SBAS:MSAS:UTC:AZERo:UNSCaled</code>	378
<code>[:SOURCE<hw>]:BB:GNSS:TIME:CONVersion:SBAS:MSAS:UTC:AZERo</code>	378
<code>[:SOURCE<hw>]:BB:GNSS:TIME:CONVersion:SBAS:WAAS:UTC:AZERo:UNSCaled</code>	378
<code>[:SOURCE<hw>]:BB:GNSS:TIME:CONVersion:SBAS:WAAS:UTC:AZERo</code>	378
<code>[:SOURCE<hw>]:BB:GNSS:TIME:CONVersion:NAVic:UTC:AZERo:UNSCaled</code>	378
<code>[:SOURCE<hw>]:BB:GNSS:TIME:CONVersion:NAVic:UTC:AZERo</code>	378
<code>[:SOURCE<hw>]:BB:GNSS:TIME:CONVersion:QZSS:UTC:AZERo:UNSCaled</code>	378
<code>[:SOURCE<hw>]:BB:GNSS:TIME:CONVersion:QZSS:UTC:AZERo</code>	378
<code>[:SOURCE<hw>]:BB:GNSS:TIME:CONVersion:BEIDou:UTC:AZERo:UNSCaled</code>	378
<code>[:SOURCE<hw>]:BB:GNSS:TIME:CONVersion:BEIDou:UTC:AZERo</code>	378
<code>[:SOURCE<hw>]:BB:GNSS:TIME:CONVersion:GALileo:UTC:AZERo:UNSCaled</code>	379
<code>[:SOURCE<hw>]:BB:GNSS:TIME:CONVersion:GALileo:UTC:AZERo</code>	379
<code>[:SOURCE<hw>]:BB:GNSS:TIME:CONVersion:GLONass:UTC:AZERo:UNSCaled</code>	379
<code>[:SOURCE<hw>]:BB:GNSS:TIME:CONVersion:GLONass:UTC:AZERo</code>	379
<code>[:SOURCE<hw>]:BB:GNSS:TIME:CONVersion:GLONass:UTCSu:AZERo:UNSCaled</code>	379
<code>[:SOURCE<hw>]:BB:GNSS:TIME:CONVersion:GLONass:UTCSu:AZERo</code>	379
<code>[:SOURCE<hw>]:BB:GNSS:TIME:CONVersion:UTCSu:UTC:AZERo:UNSCaled</code>	379
<code>[:SOURCE<hw>]:BB:GNSS:TIME:CONVersion:UTCSu:UTC:AZERo</code>	379
<code>[:SOURCE<hw>]:BB:GNSS:TIME:CONVersion:GPS:UTC:AZERo:UNSCaled</code>	379
<code>[:SOURCE<hw>]:BB:GNSS:TIME:CONVersion:GPS:UTC:AZERo</code>	379
<code>[:SOURCE<hw>]:BB:GNSS:TIME:CONVersion:SBAS:EGNOS:UTC:AONE:UNSCaled</code>	379
<code>[:SOURCE<hw>]:BB:GNSS:TIME:CONVersion:SBAS:EGNOS:UTC:AONE</code>	379
<code>[:SOURCE<hw>]:BB:GNSS:TIME:CONVersion:SBAS:GAGAN:UTC:AONE:UNSCaled</code>	379
<code>[:SOURCE<hw>]:BB:GNSS:TIME:CONVersion:SBAS:GAGAN:UTC:AONE</code>	379
<code>[:SOURCE<hw>]:BB:GNSS:TIME:CONVersion:SBAS:MSAS:UTC:AONE:UNSCaled</code>	379
<code>[:SOURCE<hw>]:BB:GNSS:TIME:CONVersion:SBAS:MSAS:UTC:AONE</code>	379
<code>[:SOURCE<hw>]:BB:GNSS:TIME:CONVersion:SBAS:WAAS:UTC:AONE:UNSCaled</code>	379
<code>[:SOURCE<hw>]:BB:GNSS:TIME:CONVersion:SBAS:WAAS:UTC:AONE</code>	379
<code>[:SOURCE<hw>]:BB:GNSS:TIME:CONVersion:NAVic:UTC:AONE:UNSCaled</code>	379
<code>[:SOURCE<hw>]:BB:GNSS:TIME:CONVersion:NAVic:UTC:AONE</code>	379
<code>[:SOURCE<hw>]:BB:GNSS:TIME:CONVersion:QZSS:UTC:AONE:UNSCaled</code>	379
<code>[:SOURCE<hw>]:BB:GNSS:TIME:CONVersion:QZSS:UTC:AONE</code>	379
<code>[:SOURCE<hw>]:BB:GNSS:TIME:CONVersion:BEIDou:UTC:AONE:UNSCaled</code>	379
<code>[:SOURCE<hw>]:BB:GNSS:TIME:CONVersion:BEIDou:UTC:AONE</code>	379
<code>[:SOURCE<hw>]:BB:GNSS:TIME:CONVersion:GALileo:UTC:AONE:UNSCaled</code>	379
<code>[:SOURCE<hw>]:BB:GNSS:TIME:CONVersion:GALileo:UTC:AONE</code>	379
<code>[:SOURCE<hw>]:BB:GNSS:TIME:CONVersion:GLONass:UTC:AONE:UNSCaled</code>	379
<code>[:SOURCE<hw>]:BB:GNSS:TIME:CONVersion:GLONass:UTC:AONE</code>	380
<code>[:SOURCE<hw>]:BB:GNSS:TIME:CONVersion:GLONass:UTCSu:AONE:UNSCaled</code>	380
<code>[:SOURCE<hw>]:BB:GNSS:TIME:CONVersion:GLONass:UTCSu:AONE</code>	380
<code>[:SOURCE<hw>]:BB:GNSS:TIME:CONVersion:UTCSu:UTC:AONE:UNSCaled</code>	380
<code>[:SOURCE<hw>]:BB:GNSS:TIME:CONVersion:UTCSu:UTC:AONE</code>	380
<code>[:SOURCE<hw>]:BB:GNSS:TIME:CONVersion:GPS:UTC:AONE:UNSCaled</code>	380
<code>[:SOURCE<hw>]:BB:GNSS:TIME:CONVersion:GPS:UTC:AONE</code>	380

`[:SOURCE<hw>]:BB:GNSS:TIME:START:DATE` <Year>, <Month>, <Day>

If the time base is UTC, defines the date for the simulation in DD.MM.YYYY format of the Gregorian calendar.

Parameters:

<Year>	integer	
	Range:	1980 to 9999
<Month>	integer	
	Range:	1 to 12
<Day>	integer	
	Range:	1 to 31

Example: See [Example"Configuring the time conversion and leap seconds settings"](#) on page 366.

Manual operation: See ["Simulation Start"](#) on page 48

[[:SOURce<hw>]:BB:GNSS:TIME:START:SCTime

Applies date and time settings of the operating system to the simulation start time.

Example: See [Example"Configuring the time conversion and leap seconds settings"](#) on page 366.

Usage: Event

Manual operation: See ["Set Current Time"](#) on page 48

[[:SOURce<hw>]:BB:GNSS:TIME:START:TBASis <SystemTime>

Determines the time basis used to enter the simulation start time.

Parameters:

<SystemTime>	UTC GPS GST GLO BDT NAV
*RST:	UTC

Example: See [Example"Configuring the time conversion and leap seconds settings"](#) on page 366.

Manual operation: See ["Simulation Start"](#) on page 48

[[:SOURce<hw>]:BB:GNSS:TIME:START:TIME <Hour>, <Minute>, <Second>

If the time base is UTC, sets the simulation start time in UTC time format.

Parameters:

<Hour>	integer	
	Range:	0 to 23
<Minute>	integer	
	Range:	0 to 59
<Second>	float	
	Range:	0 to 59.999
	Increment:	0.001

Example: See [Example"Configuring the time conversion and leap seconds settings"](#) on page 366.

Manual operation: See ["Simulation Start"](#) on page 48

[:SOURce<hw>]:BB:GNSS:TIME:START:TOWeek <TOW>

If time base is GPS or GST, sets the simulation start time within week set with the command `[:SOURce<hw>]:BB:GNSS:TIME:START:WNUMber`.

Parameters:

<TOW> float
 Number of seconds since the beginning of the week
 Range: 0 to 604799.999
 Increment: 0.001
 *RST: 0

Example: See [Example"Configuring the time conversion and leap seconds settings"](#) on page 366.

Manual operation: See ["Simulation Start"](#) on page 48

[:SOURce<hw>]:BB:GNSS:TIME:START:WNUMber <Week>

If time base is GPS or GST, sets the week number (WN).

Parameters:

<Week> integer
 The weeks are numbered starting from a reference time point (WN_REF=0), that depends on the navigation standard.
 Range: 0 to 9999*53
 *RST: 0

Example: See [Example"Configuring the time conversion and leap seconds settings"](#) on page 366.

Manual operation: See ["Simulation Start"](#) on page 48

[:SOURce<hw>]:BB:GNSS:TIME:CONVersion:LEAP:AUTO <AutoConfigure>

Enables the simulation of the leap second transition.

Parameters:

<AutoConfigure> 1 | ON | 0 | OFF
 *RST: 1

Example: See [Example"Configuring the time conversion and leap seconds settings"](#) on page 366.

Manual operation: See ["Auto Configure Leap Second \(Ref. 1980\)"](#) on page 49

[[:SOURce<hw>]:BB:GNSS:TIME:CONVersion:LEAP:SECONDS:AFTer
 <LeapSeconds>

Specifies the leap second value after the leap second transition.

Parameters:

<LeapSeconds> integer
 Range: 0 to 50
 *RST: 17

Example: See [Example"Configuring the time conversion and leap seconds settings"](#) on page 366.

Manual operation: See "[Leap Second after Transition - \$\Delta t_{LSF}\$](#) " on page 49

[[:SOURce<hw>]:BB:GNSS:TIME:CONVersion:LEAP:SECONDS:BEFORE
 <LeapSeconds>

Specifies the leap second value before the leap second transition.

Parameters:

<LeapSeconds> integer
 Range: 0 to 50
 *RST: 16

Example: See [Example"Configuring the time conversion and leap seconds settings"](#) on page 366.

Manual operation: See "[Leap Second before Transition - \$\Delta t_{LS}\$](#) " on page 49

[[:SOURce<hw>]:BB:GNSS:TIME:CONVersion:LEAP:DATE <Year>, <Month>,
 <Day>

Defines the date of the next UTC time correction.

Parameters:

<Year> integer
 Range: 1980 to 9999
 <Month> integer
 Range: 1 to 12
 <Day> integer
 Range: 1 to 31

Example: See [Example"Configuring the time conversion and leap seconds settings"](#) on page 366.

Manual operation: See "[Leap Second Transition Date](#)" on page 49

```
[ :SOURce<hw>]:BB:GNSS:TIME:START:UTC:DATE?
```

```
[ :SOURce<hw>]:BB:GNSS:TIME:START:GLONASS:DATE?
```

Queries the date at the simulation start time of the selected navigation standard.

Return values:

<Year>	integer	
	Range:	1980 to 9999
<Month>	integer	
	Range:	1 to 12
<Day>	integer	
	Range:	1 to 31

Example: See [Example "Configuring the time conversion and leap seconds settings"](#) on page 366.

Usage: Query only

```
[ :SOURce<hw>]:BB:GNSS:TIME:START:UTC:TIME?
```

```
[ :SOURce<hw>]:BB:GNSS:TIME:START:GLONASS:TIME?
```

Queries the simulation start time of the selected navigation standard.

Return values:

<Hour>	integer	
	Range:	0 to 23
<Minute>	integer	
	Range:	0 to 59
<Second>	float	
	Range:	0 to 59.999
	Increment:	0.001

Example: See [Example "Configuring the time conversion and leap seconds settings"](#) on page 366.

Usage: Query only

```
[ :SOURce<hw>]:BB:GNSS:TIME:START:SBAS:EGNOS:WNUMBER?
```

```
[ :SOURce<hw>]:BB:GNSS:TIME:START:SBAS:GAGAN:WNUMBER?
```

```
[ :SOURce<hw>]:BB:GNSS:TIME:START:SBAS:MSAS:WNUMBER?
```

```
[ :SOURce<hw>]:BB:GNSS:TIME:START:SBAS:WAAS:WNUMBER?
```

```
[ :SOURce<hw>]:BB:GNSS:TIME:START:NAVIC:WNUMBER?
```

```
[ :SOURce<hw>]:BB:GNSS:TIME:START:QZSS:WNUMBER?
```

```
[ :SOURce<hw>]:BB:GNSS:TIME:START:BEIDOU:WNUMBER?
```

```
[ :SOURce<hw>]:BB:GNSS:TIME:START:GALILEO:WNUMBER?
```

```
[ :SOURce<hw>]:BB:GNSS:TIME:START:GPS:WNUMBER?
```

Queries the week number at the simulation start of the selected navigation standard.

Return values:

<SystemWeekNumb> integer

Range: 0 to 10000

*RST: 0

Example:See [Example"Configuring the time conversion and leap seconds settings"](#) on page 366.**Usage:**

Query only

Manual operation:See ["Date / Week, Time / Time of Week /s, UTC Offset /s"](#) on page 50

```
[:SOURce<hw>]:BB:GNSS:TIME:START:SBAS:EGNOS:TOWeek?
[:SOURce<hw>]:BB:GNSS:TIME:START:SBAS:GAGAN:TOWeek?
[:SOURce<hw>]:BB:GNSS:TIME:START:SBAS:MSAS:TOWeek?
[:SOURce<hw>]:BB:GNSS:TIME:START:SBAS:WAAS:TOWeek?
[:SOURce<hw>]:BB:GNSS:TIME:START:NAVIC:TOWeek?
[:SOURce<hw>]:BB:GNSS:TIME:START:QZSS:TOWeek?
[:SOURce<hw>]:BB:GNSS:TIME:START:BEIDOU:TOWeek?
[:SOURce<hw>]:BB:GNSS:TIME:START:GALILEO:TOWeek?
[:SOURce<hw>]:BB:GNSS:TIME:START:GPS:TOWeek?
```

Queries the time of week at the simulation start of the selected navigation standard.

Return values:

<TOW>

float

Range: 0 to 604799.999

Increment: 0.001

*RST: 0

Example:See [Example"Configuring the time conversion and leap seconds settings"](#) on page 366.**Usage:**

Query only

Manual operation:See ["Date / Week, Time / Time of Week /s, UTC Offset /s"](#) on page 50

```
[:SOURce<hw>]:BB:GNSS:TIME:START:UTC:OFFSet?
[:SOURce<hw>]:BB:GNSS:TIME:START:SBAS:EGNOS:OFFSet?
[:SOURce<hw>]:BB:GNSS:TIME:START:SBAS:GAGAN:OFFSet?
[:SOURce<hw>]:BB:GNSS:TIME:START:SBAS:MSAS:OFFSet?
[:SOURce<hw>]:BB:GNSS:TIME:START:NAVIC:OFFSet?
[:SOURce<hw>]:BB:GNSS:TIME:START:QZSS:OFFSet?
[:SOURce<hw>]:BB:GNSS:TIME:START:BEIDOU:OFFSet?
[:SOURce<hw>]:BB:GNSS:TIME:START:GALILEO:OFFSet?
[:SOURce<hw>]:BB:GNSS:TIME:START:GLONASS:OFFSet?
[:SOURce<hw>]:BB:GNSS:TIME:START:GPS:OFFSet?
```

Queries the time offset between the time in the navigation standard and UTC.

Return values:

<UtcOffset> float
 Range: -1E6 to 1E6
 Increment: 0.001
 *RST: 0

Example: See [Example"Configuring the time conversion and leap seconds settings"](#) on page 366.

Usage: Query only

Manual operation: See ["Date / Week, Time / Time of Week /s, UTC Offset /s"](#) on page 50

```
[:SOURCE<hw>]:BB:GNSS:TIME:CONVersion:UTCSu:UTC:WNOT <Wnot>
[:SOURCE<hw>]:BB:GNSS:TIME:CONVersion:SBAS:EGNOS:UTC:WNOT <Wnot>
[:SOURCE<hw>]:BB:GNSS:TIME:CONVersion:SBAS:GAGAN:UTC:WNOT <Wnot>
[:SOURCE<hw>]:BB:GNSS:TIME:CONVersion:SBAS:MSAS:UTC:WNOT <Wnot>
[:SOURCE<hw>]:BB:GNSS:TIME:CONVersion:SBAS:WAAS:UTC:WNOT <Wnot>
[:SOURCE<hw>]:BB:GNSS:TIME:CONVersion:NAVic:UTC:WNOT <Wnot>
[:SOURCE<hw>]:BB:GNSS:TIME:CONVersion:QZSS:UTC:WNOT <Wnot>
[:SOURCE<hw>]:BB:GNSS:TIME:CONVersion:BEIDou:UTC:WNOT <Wnot>
[:SOURCE<hw>]:BB:GNSS:TIME:CONVersion:GALileo:UTC:WNOT <Wnot>
[:SOURCE<hw>]:BB:GNSS:TIME:CONVersion:GLONass:UTC:WNOT <Wnot>
[:SOURCE<hw>]:BB:GNSS:TIME:CONVersion:GLONass:UTCSu:WNOT <Wnot>
[:SOURCE<hw>]:BB:GNSS:TIME:CONVersion:GPS:UTC:WNOT <Wnot>
```

Sets the UTC data reference week number, WN_t.

Parameters:

<Wnot> integer
 Range: 0 to 255
 *RST: 0

Example: See [Example"Configuring the time conversion and leap seconds settings"](#) on page 366.

Manual operation: See ["Reference Week/Date, Reference Time of Week"](#) on page 50

```
[:SOURCE<hw>]:BB:GNSS:TIME:CONVersion:UTCSu:UTC:DATE?
```

Enters the date for the UTC-UTC(SU) data in DMS format.

Return values:

<Year> integer
 Range: 1996 to 9999

<Month> integer
 Range: 1 to 12

<Day> integer

Range: 1 to 31

Example: See [Example"Configuring the time conversion and leap seconds settings"](#) on page 366.

Usage: Query only

Manual operation: See ["UTC-UTC\(SU\)"](#) on page 50

```
[ :SOURce<hw>]:BB:GNSS:TIME:CONVersion:UTCSu:UTC:TOT:UNSCaled <Tot>
[:SOURce<hw>]:BB:GNSS:TIME:CONVersion:UTCSu:UTC:TOT <Tot>
[:SOURce<hw>]:BB:GNSS:TIME:CONVersion:SBAS:EGNOS:UTC:TOT:UNSCaled
<Tot>
[:SOURce<hw>]:BB:GNSS:TIME:CONVersion:SBAS:EGNOS:UTC:TOT <Tot>
[:SOURce<hw>]:BB:GNSS:TIME:CONVersion:SBAS:GAGAN:UTC:TOT:UNSCaled
<Tot>
[:SOURce<hw>]:BB:GNSS:TIME:CONVersion:SBAS:GAGAN:UTC:TOT <Tot>
[:SOURce<hw>]:BB:GNSS:TIME:CONVersion:SBAS:MSAS:UTC:TOT:UNSCaled
<Tot>
[:SOURce<hw>]:BB:GNSS:TIME:CONVersion:SBAS:MSAS:UTC:TOT <Tot>
[:SOURce<hw>]:BB:GNSS:TIME:CONVersion:SBAS:WAAS:UTC:TOT:UNSCaled
<Tot>
[:SOURce<hw>]:BB:GNSS:TIME:CONVersion:SBAS:WAAS:UTC:TOT <Tot>
[:SOURce<hw>]:BB:GNSS:TIME:CONVersion:NAVic:UTC:TOT:UNSCaled <Tot>
[:SOURce<hw>]:BB:GNSS:TIME:CONVersion:NAVic:UTC:TOT <Tot>
[:SOURce<hw>]:BB:GNSS:TIME:CONVersion:QZSS:UTC:TOT:UNSCaled <Tot>
[:SOURce<hw>]:BB:GNSS:TIME:CONVersion:QZSS:UTC:TOT <Tot>
[:SOURce<hw>]:BB:GNSS:TIME:CONVersion:BEIDou:UTC:TOT:UNSCaled <Tot>
[:SOURce<hw>]:BB:GNSS:TIME:CONVersion:BEIDou:UTC:TOT <Tot>
[:SOURce<hw>]:BB:GNSS:TIME:CONVersion:GALileo:UTC:TOT:UNSCaled <Tot>
[:SOURce<hw>]:BB:GNSS:TIME:CONVersion:GALileo:UTC:TOT <Tot>
[:SOURce<hw>]:BB:GNSS:TIME:CONVersion:GLONass:UTC:TOT:UNSCaled
<Tot>
[:SOURce<hw>]:BB:GNSS:TIME:CONVersion:GLONass:UTC:TOT <Tot>
[:SOURce<hw>]:BB:GNSS:TIME:CONVersion:GLONass:UTCSu:TOT:UNSCaled
<Tot>
[:SOURce<hw>]:BB:GNSS:TIME:CONVersion:GLONass:UTCSu:TOT <Tot>
[:SOURce<hw>]:BB:GNSS:TIME:CONVersion:GPS:UTC:TOT:UNSCaled <Tot>
[:SOURce<hw>]:BB:GNSS:TIME:CONVersion:GPS:UTC:TOT <Tot>
```

Sets the UTC data reference time of week, t_{ot} .

Parameters:

<Tot> integer

Range: 0 to 255

*RST: 0

Example: See [Example"Configuring the time conversion and leap seconds settings"](#) on page 366.

Manual operation: See ["Reference Week/Date, Reference Time of Week"](#) on page 50

```
[ :SOURce<hw>]:BB:GNSS:TIME:CONVersion:UTC:IOFFset?
[:SOURce<hw>]:BB:GNSS:TIME:CONVersion:SBAS:EGNOS:UTC:IOFFset?
[:SOURce<hw>]:BB:GNSS:TIME:CONVersion:SBAS:GAGAN:UTC:IOFFset?
[:SOURce<hw>]:BB:GNSS:TIME:CONVersion:SBAS:MSAS:UTC:IOFFset?
[:SOURce<hw>]:BB:GNSS:TIME:CONVersion:SBAS:WAAS:UTC:IOFFset?
[:SOURce<hw>]:BB:GNSS:TIME:CONVersion:QZSS:UTC:IOFFset?
[:SOURce<hw>]:BB:GNSS:TIME:CONVersion:NAVic:UTC:IOFFset?
[:SOURce<hw>]:BB:GNSS:TIME:CONVersion:BEIDou:UTC:IOFFset?
[:SOURce<hw>]:BB:GNSS:TIME:CONVersion:GALileo:UTC:IOFFset?
[:SOURce<hw>]:BB:GNSS:TIME:CONVersion:GLONass:UTC:IOFFset?
[:SOURce<hw>]:BB:GNSS:TIME:CONVersion:GPS:UTC:IOFFset?
```

Queries the integer offset.

Return values:

```
<IntegerOffset>      integer
                      Range:    0 to 604800
                      *RST:    0
```

Example: See [Example"Configuring the time conversion and leap seconds settings"](#) on page 366.

Usage: Query only

Manual operation: See ["Integer Offset"](#) on page 50

```
[ :SOURce<hw>]:BB:GNSS:TIME:CONVersion:SBAS:EGNOS:UTC:AZERo:
UNSCaled <A0>
[:SOURce<hw>]:BB:GNSS:TIME:CONVersion:SBAS:EGNOS:UTC:AZERo
<AZero>
[:SOURce<hw>]:BB:GNSS:TIME:CONVersion:SBAS:GAGAN:UTC:AZERo:
UNSCaled <A0>
[:SOURce<hw>]:BB:GNSS:TIME:CONVersion:SBAS:GAGAN:UTC:AZERo
<AZero>
[:SOURce<hw>]:BB:GNSS:TIME:CONVersion:SBAS:MSAS:UTC:AZERo:
UNSCaled <A0>
[:SOURce<hw>]:BB:GNSS:TIME:CONVersion:SBAS:MSAS:UTC:AZERo <AZero>
[:SOURce<hw>]:BB:GNSS:TIME:CONVersion:SBAS:WAAS:UTC:AZERo:
UNSCaled <A0>
[:SOURce<hw>]:BB:GNSS:TIME:CONVersion:SBAS:WAAS:UTC:AZERo <AZero>
[:SOURce<hw>]:BB:GNSS:TIME:CONVersion:NAVic:UTC:AZERo:UNSCaled <A0>
[:SOURce<hw>]:BB:GNSS:TIME:CONVersion:NAVic:UTC:AZERo <AZero>
[:SOURce<hw>]:BB:GNSS:TIME:CONVersion:QZSS:UTC:AZERo:UNSCaled <A0>
[:SOURce<hw>]:BB:GNSS:TIME:CONVersion:QZSS:UTC:AZERo <AZero>
[:SOURce<hw>]:BB:GNSS:TIME:CONVersion:BEIDou:UTC:AZERo:UNSCaled
<A0>
[:SOURce<hw>]:BB:GNSS:TIME:CONVersion:BEIDou:UTC:AZERo <AZero>
```

```

[:SOURce<hw>]:BB:GNSS:TIME:CONVersion:GALileo:UTC:AZERo:UNSCaled
  <A0>
[:SOURce<hw>]:BB:GNSS:TIME:CONVersion:GALileo:UTC:AZERo <AZero>
[:SOURce<hw>]:BB:GNSS:TIME:CONVersion:GLONass:UTC:AZERo:UNSCaled
  <A0>
[:SOURce<hw>]:BB:GNSS:TIME:CONVersion:GLONass:UTC:AZERo <AZero>
[:SOURce<hw>]:BB:GNSS:TIME:CONVersion:GLONass:UTCSu:AZERo:
  UNSCaled <A0>
[:SOURce<hw>]:BB:GNSS:TIME:CONVersion:GLONass:UTCSu:AZERo <AZero>
[:SOURce<hw>]:BB:GNSS:TIME:CONVersion:UTCSu:UTC:AZERo:UNSCaled
  <A0>
[:SOURce<hw>]:BB:GNSS:TIME:CONVersion:UTCSu:UTC:AZERo <AZero>
[:SOURce<hw>]:BB:GNSS:TIME:CONVersion:GPS:UTC:AZERo:UNSCaled <A0>
[:SOURce<hw>]:BB:GNSS:TIME:CONVersion:GPS:UTC:AZERo <AZero>

```

Sets the constant term of polynomial, A_0 .

Parameters:

<AZero>	integer
Range:	-2147483648 to 2147483647
*RST:	0

Example: See [Example"Configuring the time conversion and leap seconds settings"](#) on page 366.

Manual operation: See ["Fractional Offset A0, Drift A1"](#) on page 51

```

[:SOURce<hw>]:BB:GNSS:TIME:CONVersion:SBAS:EGNOS:UTC:AONE:
  UNSCaled <A1>
[:SOURce<hw>]:BB:GNSS:TIME:CONVersion:SBAS:EGNOS:UTC:AONE <AOne>
[:SOURce<hw>]:BB:GNSS:TIME:CONVersion:SBAS:GAGAN:UTC:AONE:
  UNSCaled <A1>
[:SOURce<hw>]:BB:GNSS:TIME:CONVersion:SBAS:GAGAN:UTC:AONE <AOne>
[:SOURce<hw>]:BB:GNSS:TIME:CONVersion:SBAS:MSAS:UTC:AONE:UNSCaled
  <A1>
[:SOURce<hw>]:BB:GNSS:TIME:CONVersion:SBAS:MSAS:UTC:AONE <AOne>
[:SOURce<hw>]:BB:GNSS:TIME:CONVersion:SBAS:WAAS:UTC:AONE:
  UNSCaled <A1>
[:SOURce<hw>]:BB:GNSS:TIME:CONVersion:SBAS:WAAS:UTC:AONE <AOne>
[:SOURce<hw>]:BB:GNSS:TIME:CONVersion:NAVic:UTC:AONE:UNSCaled <A1>
[:SOURce<hw>]:BB:GNSS:TIME:CONVersion:NAVic:UTC:AONE <AOne>
[:SOURce<hw>]:BB:GNSS:TIME:CONVersion:QZSS:UTC:AONE:UNSCaled <A1>
[:SOURce<hw>]:BB:GNSS:TIME:CONVersion:QZSS:UTC:AONE <AOne>
[:SOURce<hw>]:BB:GNSS:TIME:CONVersion:BEIDou:UTC:AONE:UNSCaled
  <A1>
[:SOURce<hw>]:BB:GNSS:TIME:CONVersion:BEIDou:UTC:AONE <AOne>
[:SOURce<hw>]:BB:GNSS:TIME:CONVersion:GALileo:UTC:AONE:UNSCaled
  <A1>
[:SOURce<hw>]:BB:GNSS:TIME:CONVersion:GALileo:UTC:AONE <AOne>
[:SOURce<hw>]:BB:GNSS:TIME:CONVersion:GLONass:UTC:AONE:UNSCaled
  <A1>

```

```
[:SOURce<hw>]:BB:GNSS:TIME:CONVersion:GLONass:UTC:AONE <AOne>
[:SOURce<hw>]:BB:GNSS:TIME:CONVersion:GLONass:UTCSu:AONE:UNSCaled
  <A1>
[:SOURce<hw>]:BB:GNSS:TIME:CONVersion:GLONass:UTCSu:AONE <AOne>
[:SOURce<hw>]:BB:GNSS:TIME:CONVersion:UTCSu:UTC:AONE:UNSCaled <A1>
[:SOURce<hw>]:BB:GNSS:TIME:CONVersion:UTCSu:UTC:AONE <AOne>
[:SOURce<hw>]:BB:GNSS:TIME:CONVersion:GPS:UTC:AONE:UNSCaled <A1>
[:SOURce<hw>]:BB:GNSS:TIME:CONVersion:GPS:UTC:AONE <AOne>
```

Sets the first order term of polynomial, A_1 .

Parameters:

<AOne>	integer
	Range: -8388608 to 8388607
	*RST: 0

Example: See [Example "Configuring the time conversion and leap seconds settings"](#) on page 366.

Manual operation: See ["Fractional Offset A0, Drift A1"](#) on page 51

22.4 Receiver positioning configuration commands

This section describes the commands for configuring the position of GNSS receivers.

Example: Setting the initial position of a receiver

```
// Select a user-defined position.
SOURcel:BB:GNSS:RECeiver:Vl:LOCation:CATalog?
// Response: "User Defined, Waypoints, New York, .."
SOURcel:BB:GNSS:RECeiver:Vl:LOCation:SElect "User Defined"

SOURcel:BB:GNSS:RECeiver:Vl:LOCation:COORDinates:RFRame WGS84
SOURcel:BB:GNSS:RECeiver:Vl:LOCation:COORDinates:FORMat DMS
SOURcel:BB:GNSS:RECeiver:Vl:LOCation:COORDinates:DMS:WGS?
// 11,35,0,EAST,48,9,0,NORT,508
SOURcel:BB:GNSS:RECeiver:Vl:LOCation:COORDinates:FORMat DEC
SOURcel:BB:GNSS:RECeiver:Vl:LOCation:COORDinates:DEC:WGS?
// 11.583333,48.150000,508
```

Example: Simulating attitude behavior of a static receiver

```
SOURcel:BB:GNSS:RECeiver:Vl:POSition STAT
// query predefined positions and select one of them
SOURcel:BB:GNSS:RECeiver:Vl:LOCation:CATalog?
// User Defined,Waypoints,New York,San Francisco,Beijing,Seoul,...
SOURcel:BB:GNSS:RECeiver:Vl:LOCation:SElect "Munich"

SOURcel:BB:GNSS:RECeiver:Vl:ATTitude:BEHaviour CONS
SOURcel:BB:GNSS:RECeiver:Vl:ATTitude:YAW 0
```

```
SOURcel:BB:GNSS:RECeiver:Vl:ATTitude:PITCh 0
SOURcel:BB:GNSS:RECeiver:Vl:ATTitude:ROLL 0
```

Example: Simulating a moving receiver

```
// Simulate a moving receiver, e.g. a car.
SOURcel:BB:GNSS:RECeiver:Vl:POSition MOV

// Query predefined waypoint files and select one of them
SOURcel:BB:GNSS:RECeiver:Vl:LOCation:WAYPoints:FILE "Munich_Car_Motion.xtd"
SOURcel:BB:GNSS:RECeiver:Vl:LOCation:WAYPoints:ROMode?
// SYCL
SOURcel:BB:GNSS:RECeiver:Vl:LOCation:WAYPoints:DURation?
// 109.8
SOURcel:BB:GNSS:RECeiver:Vl:LOCation:COORDinates:RFRame WGS84
SOURcel:BB:GNSS:RECeiver:Vl:LOCation:SMOVement?
// 0
SOURcel:BB:GNSS:RECeiver:Vl:ATTitude:BEHaviour?
// FILE

// Activate trajectory smoothening.
// query predefined vehicle description files
// select one of them
SOURcel:BB:GNSS:RECeiver:Vl:LOCation:SMOVement 1
SOURcel:BB:GNSS:RECeiver:Vl:ATTitude:BEHaviour?
// MOT
SOURcel:BB:GNSS:VEHicle:CATalog:PREDefined?
// Aircraft1,HiL_Big_Aircraft,HiL_Helicopter,HiL_Jet_Aircraft,...
SOURcel:BB:GNSS:RECeiver:Vl:LOCation:VEHicle:FILE "LandVehicle1.xvd"

// Simulate an airplane.
// Enable trajectory smoothening by using *.xvd file. Enable spinning.
SOURcel:BB:GNSS:RECeiver:Vl:LOCation:WAYPoints:FILE "Munich_Flight.xtd"
SOURcel:BB:GNSS:RECeiver:Vl:LOCation:SMOVement 1
SOURcel:BB:GNSS:RECeiver:Vl:ATTitude:BEHaviour MOT
SOURcel:BB:GNSS:RECeiver:Vl:LOCation:VEHicle:FILE "Small_Jet.xvd"
SOURcel:BB:GNSS:RECeiver:Vl:ATTitude:BEHaviour SPIN
SOURcel:BB:GNSS:RECeiver:Vl:ATTitude:SPIN:RATE 10
SOURcel:BB:GNSS:RECeiver:Vl:ATTitude:PITCh 10
SOURcel:BB:GNSS:RECeiver:Vl:ATTitude:YAW 15
SOURcel:BB:GNSS:RECeiver:Vl:ATTitude:ROLL 10

SOURcel:BB:GNSS:STATe 1
```

Example: Using user-defined vehicle description files

```
// Query the available vehicle description files and load one of them
:MMEM:CDIR "/var/user/myXVDFiles"
SOURcel:BB:GNSS:VEHicle:CATalog:USER?
// my_Pedestrian
SOURcel:BB:GNSS:RECeiver:Vl:LOCation:VEHicle:FILE "/var/user/myXVDFiles/my_Pedestrian.xvd"
```

Commands:

<code>[:SOURce<hw>]:BB:GNSS:RECeiver[V<st>]:POSition</code>	382
<code>[:SOURce<hw>]:BB:GNSS:RECeiver[V<st>]:LOCation:CATalog</code>	382
<code>[:SOURce<hw>]:BB:GNSS:RECeiver[V<st>]:LOCation[SELect]</code>	383
<code>[:SOURce<hw>]:BB:GNSS:RECeiver[V<st>]:LOCation:COORdinate:RFRame</code>	383
<code>[:SOURce<hw>]:BB:GNSS:RECeiver[V<st>]:LOCation:COORdinate:FORMat</code>	383
<code>[:SOURce<hw>]:BB:GNSS:RECeiver[V<st>]:LOCation:COORdinate:DECimal:PZ</code>	384
<code>[:SOURce<hw>]:BB:GNSS:RECeiver[V<st>]:LOCation:COORdinate:DECimal[WGS]</code>	384
<code>[:SOURce<hw>]:BB:GNSS:RECeiver[V<st>]:LOCation:COORdinate:DMS:PZ</code>	384
<code>[:SOURce<hw>]:BB:GNSS:RECeiver[V<st>]:LOCation:COORdinate:DMS[WGS]</code>	384
<code>[:SOURce<hw>]:BB:GNSS:RECeiver[V<st>]:ATTitude[BEHaviour]</code>	386
<code>[:SOURce<hw>]:BB:GNSS:RECeiver[V<st>]:ATTitude:YAW</code>	386
<code>[:SOURce<hw>]:BB:GNSS:RECeiver[V<st>]:ATTitude:PITCh</code>	386
<code>[:SOURce<hw>]:BB:GNSS:RECeiver[V<st>]:ATTitude:ROLL</code>	387
<code>[:SOURce<hw>]:BB:GNSS:RECeiver[V<st>]:ATTitude:SPIN:RATE</code>	387
<code>[:SOURce<hw>]:BB:GNSS:RECeiver[V<st>]:LOCation:WAYPoints:FILE</code>	387
<code>[:SOURce<hw>]:BB:GNSS:RECeiver[V<st>]:LOCation:WAYPoints:DURation</code>	387
<code>[:SOURce<hw>]:BB:GNSS:RECeiver[V<st>]:LOCation:WAYPoints:LENGth?</code>	388
<code>[:SOURce<hw>]:BB:GNSS:RECeiver[V<st>]:LOCation:WAYPoints:ROMode</code>	388
<code>[:SOURce<hw>]:BB:GNSS:RECeiver[V<st>]:LOCation:SMOVement</code>	388
<code>[:SOURce<hw>]:BB:GNSS:VEHicle:CATalog:PREDeFined?</code>	389
<code>[:SOURce<hw>]:BB:GNSS:VEHicle:CATalog:USER?</code>	389
<code>[:SOURce<hw>]:BB:GNSS:RECeiver[V<st>]:LOCation:VEHicle:FILE</code>	389

`[:SOURce<hw>]:BB:GNSS:RECeiver[V<st>]:POSition` <Positioning>

Sets what kind of receiver is simulated.

Parameters:

<Positioning> STATic | MOVing | HIL

Example: See [Example "Simulating attitude behavior of a static receiver"](#) on page 380.

Options: HIL requires R&S SMW-K109

Manual operation: See ["Position"](#) on page 53

`[:SOURce<hw>]:BB:GNSS:RECeiver[V<st>]:LOCation:CATalog`

Queries the names of predefined geographic locations of the GNSS receiver. The query returns a comma-separated list of available locations.

For predefined geographic locations, see [Table 5-1](#).

Example: See [Example "Setting the initial position of a receiver"](#) on page 380.

Manual operation: See ["Location, Initial Position"](#) on page 55

[[:SOURce<hw>]:BB:GNSS:RECEiver[:V<st>]:LOCation[:SElect] <Location>

Selects the geographic location of the GNSS receiver.

Parameters:

<Location> string

User Defined

Enables the definition of the "Latitude", "Longitude" and "Altitude" of the GNSS receiver with fixed position in the ECEF WGS84 coordinate system.

"<City>"

Selects one of the predefined geographic locations, see [Table 5-1](#). The parameters latitude, longitude and altitude are set according to the selected position.

Example: See [Example "Setting the initial position of a receiver"](#) on page 380.

Manual operation: See ["Location, Initial Position"](#) on page 55

[[:SOURce<hw>]:BB:GNSS:RECEiver[:V<st>]:LOCation:COORDinates:RFRame <ReferenceFrame>

Selects the reference frame used to define the receiver coordinates.

Parameters:

<ReferenceFrame> PZ90 | WGS84

*RST: WGS84

Example: See [Example "Simulating attitude behavior of a static receiver"](#) on page 380.

Manual operation: See ["Reference Frame"](#) on page 56

[[:SOURce<hw>]:BB:GNSS:RECEiver[:V<st>]:LOCation:COORDinates:FORMat <PositionFormat>

Sets the format in which the latitude and longitude are set.

Parameters:

<PositionFormat> DMS | DECimal

*RST: DMS

Example: See [Example "Setting the initial position of a receiver"](#) on page 380.

Manual operation: See ["Location Coordinates, Position Format"](#) on page 56

```
[ :SOURce<hw>]:BB:GNSS:RECEiver[:V<st>]:LOCation:COORDinates:DECimal:
PZ <Longitude>, <Latitude>, <Altitude>
```

```
[ :SOURce<hw>]:BB:GNSS:RECEiver[:V<st>]:LOCation:COORDinates:DECimal[:
WGS] <Longitude>, <Latitude>, <Altitude>
```

Defines the coordinates of the geographic location of the GNSS receiver in decimal format.

Parameters:

<Longitude>

float

Defines the longitude.

Range: -180 to 180

Increment: 1E-7

*RST: 0

<Latitude>

float

Defines the latitude.

Range: -90 to 90

Increment: 1E-7

*RST: 0

<Altitude>

float

Defines the altitude. The altitude value is in meters and is the height above the reference ellipsoid.

Range: -10E3 to 50E6

Increment: 0.01

*RST: 0

Example:

See [Example"Simulating attitude behavior of a static receiver"](#) on page 380.

Manual operation:

See "[Location Coordinates, Position Format](#)" on page 56

```
[ :SOURce<hw>]:BB:GNSS:RECEiver[:V<st>]:LOCation:COORDinates:DMS:PZ
<LongitudeDeg>, <LongitudeMin>, <LongitudeSec>, <LongitudeDir>,
<LatitudeDeg>, <LatitudeMin>, <LatitudeSec>, <LatitudeDir>, <Altitude>
```

```
[ :SOURce<hw>]:BB:GNSS:RECEiver[:V<st>]:LOCation:COORDinates:DMS[:
WGS] <LongitudeDeg>, <LongitudeMin>, <LongitudeSec>, <LongitudeDir>,
<LatitudeDeg>, <LatitudeMin>, <LatitudeSec>, <LatitudeDir>, <Altitude>
```

Defines the coordinates of the geographic location of the GNSS receiver in degrees, minutes and seconds.

Parameters:

<LongitudeDeg>

integer

Defines the longitude degrees.

Range: 0 to 180

*RST: 0

Receiver positioning configuration commands

<LongitudeMin>	integer Defines the longitude minutes. Range: 0 to 59 *RST: 0
<LongitudeSec>	float Defines the longitude seconds. Range: 0 to 59.999 Increment: 1E-4 *RST: 0
<LongitudeDir>	EAST WEST Defines the longitude direction. *RST: EAST
<LatitudeDeg>	integer Defines the latitude degrees. Range: 0 to 90 *RST: 0
<LatitudeMin>	integer Defines the latitude minutes. Range: 0 to 59 *RST: 0
<LatitudeSec>	float Defines the latitude seconds. Range: 0 to 59.999 Increment: 1E-4 *RST: 0
<LatitudeDir>	NORTH SOUTH Defines the latitude direction. *RST: NORT
<Altitude>	float Defines the altitude. The altitude value is in meters and is the height above the reference ellipsoid. Range: -10E3 to 50E6 Increment: 0.01 *RST: 0
Example:	See Example"Simulating attitude behavior of a static receiver" on page 380.
Manual operation:	See " Location Coordinates, Position Format " on page 56

**[[:SOURce<hw>]:BB:GNSS:RECEiver[:V<st>]:ATTitude[:BEHaviour]
<AtitudeBehaviour>**

Defines how the attitude information is defined.

Parameters:

<AtitudeBehaviour> CONSTant | FILE | MOTion | SPINning | REMote
 FILE enabled if smoothing is not used.

Example: See [Example"Simulating a moving receiver"](#) on page 381.

Options: CONSTant | FILE | MOTion | SPINning require R&S SMW-K108
 REMote requires R&S SMW-K109

Manual operation: See "[Attitude Behaviour](#)" on page 57

[[:SOURce<hw>]:BB:GNSS:RECEiver[:V<st>]:ATTitude:YAW <Yaw>

Sets the attitude parameter relative to the local horizon.

Parameters:

<Yaw> float
 Only for backward compatibility, the range of this command and
 waypoint file import is from -180 degrees to +360 degrees. The
 values are internally mapped to a range of 0 degrees to 360
 degrees.
 Range: 0 to 360
 Increment: 0.001
 *RST: 0

Example: See [Example"Simulating a moving receiver"](#) on page 381.

Manual operation: See "[Yaw / Heading, Pitch / Elevation, \(Start\) Roll / Bank](#)"
 on page 67

[[:SOURce<hw>]:BB:GNSS:RECEiver[:V<st>]:ATTitude:PITCH <Pitch>

Sets the attitude parameter relative to the local horizon.

Parameters:

<Pitch> float
 Values outside the value range are not supported.
 If you import trajectory files with out-of-range pitch value defini-
 tions, the set values are not considered. Convert the trajectory
 files respectively.
 Range: -90 to 90
 Increment: 0.001
 *RST: 0

Example: See [Example"Simulating a moving receiver"](#) on page 381.

Manual operation: See "[Yaw / Heading, Pitch / Elevation, \(Start\) Roll / Bank](#)"
 on page 67

[[:SOURce<hw>]:BB:GNSS:RECEiver[:V<st>]:ATTitude:ROLL <Roll>

Sets the attitude parameter relative to the local horizon.

Parameters:

<Roll> float
 Range: -180 to 180
 Increment: 0.001
 *RST: 0

Example: See [Example"Simulating a moving receiver"](#) on page 381.

Manual operation: See ["Yaw / Heading, Pitch / Elevation, \(Start\) Roll / Bank"](#) on page 67

[[:SOURce<hw>]:BB:GNSS:RECEiver[:V<st>]:ATTitude:SPIN:RATE <Rate>

Sets the constant rate of change of the roll.

Parameters:

<Rate> float
 Range: -400 to 400
 Increment: 0.01
 *RST: 0

Example: See [Example"Simulating a moving receiver"](#) on page 381.

Options: R&S SMW-K108

Manual operation: See ["Spinning Rate"](#) on page 67

**[[:SOURce<hw>]:BB:GNSS:RECEiver[:V<st>]:LOCation:WAYPoints:FILE
 <WayPoints>**

Selects a predefined or user-defined waypoint files to simulate a moving scenario.

Parameters:

<WayPoints> Filename or complete file path incl. extension
 Waypoint files have the extension *.txt, *.nmea, *.kml or
 *.xtd.

Example: See [Example"Simulating a moving receiver"](#) on page 381.

Manual operation: See ["Waypoint File"](#) on page 62

**[[:SOURce<hw>]:BB:GNSS:RECEiver[:V<st>]:LOCation:WAYPoints:DURATION
 <Duration>**

Queries the trajectory duration.

Parameters:

<Duration> float
 Range: 0 to INT_MAX
 Increment: 0.001
 *RST: 0

Example: See [Example "Simulating a moving receiver"](#) on page 381.

Manual operation: See ["Trajectory Length/Duration"](#) on page 63

[:SOURCE<hw>]:BB:GNSS:RECEIVER[V<st>]:LOCATION:WAYPOINTS:LENGTH?

Queries the trajectory length.

Return values:

<Length> integer
 Range: 0 to (double(INT_MAX))
 *RST: 0

Example: See [Example "Simulating a moving receiver"](#) on page 381.

Usage: Query only

Manual operation: See ["Trajectory Length/Duration"](#) on page 63

[:SOURCE<hw>]:BB:GNSS:RECEIVER[V<st>]:LOCATION:WAYPOINTS:ROMODE <RoMode>

Defines the way the waypoint/attitude file is processed.

Parameters:

<RoMode> CYCLIC | RTRIP | OWAY
 *RST: OWAY

Example: See [Example "Simulating a moving receiver"](#) on page 381.

Manual operation: See ["Readout Mode"](#) on page 63

[:SOURCE<hw>]:BB:GNSS:RECEIVER[V<st>]:LOCATION:SMOVMEMENT <SmoothMovement>

Applies an internal algorithm to smooth the trajectory.

Parameters:

<SmoothMovement> 1 | ON | 0 | OFF
 *RST: OFF

Example: See [Example "Simulating a moving receiver"](#) on page 381.

Manual operation: See ["Motion Behaviour"](#) on page 65

[:SOURce<hw>]:BB:GNSS:VEHicle:CATalog:PREDefined?

Queries the names of the predefined vehicle description files in the system directory.

Listed are files with the file extension * .xvd.

Example: See [Example"Simulating a moving receiver"](#) on page 381.

Usage: Query only

Manual operation: See ["Vehicle Description File"](#) on page 66

[:SOURce<hw>]:BB:GNSS:VEHicle:CATalog:USER?

Queries the names of the user-defined vehicle description files in the default or in a specific directory. Listed are files with the file extension * .xvd.

Example: See [Example"Using user-defined vehicle description files"](#) on page 381.

Usage: Query only

Manual operation: See ["Vehicle Description File"](#) on page 66

[:SOURce<hw>]:BB:GNSS:RECEiver[:V<st>]:LOCation:VEHicle:FILE <Filename>

Selects a predefined or user-defined vehicle description (* .xvd) file.

Parameters:

<Filename> Filename or complete file path; file extension is optional

Query the existing files with:

```
[ :SOURce<hw>]:BB:GNSS:VEHicle:CATalog:
PREDefined?
```

```
[ :SOURce<hw>]:BB:GNSS:VEHicle:CATalog:USER?
```

Example: See [Example"Simulating a moving receiver"](#) on page 381.

Manual operation: See ["Vehicle Description File"](#) on page 66

22.5 Antenna pattern and body mask

Option: R&S SMW-K108

Example: Selecting an antenna pattern and body mask file

```

SOURCE1:BB:GNSS:TMODe NAV
// Enable 2 antennas.
SOURCE1:BB:GNSS:RECeiver:V1:ANTenna:COUNT 2
SOURCE1:BB:GNSS:RECeiver:V1:ANTenna:DISPlay BODY
SOURCE1:BB:GNSS:RECeiver:V1:ANTenna:V3D 1
// Query the available body mask files and load a file.
SOURCE1:BB:GNSS:BODY:CATalog:PREDefined?
// Response: "Bus,Car_Medium,Car_Medium_OpenRoof,Car_Small, ..."

SOURCE1:BB:GNSS:RECeiver:V1:A1:BODY:FILE "Car_Medium_OpenRoof"
SOURCE1:BB:GNSS:RECeiver:V1:ANTenna:DISPlay POS
SOURCE1:BB:GNSS:RECeiver:V1:A1:DX 0.9
SOURCE1:BB:GNSS:RECeiver:V1:A1:DY 0
SOURCE1:BB:GNSS:RECeiver:V1:A1:DZ -0.6
SOURCE1:BB:GNSS:RECeiver:V1:A1:DHEading 0
SOURCE1:BB:GNSS:RECeiver:V1:A1:DElevation 5
SOURCE1:BB:GNSS:RECeiver:V1:A1:DBANK 0

// Query user-defined antenna pattern files.
SOURCE1:BB:GNSS:APATtern:CATalog:PREDefined?
SOURCE1:BB:GNSS:RECeiver:V1:A1:APATtern:FILE "/var/user/test_antenna"
SOURCE1:BB:GNSS:RECeiver:V1:A1:STATe 1

```

[:SOURCE<hw>]:BB:GNSS:RECeiver[V<st>]:ANTenna:COUNT	390
[:SOURCE<hw>]:BB:GNSS:RECeiver[V<st>]:ANTenna:DISPlay	391
[:SOURCE<hw>]:BB:GNSS:RECeiver[V<st>]:ANTenna:V3D	391
[:SOURCE<hw>]:BB:GNSS:BODY:CATalog:PREDefined	391
[:SOURCE<hw>]:BB:GNSS:APATtern:CATalog:PREDefined?	391
[:SOURCE<hw>]:BB:GNSS:BODY:CATalog:USER	391
[:SOURCE<hw>]:BB:GNSS:APATtern:CATalog:USER?	391
[:SOURCE<hw>]:BB:GNSS:RECeiver[V<st>]:A<ch>:BODY:FILE	392
[:SOURCE<hw>]:BB:GNSS:RECeiver[V<st>]:A<ch>:APATtern:FILE	392
[:SOURCE<hw>]:BB:GNSS:RECeiver[V<st>]:A<ch>:STATe	392
[:SOURCE<hw>]:BB:GNSS:RECeiver[V<st>]:A<ch>:DBANK	392
[:SOURCE<hw>]:BB:GNSS:RECeiver[V<st>]:A<ch>:DHEading	392
[:SOURCE<hw>]:BB:GNSS:RECeiver[V<st>]:A<ch>:DElevation	392
[:SOURCE<hw>]:BB:GNSS:RECeiver[V<st>]:A<ch>:DX	393
[:SOURCE<hw>]:BB:GNSS:RECeiver[V<st>]:A<ch>:DY	393
[:SOURCE<hw>]:BB:GNSS:RECeiver[V<st>]:A<ch>:DZ	393

[\[:SOURCE<hw>\]:BB:GNSS:RECeiver\[V<st>\]:ANTenna:COUNT](#)
 <NumberOfAntenna>

Set the numer of simulated antenas.

Parameters:

<NumberOfAntenna> integer

Range: 1 to 6

*RST: 1

Example: See [Example"Selecting an antenna pattern and body mask file"](#) on page 390.

Manual operation: See ["Number of Antennas"](#) on page 54

[:SOURce<hw>]:BB:GNSS:RECeiver[:V<st>]:ANTenna:DISPlay <AntennaView>

Select the antenna characteristics that are currently visualized.

Parameters:

<AntennaView> AATTenuation | APHase | BODY | POSition
*RST: POSition

Example: See [Example"Selecting an antenna pattern and body mask file"](#) on page 390.

Manual operation: See ["Display"](#) on page 127

[:SOURce<hw>]:BB:GNSS:RECeiver[:V<st>]:ANTenna:V3D <Visualize3D>

Activates the interactive 3D representation of the body mask or the power/phase distribution the antenna.

Parameters:

<Visualize3D> 1 | ON | 0 | OFF
*RST: 0

Example: See [Example"Selecting an antenna pattern and body mask file"](#) on page 390.

Manual operation: See ["3D View"](#) on page 128

[:SOURce<hw>]:BB:GNSS:BODY:CATalog:PREDefined

[:SOURce<hw>]:BB:GNSS:APATtern:CATalog:PREDefined?

Queries the names of the predefined antenna pattern/body mask files in the system directory.

Listed are files with the file extension *.ant_pat/*.body_mask.

Example: See [Example"Selecting an antenna pattern and body mask file"](#) on page 390.

Usage: Query only

Manual operation: See ["Body Mask, Antenna Pattern"](#) on page 128

[:SOURce<hw>]:BB:GNSS:BODY:CATalog:USER

[:SOURce<hw>]:BB:GNSS:APATtern:CATalog:USER?

Queries the names of the user-defined antenna pattern/body mask files in the default or in a specific directory. Listed are files with the file extension *.ant_pat/

*.body_mask.

Example: See [Example"Selecting an antenna pattern and body mask file"](#) on page 390.

Usage: Query only

Manual operation: See ["Body Mask, Antenna Pattern"](#) on page 128

```
[ :SOURce<hw>]:BB:GNSS:RECEiver[:V<st>]:A<ch>:BODY:FILE <BodyMaskFile>
[:SOURce<hw>]:BB:GNSS:RECEiver[:V<st>]:A<ch>:APATtern:FILE <Filename>
```

Loads the selected file from the default or the specified directory. Loaded are files with extension *.ant_pat/*.body_mask.

Parameters:

<Filename> "<filename>"
 Filename or complete file path; file extension can be omitted.
 Query the existing files with the following commands:
[\[:SOURce<hw>\]:BB:GNSS:APATtern:CATalog:PREDEfined?](#) on page 391
[\[:SOURce<hw>\]:BB:GNSS:APATtern:CATalog:USER?](#) on page 391

Example: See [Example"Selecting an antenna pattern and body mask file"](#) on page 390.

Manual operation: See ["Body Mask, Antenna Pattern"](#) on page 128

```
[ :SOURce<hw>]:BB:GNSS:RECEiver[:V<st>]:A<ch>:STATE <State>
```

Activates the antenna.

Parameters:

<State> 1 | ON | 0 | OFF

Example: See [Example"Selecting an antenna pattern and body mask file"](#) on page 390.

Manual operation: See ["Active"](#) on page 128

```
[ :SOURce<hw>]:BB:GNSS:RECEiver[:V<st>]:A<ch>:DBANK <DeltaBank>
[:SOURce<hw>]:BB:GNSS:RECEiver[:V<st>]:A<ch>:DHEading <DeltaHeading>
[:SOURce<hw>]:BB:GNSS:RECEiver[:V<st>]:A<ch>:DELEvation <DeltaElevation>
```

Sets the orientation and tilt of the antenna of the GNSS receiver.

The values are relative to the center of gravity (COG).

Parameters:

<DeltaElevation> float
 Range: -180 to 180
 Increment: 0.001
 *RST: 0

Example: See [Example "Selecting an antenna pattern and body mask file"](#) on page 390.

Manual operation: See ["Delta Heading, Delta Elevation, Delta Bank"](#) on page 129

```
[ :SOURce<hw>]:BB:GNSS:RECEiver[:V<st>]:A<ch>:DX <DeltaX>
[:SOURce<hw>]:BB:GNSS:RECEiver[:V<st>]:A<ch>:DY <DeltaY>
[:SOURce<hw>]:BB:GNSS:RECEiver[:V<st>]:A<ch>:DZ <DeltaZ>
```

Sets the antenna position of the GNSS receiver as an offset on the x, y and z axis.

The offset is relative to center of gravity (COG).

Parameters:

```
<DeltaZ>          float
                  Range:    -200 to 200
                  Increment: 0.001
                  *RST:     0
```

Example: See [Example "Selecting an antenna pattern and body mask file"](#) on page 390.

Manual operation: See ["Delta X, Delta Y, Delta Z"](#) on page 129

22.6 Real-time kinematics (RTK) commands

Option: R&S SMW-K122

The following examples provide a configuration of an RTK setup with one base station.

Example: Activating RTK simulation

```
// Query RTK simulation properties.
SOURce1:BB:GNSS:RTK:BSTation:COUNT?
// Response: "1"
// One RTK base station is simulated.
// Query base station 1 properties.
SOURce1:BB:GNSS:RTK:BASE1:MOUNTpoint?
// Response: "RS01"
SOURce1:BB:GNSS:RTK:STATe 1
```

Example: Configuring RTK base station location

```
// Specify location parameters of RTK base station 1.
// Select a user-defined position.
SOURCE1:BB:GNSS:RTK:BASE1:LOCATION:CATALOG?
// Response: "User Defined, New York, .."
SOURCE1:BB:GNSS:RTK:BASE1:LOCATION:SELECT "User Defined"
// Select the reference frame for the base station coordinates.
SOURCE1:BB:GNSS:RTK:BASE1:LOCATION:COORDINATES:RFRAME WGS84
SOURCE1:BB:GNSS:RTK:BASE1:LOCATION:COORDINATES:FORMAT DMS
SOURCE1:BB:GNSS:RTK:BASE1:LOCATION:COORDINATES:DMS:WGS?
// Response: "11,35,0,EAST,48,9,0,NORT,508"
SOURCE1:BB:GNSS:RTK:BASE1:LOCATION:COORDINATES:FORMAT DEC
SOURCE1:BB:GNSS:RTK:BASE1:LOCATION:COORDINATES:DEC:WGS?
// Response: "11.583333,48.150000,508"

// Optionally synchronize, that means update, the base station location with the
// current location of the GNSS receiver. Synchronization is successful for
// distances below 150 km between RTK base station and GNSS receiver.
SOURCE1:BB:GNSS:RTK:BASE1:LOCATION:SYNC
```

Example: Configuring RTK base station antenna

```
SOURCE1:BB:GNSS:RTK:BASE1:A1:BODY:FILE "Car_Medium_OpenRoof"
SOURCE1:BB:GNSS:RTK:BASE1:A1:DX 0.9
SOURCE1:BB:GNSS:RTK:BASE1:A1:DY 0
SOURCE1:BB:GNSS:RTK:BASE1:A1:DZ -0.6
SOURCE1:BB:GNSS:RTK:BASE1:A1:DHEADING 0
SOURCE1:BB:GNSS:RTK:BASE1:A1:DELEVATION 5
SOURCE1:BB:GNSS:RTK:BASE1:A1:DBANK 0

// Query user-defined antenna pattern files.
SOURCE1:BB:GNSS:APATTERN:CATALOG:PREDEFINED?
SOURCE1:BB:GNSS:RTK:BASE1:A1:APATTERN:FILE "/var/user/test_antenna"
SOURCE1:BB:GNSS:RTK:BASE1:A1:STATE 1
```

Example: Configuring real-time kinematics (RTK) protocol

```
// Query RTK simulation properties.
SOURCE1:BB:GNSS:RTK:BSTATION:COUNT?
// Response: "1"
// One RTK base station is simulated.
```

Commands:

- [RTK general commands](#)..... 395
- [RTK location commands](#)..... 395
- [RTK antenna commands](#)..... 399
- [RTK protocol commands](#)..... 401

22.6.1 RTK general commands

<code>[:SOURce<hw>]:BB:GNSS:RTK:BASE<st>:MOUNtpoint?</code>	395
<code>[:SOURce<hw>]:BB:GNSS:RTK:BSTation:COUNT</code>	395
<code>[:SOURce<hw>]:BB:GNSS:RTK:STATe</code>	395

`[:SOURce<hw>]:BB:GNSS:RTK:BASE<st>:MOUNtpoint?`

Sets the mountpoint for RTK simulation.

Return values:

<Mountpoint> string

Example: See [Example "Activating RTK simulation"](#) on page 393.

Usage: Query only

Manual operation: See ["Mountpoint"](#) on page 155

`[:SOURce<hw>]:BB:GNSS:RTK:BSTation:COUNT <NumberOfBases>`

Queries the number of RTK base stations.

Parameters:

<NumberOfBases> 1
 *RST: 1

Example: See [Example "Activating RTK simulation"](#) on page 393.

Manual operation: See ["Number of Base Stations"](#) on page 154

`[:SOURce<hw>]:BB:GNSS:RTK:STATe <RtkState>`

Activates real-time kinematics simulation.

Parameters:

<RtkState> 1 | ON | 0 | OFF
 *RST: 0

Example: See [Example "Activating RTK simulation"](#) on page 393.

Manual operation: See ["State"](#) on page 154

22.6.2 RTK location commands

<code>[:SOURce<hw>]:BB:GNSS:RTK:BASE<st>:LOCation:CATalog</code>	396
<code>[:SOURce<hw>]:BB:GNSS:RTK:BASE<st>:LOCation[:SELect]</code>	396
<code>[:SOURce<hw>]:BB:GNSS:RTK:BASE<st>:LOCation:COORdinateS:RFRame</code>	396
<code>[:SOURce<hw>]:BB:GNSS:RTK:BASE<st>:LOCation:COORdinateS:FORMat</code>	397
<code>[:SOURce<hw>]:BB:GNSS:RTK:BASE<st>:LOCation:COORdinateS:DECimal:PZ</code>	397
<code>[:SOURce<hw>]:BB:GNSS:RTK:BASE<st>:LOCation:COORdinateS:DECimal[:WGS]</code>	397

<code>[:SOURCE<hw>]:BB:GNSS:RTK:BASE<st>:LOCATION:COORDINATES:DMS:PZ.....</code>	398
<code>[:SOURCE<hw>]:BB:GNSS:RTK:BASE<st>:LOCATION:COORDINATES:DMS[:WGS].....</code>	398
<code>[:SOURCE<hw>]:BB:GNSS:RTK:BASE<st>:LOCATION:SYNC.....</code>	399

`[:SOURCE<hw>]:BB:GNSS:RTK:BASE<st>:LOCATION:CATALOG`

Queries the names of predefined geographic locations of the RTK base station. The query returns a comma-separated list of available locations.

For predefined geographic locations, see [Table 5-1](#).

Example: See [Example "Configuring RTK base station location"](#) on page 394.

Manual operation: See ["Location, Initial Position"](#) on page 55

`[:SOURCE<hw>]:BB:GNSS:RTK:BASE<st>:LOCATION[:SELECT] <Location>`

Selects the geographic location of the RTK base station.

Parameters:

<code><Location></code>	string
	"User Defined"
	Enables the definition of the "Latitude", "Longitude" and "Altitude" of the GNSS receiver with fixed position in the ECEF WGS84 coordinate system.
	"<City>"
	Selects one of the predefined geographic locations, see Table 5-1 . The parameters latitude, longitude and altitude are set according to the selected position.

Example: See [Example "Activating RTK simulation"](#) on page 393.

Manual operation: See ["Location, Initial Position"](#) on page 55

`[:SOURCE<hw>]:BB:GNSS:RTK:BASE<st>:LOCATION:COORDINATES:RFRAME <ReferenceFrame>`

Selects the reference frame used to define the RTK base station coordinates.

Parameters:

<code><ReferenceFrame></code>	PZ90 WGS84
	*RST: WGS84

Example: See [Example "Configuring RTK base station location"](#) on page 394.

Manual operation: See ["Reference Frame"](#) on page 56

```
[ :SOURce<hw>]:BB:GNSS:RTK:BASE<st>:LOCation:COORDinates:FORMat
<PositionFormat>
```

Sets the format in which the latitude and longitude are set.

Parameters:

```
<PositionFormat>  DMS | DECimal
*RST:             DMS
```

Example: See [Example"Configuring RTK base station location"](#) on page 394.

Manual operation: See ["Location Coordinates, Position Format"](#) on page 56

```
[ :SOURce<hw>]:BB:GNSS:RTK:BASE<st>:LOCation:COORDinates:DECimal:PZ
<Longitude>, <Latitude>, <Altitude>
[ :SOURce<hw>]:BB:GNSS:RTK:BASE<st>:LOCation:COORDinates:DECimal[ :
WGS] <Longitude>, <Latitude>, <Altitude>
```

Defines the coordinates of the geographic location of the RTK base station in decimal format.

Parameters:

```
<Longitude>      float
                  Defines the longitude in degrees.
                  Range:    -180 to 180
                  Increment: 1E-7
                  *RST:     0
```

```
<Latitude>      float
                  Defines the latitude in degrees.
                  Range:    -90 to 90
                  Increment: 1E-7
                  *RST:     0
```

```
<Altitude>     float
                  Defines the altitude. The altitude value is in meters and is the
                  height above the reference ellipsoid.
                  Range:    -10E3 to 50E6
                  Increment: 0.01
                  *RST:     0
```

Example: See [Example"Activating RTK simulation"](#) on page 393.

Manual operation: See ["Location Coordinates, Position Format"](#) on page 56

[[:SOURce<hw>]:BB:GNSS:RTK:BASE<st>:LOCation:COORDinates:DMS:PZ
 <LongitudeDeg>, <LongitudeMin>, <LongitudeSec>, <LongitudeDir>,
 <LatitudeDeg>, <LatitudeMin>, <LatitudeSec>, <LatitudeDir>, <Altitude>

[[:SOURce<hw>]:BB:GNSS:RTK:BASE<st>:LOCation:COORDinates:DMS[:WGS]

<LongitudeDeg>, <LongitudeMin>, <LongitudeSec>, <LongitudeDir>,
 <LatitudeDeg>, <LatitudeMin>, <LatitudeSec>, <LatitudeDir>, <Altitude>

Defines the coordinates of the geographic location of the RTK base station in degrees, minutes and seconds.

Parameters:

<LongitudeDeg>	integer	Defines the longitude degrees. Range: 0 to 180 *RST: 0
<LongitudeMin>	integer	Defines the longitude minutes. Range: 0 to 59 *RST: 0
<LongitudeSec>	float	Defines the longitude seconds. Range: 0 to 59.999 Increment: 1E-4 *RST: 0
<LongitudeDir>	EAST WEST	Defines the longitude direction. *RST: EAST
<LatitudeDeg>	integer	Defines the latitude degrees. Range: 0 to 90 *RST: 0
<LatitudeMin>	integer	Defines the latitude minutes. Range: 0 to 59 *RST: 0
<LatitudeSec>	float	Defines the latitude seconds. Range: 0 to 59.999 Increment: 1E-4 *RST: 0
<LatitudeDir>	NORTH SOUTH	Defines the latitude direction. *RST: NORT

<Altitude>	float
	Defines the altitude. The altitude value is in meters and is the height above the reference ellipsoid.
	Range: -10E3 to 50E6
	Increment: 0.01
	*RST: 0
Example:	See Example"Configuring RTK base station location" on page 394.
Manual operation:	See "Location Coordinates, Position Format" on page 56

[[:SOURce<hw>]:BB:GNSS:RTK:BASE<st>:LOCation:SYNC

Triggers synchronization of the RTK base station location and receiver location.

Example:	See Example"Activating RTK simulation" on page 393.
Usage:	Event
Manual operation:	See "Sync to Receiver Position" on page 157

22.6.3 RTK antenna commands

[:SOURce<hw>]:BB:GNSS:RTK:BASE<st>:A<ch>:BODY:FILE	399
[:SOURce<hw>]:BB:GNSS:RTK:BASE<st>:A<ch>:APATtern:FILE	399
[:SOURce<hw>]:BB:GNSS:RTK:BASE<st>:A<ch>:STATe	400
[:SOURce<hw>]:BB:GNSS:RTK:BASE<st>:A<ch>:DBANK	400
[:SOURce<hw>]:BB:GNSS:RTK:BASE<st>:A<ch>:DHEading	400
[:SOURce<hw>]:BB:GNSS:RTK:BASE<st>:A<ch>:DElevation	400
[:SOURce<hw>]:BB:GNSS:RTK:BASE<st>:A<ch>:DX	400
[:SOURce<hw>]:BB:GNSS:RTK:BASE<st>:A<ch>:DY	400
[:SOURce<hw>]:BB:GNSS:RTK:BASE<st>:A<ch>:DZ	400

[[:SOURce<hw>]:BB:GNSS:RTK:BASE<st>:A<ch>:BODY:FILE <BodyMaskFile>

[[:SOURce<hw>]:BB:GNSS:RTK:BASE<st>:A<ch>:APATtern:FILE <Filename>

Loads the selected file from the default or the specified directory. Loaded are files with extension *.ant_pat/*.body_mask.

Parameters:

<Filename>	"<filename>"
	Filename or complete file path; file extension can be omitted.
	Query the existing files with the following commands:
	[:SOURce<hw>]:BB:GNSS:APATtern:CATalog:PREDefined? on page 391
	[:SOURce<hw>]:BB:GNSS:APATtern:CATalog:USER? on page 391

Example:	See Example"Configuring RTK base station location" on page 394.
-----------------	---

Manual operation: See ["Body Mask, Antenna Pattern"](#) on page 128

[:SOURCE<hw>]:BB:GNSS:RTK:BASE<st>:A<ch>:STATE <State>

Activates the antenna.

Parameters:

<State> 1 | ON | 0 | OFF

Example: See [Example"Configuring RTK base station antenna"](#) on page 394.

Manual operation: See ["Active"](#) on page 128

[:SOURCE<hw>]:BB:GNSS:RTK:BASE<st>:A<ch>:DBANK <DeltaBank>

[:SOURCE<hw>]:BB:GNSS:RTK:BASE<st>:A<ch>:DHEADING <DeltaHeading>

[:SOURCE<hw>]:BB:GNSS:RTK:BASE<st>:A<ch>:DELEVATION <DeltaElevation>

Sets orientation and tilt of the antenna of the RTK base station.

The values are relative to the center of gravity (COG).

Parameters:

<DeltaElevation> float
 Range: -180 to 180
 Increment: 0.001
 *RST: 0

Example: See [Example"Configuring RTK base station antenna"](#) on page 394.

[:SOURCE<hw>]:BB:GNSS:RTK:BASE<st>:A<ch>:DX <DeltaX>

[:SOURCE<hw>]:BB:GNSS:RTK:BASE<st>:A<ch>:DY <DeltaY>

[:SOURCE<hw>]:BB:GNSS:RTK:BASE<st>:A<ch>:DZ <DeltaZ>

Sets the antenna position of an RTK base station as an offset on the x, y and z axis.

The offset is relative to center of gravity (COG).

Parameters:

<DeltaZ> float
 Range: -200 to 200
 Increment: 0.001
 *RST: 0

Example: See [Example"Configuring RTK base station antenna"](#) on page 394.

Manual operation: See ["Delta X, Delta Y, Delta Z"](#) on page 129

22.6.4 RTK protocol commands

<code>[:SOURCE<hw>]:BB:GNSS:RTK:PASSWORD?</code>	401
<code>[:SOURCE<hw>]:BB:GNSS:RTK:PORT</code>	401
<code>[:SOURCE<hw>]:BB:GNSS:RTK:PROTOCOL</code>	401
<code>[:SOURCE<hw>]:BB:GNSS:RTK:USER?</code>	401

`[:SOURCE<hw>]:BB:GNSS:RTK:PASSWORD?`

Queries the password, that belongs to the RTCM user name.

Return values:

<Password> string

Example: See [Example "Configuring real-time kinematics \(RTK\) protocol"](#) on page 394.

Usage: Query only

Manual operation: See ["Password"](#) on page 157

`[:SOURCE<hw>]:BB:GNSS:RTK:PORT <PortNumber>`

Sets the port number of the LAN connection.

Parameters:

<PortNumber> 2101 | 4022 | 50000
 *RST: 2101

Example: See [Example "Configuring real-time kinematics \(RTK\) protocol"](#) on page 394.

Manual operation: See ["Port"](#) on page 156

`[:SOURCE<hw>]:BB:GNSS:RTK:PROTOCOL <Protocol>`

Queries the protocol for transmitting RTK data.

Parameters:

<Protocol> RTCM
 NTRIP/RTCM 3.3 protocol
 *RST: RTCM

Example: See [Example "Configuring real-time kinematics \(RTK\) protocol"](#) on page 394.

Manual operation: See ["Protocol"](#) on page 156
 See ["User ID"](#) on page 156

`[:SOURCE<hw>]:BB:GNSS:RTK:USER?`

Queries the user ID, that is the RTCM user name.

Return values:

<UserId> string

Example:

See [Example "Configuring real-time kinematics \(RTK\) protocol"](#) on page 394.

Usage:

Query only

22.7 Environment configuration commands

Option: R&S SMW-K108

Example: Defining a full obscuration environment

```
// Select and enable a full obscuration user defined environment.
SOURCE1:BB:GNSS:RECEIVER:V1:ENVIRONMENT:ENVIRONMENT FULL
SOURCE1:BB:GNSS:RECEIVER:V1:ENVIRONMENT:TYPE USER
SOURCE1:BB:GNSS:RECEIVER:V1:ENVIRONMENT:OBSCURATION

// Define a full obscuration area as a sequence of obscured zones.
SOURCE1:BB:GNSS:RECEIVER:V1:ENVIRONMENT:FULL:SCALE DISTANCE
SOURCE1:BB:GNSS:RECEIVER:V1:ENVIRONMENT:FULL:AREA:COUNT 2
SOURCE1:BB:GNSS:RECEIVER:V1:ENVIRONMENT:FULL:AREA1:REFERENCE 0.5
SOURCE1:BB:GNSS:RECEIVER:V1:ENVIRONMENT:FULL:AREA1:LENGTH 0.1
SOURCE1:BB:GNSS:RECEIVER:V1:ENVIRONMENT:FULL:AREA2:REFERENCE 2.5
SOURCE1:BB:GNSS:RECEIVER:V1:ENVIRONMENT:FULL:AREA2:LENGTH 1
SOURCE1:BB:GNSS:RECEIVER:V1:ENVIRONMENT:FULL:AREA:APPEND
SOURCE1:BB:GNSS:RECEIVER:V1:ENVIRONMENT:FULL:AREA:COUNT?
// Response: 3
SOURCE1:BB:GNSS:RECEIVER:V1:ENVIRONMENT:FULL:AREA3:DELETE
SOURCE1:BB:GNSS:RECEIVER:V1:ENVIRONMENT:FULL:AREA:COUNT?
// Response: 2
SOURCE1:BB:GNSS:RECEIVER:V1:ENVIRONMENT:FULL:AREA1:INSERT
SOURCE1:BB:GNSS:RECEIVER:V1:ENVIRONMENT:FULL:AREA2:REFERENCE 1.5
SOURCE1:BB:GNSS:RECEIVER:V1:ENVIRONMENT:FULL:AREA2:LENGTH 0.5
SOURCE1:BB:GNSS:RECEIVER:V1:ENVIRONMENT:FULL:AREA:COUNT?
// Response: 3

// Define a full obscuration area as a zone pattern.
SOURCE1:BB:GNSS:RECEIVER:V1:ENVIRONMENT:FULL:SCALE TIME
SOURCE1:BB:GNSS:RECEIVER:V1:ENVIRONMENT:FULL:RWINDOW 1000
SOURCE1:BB:GNSS:RECEIVER:V1:ENVIRONMENT:FULL:RWINDOW:STATE ON
// The defined objects are repeated every 1000 seconds.
```

Example: Selecting a vertical obscuration environment

```
// Select and enable a vertical obscuration environment.
SOURCE1:BB:GNSS:RECEIVER:V1:ENVIRONMENT:MODEL VOBS
SOURCE1:BB:GNSS:RECEIVER:V1:ENVIRONMENT:TYPE URB1
SOURCE1:BB:GNSS:RECEIVER:V1:ENVIRONMENT:OMPATH
```

```
// Query available obstacles files and load a file.
SOURCE1:BB:GNSS:RECEIVER:V1:ENVIRONMENT:VOBS:CATALOG:PREDEFINED?
// Response: Urban_Canyon_1
:MMEM:CDIRECTORY "/var/user/my_vobs"
SOURCE1:BB:GNSS:RECEIVER:V1:ENVIRONMENT:VOBS:CATALOG:USER?
// Response: canyon_2
SOURCE1:BB:GNSS:RECEIVER:V1:ENVIRONMENT:VOBS:FILE "/var/user/my_vobs/canyon_2"

// Define the receiver position.
SOURCE1:BB:GNSS:RECEIVER:V1:ENVIRONMENT:VOBS:ROFFSET:X 15
SOURCE1:BB:GNSS:RECEIVER:V1:ENVIRONMENT:VOBS:ROFFSET:Y 2
SOURCE1:BB:GNSS:RECEIVER:V1:ENVIRONMENT:VOBS:ROFFSET:HEIGHT 0
// Define map orientation.
SOURCE1:BB:GNSS:RECEIVER:V1:ENVIRONMENT:VOBS:MORIENTATION 90
// x-axis points to north direction, y-axis points to west direction
```

Example: Defining roadside planes

```
// Select and enable a roadside planes environment.
SOURCE1:BB:GNSS:RECEIVER:V1:ENVIRONMENT:MODEL RPL
```

Example: Defining a user-defined ground and sea reflection

```
SOURCE1:BB:GNSS:SMODE AUTO
SOURCE1:BB:GNSS:VEHICLE:TYPE AIRCRAFT
// Select and enable a ground and sea reflection environment.
SOURCE1:BB:GNSS:RECEIVER:V1:ENVIRONMENT:ENVIRONMENT GSR
SOURCE1:BB:GNSS:RECEIVER:V1:ENVIRONMENT:TYPE USER
SOURCE1:BB:GNSS:RECEIVER:V1:ENVIRONMENT:OMPATH

// Define material property parameters.
SOURCE1:BB:GNSS:RECEIVER:V1:ENVIRONMENT:GSP:STYPE USER
SOURCE1:BB:GNSS:RECEIVER:V1:ENVIRONMENT:GSP:MPROPERTY PERM
SOURCE1:BB:GNSS:RECEIVER:V1:ENVIRONMENT:GSP:PERMITTIVITY 10
SOURCE1:BB:GNSS:RECEIVER:V1:ENVIRONMENT:GSP:CONDUCTIVITY 1
// Define obstacles and the distance between ground and obstacle.
SOURCE1:BB:GNSS:RECEIVER:V1:ENVIRONMENT:GSP:GALTITUDE 0
SOURCE1:BB:GNSS:RECEIVER:V1:ENVIRONMENT:GSP:O1HEIGHT 500
SOURCE1:BB:GNSS:RECEIVER:V1:ENVIRONMENT:GSP:O2HEIGHT 1000
SOURCE1:BB:GNSS:RECEIVER:V1:ENVIRONMENT:GSP:O1DISTANCE 1000
SOURCE1:BB:GNSS:RECEIVER:V1:ENVIRONMENT:GSP:O2DISTANCE 1000
```

Commands:

[:SOURCE<hw>]:BB:GNSS:RECEIVER[V<st>]:ENVIRONMENT:RPL:PMODEL.....	404
[:SOURCE<hw>]:BB:GNSS:RECEIVER[V<st>]:ENVIRONMENT:VOBS:PMODEL.....	404
[:SOURCE<hw>]:BB:GNSS:RECEIVER[V<st>]:ENVIRONMENT:PMODEL.....	404
[:SOURCE<hw>]:BB:GNSS:RECEIVER[V<st>]:ENVIRONMENT:VOBS:ROFFSET:X.....	405
[:SOURCE<hw>]:BB:GNSS:RECEIVER[V<st>]:ENVIRONMENT:VOBS:ROFFSET:Y.....	405
[:SOURCE<hw>]:BB:GNSS:RECEIVER[V<st>]:ENVIRONMENT:VOBS:ROFFSET:HEIGHT.....	405
[:SOURCE<hw>]:BB:GNSS:RECEIVER[V<st>]:ENVIRONMENT:VOBS:MORIENTATION.....	406
[:SOURCE<hw>]:BB:GNSS:RECEIVER[V<st>]:ENVIRONMENT:PREDEFINED.....	406

Environment configuration commands

<code>[:SOURce<hw>]:BB:GNSS:RECeiver[:V<st>]:ENVironment:FULL:PREDefined</code>	406
<code>[:SOURce<hw>]:BB:GNSS:RECeiver[:V<st>]:ENVironment:RPL:PREDefined</code>	406
<code>[:SOURce<hw>]:BB:GNSS:RECeiver[:V<st>]:ENVironment:VOBS:PREDefined</code>	406
<code>[:SOURce<hw>]:BB:GNSS:OBSCuration:LMM:CATalog:PREDefined?</code>	407
<code>[:SOURce<hw>]:BB:GNSS:OBSCuration:RPL:CATalog:PREDefined?</code>	407
<code>[:SOURce<hw>]:BB:GNSS:OBSCuration:VOBS:CATalog:PREDefined?</code>	407
<code>[:SOURce<hw>]:BB:GNSS:OBSCuration:LMM:CATalog:USER?</code>	407
<code>[:SOURce<hw>]:BB:GNSS:OBSCuration:RPL:CATalog:USER?</code>	407
<code>[:SOURce<hw>]:BB:GNSS:OBSCuration:VOBS:CATalog:USER?</code>	407
<code>[:SOURce<hw>]:BB:GNSS:RECeiver[:V<st>]:ENVironment:LMM:FILE</code>	407
<code>[:SOURce<hw>]:BB:GNSS:RECeiver[:V<st>]:ENVironment:RPL:FILE</code>	407
<code>[:SOURce<hw>]:BB:GNSS:RECeiver[:V<st>]:ENVironment:VOBS:FILE</code>	407
<code>[:SOURce<hw>]:BB:GNSS:RECeiver[:V<st>]:ENVironment:RPL:ROFFset:HEIGHt</code>	408
<code>[:SOURce<hw>]:BB:GNSS:RECeiver[:V<st>]:ENVironment:RPL:RWINDow</code>	408
<code>[:SOURce<hw>]:BB:GNSS:RECeiver[:V<st>]:ENVironment:RPL:RWINDow:STATe</code>	408
<code>[:SOURce<hw>]:BB:GNSS:RECeiver[:V<st>]:ENVironment:RPL:RWINDow:STRajectory</code>	409
<code>[:SOURce<hw>]:BB:GNSS:RECeiver[:V<st>]:ENVironment:RPL:DISPLay</code>	409
<code>[:SOURce<hw>]:BB:GNSS:RECeiver[:V<st>]:ENVironment:RPL:ILENght</code>	409
<code>[:SOURce<hw>]:BB:GNSS:RECeiver[:V<st>]:ENVironment:FULL:SCALE</code>	409
<code>[:SOURce<hw>]:BB:GNSS:RECeiver[:V<st>]:ENVironment:FULL:RWINDow</code>	410
<code>[:SOURce<hw>]:BB:GNSS:RECeiver[:V<st>]:ENVironment:FULL:RWINDow:STATe</code>	410
<code>[:SOURce<hw>]:BB:GNSS:RECeiver[:V<st>]:ENVironment:FULL:RWINDow:STRajectory</code>	410
<code>[:SOURce<hw>]:BB:GNSS:RECeiver[:V<st>]:ENVironment:FULL:AREA:COUNT?</code>	410
<code>[:SOURce<hw>]:BB:GNSS:RECeiver[:V<st>]:ENVironment:FULL:AREA:APPend</code>	411
<code>[:SOURce<hw>]:BB:GNSS:RECeiver[:V<st>]:ENVironment:FULL:AREA<ch>:INSert</code>	411
<code>[:SOURce<hw>]:BB:GNSS:RECeiver[:V<st>]:ENVironment:FULL:AREA<ch>:DELeTe</code>	411
<code>[:SOURce<hw>]:BB:GNSS:RECeiver[:V<st>]:ENVironment:FULL:AREA<ch>:REFerence</code>	411
<code>[:SOURce<hw>]:BB:GNSS:RECeiver[:V<st>]:ENVironment:FULL:AREA<ch>:LENGTh</code>	411
<code>[:SOURce<hw>]:BB:GNSS:RECeiver[:V<st>]:ENVironment:GSR:MPROperty</code>	412
<code>[:SOURce<hw>]:BB:GNSS:RECeiver[:V<st>]:ENVironment:GSR:STYPe</code>	412
<code>[:SOURce<hw>]:BB:GNSS:RECeiver[:V<st>]:ENVironment:GSR:PERMittivity</code>	412
<code>[:SOURce<hw>]:BB:GNSS:RECeiver[:V<st>]:ENVironment:GSR:CONDuctivity</code>	413
<code>[:SOURce<hw>]:BB:GNSS:RECeiver[:V<st>]:ENVironment:GSR:PLOSSs</code>	413
<code>[:SOURce<hw>]:BB:GNSS:RECeiver[:V<st>]:ENVironment:GSR:O1Distance</code>	413
<code>[:SOURce<hw>]:BB:GNSS:RECeiver[:V<st>]:ENVironment:GSR:O2Distance</code>	413
<code>[:SOURce<hw>]:BB:GNSS:RECeiver[:V<st>]:ENVironment:GSR:O1Height</code>	414
<code>[:SOURce<hw>]:BB:GNSS:RECeiver[:V<st>]:ENVironment:GSR:O2Height</code>	414
<code>[:SOURce<hw>]:BB:GNSS:RECeiver[:V<st>]:ENVironment:GSR:GALTitude</code>	414
<code>[:SOURce<hw>]:BB:GNSS:RECeiver[:V<st>]:ENVironment:GSR:OORientation</code>	414

`[:SOURce<hw>]:BB:GNSS:RECeiver[:V<st>]:ENVironment:RPL:PMODEl <Model>`

`[:SOURce<hw>]:BB:GNSS:RECeiver[:V<st>]:ENVironment:VOBS:PMODEl
<Model>`

`[:SOURce<hw>]:BB:GNSS:RECeiver[:V<st>]:ENVironment:PMODEl
<PhysicalModel>`

Selects the physical effects to be simulated on the GNSS signal.

Parameters:

<PhysicalModel> OBSCuration | OMPath

OBSCuration

Simulates obscuration effects.

OMPath

Simulates obscuration and multipath propagation effects.

*RST: OBSCuration

Example: See [Example"Selecting a vertical obscuration environment"](#) on page 402.

Manual operation: See ["Physical Model"](#) on page 135

[:SOURCE<hw>]:BB:GNSS:RECEIVER[:V<st>]:ENVIRONMENT:VOBS:ROFFset:X
 <XOffset>

Sets the initial X position of a receiver relative to the reference point that is the (0, 0, 0) coordinate.

Parameters:

<XOffset> float
 Range: -1500 to 1500
 Increment: 0.1
 *RST: 0

Example: See [Example"Selecting a vertical obscuration environment"](#) on page 402.

Manual operation: See ["Receiver Offset"](#) on page 137

[:SOURCE<hw>]:BB:GNSS:RECEIVER[:V<st>]:ENVIRONMENT:VOBS:ROFFset:Y
 <YOffset>

Sets the initial Y position of a receiver relative to the reference point that is the (0, 0, 0) coordinate.

Parameters:

<YOffset> float
 Range: -1500 to 1500
 Increment: 0.1
 *RST: 0

Example: See [Example"Selecting a vertical obscuration environment"](#) on page 402.

[:SOURCE<hw>]:BB:GNSS:RECEIVER[:V<st>]:ENVIRONMENT:VOBS:ROFFset:
HEIGHT <HeightOffset>

Sets the initial height position (Z) of a receiver relative to the reference point that is the (0, 0, 0) coordinate.

Parameters:

<HeightOffset> float
 Range: 0 to 500
 Increment: 0.1
 *RST: 0

Example: See [Example"Selecting a vertical obscuration environment"](#) on page 402.

Manual operation: See ["Receiver Offset"](#) on page 137

[:SOURCE<hw>]:BB:GNSS:RECEIVER[V<st>]:ENVIRONMENT:VOBS:MORIENTATION
 <MapOrientation>

Defines the map orientation of obstacles relative to the west-east axis.

Parameters:

<MapOrientation> float
 Range: 0 to 359.99
 Increment: 0.01
 *RST: 0

Example: See [Example"Selecting a vertical obscuration environment"](#) on page 402.

Manual operation: See ["Map Orientation"](#) on page 137

[:SOURCE<hw>]:BB:GNSS:RECEIVER[V<st>]:ENVIRONMENT:PREDEFINED <Type>
[:SOURCE<hw>]:BB:GNSS:RECEIVER[V<st>]:ENVIRONMENT:FULL:PREDEFINED
 <PredefinedEnv>

[:SOURCE<hw>]:BB:GNSS:RECEIVER[V<st>]:ENVIRONMENT:RPL:PREDEFINED
 <PredefinedEnv>

[:SOURCE<hw>]:BB:GNSS:RECEIVER[V<st>]:ENVIRONMENT:VOBS:PREDEFINED
 <PredefinedEnv>

Loads a predefined environment configuration.

You can load a user-defined setting or a predefined settings that simulate two urban canyon environments.

Parameters:

<PredefinedEnv> USER | URB1 | URB2
USER
 User-defined environment configuration
URB1|URB2
 Urban canyon environment configuration
 *RST: URB2

Example: See [Example"Selecting a vertical obscuration environment"](#) on page 402.

Manual operation: See ["Predefined Environment"](#) on page 135
See ["Predefined Environment"](#) on page 139

```
[:SOURce<hw>]:BB:GNSS:OBSCuration:LMM:CATalog:PREDefined?
[:SOURce<hw>]:BB:GNSS:OBSCuration:RPL:CATalog:PREDefined?
[:SOURce<hw>]:BB:GNSS:OBSCuration:VOBS:CATalog:PREDefined?
```

Queries the names of predefined files in the system directory.

Listed are only the following file types:

- Obstacles description files (*.rs_obst)
- Roadside buildings description files (*.rs_buil)
- Land mobile multipath (LMM) files (*.lmm)

Example: See [Example"Selecting a vertical obscuration environment"](#) on page 402.

Usage: Query only

Manual operation: See ["Obstacles File"](#) on page 135

```
[:SOURce<hw>]:BB:GNSS:OBSCuration:LMM:CATalog:USER?
[:SOURce<hw>]:BB:GNSS:OBSCuration:RPL:CATalog:USER?
[:SOURce<hw>]:BB:GNSS:OBSCuration:VOBS:CATalog:USER?
```

Queries the names of the user-defined files in the default directory. The default directory is set using command :MME:CDIRectory.

Listed are the following file types:

- Obstacles description files (*.rs_obst)
- Roadside buildings description files (*.rs_buil)
- Land mobile multipath (LMM) files (*.lmm)

Example: See [Example"Selecting a vertical obscuration environment"](#) on page 402.

Usage: Query only

Manual operation: See ["Obstacles File"](#) on page 135

```
[:SOURce<hw>]:BB:GNSS:RECeiver[V<st>]:ENVironment:LMM:FILE <Filename>
[:SOURce<hw>]:BB:GNSS:RECeiver[V<st>]:ENVironment:RPL:FILE <Filename>
[:SOURce<hw>]:BB:GNSS:RECeiver[V<st>]:ENVironment:VOBS:FILE
<Filename>
```

Loads the selected file.

Loaded are only obstacles description files (*.rs_obst) or roadside buildings description files (*.rs_buil).

Loaded are only the following files types:

- Obstacles description files (*.rs_obst)

- Roadside buildings description files (*.rs_buil)
- Land mobile multipath (LMM) files (*.lmm)

Parameters:

<Filename> string

Example: See [Example "Selecting a vertical obscuration environment"](#) on page 402.

Manual operation: See ["Obstacles File"](#) on page 135

[:SOURCE<hw>]:BB:GNSS:RECEIVER[:V<st>]:ENVIRONMENT:RPL:ROFFSET:HEIGHT
<Height>

Sets the receiver height offset, i.e. the antenna altitude relative to the ground.

Parameters:

<Height> float
 Range: 0 to 500
 Increment: 0.1
 *RST: 0

Example: See [Example "Defining roadside planes"](#) on page 403.

Manual operation: See ["Receiver Height Offset"](#) on page 143

[:SOURCE<hw>]:BB:GNSS:RECEIVER[:V<st>]:ENVIRONMENT:RPL:RWINDOW
<RepWindow>

Sets the repetition window. This window defines the distance of repeated obstacles that means contiguous objects.

Parameters:

<RepWindow> integer
 Range: 1 to 1E6
 *RST: 10E3
 Default unit: m

Example: See [Example "Defining roadside planes"](#) on page 403.

Manual operation: See ["Repetition"](#) on page 142

[:SOURCE<hw>]:BB:GNSS:RECEIVER[:V<st>]:ENVIRONMENT:RPL:RWINDOW:STATE
<State>

Enables the repetition of the defined objects.

Parameters:

<State> 1 | ON | 0 | OFF
 *RST: OFF

Example: See [Example "Defining roadside planes"](#) on page 403.

Manual operation: See ["Repetition State"](#) on page 142

[:SOURce<hw>]:BB:GNSS:RECeiver[:V<st>]:ENVironment:RPL:RWINdow:STRajectory

Sets the length of the repetition interval equal to trajectory length of the waypoint file.

Aligning both lengths is useful to ensure that the obscuration pattern repeats itself at each repetition of the waypoint file.

Example: See [Example "Defining roadside planes"](#) on page 403.

Usage: Event

Manual operation: See ["Set To Trajectory Length"](#) on page 142

[:SOURce<hw>]:BB:GNSS:RECeiver[:V<st>]:ENVironment:RPL:DISPLay<Display>

Switches between available views.

Parameters:

<Display> DISTance | HEIGht

DISTance

Distance versus position view

HEIGht

Height versus position view

*RST: HEIGht

Example: See [Example "Defining roadside planes"](#) on page 403.

[:SOURce<hw>]:BB:GNSS:RECeiver[:V<st>]:ENVironment:RPL:ILENgtH <State>

If enabled, assumes roadside planes with infinite width.

Parameters:

<State> 1 | ON | 0 | OFF

*RST: ON

Example: See [Example "Defining roadside planes"](#) on page 403.

Manual operation: See ["Set Length to Infinite"](#) on page 143

[:SOURce<hw>]:BB:GNSS:RECeiver[:V<st>]:ENVironment:FULL:SCALE<ReferenceScale>

Defines whether the obstacles' positions are defined as distance (in km) or as time (in s).

Parameters:

<ReferenceScale> TIME | DISTance

*RST: DIST

Example: See [Example"Defining a full obscuration environment"](#) on page 402.

Manual operation: See ["Reference Scale"](#) on page 145

[:SOURCE<hw>]:BB:GNSS:RECEIVER[:V<st>]:ENVIRONMENT:FULL:RWINDOW
 <RepWindow>

Sets the repeating period (in km or s) of repeating objects.

Parameters:

<RepWindow> integer
 Range: 0 to 1000
 *RST: 10

Example: See [Example"Defining a full obscuration environment"](#) on page 402.

Manual operation: See ["Repetition"](#) on page 145

[:SOURCE<hw>]:BB:GNSS:RECEIVER[:V<st>]:ENVIRONMENT:FULL:RWINDOW:
STATE <State>

Enables the repetition of the defined objects.

Parameters:

<State> 1 | ON | 0 | OFF
 *RST: OFF

Example: See [Example"Defining a full obscuration environment"](#) on page 402.

Manual operation: See ["State"](#) on page 145

[:SOURCE<hw>]:BB:GNSS:RECEIVER[:V<st>]:ENVIRONMENT:FULL:RWINDOW:
TRAJECTORY

Sets the length of the repetition interval equal to trajectory length of the waypoint file.

Aligning both lengths is useful to ensure that the obscuration pattern repeats itself at each repetition of the waypoint file.

Example: See [Example"Defining a full obscuration environment"](#) on page 402.

Usage: Event

Manual operation: See ["Set To Trajectory Length"](#) on page 145

[:SOURCE<hw>]:BB:GNSS:RECEIVER[:V<st>]:ENVIRONMENT:FULL:AREA:COUNT?

Sets the number of the obscured area/zones.

Return values:

<AreasCount> integer
 Range: 0 to 50
 *RST: 0

Example: See [Example"Defining a full obscuration environment"](#) on page 402.

Usage: Query only

Manual operation: See "[Obscured Areas](#)" on page 145

```
[:SOURce<hw>]:BB:GNSS:RECEiver[:V<st>]:ENVIRONMENT:FULL:AREA:APPend
[:SOURce<hw>]:BB:GNSS:RECEiver[:V<st>]:ENVIRONMENT:FULL:AREA<ch>:
  INSert
[:SOURce<hw>]:BB:GNSS:RECEiver[:V<st>]:ENVIRONMENT:FULL:AREA<ch>:
  DELete
```

Appends, insertes or deletes an obscured zone.

Example: See [Example"Defining a full obscuration environment"](#) on page 402.

Usage: Event

Manual operation: See "[Insert, Delete](#)" on page 146

```
[:SOURce<hw>]:BB:GNSS:RECEiver[:V<st>]:ENVIRONMENT:FULL:AREA<ch>:
  REFerence <Reference>
```

Defines the reference starting position (in km) or time stamp (in s) of a specific obscured zone.

Parameters:

<Reference> float
 Range: 0 to 1E4
 Increment: 1E-3
 *RST: 0

Example: See [Example"Defining a full obscuration environment"](#) on page 402.

Manual operation: See "[Obscured Areas](#)" on page 145

```
[:SOURce<hw>]:BB:GNSS:RECEiver[:V<st>]:ENVIRONMENT:FULL:AREA<ch>:
  LENGth <Length>
```

Sets the length of the obscuring zone, defined in km or sec.

Parameters:

<Length> float
 Range: 1E-3 to 50
 Increment: 1E-3
 *RST: 0.1

Example: See [Example"Defining a full obscuration environment"](#) on page 402.

Manual operation: See ["Obscured Areas"](#) on page 145

[:SOURCE<hw>]:BB:GNSS:RECEIVER[:V<st>]:ENVIRONMENT:GSR:MPROPERTY
 <MaterialPropert>

Specifies, if the material is defined by its permittivity/conductivity or by its power loss characteristic.

Parameters:

<MaterialPropert> PLOSS | PERM
 *RST: PERM

Example: See [Example"Defining a user-defined ground and sea reflection"](#) on page 403.

Manual operation: See ["Material Property"](#) on page 147

[:SOURCE<hw>]:BB:GNSS:RECEIVER[:V<st>]:ENVIRONMENT:GSR:STYPE
 <SurfaceType>

Defines the type of surface.

Parameters:

<SurfaceType> SEA | WATER | WET | MDRY | DRY | USER
 *RST: USER

Example: See [Example"Defining a user-defined ground and sea reflection"](#) on page 403.

Manual operation: See ["Surface Type"](#) on page 147

[:SOURCE<hw>]:BB:GNSS:RECEIVER[:V<st>]:ENVIRONMENT:GSR:PERMITTIVITY
 <Permittivity>

Sets the surface permittivity.

Parameters:

<Permittivity> float
 Range: 1 to 100
 Increment: 0.1
 *RST: 10

Example: See [Example"Defining a user-defined ground and sea reflection"](#) on page 403.

Manual operation: See ["Ground Permittivity/Conductivity, Power Loss"](#) on page 148

[:SOURce<hw>]:BB:GNSS:RECeiver[:V<st>]:ENVironment:GSR:CONductivity
<Conductivity>

Sets the surface conductivity.

Parameters:

<Conductivity> float
 Range: 1E-6 to 20
 Increment: 1E-6
 *RST: 1

Example: See [Example"Defining a user-defined ground and sea reflection"](#) on page 403.

Manual operation: See ["Ground Permittivity/Conductivity, Power Loss"](#) on page 148

[:SOURce<hw>]:BB:GNSS:RECeiver[:V<st>]:ENVironment:GSR:PLOs
<PowerLoss>

Sets the surface power loss.

Parameters:

<PowerLoss> integer
 Range: 0 to 20
 *RST: 5

Example: See [Example"Defining a user-defined ground and sea reflection"](#) on page 403.

Manual operation: See ["Ground Permittivity/Conductivity, Power Loss"](#) on page 148

[:SOURce<hw>]:BB:GNSS:RECeiver[:V<st>]:ENVironment:GSR:O1Distance
<Distance>

[:SOURce<hw>]:BB:GNSS:RECeiver[:V<st>]:ENVironment:GSR:O2Distance
<Distance>

Sets the distance between the receiver and the left/right obstacles.

Parameters:

<Distance> float
 Range: 0 to 1E4
 Increment: 0.1
 *RST: 1000

Example: See [Example"Defining a user-defined ground and sea reflection"](#) on page 403.

Manual operation: See ["h1/h2, d1/d2"](#) on page 148

```
[:SOURce<hw>]:BB:GNSS:RECeiver[:V<st>]:ENVironment:GSR:O1Height
<Height>
```

```
[:SOURce<hw>]:BB:GNSS:RECeiver[:V<st>]:ENVironment:GSR:O2Height
<Height>
```

Determines the height of the left/right obstacle.

Parameters:

```
<Height>          float
                   Range:    0 to 10000
                   Increment: 0.1
                   *RST:     100
```

Example: See [Example"Defining a user-defined ground and sea reflection"](#) on page 403.

Manual operation: See "[h1/h2, d1/d2](#)" on page 148

```
[:SOURce<hw>]:BB:GNSS:RECeiver[:V<st>]:ENVironment:GSR:GALTitide
<GroundAltitude>
```

Sets the altitude of the receiver according to the WGS84 geodetic system.

Parameters:

```
<GroundAltitude> float
                   Range:    0 to 10000
                   Increment: 0.1
                   *RST:     0
```

Example: See [Example"Defining a user-defined ground and sea reflection"](#) on page 403.

Manual operation: See "[Ground Altitude](#)" on page 148

```
[:SOURce<hw>]:BB:GNSS:RECeiver[:V<st>]:ENVironment:GSR:OORientation
<Orientation>
```

Sets the obstacle orientation.

Parameters:

```
<Orientation>    float
                   Range:    0 to 359.99
                   Increment: 0.01
                   *RST:     0
```

Example: See [Example"Defining a user-defined ground and sea reflection"](#) on page 403.

22.8 Static multipath configuration

Option: R&S SMW-K108

Example: Enabling static multipath effects

```
// Enable a satellite constellation with GPS and Galileo satellites.
SOURCE1:BB:GNSS:SYSTEM:GPS:STATE 1
SOURCE1:BB:GNSS:SYSTEM:GALILEO:STATE 1

// Enable static multipath.
SOURCE1:BB:GNSS:RECEIVER:V1:ENVIRONMENT:MODEL MPAT
// Select SVIDs and GNSS system.
SOURCE1:BB:GNSS:RECEIVER:V1:ENVIRONMENT:MPATH:SYSTEM GPS
SOURCE1:BB:GNSS:RECEIVER:V1:ENVIRONMENT:MPATH:SVID 1
// Enable line-of-sight (LOS) and one echo.
SOURCE1:BB:GNSS:SVID1:GPS:MPATH:V1:A1:LOS:ENABLE 1
SOURCE1:BB:GNSS:SVID1:GPS:MPATH:V1:A1:ECHOS:COUNT 1
SOURCE1:BB:GNSS:SVID1:GPS:MPATH:V1:A1:ECHO1:ICPHASE 100
SOURCE1:BB:GNSS:SVID1:GPS:MPATH:V1:A1:ECHO1:CPDRIFT 5.3
SOURCE1:BB:GNSS:SVID1:GPS:MPATH:V1:A1:ECHO1:POWER -5
SOURCE1:BB:GNSS:SVID1:GPS:MPATH:V1:A1:ECHO1:CPHASE 3.14
SOURCE1:BB:GNSS:SVID1:GPS:MPATH:V1:A1:ECHO1:DSHIFT 1
// Set automatically based on the Doppler shift
SOURCE1:BB:GNSS:SVID1:GPS:MPATH:V1:A1:ECHO1:CPDRIFT 5.25503546857073
SOURCE1:BB:GNSS:SVID1:GPS:MPATH:V1:A1:ECHO1:AELEVATION 1.5
SOURCE1:BB:GNSS:SVID1:GPS:MPATH:V1:A1:ECHO1:AAZIMUTH 1
// Query LOS parameters.
SOURCE1:BB:GNSS:SVID1:GPS:MPATH:V1:A1:LOS:ICPHASE?
SOURCE1:BB:GNSS:SVID1:GPS:MPATH:V1:A1:LOS:CPDRIFT?
SOURCE1:BB:GNSS:SVID1:GPS:MPATH:V1:A1:LOS:POWER?
SOURCE1:BB:GNSS:SVID1:GPS:MPATH:V1:A1:LOS:CPHASE?
SOURCE1:BB:GNSS:SVID1:GPS:MPATH:V1:A1:LOS:DSHIFT?
SOURCE1:BB:GNSS:SVID1:GPS:MPATH:V1:A1:LOS:AELEVATION?
SOURCE1:BB:GNSS:SVID1:GPS:MPATH:V1:A1:LOS:AAZIMUTH?
// Apply the same configuration to GPS SVID 5.
SOURCE1:BB:GNSS:RECEIVER:V1:ENVIRONMENT:MPATH:COPY:SYSTEM GPS
SOURCE1:BB:GNSS:RECEIVER:V1:ENVIRONMENT:MPATH:COPY:SVID 5
SOURCE1:BB:GNSS:RECEIVER:V1:ENVIRONMENT:MPATH:COPY:EXECUTE
```

Commands:

[:SOURCE<hw>]:BB:GNSS:RECEIVER[V<st>]:ENVIRONMENT[:MODEL].....	418
[:SOURCE<hw>]:BB:GNSS:RECEIVER[V<st>]:ENVIRONMENT:MPATH:SYSTEM.....	419
[:SOURCE<hw>]:BB:GNSS:RECEIVER[V<st>]:ENVIRONMENT:MPATH:SVID.....	419
[:SOURCE<hw>]:BB:GNSS:RECEIVER[V<st>]:ENVIRONMENT:MPATH:COPY:SYSTEM.....	420
[:SOURCE<hw>]:BB:GNSS:RECEIVER[V<st>]:ENVIRONMENT:MPATH:COPY:SVID.....	420
[:SOURCE<hw>]:BB:GNSS:RECEIVER[V<st>]:ENVIRONMENT:MPATH:COPY:EXECUTE.....	421
[:SOURCE<hw>]:BB:GNSS:SVID<ch>:BEIDOU:MPATH[V<us>:A<gr>]:LOS:ENABLE.....	421
[:SOURCE<hw>]:BB:GNSS:SVID<ch>:GALILEO:MPATH[V<us>:A<gr>]:LOS:ENABLE.....	421

Static multipath configuration

[SOURce<hw>]:BB:GNSS:SVID<ch>:GLONass:MPATH[V<us>:A<gr>]:LOS:ENABLE.....	421
[SOURce<hw>]:BB:GNSS:SVID<ch>:QZSS:MPATH[V<us>:A<gr>]:LOS:ENABLE.....	421
[SOURce<hw>]:BB:GNSS:SVID<ch>:NAVic:MPATH[V<us>:A<gr>]:LOS:ENABLE.....	421
[SOURce<hw>]:BB:GNSS:SVID<ch>:SBAS:MPATH[V<us>:A<gr>]:LOS:ENABLE.....	421
[SOURce<hw>]:BB:GNSS:SVID<ch>:GPS:MPATH[V<us>:A<gr>]:LOS:ENABLE.....	421
[SOURce<hw>]:BB:GNSS:SVID<ch>:BEIDou:MPATH[V<us>:A<gr>]:ECHos:COUNT.....	422
[SOURce<hw>]:BB:GNSS:SVID<ch>:GALileo:MPATH[V<us>:A<gr>]:ECHos:COUNT.....	422
[SOURce<hw>]:BB:GNSS:SVID<ch>:GLONass:MPATH[V<us>:A<gr>]:ECHos:COUNT.....	422
[SOURce<hw>]:BB:GNSS:SVID<ch>:QZSS:MPATH[V<us>:A<gr>]:ECHos:COUNT.....	422
[SOURce<hw>]:BB:GNSS:SVID<ch>:NAVic:MPATH[V<us>:A<gr>]:ECHos:COUNT.....	422
[SOURce<hw>]:BB:GNSS:SVID<ch>:SBAS:MPATH[V<us>:A<gr>]:ECHos:COUNT.....	422
[SOURce<hw>]:BB:GNSS:SVID<ch>:GPS:MPATH[V<us>:A<gr>]:ECHos:COUNT.....	422
[SOURce<hw>]:BB:GNSS:SVID<ch>:GPS:MPATH[V<us>:A<gr>]:LOS:ICPHase?.....	422
[SOURce<hw>]:BB:GNSS:SVID<ch>:BEIDou:MPATH[V<us>:A<gr>]:LOS:ICPHase?.....	422
[SOURce<hw>]:BB:GNSS:SVID<ch>:BEIDou:MPATH[V<us>:A<gr>]:ECHO<s2us0>: ICPHase.....	422
[SOURce<hw>]:BB:GNSS:SVID<ch>:GALileo:MPATH[V<us>:A<gr>]:LOS:ICPHase?.....	422
[SOURce<hw>]:BB:GNSS:SVID<ch>:GALileo:MPATH[V<us>:A<gr>]:ECHO<s2us0>: ICPHase.....	422
[SOURce<hw>]:BB:GNSS:SVID<ch>:GLONass:MPATH[V<us>:A<gr>]:LOS:ICPHase?.....	422
[SOURce<hw>]:BB:GNSS:SVID<ch>:GLONass:MPATH[V<us>:A<gr>]:ECHO<s2us0>: ICPHase.....	422
[SOURce<hw>]:BB:GNSS:SVID<ch>:QZSS:MPATH[V<us>:A<gr>]:LOS:ICPHase?.....	422
[SOURce<hw>]:BB:GNSS:SVID<ch>:QZSS:MPATH[V<us>:A<gr>]:ECHO<s2us0>: ICPHase.....	422
[SOURce<hw>]:BB:GNSS:SVID<ch>:NAVic:MPATH[V<us>:A<gr>]:LOS:ICPHase?.....	422
[SOURce<hw>]:BB:GNSS:SVID<ch>:NAVic:MPATH[V<us>:A<gr>]:ECHO<s2us0>: ICPHase.....	422
[SOURce<hw>]:BB:GNSS:SVID<ch>:SBAS:MPATH[V<us>:A<gr>]:LOS:ICPHase?.....	422
[SOURce<hw>]:BB:GNSS:SVID<ch>:SBAS:MPATH[V<us>:A<gr>]:ECHO<s2us0>: ICPHase.....	423
[SOURce<hw>]:BB:GNSS:SVID<ch>:GPS:MPATH[V<us>:A<gr>]:ECHO<s2us0>:ICPHase.....	423
[SOURce<hw>]:BB:GNSS:SVID<ch>:BEIDou:MPATH[V<us>:A<gr>]:LOS:CPDRift?.....	423
[SOURce<hw>]:BB:GNSS:SVID<ch>:BEIDou:MPATH[V<us>:A<gr>]:ECHO<s2us0>: CPDRift.....	423
[SOURce<hw>]:BB:GNSS:SVID<ch>:GALileo:MPATH[V<us>:A<gr>]:LOS:CPDRift?.....	423
[SOURce<hw>]:BB:GNSS:SVID<ch>:GALileo:MPATH[V<us>:A<gr>]:ECHO<s2us0>: CPDRift.....	423
[SOURce<hw>]:BB:GNSS:SVID<ch>:GLONass:MPATH[V<us>:A<gr>]:LOS:CPDRift?.....	423
[SOURce<hw>]:BB:GNSS:SVID<ch>:GLONass:MPATH[V<us>:A<gr>]:ECHO<s2us0>: CPDRift.....	423
[SOURce<hw>]:BB:GNSS:SVID<ch>:QZSS:MPATH[V<us>:A<gr>]:LOS:CPDRift?.....	423
[SOURce<hw>]:BB:GNSS:SVID<ch>:QZSS:MPATH[V<us>:A<gr>]:ECHO<s2us0>:CPDRift.....	423
[SOURce<hw>]:BB:GNSS:SVID<ch>:NAVic:MPATH[V<us>:A<gr>]:LOS:CPDRift?.....	423
[SOURce<hw>]:BB:GNSS:SVID<ch>:NAVic:MPATH[V<us>:A<gr>]:ECHO<s2us0>:CPDRift.....	423
[SOURce<hw>]:BB:GNSS:SVID<ch>:SBAS:MPATH[V<us>:A<gr>]:LOS:CPDRift?.....	423
[SOURce<hw>]:BB:GNSS:SVID<ch>:SBAS:MPATH[V<us>:A<gr>]:ECHO<s2us0>:CPDRift.....	423
[SOURce<hw>]:BB:GNSS:SVID<ch>:GPS:MPATH[V<us>:A<gr>]:LOS:CPDRift?.....	423
[SOURce<hw>]:BB:GNSS:SVID<ch>:GPS:MPATH[V<us>:A<gr>]:ECHO<s2us0>:CPDRift.....	423
[SOURce<hw>]:BB:GNSS:SVID<ch>:BEIDou:MPATH[V<us>:A<gr>]:LOS:POWER?.....	424

Static multipath configuration

[:SOURce<hw>]:BB:GNSS:SVID<ch>:BEIDou:MPATH[:V<us>:A<gr>]:ECHO<s2us0>: POWER.....	424
[:SOURce<hw>]:BB:GNSS:SVID<ch>:GALileo:MPATH[:V<us>:A<gr>]:LOS:POWER?.....	424
[:SOURce<hw>]:BB:GNSS:SVID<ch>:GALileo:MPATH[:V<us>:A<gr>]:ECHO<s2us0>: POWER.....	424
[:SOURce<hw>]:BB:GNSS:SVID<ch>:GLONass:MPATH[:V<us>:A<gr>]:LOS:POWER?.....	424
[:SOURce<hw>]:BB:GNSS:SVID<ch>:GLONass:MPATH[:V<us>:A<gr>]:ECHO<s2us0>: POWER.....	424
[:SOURce<hw>]:BB:GNSS:SVID<ch>:QZSS:MPATH[:V<us>:A<gr>]:LOS:POWER?.....	424
[:SOURce<hw>]:BB:GNSS:SVID<ch>:QZSS:MPATH[:V<us>:A<gr>]:ECHO<s2us0>:POWER.	424
[:SOURce<hw>]:BB:GNSS:SVID<ch>:NAVic:MPATH[:V<us>:A<gr>]:LOS:POWER?.....	424
[:SOURce<hw>]:BB:GNSS:SVID<ch>:NAVic:MPATH[:V<us>:A<gr>]:ECHO<s2us0>:POWER.	424
[:SOURce<hw>]:BB:GNSS:SVID<ch>:SBAS:MPATH[:V<us>:A<gr>]:LOS:POWER?.....	424
[:SOURce<hw>]:BB:GNSS:SVID<ch>:SBAS:MPATH[:V<us>:A<gr>]:ECHO<s2us0>:POWER.	424
[:SOURce<hw>]:BB:GNSS:SVID<ch>:GPS:MPATH[:V<us>:A<gr>]:LOS:POWER?.....	424
[:SOURce<hw>]:BB:GNSS:SVID<ch>:GPS:MPATH[:V<us>:A<gr>]:ECHO<s2us0>:POWER...	424
[:SOURce<hw>]:BB:GNSS:SVID<ch>:BEIDou:MPATH[:V<us>:A<gr>]:LOS:CPHase?.....	425
[:SOURce<hw>]:BB:GNSS:SVID<ch>:BEIDou:MPATH[:V<us>:A<gr>]:ECHO<s2us0>: CPHase.....	425
[:SOURce<hw>]:BB:GNSS:SVID<ch>:GALileo:MPATH[:V<us>:A<gr>]:LOS:CPHase?.....	425
[:SOURce<hw>]:BB:GNSS:SVID<ch>:GALileo:MPATH[:V<us>:A<gr>]:ECHO<s2us0>: CPHase.....	425
[:SOURce<hw>]:BB:GNSS:SVID<ch>:GLONass:MPATH[:V<us>:A<gr>]:LOS:CPHase?.....	425
[:SOURce<hw>]:BB:GNSS:SVID<ch>:GLONass:MPATH[:V<us>:A<gr>]:ECHO<s2us0>: CPHase.....	425
[:SOURce<hw>]:BB:GNSS:SVID<ch>:QZSS:MPATH[:V<us>:A<gr>]:LOS:CPHase?.....	425
[:SOURce<hw>]:BB:GNSS:SVID<ch>:QZSS:MPATH[:V<us>:A<gr>]:ECHO<s2us0>:CPHase	425
[:SOURce<hw>]:BB:GNSS:SVID<ch>:NAVic:MPATH[:V<us>:A<gr>]:LOS:CPHase?.....	425
[:SOURce<hw>]:BB:GNSS:SVID<ch>:NAVic:MPATH[:V<us>:A<gr>]:ECHO<s2us0>:CPHase	425
[:SOURce<hw>]:BB:GNSS:SVID<ch>:SBAS:MPATH[:V<us>:A<gr>]:LOS:CPHase?.....	425
[:SOURce<hw>]:BB:GNSS:SVID<ch>:SBAS:MPATH[:V<us>:A<gr>]:ECHO<s2us0>:CPHase	425
[:SOURce<hw>]:BB:GNSS:SVID<ch>:GPS:MPATH[:V<us>:A<gr>]:LOS:CPHase?.....	425
[:SOURce<hw>]:BB:GNSS:SVID<ch>:GPS:MPATH[:V<us>:A<gr>]:ECHO<s2us0>:CPHase.	425
[:SOURce<hw>]:BB:GNSS:SVID<ch>:BEIDou:MPATH[:V<us>:A<gr>]:LOS:DSHift?.....	425
[:SOURce<hw>]:BB:GNSS:SVID<ch>:BEIDou:MPATH[:V<us>:A<gr>]:ECHO<s2us0>:DSHift	425
[:SOURce<hw>]:BB:GNSS:SVID<ch>:GALileo:MPATH[:V<us>:A<gr>]:LOS:DSHift?.....	425
[:SOURce<hw>]:BB:GNSS:SVID<ch>:GALileo:MPATH[:V<us>:A<gr>]:ECHO<s2us0>:DSHift	425
[:SOURce<hw>]:BB:GNSS:SVID<ch>:GLONass:MPATH[:V<us>:A<gr>]:LOS:DSHift?.....	425
[:SOURce<hw>]:BB:GNSS:SVID<ch>:GLONass:MPATH[:V<us>:A<gr>]:ECHO<s2us0>: DSHift.....	426
[:SOURce<hw>]:BB:GNSS:SVID<ch>:QZSS:MPATH[:V<us>:A<gr>]:LOS:DSHift?.....	426
[:SOURce<hw>]:BB:GNSS:SVID<ch>:QZSS:MPATH[:V<us>:A<gr>]:ECHO<s2us0>:DSHift..	426
[:SOURce<hw>]:BB:GNSS:SVID<ch>:NAVic:MPATH[:V<us>:A<gr>]:LOS:DSHift?.....	426
[:SOURce<hw>]:BB:GNSS:SVID<ch>:NAVic:MPATH[:V<us>:A<gr>]:ECHO<s2us0>:DSHift..	426
[:SOURce<hw>]:BB:GNSS:SVID<ch>:SBAS:MPATH[:V<us>:A<gr>]:LOS:DSHift?.....	426
[:SOURce<hw>]:BB:GNSS:SVID<ch>:SBAS:MPATH[:V<us>:A<gr>]:ECHO<s2us0>:DSHift..	426
[:SOURce<hw>]:BB:GNSS:SVID<ch>:GPS:MPATH[:V<us>:A<gr>]:LOS:DSHift?.....	426
[:SOURce<hw>]:BB:GNSS:SVID<ch>:GPS:MPATH[:V<us>:A<gr>]:ECHO<s2us0>:DSHift....	426
[:SOURce<hw>]:BB:GNSS:SVID<ch>:GPS:MPATH[:V<us>:A<gr>]:LOS:AAZimuth?.....	426
[:SOURce<hw>]:BB:GNSS:SVID<ch>:BEIDou:MPATH[:V<us>:A<gr>]:LOS:AAZimuth?.....	426

[SOURce<hw>]:BB:GNSS:SVID<ch>:BEIDou:MPATH[V<us>:A<gr>]:ECHO<s2us0>: AAZimuth.....	426
[SOURce<hw>]:BB:GNSS:SVID<ch>:GALileo:MPATH[V<us>:A<gr>]:LOS:AAZimuth?.....	426
[SOURce<hw>]:BB:GNSS:SVID<ch>:GALileo:MPATH[V<us>:A<gr>]:ECHO<s2us0>: AAZimuth.....	426
[SOURce<hw>]:BB:GNSS:SVID<ch>:GLONass:MPATH[V<us>:A<gr>]:LOS:AAZimuth?.....	426
[SOURce<hw>]:BB:GNSS:SVID<ch>:GLONass:MPATH[V<us>:A<gr>]:ECHO<s2us0>: AAZimuth.....	426
[SOURce<hw>]:BB:GNSS:SVID<ch>:QZSS:MPATH[V<us>:A<gr>]:LOS:AAZimuth?.....	426
[SOURce<hw>]:BB:GNSS:SVID<ch>:QZSS:MPATH[V<us>:A<gr>]:ECHO<s2us0>: AAZimuth.....	426
[SOURce<hw>]:BB:GNSS:SVID<ch>:NAVic:MPATH[V<us>:A<gr>]:LOS:AAZimuth?.....	426
[SOURce<hw>]:BB:GNSS:SVID<ch>:NAVic:MPATH[V<us>:A<gr>]:ECHO<s2us0>: AAZimuth.....	426
[SOURce<hw>]:BB:GNSS:SVID<ch>:SBAS:MPATH[V<us>:A<gr>]:LOS:AAZimuth?.....	427
[SOURce<hw>]:BB:GNSS:SVID<ch>:SBAS:MPATH[V<us>:A<gr>]:ECHO<s2us0>: AAZimuth.....	427
[SOURce<hw>]:BB:GNSS:SVID<ch>:GPS:MPATH[V<us>:A<gr>]:ECHO<s2us0>: AAZimuth.....	427
[SOURce<hw>]:BB:GNSS:SVID<ch>:GPS:MPATH[V<us>:A<gr>]:LOS:AELEVation?.....	427
[SOURce<hw>]:BB:GNSS:SVID<ch>:BEIDou:MPATH[V<us>:A<gr>]:LOS:AELEVation?.....	427
[SOURce<hw>]:BB:GNSS:SVID<ch>:BEIDou:MPATH[V<us>:A<gr>]:ECHO<s2us0>: AELEVation.....	427
[SOURce<hw>]:BB:GNSS:SVID<ch>:GALileo:MPATH[V<us>:A<gr>]:LOS:AELEVation?.....	427
[SOURce<hw>]:BB:GNSS:SVID<ch>:GALileo:MPATH[V<us>:A<gr>]:ECHO<s2us0>: AELEVation.....	427
[SOURce<hw>]:BB:GNSS:SVID<ch>:GLONass:MPATH[V<us>:A<gr>]:LOS:AELEVation?..	427
[SOURce<hw>]:BB:GNSS:SVID<ch>:GLONass:MPATH[V<us>:A<gr>]:ECHO<s2us0>: AELEVation.....	427
[SOURce<hw>]:BB:GNSS:SVID<ch>:QZSS:MPATH[V<us>:A<gr>]:LOS:AELEVation?.....	427
[SOURce<hw>]:BB:GNSS:SVID<ch>:QZSS:MPATH[V<us>:A<gr>]:ECHO<s2us0>: AELEVation.....	427
[SOURce<hw>]:BB:GNSS:SVID<ch>:NAVic:MPATH[V<us>:A<gr>]:LOS:AELEVation?.....	427
[SOURce<hw>]:BB:GNSS:SVID<ch>:NAVic:MPATH[V<us>:A<gr>]:ECHO<s2us0>: AELEVation.....	427
[SOURce<hw>]:BB:GNSS:SVID<ch>:SBAS:MPATH[V<us>:A<gr>]:LOS:AELEVation?.....	427
[SOURce<hw>]:BB:GNSS:SVID<ch>:SBAS:MPATH[V<us>:A<gr>]:ECHO<s2us0>: AELEVation.....	427
[SOURce<hw>]:BB:GNSS:SVID<ch>:GPS:MPATH[V<us>:A<gr>]:ECHO<s2us0>: AELEVation.....	427

[SOURce<hw>]:BB:GNSS:RECeiver[V<st>]:ENVIRONMENT[:MODEl]
<Environment>

Sets the environment model.

Parameters:

<Environment> LOS | MPATH
*RST: LOS

Example: See [Example"Enabling static multipath effects"](#) on page 415.

Manual operation: See ["Environment Model"](#) on page 133

```
[:SOURce<hw>]:BB:GNSS:RECEiver[:V<st>]:ENVironment:MPATH:SYSTem
<SystemSource>
```

Sets the GNSS system.

If the copy to function is used, this setting refers to the source.

Parameters:

<SystemSource> GPS | GALileo | GLONass | BEIDou | QZSS | SBAS
 *RST: GPS

Example: See [Example"Enabling static multipath effects"](#) on page 415.

Manual operation: See ["Standard, SV-ID \(source\), Copy To, Standard, SV-ID \(target\)"](#) on page 149

```
[:SOURce<hw>]:BB:GNSS:RECEiver[:V<st>]:ENVironment:MPATH:SVID
<SvIdSource>
```

Sets the SV ID number.

If the copy to function is used, this setting refers to the source.

Parameters:

<SvIdSource> 1 | 2 | 3 | 5 | 4 | 6 | 7 | 8 | 9 | 10 | 11 | 12 | 13 | 14 | 15 | 16 | 17 |
 19 | 18 | 20 | 21 | 22 | 23 | 24 | 25 | 26 | 27 | 28 | 29 | 30 | 31 |
 32 | 33 | 34 | 35 | 36 | 37 | 38 | 39 | 40 | 41 | 42 | 43 | 44 | 45 |
 46 | 47 | 48 | 49 | 50 | 51 | 52 | 53 | 54 | 55 | 56 | 57 | 58 | 59 |
 60 | 61 | 62 | 63 | 64 | 65 | 66 | 67 | 68 | 69 | 70 | 71 | 72 | 73 |
 74 | 75 | 76 | 77 | 78 | 79 | 80 | 81 | 82 | 83 | 84 | 85 | 86 | 87 |
 88 | 89 | 90 | 91 | 92 | 93 | 94 | 95 | 96 | 97 | 98 | 99 | 100 | 101 |
 102 | 103 | 104 | 105 | 106 | 107 | 108 | 109 | 110 | 111 | 112 |
 113 | 114 | 115 | 116 | 117 | 118 | 119 | 120 | 121 | 122 | 123 |
 124 | 125 | 126 | 127 | 128 | 129 | 130 | 131 | 132 | 133 | 134 |
 135 | 136 | 137 | 138 | 139 | 140 | 141 | 142 | 143 | 144 | 145 |
 146 | 147 | 148 | 149 | 150 | 151 | 152 | 153 | 154 | 155 | 156 |
 157 | 158 | 159 | 160 | 161 | 162 | 163 | 164 | 165 | 166 | 167 |
 168 | 169 | 170 | 171 | 172 | 173 | 174 | 175 | 176 | 177 | 178 |
 179 | 180 | 181 | 182 | 183 | 184 | 185 | 186 | 187 | 188 | 189 |
 190 | 191 | 192 | 193 | 194 | 195 | 196 | 197 | 198 | 199 | 200 |
 ALL
 *RST: 1

Example: See [Example"Enabling static multipath effects"](#) on page 415.

Manual operation: See ["Standard, SV-ID \(source\), Copy To, Standard, SV-ID \(target\)"](#) on page 149

```
[ :SOURce<hw>]:BB:GNSS:RECEiver[:V<st>]:ENVironment:MPATH:COPY:
  SYSTEM <SystemSource>
```

Sets the GNSS system.

If the copy to function is used, this setting refers to the target.

Parameters:

```
<SystemSource>  GPS | GALileo | GLONass | BEIDou | QZSS | SBAS
*RST:           GPS
```

Example: See [Example"Enabling static multipath effects"](#) on page 415.

Manual operation: See ["Standard, SV-ID \(source\), Copy To, Standard, SV-ID \(target\)"](#) on page 149

```
[ :SOURce<hw>]:BB:GNSS:RECEiver[:V<st>]:ENVironment:MPATH:COPY:SVID
  <SvIdDestination>
```

Sets the SV ID number.

If the copy to function is used, this setting refers to the target.

Parameters:

```
<SvIdDestination>  1 | 2 | 3 | 5 | 4 | 6 | 7 | 8 | 9 | 10 | 11 | 12 | 13 | 14 | 15 | 16 | 17 |
19 | 18 | 20 | 21 | 22 | 23 | 24 | 25 | 26 | 27 | 28 | 29 | 30 | 31 |
32 | 33 | 34 | 35 | 36 | 37 | 38 | 39 | 40 | 41 | 42 | 43 | 44 | 45 |
46 | 47 | 48 | 49 | 50 | 51 | 52 | 53 | 54 | 55 | 56 | 57 | 58 | 59 |
60 | 61 | 62 | 63 | 64 | 65 | 66 | 67 | 68 | 69 | 70 | 71 | 72 | 73 |
74 | 75 | 76 | 77 | 78 | 79 | 80 | 81 | 82 | 83 | 84 | 85 | 86 | 87 |
88 | 89 | 90 | 91 | 92 | 93 | 94 | 95 | 96 | 97 | 98 | 99 | 100 | 101 |
102 | 103 | 104 | 105 | 106 | 107 | 108 | 109 | 110 | 111 | 112 |
113 | 114 | 115 | 116 | 117 | 118 | 119 | 120 | 121 | 122 | 123 |
124 | 125 | 126 | 127 | 128 | 129 | 130 | 131 | 132 | 133 | 134 |
135 | 136 | 137 | 138 | 139 | 140 | 141 | 142 | 143 | 144 | 145 |
146 | 147 | 148 | 149 | 150 | 151 | 152 | 153 | 154 | 155 | 156 |
157 | 158 | 159 | 160 | 161 | 162 | 163 | 164 | 165 | 166 | 167 |
168 | 169 | 170 | 171 | 172 | 173 | 174 | 175 | 176 | 177 | 178 |
179 | 180 | 181 | 182 | 183 | 184 | 185 | 186 | 187 | 188 | 189 |
190 | 191 | 192 | 193 | 194 | 195 | 196 | 197 | 198 | 199 | 200 |
ALL
*RST:           1
```

Example: See [Example"Enabling static multipath effects"](#) on page 415.

Manual operation: See ["Standard, SV-ID \(source\), Copy To, Standard, SV-ID \(target\)"](#) on page 149

[:SOURce<hw>]:BB:GNSS:RECEiver[:V<st>]:ENVironment:MPATH:COPY:EXECute

Copies the multipath configuration of the source GNSS System and SV ID to the target SV ID and GNSS system or to all SV IDs from a system.

Set the source with:

- `[:SOURce<hw>]:BB:GNSS:RECEiver[:V<st>]:ENVironment:MPATH:SYSTEM`
- `[:SOURce<hw>]:BB:GNSS:RECEiver[:V<st>]:ENVironment:MPATH:SVID`

Set the target with:

- `[:SOURce<hw>]:BB:GNSS:RECEiver[:V<st>]:ENVironment:MPATH:COPY:SYSTEM`
- `[:SOURce<hw>]:BB:GNSS:RECEiver[:V<st>]:ENVironment:MPATH:COPY:SVID`

Setting parameters:

<CopyTo> Event

Example: See [Example"Enabling static multipath effects"](#) on page 415.

Usage: Event

Manual operation: See ["Standard, SV-ID \(source\), Copy To, Standard, SV-ID \(target\)"](#) on page 149

[:SOURce<hw>]:BB:GNSS:SVID<ch>:BEIDou:MPATH[:V<us>:A<gr>]:LOS:ENABLE <EnableLOS>
[:SOURce<hw>]:BB:GNSS:SVID<ch>:GALileo:MPATH[:V<us>:A<gr>]:LOS:ENABLE <EnableLOS>
[:SOURce<hw>]:BB:GNSS:SVID<ch>:GLONass:MPATH[:V<us>:A<gr>]:LOS:ENABLE <EnableLOS>
[:SOURce<hw>]:BB:GNSS:SVID<ch>:QZSS:MPATH[:V<us>:A<gr>]:LOS:ENABLE <EnableLOS>
[:SOURce<hw>]:BB:GNSS:SVID<ch>:NAVic:MPATH[:V<us>:A<gr>]:LOS:ENABLE <EnableLOS>
[:SOURce<hw>]:BB:GNSS:SVID<ch>:SBAS:MPATH[:V<us>:A<gr>]:LOS:ENABLE <EnableLOS>
[:SOURce<hw>]:BB:GNSS:SVID<ch>:GPS:MPATH[:V<us>:A<gr>]:LOS:ENABLE <EnableLOS>

Activates the line-of-sight component.

Parameters:

<EnableLOS> 1 | ON | 0 | OFF

*RST: 1

Example: See [Example"Enabling static multipath effects"](#) on page 415.

Manual operation: See ["Line of Sight \(LOS\)"](#) on page 150

```

[:SOURce<hw>]:BB:GNSS:SVID<ch>:BEIDou:MPATH[:V<us>:A<gr>]:ECHos:
    COUNT <NumberOfEchos>
[:SOURce<hw>]:BB:GNSS:SVID<ch>:GALileo:MPATH[:V<us>:A<gr>]:ECHos:
    COUNT <NumberOfEchos>
[:SOURce<hw>]:BB:GNSS:SVID<ch>:GLONass:MPATH[:V<us>:A<gr>]:ECHos:
    COUNT <NumberOfEchos>
[:SOURce<hw>]:BB:GNSS:SVID<ch>:QZSS:MPATH[:V<us>:A<gr>]:ECHos:
    COUNT <NumberOfEchos>
[:SOURce<hw>]:BB:GNSS:SVID<ch>:NAVic:MPATH[:V<us>:A<gr>]:ECHos:
    COUNT <NumberOfEchos>
[:SOURce<hw>]:BB:GNSS:SVID<ch>:SBAS:MPATH[:V<us>:A<gr>]:ECHos:
    COUNT <NumberOfEchos>
[:SOURce<hw>]:BB:GNSS:SVID<ch>:GPS:MPATH[:V<us>:A<gr>]:ECHos:COUNT
    <NumberOfEchos>

```

Sets the echoes number.

Parameters:

```

<NumberOfEchos>  integer
                  Range:    0 to 9
                  *RST:    0

```

Example: See [Example "Enabling static multipath effects"](#) on page 415.

Manual operation: See ["Number of Echoes"](#) on page 150

```

[:SOURce<hw>]:BB:GNSS:SVID<ch>:GPS:MPATH[:V<us>:A<gr>]:LOS:ICPHase?
[:SOURce<hw>]:BB:GNSS:SVID<ch>:BEIDou:MPATH[:V<us>:A<gr>]:LOS:
    ICPHase?
[:SOURce<hw>]:BB:GNSS:SVID<ch>:BEIDou:MPATH[:V<us>:A<gr>]:
    ECHO<s2us0>:ICPHase <InitCodePhase>
[:SOURce<hw>]:BB:GNSS:SVID<ch>:GALileo:MPATH[:V<us>:A<gr>]:LOS:
    ICPHase?
[:SOURce<hw>]:BB:GNSS:SVID<ch>:GALileo:MPATH[:V<us>:A<gr>]:
    ECHO<s2us0>:ICPHase <InitCodePhase>
[:SOURce<hw>]:BB:GNSS:SVID<ch>:GLONass:MPATH[:V<us>:A<gr>]:LOS:
    ICPHase?
[:SOURce<hw>]:BB:GNSS:SVID<ch>:GLONass:MPATH[:V<us>:A<gr>]:
    ECHO<s2us0>:ICPHase <InitCodePhase>
[:SOURce<hw>]:BB:GNSS:SVID<ch>:QZSS:MPATH[:V<us>:A<gr>]:LOS:
    ICPHase?
[:SOURce<hw>]:BB:GNSS:SVID<ch>:QZSS:MPATH[:V<us>:A<gr>]:
    ECHO<s2us0>:ICPHase <InitCodePhase>
[:SOURce<hw>]:BB:GNSS:SVID<ch>:NAVic:MPATH[:V<us>:A<gr>]:LOS:
    ICPHase?
[:SOURce<hw>]:BB:GNSS:SVID<ch>:NAVic:MPATH[:V<us>:A<gr>]:
    ECHO<s2us0>:ICPHase <InitCodePhase>
[:SOURce<hw>]:BB:GNSS:SVID<ch>:SBAS:MPATH[:V<us>:A<gr>]:LOS:
    ICPHase?

```

```
[ :SOURce<hw>]:BB:GNSS:SVID<ch>:SBAS:MPATH[:V<us>:A<gr>]:
    ECHO<s2us0>:ICPHase <InitCodePhase>
[:SOURce<hw>]:BB:GNSS:SVID<ch>:GPS:MPATH[:V<us>:A<gr>]:ECHO<s2us0>:
    ICPHase <InitCodePhase>
```

Sets an initial code phase for the selected echo.

Parameters:

```
<InitCodePhase>    float
                    Range:    0 to 3000
                    Increment: 0.1
                    *RST:    0
                    Default unit: m
```

Example: See [Example "Enabling static multipath effects"](#) on page 415.

Manual operation: See ["Init. Code Phase"](#) on page 150

```
[ :SOURce<hw>]:BB:GNSS:SVID<ch>:BEIDou:MPATH[:V<us>:A<gr>]:LOS:
    CPDRift?
[:SOURce<hw>]:BB:GNSS:SVID<ch>:BEIDou:MPATH[:V<us>:A<gr>]:
    ECHO<s2us0>:CPDRift <CodePhaseDrift>
[:SOURce<hw>]:BB:GNSS:SVID<ch>:GALileo:MPATH[:V<us>:A<gr>]:LOS:
    CPDRift?
[:SOURce<hw>]:BB:GNSS:SVID<ch>:GALileo:MPATH[:V<us>:A<gr>]:
    ECHO<s2us0>:CPDRift <CodePhaseDrift>
[:SOURce<hw>]:BB:GNSS:SVID<ch>:GLONass:MPATH[:V<us>:A<gr>]:LOS:
    CPDRift?
[:SOURce<hw>]:BB:GNSS:SVID<ch>:GLONass:MPATH[:V<us>:A<gr>]:
    ECHO<s2us0>:CPDRift <CodePhaseDrift>
[:SOURce<hw>]:BB:GNSS:SVID<ch>:QZSS:MPATH[:V<us>:A<gr>]:LOS:CPDRift?
[:SOURce<hw>]:BB:GNSS:SVID<ch>:QZSS:MPATH[:V<us>:A<gr>]:
    ECHO<s2us0>:CPDRift <CodePhaseDrift>
[:SOURce<hw>]:BB:GNSS:SVID<ch>:NAVic:MPATH[:V<us>:A<gr>]:LOS:
    CPDRift?
[:SOURce<hw>]:BB:GNSS:SVID<ch>:NAVic:MPATH[:V<us>:A<gr>]:
    ECHO<s2us0>:CPDRift <CodePhaseDrift>
[:SOURce<hw>]:BB:GNSS:SVID<ch>:SBAS:MPATH[:V<us>:A<gr>]:LOS:
    CPDRift?
[:SOURce<hw>]:BB:GNSS:SVID<ch>:SBAS:MPATH[:V<us>:A<gr>]:
    ECHO<s2us0>:CPDRift <CodePhaseDrift>
[:SOURce<hw>]:BB:GNSS:SVID<ch>:GPS:MPATH[:V<us>:A<gr>]:LOS:CPDRift?
[:SOURce<hw>]:BB:GNSS:SVID<ch>:GPS:MPATH[:V<us>:A<gr>]:ECHO<s2us0>:
    CPDRift <CodePhaseDrift>
```

Sets a code phase drift.

Parameters:

<CodePhaseDrift> float
 Range: 0 to 2000
 Increment: 0.1
 *RST: 0
 Default unit: m/s

Example: See [Example"Enabling static multipath effects"](#) on page 415.

Manual operation: See ["Code Phase Drift"](#) on page 150

```
[:SOURce<hw>]:BB:GNSS:SVID<ch>:BEIDou:MPATH[:V<us>:A<gr>]:LOS:
  POWer?
[:SOURce<hw>]:BB:GNSS:SVID<ch>:BEIDou:MPATH[:V<us>:A<gr>]:
  ECHO<s2us0>:POWer <PowerOffset>
[:SOURce<hw>]:BB:GNSS:SVID<ch>:GALileo:MPATH[:V<us>:A<gr>]:LOS:
  POWer?
[:SOURce<hw>]:BB:GNSS:SVID<ch>:GALileo:MPATH[:V<us>:A<gr>]:
  ECHO<s2us0>:POWer <PowerOffset>
[:SOURce<hw>]:BB:GNSS:SVID<ch>:GLONass:MPATH[:V<us>:A<gr>]:LOS:
  POWer?
[:SOURce<hw>]:BB:GNSS:SVID<ch>:GLONass:MPATH[:V<us>:A<gr>]:
  ECHO<s2us0>:POWer <PowerOffset>
[:SOURce<hw>]:BB:GNSS:SVID<ch>:QZSS:MPATH[:V<us>:A<gr>]:LOS:POWer?
[:SOURce<hw>]:BB:GNSS:SVID<ch>:QZSS:MPATH[:V<us>:A<gr>]:
  ECHO<s2us0>:POWer <PowerOffset>
[:SOURce<hw>]:BB:GNSS:SVID<ch>:NAVic:MPATH[:V<us>:A<gr>]:LOS:POWer?
[:SOURce<hw>]:BB:GNSS:SVID<ch>:NAVic:MPATH[:V<us>:A<gr>]:
  ECHO<s2us0>:POWer <PowerOffset>
[:SOURce<hw>]:BB:GNSS:SVID<ch>:SBAS:MPATH[:V<us>:A<gr>]:LOS:POWer?
[:SOURce<hw>]:BB:GNSS:SVID<ch>:SBAS:MPATH[:V<us>:A<gr>]:
  ECHO<s2us0>:POWer <PowerOffset>
[:SOURce<hw>]:BB:GNSS:SVID<ch>:GPS:MPATH[:V<us>:A<gr>]:LOS:POWer?
[:SOURce<hw>]:BB:GNSS:SVID<ch>:GPS:MPATH[:V<us>:A<gr>]:ECHO<s2us0>:
  POWer <PowerOffset>
```

Sets the additional power offset for the selected echoes.

Parameters:

<PowerOffset> float
 Range: -15 to 0
 Increment: 0.01
 *RST: 0
 Default unit: dB

Example: See [Example"Enabling static multipath effects"](#) on page 415.

Manual operation: See ["Power Offset"](#) on page 151

```

[:SOURce<hw>]:BB:GNSS:SVID<ch>:BEIDou:MPATH[:V<us>:A<gr>]:LOS:
  CPHase?
[:SOURce<hw>]:BB:GNSS:SVID<ch>:BEIDou:MPATH[:V<us>:A<gr>]:
  ECHO<s2us0>:CPHase <CarrierPhase>
[:SOURce<hw>]:BB:GNSS:SVID<ch>:GALileo:MPATH[:V<us>:A<gr>]:LOS:
  CPHase?
[:SOURce<hw>]:BB:GNSS:SVID<ch>:GALileo:MPATH[:V<us>:A<gr>]:
  ECHO<s2us0>:CPHase <CarrierPhase>
[:SOURce<hw>]:BB:GNSS:SVID<ch>:GLONass:MPATH[:V<us>:A<gr>]:LOS:
  CPHase?
[:SOURce<hw>]:BB:GNSS:SVID<ch>:GLONass:MPATH[:V<us>:A<gr>]:
  ECHO<s2us0>:CPHase <CarrierPhase>
[:SOURce<hw>]:BB:GNSS:SVID<ch>:QZSS:MPATH[:V<us>:A<gr>]:LOS:CPHase?
[:SOURce<hw>]:BB:GNSS:SVID<ch>:QZSS:MPATH[:V<us>:A<gr>]:
  ECHO<s2us0>:CPHase <CarrierPhase>
[:SOURce<hw>]:BB:GNSS:SVID<ch>:NAVic:MPATH[:V<us>:A<gr>]:LOS:
  CPHase?
[:SOURce<hw>]:BB:GNSS:SVID<ch>:NAVic:MPATH[:V<us>:A<gr>]:
  ECHO<s2us0>:CPHase <CarrierPhase>
[:SOURce<hw>]:BB:GNSS:SVID<ch>:SBAS:MPATH[:V<us>:A<gr>]:LOS:
  CPHase?
[:SOURce<hw>]:BB:GNSS:SVID<ch>:SBAS:MPATH[:V<us>:A<gr>]:
  ECHO<s2us0>:CPHase <CarrierPhase>
[:SOURce<hw>]:BB:GNSS:SVID<ch>:GPS:MPATH[:V<us>:A<gr>]:LOS:CPHase?
[:SOURce<hw>]:BB:GNSS:SVID<ch>:GPS:MPATH[:V<us>:A<gr>]:ECHO<s2us0>:
  CPHase <CarrierPhase>

```

Sets the carrier phase at the simulation start.

Parameters:

<CarrierPhase>	float
Range:	0 to 6.28
Increment:	0.01
*RST:	0
Default unit:	rad

Example: See [Example"Enabling static multipath effects"](#) on page 415.

Manual operation: See ["Init. Carrier Phase"](#) on page 151

```

[:SOURce<hw>]:BB:GNSS:SVID<ch>:BEIDou:MPATH[:V<us>:A<gr>]:LOS:
  DSHift?
[:SOURce<hw>]:BB:GNSS:SVID<ch>:BEIDou:MPATH[:V<us>:A<gr>]:
  ECHO<s2us0>:DSHift <DopplerShift>
[:SOURce<hw>]:BB:GNSS:SVID<ch>:GALileo:MPATH[:V<us>:A<gr>]:LOS:
  DSHift?
[:SOURce<hw>]:BB:GNSS:SVID<ch>:GALileo:MPATH[:V<us>:A<gr>]:
  ECHO<s2us0>:DSHift <DopplerShift>
[:SOURce<hw>]:BB:GNSS:SVID<ch>:GLONass:MPATH[:V<us>:A<gr>]:LOS:
  DSHift?

```

```

[:SOURce<hw>]:BB:GNSS:SVID<ch>:GLONass:MPATH[:V<us>:A<gr>]:
    ECHO<s2us0>:DSHift <DopplerShift>
[:SOURce<hw>]:BB:GNSS:SVID<ch>:QZSS:MPATH[:V<us>:A<gr>]:LOS:DSHift?
[:SOURce<hw>]:BB:GNSS:SVID<ch>:QZSS:MPATH[:V<us>:A<gr>]:
    ECHO<s2us0>:DSHift <DopplerShift>
[:SOURce<hw>]:BB:GNSS:SVID<ch>:NAVic:MPATH[:V<us>:A<gr>]:LOS:DSHift?
[:SOURce<hw>]:BB:GNSS:SVID<ch>:NAVic:MPATH[:V<us>:A<gr>]:
    ECHO<s2us0>:DSHift <DopplerShift>
[:SOURce<hw>]:BB:GNSS:SVID<ch>:SBAS:MPATH[:V<us>:A<gr>]:LOS:DSHift?
[:SOURce<hw>]:BB:GNSS:SVID<ch>:SBAS:MPATH[:V<us>:A<gr>]:
    ECHO<s2us0>:DSHift <DopplerShift>
[:SOURce<hw>]:BB:GNSS:SVID<ch>:GPS:MPATH[:V<us>:A<gr>]:LOS:DSHift?
[:SOURce<hw>]:BB:GNSS:SVID<ch>:GPS:MPATH[:V<us>:A<gr>]:ECHO<s2us0>:
    DSHift <DopplerShift>

```

Sets an additional Doppler shift.

Parameters:

<DopplerShift>	float
	Range: -10E3 to 10E3
	Increment: 0.01
	*RST: 0
	Default unit: Hz

Example: See [Example "Enabling static multipath effects"](#) on page 415.

Manual operation: See ["Doppler Shift /Hz"](#) on page 151

```

[:SOURce<hw>]:BB:GNSS:SVID<ch>:GPS:MPATH[:V<us>:A<gr>]:LOS:
    AAZimuth?
[:SOURce<hw>]:BB:GNSS:SVID<ch>:BEIDou:MPATH[:V<us>:A<gr>]:LOS:
    AAZimuth?
[:SOURce<hw>]:BB:GNSS:SVID<ch>:BEIDou:MPATH[:V<us>:A<gr>]:
    ECHO<s2us0>:AAZimuth <AoaAzimuth>
[:SOURce<hw>]:BB:GNSS:SVID<ch>:GALileo:MPATH[:V<us>:A<gr>]:LOS:
    AAZimuth?
[:SOURce<hw>]:BB:GNSS:SVID<ch>:GALileo:MPATH[:V<us>:A<gr>]:
    ECHO<s2us0>:AAZimuth <AoaAzimuth>
[:SOURce<hw>]:BB:GNSS:SVID<ch>:GLONass:MPATH[:V<us>:A<gr>]:LOS:
    AAZimuth?
[:SOURce<hw>]:BB:GNSS:SVID<ch>:GLONass:MPATH[:V<us>:A<gr>]:
    ECHO<s2us0>:AAZimuth <AoaAzimuth>
[:SOURce<hw>]:BB:GNSS:SVID<ch>:QZSS:MPATH[:V<us>:A<gr>]:LOS:
    AAZimuth?
[:SOURce<hw>]:BB:GNSS:SVID<ch>:QZSS:MPATH[:V<us>:A<gr>]:
    ECHO<s2us0>:AAZimuth <AoaAzimuth>
[:SOURce<hw>]:BB:GNSS:SVID<ch>:NAVic:MPATH[:V<us>:A<gr>]:LOS:
    AAZimuth?
[:SOURce<hw>]:BB:GNSS:SVID<ch>:NAVic:MPATH[:V<us>:A<gr>]:
    ECHO<s2us0>:AAZimuth <AoaAzimuth>

```

```
[ :SOURce<hw>]:BB:GNSS:SVID<ch>:SBAS:MPATH[:V<us>:A<gr>]:LOS:
  AAZimuth?
[ :SOURce<hw>]:BB:GNSS:SVID<ch>:SBAS:MPATH[:V<us>:A<gr>]:
  ECHO<s2us0>:AAZimuth <AoaAzimuth>
[ :SOURce<hw>]:BB:GNSS:SVID<ch>:GPS:MPATH[:V<us>:A<gr>]:ECHO<s2us0>:
  AAZimuth <AoaAzimuth>
```

Sets the angle of arrival azimuth.

Parameters:

```
<AoaAzimuth>      float
                   Range:      0 to 6.28
                   Increment:  0.01
                   *RST:       0
                   Default unit: rad
```

Example: See [Example"Enabling static multipath effects"](#) on page 415.

Manual operation: See ["AoA Elevation, AoA Azimuth"](#) on page 151

```
[ :SOURce<hw>]:BB:GNSS:SVID<ch>:GPS:MPATH[:V<us>:A<gr>]:LOS:
  AELEVation?
[ :SOURce<hw>]:BB:GNSS:SVID<ch>:BEIDou:MPATH[:V<us>:A<gr>]:LOS:
  AELEVation?
[ :SOURce<hw>]:BB:GNSS:SVID<ch>:BEIDou:MPATH[:V<us>:A<gr>]:
  ECHO<s2us0>:AELEVation <AoaElevation>
[ :SOURce<hw>]:BB:GNSS:SVID<ch>:GALileo:MPATH[:V<us>:A<gr>]:LOS:
  AELEVation?
[ :SOURce<hw>]:BB:GNSS:SVID<ch>:GALileo:MPATH[:V<us>:A<gr>]:
  ECHO<s2us0>:AELEVation <AoaElevation>
[ :SOURce<hw>]:BB:GNSS:SVID<ch>:GLONass:MPATH[:V<us>:A<gr>]:LOS:
  AELEVation?
[ :SOURce<hw>]:BB:GNSS:SVID<ch>:GLONass:MPATH[:V<us>:A<gr>]:
  ECHO<s2us0>:AELEVation <AoaElevation>
[ :SOURce<hw>]:BB:GNSS:SVID<ch>:QZSS:MPATH[:V<us>:A<gr>]:LOS:
  AELEVation?
[ :SOURce<hw>]:BB:GNSS:SVID<ch>:QZSS:MPATH[:V<us>:A<gr>]:
  ECHO<s2us0>:AELEVation <AoaElevation>
[ :SOURce<hw>]:BB:GNSS:SVID<ch>:NAVic:MPATH[:V<us>:A<gr>]:LOS:
  AELEVation?
[ :SOURce<hw>]:BB:GNSS:SVID<ch>:NAVic:MPATH[:V<us>:A<gr>]:
  ECHO<s2us0>:AELEVation <AoaElevation>
[ :SOURce<hw>]:BB:GNSS:SVID<ch>:SBAS:MPATH[:V<us>:A<gr>]:LOS:
  AELEVation?
[ :SOURce<hw>]:BB:GNSS:SVID<ch>:SBAS:MPATH[:V<us>:A<gr>]:
  ECHO<s2us0>:AELEVation <AoaElevation>
[ :SOURce<hw>]:BB:GNSS:SVID<ch>:GPS:MPATH[:V<us>:A<gr>]:ECHO<s2us0>:
  AELEVation <AoaElevation>
```

Sets the angle of arrival elevation.

Parameters:

<AoaElevation> float
 Range: 0 to 6.28
 Increment: 0.01
 *RST: 0
 Default unit: rad

Example: See [Example "Enabling static multipath effects"](#) on page 415.

Manual operation: See ["AoA Elevation, AoA Azimuth"](#) on page 151

22.9 Atmospheric configuration commands

Example: Configuring the ionospheric and troposphere models

```
SOURcel:BB:GNSS:SYSTEM:GPS:STATE 1
SOURcel:BB:GNSS:ATMospheric:TROPospheric:MODEl MOPS

SOURcel:BB:GNSS:ATMospheric:IONospheric:MODEl KLOBuchar
SOURcel:BB:GPS:ATMospheric:IONospheric:KLOBuchar:ALPHA0?
// 5
SOURCE:BB:GPS:ATMospheric:GPS:IONospheric:ALPHA0?
// 5

SOURcel:BB:GNSS:ATMospheric:IONospheric:MODEl NEQuick
SOURcel:BB:GPS:ATMospheric:IONospheric:NEQuick:UMSN OFF
SOURcel:BB:GPS:ATMospheric:IONospheric:NEQuick:SUNSpot 100
SOURcel:BB:GPS:ATMospheric:IONospheric:NEQuick:SFLux 145.4

SOURcel:BB:GNSS:ATMospheric:IONospheric:MODEl MOPS
```

Example: Importing grid files

The example shows how to import a grid configuration using multiple files with different extensions.

For a detailed file description, see:

- ["SBAS correction file download"](#) on page 309 for *.ems and *.nsth files.
- [Chapter F, "Ionospheric grid file format"](#), on page 681 for *.iono_grid files.

Additionally, a grid configuration can simply be loaded from a predefined file or user-defined file.

```
*****
// Add files with *.ems, *.nsth or *.iono_grid extension to an import file list.
*****
SOURcel:BB:GNSS:ATMospheric:IONospheric:MOPS:IMPORt:ADD:FILE:EMS
"/var/user/gnss/PRN120_y2018_d067_h14.ems"
SOURcel:BB:GNSS:ATMospheric:IONospheric:MOPS:IMPORt:ADD:FILE:NSTB
```

Atmospheric configuration commands

```

"/var/user/gnss/wfaip1c1_84c1_1991_02.nstb"
SOURCEl:BB:GNSS:ATMospheric:IONospheric:MOPS:IMPorT:ADD:FILE:GRID
"/var/user/gnss/Mops_2018_03_07.iono_grid"
*****
// Alternatively, add all files from a directory to an import file list.
*****
SOURCEl:BB:GNSS:ATMospheric:IONospheric:MOPS:IMPorT:ADD:DIR "/var/user/gnss"
*****
// Query the files to import.
*****
SOURCEl:BB:GNSS:ATMospheric:IONospheric:MOPS:IMPorT:LIST?
// "/var/user/gnss/Mops_2018_03_07.iono_grid;19.02.2014 00:03:40;20.02.2014 00:03:40,
// /var/user/gnss/PRN120_y2018_d067_h14.ems;08.03.2018 14:00:00;08.03.2018 14:59:59,
// /var/user/gnss/wfaip1c1_84c1_1991_02.nstb;06.03.2018 00:00:02;07.03.2018 00:00:02"
// For each file the filename, start/end date and time are listed.
*****
// Remove a particular file from the import file list.
*****
SOURCEl:BB:GNSS:ATMospheric:IONospheric:MOPS:IMPorT:REMOVe:FILEl
SOURCEl:BB:GNSS:ATMospheric:IONospheric:MOPS:IMPorT:LIST?
// "/var/user/gnss/PRN120_y2018_d067_h14.ems;08.03.2018 14:00:00;08.03.2018 14:59:59,
// /var/user/gnss/wfaip1c1_84c1_1991_02.nstb;06.03.2018 00:00:02;07.03.2018 00:00:02"
*****
// Load all files from the latest import file query and export the configuration.
*****
SOURCEl:BB:GNSS:ATMospheric:IONospheric:MOPS:IMPorT:EXECute
SOURCEl:BB:GNSS:ATMospheric:IONospheric:MOPS:EXPorT
"/var/user/gnss/Mops_2018_03_08.iono_grid"
*****
// Reload a previous grid configuration.
*****
SOURCEl:BB:GNSS:ATMospheric:IONospheric:MOPS:FILE
"/var/user/gnss/Mops_2018_03_07.iono_grid"

```

Commands:

[SOURCE<hw>]:BB:GNSS:ATMospheric:TROPospheric:MODEL.....	430
[SOURCE<hw>]:BB:GNSS:ATMospheric:IONospheric:MODEL.....	430
[SOURCE<hw>]:BB:GNSS:ATMospheric:IONospheric:NEQuick:SFLux.....	430
[SOURCE<hw>]:BB:GNSS:ATMospheric:IONospheric:NEQuick:SUNSpot.....	430
[SOURCE<hw>]:BB:GNSS:ATMospheric:IONospheric:NEQuick:UMSN.....	431
[SOURCE<hw>]:BB:GNSS:ATMospheric:IONospheric:MOPS:FILE.....	431
[SOURCE<hw>]:BB:GNSS:ATMospheric:IONospheric:MOPS:DISPlay.....	431
[SOURCE<hw>]:BB:GNSS:ATMospheric:IONospheric:MOPS:EXPorT.....	432
[SOURCE<hw>]:BB:GNSS:ATMospheric:IONospheric:MOPS:IMPorT:ADD:DIR.....	432
[SOURCE<hw>]:BB:GNSS:ATMospheric:IONospheric:MOPS:IMPorT:ADD:FILE:EMS.....	432
[SOURCE<hw>]:BB:GNSS:ATMospheric:IONospheric:MOPS:IMPorT:ADD:FILE:NSTB.....	432
[SOURCE<hw>]:BB:GNSS:ATMospheric:IONospheric:MOPS:IMPorT:ADD:FILE:GRID.....	432
[SOURCE<hw>]:BB:GNSS:ATMospheric:IONospheric:MOPS:IMPorT:LIST?.....	433
[SOURCE<hw>]:BB:GNSS:ATMospheric:IONospheric:MOPS:IMPorT:EXECute.....	433

[:SOURce<hw>]:BB:GNSS:ATMospheric:IONospheric:MOPS:IMPort:REMove:ALL..... 433
 [:SOURce<hw>]:BB:GNSS:ATMospheric:IONospheric:MOPS:IMPort:REMove:FILE<ch>..... 433
 [:SOURce<hw>]:BB:GNSS:ATMospheric:IONospheric:KLOBuchar:ALPHa<ch0>:UNSCaled. 433
 [:SOURce<hw>]:BB:GNSS:ATMospheric:IONospheric:KLOBuchar:BETA<ch0>:UNSCaled... 434

[:SOURce<hw>]:BB:GNSS:ATMospheric:TROPospheric:MODEl <Model>

Determines the tropospheric model.

Parameters:

<Model> NONE | STANag | MOPS
 *RST: NONE

Example: See [Example"Configuring the ionospheric and troposphere models"](#) on page 428

Manual operation: See ["Tropospheric Model"](#) on page 204

[:SOURce<hw>]:BB:GNSS:ATMospheric:IONospheric:MODEl <Model>

Determines the applied ionospheric model.

Parameters:

<Model> NONE | KLOBuchar | MOPS | NEQuick
 *RST: NONE

Example: See [Example"Configuring the ionospheric and troposphere models"](#) on page 428

Manual operation: See ["Ionospheric Model"](#) on page 205

**[:SOURce<hw>]:BB:GNSS:ATMospheric:IONospheric:NEQuick:SFLux
 <SolarFlux>**

Sets the solar flux level.

Parameters:

<SolarFlux> float
 Range: 0 to 300
 Increment: 1E-3
 *RST: 0

Example: See [Example"Configuring the ionospheric and troposphere models"](#) on page 428

Manual operation: See ["NeQuick Parameters"](#) on page 206

**[:SOURce<hw>]:BB:GNSS:ATMospheric:IONospheric:NEQuick:SUNSpot
 <SunspotNumber>**

Sets the sunspot number.

Parameters:

<SunspotNumber> float
 Range: -99.636 to 248.870
 Increment: 1E-3
 *RST: 100

Example: See [Example"Configuring the ionospheric and troposphere models"](#) on page 428

Manual operation: See ["NeQuick Parameters"](#) on page 206

[:SOURCE<hw>]:BB:GNSS:ATMospheric:IONospheric:NEQuick:UMSN <State>

Enables the instrument to use the measured sunspot number value.

Parameters:

<State> 1 | ON | 0 | OFF
 *RST: 0

Example: See [Example"Configuring the ionospheric and troposphere models"](#) on page 428

Manual operation: See ["NeQuick Parameters"](#) on page 206

[:SOURCE<hw>]:BB:GNSS:ATMospheric:IONospheric:MOPS:FILE <Filename>

Select a ionospheric grid file.

Parameters:

<Filename> string
 To load a predefined file, specify only the filename.
 To load a user-defined file, specify the absolute file path with filename and extension (*.iono_grid).

Example: See [Example"Importing grid files"](#) on page 428

Manual operation: See ["MOPS-DO-229D"](#) on page 207

[:SOURCE<hw>]:BB:GNSS:ATMospheric:IONospheric:MOPS:DISPlay <DisplayType>

Toggles between indication of the vertical delay and GIVEI values.

Parameters:

<DisplayType> GIVEI | VDElay
 *RST: VDElay

Example: SOURCE1:BB:GNSS:ATMospheric:IONospheric:MOPS:DISPlay VDElay

Manual operation: See ["View Type"](#) on page 207

```
[ :SOURCE<hw>]:BB:GNSS:ATMospheric:IONospheric:MOPS:EXPort <Filename>
```

Saves the current ionospheric grid configuration in a file.

Setting parameters:

<Filename> string
Specify the file path, filename and extension. Allowed file extensions are *.rs_ion or *.iono_grid.

Example: SOURCE1:BB:GNSS:ATMospheric:IONospheric:MOPS:EXPort
/var/user/GnssMops1.rs_ion

Usage: Setting only

Manual operation: See ["Export Grid"](#) on page 210

```
[ :SOURCE<hw>]:BB:GNSS:ATMospheric:IONospheric:MOPS:IMPort:ADD:DIR  
 <Directory>
```

Adds a set of files to the input files selection in one step.

Setting parameters:

<Directory> string
File path

Example: See [Example"Importing grid files"](#) on page 428

Usage: Setting only

Manual operation: See ["Import Grid"](#) on page 207

```
[ :SOURCE<hw>]:BB:GNSS:ATMospheric:IONospheric:MOPS:IMPort:ADD:FILE:  
 EMS <Filename>  
 [ :SOURCE<hw>]:BB:GNSS:ATMospheric:IONospheric:MOPS:IMPort:ADD:FILE:  
 NSTB <Filename>  
 [ :SOURCE<hw>]:BB:GNSS:ATMospheric:IONospheric:MOPS:IMPort:ADD:FILE:  
 GRID <Filename>
```

Add *.ems, *.nsth or *.iono_grid files to an import file list.

Setting parameters:

<Filename> string
The <Filename> string comprises the file directory, filename and extension. For more information about *.ems and *.nsth files, see ["SBAS correction file download"](#) on page 309 .
*.iono_grid files, see [Example"Ionospheric grid file content \(extract\)"](#) on page 681.

Example: See [Example"Importing grid files"](#) on page 428

Usage: Setting only

Manual operation: See ["Import Grid"](#) on page 207

[:SOURce<hw>]:BB:GNSS:ATMospheric:IONospheric:MOPS:IMPPort:LIST?

Queries all files of the import file list in a comma separated list.

Example: See [Example"Importing grid files"](#) on page 428

Usage: Query only

Manual operation: See ["Import Grid"](#) on page 207

[:SOURce<hw>]:BB:GNSS:ATMospheric:IONospheric:MOPS:IMPPort:EXECute

Loads all files from an import file list.

Example: See [Example"Importing grid files"](#) on page 428

Usage: Event

Manual operation: See ["Import Grid"](#) on page 207

**[:SOURce<hw>]:BB:GNSS:ATMospheric:IONospheric:MOPS:IMPPort:REMOve:
ALL**

**[:SOURce<hw>]:BB:GNSS:ATMospheric:IONospheric:MOPS:IMPPort:REMOve:
FILE<ch>**

Remove all or one particular file at the n-th position from an import file list.

Suffix:

<ch> 1 to n

Example: See [Example"Importing grid files"](#) on page 428

Usage: Event

Manual operation: See ["Import Grid"](#) on page 207

**[:SOURce<hw>]:BB:GNSS:ATMospheric:IONospheric:KLOBuchar:ALPHA<ch0>:
UNSCaled <AlphaUnscaled>**

Sets the klobuchar parameters alpha_0 to alpha_3.

Suffix:

<ch0> 0 to 3

Parameters:

<AlphaUnscaled> float
 Range: dynamic
 Increment: dynamicResolution
 *RST: 0

Example: See [Example"Configuring the ionospheric and troposphere models"](#) on page 428

Manual operation: See ["Klobuchar Parameters"](#) on page 205

```
[:SOURce<hw>]:BB:GNSS:ATMospheric:IONospheric:KLOBuchar:BETA<ch0>:
UNSCaled <BetaUnscaled>
```

Sets the klobuchar parameters beta_0 to beta_3.

Suffix:

<ch0> 0 to 3

Parameters:

<BetaUnscaled> integer
 Range: dynamic
 *RST: 0

Example: See [Example"Configuring the ionospheric and troposphere models"](#) on page 428

Manual operation: See "[Klobuchar Parameters](#)" on page 205

22.10 AWGN configuration

Option: R&S SMW-K62

Example: Configure additive noise

```
SOURce1:BB:GNSS:AWGN:MODE ADD
SOURce1:BB:GNSS:AWGN:FREQuency:REFeRence? 1389225000 Hz
SOURce1:BB:GNSS:AWGN:RF1:CONFIg MANual
SOURce1:BB:GNSS:AWGN:BWIDth 500000000
SOURce1:BB:GNSS:AWGN:CNDRatio 30
SOURce1:BB:GNSS:AWGN:STATe 1
```

Example: Configure a CW interferer

```
SOURce1:BB:GNSS:AWGN:MODE CW
SOURce1:BB:GNSS:AWGN:FREQuency:TARGet 100000000
SOURce1:BB:GNSS:AWGN:JSRatio 30
SOURce1:BB:GNSS:AWGN:STATe 1
```

Commands:

[:SOURce<hw>]:BB:GNSS:AWGN[:RF<ch>]:BWIDth.....	435
[:SOURce<hw>]:BB:GNSS:AWGN[:RF<ch>]:CNDRatio.....	435
[:SOURce<hw>]:BB:GNSS:AWGN[:RF<ch>]:CONFIg.....	435
[:SOURce<hw>]:BB:GNSS:AWGN[:RF<ch>]:FREQuency:CENTer.....	436
[:SOURce<hw>]:BB:GNSS:AWGN[:RF<ch>]:FREQuency:CW.....	436
[:SOURce<hw>]:BB:GNSS:AWGN[:RF<ch>]:FREQuency:REFeRence?.....	436
[:SOURce<hw>]:BB:GNSS:AWGN[:RF<ch>]:FREQuency:TARGet.....	436
[:SOURce<hw>]:BB:GNSS:AWGN[:RF<ch>]:JSRatio.....	437
[:SOURce<hw>]:BB:GNSS:AWGN[:RF<ch>]:MODE.....	437
[:SOURce<hw>]:BB:GNSS:AWGN[:RF<ch>]:STATe.....	437

[[:SOURce<hw>]:BB:GNSS:AWGN[:RF<ch>]:BWIDth <SystemBAndwidth>

Sets the RF bandwidth to which the set carrier/noise ratio relates.

Within this frequency range, the signal is superimposed with a noise signal which level corresponds exactly to the set C/N or S/N ratio.

Parameters:

<SystemBAndwidth> integer

Range: 1E3 to 500E6

*RST: 500E6

Example: See [Example"Configure additive noise"](#) on page 434.

Manual operation: See ["Bandwidth"](#) on page 198

[[:SOURce<hw>]:BB:GNSS:AWGN[:RF<ch>]:CNDRatio <CnDensityRatio>

Sets the carrier power to noise power ratio *C/N ratio*, that is the difference of carrier power and noise power:

C/N ratio = Carrier power - Noise power

*Noise power = Reference power + 10 * log₁₀(System Bandwidth) - C/ N₀*

Parameters:

<CnDensityRatio> float

Range: 0 to 55

Increment: 0.01

*RST: 40

Example: See [Example"Configure additive noise"](#) on page 434.

Manual operation: See ["Carrier/Noise Density Ratio - C/N₀"](#) on page 197

[[:SOURce<hw>]:BB:GNSS:AWGN[:RF<ch>]:CONFig <AutoConfigState>

Defines how noise bandwidth and noise center frequency are set.

Parameters:

<AutoConfigState> AUTO | MANual

AUTO

Sets bandwidth and center frequency automatically.

MANual

Enables configuration of noise and CW parameters.

*RST: AUTO

Example: See [Example"Configure additive noise"](#) on page 434.

Manual operation: See ["Noise Config"](#) on page 198

[:SOURce<hw>]:BB:GNSS:AWGN[:RF<ch>]:FREQUENCY:CENTer
 <CenterFrequency>

Sets center frequency of the noise signal.

Parameters:

<CenterFrequency> integer
 Range: 1E9 to 2E9
 *RST: 1.389225E9

Example: See [Example"Configure additive noise"](#) on page 434.

Manual operation: See ["Center Frequency"](#) on page 198

[:SOURce<hw>]:BB:GNSS:AWGN[:RF<ch>]:FREQUENCY:CW <CwFrequency>

Sets the frequency of the CW interfering signal.

Parameters:

<CwFrequency> integer
 Range: 1E9 to 2E9
 *RST: 1.389225E9
 Default unit: Hz

Example: See [Example"Configure a CW interferer"](#) on page 434.

Manual operation: See ["CW Frequency"](#) on page 198

[:SOURce<hw>]:BB:GNSS:AWGN[:RF<ch>]:FREQUENCY:REFerence?

Queries the reference frequency, that is the RF carrier frequency.

Set the frequency with the following remote command:

SOURce1:FREQUENCY

Return values:

<ReferenceFreque> integer
 Range: 1E9 to 2E9
 *RST: 1E9

Example: See [Example"Configure additive noise"](#) on page 434.

Usage: Query only

[:SOURce<hw>]:BB:GNSS:AWGN[:RF<ch>]:FREQUENCY:TARGet <CwFreqOffset>

Sets the frequency offset of the sine wave relative to the "Reference Frequency".

Parameters:

<CwFreqOffset> float
 Range: -250E6 to 250E6
 Increment: 1E-3
 *RST: 0

Example: See [Example"Configure a CW interferer"](#) on page 434.

[:SOURce<hw>]:BB:GNSS:AWGN[:RF<ch>]:JSRatio <JsRatio>

Sets the jammer (interferer) power to signal power ratio *C/I ratio*, that is the difference of carrier power and noise power:

C/I ratio = Carrier power - Interferer power

Interferer power = Reference power + J/S

Parameters:

<JsRatio> float
 Range: -50 to 50
 Increment: 0.01
 *RST: 40

Example: See [Example"Configure a CW interferer"](#) on page 434.

Manual operation: See ["Jammer/Signal Ratio - J/S"](#) on page 197

[:SOURce<hw>]:BB:GNSS:AWGN[:RF<ch>]:MODE <AwgnMode>

Activates/deactivates the generation of an AWGN signal. The interferer (AWGN or CW interferer, depending on the selected mode) is generated after the generator is activated.

Parameters:

<AwgnMode> ADD | CW
 *RST: ADD

Example: See [Example"Configure additive noise"](#) on page 434.

Manual operation: See ["Mode"](#) on page 197

[:SOURce<hw>]:BB:GNSS:AWGN[:RF<ch>]:STATe <AwgnState>

Activates/deactivates the generation of an AWGN signal. The interferer (AWGN or CW interferer, depending on the selected mode) is generated after the generator is activated.

Parameters:

<AwgnState> 1 | ON | 0 | OFF
 *RST: 0

Example: See [Example"Configure additive noise"](#) on page 434.

Manual operation: See "State" on page 197

22.11 Satellites constellation

Example: Configuring the satellite's constellation

```

SOURCEl:BB:GNSS:PRESet
SOURCEl:BB:GNSS:TMODe NAV

SOURCEl:BB:GNSS:SYSTem:GPS:STATe 1
SOURCEl:BB:GNSS:SYSTem:GALileo:STATe 1

SOURCEl:BB:GNSS:SV:SELection:MODe ELEv
SOURCEl:BB:GNSS:SV:SELection:EOBScuration:REFerence LHOR
SOURCEl:BB:GNSS:SV:SELection:EOBScuration:ANGLe 5
// query the number of satellites available
SOURCEl:BB:GNSS:SV:SELection:GPS:AVAILable?
// 37
SOURCEl:BB:GNSS:SV:SELection:GALileo:AVAILable?
// 29
SOURCEl:BB:GNSS:SV:SELection:GPS:MIN 1
SOURCEl:BB:GNSS:SV:SELection:GPS:MAX 24
SOURCEl:BB:GNSS:SV:SELection:GALileo:MIN 1
SOURCEl:BB:GNSS:SV:SELection:GALileo:MAX 15
// query the number of active statellites in the constellation
SOURCEl:BB:GNSS:SV:SELection:GPS:ACTive?
// 10
SOURCEl:BB:GNSS:SV:SELection:GALileo:ACTive?
// 8

// Query all SV IDs per GNSS system, i.e. SVs included in and excluded
// from the satellite constellation.
SOURCEl:BB:GNSS:SVID:GPS:LIST:ALL?
// 1,2,3,4,5,6,7,8,9,10,11,12,13,14,15,16,17,18,19,20,21,22,23,24,25,26,27,
// 28,29,30,31,32,33,34,35,36,37
// Query valid SV IDs per GNSS system, i.e. SVs included in the
// satellite constellation.
SOURCEl:BB:GNSS:SVID:GPS:LIST:VALid?
// 1,2,3,4,5,6,7,8,9,10,11,12,13,14,15,16,17,18,19,20,21,22,23,24,25,26,27,
// 28,29,30,31
// Query, if an SV ID is healhy or not.
SOURCEl:BB:GNSS:SVID1:GPS:HEALthy?
// 1
SOURCEl:BB:GNSS:SVID30:GPS:HEALthy?
// 0
// Query, if an SV ID is visible or not.
SOURCEl:BB:GNSS:SVID1:GPS:VISibility:STATe?
// 1

```

```
SOURcel:BB:GNSS:SVID30:GPS:VISibility:STATe?
// 0
```

```
SOURcel:BB:GNSS:SVID1:GPS:STATe 1
SOURcel:BB:GNSS:SVID1:GPS:POWer:OFFSet -10
```

Example: Importing a satellite constellation

```
SOURcel:BB:GNSS:SYSTem:GPS:STATe 1
SOURcel:BB:GNSS:SYSTem:GALileo:STATe 1

// Import a GPS satellite constellation source file.
SOURcel:BB:GNSS:SV:IMPort:GPS:FILE:CONStellation
"/var/user/19_02_2014_gps.txt"
SOURcel:BB:GNSS:SV:IMPort:GPS:EXECute

// Import separate constellation source and navigation message file.
SOURcel:BB:GNSS:SV:IMPort:GPS:FILE:CONStellation
"/var/user/19_02_2014_gps.txt"
SOURcel:BB:GNSS:SV:IMPort:GPS:UDSource 1
SOURcel:BB:GNSS:SV:IMPort:GPS:FILE:NMESsage
"/var/user/19_02_2014_gps.14n"
// Apply data from the constellation source file to all active GNSS systems.
SOURcel:BB:GNSS:SV:IMPort:GPS:UALL 0
SOURcel:BB:GNSS:SV:IMPort:GPS:EXECute
```

Commands:

[SOURce<hw>]:BB:GNSS:SV:SELection:MODE.....	441
[SOURce<hw>]:BB:GNSS:SV:SELection:EOBScuration:REFerence.....	441
[SOURce<hw>]:BB:GNSS:SV:SELection:EOBScuration:ANGLE.....	442
[SOURce<hw>]:BB:GNSS:SV:SELection:CHANnels:MAX.....	442
[SOURce<hw>]:BB:GNSS:SV:SELection:SBAS:MIN.....	442
[SOURce<hw>]:BB:GNSS:SV:SELection:SBAS:MAX.....	442
[SOURce<hw>]:BB:GNSS:SV:SELection:NAVic:MIN.....	442
[SOURce<hw>]:BB:GNSS:SV:SELection:NAVic:MAX.....	442
[SOURce<hw>]:BB:GNSS:SV:SELection:QZSS:MIN.....	442
[SOURce<hw>]:BB:GNSS:SV:SELection:QZSS:MAX.....	442
[SOURce<hw>]:BB:GNSS:SV:SELection:BEIDou:MIN.....	442
[SOURce<hw>]:BB:GNSS:SV:SELection:BEIDou:MAX.....	442
[SOURce<hw>]:BB:GNSS:SV:SELection:GLONass:MIN.....	442
[SOURce<hw>]:BB:GNSS:SV:SELection:GLONass:MAX.....	442
[SOURce<hw>]:BB:GNSS:SV:SELection:GALileo:MIN.....	443
[SOURce<hw>]:BB:GNSS:SV:SELection:GALileo:MAX.....	443
[SOURce<hw>]:BB:GNSS:SV:SELection:GPS:MIN.....	443
[SOURce<hw>]:BB:GNSS:SV:SELection:GPS:MAX.....	443
[SOURce<hw>]:BB:GNSS:SV:SELection:SBAS:ACTive?.....	443
[SOURce<hw>]:BB:GNSS:SV:SELection:NAVic:ACTive?.....	443
[SOURce<hw>]:BB:GNSS:SV:SELection:QZSS:ACTive?.....	443
[SOURce<hw>]:BB:GNSS:SV:SELection:BEIDou:ACTive?.....	443
[SOURce<hw>]:BB:GNSS:SV:SELection:GLONass:ACTive?.....	443
[SOURce<hw>]:BB:GNSS:SV:SELection:GALileo:ACTive?.....	443

[SOURce<hw>]:BB:GNSS:SV:SELection:GPS:ACTive?	443
[SOURce<hw>]:BB:GNSS:SV:SELection:SBAS:AVAIlable?	443
[SOURce<hw>]:BB:GNSS:SV:SELection:NAVic:AVAIlable?	443
[SOURce<hw>]:BB:GNSS:SV:SELection:QZSS:AVAIlable?	443
[SOURce<hw>]:BB:GNSS:SV:SELection:BEIDou:AVAIlable?	443
[SOURce<hw>]:BB:GNSS:SV:SELection:GLONass:AVAIlable?	443
[SOURce<hw>]:BB:GNSS:SV:SELection:GALileo:AVAIlable?	443
[SOURce<hw>]:BB:GNSS:SV:SELection:GPS:AVAIlable?	443
[SOURce<hw>]:BB:GNSS:SVID:SBAS:LIST:ALL?	444
[SOURce<hw>]:BB:GNSS:SVID:NAVic:LIST:ALL?	444
[SOURce<hw>]:BB:GNSS:SVID:QZSS:LIST:ALL?	444
[SOURce<hw>]:BB:GNSS:SVID:BEIDou:LIST:ALL?	444
[SOURce<hw>]:BB:GNSS:SVID:GLONass:LIST:ALL?	444
[SOURce<hw>]:BB:GNSS:SVID:GALileo:LIST:ALL?	444
[SOURce<hw>]:BB:GNSS:SVID:GPS:LIST:ALL?	444
[SOURce<hw>]:BB:GNSS:SVID:SBAS:LIST[:VALid]?	444
[SOURce<hw>]:BB:GNSS:SVID:NAVic:LIST[:VALid]?	444
[SOURce<hw>]:BB:GNSS:SVID:QZSS:LIST[:VALid]?	444
[SOURce<hw>]:BB:GNSS:SVID:BEIDou:LIST[:VALid]?	444
[SOURce<hw>]:BB:GNSS:SVID:GLONass:LIST[:VALid]?	444
[SOURce<hw>]:BB:GNSS:SVID:GALileo:LIST[:VALid]?	444
[SOURce<hw>]:BB:GNSS:SVID:GPS:LIST[:VALid]?	444
[SOURce<hw>]:BB:GNSS:SVID<ch>:SBAS:HEALTHy	444
[SOURce<hw>]:BB:GNSS:SVID<ch>:NAVic:HEALTHy	444
[SOURce<hw>]:BB:GNSS:SVID<ch>:QZSS:HEALTHy	444
[SOURce<hw>]:BB:GNSS:SVID<ch>:BEIDou:HEALTHy	445
[SOURce<hw>]:BB:GNSS:SVID<ch>:GLONass:HEALTHy	445
[SOURce<hw>]:BB:GNSS:SVID<ch>:GALileo:HEALTHy	445
[SOURce<hw>]:BB:GNSS:SVID<ch>:GPS:HEALTHy	445
[SOURce<hw>]:BB:GNSS:SVID<ch>:SBAS:VISibility:STATe?	446
[SOURce<hw>]:BB:GNSS:SVID<ch>:NAVic:VISibility:STATe?	446
[SOURce<hw>]:BB:GNSS:SVID<ch>:QZSS:VISibility:STATe?	446
[SOURce<hw>]:BB:GNSS:SVID<ch>:BEIDou:VISibility:STATe?	446
[SOURce<hw>]:BB:GNSS:SVID<ch>:GLONass:VISibility:STATe?	446
[SOURce<hw>]:BB:GNSS:SVID<ch>:GALileo:VISibility:STATe?	446
[SOURce<hw>]:BB:GNSS:SVID<ch>:GPS:VISibility:STATe?	446
[SOURce<hw>]:BB:GNSS:SV:IMPorT:NAVic:FILE:CONStellation	446
[SOURce<hw>]:BB:GNSS:SV:IMPorT:QZSS:FILE:CONStellation	446
[SOURce<hw>]:BB:GNSS:SV:IMPorT:BEIDou:FILE:CONStellation	446
[SOURce<hw>]:BB:GNSS:SV:IMPorT:GLONass:FILE:CONStellation	446
[SOURce<hw>]:BB:GNSS:SV:IMPorT:GALileo:FILE:CONStellation	446
[SOURce<hw>]:BB:GNSS:SV:IMPorT:GPS:FILE:CONStellation	446
[SOURce<hw>]:BB:GNSS:SV:IMPorT:NAVic:UDSource	447
[SOURce<hw>]:BB:GNSS:SV:IMPorT:QZSS:UDSource	447
[SOURce<hw>]:BB:GNSS:SV:IMPorT:BEIDou:UDSource	447
[SOURce<hw>]:BB:GNSS:SV:IMPorT:GLONass:UDSource	447
[SOURce<hw>]:BB:GNSS:SV:IMPorT:GALileo:UDSource	447
[SOURce<hw>]:BB:GNSS:SV:IMPorT:GPS:UDSource	447
[SOURce<hw>]:BB:GNSS:SV:IMPorT:NAVic:FILE:NMESSage	447
[SOURce<hw>]:BB:GNSS:SV:IMPorT:QZSS:FILE:NMESSage	447

<code>[:SOURce<hw>]:BB:GNSS:SV:IMPorT:BEIDou:FILE:NMEsSage</code>	447
<code>[:SOURce<hw>]:BB:GNSS:SV:IMPorT:GLONass:FILE:NMEsSage</code>	447
<code>[:SOURce<hw>]:BB:GNSS:SV:IMPorT:GALileo:FILE:NMEsSage</code>	447
<code>[:SOURce<hw>]:BB:GNSS:SV:IMPorT:GPS:FILE:NMEsSage</code>	447
<code>[:SOURce<hw>]:BB:GNSS:SV:IMPorT:BEIDou:UALL</code>	447
<code>[:SOURce<hw>]:BB:GNSS:SV:IMPorT:GALileo:UALL</code>	447
<code>[:SOURce<hw>]:BB:GNSS:SV:IMPorT:GLONass:UALL</code>	447
<code>[:SOURce<hw>]:BB:GNSS:SV:IMPorT:GPS:UALL</code>	447
<code>[:SOURce<hw>]:BB:GNSS:SV:IMPorT:NAVic:UALL</code>	447
<code>[:SOURce<hw>]:BB:GNSS:SV:IMPorT:QZSS:UALL</code>	447
<code>[:SOURce<hw>]:BB:GNSS:SV:IMPorT:NAVic:EXECute</code>	447
<code>[:SOURce<hw>]:BB:GNSS:SV:IMPorT:QZSS:EXECute</code>	447
<code>[:SOURce<hw>]:BB:GNSS:SV:IMPorT:BEIDou:EXECute</code>	448
<code>[:SOURce<hw>]:BB:GNSS:SV:IMPorT:GLONass:EXECute</code>	448
<code>[:SOURce<hw>]:BB:GNSS:SV:IMPorT:GALileo:EXECute</code>	448
<code>[:SOURce<hw>]:BB:GNSS:SV:IMPorT:GPS:EXECute</code>	448

`[:SOURce<hw>]:BB:GNSS:SV:SELECTION:MODE <SelectionMode>`

Selects a criterium to define the initial satellite constellation.

Parameters:

<SelectionMode> MANual | ELEVation | VISibility | DOP | ADOP

MANual

Manual selection to add active space vehicles of the satellite constellation and remove inactive space vehicles from the satellite constellation. You can also activate invisible space vehicles.

ELEVation

Automatic selection of space vehicles according to their highest elevation angle.

VISibility

Automatic selection of space vehicles according to their longest visibility time.

DOP

Automatic selection with good dilution of precision (DOP) values at simulation start.

ADOP

Adaptive DOP mode providing automatic selection with good DOP values at simulation start and during runtime.

*RST: VISibility

Example: See [Example "Configuring the satellite's constellation"](#) on page 438.

Manual operation: See "[Selection Mode](#)" on page 78

`[:SOURce<hw>]:BB:GNSS:SV:SELECTION:EOBScuration:REFerence <Type>`

Selects how the behavior of earth obscuration is defined.

Parameters:

<Type> ETANgent | LHORizon
 *RST: ETANgent

Example:

See [Example"Configuring the satellite's constellation"](#) on page 438.

Manual operation:

See ["Earth Obscuration Reference \(Cut-Off Reference\)"](#) on page 79

[:SOURce<hw>]:BB:GNSS:SV:SELECTION:EOBScuration:ANGLE <ElevMaskAngle>

Sets the satellite's elevation mask angle. The angle is applied relative to the selected horizon.

Parameters:

<ElevMaskAngle> float
 Range: -10 to 90
 Increment: 0.1
 *RST: 5

Example:

See [Example"Configuring the satellite's constellation"](#) on page 438.

Manual operation:

See ["Earth Obscuration Offset \(Cut-Off Angle\)"](#) on page 81

[:SOURce<hw>]:BB:GNSS:SV:SELECTION:CHANNELS:MAX <MaxNumbChannels>

Queries the maximum number of GNSS channels.

The number depends on the simulation capacity, see [Chapter G, "Channel budget"](#), on page 682.

Parameters:

<MaxNumbChannels>integer
 Range: 6 to 612
 *RST: 24

Manual operation:

See ["Maximum Number of Channels/Total Number of Available Channels"](#) on page 81

[:SOURce<hw>]:BB:GNSS:SV:SELECTION:SBAS:MIN <MinimumSVs>
[:SOURce<hw>]:BB:GNSS:SV:SELECTION:SBAS:MAX <MaximumSVs>
[:SOURce<hw>]:BB:GNSS:SV:SELECTION:NAVIC:MIN <MinimumSVs>
[:SOURce<hw>]:BB:GNSS:SV:SELECTION:NAVIC:MAX <MaximumSVs>
[:SOURce<hw>]:BB:GNSS:SV:SELECTION:QZSS:MIN <MinimumSVs>
[:SOURce<hw>]:BB:GNSS:SV:SELECTION:QZSS:MAX <MaximumSVs>
[:SOURce<hw>]:BB:GNSS:SV:SELECTION:BEIDOU:MIN <MinimumSVs>
[:SOURce<hw>]:BB:GNSS:SV:SELECTION:BEIDOU:MAX <MaximumSVs>
[:SOURce<hw>]:BB:GNSS:SV:SELECTION:GLONASS:MIN <MinimumSVs>
[:SOURce<hw>]:BB:GNSS:SV:SELECTION:GLONASS:MAX <MaximumSVs>

```
[:SOURce<hw>]:BB:GNSS:SV:SElection:GALileo:MIN <MinimumSVs>
[:SOURce<hw>]:BB:GNSS:SV:SElection:GALileo:MAX <MaximumSVs>
[:SOURce<hw>]:BB:GNSS:SV:SElection:GPS:MIN <MinimumSVs>
[:SOURce<hw>]:BB:GNSS:SV:SElection:GPS:MAX <MaximumSVs>
```

Sets the minimum and maximum number of satellites per GNSS system that can be included in the satellite constellation.

Parameters:

<MaximumSVs> integer
 Range: 0 to 24
 *RST: 24

Example: See [Example"Configuring the satellite's constellation"](#) on page 438.

Manual operation: See ["Number of SVs"](#) on page 81

```
[:SOURce<hw>]:BB:GNSS:SV:SElection:SBAS:ACTive?
[:SOURce<hw>]:BB:GNSS:SV:SElection:NAVic:ACTive?
[:SOURce<hw>]:BB:GNSS:SV:SElection:QZSS:ACTive?
[:SOURce<hw>]:BB:GNSS:SV:SElection:BEIDou:ACTive?
[:SOURce<hw>]:BB:GNSS:SV:SElection:GLONass:ACTive?
[:SOURce<hw>]:BB:GNSS:SV:SElection:GALileo:ACTive?
[:SOURce<hw>]:BB:GNSS:SV:SElection:GPS:ACTive?
```

Queries the number of active satellites per GNSS system that are currently part of the satellite's constellation.

Return values:

<ActiveSVs> integer
 Range: 0 to 24
 *RST: 0

Example: See [Example"Configuring the satellite's constellation"](#) on page 438.

Usage: Query only

Manual operation: See ["Number of SVs"](#) on page 81

```
[:SOURce<hw>]:BB:GNSS:SV:SElection:SBAS:AVAIlable?
[:SOURce<hw>]:BB:GNSS:SV:SElection:NAVic:AVAIlable?
[:SOURce<hw>]:BB:GNSS:SV:SElection:QZSS:AVAIlable?
[:SOURce<hw>]:BB:GNSS:SV:SElection:BEIDou:AVAIlable?
[:SOURce<hw>]:BB:GNSS:SV:SElection:GLONass:AVAIlable?
[:SOURce<hw>]:BB:GNSS:SV:SElection:GALileo:AVAIlable?
[:SOURce<hw>]:BB:GNSS:SV:SElection:GPS:AVAIlable?
```

Queries the number of available satellites per GNSS system.

Return values:

<AvailableSVs> integer
 Range: 0 to 40
 *RST: 0

Example: See [Example"Configuring the satellite's constellation"](#) on page 438.

Usage: Query only

Manual operation: See ["Number of SVs"](#) on page 81

```
[:SOURce<hw>]:BB:GNSS:SVID:SBAS:LIST:ALL?
[:SOURce<hw>]:BB:GNSS:SVID:NAVic:LIST:ALL?
[:SOURce<hw>]:BB:GNSS:SVID:QZSS:LIST:ALL?
[:SOURce<hw>]:BB:GNSS:SVID:BEIDou:LIST:ALL?
[:SOURce<hw>]:BB:GNSS:SVID:GLONass:LIST:ALL?
[:SOURce<hw>]:BB:GNSS:SVID:GALileo:LIST:ALL?
[:SOURce<hw>]:BB:GNSS:SVID:GPS:LIST:ALL?
```

Queries the SV IDs of all satellites of the GNSS system.

The query lists SV IDs of the satellites included in and excluded from the satellite constellation ([Figure 6-1](#)).

Example: See [Example"Configuring the satellite's constellation"](#) on page 438.

Usage: Query only

Manual operation: See ["Satellite's Constellation, SV ID"](#) on page 75

```
[:SOURce<hw>]:BB:GNSS:SVID:SBAS:LIST[:VALid]?
[:SOURce<hw>]:BB:GNSS:SVID:NAVic:LIST[:VALid]?
[:SOURce<hw>]:BB:GNSS:SVID:QZSS:LIST[:VALid]?
[:SOURce<hw>]:BB:GNSS:SVID:BEIDou:LIST[:VALid]?
[:SOURce<hw>]:BB:GNSS:SVID:GLONass:LIST[:VALid]?
[:SOURce<hw>]:BB:GNSS:SVID:GALileo:LIST[:VALid]?
[:SOURce<hw>]:BB:GNSS:SVID:GPS:LIST[:VALid]?
```

Queries the SV IDs of all valid satellites for the GNSS system.

The query lists SV IDs of the satellites included in the satellite constellation.

Example: See [Example"Configuring the satellite's constellation"](#) on page 438.

Usage: Query only

Manual operation: See ["Satellite's Constellation, SV ID"](#) on page 75

```
[:SOURce<hw>]:BB:GNSS:SVID<ch>:SBAS:HEALTHy <HealthyState>
[:SOURce<hw>]:BB:GNSS:SVID<ch>:NAVic:HEALTHy <HealthyState>
[:SOURce<hw>]:BB:GNSS:SVID<ch>:QZSS:HEALTHy <HealthyState>
```

```
[ :SOURce<hw>]:BB:GNSS:SVID<ch>:BEIDou:HEALthy <HealthyState>
[:SOURce<hw>]:BB:GNSS:SVID<ch>:GLONass:HEALthy <HealthyState>
[:SOURce<hw>]:BB:GNSS:SVID<ch>:GALileo:HEALthy <HealthyState>
[:SOURce<hw>]:BB:GNSS:SVID<ch>:GPS:HEALthy <HealthyState>
```

Indicates if the selected SV ID is healthy or not.

Parameters:

<HealthyState> 1 | ON | 0 | OFF

1 = healthy satellite

The healthy state reflects the value of the corresponding healthy flag in the navigation message:

[\[:SOURce<hw>\]:BB:GNSS:SVID<ch>:GPS:NMESSage:LNAV:EPHemeris:HEALth](#) on page 547

[\[:SOURce<hw>\]:BB:GNSS:SVID<ch>:GPS:NMESSage:CNAV:EPHemeris:L1Health](#) on page 545

[\[:SOURce<hw>\]:BB:GNSS:SVID<ch>:GPS:NMESSage:CNAV:EPHemeris:L2Health](#) on page 545

[\[:SOURce<hw>\]:BB:GNSS:SVID<ch>:GPS:NMESSage:CNAV:EPHemeris:L5Health](#) on page 545

[\[:SOURce<hw>\]:BB:GNSS:SVID<ch>:GALileo:NMESSage:INAV:E1BDVS](#) on page 550

[\[:SOURce<hw>\]:BB:GNSS:SVID<ch>:GALileo:NMESSage:INAV:E1BHS](#) on page 550

[\[:SOURce<hw>\]:BB:GNSS:SVID<ch>:GALileo:NMESSage:INAV:E5BHS](#) on page 550

[\[:SOURce<hw>\]:BB:GNSS:SVID<ch>:BEIDou:NMESSage:DNAV:EPHemeris:HEALth](#) on page 547

[\[:SOURce<hw>\]:BB:GNSS:SVID<ch>:GLONass:NMESSage:NAV:EPHemeris:HEALth](#) on page 547

[\[:SOURce<hw>\]:BB:GNSS:SVID<ch>:QZSS:NMESSage:NAV:EPHemeris:HEALth](#) on page 547

The values are interdependent; changing one of them changes the other.

```
*RST: 1
```

Example: See [Example "Configuring the satellite's constellation"](#) on page 438.

Example:

```
SOURce1:BB:GNSS:SVID1:GPS:NMESSage:LNAV:EPHemeris:HEALth 0
SOURce1:BB:GNSS:SVID1:GPS:HEALthy?
// 1
SOURce1:BB:GNSS:SVID1:GPS:HEALthy 0
SOURce1:BB:GNSS:SVID1:GPS:NMESSage:LNAV:EPHemeris:HEALth?
// 63
```

Manual operation: See ["Satellite's Constellation, SV ID"](#) on page 75
See ["Healthy"](#) on page 86

```
[:SOURce<hw>]:BB:GNSS:SVID<ch>:SBAS:VISibility:STATe?
[:SOURce<hw>]:BB:GNSS:SVID<ch>:NAVic:VISibility:STATe?
[:SOURce<hw>]:BB:GNSS:SVID<ch>:QZSS:VISibility:STATe?
[:SOURce<hw>]:BB:GNSS:SVID<ch>:BEIDou:VISibility:STATe?
[:SOURce<hw>]:BB:GNSS:SVID<ch>:GLONass:VISibility:STATe?
[:SOURce<hw>]:BB:GNSS:SVID<ch>:GALileo:VISibility:STATe?
[:SOURce<hw>]:BB:GNSS:SVID<ch>:GPS:VISibility:STATe?
```

Queries if the selected SV ID is visible in the satellite constellation.

Return values:

```
<VisibilityState>    1 | ON | 0 | OFF
                    *RST:    0
```

Example: See [Example "Configuring the satellite's constellation"](#) on page 438.

Usage: Query only

Manual operation: See ["Satellite's Constellation, SV ID"](#) on page 75

```
[:SOURce<hw>]:BB:GNSS:SV:IMPort:NAVic:FILE:CONStellation <Filename>
[:SOURce<hw>]:BB:GNSS:SV:IMPort:QZSS:FILE:CONStellation <Filename>
[:SOURce<hw>]:BB:GNSS:SV:IMPort:BEIDou:FILE:CONStellation <Filename>
[:SOURce<hw>]:BB:GNSS:SV:IMPort:GLONass:FILE:CONStellation <Filename>
[:SOURce<hw>]:BB:GNSS:SV:IMPort:GALileo:FILE:CONStellation <Filename>
[:SOURce<hw>]:BB:GNSS:SV:IMPort:GPS:FILE:CONStellation <Filename>
```

Selects the file from that the satellites constellation and navigation data are extracted.

Table 22-1: Supported file extensions for satellites constellation and navigation data

GNSS	File extension
GPS	*.rnx, *.txt, *.alm, *.al3, *.<xx>n,
Galileo	*.rnx, *.txt, *.alm, *.al3, *.<xx>n, *.<xx>l, *.xml
GLONASS	*.rnx, *.alg, *.<xx>n
BeiDou	*.rnx, *.txt, *.<xx>n, *.<xx>c
QZSS	*.rnx, *.txt, *.alm, *.<xx>n,
NavIC	*.rnx, *.<xx>i

Parameters:

```
<Filename>          string
                    Filename, including file path and file extension.
```

Example: See [Example "Importing a satellite constellation"](#) on page 439.

Manual operation: See ["Constellation Source File"](#) on page 311

```
[:SOURce<hw>]:BB:GNSS:SV:IMPort:NAVic:UDSource <UseDiffSrcState>
[:SOURce<hw>]:BB:GNSS:SV:IMPort:QZSS:UDSource <UseDiffSrcState>
[:SOURce<hw>]:BB:GNSS:SV:IMPort:BEIDou:UDSource <UseDiffSrcState>
[:SOURce<hw>]:BB:GNSS:SV:IMPort:GLONass:UDSource <UseDiffSrcState>
[:SOURce<hw>]:BB:GNSS:SV:IMPort:GALileo:UDSource <UseDiffSrcState>
[:SOURce<hw>]:BB:GNSS:SV:IMPort:GPS:UDSource <UseDiffSrcState>
```

Enables loading the dedicated files as source for the navigation data.

Parameters:

```
<UseDiffSrcState> 1 | ON | 0 | OFF
*RST: 0
```

Example: See [Example"Importing a satellite constellation"](#) on page 439.

Manual operation: See ["Use Different Source File for Navigation Message"](#) on page 311

```
[:SOURce<hw>]:BB:GNSS:SV:IMPort:NAVic:FILE:NMESSage <Filename>
[:SOURce<hw>]:BB:GNSS:SV:IMPort:QZSS:FILE:NMESSage <Filename>
[:SOURce<hw>]:BB:GNSS:SV:IMPort:BEIDou:FILE:NMESSage <Filename>
[:SOURce<hw>]:BB:GNSS:SV:IMPort:GLONass:FILE:NMESSage <Filename>
[:SOURce<hw>]:BB:GNSS:SV:IMPort:GALileo:FILE:NMESSage <Filename>
[:SOURce<hw>]:BB:GNSS:SV:IMPort:GPS:FILE:NMESSage <Filename>
```

Selects the file from that the navigation data is extracted.

For an overview of the supported file types, see [Table 22-1](#).

Parameters:

```
<Filename> string
Filename, incl. file path and file extension.
```

Example: See [Example"Importing a satellite constellation"](#) on page 439.

Manual operation: See ["Navigation Message Source File"](#) on page 311
See ["Use Constellation Source File for all active GNSS system"](#) on page 311

```
[:SOURce<hw>]:BB:GNSS:SV:IMPort:BEIDou:UALL <UseToAllSystems>
[:SOURce<hw>]:BB:GNSS:SV:IMPort:GALileo:UALL <UseToAllSystems>
[:SOURce<hw>]:BB:GNSS:SV:IMPort:GLONass:UALL <UseToAllSystems>
[:SOURce<hw>]:BB:GNSS:SV:IMPort:GPS:UALL <UseToAllSystems>
[:SOURce<hw>]:BB:GNSS:SV:IMPort:NAVic:UALL <UseToAllSystems>
[:SOURce<hw>]:BB:GNSS:SV:IMPort:QZSS:UALL <UseToAllSystems>
```

Parameters:

```
<UseToAllSystems> 1 | ON | 0 | OFF
*RST: 0
```

```
[:SOURce<hw>]:BB:GNSS:SV:IMPort:NAVic:EXECute
[:SOURce<hw>]:BB:GNSS:SV:IMPort:QZSS:EXECute
```

```
[:SOURce<hw>]:BB:GNSS:SV:IMPorT:BEIDou:EXECute
[:SOURce<hw>]:BB:GNSS:SV:IMPorT:GLONass:EXECute
[:SOURce<hw>]:BB:GNSS:SV:IMPorT:GALileo:EXECute
[:SOURce<hw>]:BB:GNSS:SV:IMPorT:GPS:EXECute
```

Triggers the import of constellation and navigation data from the selected files.

Example: See [Example "Importing a satellite constellation"](#) on page 439.

Usage: Event

Manual operation: See ["Import, Cancel"](#) on page 311

22.12 Signals and power configuration per satellite

Example: To configure SV power and modulation control

```
SOURcel:BB:GNSS:PRESet
SOURcel:BB:GNSS:TMODe NAV
// Activate C/A and P codes in L1 band.
SOURcel:BB:GNSS:SYSTem:GPS:SIGNal:L1Band:CA:STATe 1
SOURcel:BB:GNSS:SYSTem:GPS:SIGNal:L1Band:P:STATe 1
SOURcel:BB:GNSS:SYSTem:GPS:SIGNal:L1Band:L1C:STATe 0
// Activate GPS SVID#1.
SOURcel:BB:GNSS:SVID1:GPS:STATe 1
SOURcel:BB:GNSS:SVID1:GPS:PRESet 1

// Set power-related settings.
SOURcel:BB:GNSS:POWer:REFerence -120
SOURcel:BB:GNSS:SVID1:GPS:POWer:PLOsS 1
SOURcel:BB:GNSS:SVID1:GPS:POWer:OFFSet -3
SOURcel:BB:GNSS:SVID1:GPS:SIGNal:L1Band:CA:POWer:OFFset 0
SOURcel:BB:GNSS:SVID1:GPS:SIGNal:L1Band:P:POWer:OFFset -3
// Apply the settings to SVID#11.
SOURcel:BB:GNSS:SVID1:GPS:POWer:COpy:SVID 11
SOURcel:BB:GNSS:SVID1:GPS:POWer:COpy:EXECute

// Set the modulation control settings.
SOURcel:BB:GNSS:SVID1:GPS:SIGNal:L1Band:CA:DATA:PCODE:STATe 1
SOURcel:BB:GNSS:SVID1:GPS:SIGNal:L1Band:P:DATA:PCODE:STATe 1
SOURcel:BB:GNSS:SVID1:GPS:SIGNal:L1Band:CA:DATA:NMESsage:CONTRol AUTO
SOURcel:BB:GNSS:SVID1:GPS:SIGNal:L1Band:CA:DATA:NMESsage:TYPE RND
SOURcel:BB:GNSS:SVID1:GPS:MCONTRol:COpy:SVID 5
SOURcel:BB:GNSS:SVID1:GPS:MCONTRol:COpy:EXECute
```

Example: To load a Galileo OSNMA scenario

Load a predefined Galileo OSNMA scenario and check Galileo signal and satellite characteristics.

Signals and power configuration per satellite

```

// Load a scenario, for example, the scenario 'OSNMA: Configuration A'.
SOURCE1:BB:GNSS:SETTING:LOAD:PREDEFINED "OSNMA: Configuration A"
SOURCE1:BB:GNSS:SCENARIO?
// Response: "OSNMA: Configuration A"
// Query simulation information.
SOURCE1:BB:GNSS:SIMULATION:INFO?
// Response: "L1 / Galileo only"

// Query signal and SV 2 information.
SOURCE1:BB:GNSS:SYSTEM:GALILEO:SIGNALL1BAND:E1OS:STATE?
// Response: "1"
SOURCE1:BB:GNSS:SVID2:GALILEO:STATE?
// Response: "1"
SOURCE1:BB:GNSS:SVID2:GALILEO:POWER:OFFSET?
// Response in dB: "0"

// Query navigation message data and OSNMA state.
SOURCE1:BB:GNSS:SVID2:GALILEO:SIGNALL1BAND:E1OS:DATA:NMESSAGE:DSELECT?
// Response: "/opt/data/Lists/Gnss/Predefined/OSNMA/
// osnma_test_vectors/configuration_A/confA_Sat02.dm_iqd"
SOURCE1:BB:GNSS:SVID2:GALILEO:SIGNALL1BAND:E1OS:DATA:OSNMA:STATE?
// Response: "1"

// Activate GNSS and check signal characteristics of the RF output signal.
SOURCE1:BB:GNSS:STATE 1
SOURCE1:FREQUENCY:CW?
// Response in Hz: "1575420000"
SOURCE1:POWER:PEP?
// Response in dB: "-77.35"
SOURCE1:POWER:LEVEL:IMMEDIATE:AMPLITUDE?
// Response in dB: "-80.36"
OUTPUT1:STATE 1

```

Commands:

[:SOURCE<hw>]:BB:GNSS:SVID<ch>:SBAS:STATE	458
[:SOURCE<hw>]:BB:GNSS:SVID<ch>:NAVIC:STATE	458
[:SOURCE<hw>]:BB:GNSS:SVID<ch>:QZSS:STATE	458
[:SOURCE<hw>]:BB:GNSS:SVID<ch>:BEIDOU:STATE	458
[:SOURCE<hw>]:BB:GNSS:SVID<ch>:GLONASS:STATE	458
[:SOURCE<hw>]:BB:GNSS:SVID<ch>:GALILEO:STATE	459
[:SOURCE<hw>]:BB:GNSS:SVID<ch>:GPS:STATE	459
[:SOURCE<hw>]:BB:GNSS:SVID<ch>:SBAS:PRESENT	459
[:SOURCE<hw>]:BB:GNSS:SVID<ch>:NAVIC:PRESENT	459
[:SOURCE<hw>]:BB:GNSS:SVID<ch>:QZSS:PRESENT	459
[:SOURCE<hw>]:BB:GNSS:SVID<ch>:BEIDOU:PRESENT	459
[:SOURCE<hw>]:BB:GNSS:SVID<ch>:GLONASS:PRESENT	459
[:SOURCE<hw>]:BB:GNSS:SVID<ch>:GALILEO:PRESENT	459
[:SOURCE<hw>]:BB:GNSS:SVID<ch>:GPS:PRESENT	459
[:SOURCE<hw>]:BB:GNSS:SVID<ch>:GLONASS:FNUMBER	459
[:SOURCE<hw>]:BB:GNSS:POWER:REFERENCE	459
[:SOURCE<hw>]:BB:GNSS:SVID<ch>:SBAS:POWER:PLOSS	460

Signals and power configuration per satellite

[:SOURce<hw>]:BB:GNSS:SVID<ch>:NAVic:POWer:PLOsS.....460

[:SOURce<hw>]:BB:GNSS:SVID<ch>:QZSS:POWer:PLOsS.....460

[:SOURce<hw>]:BB:GNSS:SVID<ch>:BEIDou:POWer:PLOsS.....460

[:SOURce<hw>]:BB:GNSS:SVID<ch>:GLONass:POWer:PLOsS.....460

[:SOURce<hw>]:BB:GNSS:SVID<ch>:GALileo:POWer:PLOsS.....460

[:SOURce<hw>]:BB:GNSS:SVID<ch>:GPS:POWer:PLOsS.....460

[:SOURce<hw>]:BB:GNSS:SVID<ch>:SBAS:POWer:OFFSet.....460

[:SOURce<hw>]:BB:GNSS:SVID<ch>:NAVic:POWer:OFFSet.....460

[:SOURce<hw>]:BB:GNSS:SVID<ch>:QZSS:POWer:OFFSet.....460

[:SOURce<hw>]:BB:GNSS:SVID<ch>:BEIDou:POWer:OFFSet.....460

[:SOURce<hw>]:BB:GNSS:SVID<ch>:GLONass:POWer:OFFSet.....460

[:SOURce<hw>]:BB:GNSS:SVID<ch>:GALileo:POWer:OFFSet.....460

[:SOURce<hw>]:BB:GNSS:SVID<ch>:GPS:POWer:OFFSet.....460

[:SOURce<hw>]:BB:GNSS:SVID<ch>:SBAS:SIGNal:L5Band:EL5S:POWer:OFFset.....461

[:SOURce<hw>]:BB:GNSS:SVID<ch>:SBAS:SIGNal:L1Band:CA:POWer:OFFset.....461

[:SOURce<hw>]:BB:GNSS:SVID<ch>:NAVic:SIGNal:L5Band:SPS:POWer:OFFset.....461

[:SOURce<hw>]:BB:GNSS:SVID<ch>:QZSS:SIGNal:L5Band:L5S:POWer:OFFset.....461

[:SOURce<hw>]:BB:GNSS:SVID<ch>:QZSS:SIGNal:L2Band:L2C:POWer:OFFset.....461

[:SOURce<hw>]:BB:GNSS:SVID<ch>:QZSS:SIGNal:L1Band:L1C:POWer:OFFset.....461

[:SOURce<hw>]:BB:GNSS:SVID<ch>:QZSS:SIGNal:L1Band:CA:POWer:OFFset.....461

[:SOURce<hw>]:BB:GNSS:SVID<ch>:BEIDou:SIGNal:L5Band:B2I:POWer:OFFset.....461

[:SOURce<hw>]:BB:GNSS:SVID<ch>:BEIDou:SIGNal:L5Band:B2B:POWer:OFFset.....461

[:SOURce<hw>]:BB:GNSS:SVID<ch>:BEIDou:SIGNal:L5Band:B2A:POWer:OFFset.....461

[:SOURce<hw>]:BB:GNSS:SVID<ch>:BEIDou:SIGNal:L2Band:B3I:POWer:OFFset.....461

[:SOURce<hw>]:BB:GNSS:SVID<ch>:BEIDou:SIGNal:L1Band:B1I:POWer:OFFset.....461

[:SOURce<hw>]:BB:GNSS:SVID<ch>:BEIDou:SIGNal:L1Band:B1C:POWer:OFFset.....461

[:SOURce<hw>]:BB:GNSS:SVID<ch>:GLONass:SIGNal:L5Band:L3CDma:POWer:OFFset...461

[:SOURce<hw>]:BB:GNSS:SVID<ch>:GLONass:SIGNal:L2Band:L2CDma:POWer:OFFset...461

[:SOURce<hw>]:BB:GNSS:SVID<ch>:GLONass:SIGNal:L2Band:CA:POWer:OFFset.....461

[:SOURce<hw>]:BB:GNSS:SVID<ch>:GLONass:SIGNal:L1Band:L1CDma:POWer:OFFset...461

[:SOURce<hw>]:BB:GNSS:SVID<ch>:GLONass:SIGNal:L1Band:CA:POWer:OFFset.....461

[:SOURce<hw>]:BB:GNSS:SVID<ch>:GALileo:SIGNal:L5Band:E5B:POWer:OFFset.....461

[:SOURce<hw>]:BB:GNSS:SVID<ch>:GALileo:SIGNal:L5Band:E5A:POWer:OFFset.....461

[:SOURce<hw>]:BB:GNSS:SVID<ch>:GALileo:SIGNal:L2Band:E6PRs:POWer:OFFset.....461

[:SOURce<hw>]:BB:GNSS:SVID<ch>:GALileo:SIGNal:L2Band:E6S:POWer:OFFset.....461

[:SOURce<hw>]:BB:GNSS:SVID<ch>:GALileo:SIGNal:L1Band:E1OS:POWer:OFFset.....461

[:SOURce<hw>]:BB:GNSS:SVID<ch>:GALileo:SIGNal:L1Band:E1PRs:POWer:OFFset.....461

[:SOURce<hw>]:BB:GNSS:SVID<ch>:GPS:SIGNal:L5Band:L5S:POWer:OFFset.....462

[:SOURce<hw>]:BB:GNSS:SVID<ch>:GPS:SIGNal:L2Band:L2C:POWer:OFFset.....462

[:SOURce<hw>]:BB:GNSS:SVID<ch>:GPS:SIGNal:L2Band:M:POWer:OFFset.....462

[:SOURce<hw>]:BB:GNSS:SVID<ch>:GPS:SIGNal:L2Band:P:POWer:OFFset.....462

[:SOURce<hw>]:BB:GNSS:SVID<ch>:GPS:SIGNal:L2Band:PY:POWer:OFFset.....462

[:SOURce<hw>]:BB:GNSS:SVID<ch>:GPS:SIGNal:L2Band:CA:POWer:OFFset.....462

[:SOURce<hw>]:BB:GNSS:SVID<ch>:GPS:SIGNal:L1Band:L1C:POWer:OFFset.....462

[:SOURce<hw>]:BB:GNSS:SVID<ch>:GPS:SIGNal:L1Band:M:POWer:OFFset.....462

[:SOURce<hw>]:BB:GNSS:SVID<ch>:GPS:SIGNal:L1Band:P:POWer:OFFset.....462

[:SOURce<hw>]:BB:GNSS:SVID<ch>:GPS:SIGNal:L1Band:PY:POWer:OFFset.....462

[:SOURce<hw>]:BB:GNSS:SVID<ch>:GPS:SIGNal:L1Band:CA:POWer:OFFset.....462

[:SOURce<hw>]:BB:GNSS:SVID<ch>:SBAS:POWer:COPIY:SVID.....462

[:SOURce<hw>]:BB:GNSS:SVID<ch>:NAVic:POWer:COPIY:SVID.....462

Signals and power configuration per satellite

[SOURce<hw>]:BB:GNSS:SVID<ch>:QZSS:POWer:COPIY:SVID.....	462
[SOURce<hw>]:BB:GNSS:SVID<ch>:BEIDou:POWer:COPIY:SVID.....	462
[SOURce<hw>]:BB:GNSS:SVID<ch>:GLONass:POWer:COPIY:SVID.....	462
[SOURce<hw>]:BB:GNSS:SVID<ch>:GALileo:POWer:COPIY:SVID.....	462
[SOURce<hw>]:BB:GNSS:SVID<ch>:GPS:POWer:COPIY:SVID.....	462
[SOURce<hw>]:BB:GNSS:SVID<ch>:SBAS:POWer:COPIY:EXECute.....	463
[SOURce<hw>]:BB:GNSS:SVID<ch>:NAVic:POWer:COPIY:EXECute.....	463
[SOURce<hw>]:BB:GNSS:SVID<ch>:QZSS:POWer:COPIY:EXECute.....	463
[SOURce<hw>]:BB:GNSS:SVID<ch>:BEIDou:POWer:COPIY:EXECute.....	463
[SOURce<hw>]:BB:GNSS:SVID<ch>:GLONass:POWer:COPIY:EXECute.....	463
[SOURce<hw>]:BB:GNSS:SVID<ch>:GALileo:POWer:COPIY:EXECute.....	463
[SOURce<hw>]:BB:GNSS:SVID<ch>:GPS:POWer:COPIY:EXECute.....	463
[SOURce<hw>]:BB:GNSS:SVID<ch>:SBAS:SIGNal:L5Band:EL5S[:STATe].....	463
[SOURce<hw>]:BB:GNSS:SVID<ch>:SBAS:SIGNal:L1Band:CA[:STATe].....	463
[SOURce<hw>]:BB:GNSS:SVID<ch>:NAVic:SIGNal:L5Band:SPS[:STATe].....	463
[SOURce<hw>]:BB:GNSS:SVID<ch>:QZSS:SIGNal:L5Band:L5S[:STATe].....	463
[SOURce<hw>]:BB:GNSS:SVID<ch>:QZSS:SIGNal:L2Band:L2C[:STATe].....	464
[SOURce<hw>]:BB:GNSS:SVID<ch>:QZSS:SIGNal:L1Band:L1C[:STATe].....	464
[SOURce<hw>]:BB:GNSS:SVID<ch>:QZSS:SIGNal:L1Band:CA[:STATe].....	464
[SOURce<hw>]:BB:GNSS:SVID<ch>:BEIDou:SIGNal:L5Band:B2I[:STATe].....	464
[SOURce<hw>]:BB:GNSS:SVID<ch>:BEIDou:SIGNal:L5Band:B2A[:STATe].....	464
[SOURce<hw>]:BB:GNSS:SVID<ch>:BEIDou:SIGNal:L5Band:B2B[:STATe].....	464
[SOURce<hw>]:BB:GNSS:SVID<ch>:BEIDou:SIGNal:L2Band:B3I[:STATe].....	464
[SOURce<hw>]:BB:GNSS:SVID<ch>:BEIDou:SIGNal:L1Band:B1I[:STATe].....	464
[SOURce<hw>]:BB:GNSS:SVID<ch>:BEIDou:SIGNal:L1Band:B1C[:STATe].....	464
[SOURce<hw>]:BB:GNSS:SVID<ch>:GLONass:SIGNal:L5Band:L3CDma[:STATe].....	464
[SOURce<hw>]:BB:GNSS:SVID<ch>:GLONass:SIGNal:L2Band:L2CDma[:STATe].....	464
[SOURce<hw>]:BB:GNSS:SVID<ch>:GLONass:SIGNal:L2Band:CA[:STATe].....	464
[SOURce<hw>]:BB:GNSS:SVID<ch>:GLONass:SIGNal:L1Band:L1CDma[:STATe].....	464
[SOURce<hw>]:BB:GNSS:SVID<ch>:GALileo:SIGNal:L5Band:E5B[:STATe].....	464
[SOURce<hw>]:BB:GNSS:SVID<ch>:GALileo:SIGNal:L5Band:E5A[:STATe].....	464
[SOURce<hw>]:BB:GNSS:SVID<ch>:GALileo:SIGNal:L2Band:E6PRs[:STATe].....	464
[SOURce<hw>]:BB:GNSS:SVID<ch>:GALileo:SIGNal:L2Band:E6S[:STATe].....	464
[SOURce<hw>]:BB:GNSS:SVID<ch>:GALileo:SIGNal:L1Band:E1OS[:STATe].....	464
[SOURce<hw>]:BB:GNSS:SVID<ch>:GALileo:SIGNal:L1Band:E1PRs[:STATe].....	464
[SOURce<hw>]:BB:GNSS:SVID<ch>:GPS:SIGNal:L5Band:L5S[:STATe].....	464
[SOURce<hw>]:BB:GNSS:SVID<ch>:GPS:SIGNal:L2Band:CA[:STATe].....	464
[SOURce<hw>]:BB:GNSS:SVID<ch>:GPS:SIGNal:L2Band:L2C[:STATe].....	464
[SOURce<hw>]:BB:GNSS:SVID<ch>:GPS:SIGNal:L2Band:M[:STATe].....	464
[SOURce<hw>]:BB:GNSS:SVID<ch>:GPS:SIGNal:L2Band:P[:STATe].....	464
[SOURce<hw>]:BB:GNSS:SVID<ch>:GPS:SIGNal:L2Band:PY[:STATe].....	464
[SOURce<hw>]:BB:GNSS:SVID<ch>:GPS:SIGNal:L1Band:L1C[:STATe].....	464
[SOURce<hw>]:BB:GNSS:SVID<ch>:GPS:SIGNal:L1Band:M[:STATe].....	464
[SOURce<hw>]:BB:GNSS:SVID<ch>:GPS:SIGNal:L1Band:P[:STATe].....	464
[SOURce<hw>]:BB:GNSS:SVID<ch>:GPS:SIGNal:L1Band:PY[:STATe].....	464
[SOURce<hw>]:BB:GNSS:SVID<ch>:GPS:SIGNal:L1Band:CA[:STATe].....	464
[SOURce<hw>]:BB:GNSS:SVID<ch>:SBAS:SIGNal:L5Band:EL5S:DATA:PCODE[:STATe].....	465
[SOURce<hw>]:BB:GNSS:SVID<ch>:SBAS:SIGNal:L1Band:CA:DATA:PCODE[:STATe].....	465
[SOURce<hw>]:BB:GNSS:SVID<ch>:NAVic:SIGNal:L5Band:SPS:DATA:PCODE[:STATe].....	465
[SOURce<hw>]:BB:GNSS:SVID<ch>:QZSS:SIGNal:L5Band:L5S:DATA:PCODE[:STATe].....	465

Signals and power configuration per satellite

[:SOURce<hw>]:BB:GNSS:SVID<ch>:QZSS:SIGNal:L5Band:L5S:PILot:PCODEf[:STATe].....465

[:SOURce<hw>]:BB:GNSS:SVID<ch>:QZSS:SIGNal:L2Band:L2C:DATA:PCODEf[:STATe].....465

[:SOURce<hw>]:BB:GNSS:SVID<ch>:QZSS:SIGNal:L2Band:L2C:PILot:PCODEf[:STATe].....465

[:SOURce<hw>]:BB:GNSS:SVID<ch>:QZSS:SIGNal:L1Band:L1C:DATA:PCODEf[:STATe].....465

[:SOURce<hw>]:BB:GNSS:SVID<ch>:QZSS:SIGNal:L1Band:L1C:PILot:PCODEf[:STATe].....465

[:SOURce<hw>]:BB:GNSS:SVID<ch>:QZSS:SIGNal:L1Band:CA:DATA:PCODEf[:STATe].....465

[:SOURce<hw>]:BB:GNSS:SVID<ch>:QZSS:SIGNal:L1Band:CA:PILot:PCODEf[:STATe].....465

[:SOURce<hw>]:BB:GNSS:SVID<ch>:BEIDou:SIGNal:L5Band:B2I:DATA:PCODEf[:STATe]...465

[:SOURce<hw>]:BB:GNSS:SVID<ch>:BEIDou:SIGNal:L5Band:B2A:DATA:PCODEf[:STATe]..465

[:SOURce<hw>]:BB:GNSS:SVID<ch>:BEIDou:SIGNal:L5Band:B2A:PILot:PCODEf[:STATe]...465

[:SOURce<hw>]:BB:GNSS:SVID<ch>:BEIDou:SIGNal:L5Band:B2B:DATA:PCODEf[:STATe]..465

[:SOURce<hw>]:BB:GNSS:SVID<ch>:BEIDou:SIGNal:L2Band:B3I:DATA:PCODEf[:STATe]...465

[:SOURce<hw>]:BB:GNSS:SVID<ch>:BEIDou:SIGNal:L1Band:B1C:PILot:PCODEf[:STATe]...465

[:SOURce<hw>]:BB:GNSS:SVID<ch>:BEIDou:SIGNal:L1Band:B1I:DATA:PCODEf[:STATe]...465

[:SOURce<hw>]:BB:GNSS:SVID<ch>:BEIDou:SIGNal:L1Band:B1I:PILot:PCODEf[:STATe]....465

[:SOURce<hw>]:BB:GNSS:SVID<ch>:BEIDou:SIGNal:L1Band:B1C:DATA:PCODEf[:STATe]..465

[:SOURce<hw>]:BB:GNSS:SVID<ch>:GLONass:SIGNal:L5Band:L3CDma:DATA:PCODEf[:STATe].....466

[:SOURce<hw>]:BB:GNSS:SVID<ch>:GLONass:SIGNal:L5Band:L3CDma:PILot:PCODEf[:STATe].....466

[:SOURce<hw>]:BB:GNSS:SVID<ch>:GLONass:SIGNal:L2Band:L2CDma:PILot:PCODEf[:STATe].....466

[:SOURce<hw>]:BB:GNSS:SVID<ch>:GLONass:SIGNal:L2Band:CA:DATA:PCODEf[:STATe].466

[:SOURce<hw>]:BB:GNSS:SVID<ch>:GLONass:SIGNal:L2Band:CA:PILot:PCODEf[:STATe].466

[:SOURce<hw>]:BB:GNSS:SVID<ch>:GLONass:SIGNal:L1Band:L1CDma:DATA:PCODEf[:STATe].....466

[:SOURce<hw>]:BB:GNSS:SVID<ch>:GLONass:SIGNal:L1Band:L1CDma:PILot:PCODEf[:STATe].....466

[:SOURce<hw>]:BB:GNSS:SVID<ch>:GLONass:SIGNal:L1Band:CA:DATA:PCODEf[:STATe].466

[:SOURce<hw>]:BB:GNSS:SVID<ch>:GLONass:SIGNal:L1Band:CA:PILot:PCODEf[:STATe].466

[:SOURce<hw>]:BB:GNSS:SVID<ch>:GALileo:SIGNal:L5Band:E5B:DATA:PCODEf[:STATe]..466

[:SOURce<hw>]:BB:GNSS:SVID<ch>:GALileo:SIGNal:L5Band:E5B:PILot:PCODEf[:STATe]...466

[:SOURce<hw>]:BB:GNSS:SVID<ch>:GALileo:SIGNal:L5Band:E5A:DATA:PCODEf[:STATe]..466

[:SOURce<hw>]:BB:GNSS:SVID<ch>:GALileo:SIGNal:L5Band:E5A:PILot:PCODEf[:STATe]...466

[:SOURce<hw>]:BB:GNSS:SVID<ch>:GALileo:SIGNal:L2Band:E6PRs:DATA:PCODEf[:STATe].....466

[:SOURce<hw>]:BB:GNSS:SVID<ch>:GALileo:SIGNal:L2Band:E6S:DATA:PCODEf[:STATe]..466

[:SOURce<hw>]:BB:GNSS:SVID<ch>:GALileo:SIGNal:L2Band:E6S:PILot:PCODEf[:STATe]...466

[:SOURce<hw>]:BB:GNSS:SVID<ch>:GALileo:SIGNal:L1Band:E1OS:DATA:PCODEf[:STATe].....466

[:SOURce<hw>]:BB:GNSS:SVID<ch>:GALileo:SIGNal:L1Band:E1OS:PILot:PCODEf[:STATe]466

[:SOURce<hw>]:BB:GNSS:SVID<ch>:GALileo:SIGNal:L1Band:E1PRs:DATA:PCODEf[:STATe].....466

[:SOURce<hw>]:BB:GNSS:SVID<ch>:GPS:SIGNal:L5Band:L5S:DATA:PCODEf[:STATe].....466

[:SOURce<hw>]:BB:GNSS:SVID<ch>:GPS:SIGNal:L5Band:L5S:PILot:PCODEf[:STATe].....466

[:SOURce<hw>]:BB:GNSS:SVID<ch>:GPS:SIGNal:L2Band:CA:DATA:PCODEf[:STATe].....466

[:SOURce<hw>]:BB:GNSS:SVID<ch>:GPS:SIGNal:L2Band:CA:PILot:PCODEf[:STATe].....466

[:SOURce<hw>]:BB:GNSS:SVID<ch>:GPS:SIGNal:L2Band:L2C:DATA:PCODEf[:STATe].....466

[:SOURce<hw>]:BB:GNSS:SVID<ch>:GPS:SIGNal:L2Band:L2C:PILot:PCODEf[:STATe].....466

[:SOURce<hw>]:BB:GNSS:SVID<ch>:GPS:SIGNal:L2Band:M:DATA:PCODEf[:STATe].....467

Signals and power configuration per satellite

[SOURce<hw>]:BB:GNSS:SVID<ch>:GPS:SIGNal:L2Band:P:DATA:PCODE[:STATe].....	467
[SOURce<hw>]:BB:GNSS:SVID<ch>:GPS:SIGNal:L2Band:P:PILot:PCODE[:STATe].....	467
[SOURce<hw>]:BB:GNSS:SVID<ch>:GPS:SIGNal:L2Band:PY:DATA:PCODE[:STATe].....	467
[SOURce<hw>]:BB:GNSS:SVID<ch>:GPS:SIGNal:L1Band:L1C:DATA:PCODE[:STATe].....	467
[SOURce<hw>]:BB:GNSS:SVID<ch>:GPS:SIGNal:L1Band:L1C:PILot:PCODE[:STATe].....	467
[SOURce<hw>]:BB:GNSS:SVID<ch>:GPS:SIGNal:L1Band:M:DATA:PCODE[:STATe].....	467
[SOURce<hw>]:BB:GNSS:SVID<ch>:GPS:SIGNal:L1Band:P:DATA:PCODE[:STATe].....	467
[SOURce<hw>]:BB:GNSS:SVID<ch>:GPS:SIGNal:L1Band:P:PILot:PCODE[:STATe].....	467
[SOURce<hw>]:BB:GNSS:SVID<ch>:GPS:SIGNal:L1Band:PY:DATA:PCODE[:STATe].....	467
[SOURce<hw>]:BB:GNSS:SVID<ch>:GPS:SIGNal:L1Band:CA:PILot:PCODE[:STATe].....	467
[SOURce<hw>]:BB:GNSS:SVID<ch>:GPS:SIGNal:L1Band:CA:DATA:PCODE[:STATe].....	467
[SOURce<hw>]:BB:GNSS:SVID<ch>:QZSS:SIGNal:L5Band:L5S:DATA:SCODE[:STATe].....	467
[SOURce<hw>]:BB:GNSS:SVID<ch>:QZSS:SIGNal:L5Band:L5S:PILot:SCODE[:STATe].....	467
[SOURce<hw>]:BB:GNSS:SVID<ch>:QZSS:SIGNal:L1Band:L1C:PILot:SCODE[:STATe].....	467
[SOURce<hw>]:BB:GNSS:SVID<ch>:BEIDou:SIGNal:L5Band:B2A:DATA:SCODE[:STATe].....	467
[SOURce<hw>]:BB:GNSS:SVID<ch>:BEIDou:SIGNal:L5Band:B2A:PILot:SCODE[:STATe].....	467
[SOURce<hw>]:BB:GNSS:SVID<ch>:BEIDou:SIGNal:L5Band:B2I:DATA:SCODE[:STATe].....	467
[SOURce<hw>]:BB:GNSS:SVID<ch>:BEIDou:SIGNal:L2Band:B3I:DATA:SCODE[:STATe].....	467
[SOURce<hw>]:BB:GNSS:SVID<ch>:BEIDou:SIGNal:L1Band:B1C:PILot:SCODE[:STATe].....	468
[SOURce<hw>]:BB:GNSS:SVID<ch>:BEIDou:SIGNal:L1Band:B1I:DATA:SCODE[:STATe].....	468
[SOURce<hw>]:BB:GNSS:SVID<ch>:BEIDou:SIGNal:L1Band:B1I:PILot:SCODE[:STATe].....	468
[SOURce<hw>]:BB:GNSS:SVID<ch>:GLONass:SIGNal:L5Band:L3CDma:DATA: SCODE[:STATe].....	468
[SOURce<hw>]:BB:GNSS:SVID<ch>:GLONass:SIGNal:L5Band:L3CDma:PILot: SCODE[:STATe].....	468
[SOURce<hw>]:BB:GNSS:SVID<ch>:GLONass:SIGNal:L2Band:L2CDma:PILot: SCODE[:STATe].....	468
[SOURce<hw>]:BB:GNSS:SVID<ch>:GLONass:SIGNal:L1Band:L1CDma:DATA: SCODE[:STATe].....	468
[SOURce<hw>]:BB:GNSS:SVID<ch>:GALileo:SIGNal:L5Band:E5B:DATA:SCODE[:STATe].....	468
[SOURce<hw>]:BB:GNSS:SVID<ch>:GALileo:SIGNal:L5Band:E5B:PILot:SCODE[:STATe].....	468
[SOURce<hw>]:BB:GNSS:SVID<ch>:GALileo:SIGNal:L5Band:E5A:DATA:SCODE[:STATe].....	468
[SOURce<hw>]:BB:GNSS:SVID<ch>:GALileo:SIGNal:L5Band:E5A:PILot:SCODE[:STATe].....	468
[SOURce<hw>]:BB:GNSS:SVID<ch>:GALileo:SIGNal:L2Band:E6PRs:DATA:SCODE[: STATe].....	468
[SOURce<hw>]:BB:GNSS:SVID<ch>:GALileo:SIGNal:L2Band:E6S:PILot:SCODE[:STATe].....	468
[SOURce<hw>]:BB:GNSS:SVID<ch>:GALileo:SIGNal:L1Band:E1OS:DATA:SCODE[: STATe].....	468
[SOURce<hw>]:BB:GNSS:SVID<ch>:GALileo:SIGNal:L1Band:E1OS:PILot:SCODE[:STATe].....	468
[SOURce<hw>]:BB:GNSS:SVID<ch>:GALileo:SIGNal:L1Band:E1PRs:DATA:SCODE[: STATe].....	468
[SOURce<hw>]:BB:GNSS:SVID<ch>:GPS:SIGNal:L5Band:L5S:DATA:SCODE[:STATe].....	468
[SOURce<hw>]:BB:GNSS:SVID<ch>:GPS:SIGNal:L5Band:L5S:PILot:SCODE[:STATe].....	468
[SOURce<hw>]:BB:GNSS:SVID<ch>:GPS:SIGNal:L2Band:M:DATA:SCODE[:STATe].....	468
[SOURce<hw>]:BB:GNSS:SVID<ch>:GPS:SIGNal:L2Band:PY:DATA:SCODE[:STATe].....	468
[SOURce<hw>]:BB:GNSS:SVID<ch>:GPS:SIGNal:L1Band:M:DATA:SCODE[:STATe].....	468
[SOURce<hw>]:BB:GNSS:SVID<ch>:GPS:SIGNal:L1Band:PY:DATA:SCODE[:STATe].....	468
[SOURce<hw>]:BB:GNSS:SVID<ch>:GPS:SIGNal:L1Band:L1C:PILot:SCODE[:STATe].....	468
[SOURce<hw>]:BB:GNSS:SVID<ch>:SBAS:SIGNal:L5Band:EL5S:DATA:NMESsage: CONTRol.....	469

Signals and power configuration per satellite

[:SOURce<hw>]:BB:GNSS:SVID<ch>:SBAS:SIGNal:L1Band:CA:DATA:NMESSage:CONTrol	469
[:SOURce<hw>]:BB:GNSS:SVID<ch>:NAVic:SIGNal:L5Band:SPS:DATA:NMESSage: CONTrol.....	469
[:SOURce<hw>]:BB:GNSS:SVID<ch>:QZSS:SIGNal:L5Band:L5S:DATA:NMESSage: CONTrol.....	469
[:SOURce<hw>]:BB:GNSS:SVID<ch>:QZSS:SIGNal:L2Band:L2C:DATA:NMESSage: CONTrol.....	469
[:SOURce<hw>]:BB:GNSS:SVID<ch>:QZSS:SIGNal:L1Band:L1C:DATA:NMESSage: CONTrol.....	469
[:SOURce<hw>]:BB:GNSS:SVID<ch>:QZSS:SIGNal:L1Band:CA:DATA:NMESSage: CONTrol.....	469
[:SOURce<hw>]:BB:GNSS:SVID<ch>:BEIDou:SIGNal:L5Band:B2A:DATA:NMESSage: CONTrol.....	469
[:SOURce<hw>]:BB:GNSS:SVID<ch>:BEIDou:SIGNal:L5Band:B2B:DATA:NMESSage: CONTrol.....	469
[:SOURce<hw>]:BB:GNSS:SVID<ch>:BEIDou:SIGNal:L5Band:B2I:DATA:NMESSage: CONTrol.....	469
[:SOURce<hw>]:BB:GNSS:SVID<ch>:BEIDou:SIGNal:L2Band:B3I:DATA:NMESSage: CONTrol.....	469
[:SOURce<hw>]:BB:GNSS:SVID<ch>:BEIDou:SIGNal:L1Band:B1C:DATA:NMESSage: CONTrol.....	469
[:SOURce<hw>]:BB:GNSS:SVID<ch>:BEIDou:SIGNal:L1Band:B1I:DATA:NMESSage: CONTrol.....	469
[:SOURce<hw>]:BB:GNSS:SVID<ch>:GLONass:SIGNal:L5Band:L3CDma:DATA: NMESSage:CONTrol.....	469
[:SOURce<hw>]:BB:GNSS:SVID<ch>:GLONass:SIGNal:L2Band:CA:DATA:NMESSage: CONTrol.....	469
[:SOURce<hw>]:BB:GNSS:SVID<ch>:GLONass:SIGNal:L2Band:L2CDma:DATA: NMESSage:CONTrol.....	469
[:SOURce<hw>]:BB:GNSS:SVID<ch>:GLONass:SIGNal:L1Band:CA:DATA:NMESSage: CONTrol.....	469
[:SOURce<hw>]:BB:GNSS:SVID<ch>:GLONass:SIGNal:L1Band:L1CDma:DATA: NMESSage:CONTrol.....	470
[:SOURce<hw>]:BB:GNSS:SVID<ch>:GALileo:SIGNal:L5Band:E5A:DATA:NMESSage: CONTrol.....	470
[:SOURce<hw>]:BB:GNSS:SVID<ch>:GALileo:SIGNal:L5Band:E5B:DATA:NMESSage: CONTrol.....	470
[:SOURce<hw>]:BB:GNSS:SVID<ch>:GALileo:SIGNal:L2Band:E6PRs:DATA: NMESSage:CONTrol.....	470
[:SOURce<hw>]:BB:GNSS:SVID<ch>:GALileo:SIGNal:L2Band:E6S:DATA:NMESSage: CONTrol.....	470
[:SOURce<hw>]:BB:GNSS:SVID<ch>:GALileo:SIGNal:L1Band:E1OS:DATA: NMESSage:CONTrol.....	470
[:SOURce<hw>]:BB:GNSS:SVID<ch>:GALileo:SIGNal:L1Band:E1PRs:DATA: NMESSage:CONTrol.....	470
[:SOURce<hw>]:BB:GNSS:SVID<ch>:GPS:SIGNal:L5Band:L5S:DATA:NMESSage:CONTrol	470
[:SOURce<hw>]:BB:GNSS:SVID<ch>:GPS:SIGNal:L2Band:CA:DATA:NMESSage:CONTrol	470
[:SOURce<hw>]:BB:GNSS:SVID<ch>:GPS:SIGNal:L2Band:L2C:DATA:NMESSage:CONTrol	470
[:SOURce<hw>]:BB:GNSS:SVID<ch>:GPS:SIGNal:L2Band:M:DATA:NMESSage:CONTrol...	470
[:SOURce<hw>]:BB:GNSS:SVID<ch>:GPS:SIGNal:L2Band:P:DATA:NMESSage:CONTrol....	470

Signals and power configuration per satellite

[SOURce<hw>]:BB:GNSS:SVID<ch>:GPS:SIGNal:L2Band:PY:DATA:NMESSage:CONTRol.. 470

[SOURce<hw>]:BB:GNSS:SVID<ch>:GPS:SIGNal:L1Band:L1C:DATA:NMESSage:CONTRol 470

[SOURce<hw>]:BB:GNSS:SVID<ch>:GPS:SIGNal:L1Band:M:DATA:NMESSage:CONTRol... 470

[SOURce<hw>]:BB:GNSS:SVID<ch>:GPS:SIGNal:L1Band:P:DATA:NMESSage:CONTRol.... 470

[SOURce<hw>]:BB:GNSS:SVID<ch>:GPS:SIGNal:L1Band:PY:DATA:NMESSage:CONTRol.. 470

[SOURce<hw>]:BB:GNSS:SVID<ch>:GPS:SIGNal:L1Band:CA:DATA:NMESSage:CONTRol. 470

[SOURce<hw>]:BB:GNSS:SVID<ch>:SBAS:SIGNal:L5Band:EL5S:DATA:NMESSage:TYPE 471

[SOURce<hw>]:BB:GNSS:SVID<ch>:SBAS:SIGNal:L1Band:CA:DATA:NMESSage:TYPE.... 471

[SOURce<hw>]:BB:GNSS:SVID<ch>:NAVic:SIGNal:L5Band:SPS:DATA:NMESSage:TYPE.. 471

[SOURce<hw>]:BB:GNSS:SVID<ch>:QZSS:SIGNal:L5Band:L5S:DATA:NMESSage:TYPE.. 471

[SOURce<hw>]:BB:GNSS:SVID<ch>:QZSS:SIGNal:L2Band:L2C:DATA:NMESSage:TYPE.. 471

[SOURce<hw>]:BB:GNSS:SVID<ch>:QZSS:SIGNal:L1Band:CA:DATA:NMESSage:TYPE.... 471

[SOURce<hw>]:BB:GNSS:SVID<ch>:QZSS:SIGNal:L1Band:L1C:DATA:NMESSage:TYPE.. 471

[SOURce<hw>]:BB:GNSS:SVID<ch>:BEIDou:SIGNal:L5Band:B2A:DATA:NMESSage:TYPE471

[SOURce<hw>]:BB:GNSS:SVID<ch>:BEIDou:SIGNal:L5Band:B2B:DATA:NMESSage:TYPE471

[SOURce<hw>]:BB:GNSS:SVID<ch>:BEIDou:SIGNal:L5Band:B2I:DATA:NMESSage:TYPE. 471

[SOURce<hw>]:BB:GNSS:SVID<ch>:BEIDou:SIGNal:L2Band:B3I:DATA:NMESSage:TYPE. 471

[SOURce<hw>]:BB:GNSS:SVID<ch>:BEIDou:SIGNal:L1Band:B1C:DATA:NMESSage:TYPE471

[SOURce<hw>]:BB:GNSS:SVID<ch>:BEIDou:SIGNal:L1Band:B1I:DATA:NMESSage:TYPE. 471

[SOURce<hw>]:BB:GNSS:SVID<ch>:GLONass:SIGNal:L5Band:L3CDma:DATA:
NMESSage:TYPE..... 471

[SOURce<hw>]:BB:GNSS:SVID<ch>:GLONass:SIGNal:L2Band:CA:DATA:NMESSage:
TYPE.....471

[SOURce<hw>]:BB:GNSS:SVID<ch>:GLONass:SIGNal:L2Band:L2CDma:DATA:
NMESSage:TYPE..... 471

[SOURce<hw>]:BB:GNSS:SVID<ch>:GLONass:SIGNal:L1Band:CA:DATA:NMESSage:
TYPE.....471

[SOURce<hw>]:BB:GNSS:SVID<ch>:GLONass:SIGNal:L1Band:L1CDma:DATA:
NMESSage:TYPE..... 471

[SOURce<hw>]:BB:GNSS:SVID<ch>:GALileo:SIGNal:L5Band:E5A:DATA:NMESSage:
TYPE.....471

[SOURce<hw>]:BB:GNSS:SVID<ch>:GALileo:SIGNal:L5Band:E5B:DATA:NMESSage:
TYPE.....471

[SOURce<hw>]:BB:GNSS:SVID<ch>:GALileo:SIGNal:L2Band:E6PRs:DATA:
NMESSage:TYPE..... 471

[SOURce<hw>]:BB:GNSS:SVID<ch>:GALileo:SIGNal:L2Band:E6S:DATA:NMESSage:
TYPE.....471

[SOURce<hw>]:BB:GNSS:SVID<ch>:GALileo:SIGNal:L1Band:E1OS:DATA:
NMESSage:TYPE..... 472

[SOURce<hw>]:BB:GNSS:SVID<ch>:GALileo:SIGNal:L1Band:E1PRs:DATA:
NMESSage:TYPE..... 472

[SOURce<hw>]:BB:GNSS:SVID<ch>:GPS:SIGNal:L5Band:L5S:DATA:NMESSage:TYPE.... 472

[SOURce<hw>]:BB:GNSS:SVID<ch>:GPS:SIGNal:L2Band:CA:DATA:NMESSage:TYPE.....472

[SOURce<hw>]:BB:GNSS:SVID<ch>:GPS:SIGNal:L2Band:L2C:DATA:NMESSage:TYPE.... 472

[SOURce<hw>]:BB:GNSS:SVID<ch>:GPS:SIGNal:L2Band:M:DATA:NMESSage:TYPE..... 472

[SOURce<hw>]:BB:GNSS:SVID<ch>:GPS:SIGNal:L2Band:P:DATA:NMESSage:TYPE..... 472

[SOURce<hw>]:BB:GNSS:SVID<ch>:GPS:SIGNal:L2Band:PY:DATA:NMESSage:TYPE..... 472

[SOURce<hw>]:BB:GNSS:SVID<ch>:GPS:SIGNal:L1Band:L1C:DATA:NMESSage:TYPE.... 472

[SOURce<hw>]:BB:GNSS:SVID<ch>:GPS:SIGNal:L1Band:M:DATA:NMESSage:TYPE..... 472

[SOURce<hw>]:BB:GNSS:SVID<ch>:GPS:SIGNal:L1Band:P:DATA:NMESSage:TYPE..... 472

Signals and power configuration per satellite

[SOURce<hw>]:BB:GNSS:SVID<ch>:GPS:SIGNal:L1Band:PY:DATA:NMESSage:TYPE.....	472
[SOURce<hw>]:BB:GNSS:SVID<ch>:GPS:SIGNal:L1Band:CA:DATA:NMESSage:TYPE.....	472
[SOURce<hw>]:BB:GNSS:SVID<ch>:SBAS:SIGNal:L5Band:EL5S:DATA:NMESSage: DSElect.....	473
[SOURce<hw>]:BB:GNSS:SVID<ch>:SBAS:SIGNal:L1Band:CA:DATA:NMESSage:DSElect	473
[SOURce<hw>]:BB:GNSS:SVID<ch>:NAVic:SIGNal:L5Band:SPS:DATA:NMESSage: DSElect.....	473
[SOURce<hw>]:BB:GNSS:SVID<ch>:QZSS:SIGNal:L5Band:L5S:DATA:NMESSage: DSElect.....	473
[SOURce<hw>]:BB:GNSS:SVID<ch>:QZSS:SIGNal:L2Band:L2C:DATA:NMESSage: DSElect.....	473
[SOURce<hw>]:BB:GNSS:SVID<ch>:QZSS:SIGNal:L1Band:CA:DATA:NMESSage: DSElect.....	473
[SOURce<hw>]:BB:GNSS:SVID<ch>:QZSS:SIGNal:L1Band:L1C:DATA:NMESSage: DSElect.....	473
[SOURce<hw>]:BB:GNSS:SVID<ch>:BEIDou:SIGNal:L5Band:B2A:DATA:NMESSage: DSElect.....	473
[SOURce<hw>]:BB:GNSS:SVID<ch>:BEIDou:SIGNal:L5Band:B2B:DATA:NMESSage: DSElect.....	473
[SOURce<hw>]:BB:GNSS:SVID<ch>:BEIDou:SIGNal:L5Band:B2I:DATA:NMESSage: DSElect.....	473
[SOURce<hw>]:BB:GNSS:SVID<ch>:BEIDou:SIGNal:L2Band:B3I:DATA:NMESSage: DSElect.....	473
[SOURce<hw>]:BB:GNSS:SVID<ch>:BEIDou:SIGNal:L1Band:B1C:DATA:NMESSage: DSElect.....	473
[SOURce<hw>]:BB:GNSS:SVID<ch>:BEIDou:SIGNal:L1Band:B1I:DATA:NMESSage: DSElect.....	473
[SOURce<hw>]:BB:GNSS:SVID<ch>:GLONass:SIGNal:L5Band:L3CDma:DATA: NMESSage:DSElect.....	473
[SOURce<hw>]:BB:GNSS:SVID<ch>:GLONass:SIGNal:L2Band:CA:DATA:NMESSage: DSElect.....	473
[SOURce<hw>]:BB:GNSS:SVID<ch>:GLONass:SIGNal:L2Band:L2CDma:DATA: NMESSage:DSElect.....	473
[SOURce<hw>]:BB:GNSS:SVID<ch>:GLONass:SIGNal:L1Band:CA:DATA:NMESSage: DSElect.....	473
[SOURce<hw>]:BB:GNSS:SVID<ch>:GLONass:SIGNal:L1Band:L1CDma:DATA: NMESSage:DSElect.....	473
[SOURce<hw>]:BB:GNSS:SVID<ch>:GALileo:SIGNal:L5Band:E5A:DATA:NMESSage: DSElect.....	473
[SOURce<hw>]:BB:GNSS:SVID<ch>:GALileo:SIGNal:L5Band:E5B:DATA:NMESSage: DSElect.....	473
[SOURce<hw>]:BB:GNSS:SVID<ch>:GALileo:SIGNal:L2Band:E6PRs:DATA: NMESSage:DSElect.....	473
[SOURce<hw>]:BB:GNSS:SVID<ch>:GALileo:SIGNal:L2Band:E6S:DATA:NMESSage: DSElect.....	473
[SOURce<hw>]:BB:GNSS:SVID<ch>:GALileo:SIGNal:L1Band:E1OS:DATA: NMESSage:DSElect.....	474
[SOURce<hw>]:BB:GNSS:SVID<ch>:GALileo:SIGNal:L1Band:E1PRs:DATA: NMESSage:DSElect.....	474
[SOURce<hw>]:BB:GNSS:SVID<ch>:GPS:SIGNal:L5Band:L5S:DATA:NMESSage:DSElect	474

Signals and power configuration per satellite

[SOURce<hw>]:BB:GNSS:SVID<ch>:GPS:SIGNal:L2Band:CA:DATA:NMESSage:DSElect. 474

[SOURce<hw>]:BB:GNSS:SVID<ch>:GPS:SIGNal:L2Band:L2C:DATA:NMESSage:DSElect. 474

[SOURce<hw>]:BB:GNSS:SVID<ch>:GPS:SIGNal:L2Band:M:DATA:NMESSage:DSElect... 474

[SOURce<hw>]:BB:GNSS:SVID<ch>:GPS:SIGNal:L2Band:P:DATA:NMESSage:DSElect... 474

[SOURce<hw>]:BB:GNSS:SVID<ch>:GPS:SIGNal:L2Band:PY:DATA:NMESSage:DSElect... 474

[SOURce<hw>]:BB:GNSS:SVID<ch>:GPS:SIGNal:L1Band:L1C:DATA:NMESSage:DSElect. 474

[SOURce<hw>]:BB:GNSS:SVID<ch>:GPS:SIGNal:L1Band:M:DATA:NMESSage:DSElect... 474

[SOURce<hw>]:BB:GNSS:SVID<ch>:GPS:SIGNal:L1Band:P:DATA:NMESSage:DSElect... 474

[SOURce<hw>]:BB:GNSS:SVID<ch>:GPS:SIGNal:L1Band:PY:DATA:NMESSage:DSElect... 474

[SOURce<hw>]:BB:GNSS:SVID<ch>:GPS:SIGNal:L1Band:CA:DATA:NMESSage:DSElect. 474

[SOURce<hw>]:BB:GNSS:SVID<ch>:GALileo:SIGNal:L1Band:E1OS:DATA:OSNMa[
 STATE]. 474

[SOURce<hw>]:BB:GNSS:SVID<ch>:SBAS:SIGNal:L5Band:EL5S:DATA:NMESSage:
 PATtern. 475

[SOURce<hw>]:BB:GNSS:SVID<ch>:SBAS:SIGNal:L1Band:CA:DATA:NMESSage:PATtern 475

[SOURce<hw>]:BB:GNSS:SVID<ch>:NAVic:SIGNal:L5Band:SPS:DATA:NMESSage:
 PATtern. 475

[SOURce<hw>]:BB:GNSS:SVID<ch>:QZSS:SIGNal:L5Band:L5S:DATA:NMESSage:
 PATtern. 475

[SOURce<hw>]:BB:GNSS:SVID<ch>:QZSS:SIGNal:L2Band:L2C:DATA:NMESSage:
 PATtern. 475

[SOURce<hw>]:BB:GNSS:SVID<ch>:QZSS:SIGNal:L1Band:CA:DATA:NMESSage:PATtern 475

[SOURce<hw>]:BB:GNSS:SVID<ch>:QZSS:SIGNal:L1Band:L1C:DATA:NMESSage:
 PATtern. 475

[SOURce<hw>]:BB:GNSS:SVID<ch>:BEIDou:SIGNal:L5Band:B2A:DATA:NMESSage:
 PATtern. 475

[SOURce<hw>]:BB:GNSS:SVID<ch>:BEIDou:SIGNal:L5Band:B2B:DATA:NMESSage:
 PATtern. 475

[SOURce<hw>]:BB:GNSS:SVID<ch>:BEIDou:SIGNal:L5Band:B2I:DATA:NMESSage:
 PATtern. 475

[SOURce<hw>]:BB:GNSS:SVID<ch>:BEIDou:SIGNal:L2Band:B3I:DATA:NMESSage:
 PATtern. 475

[SOURce<hw>]:BB:GNSS:SVID<ch>:BEIDou:SIGNal:L1Band:B1C:DATA:NMESSage:
 PATtern. 475

[SOURce<hw>]:BB:GNSS:SVID<ch>:BEIDou:SIGNal:L1Band:B1I:DATA:NMESSage:
 PATtern. 475

[SOURce<hw>]:BB:GNSS:SVID<ch>:GLONass:SIGNal:L5Band:L3CDma:DATA:
 NMESSage:PATtern. 475

[SOURce<hw>]:BB:GNSS:SVID<ch>:GLONass:SIGNal:L2Band:CA:DATA:NMESSage:
 PATtern. 475

[SOURce<hw>]:BB:GNSS:SVID<ch>:GLONass:SIGNal:L2Band:L2CDma:DATA:
 NMESSage:PATtern. 475

[SOURce<hw>]:BB:GNSS:SVID<ch>:GLONass:SIGNal:L1Band:CA:DATA:NMESSage:
 PATtern. 475

[SOURce<hw>]:BB:GNSS:SVID<ch>:GLONass:SIGNal:L1Band:L1CDma:DATA:
 NMESSage:PATtern. 475

[SOURce<hw>]:BB:GNSS:SVID<ch>:GALileo:SIGNal:L5Band:E5A:DATA:NMESSage:
 PATtern. 475

[SOURce<hw>]:BB:GNSS:SVID<ch>:GALileo:SIGNal:L5Band:E5B:DATA:NMESSage:
 PATtern. 475

Signals and power configuration per satellite

[:SOURce<hw>]:BB:GNSS:SVID<ch>:GALileo:SIGNal:L2Band:E6PRs:DATA: NMESSage:PATtern.....	475
[:SOURce<hw>]:BB:GNSS:SVID<ch>:GALileo:SIGNal:L2Band:E6S:DATA:NMESSage: PATtern.....	475
[:SOURce<hw>]:BB:GNSS:SVID<ch>:GALileo:SIGNal:L1Band:E1OS:DATA: NMESSage:PATtern.....	475
[:SOURce<hw>]:BB:GNSS:SVID<ch>:GALileo:SIGNal:L1Band:E1PRs:DATA: NMESSage:PATtern.....	475
[:SOURce<hw>]:BB:GNSS:SVID<ch>:GPS:SIGNal:L5Band:L5S:DATA:NMESSage:PATtern..	476
[:SOURce<hw>]:BB:GNSS:SVID<ch>:GPS:SIGNal:L2Band:CA:DATA:NMESSage:PATtern..	476
[:SOURce<hw>]:BB:GNSS:SVID<ch>:GPS:SIGNal:L2Band:L2C:DATA:NMESSage:PATtern..	476
[:SOURce<hw>]:BB:GNSS:SVID<ch>:GPS:SIGNal:L2Band:M:DATA:NMESSage:PATtern....	476
[:SOURce<hw>]:BB:GNSS:SVID<ch>:GPS:SIGNal:L2Band:P:DATA:NMESSage:PATtern....	476
[:SOURce<hw>]:BB:GNSS:SVID<ch>:GPS:SIGNal:L2Band:PY:DATA:NMESSage:PATtern..	476
[:SOURce<hw>]:BB:GNSS:SVID<ch>:GPS:SIGNal:L1Band:L1C:DATA:NMESSage:PATtern..	476
[:SOURce<hw>]:BB:GNSS:SVID<ch>:GPS:SIGNal:L1Band:M:DATA:NMESSage:PATtern....	476
[:SOURce<hw>]:BB:GNSS:SVID<ch>:GPS:SIGNal:L1Band:P:DATA:NMESSage:PATtern....	476
[:SOURce<hw>]:BB:GNSS:SVID<ch>:GPS:SIGNal:L1Band:PY:DATA:NMESSage:PATtern..	476
[:SOURce<hw>]:BB:GNSS:SVID<ch>:GPS:SIGNal:L1Band:CA:DATA:NMESSage:PATtern..	476
[:SOURce<hw>]:BB:GNSS:SVID<ch>:GLONass:SIGNal:L2Band:CA:DATA: MEANdering[:STATe].....	476
[:SOURce<hw>]:BB:GNSS:SVID<ch>:GLONass:SIGNal:L1Band:CA:DATA: MEANdering[:STATe].....	476
[:SOURce<hw>]:BB:GNSS:SVID<ch>:GLONass:SIGNal:L2Band:CA:DATA: TSEQUence[:STATe].....	477
[:SOURce<hw>]:BB:GNSS:SVID<ch>:GLONass:SIGNal:L1Band:CA:DATA: TSEQUence[:STATe].....	477
[:SOURce<hw>]:BB:GNSS:SVID<ch>:SBAS:MCONtrol:COPY:SVID.....	477
[:SOURce<hw>]:BB:GNSS:SVID<ch>:NAVic:MCONtrol:COPY:SVID.....	477
[:SOURce<hw>]:BB:GNSS:SVID<ch>:QZSS:MCONtrol:COPY:SVID.....	477
[:SOURce<hw>]:BB:GNSS:SVID<ch>:BEIDou:MCONtrol:COPY:SVID.....	477
[:SOURce<hw>]:BB:GNSS:SVID<ch>:GLONass:MCONtrol:COPY:SVID.....	477
[:SOURce<hw>]:BB:GNSS:SVID<ch>:GALileo:MCONtrol:COPY:SVID.....	477
[:SOURce<hw>]:BB:GNSS:SVID<ch>:GPS:MCONtrol:COPY:SVID.....	477
[:SOURce<hw>]:BB:GNSS:SVID<ch>:SBAS:MCONtrol:COPY:EXECute.....	478
[:SOURce<hw>]:BB:GNSS:SVID<ch>:NAVic:MCONtrol:COPY:EXECute.....	478
[:SOURce<hw>]:BB:GNSS:SVID<ch>:QZSS:MCONtrol:COPY:EXECute.....	478
[:SOURce<hw>]:BB:GNSS:SVID<ch>:BEIDou:MCONtrol:COPY:EXECute.....	478
[:SOURce<hw>]:BB:GNSS:SVID<ch>:GLONass:MCONtrol:COPY:EXECute.....	478
[:SOURce<hw>]:BB:GNSS:SVID<ch>:GALileo:MCONtrol:COPY:EXECute.....	478
[:SOURce<hw>]:BB:GNSS:SVID<ch>:GPS:MCONtrol:COPY:EXECute.....	478
<hr/>	
[:SOURce<hw>]:BB:GNSS:SVID<ch>:SBAS:STATe <SvState>	
[:SOURce<hw>]:BB:GNSS:SVID<ch>:NAVic:STATe <SvState>	
[:SOURce<hw>]:BB:GNSS:SVID<ch>:QZSS:STATe <SvState>	
[:SOURce<hw>]:BB:GNSS:SVID<ch>:BEIDou:STATe <SvState>	
[:SOURce<hw>]:BB:GNSS:SVID<ch>:GLONass:STATe <SvState>	

[:SOURce<hw>]:BB:GNSS:SVID<ch>:GALileo:STATe <SvState>
[:SOURce<hw>]:BB:GNSS:SVID<ch>:GPS:STATe <SvState>

Activates the SV ID.

Parameters:

<SvState> 1 | ON | 0 | OFF
 *RST: 0

Example: See [Example "To configure SV power and modulation control"](#) on page 448.

Manual operation: See ["State \(SV ID\)"](#) on page 76

[:SOURce<hw>]:BB:GNSS:SVID<ch>:SBAS:PRESent <PresentInConst>
[:SOURce<hw>]:BB:GNSS:SVID<ch>:NAVIC:PRESent <PresentInConst>
[:SOURce<hw>]:BB:GNSS:SVID<ch>:QZSS:PRESent <PresentInConst>
[:SOURce<hw>]:BB:GNSS:SVID<ch>:BEIDou:PRESent <PresentInConst>
[:SOURce<hw>]:BB:GNSS:SVID<ch>:GLONass:PRESent <PresentInConst>
[:SOURce<hw>]:BB:GNSS:SVID<ch>:GALileo:PRESent <PresentInConst>
[:SOURce<hw>]:BB:GNSS:SVID<ch>:GPS:PRESent <PresentInConst>

Includes the SV ID in the currents constellation.

Parameters:

<PresentInConst> 1 | ON | 0 | OFF
 *RST: 1

Example: See [Example "To configure SV power and modulation control"](#) on page 448.

Manual operation: See ["Present in Constellation"](#) on page 86

[:SOURce<hw>]:BB:GNSS:SVID<ch>:GLONass:FNUMber <FreqNum>

Queries the frequency number of the subcarrier.

Parameters:

<FreqNum> integer
 Range: -7 to 13
 *RST: 0

Example: SOURce1:BB:GNSS:SVID15:GLONass:FNUMber?

Manual operation: See ["Frequency Number"](#) on page 87

[:SOURce<hw>]:BB:GNSS:POWer:REFErence <ReferencePower>

Sets the power level that is used as a reference for the calculation of the power level of the satellites.

Signals and power configuration per satellite

Parameters:

<ReferencePower> float
 Range: -145 to 20
 Increment: 0.01
 *RST: -30

Example: See [Example "To configure SV power and modulation control"](#) on page 448.

Manual operation: See ["Reference Power"](#) on page 75
 See ["Reference Power \(Carrier\)"](#) on page 197

```
[ :SOURce<hw>]:BB:GNSS:SVID<ch>:SBAS:POWer:PLOSS <PathLossState>
[:SOURce<hw>]:BB:GNSS:SVID<ch>:NAVic:POWer:PLOSS <PathLossState>
[:SOURce<hw>]:BB:GNSS:SVID<ch>:QZSS:POWer:PLOSS <PathLossState>
[:SOURce<hw>]:BB:GNSS:SVID<ch>:BEIDou:POWer:PLOSS <PathLossState>
[:SOURce<hw>]:BB:GNSS:SVID<ch>:GLONass:POWer:PLOSS <PathLossState>
[:SOURce<hw>]:BB:GNSS:SVID<ch>:GALileo:POWer:PLOSS <PathLossState>
[:SOURce<hw>]:BB:GNSS:SVID<ch>:GPS:POWer:PLOSS <PathLossState>
```

If enabled, the power of the SV ID signals is reduced to account for the free space attenuation.

Parameters:

<PathLossState> 1 | ON | 0 | OFF
 *RST: 0

Example: See [Example "To configure SV power and modulation control"](#) on page 448.

Manual operation: See ["Add Power Path-Loss"](#) on page 87

```
[ :SOURce<hw>]:BB:GNSS:SVID<ch>:SBAS:POWer:OFFSet <PowerOffset>
[:SOURce<hw>]:BB:GNSS:SVID<ch>:NAVic:POWer:OFFSet <PowerOffset>
[:SOURce<hw>]:BB:GNSS:SVID<ch>:QZSS:POWer:OFFSet <PowerOffset>
[:SOURce<hw>]:BB:GNSS:SVID<ch>:BEIDou:POWer:OFFSet <PowerOffset>
[:SOURce<hw>]:BB:GNSS:SVID<ch>:GLONass:POWer:OFFSet <PowerOffset>
[:SOURce<hw>]:BB:GNSS:SVID<ch>:GALileo:POWer:OFFSet <PowerOffset>
[:SOURce<hw>]:BB:GNSS:SVID<ch>:GPS:POWer:OFFSet <PowerOffset>
```

Reduces the signal of the selected SV ID by the defined value.

Parameters:

<PowerOffset> float
 Range: -21 to 0
 Increment: 0.01
 *RST: 0

Example: See [Example "To configure SV power and modulation control"](#) on page 448.

Manual operation: See ["Power Offset"](#) on page 77

```

[:SOURce<hw>]:BB:GNSS:SVID<ch>:SBAS:SIGNal:L5Band:EL5S:POWer:OFFset
<PowerOffset>
[:SOURce<hw>]:BB:GNSS:SVID<ch>:SBAS:SIGNal:L1Band:CA:POWer:OFFset
<PowerOffset>
[:SOURce<hw>]:BB:GNSS:SVID<ch>:NAVic:SIGNal:L5Band:SPS:POWer:OFFset
<PowerOffset>
[:SOURce<hw>]:BB:GNSS:SVID<ch>:QZSS:SIGNal:L5Band:L5S:POWer:OFFset
<PowerOffset>
[:SOURce<hw>]:BB:GNSS:SVID<ch>:QZSS:SIGNal:L2Band:L2C:POWer:OFFset
<PowerOffset>
[:SOURce<hw>]:BB:GNSS:SVID<ch>:QZSS:SIGNal:L1Band:L1C:POWer:OFFset
<PowerOffset>
[:SOURce<hw>]:BB:GNSS:SVID<ch>:QZSS:SIGNal:L1Band:CA:POWer:OFFset
<PowerOffset>
[:SOURce<hw>]:BB:GNSS:SVID<ch>:BEIDou:SIGNal:L5Band:B2I:POWer:OFFset
<PowerOffset>
[:SOURce<hw>]:BB:GNSS:SVID<ch>:BEIDou:SIGNal:L5Band:B2B:POWer:
OFFset <PowerOffset>
[:SOURce<hw>]:BB:GNSS:SVID<ch>:BEIDou:SIGNal:L5Band:B2A:POWer:
OFFset <PowerOffset>
[:SOURce<hw>]:BB:GNSS:SVID<ch>:BEIDou:SIGNal:L2Band:B3I:POWer:OFFset
<PowerOffset>
[:SOURce<hw>]:BB:GNSS:SVID<ch>:BEIDou:SIGNal:L1Band:B1I:POWer:OFFset
<PowerOffset>
[:SOURce<hw>]:BB:GNSS:SVID<ch>:BEIDou:SIGNal:L1Band:B1C:POWer:
OFFset <PowerOffset>
[:SOURce<hw>]:BB:GNSS:SVID<ch>:GLONass:SIGNal:L5Band:L3CDma:POWer:
OFFset <PowerOffset>
[:SOURce<hw>]:BB:GNSS:SVID<ch>:GLONass:SIGNal:L2Band:L2CDma:POWer:
OFFset <PowerOffset>
[:SOURce<hw>]:BB:GNSS:SVID<ch>:GLONass:SIGNal:L2Band:CA:POWer:
OFFset <PowerOffset>
[:SOURce<hw>]:BB:GNSS:SVID<ch>:GLONass:SIGNal:L1Band:L1CDma:POWer:
OFFset <PowerOffset>
[:SOURce<hw>]:BB:GNSS:SVID<ch>:GLONass:SIGNal:L1Band:CA:POWer:
OFFset <PowerOffset>
[:SOURce<hw>]:BB:GNSS:SVID<ch>:GALileo:SIGNal:L5Band:E5B:POWer:
OFFset <PowerOffset>
[:SOURce<hw>]:BB:GNSS:SVID<ch>:GALileo:SIGNal:L5Band:E5A:POWer:
OFFset <PowerOffset>
[:SOURce<hw>]:BB:GNSS:SVID<ch>:GALileo:SIGNal:L2Band:E6PRs:POWer:
OFFset <PowerOffset>
[:SOURce<hw>]:BB:GNSS:SVID<ch>:GALileo:SIGNal:L2Band:E6S:POWer:
OFFset <PowerOffset>
[:SOURce<hw>]:BB:GNSS:SVID<ch>:GALileo:SIGNal:L1Band:E1OS:POWer:
OFFset <PowerOffset>
[:SOURce<hw>]:BB:GNSS:SVID<ch>:GALileo:SIGNal:L1Band:E1PRs:POWer:
OFFset <PowerOffset>

```

```

[:SOURce<hw>]:BB:GNSS:SVID<ch>:GPS:SIGNal:L5Band:L5S:POWer:OFFset
  <PowerOffset>
[:SOURce<hw>]:BB:GNSS:SVID<ch>:GPS:SIGNal:L2Band:L2C:POWer:OFFset
  <PowerOffset>
[:SOURce<hw>]:BB:GNSS:SVID<ch>:GPS:SIGNal:L2Band:M:POWer:OFFset
  <PowerOffset>
[:SOURce<hw>]:BB:GNSS:SVID<ch>:GPS:SIGNal:L2Band:P:POWer:OFFset
  <PowerOffset>
[:SOURce<hw>]:BB:GNSS:SVID<ch>:GPS:SIGNal:L2Band:PY:POWer:OFFset
  <PowerOffset>
[:SOURce<hw>]:BB:GNSS:SVID<ch>:GPS:SIGNal:L2Band:CA:POWer:OFFset
  <PowerOffset>
[:SOURce<hw>]:BB:GNSS:SVID<ch>:GPS:SIGNal:L1Band:L1C:POWer:OFFset
  <PowerOffset>
[:SOURce<hw>]:BB:GNSS:SVID<ch>:GPS:SIGNal:L1Band:M:POWer:OFFset
  <PowerOffset>
[:SOURce<hw>]:BB:GNSS:SVID<ch>:GPS:SIGNal:L1Band:P:POWer:OFFset
  <PowerOffset>
[:SOURce<hw>]:BB:GNSS:SVID<ch>:GPS:SIGNal:L1Band:PY:POWer:OFFset
  <PowerOffset>
[:SOURce<hw>]:BB:GNSS:SVID<ch>:GPS:SIGNal:L1Band:CA:POWer:OFFset
  <PowerOffset>

```

Sets a power offset for the selected signal.

Parameters:

<PowerOffset>	float
	Range: -6 to 0
	Increment: 0.01
	*RST: 0

Example: See [Example "To configure SV power and modulation control"](#) on page 448.

Manual operation: See ["Signal Power Offset"](#) on page 87

```

[:SOURce<hw>]:BB:GNSS:SVID<ch>:SBAS:POWer:COPIY:SVID <Svid>
[:SOURce<hw>]:BB:GNSS:SVID<ch>:NAVic:POWer:COPIY:SVID <Svid>
[:SOURce<hw>]:BB:GNSS:SVID<ch>:QZSS:POWer:COPIY:SVID <Svid>
[:SOURce<hw>]:BB:GNSS:SVID<ch>:BEIDou:POWer:COPIY:SVID <Svid>
[:SOURce<hw>]:BB:GNSS:SVID<ch>:GLONass:POWer:COPIY:SVID <Svid>
[:SOURce<hw>]:BB:GNSS:SVID<ch>:GALileo:POWer:COPIY:SVID <Svid>
[:SOURce<hw>]:BB:GNSS:SVID<ch>:GPS:POWer:COPIY:SVID <Svid>

```

Sets the SV ID to that the configuration form the current satellite (SVID<ch>) is applied.

Both SV IDs belong to the same GNSS system.

Parameters:

<Svid> 1 | 2 | 3 | 5 | 4 | 6 | 7 | 8 | 9 | 10 | 11 | 12 | 13 | 14 | 15 | 16 | 17 |
 19 | 18 | 20 | 21 | 22 | 23 | 24 | 25 | 26 | 27 | 28 | 29 | 30 | 31 |
 32 | 33 | 34 | 35 | 36 | 37 | 38 | 39 | 40 | 41 | 42 | 43 | 44 | 45 |
 46 | 47 | 48 | 49 | 50 | 51 | 52 | 53 | 54 | 55 | 56 | 57 | 58 | 59 |
 60 | 61 | 62 | 63 | 64 | 65 | 66 | 67 | 68 | 69 | 70 | 71 | 72 | 73 |
 74 | 75 | 76 | 77 | 78 | 79 | 80 | 81 | 82 | 83 | 84 | 85 | 86 | 87 |
 88 | 89 | 90 | 91 | 92 | 93 | 94 | 95 | 96 | 97 | 98 | 99 | 100 | 101 |
 102 | 103 | 104 | 105 | 106 | 107 | 108 | 109 | 110 | 111 | 112 |
 113 | 114 | 115 | 116 | 117 | 118 | 119 | 120 | 121 | 122 | 123 |
 124 | 125 | 126 | 127 | 128 | 129 | 130 | 131 | 132 | 133 | 134 |
 135 | 136 | 137 | 138 | 139 | 140 | 141 | 142 | 143 | 144 | 145 |
 146 | 147 | 148 | 149 | 150 | 151 | 152 | 153 | 154 | 155 | 156 |
 157 | 158 | 159 | 160 | 161 | 162 | 163 | 164 | 165 | 166 | 167 |
 168 | 169 | 170 | 171 | 172 | 173 | 174 | 175 | 176 | 177 | 178 |
 179 | 180 | 181 | 182 | 183 | 184 | 185 | 186 | 187 | 188 | 189 |
 190 | 191 | 192 | 193 | 194 | 195 | 196 | 197 | 198 | 199 | 200 |
 ALL
 *RST: 1

Example: See [Example "To configure SV power and modulation control"](#) on page 448.

Manual operation: See ["Copy Power Settings to,SV-ID"](#) on page 87

```
[ :SOURce<hw>]:BB:GNSS:SVID<ch>:SBAS:POWer:COPIY:EXECute
[ :SOURce<hw>]:BB:GNSS:SVID<ch>:NAVic:POWer:COPIY:EXECute
[ :SOURce<hw>]:BB:GNSS:SVID<ch>:QZSS:POWer:COPIY:EXECute
[ :SOURce<hw>]:BB:GNSS:SVID<ch>:BEIDou:POWer:COPIY:EXECute
[ :SOURce<hw>]:BB:GNSS:SVID<ch>:GLONass:POWer:COPIY:EXECute
[ :SOURce<hw>]:BB:GNSS:SVID<ch>:GALileo:POWer:COPIY:EXECute
[ :SOURce<hw>]:BB:GNSS:SVID<ch>:GPS:POWer:COPIY:EXECute
```

Applies the configuration of the current satellite (SVID<ch>:<GNSS system>) to the satellite defined with the command [\[:SOURce<hw>\]:BB:GNSS:SVID<ch>:GPS:POWer:COPIY:SVID](#).

Both SV IDs belong to the same GNSS system.

Example: See [Example "To configure SV power and modulation control"](#) on page 448.

Usage: Event

Manual operation: See ["Copy Power Settings to,SV-ID"](#) on page 87

```
[ :SOURce<hw>]:BB:GNSS:SVID<ch>:SBAS:SIGNal:L5Band:EL5S[:STATe]
<State>
[ :SOURce<hw>]:BB:GNSS:SVID<ch>:SBAS:SIGNal:L1Band:CA[:STATe] <State>
[ :SOURce<hw>]:BB:GNSS:SVID<ch>:NAVic:SIGNal:L5Band:SPS[:STATe] <State>
[ :SOURce<hw>]:BB:GNSS:SVID<ch>:QZSS:SIGNal:L5Band:L5S[:STATe] <State>
```

Signals and power configuration per satellite

```

[:SOURce<hw>]:BB:GNSS:SVID<ch>:QZSS:SIGNal:L2Band:L2C[:STATe] <State>
[:SOURce<hw>]:BB:GNSS:SVID<ch>:QZSS:SIGNal:L1Band:L1C[:STATe] <State>
[:SOURce<hw>]:BB:GNSS:SVID<ch>:QZSS:SIGNal:L1Band:CA[:STATe] <State>
[:SOURce<hw>]:BB:GNSS:SVID<ch>:BEIDou:SIGNal:L5Band:B2I[:STATe]
<State>
[:SOURce<hw>]:BB:GNSS:SVID<ch>:BEIDou:SIGNal:L5Band:B2A[:STATe]
<State>
[:SOURce<hw>]:BB:GNSS:SVID<ch>:BEIDou:SIGNal:L5Band:B2B[:STATe]
<State>
[:SOURce<hw>]:BB:GNSS:SVID<ch>:BEIDou:SIGNal:L2Band:B3I[:STATe]
<State>
[:SOURce<hw>]:BB:GNSS:SVID<ch>:BEIDou:SIGNal:L1Band:B1I[:STATe]
<State>
[:SOURce<hw>]:BB:GNSS:SVID<ch>:BEIDou:SIGNal:L1Band:B1C[:STATe]
<State>
[:SOURce<hw>]:BB:GNSS:SVID<ch>:GLONass:SIGNal:L5Band:L3CDma[:STATe]
<State>
[:SOURce<hw>]:BB:GNSS:SVID<ch>:GLONass:SIGNal:L2Band:L2CDma[:STATe]
<State>
[:SOURce<hw>]:BB:GNSS:SVID<ch>:GLONass:SIGNal:L2Band:CA[:STATe]
<State>
[:SOURce<hw>]:BB:GNSS:SVID<ch>:GLONass:SIGNal:L1Band:L1CDma[:STATe]
<State>
[:SOURce<hw>]:BB:GNSS:SVID<ch>:GALileo:SIGNal:L5Band:E5B[:STATe]
<State>
[:SOURce<hw>]:BB:GNSS:SVID<ch>:GALileo:SIGNal:L5Band:E5A[:STATe]
<State>
[:SOURce<hw>]:BB:GNSS:SVID<ch>:GALileo:SIGNal:L2Band:E6PRs[:STATe]
<State>
[:SOURce<hw>]:BB:GNSS:SVID<ch>:GALileo:SIGNal:L2Band:E6S[:STATe]
<State>
[:SOURce<hw>]:BB:GNSS:SVID<ch>:GALileo:SIGNal:L1Band:E1OS[:STATe]
<State>
[:SOURce<hw>]:BB:GNSS:SVID<ch>:GALileo:SIGNal:L1Band:E1PRs[:STATe]
<State>
[:SOURce<hw>]:BB:GNSS:SVID<ch>:GPS:SIGNal:L5Band:L5S[:STATe] <State>
[:SOURce<hw>]:BB:GNSS:SVID<ch>:GPS:SIGNal:L2Band:CA[:STATe] <State>
[:SOURce<hw>]:BB:GNSS:SVID<ch>:GPS:SIGNal:L2Band:L2C[:STATe] <State>
[:SOURce<hw>]:BB:GNSS:SVID<ch>:GPS:SIGNal:L2Band:M[:STATe] <State>
[:SOURce<hw>]:BB:GNSS:SVID<ch>:GPS:SIGNal:L2Band:P[:STATe] <State>
[:SOURce<hw>]:BB:GNSS:SVID<ch>:GPS:SIGNal:L2Band:PY[:STATe] <State>
[:SOURce<hw>]:BB:GNSS:SVID<ch>:GPS:SIGNal:L1Band:L1C[:STATe] <State>
[:SOURce<hw>]:BB:GNSS:SVID<ch>:GPS:SIGNal:L1Band:M[:STATe] <State>
[:SOURce<hw>]:BB:GNSS:SVID<ch>:GPS:SIGNal:L1Band:P[:STATe] <State>
[:SOURce<hw>]:BB:GNSS:SVID<ch>:GPS:SIGNal:L1Band:PY[:STATe] <State>
[:SOURce<hw>]:BB:GNSS:SVID<ch>:GPS:SIGNal:L1Band:CA[:STATe] <State>

```

Activates the selected signal.

Signals and power configuration per satellite

Parameters:

<State> 1 | ON | 0 | OFF
 *RST: 0

Example:

See [Example "To configure SV power and modulation control"](#) on page 448.

Manual operation: See ["Signal State"](#) on page 89

```

[:SOURce<hw>]:BB:GNSS:SVID<ch>:SBAS:SIGNal:L5Band:EL5S:DATA:PCODE[:
  STATE] <State>
[:SOURce<hw>]:BB:GNSS:SVID<ch>:SBAS:SIGNal:L1Band:CA:DATA:PCODE[:
  STATE] <State>
[:SOURce<hw>]:BB:GNSS:SVID<ch>:NAVic:SIGNal:L5Band:SPS:DATA:PCODE[:
  STATE] <State>
[:SOURce<hw>]:BB:GNSS:SVID<ch>:QZSS:SIGNal:L5Band:L5S:DATA:PCODE[:
  STATE] <State>
[:SOURce<hw>]:BB:GNSS:SVID<ch>:QZSS:SIGNal:L5Band:L5S:PILot:PCODE[:
  STATE] <State>
[:SOURce<hw>]:BB:GNSS:SVID<ch>:QZSS:SIGNal:L2Band:L2C:DATA:PCODE[:
  STATE] <State>
[:SOURce<hw>]:BB:GNSS:SVID<ch>:QZSS:SIGNal:L2Band:L2C:PILot:PCODE[:
  STATE] <State>
[:SOURce<hw>]:BB:GNSS:SVID<ch>:QZSS:SIGNal:L1Band:L1C:DATA:PCODE[:
  STATE] <State>
[:SOURce<hw>]:BB:GNSS:SVID<ch>:QZSS:SIGNal:L1Band:L1C:PILot:PCODE[:
  STATE] <State>
[:SOURce<hw>]:BB:GNSS:SVID<ch>:QZSS:SIGNal:L1Band:CA:DATA:PCODE[:
  STATE] <State>
[:SOURce<hw>]:BB:GNSS:SVID<ch>:QZSS:SIGNal:L1Band:CA:PILot:PCODE[:
  STATE] <State>
[:SOURce<hw>]:BB:GNSS:SVID<ch>:BEIDou:SIGNal:L5Band:B2I:DATA:PCODE[:
  STATE] <State>
[:SOURce<hw>]:BB:GNSS:SVID<ch>:BEIDou:SIGNal:L5Band:B2A:DATA:
  PCODE[:STATE] <State>
[:SOURce<hw>]:BB:GNSS:SVID<ch>:BEIDou:SIGNal:L5Band:B2A:PILot:
  PCODE[:STATE] <State>
[:SOURce<hw>]:BB:GNSS:SVID<ch>:BEIDou:SIGNal:L5Band:B2B:DATA:
  PCODE[:STATE] <State>
[:SOURce<hw>]:BB:GNSS:SVID<ch>:BEIDou:SIGNal:L2Band:B3I:DATA:PCODE[:
  STATE] <State>
[:SOURce<hw>]:BB:GNSS:SVID<ch>:BEIDou:SIGNal:L1Band:B1C:PILot:
  PCODE[:STATE] <State>
[:SOURce<hw>]:BB:GNSS:SVID<ch>:BEIDou:SIGNal:L1Band:B1I:DATA:PCODE[:
  STATE] <State>
[:SOURce<hw>]:BB:GNSS:SVID<ch>:BEIDou:SIGNal:L1Band:B1I:PILot:PCODE[:
  STATE] <State>
[:SOURce<hw>]:BB:GNSS:SVID<ch>:BEIDou:SIGNal:L1Band:B1C:DATA:
  PCODE[:STATE] <State>

```

```

[:SOURce<hw>]:BB:GNSS:SVID<ch>:GLONass:SIGNal:L5Band:L3CDma:DATA:
  PCODE[:STATe] <State>
[:SOURce<hw>]:BB:GNSS:SVID<ch>:GLONass:SIGNal:L5Band:L3CDma:PILot:
  PCODE[:STATe] <State>
[:SOURce<hw>]:BB:GNSS:SVID<ch>:GLONass:SIGNal:L2Band:L2CDma:PILot:
  PCODE[:STATe] <State>
[:SOURce<hw>]:BB:GNSS:SVID<ch>:GLONass:SIGNal:L2Band:CA:DATA:
  PCODE[:STATe] <State>
[:SOURce<hw>]:BB:GNSS:SVID<ch>:GLONass:SIGNal:L2Band:CA:PILot:
  PCODE[:STATe] <State>
[:SOURce<hw>]:BB:GNSS:SVID<ch>:GLONass:SIGNal:L1Band:L1CDma:DATA:
  PCODE[:STATe] <State>
[:SOURce<hw>]:BB:GNSS:SVID<ch>:GLONass:SIGNal:L1Band:L1CDma:PILot:
  PCODE[:STATe] <State>
[:SOURce<hw>]:BB:GNSS:SVID<ch>:GLONass:SIGNal:L1Band:CA:DATA:
  PCODE[:STATe] <State>
[:SOURce<hw>]:BB:GNSS:SVID<ch>:GLONass:SIGNal:L1Band:CA:PILot:
  PCODE[:STATe] <State>
[:SOURce<hw>]:BB:GNSS:SVID<ch>:GALileo:SIGNal:L5Band:E5B:DATA:
  PCODE[:STATe] <State>
[:SOURce<hw>]:BB:GNSS:SVID<ch>:GALileo:SIGNal:L5Band:E5B:PILot:
  PCODE[:STATe] <State>
[:SOURce<hw>]:BB:GNSS:SVID<ch>:GALileo:SIGNal:L5Band:E5A:DATA:
  PCODE[:STATe] <State>
[:SOURce<hw>]:BB:GNSS:SVID<ch>:GALileo:SIGNal:L5Band:E5A:PILot:
  PCODE[:STATe] <State>
[:SOURce<hw>]:BB:GNSS:SVID<ch>:GALileo:SIGNal:L2Band:E6PRs:DATA:
  PCODE[:STATe] <State>
[:SOURce<hw>]:BB:GNSS:SVID<ch>:GALileo:SIGNal:L2Band:E6S:DATA:
  PCODE[:STATe] <State>
[:SOURce<hw>]:BB:GNSS:SVID<ch>:GALileo:SIGNal:L2Band:E6S:PILot:
  PCODE[:STATe] <State>
[:SOURce<hw>]:BB:GNSS:SVID<ch>:GALileo:SIGNal:L1Band:E1OS:DATA:
  PCODE[:STATe] <State>
[:SOURce<hw>]:BB:GNSS:SVID<ch>:GALileo:SIGNal:L1Band:E1OS:PILot:
  PCODE[:STATe] <State>
[:SOURce<hw>]:BB:GNSS:SVID<ch>:GALileo:SIGNal:L1Band:E1PRs:DATA:
  PCODE[:STATe] <State>
[:SOURce<hw>]:BB:GNSS:SVID<ch>:GPS:SIGNal:L5Band:L5S:DATA:PCODE[:
  STATe] <State>
[:SOURce<hw>]:BB:GNSS:SVID<ch>:GPS:SIGNal:L5Band:L5S:PILot:PCODE[:
  STATe] <State>
[:SOURce<hw>]:BB:GNSS:SVID<ch>:GPS:SIGNal:L2Band:CA:DATA:PCODE[:
  STATe] <State>
[:SOURce<hw>]:BB:GNSS:SVID<ch>:GPS:SIGNal:L2Band:CA:PILot:PCODE[:
  STATe] <State>
[:SOURce<hw>]:BB:GNSS:SVID<ch>:GPS:SIGNal:L2Band:L2C:DATA:PCODE[:
  STATe] <State>
[:SOURce<hw>]:BB:GNSS:SVID<ch>:GPS:SIGNal:L2Band:L2C:PILot:PCODE[:
  STATe] <State>

```

```

[:SOURce<hw>]:BB:GNSS:SVID<ch>:GPS:SIGNal:L2Band:M:DATA:PCODE[:
  STATE] <State>
[:SOURce<hw>]:BB:GNSS:SVID<ch>:GPS:SIGNal:L2Band:P:DATA:PCODE[:
  STATE] <State>
[:SOURce<hw>]:BB:GNSS:SVID<ch>:GPS:SIGNal:L2Band:P:PILot:PCODE[:
  STATE] <State>
[:SOURce<hw>]:BB:GNSS:SVID<ch>:GPS:SIGNal:L2Band:PY:DATA:PCODE[:
  STATE] <State>
[:SOURce<hw>]:BB:GNSS:SVID<ch>:GPS:SIGNal:L1Band:L1C:DATA:PCODE[:
  STATE] <State>
[:SOURce<hw>]:BB:GNSS:SVID<ch>:GPS:SIGNal:L1Band:L1C:PILot:PCODE[:
  STATE] <State>
[:SOURce<hw>]:BB:GNSS:SVID<ch>:GPS:SIGNal:L1Band:M:DATA:PCODE[:
  STATE] <State>
[:SOURce<hw>]:BB:GNSS:SVID<ch>:GPS:SIGNal:L1Band:P:DATA:PCODE[:
  STATE] <State>
[:SOURce<hw>]:BB:GNSS:SVID<ch>:GPS:SIGNal:L1Band:P:PILot:PCODE[:
  STATE] <State>
[:SOURce<hw>]:BB:GNSS:SVID<ch>:GPS:SIGNal:L1Band:PY:DATA:PCODE[:
  STATE] <State>
[:SOURce<hw>]:BB:GNSS:SVID<ch>:GPS:SIGNal:L1Band:CA:PILot:PCODE[:
  STATE] <State>
[:SOURce<hw>]:BB:GNSS:SVID<ch>:GPS:SIGNal:L1Band:CA:DATA:PCODE[:
  STATE] <State>

```

Activates spreading by using the primary code.

Parameters:

```

<State>          1 | ON | 0 | OFF
*RST:            1

```

Example: See [Example "To configure SV power and modulation control"](#) on page 448.

Manual operation: See ["Primary Code"](#) on page 90

```

[:SOURce<hw>]:BB:GNSS:SVID<ch>:QZSS:SIGNal:L5Band:L5S:DATA:SCODE[:
  STATE] <State>
[:SOURce<hw>]:BB:GNSS:SVID<ch>:QZSS:SIGNal:L5Band:L5S:PILot:SCODE[:
  STATE] <State>
[:SOURce<hw>]:BB:GNSS:SVID<ch>:QZSS:SIGNal:L1Band:L1C:PILot:SCODE[:
  STATE] <State>
[:SOURce<hw>]:BB:GNSS:SVID<ch>:BEIDou:SIGNal:L5Band:B2A:DATA:
  SCODE[:STATE] <State>
[:SOURce<hw>]:BB:GNSS:SVID<ch>:BEIDou:SIGNal:L5Band:B2A:PILot:
  SCODE[:STATE] <State>
[:SOURce<hw>]:BB:GNSS:SVID<ch>:BEIDou:SIGNal:L5Band:B2I:DATA:SCODE[:
  STATE] <State>
[:SOURce<hw>]:BB:GNSS:SVID<ch>:BEIDou:SIGNal:L2Band:B3I:DATA:SCODE[:
  STATE] <State>

```

Signals and power configuration per satellite

```

[:SOURce<hw>]:BB:GNSS:SVID<ch>:BEIDou:SIGNal:L1Band:B1C:PILot:
  SCODE[:STATe] <State>
[:SOURce<hw>]:BB:GNSS:SVID<ch>:BEIDou:SIGNal:L1Band:B1I:DATA:SCODE[:
  STATe] <State>
[:SOURce<hw>]:BB:GNSS:SVID<ch>:BEIDou:SIGNal:L1Band:B1I:PILot:SCODE[:
  STATe] <State>
[:SOURce<hw>]:BB:GNSS:SVID<ch>:GLONass:SIGNal:L5Band:L3CDma:DATA:
  SCODE[:STATe] <State>
[:SOURce<hw>]:BB:GNSS:SVID<ch>:GLONass:SIGNal:L5Band:L3CDma:PILot:
  SCODE[:STATe] <State>
[:SOURce<hw>]:BB:GNSS:SVID<ch>:GLONass:SIGNal:L2Band:L2CDma:PILot:
  SCODE[:STATe] <State>
[:SOURce<hw>]:BB:GNSS:SVID<ch>:GLONass:SIGNal:L1Band:L1CDma:DATA:
  SCODE[:STATe] <State>
[:SOURce<hw>]:BB:GNSS:SVID<ch>:GALileo:SIGNal:L5Band:E5B:DATA:
  SCODE[:STATe] <State>
[:SOURce<hw>]:BB:GNSS:SVID<ch>:GALileo:SIGNal:L5Band:E5B:PILot:
  SCODE[:STATe] <State>
[:SOURce<hw>]:BB:GNSS:SVID<ch>:GALileo:SIGNal:L5Band:E5A:DATA:
  SCODE[:STATe] <State>
[:SOURce<hw>]:BB:GNSS:SVID<ch>:GALileo:SIGNal:L5Band:E5A:PILot:
  SCODE[:STATe] <State>
[:SOURce<hw>]:BB:GNSS:SVID<ch>:GALileo:SIGNal:L2Band:E6PRs:DATA:
  SCODE[:STATe] <State>
[:SOURce<hw>]:BB:GNSS:SVID<ch>:GALileo:SIGNal:L2Band:E6S:PILot:
  SCODE[:STATe] <State>
[:SOURce<hw>]:BB:GNSS:SVID<ch>:GALileo:SIGNal:L1Band:E1OS:DATA:
  SCODE[:STATe] <State>
[:SOURce<hw>]:BB:GNSS:SVID<ch>:GALileo:SIGNal:L1Band:E1OS:PILot:
  SCODE[:STATe] <State>
[:SOURce<hw>]:BB:GNSS:SVID<ch>:GALileo:SIGNal:L1Band:E1PRs:DATA:
  SCODE[:STATe] <State>
[:SOURce<hw>]:BB:GNSS:SVID<ch>:GPS:SIGNal:L5Band:L5S:DATA:SCODE[:
  STATe] <State>
[:SOURce<hw>]:BB:GNSS:SVID<ch>:GPS:SIGNal:L5Band:L5S:PILot:SCODE[:
  STATe] <State>
[:SOURce<hw>]:BB:GNSS:SVID<ch>:GPS:SIGNal:L2Band:M:DATA:SCODE[:
  STATe] <State>
[:SOURce<hw>]:BB:GNSS:SVID<ch>:GPS:SIGNal:L2Band:PY:DATA:SCODE[:
  STATe] <State>
[:SOURce<hw>]:BB:GNSS:SVID<ch>:GPS:SIGNal:L1Band:M:DATA:SCODE[:
  STATe] <State>
[:SOURce<hw>]:BB:GNSS:SVID<ch>:GPS:SIGNal:L1Band:PY:DATA:SCODE[:
  STATe] <State>
[:SOURce<hw>]:BB:GNSS:SVID<ch>:GPS:SIGNal:L1Band:L1C:PILot:SCODE[:
  STATe] <State>

```

Activates the secondary code in the data/pilot channel.

Parameters:

<State> 1 | ON | 0 | OFF
 *RST: 1

Example:

```
SOURce1:BB:GNSS:SYSTEM:GPS:STATE 1
SOURce1:BB:GNSS:SVID1:GPS:SIGNal:L1Band:L1C 1
SOURce1:BB:GNSS:SVID1:GPS:SIGNal:L5Band:L5S 1
SOURce1:BB:GNSS:SVID1:GPS:SIGNal:L1Band:L1C:PIlot:SCODE 1
SOURce1:BB:GNSS:SVID1:GPS:SIGNal:L5Band:L5S:PIlot:SCODE 1
SOURce1:BB:GNSS:SVID1:GPS:SIGNal:L5Band:L5S:DATA:SCODE 1
```

Example:

See [Example "To configure SV power and modulation control"](#) on page 448.

Manual operation: See ["Secondary Code"](#) on page 90

```
[:SOURce<hw>]:BB:GNSS:SVID<ch>:SBAS:SIGNal:L5Band:EL5S:DATA:
  NMESsage:CONTrol <NavMsgControl>
[:SOURce<hw>]:BB:GNSS:SVID<ch>:SBAS:SIGNal:L1Band:CA:DATA:
  NMESsage:CONTrol <NavMsgControl>
[:SOURce<hw>]:BB:GNSS:SVID<ch>:NAVic:SIGNal:L5Band:SPS:DATA:
  NMESsage:CONTrol <NavMsgControl>
[:SOURce<hw>]:BB:GNSS:SVID<ch>:QZSS:SIGNal:L5Band:L5S:DATA:
  NMESsage:CONTrol <NavMsgControl>
[:SOURce<hw>]:BB:GNSS:SVID<ch>:QZSS:SIGNal:L2Band:L2C:DATA:
  NMESsage:CONTrol <NavMsgControl>
[:SOURce<hw>]:BB:GNSS:SVID<ch>:QZSS:SIGNal:L1Band:L1C:DATA:
  NMESsage:CONTrol <NavMsgControl>
[:SOURce<hw>]:BB:GNSS:SVID<ch>:QZSS:SIGNal:L1Band:CA:DATA:
  NMESsage:CONTrol <NavMsgControl>
[:SOURce<hw>]:BB:GNSS:SVID<ch>:BEIDou:SIGNal:L5Band:B2A:DATA:
  NMESsage:CONTrol <NavMsgControl>
[:SOURce<hw>]:BB:GNSS:SVID<ch>:BEIDou:SIGNal:L5Band:B2B:DATA:
  NMESsage:CONTrol <NavMsgControl>
[:SOURce<hw>]:BB:GNSS:SVID<ch>:BEIDou:SIGNal:L5Band:B2I:DATA:
  NMESsage:CONTrol <NavMsgControl>
[:SOURce<hw>]:BB:GNSS:SVID<ch>:BEIDou:SIGNal:L2Band:B3I:DATA:
  NMESsage:CONTrol <NavMsgControl>
[:SOURce<hw>]:BB:GNSS:SVID<ch>:BEIDou:SIGNal:L1Band:B1C:DATA:
  NMESsage:CONTrol <NavMsgControl>
[:SOURce<hw>]:BB:GNSS:SVID<ch>:BEIDou:SIGNal:L1Band:B1I:DATA:
  NMESsage:CONTrol <NavMsgControl>
[:SOURce<hw>]:BB:GNSS:SVID<ch>:GLONass:SIGNal:L5Band:L3CDma:DATA:
  NMESsage:CONTrol <NavMsgControl>
[:SOURce<hw>]:BB:GNSS:SVID<ch>:GLONass:SIGNal:L2Band:CA:DATA:
  NMESsage:CONTrol <NavMsgControl>
[:SOURce<hw>]:BB:GNSS:SVID<ch>:GLONass:SIGNal:L2Band:L2CDma:DATA:
  NMESsage:CONTrol <NavMsgControl>
[:SOURce<hw>]:BB:GNSS:SVID<ch>:GLONass:SIGNal:L1Band:CA:DATA:
  NMESsage:CONTrol <NavMsgControl>
```

Signals and power configuration per satellite

```

[:SOURce<hw>]:BB:GNSS:SVID<ch>:GLONass:SIGNal:L1Band:L1CDma:DATA:
  NMESsage:CONTrol <NavMsgControl>
[:SOURce<hw>]:BB:GNSS:SVID<ch>:GALileo:SIGNal:L5Band:E5A:DATA:
  NMESsage:CONTrol <NavMsgControl>
[:SOURce<hw>]:BB:GNSS:SVID<ch>:GALileo:SIGNal:L5Band:E5B:DATA:
  NMESsage:CONTrol <NavMsgControl>
[:SOURce<hw>]:BB:GNSS:SVID<ch>:GALileo:SIGNal:L2Band:E6PRs:DATA:
  NMESsage:CONTrol <NavMsgControl>
[:SOURce<hw>]:BB:GNSS:SVID<ch>:GALileo:SIGNal:L2Band:E6S:DATA:
  NMESsage:CONTrol <NavMsgControl>
[:SOURce<hw>]:BB:GNSS:SVID<ch>:GALileo:SIGNal:L1Band:E1OS:DATA:
  NMESsage:CONTrol <NavMsgControl>
[:SOURce<hw>]:BB:GNSS:SVID<ch>:GALileo:SIGNal:L1Band:E1PRs:DATA:
  NMESsage:CONTrol <NavMsgControl>
[:SOURce<hw>]:BB:GNSS:SVID<ch>:GPS:SIGNal:L5Band:L5S:DATA:NMESsage:
  CONTrol <NavMsgControl>
[:SOURce<hw>]:BB:GNSS:SVID<ch>:GPS:SIGNal:L2Band:CA:DATA:NMESsage:
  CONTrol <NavMsgControl>
[:SOURce<hw>]:BB:GNSS:SVID<ch>:GPS:SIGNal:L2Band:L2C:DATA:
  NMESsage:CONTrol <NavMsgControl>
[:SOURce<hw>]:BB:GNSS:SVID<ch>:GPS:SIGNal:L2Band:M:DATA:NMESsage:
  CONTrol <NavMsgControl>
[:SOURce<hw>]:BB:GNSS:SVID<ch>:GPS:SIGNal:L2Band:P:DATA:NMESsage:
  CONTrol <NavMsgControl>
[:SOURce<hw>]:BB:GNSS:SVID<ch>:GPS:SIGNal:L2Band:PY:DATA:NMESsage:
  CONTrol <NavMsgControl>
[:SOURce<hw>]:BB:GNSS:SVID<ch>:GPS:SIGNal:L1Band:L1C:DATA:
  NMESsage:CONTrol <NavMsgControl>
[:SOURce<hw>]:BB:GNSS:SVID<ch>:GPS:SIGNal:L1Band:M:DATA:NMESsage:
  CONTrol <NavMsgControl>
[:SOURce<hw>]:BB:GNSS:SVID<ch>:GPS:SIGNal:L1Band:P:DATA:NMESsage:
  CONTrol <NavMsgControl>
[:SOURce<hw>]:BB:GNSS:SVID<ch>:GPS:SIGNal:L1Band:PY:DATA:NMESsage:
  CONTrol <NavMsgControl>
[:SOURce<hw>]:BB:GNSS:SVID<ch>:GPS:SIGNal:L1Band:CA:DATA:NMESsage:
  CONTrol <NavMsgControl>

```

Defines whether the navigation message parameters can be changed or not.

Parameters:

```

<NavMsgControl>  OFF | EDIT | AUTO | OFF | EDIT | AUTO
OFF
Disables sending the navigation message.
EDIT
Enables configuration of the navigation message.
AUTO
Navigation message is generated automatically.
*RST:           AUTO

```

Example: See [Example "To configure SV power and modulation control"](#) on page 448.

Manual operation: See ["Nav Msg Control"](#) on page 90

```

[:SOURCE<hw>]:BB:GNSS:SVID<ch>:SBAS:SIGNal:L5Band:EL5S:DATA:
  NMESsage:TYPE <Data>
[:SOURCE<hw>]:BB:GNSS:SVID<ch>:SBAS:SIGNal:L1Band:CA:DATA:
  NMESsage:TYPE <Data>
[:SOURCE<hw>]:BB:GNSS:SVID<ch>:NAVic:SIGNal:L5Band:SPS:DATA:
  NMESsage:TYPE <Data>
[:SOURCE<hw>]:BB:GNSS:SVID<ch>:QZSS:SIGNal:L5Band:L5S:DATA:
  NMESsage:TYPE <Data>
[:SOURCE<hw>]:BB:GNSS:SVID<ch>:QZSS:SIGNal:L2Band:L2C:DATA:
  NMESsage:TYPE <Data>
[:SOURCE<hw>]:BB:GNSS:SVID<ch>:QZSS:SIGNal:L1Band:CA:DATA:
  NMESsage:TYPE <Data>
[:SOURCE<hw>]:BB:GNSS:SVID<ch>:QZSS:SIGNal:L1Band:L1C:DATA:
  NMESsage:TYPE <Data>
[:SOURCE<hw>]:BB:GNSS:SVID<ch>:BEIDou:SIGNal:L5Band:B2A:DATA:
  NMESsage:TYPE <Data>
[:SOURCE<hw>]:BB:GNSS:SVID<ch>:BEIDou:SIGNal:L5Band:B2B:DATA:
  NMESsage:TYPE <Data>
[:SOURCE<hw>]:BB:GNSS:SVID<ch>:BEIDou:SIGNal:L5Band:B2I:DATA:
  NMESsage:TYPE <Data>
[:SOURCE<hw>]:BB:GNSS:SVID<ch>:BEIDou:SIGNal:L2Band:B3I:DATA:
  NMESsage:TYPE <Data>
[:SOURCE<hw>]:BB:GNSS:SVID<ch>:BEIDou:SIGNal:L1Band:B1C:DATA:
  NMESsage:TYPE <Data>
[:SOURCE<hw>]:BB:GNSS:SVID<ch>:BEIDou:SIGNal:L1Band:B1I:DATA:
  NMESsage:TYPE <Data>
[:SOURCE<hw>]:BB:GNSS:SVID<ch>:GLONass:SIGNal:L5Band:L3CDma:DATA:
  NMESsage:TYPE <Data>
[:SOURCE<hw>]:BB:GNSS:SVID<ch>:GLONass:SIGNal:L2Band:CA:DATA:
  NMESsage:TYPE <Data>
[:SOURCE<hw>]:BB:GNSS:SVID<ch>:GLONass:SIGNal:L2Band:L2CDma:DATA:
  NMESsage:TYPE <Data>
[:SOURCE<hw>]:BB:GNSS:SVID<ch>:GLONass:SIGNal:L1Band:CA:DATA:
  NMESsage:TYPE <Data>
[:SOURCE<hw>]:BB:GNSS:SVID<ch>:GLONass:SIGNal:L1Band:L1CDma:DATA:
  NMESsage:TYPE <Data>
[:SOURCE<hw>]:BB:GNSS:SVID<ch>:GALileo:SIGNal:L5Band:E5A:DATA:
  NMESsage:TYPE <Data>
[:SOURCE<hw>]:BB:GNSS:SVID<ch>:GALileo:SIGNal:L5Band:E5B:DATA:
  NMESsage:TYPE <Data>
[:SOURCE<hw>]:BB:GNSS:SVID<ch>:GALileo:SIGNal:L2Band:E6PRs:DATA:
  NMESsage:TYPE <Data>
[:SOURCE<hw>]:BB:GNSS:SVID<ch>:GALileo:SIGNal:L2Band:E6S:DATA:
  NMESsage:TYPE <Data>

```

Signals and power configuration per satellite

```

[:SOURce<hw>]:BB:GNSS:SVID<ch>:GALileo:SIGNal:L1Band:E1OS:DATA:
  NMEssage:TYPE <Data>
[:SOURce<hw>]:BB:GNSS:SVID<ch>:GALileo:SIGNal:L1Band:E1PRs:DATA:
  NMEssage:TYPE <Data>
[:SOURce<hw>]:BB:GNSS:SVID<ch>:GPS:SIGNal:L5Band:L5S:DATA:NMEssage:
  TYPE <Data>
[:SOURce<hw>]:BB:GNSS:SVID<ch>:GPS:SIGNal:L2Band:CA:DATA:NMEssage:
  TYPE <Data>
[:SOURce<hw>]:BB:GNSS:SVID<ch>:GPS:SIGNal:L2Band:L2C:DATA:
  NMEssage:TYPE <Data>
[:SOURce<hw>]:BB:GNSS:SVID<ch>:GPS:SIGNal:L2Band:M:DATA:NMEssage:
  TYPE <Data>
[:SOURce<hw>]:BB:GNSS:SVID<ch>:GPS:SIGNal:L2Band:P:DATA:NMEssage:
  TYPE <Data>
[:SOURce<hw>]:BB:GNSS:SVID<ch>:GPS:SIGNal:L2Band:PY:DATA:NMEssage:
  TYPE <Data>
[:SOURce<hw>]:BB:GNSS:SVID<ch>:GPS:SIGNal:L1Band:L1C:DATA:
  NMEssage:TYPE <Data>
[:SOURce<hw>]:BB:GNSS:SVID<ch>:GPS:SIGNal:L1Band:M:DATA:NMEssage:
  TYPE <Data>
[:SOURce<hw>]:BB:GNSS:SVID<ch>:GPS:SIGNal:L1Band:P:DATA:NMEssage:
  TYPE <Data>
[:SOURce<hw>]:BB:GNSS:SVID<ch>:GPS:SIGNal:L1Band:PY:DATA:NMEssage:
  TYPE <Data>
[:SOURce<hw>]:BB:GNSS:SVID<ch>:GPS:SIGNal:L1Band:CA:DATA:NMEssage:
  TYPE <Data>

```

Sets the data source used for the generation of the navigation message.

Parameters:

<Data> ZERO | ONE | PATtern | PN9 | PN11 | PN15 | PN16 | PN20 |
 PN21 | PN23 | DLISt | RNDData | ZNDData

**ZERO|ONE|PATtern|PN9|PN11|PN15|PN16|PN20|PN21|PN23|
 DLISt**
 Arbitrary data source.
 Define the pattern and load an existing data list file with the com-
 mands:

```

[:SOURce<hw>]:BB:GNSS:SVID<ch>:GPS:SIGNal:
L1Band:CA:DATA:NMEssage:PATtern
[:SOURce<hw>]:BB:GNSS:SVID<ch>:GPS:SIGNal:
L1Band:CA:DATA:NMEssage:DSElect

```

RNDData
 Summary indication for real navigation data.
 Current navigation message type depends on the GNSS system
 and the RF band, e.g. for GPS in L1 RNDData means LNAV.

ZNDData
 Zero navigation data
 Sets the orbit and clock correction parameters in the broadcas-
 ted navigation message to zero.

*RST: RNDData

Example: See [Example "To configure SV power and modulation control"](#) on page 448.

Manual operation: See ["Nav Msg Type"](#) on page 91

```

[:SOURce<hw>]:BB:GNSS:SVID<ch>:SBAS:SIGNal:L5Band:EL5S:DATA:
  NMESsage:DSElect <DSelect>
[:SOURce<hw>]:BB:GNSS:SVID<ch>:SBAS:SIGNal:L1Band:CA:DATA:
  NMESsage:DSElect <DSelect>
[:SOURce<hw>]:BB:GNSS:SVID<ch>:NAVic:SIGNal:L5Band:SPS:DATA:
  NMESsage:DSElect <DSelect>
[:SOURce<hw>]:BB:GNSS:SVID<ch>:QZSS:SIGNal:L5Band:L5S:DATA:
  NMESsage:DSElect <DSelect>
[:SOURce<hw>]:BB:GNSS:SVID<ch>:QZSS:SIGNal:L2Band:L2C:DATA:
  NMESsage:DSElect <DSelect>
[:SOURce<hw>]:BB:GNSS:SVID<ch>:QZSS:SIGNal:L1Band:CA:DATA:
  NMESsage:DSElect <DSelect>
[:SOURce<hw>]:BB:GNSS:SVID<ch>:QZSS:SIGNal:L1Band:L1C:DATA:
  NMESsage:DSElect <DSelect>
[:SOURce<hw>]:BB:GNSS:SVID<ch>:BEIDou:SIGNal:L5Band:B2A:DATA:
  NMESsage:DSElect <DSelect>
[:SOURce<hw>]:BB:GNSS:SVID<ch>:BEIDou:SIGNal:L5Band:B2B:DATA:
  NMESsage:DSElect <DSelect>
[:SOURce<hw>]:BB:GNSS:SVID<ch>:BEIDou:SIGNal:L5Band:B2I:DATA:
  NMESsage:DSElect <DSelect>
[:SOURce<hw>]:BB:GNSS:SVID<ch>:BEIDou:SIGNal:L2Band:B3I:DATA:
  NMESsage:DSElect <DSelect>
[:SOURce<hw>]:BB:GNSS:SVID<ch>:BEIDou:SIGNal:L1Band:B1C:DATA:
  NMESsage:DSElect <DSelect>
[:SOURce<hw>]:BB:GNSS:SVID<ch>:BEIDou:SIGNal:L1Band:B1I:DATA:
  NMESsage:DSElect <DSelect>
[:SOURce<hw>]:BB:GNSS:SVID<ch>:GLONass:SIGNal:L5Band:L3CDma:DATA:
  NMESsage:DSElect <DSelect>
[:SOURce<hw>]:BB:GNSS:SVID<ch>:GLONass:SIGNal:L2Band:CA:DATA:
  NMESsage:DSElect <DSelect>
[:SOURce<hw>]:BB:GNSS:SVID<ch>:GLONass:SIGNal:L2Band:L2CDma:DATA:
  NMESsage:DSElect <DSelect>
[:SOURce<hw>]:BB:GNSS:SVID<ch>:GLONass:SIGNal:L1Band:CA:DATA:
  NMESsage:DSElect <DSelect>
[:SOURce<hw>]:BB:GNSS:SVID<ch>:GLONass:SIGNal:L1Band:L1CDma:DATA:
  NMESsage:DSElect <DSelect>
[:SOURce<hw>]:BB:GNSS:SVID<ch>:GALileo:SIGNal:L5Band:E5A:DATA:
  NMESsage:DSElect <DSelect>
[:SOURce<hw>]:BB:GNSS:SVID<ch>:GALileo:SIGNal:L5Band:E5B:DATA:
  NMESsage:DSElect <DSelect>
[:SOURce<hw>]:BB:GNSS:SVID<ch>:GALileo:SIGNal:L2Band:E6PRs:DATA:
  NMESsage:DSElect <DSelect>
[:SOURce<hw>]:BB:GNSS:SVID<ch>:GALileo:SIGNal:L2Band:E6S:DATA:
  NMESsage:DSElect <DSelect>

```

```

[:SOURce<hw>]:BB:GNSS:SVID<ch>:GALileo:SIGNal:L1Band:E1OS:DATA:
  NMEssage:DSElect <DSelect>
[:SOURce<hw>]:BB:GNSS:SVID<ch>:GALileo:SIGNal:L1Band:E1PRs:DATA:
  NMEssage:DSElect <DSelect>
[:SOURce<hw>]:BB:GNSS:SVID<ch>:GPS:SIGNal:L5Band:L5S:DATA:NMEssage:
  DSElect <DSelect>
[:SOURce<hw>]:BB:GNSS:SVID<ch>:GPS:SIGNal:L2Band:CA:DATA:NMEssage:
  DSElect <DSelect>
[:SOURce<hw>]:BB:GNSS:SVID<ch>:GPS:SIGNal:L2Band:L2C:DATA:
  NMEssage:DSElect <DSelect>
[:SOURce<hw>]:BB:GNSS:SVID<ch>:GPS:SIGNal:L2Band:M:DATA:NMEssage:
  DSElect <DSelect>
[:SOURce<hw>]:BB:GNSS:SVID<ch>:GPS:SIGNal:L2Band:P:DATA:NMEssage:
  DSElect <DSelect>
[:SOURce<hw>]:BB:GNSS:SVID<ch>:GPS:SIGNal:L2Band:PY:DATA:NMEssage:
  DSElect <DSelect>
[:SOURce<hw>]:BB:GNSS:SVID<ch>:GPS:SIGNal:L1Band:L1C:DATA:
  NMEssage:DSElect <DSelect>
[:SOURce<hw>]:BB:GNSS:SVID<ch>:GPS:SIGNal:L1Band:M:DATA:NMEssage:
  DSElect <DSelect>
[:SOURce<hw>]:BB:GNSS:SVID<ch>:GPS:SIGNal:L1Band:P:DATA:NMEssage:
  DSElect <DSelect>
[:SOURce<hw>]:BB:GNSS:SVID<ch>:GPS:SIGNal:L1Band:PY:DATA:NMEssage:
  DSElect <DSelect>
[:SOURce<hw>]:BB:GNSS:SVID<ch>:GPS:SIGNal:L1Band:CA:DATA:NMEssage:
  DSElect <DSelect>

```

Selects an existing data list file from the default directory or from the specific directory.

Parameters:

<DSelect> string
 Filename incl. file extension or complete file path

Example: See [Example "To configure SV power and modulation control"](#) on page 448.

Manual operation: See ["Nav Msg Type"](#) on page 91

```

[:SOURce<hw>]:BB:GNSS:SVID<ch>:GALileo:SIGNal:L1Band:E1OS:DATA:
  OSNMa[:STATe] <State>

```

Activates OSNMA coding of net content of the Galileo navigation message.

Parameters:

<State> 1 | ON | 0 | OFF
 *RST: 0

Example: See [Example "To load a Galileo OSNMA scenario"](#) on page 448.

Manual operation: See ["OSNMA"](#) on page 180

```

[:SOURce<hw>]:BB:GNSS:SVID<ch>:SBAS:SIGNal:L5Band:EL5S:DATA:
    NMESsage:PATtern <Pattern>
[:SOURce<hw>]:BB:GNSS:SVID<ch>:SBAS:SIGNal:L1Band:CA:DATA:
    NMESsage:PATtern <Pattern>
[:SOURce<hw>]:BB:GNSS:SVID<ch>:NAVic:SIGNal:L5Band:SPS:DATA:
    NMESsage:PATtern <Pattern>
[:SOURce<hw>]:BB:GNSS:SVID<ch>:QZSS:SIGNal:L5Band:L5S:DATA:
    NMESsage:PATtern <Pattern>
[:SOURce<hw>]:BB:GNSS:SVID<ch>:QZSS:SIGNal:L2Band:L2C:DATA:
    NMESsage:PATtern <Pattern>
[:SOURce<hw>]:BB:GNSS:SVID<ch>:QZSS:SIGNal:L1Band:CA:DATA:
    NMESsage:PATtern <Pattern>
[:SOURce<hw>]:BB:GNSS:SVID<ch>:QZSS:SIGNal:L1Band:L1C:DATA:
    NMESsage:PATtern <Pattern>
[:SOURce<hw>]:BB:GNSS:SVID<ch>:BEIDou:SIGNal:L5Band:B2A:DATA:
    NMESsage:PATtern <Pattern>
[:SOURce<hw>]:BB:GNSS:SVID<ch>:BEIDou:SIGNal:L5Band:B2B:DATA:
    NMESsage:PATtern <Pattern>
[:SOURce<hw>]:BB:GNSS:SVID<ch>:BEIDou:SIGNal:L5Band:B2I:DATA:
    NMESsage:PATtern <Pattern>
[:SOURce<hw>]:BB:GNSS:SVID<ch>:BEIDou:SIGNal:L2Band:B3I:DATA:
    NMESsage:PATtern <Pattern>
[:SOURce<hw>]:BB:GNSS:SVID<ch>:BEIDou:SIGNal:L1Band:B1C:DATA:
    NMESsage:PATtern <Pattern>
[:SOURce<hw>]:BB:GNSS:SVID<ch>:BEIDou:SIGNal:L1Band:B1I:DATA:
    NMESsage:PATtern <Pattern>
[:SOURce<hw>]:BB:GNSS:SVID<ch>:GLONass:SIGNal:L5Band:L3CDma:DATA:
    NMESsage:PATtern <Pattern>
[:SOURce<hw>]:BB:GNSS:SVID<ch>:GLONass:SIGNal:L2Band:CA:DATA:
    NMESsage:PATtern <Pattern>
[:SOURce<hw>]:BB:GNSS:SVID<ch>:GLONass:SIGNal:L2Band:L2CDma:DATA:
    NMESsage:PATtern <Pattern>
[:SOURce<hw>]:BB:GNSS:SVID<ch>:GLONass:SIGNal:L1Band:CA:DATA:
    NMESsage:PATtern <Pattern>
[:SOURce<hw>]:BB:GNSS:SVID<ch>:GLONass:SIGNal:L1Band:L1CDma:DATA:
    NMESsage:PATtern <Pattern>
[:SOURce<hw>]:BB:GNSS:SVID<ch>:GALileo:SIGNal:L5Band:E5A:DATA:
    NMESsage:PATtern <Pattern>
[:SOURce<hw>]:BB:GNSS:SVID<ch>:GALileo:SIGNal:L5Band:E5B:DATA:
    NMESsage:PATtern <Pattern>
[:SOURce<hw>]:BB:GNSS:SVID<ch>:GALileo:SIGNal:L2Band:E6PRs:DATA:
    NMESsage:PATtern <Pattern>
[:SOURce<hw>]:BB:GNSS:SVID<ch>:GALileo:SIGNal:L2Band:E6S:DATA:
    NMESsage:PATtern <Pattern>
[:SOURce<hw>]:BB:GNSS:SVID<ch>:GALileo:SIGNal:L1Band:E1OS:DATA:
    NMESsage:PATtern <Pattern>
[:SOURce<hw>]:BB:GNSS:SVID<ch>:GALileo:SIGNal:L1Band:E1PRs:DATA:
    NMESsage:PATtern <Pattern>

```

Signals and power configuration per satellite

```

[:SOURCE<hw>]:BB:GNSS:SVID<ch>:GPS:SIGNal:L5S:DATA:NMESSage:
  PATtern <Pattern>
[:SOURCE<hw>]:BB:GNSS:SVID<ch>:GPS:SIGNal:L2Band:CA:DATA:NMESSage:
  PATtern <Pattern>
[:SOURCE<hw>]:BB:GNSS:SVID<ch>:GPS:SIGNal:L2Band:L2C:DATA:
  NMESSage:PATtern <Pattern>
[:SOURCE<hw>]:BB:GNSS:SVID<ch>:GPS:SIGNal:L2Band:M:DATA:NMESSage:
  PATtern <Pattern>
[:SOURCE<hw>]:BB:GNSS:SVID<ch>:GPS:SIGNal:L2Band:P:DATA:NMESSage:
  PATtern <Pattern>
[:SOURCE<hw>]:BB:GNSS:SVID<ch>:GPS:SIGNal:L2Band:PY:DATA:NMESSage:
  PATtern <Pattern>
[:SOURCE<hw>]:BB:GNSS:SVID<ch>:GPS:SIGNal:L1Band:L1C:DATA:
  NMESSage:PATtern <Pattern>
[:SOURCE<hw>]:BB:GNSS:SVID<ch>:GPS:SIGNal:L1Band:M:DATA:NMESSage:
  PATtern <Pattern>
[:SOURCE<hw>]:BB:GNSS:SVID<ch>:GPS:SIGNal:L1Band:P:DATA:NMESSage:
  PATtern <Pattern>
[:SOURCE<hw>]:BB:GNSS:SVID<ch>:GPS:SIGNal:L1Band:PY:DATA:NMESSage:
  PATtern <Pattern>
[:SOURCE<hw>]:BB:GNSS:SVID<ch>:GPS:SIGNal:L1Band:CA:DATA:NMESSage:
  PATtern <Pattern>

```

Sets a bit pattern as data source.

Parameters:

<Pattern> 64 bits

Example: See [Example "To configure SV power and modulation control"](#) on page 448.

Manual operation: See ["Nav Msg Type"](#) on page 91

```

[:SOURCE<hw>]:BB:GNSS:SVID<ch>:GLONass:SIGNal:L2Band:CA:DATA:
  MEANdering[:STATE] <State>
[:SOURCE<hw>]:BB:GNSS:SVID<ch>:GLONass:SIGNal:L1Band:CA:DATA:
  MEANdering[:STATE] <State>

```

Enables meandering, i.e. doubling the data rate of a GLONASS satellite navigation signal.

Parameters:

<State> 1 | ON | 0 | OFF
 *RST: 1

Example: See [\[:SOURCE<hw>\]:BB:GNSS:SVID<ch>:GLONass:SIGNal:L1Band:CA:DATA:TSEQUence\[:STATE\]](#) on page 477.

Manual operation: See ["Meander Sequence"](#) on page 92

```
[:SOURce<hw>]:BB:GNSS:SVID<ch>:GLONass:SIGNal:L2Band:CA:DATA:
TSEquence[:STATe] <State>
[:SOURce<hw>]:BB:GNSS:SVID<ch>:GLONass:SIGNal:L1Band:CA:DATA:
TSEquence[:STATe] <State>
```

Enables the time signal component of GLONASS signals.

Parameters:

```
<State>          1 | ON | 0 | OFF
*RST:           1
```

Example:

```
:SOURce1:BB:GNSS:SYSTem:GLONass:STATe 1
:SOURce1:BB:GNSS:SVID2:GLONass:SIGNal:L1Band:CA:DATA:MEANdering:STATe 1
:SOURce1:BB:GNSS:SVID2:GLONass:SIGNal:L1Band:CA:DATA:TSEquence:STATe 1
```

Manual operation: See ["Time Sequence"](#) on page 93

```
[:SOURce<hw>]:BB:GNSS:SVID<ch>:SBAS:MCONtrol:COpy:SVID <Svid>
[:SOURce<hw>]:BB:GNSS:SVID<ch>:NAVic:MCONtrol:COpy:SVID <Svid>
[:SOURce<hw>]:BB:GNSS:SVID<ch>:QZSS:MCONtrol:COpy:SVID <Svid>
[:SOURce<hw>]:BB:GNSS:SVID<ch>:BEIDou:MCONtrol:COpy:SVID <Svid>
[:SOURce<hw>]:BB:GNSS:SVID<ch>:GLONass:MCONtrol:COpy:SVID <Svid>
[:SOURce<hw>]:BB:GNSS:SVID<ch>:GALileo:MCONtrol:COpy:SVID <Svid>
[:SOURce<hw>]:BB:GNSS:SVID<ch>:GPS:MCONtrol:COpy:SVID <Svid>
```

Sets the SV ID to that the configuration form the current satellite (SVID<ch>) is applied.

Both SV IDs belong to the same GNSS system.

Parameters:

```
<Svid>          1 | 2 | 3 | 5 | 4 | 6 | 7 | 8 | 9 | 10 | 11 | 12 | 13 | 14 | 15 | 16 | 17 |
19 | 18 | 20 | 21 | 22 | 23 | 24 | 25 | 26 | 27 | 28 | 29 | 30 | 31 |
32 | 33 | 34 | 35 | 36 | 37 | 38 | 39 | 40 | 41 | 42 | 43 | 44 | 45 |
46 | 47 | 48 | 49 | 50 | 51 | 52 | 53 | 54 | 55 | 56 | 57 | 58 | 59 |
60 | 61 | 62 | 63 | 64 | 65 | 66 | 67 | 68 | 69 | 70 | 71 | 72 | 73 |
74 | 75 | 76 | 77 | 78 | 79 | 80 | 81 | 82 | 83 | 84 | 85 | 86 | 87 |
88 | 89 | 90 | 91 | 92 | 93 | 94 | 95 | 96 | 97 | 98 | 99 | 100 | 101 |
102 | 103 | 104 | 105 | 106 | 107 | 108 | 109 | 110 | 111 | 112 |
113 | 114 | 115 | 116 | 117 | 118 | 119 | 120 | 121 | 122 | 123 |
124 | 125 | 126 | 127 | 128 | 129 | 130 | 131 | 132 | 133 | 134 |
135 | 136 | 137 | 138 | 139 | 140 | 141 | 142 | 143 | 144 | 145 |
146 | 147 | 148 | 149 | 150 | 151 | 152 | 153 | 154 | 155 | 156 |
157 | 158 | 159 | 160 | 161 | 162 | 163 | 164 | 165 | 166 | 167 |
168 | 169 | 170 | 171 | 172 | 173 | 174 | 175 | 176 | 177 | 178 |
179 | 180 | 181 | 182 | 183 | 184 | 185 | 186 | 187 | 188 | 189 |
190 | 191 | 192 | 193 | 194 | 195 | 196 | 197 | 198 | 199 | 200 |
ALL
*RST:           1
```

Example:

See [Example "To configure SV power and modulation control"](#) on page 448.

Manual operation: See ["Copy Modulation Control Settings to,SV-ID"](#) on page 93

```
[ :SOURce<hw>]:BB:GNSS:SVID<ch>:SBAS:MCONtrol:COPI:EXECute
[:SOURce<hw>]:BB:GNSS:SVID<ch>:NAVic:MCONtrol:COPI:EXECute
[:SOURce<hw>]:BB:GNSS:SVID<ch>:QZSS:MCONtrol:COPI:EXECute
[:SOURce<hw>]:BB:GNSS:SVID<ch>:BEIDou:MCONtrol:COPI:EXECute
[:SOURce<hw>]:BB:GNSS:SVID<ch>:GLONass:MCONtrol:COPI:EXECute
[:SOURce<hw>]:BB:GNSS:SVID<ch>:GALileo:MCONtrol:COPI:EXECute
[:SOURce<hw>]:BB:GNSS:SVID<ch>:GPS:MCONtrol:COPI:EXECute
```

Applies the configuration of the current satellite (SVID<ch>:<GNSS system>) to the satellite defined with the command `[:SOURce<hw>]:BB:GNSS:SVID<ch>:GPS:MCONtrol:COPI:SVID`.

Both SV IDs belong to the same GNSS system.

Example: See [Example "To configure SV power and modulation control"](#) on page 448.

Usage: Event

Manual operation: See ["Copy Modulation Control Settings to,SV-ID"](#) on page 93

22.13 Navigation message commands

Example: Setting scaled or unscaled navigation message parameters

```
// Unscaled values imply, that commands with mnemonic "UNSCaled" are used.
SOURce1:BB:GNSS:SSValues 0
SOURce1:BB:GNSS:SVID1:GPS:NMESSage:LNAV:EPHemeris:TOE:UNSCaled 28800

// Scaled values imply, that commands without mnemonic "UNSCaled" are used.
SOURce1:BB:GNSS:SSValues 1
SOURce1:BB:GNSS:SVID1:GPS:NMESSage:LNAV:EPHemeris:TOE 1800
```

Example: Configuring a pseudorange error ramp

```
SOURce1:BB:GNSS:SVID1:GPS:STATe 1

SOURce1:BB:GNSS:SVID1:GPS:PRERrors:MODE PROF
SOURce1:BB:GNSS:SVID1:GPS:PRERrors:PROFile1:OFFSet 50
SOURce1:BB:GNSS:SVID1:GPS:PRERrors:PROFile1:REFerence 0
SOURce1:BB:GNSS:SVID1:GPS:PRERrors:PROFile1:VALue -10
SOURce1:BB:GNSS:SVID1:GPS:PRERrors:PROFile2:REFerence 5
SOURce1:BB:GNSS:SVID1:GPS:PRERrors:PROFile2:VALue 10
SOURce1:BB:GNSS:SVID1:GPS:PRERrors:PROFile3:REFerence 10
SOURce1:BB:GNSS:SVID1:GPS:PRERrors:PROFile3:VALue 20
SOURce1:BB:GNSS:SVID1:GPS:PRERrors:PROFile4:REFerence 15
SOURce1:BB:GNSS:SVID1:GPS:PRERrors:PROFile4:VALue 30
SOURce1:BB:GNSS:SVID1:GPS:PRERrors:PROFile5:REFerence 20
```

```

SOURCE1:BB:GNSS:SVID1:GPS:PRERrors:PROFile5:VALue 40
SOURCE1:BB:GNSS:SVID1:GPS:PRERrors:PROFile6:REFerence 25
SOURCE1:BB:GNSS:SVID1:GPS:PRERrors:PROFile6:VALue 50
SOURCE1:BB:GNSS:SVID1:GPS:PRERrors:PROFile:COUNT?
// Response: "6"
SOURCE1:BB:GNSS:SVID1:GPS:PRERrors:PROFile:APPend
SOURCE1:BB:GNSS:SVID1:GPS:PRERrors:PROFile:COUNT?
// Response: "7"
SOURCE1:BB:GNSS:SVID1:GPS:PRERrors:PROFile7:REFerence 30
SOURCE1:BB:GNSS:SVID1:GPS:PRERrors:PROFile7:VALue 30
SOURCE1:BB:GNSS:SVID1:GPS:PRERrors:PROFile7:DELete
// Apply the same profile to "SV-ID 5".
SOURCE1:BB:GNSS:SVID1:GPS:PRERrors:COpy:SVID 5
SOURCE1:BB:GNSS:SVID1:GPS:PRERrors:COpy:EXECute

```

Example: Loading pseudorange errors from a file

```

SOURCE1:BB:GNSS:SVID1:GPS:STATe 1

SOURCE1:BB:GNSS:PRERrors:CATalog?
// Response: "GPS_PRERORS"
// The file GPS_PRERORS.rs_perr is available.
SOURCE1:BB:GNSS:SVID1:GPS:PRERrors:MODE FILE
SOURCE1:BB:GNSS:SVID1:GPS:PRERrors:FILE GPS_PRERORS
// Loads the file GPS_PRERORS.rs_perr for GPS SVID1 pseudorange errors.
SOURCE1:BB:GNSS:SVID1:GPS:PRERrors:PROFile1:OFFSet 50

```

Example: Configuring Galileo Search-and-Rescue (SAR) data

The example illustrates how to configure Galileo SAR data.

```

// *****
// Enable Galileo system and nav. message configuration of, e.g., space vehicle 6.
// *****
SOURCE1:BB:GNSS:SYSTem:GALileo:STATe 1
SOURCE1:BB:GNSS:SVID6:GALileo:SIGNal:L1Band:E1OS:DATA:NMESsage:CONTRol EDIT
// *****
Configure long return link message (RLM) data.
// *****
// Set for long RLM data SAR mode.
SOURCE1:BB:GNSS:SVID6:GAL:NMES:INAV:EPH:SAR:MODE LRLM
// Set data bits of RLM parts 1 to 8.
SOURCE1:BB:GNSS:SVID6:GAL:NMES:INAV:EPH:SAR:RLM1 0
SOURCE1:BB:GNSS:SVID6:GAL:NMES:INAV:EPH:SAR:RLM2 1
SOURCE1:BB:GNSS:SVID6:GAL:NMES:INAV:EPH:SAR:RLM3 2
SOURCE1:BB:GNSS:SVID6:GAL:NMES:INAV:EPH:SAR:RLM4 3
SOURCE1:BB:GNSS:SVID6:GAL:NMES:INAV:EPH:SAR:RLM5 4
SOURCE1:BB:GNSS:SVID6:GAL:NMES:INAV:EPH:SAR:RLM6 5
SOURCE1:BB:GNSS:SVID6:GAL:NMES:INAV:EPH:SAR:RLM7 6
SOURCE1:BB:GNSS:SVID6:GAL:NMES:INAV:EPH:SAR:RLM8 1048575

```

```
// *****
// Configure spare data.
// *****
// Set for spare data SAR mode.
SOURCE1:BB:GNSS:SVID6:GAL:NMES:INAV:EPH:SAR:MODE SPARE
// Set the 21 bits of spare SAR data.
SOURCE1:BB:GNSS:SVID6:GAL:NMES:INAV:EPH:SAR:SPARE 699050
```

Commands:

- Simulated orbit, orbit perturbation and clock commands..... 480
- Pseudorange commands..... 491
- Orbit, clock, system, time conversion and ionospheric errors..... 500

22.13.1 Simulated orbit, orbit perturbation and clock commands

[:SOURCE<hw>]:BB:GNSS:SSValues.....	483
[:SOURCE<hw>]:BB:GNSS:SVID<ch>:SBAS:SIMulated:ORBit:YN.....	483
[:SOURCE<hw>]:BB:GNSS:SVID<ch>:SBAS:SIMulated:ORBit:YD.....	483
[:SOURCE<hw>]:BB:GNSS:SVID<ch>:SBAS:SIMulated:ORBit:ZN.....	483
[:SOURCE<hw>]:BB:GNSS:SVID<ch>:GLONass:SIMulated:ORBit:YN.....	483
[:SOURCE<hw>]:BB:GNSS:SVID<ch>:GLONass:SIMulated:ORBit:YD.....	483
[:SOURCE<hw>]:BB:GNSS:SVID<ch>:GLONass:SIMulated:ORBit:ZN.....	483
[:SOURCE<hw>]:BB:GNSS:SVID<ch>:SBAS:SIMulated:ORBit:XD.....	483
[:SOURCE<hw>]:BB:GNSS:SVID<ch>:SBAS:SIMulated:ORBit:YD.....	483
[:SOURCE<hw>]:BB:GNSS:SVID<ch>:SBAS:SIMulated:ORBit:ZD.....	483
[:SOURCE<hw>]:BB:GNSS:SVID<ch>:GLONass:SIMulated:ORBit:XD.....	483
[:SOURCE<hw>]:BB:GNSS:SVID<ch>:GLONass:SIMulated:ORBit:YD.....	484
[:SOURCE<hw>]:BB:GNSS:SVID<ch>:GLONass:SIMulated:ORBit:ZD.....	484
[:SOURCE<hw>]:BB:GNSS:SVID<ch>:SBAS:SIMulated:ORBit:XDD.....	484
[:SOURCE<hw>]:BB:GNSS:SVID<ch>:SBAS:SIMulated:ORBit:YDD.....	484
[:SOURCE<hw>]:BB:GNSS:SVID<ch>:SBAS:SIMulated:ORBit:ZDD.....	484
[:SOURCE<hw>]:BB:GNSS:SVID<ch>:GLONass:SIMulated:ORBit:XDD.....	484
[:SOURCE<hw>]:BB:GNSS:SVID<ch>:GLONass:SIMulated:ORBit:YDD.....	484
[:SOURCE<hw>]:BB:GNSS:SVID<ch>:GLONass:SIMulated:ORBit:ZDD.....	484
[:SOURCE<hw>]:BB:GNSS:SVID<ch>:NAVic:SIMulated:ORBit:WNOE.....	484
[:SOURCE<hw>]:BB:GNSS:SVID<ch>:QZSS:SIMulated:ORBit:WNOE.....	484
[:SOURCE<hw>]:BB:GNSS:SVID<ch>:GALileo:SIMulated:ORBit:WNOE.....	484
[:SOURCE<hw>]:BB:GNSS:SVID<ch>:BEIDou:SIMulated:ORBit:WNOE.....	484
[:SOURCE<hw>]:BB:GNSS:SVID<ch>:GPS:SIMulated:ORBit:WNOE.....	484
[:SOURCE<hw>]:BB:GNSS:SVID<ch>:NAVic:SIMulated:ORBit:TOE.....	484
[:SOURCE<hw>]:BB:GNSS:SVID<ch>:QZSS:SIMulated:ORBit:TOE.....	484
[:SOURCE<hw>]:BB:GNSS:SVID<ch>:GALileo:SIMulated:ORBit:TOE.....	484
[:SOURCE<hw>]:BB:GNSS:SVID<ch>:BEIDou:SIMulated:ORBit:TOE.....	484
[:SOURCE<hw>]:BB:GNSS:SVID<ch>:GPS:SIMulated:ORBit:TOE.....	484
[:SOURCE<hw>]:BB:GNSS:SVID<ch>:SBAS:SIMulated:ORBit:DATE.....	485
[:SOURCE<hw>]:BB:GNSS:SVID<ch>:SBAS:SIMulated:CLOCK:DATE.....	485
[:SOURCE<hw>]:BB:GNSS:SVID<ch>:GLONass:SIMulated:ORBit:DATE.....	485
[:SOURCE<hw>]:BB:GNSS:SVID<ch>:GLONass:SIMulated:CLOCK:DATE.....	485

Navigation message commands

[SOURce<hw>]:BB:GNSS:SVID<ch>:SBAS:SIMulated:ORBit:TIME.....	485
[SOURce<hw>]:BB:GNSS:SVID<ch>:SBAS:SIMulated:CLOCK:TIME.....	485
[SOURce<hw>]:BB:GNSS:SVID<ch>:GLONass:SIMulated:ORBit:TIME.....	485
[SOURce<hw>]:BB:GNSS:SVID<ch>:GLONass:SIMulated:CLOCK:TIME.....	485
[SOURce<hw>]:BB:GNSS:SVID<ch>:NAVic:SIMulated:ORBit:SQRA.....	485
[SOURce<hw>]:BB:GNSS:SVID<ch>:QZSS:SIMulated:ORBit:SQRA.....	485
[SOURce<hw>]:BB:GNSS:SVID<ch>:GALileo:SIMulated:ORBit:SQRA.....	486
[SOURce<hw>]:BB:GNSS:SVID<ch>:BEIDou:SIMulated:ORBit:SQRA.....	486
[SOURce<hw>]:BB:GNSS:SVID<ch>:GPS:SIMulated:ORBit:SQRA.....	486
[SOURce<hw>]:BB:GNSS:SVID<ch>:NAVic:SIMulated:ORBit:ECCentricity.....	486
[SOURce<hw>]:BB:GNSS:SVID<ch>:QZSS:SIMulated:ORBit:ECCentricity.....	486
[SOURce<hw>]:BB:GNSS:SVID<ch>:GALileo:SIMulated:ORBit:ECCentricity.....	486
[SOURce<hw>]:BB:GNSS:SVID<ch>:BEIDou:SIMulated:ORBit:ECCentricity.....	486
[SOURce<hw>]:BB:GNSS:SVID<ch>:GPS:SIMulated:ORBit:ECCentricity.....	486
[SOURce<hw>]:BB:GNSS:SVID<ch>:NAVic:SIMulated:ORBit:IZERo.....	486
[SOURce<hw>]:BB:GNSS:SVID<ch>:QZSS:SIMulated:ORBit:IZERo.....	486
[SOURce<hw>]:BB:GNSS:SVID<ch>:GALileo:SIMulated:ORBit:IZERo.....	486
[SOURce<hw>]:BB:GNSS:SVID<ch>:BEIDou:SIMulated:ORBit:IZERo.....	486
[SOURce<hw>]:BB:GNSS:SVID<ch>:GPS:SIMulated:ORBit:IZERo.....	486
[SOURce<hw>]:BB:GNSS:SVID<ch>:NAVic:SIMulated:ORBit:OZERo.....	486
[SOURce<hw>]:BB:GNSS:SVID<ch>:QZSS:SIMulated:ORBit:OZERo.....	486
[SOURce<hw>]:BB:GNSS:SVID<ch>:GALileo:SIMulated:ORBit:OZERo.....	486
[SOURce<hw>]:BB:GNSS:SVID<ch>:BEIDou:SIMulated:ORBit:OZERo.....	487
[SOURce<hw>]:BB:GNSS:SVID<ch>:GPS:SIMulated:ORBit:OZERo.....	487
[SOURce<hw>]:BB:GNSS:SVID<ch>:NAVic:SIMulated:ORBit:OMEGa.....	487
[SOURce<hw>]:BB:GNSS:SVID<ch>:QZSS:SIMulated:ORBit:OMEGa.....	487
[SOURce<hw>]:BB:GNSS:SVID<ch>:GALileo:SIMulated:ORBit:OMEGa.....	487
[SOURce<hw>]:BB:GNSS:SVID<ch>:BEIDou:SIMulated:ORBit:OMEGa.....	487
[SOURce<hw>]:BB:GNSS:SVID<ch>:GPS:SIMulated:ORBit:OMEGa.....	487
[SOURce<hw>]:BB:GNSS:SVID<ch>:NAVic:SIMulated:ORBit:MZERo.....	487
[SOURce<hw>]:BB:GNSS:SVID<ch>:QZSS:SIMulated:ORBit:MZERo.....	487
[SOURce<hw>]:BB:GNSS:SVID<ch>:GALileo:SIMulated:ORBit:MZERo.....	487
[SOURce<hw>]:BB:GNSS:SVID<ch>:BEIDou:SIMulated:ORBit:MZERo.....	487
[SOURce<hw>]:BB:GNSS:SVID<ch>:GPS:SIMulated:ORBit:MZERo.....	487
[SOURce<hw>]:BB:GNSS:SVID<ch>:NAVic:SIMulated:ORBit:IDOT.....	487
[SOURce<hw>]:BB:GNSS:SVID<ch>:QZSS:SIMulated:ORBit:IDOT.....	487
[SOURce<hw>]:BB:GNSS:SVID<ch>:GALileo:SIMulated:ORBit:IDOT.....	487
[SOURce<hw>]:BB:GNSS:SVID<ch>:BEIDou:SIMulated:ORBit:IDOT.....	487
[SOURce<hw>]:BB:GNSS:SVID<ch>:GPS:SIMulated:ORBit:IDOT.....	487
[SOURce<hw>]:BB:GNSS:SVID<ch>:NAVic:SIMulated:ORBit:ODOT.....	488
[SOURce<hw>]:BB:GNSS:SVID<ch>:QZSS:SIMulated:ORBit:ODOT.....	488
[SOURce<hw>]:BB:GNSS:SVID<ch>:GALileo:SIMulated:ORBit:ODOT.....	488
[SOURce<hw>]:BB:GNSS:SVID<ch>:BEIDou:SIMulated:ORBit:ODOT.....	488
[SOURce<hw>]:BB:GNSS:SVID<ch>:GPS:SIMulated:ORBit:ODOT.....	488
[SOURce<hw>]:BB:GNSS:SVID<ch>:NAVic:SIMulated:ORBit:NDELta.....	488
[SOURce<hw>]:BB:GNSS:SVID<ch>:QZSS:SIMulated:ORBit:NDELta.....	488
[SOURce<hw>]:BB:GNSS:SVID<ch>:GALileo:SIMulated:ORBit:NDELta.....	488
[SOURce<hw>]:BB:GNSS:SVID<ch>:BEIDou:SIMulated:ORBit:NDELta.....	488
[SOURce<hw>]:BB:GNSS:SVID<ch>:GPS:SIMulated:ORBit:NDELta.....	488
[SOURce<hw>]:BB:GNSS:SVID<ch>:NAVic:SIMulated:ORBit:CUC.....	488

Navigation message commands

[SOURce<hw>]:BB:GNSS:SVID<ch>:QZSS:SIMulated:ORBit:CUC.....	488
[SOURce<hw>]:BB:GNSS:SVID<ch>:GALileo:SIMulated:ORBit:CUC.....	488
[SOURce<hw>]:BB:GNSS:SVID<ch>:BEIDou:SIMulated:ORBit:CUC.....	488
[SOURce<hw>]:BB:GNSS:SVID<ch>:GPS:SIMulated:ORBit:CUC.....	488
[SOURce<hw>]:BB:GNSS:SVID<ch>:NAVic:SIMulated:ORBit:CUS.....	488
[SOURce<hw>]:BB:GNSS:SVID<ch>:QZSS:SIMulated:ORBit:CUS.....	488
[SOURce<hw>]:BB:GNSS:SVID<ch>:GALileo:SIMulated:ORBit:CUS.....	488
[SOURce<hw>]:BB:GNSS:SVID<ch>:BEIDou:SIMulated:ORBit:CUS.....	488
[SOURce<hw>]:BB:GNSS:SVID<ch>:GPS:SIMulated:ORBit:CUS.....	488
[SOURce<hw>]:BB:GNSS:SVID<ch>:NAVic:SIMulated:ORBit:CRc.....	489
[SOURce<hw>]:BB:GNSS:SVID<ch>:QZSS:SIMulated:ORBit:CRc.....	489
[SOURce<hw>]:BB:GNSS:SVID<ch>:GALileo:SIMulated:ORBit:CRc.....	489
[SOURce<hw>]:BB:GNSS:SVID<ch>:BEIDou:SIMulated:ORBit:CRc.....	489
[SOURce<hw>]:BB:GNSS:SVID<ch>:GPS:SIMulated:ORBit:CRc.....	489
[SOURce<hw>]:BB:GNSS:SVID<ch>:NAVic:SIMulated:ORBit:CRS.....	489
[SOURce<hw>]:BB:GNSS:SVID<ch>:QZSS:SIMulated:ORBit:CRS.....	489
[SOURce<hw>]:BB:GNSS:SVID<ch>:GALileo:SIMulated:ORBit:CRS.....	489
[SOURce<hw>]:BB:GNSS:SVID<ch>:BEIDou:SIMulated:ORBit:CRS.....	489
[SOURce<hw>]:BB:GNSS:SVID<ch>:GPS:SIMulated:ORBit:CRS.....	489
[SOURce<hw>]:BB:GNSS:SVID<ch>:NAVic:SIMulated:ORBit:CIC.....	489
[SOURce<hw>]:BB:GNSS:SVID<ch>:QZSS:SIMulated:ORBit:CIC.....	489
[SOURce<hw>]:BB:GNSS:SVID<ch>:GALileo:SIMulated:ORBit:CIC.....	489
[SOURce<hw>]:BB:GNSS:SVID<ch>:BEIDou:SIMulated:ORBit:CIC.....	489
[SOURce<hw>]:BB:GNSS:SVID<ch>:GPS:SIMulated:ORBit:CIC.....	489
[SOURce<hw>]:BB:GNSS:SVID<ch>:NAVic:SIMulated:ORBit:CIS.....	489
[SOURce<hw>]:BB:GNSS:SVID<ch>:QZSS:SIMulated:ORBit:CIS.....	489
[SOURce<hw>]:BB:GNSS:SVID<ch>:GALileo:SIMulated:ORBit:CIS.....	489
[SOURce<hw>]:BB:GNSS:SVID<ch>:BEIDou:SIMulated:ORBit:CIS.....	490
[SOURce<hw>]:BB:GNSS:SVID<ch>:GPS:SIMulated:ORBit:CIS.....	490
[SOURce<hw>]:BB:GNSS:SVID<ch>:NAVic:SIMulated:CLOCK:WNOC.....	490
[SOURce<hw>]:BB:GNSS:SVID<ch>:QZSS:SIMulated:CLOCK:WNOC.....	490
[SOURce<hw>]:BB:GNSS:SVID<ch>:GALileo:SIMulated:CLOCK:WNOC.....	490
[SOURce<hw>]:BB:GNSS:SVID<ch>:BEIDou:SIMulated:CLOCK:WNOC.....	490
[SOURce<hw>]:BB:GNSS:SVID<ch>:GPS:SIMulated:CLOCK:WNOC.....	490
[SOURce<hw>]:BB:GNSS:SVID<ch>:NAVic:SIMulated:CLOCK:TOC.....	490
[SOURce<hw>]:BB:GNSS:SVID<ch>:QZSS:SIMulated:CLOCK:TOC.....	490
[SOURce<hw>]:BB:GNSS:SVID<ch>:GALileo:SIMulated:CLOCK:TOC.....	490
[SOURce<hw>]:BB:GNSS:SVID<ch>:BEIDou:SIMulated:CLOCK:TOC.....	490
[SOURce<hw>]:BB:GNSS:SVID<ch>:GPS:SIMulated:CLOCK:TOC.....	490
[SOURce<hw>]:BB:GNSS:SVID<ch>:NAVic:SIMulated:CLOCK:AF<s2us0>.....	490
[SOURce<hw>]:BB:GNSS:SVID<ch>:SBAS:SIMulated:CLOCK:AF<s2us0>.....	490
[SOURce<hw>]:BB:GNSS:SVID<ch>:QZSS:SIMulated:CLOCK:AF<s2us0>.....	490
[SOURce<hw>]:BB:GNSS:SVID<ch>:GALileo:SIMulated:CLOCK:AF<s2us0>.....	490
[SOURce<hw>]:BB:GNSS:SVID<ch>:GLONass:SIMulated:CLOCK:AF<s2us0>.....	490
[SOURce<hw>]:BB:GNSS:SVID<ch>:BEIDou:SIMulated:CLOCK:AF<s2us0>.....	490
[SOURce<hw>]:BB:GNSS:SVID<ch>:GPS:SIMulated:CLOCK:AF<s2us0>.....	490
[SOURce<hw>]:BB:GNSS:SVID<ch>:NAVic:SIMulated:CLOCK:TGD.....	491
[SOURce<hw>]:BB:GNSS:SVID<ch>:QZSS:SIMulated:CLOCK:TGD.....	491
[SOURce<hw>]:BB:GNSS:SVID<ch>:GALileo:SIMulated:CLOCK:TGD.....	491

<code>[:SOURce<hw>]:BB:GNSS:SVID<ch>:GLONass:SIMulated:CLOCK:TGD</code>	491
<code>[:SOURce<hw>]:BB:GNSS:SVID<ch>:BEIDou:SIMulated:CLOCK:TGD<s2us></code>	491
<code>[:SOURce<hw>]:BB:GNSS:SVID<ch>:GPS:SIMulated:CLOCK:TGD</code>	491

`[:SOURce<hw>]:BB:GNSS:SSValues <ShowScaledValue>`

Defines if the navigation message parameters are set as scaled or unscaled values and thus which subset of remote-control commands is used.

Parameters:

`<ShowScaledValue>` 1 | ON | 0 | OFF

0

Used are unscaled values

The `SOURce<hw>:BB:GNSS: . . . :UNSCaled` commands apply.

1

Used are scaled values

Commands without the mnemonic `UNSCaled` apply.

*RST: 0

Example:

```
SOURce1:BB:GNSS:SSValues 0
SOURce1:BB:GNSS:SVID1:GPS:NMESSage:LNAV:EPHemeris:TOE:UNSCaled
// 28800
SOURce1:BB:GNSS:SSValues 1
SOURce1:BB:GNSS:SVID1:GPS:NMESSage:LNAV:EPHemeris:TOE?
// 1800
```

Manual operation: See "[Show Scaled Values](#)" on page 212

```
[:SOURce<hw>]:BB:GNSS:SVID<ch>:SBAS:SIMulated:ORBit:ZN <Zn>
[:SOURce<hw>]:BB:GNSS:SVID<ch>:SBAS:SIMulated:ORBit:YN <Yn>
[:SOURce<hw>]:BB:GNSS:SVID<ch>:SBAS:SIMulated:ORBit:ZN <Zn>
[:SOURce<hw>]:BB:GNSS:SVID<ch>:GLONass:SIMulated:ORBit:ZN <Zn>
[:SOURce<hw>]:BB:GNSS:SVID<ch>:GLONass:SIMulated:ORBit:YN <Yn>
[:SOURce<hw>]:BB:GNSS:SVID<ch>:GLONass:SIMulated:ORBit:ZN <Zn>
```

Set the X_n , Y_n and Z_n coordinates in PZ-90.

Parameters:

`<Zn>` float
 Increment: 1E-15
 *RST: 0

```
[:SOURce<hw>]:BB:GNSS:SVID<ch>:SBAS:SIMulated:ORBit:XDn <XnDot>
[:SOURce<hw>]:BB:GNSS:SVID<ch>:SBAS:SIMulated:ORBit:YDn <YnDot>
[:SOURce<hw>]:BB:GNSS:SVID<ch>:SBAS:SIMulated:ORBit:ZDn <ZnDot>
[:SOURce<hw>]:BB:GNSS:SVID<ch>:GLONass:SIMulated:ORBit:XDn <XnDot>
```

```
[:SOURce<hw>]:BB:GNSS:SVID<ch>:GLONass:SIMulated:ORBit:YDN <YnDot>
[:SOURce<hw>]:BB:GNSS:SVID<ch>:GLONass:SIMulated:ORBit:ZDN <ZnDot>
```

Sets the velocity components X'_n , Y'_n and Z'_n .

Parameters:

```
<ZnDot>          float
                  Increment: 1E-15
                  *RST:      0
```

```
[:SOURce<hw>]:BB:GNSS:SVID<ch>:SBAS:SIMulated:ORBit:XDDN <XnDotDot>
[:SOURce<hw>]:BB:GNSS:SVID<ch>:SBAS:SIMulated:ORBit:YDDN <YnDotDot>
[:SOURce<hw>]:BB:GNSS:SVID<ch>:SBAS:SIMulated:ORBit:ZDDN <ZnDotDot>
[:SOURce<hw>]:BB:GNSS:SVID<ch>:GLONass:SIMulated:ORBit:XDDN
<XnDotDot>
[:SOURce<hw>]:BB:GNSS:SVID<ch>:GLONass:SIMulated:ORBit:YDDN
<YnDotDot>
[:SOURce<hw>]:BB:GNSS:SVID<ch>:GLONass:SIMulated:ORBit:ZDDN
<ZnDotDot>
```

Sets the moon and sun acceleration parameters X''_n , Y''_n and Z''_n .

Parameters:

```
<ZnDotDot>       float
                  Increment: 1E-15
                  *RST:      0
```

```
[:SOURce<hw>]:BB:GNSS:SVID<ch>:NAVic:SIMulated:ORBit:WNOE <SimToe>
[:SOURce<hw>]:BB:GNSS:SVID<ch>:QZSS:SIMulated:ORBit:WNOE <SimToe>
[:SOURce<hw>]:BB:GNSS:SVID<ch>:GALileo:SIMulated:ORBit:WNOE <SimToe>
[:SOURce<hw>]:BB:GNSS:SVID<ch>:BEIDou:SIMulated:ORBit:WNOE <SimToe>
[:SOURce<hw>]:BB:GNSS:SVID<ch>:GPS:SIMulated:ORBit:WNOE <SimToe>
```

Sets the reference week.

Parameters:

```
<SimToe>         integer
                  Range:      0 to 10000
                  *RST:      0
```

```
[:SOURce<hw>]:BB:GNSS:SVID<ch>:NAVic:SIMulated:ORBit:TOE <SimToe>
[:SOURce<hw>]:BB:GNSS:SVID<ch>:QZSS:SIMulated:ORBit:TOE <SimToe>
[:SOURce<hw>]:BB:GNSS:SVID<ch>:GALileo:SIMulated:ORBit:TOE <SimToe>
[:SOURce<hw>]:BB:GNSS:SVID<ch>:BEIDou:SIMulated:ORBit:TOE <SimToe>
[:SOURce<hw>]:BB:GNSS:SVID<ch>:GPS:SIMulated:ORBit:TOE <SimToe>
```

Sets the reference time of week.

Parameters:

<SimToe> float
 Increment: 1E-15
 *RST: 0

[:SOURCE<hw>]:BB:GNSS:SVID<ch>:SBAS:SIMulated:ORBit:DATE <Year>, <Month>, <Day>

[:SOURCE<hw>]:BB:GNSS:SVID<ch>:SBAS:SIMulated:CLOCK:DATE <Year>, <Month>, <Day>

[:SOURCE<hw>]:BB:GNSS:SVID<ch>:GLONass:SIMulated:ORBit:DATE <Year>, <Month>, <Day>

[:SOURCE<hw>]:BB:GNSS:SVID<ch>:GLONass:SIMulated:CLOCK:DATE <Year>, <Month>, <Day>

Sets the reference date.

Parameters:

<Year> integer
 Range: 1996 to 9999

<Month> integer
 Range: 1 to 12

<Day> integer
 Range: 1 to 31

[:SOURCE<hw>]:BB:GNSS:SVID<ch>:SBAS:SIMulated:ORBit:TIME <Hour>, <Minute>, <Second>

[:SOURCE<hw>]:BB:GNSS:SVID<ch>:SBAS:SIMulated:CLOCK:TIME <Hour>, <Minute>, <Second>

[:SOURCE<hw>]:BB:GNSS:SVID<ch>:GLONass:SIMulated:ORBit:TIME <Hour>, <Minute>, <Second>

[:SOURCE<hw>]:BB:GNSS:SVID<ch>:GLONass:SIMulated:CLOCK:TIME <Hour>, <Minute>, <Second>

Sets the reference time.

Parameters:

<Hour> integer
 Range: 0 to 23

<Minute> integer
 Range: 0 to 59

<Second> float
 Range: 0 to 59.999
 Increment: 0.001

[:SOURCE<hw>]:BB:GNSS:SVID<ch>:NAVic:SIMulated:ORBit:SQRA <SqrtA>

[:SOURCE<hw>]:BB:GNSS:SVID<ch>:QZSS:SIMulated:ORBit:SQRA <SqrtA>

```
[:SOURce<hw>]:BB:GNSS:SVID<ch>:GALileo:SIMulated:ORBit:SQRA <SqrtA>
[:SOURce<hw>]:BB:GNSS:SVID<ch>:BEIDou:SIMulated:ORBit:SQRA <SqrtA>
[:SOURce<hw>]:BB:GNSS:SVID<ch>:GPS:SIMulated:ORBit:SQRA <SqrtA>
```

Sets the square root of semi-major axis.

Parameters:

```
<SqrtA>          integer
                  Range:    0.190735 to 8192
                  Increment: 1E-6
                  *RST:     0.190735
```

```
[:SOURce<hw>]:BB:GNSS:SVID<ch>:NAVic:SIMulated:ORBit:ECCentricity
<Eccentricity>
[:SOURce<hw>]:BB:GNSS:SVID<ch>:QZSS:SIMulated:ORBit:ECCentricity
<Eccentricity>
[:SOURce<hw>]:BB:GNSS:SVID<ch>:GALileo:SIMulated:ORBit:ECCentricity
<Eccentricity>
[:SOURce<hw>]:BB:GNSS:SVID<ch>:BEIDou:SIMulated:ORBit:ECCentricity
<Eccentricity>
[:SOURce<hw>]:BB:GNSS:SVID<ch>:GPS:SIMulated:ORBit:ECCentricity
<Eccentricity>
```

Sets the eccentricity.

Parameters:

```
<Eccentricity>  integer
                  Range:    0 to 4294967295
                  *RST:     0
```

```
[:SOURce<hw>]:BB:GNSS:SVID<ch>:NAVic:SIMulated:ORBit:IZERo <I0>
[:SOURce<hw>]:BB:GNSS:SVID<ch>:QZSS:SIMulated:ORBit:IZERo <I0>
[:SOURce<hw>]:BB:GNSS:SVID<ch>:GALileo:SIMulated:ORBit:IZERo <I0>
[:SOURce<hw>]:BB:GNSS:SVID<ch>:BEIDou:SIMulated:ORBit:IZERo <I0>
[:SOURce<hw>]:BB:GNSS:SVID<ch>:GPS:SIMulated:ORBit:IZERo <I0>
```

Sets inclination angle.

Parameters:

```
<I0>            float
                  Increment: 1E-15
                  *RST:     0
```

```
[:SOURce<hw>]:BB:GNSS:SVID<ch>:NAVic:SIMulated:ORBit:OZERo <Omega0>
[:SOURce<hw>]:BB:GNSS:SVID<ch>:QZSS:SIMulated:ORBit:OZERo <Omega0>
[:SOURce<hw>]:BB:GNSS:SVID<ch>:GALileo:SIMulated:ORBit:OZERo
<Omega0>
```

[:SOURce<hw>]:BB:GNSS:SVID<ch>:BEIDou:SIMulated:ORBit:OZERo
 <Omega0>

[:SOURce<hw>]:BB:GNSS:SVID<ch>:GPS:SIMulated:ORBit:OZERo <Omega0>

Sets the longitude of ascending node.

Parameters:

<Omega0> float
 Increment: 1E-15
 *RST: 0

[:SOURce<hw>]:BB:GNSS:SVID<ch>:NAVic:SIMulated:ORBit:OMEGa <Omega>

[:SOURce<hw>]:BB:GNSS:SVID<ch>:QZSS:SIMulated:ORBit:OMEGa <Omega>

[:SOURce<hw>]:BB:GNSS:SVID<ch>:GALileo:SIMulated:ORBit:OMEGa
 <Omega>

[:SOURce<hw>]:BB:GNSS:SVID<ch>:BEIDou:SIMulated:ORBit:OMEGa <Omega>

[:SOURce<hw>]:BB:GNSS:SVID<ch>:GPS:SIMulated:ORBit:OMEGa <Omega>

Sets the argument of perigee.

Parameters:

<Omega> float
 Increment: 1E-15
 *RST: 0

[:SOURce<hw>]:BB:GNSS:SVID<ch>:NAVic:SIMulated:ORBit:MZERo <M0>

[:SOURce<hw>]:BB:GNSS:SVID<ch>:QZSS:SIMulated:ORBit:MZERo <M0>

[:SOURce<hw>]:BB:GNSS:SVID<ch>:GALileo:SIMulated:ORBit:MZERo <M0>

[:SOURce<hw>]:BB:GNSS:SVID<ch>:BEIDou:SIMulated:ORBit:MZERo <M0>

[:SOURce<hw>]:BB:GNSS:SVID<ch>:GPS:SIMulated:ORBit:MZERo <M0>

Sets the mean anomaly.

Parameters:

<M0> float
 Increment: 1E-15
 *RST: 0

[:SOURce<hw>]:BB:GNSS:SVID<ch>:NAVic:SIMulated:ORBit:IDOT <Idot>

[:SOURce<hw>]:BB:GNSS:SVID<ch>:QZSS:SIMulated:ORBit:IDOT <Idot>

[:SOURce<hw>]:BB:GNSS:SVID<ch>:GALileo:SIMulated:ORBit:IDOT <Idot>

[:SOURce<hw>]:BB:GNSS:SVID<ch>:BEIDou:SIMulated:ORBit:IDOT <Idot>

[:SOURce<hw>]:BB:GNSS:SVID<ch>:GPS:SIMulated:ORBit:IDOT <Idot>

Sets the rate of inclination angle.

Parameters:

<Idot> float
 Increment: 1E-15
 *RST: 0

```
[:SOURce<hw>]:BB:GNSS:SVID<ch>:NAVic:SIMulated:ORBit:ODOT <OmegaDot>
[:SOURce<hw>]:BB:GNSS:SVID<ch>:QZSS:SIMulated:ORBit:ODOT <OmegaDot>
[:SOURce<hw>]:BB:GNSS:SVID<ch>:GALileo:SIMulated:ORBit:ODOT
  <OmegaDot>
[:SOURce<hw>]:BB:GNSS:SVID<ch>:BEIDou:SIMulated:ORBit:ODOT
  <OmegaDot>
[:SOURce<hw>]:BB:GNSS:SVID<ch>:GPS:SIMulated:ORBit:ODOT <OmegaDot>
```

Sets the rate of right ascension.

Parameters:

```
<OmegaDot>          float
                    Increment: 1E-15
                    *RST:      0
```

```
[:SOURce<hw>]:BB:GNSS:SVID<ch>:NAVic:SIMulated:ORBit:NDELta <DeltaN>
[:SOURce<hw>]:BB:GNSS:SVID<ch>:QZSS:SIMulated:ORBit:NDELta <DeltaN>
[:SOURce<hw>]:BB:GNSS:SVID<ch>:GALileo:SIMulated:ORBit:NDELta <DeltaN>
[:SOURce<hw>]:BB:GNSS:SVID<ch>:BEIDou:SIMulated:ORBit:NDELta <DeltaN>
[:SOURce<hw>]:BB:GNSS:SVID<ch>:GPS:SIMulated:ORBit:NDELta <DeltaN>
```

Sets the mean motion difference.

Parameters:

```
<DeltaN>           float
                    Increment: 1E-15
                    *RST:      0
```

```
[:SOURce<hw>]:BB:GNSS:SVID<ch>:NAVic:SIMulated:ORBit:CUC <Cuc>
[:SOURce<hw>]:BB:GNSS:SVID<ch>:QZSS:SIMulated:ORBit:CUC <Cuc>
[:SOURce<hw>]:BB:GNSS:SVID<ch>:GALileo:SIMulated:ORBit:CUC <Cuc>
[:SOURce<hw>]:BB:GNSS:SVID<ch>:BEIDou:SIMulated:ORBit:CUC <Cuc>
[:SOURce<hw>]:BB:GNSS:SVID<ch>:GPS:SIMulated:ORBit:CUC <Cuc>
```

Sets the cosine difference of latitude.

Parameters:

```
<Cuc>              float
                    Increment: 1E-15
                    *RST:      0
```

```
[:SOURce<hw>]:BB:GNSS:SVID<ch>:NAVic:SIMulated:ORBit:CUS <Cus>
[:SOURce<hw>]:BB:GNSS:SVID<ch>:QZSS:SIMulated:ORBit:CUS <Cus>
[:SOURce<hw>]:BB:GNSS:SVID<ch>:GALileo:SIMulated:ORBit:CUS <Cus>
[:SOURce<hw>]:BB:GNSS:SVID<ch>:BEIDou:SIMulated:ORBit:CUS <Cus>
[:SOURce<hw>]:BB:GNSS:SVID<ch>:GPS:SIMulated:ORBit:CUS <Cus>
```

Sets the sine difference of latitude.

Parameters:

<Cus> float
 Increment: 1E-15
 *RST: 0

```
[:SOURce<hw>]:BB:GNSS:SVID<ch>:NAVic:SIMulated:ORBit:CRC <Crc>
[:SOURce<hw>]:BB:GNSS:SVID<ch>:QZSS:SIMulated:ORBit:CRC <Crc>
[:SOURce<hw>]:BB:GNSS:SVID<ch>:GALileo:SIMulated:ORBit:CRC <Crc>
[:SOURce<hw>]:BB:GNSS:SVID<ch>:BEIDou:SIMulated:ORBit:CRC <Crc>
[:SOURce<hw>]:BB:GNSS:SVID<ch>:GPS:SIMulated:ORBit:CRC <Crc>
```

Sets the cosine difference of orbital radius.

Parameters:

<Crc> float
 Increment: 1E-15
 *RST: 0

```
[:SOURce<hw>]:BB:GNSS:SVID<ch>:NAVic:SIMulated:ORBit:CRS <Crs>
[:SOURce<hw>]:BB:GNSS:SVID<ch>:QZSS:SIMulated:ORBit:CRS <Crs>
[:SOURce<hw>]:BB:GNSS:SVID<ch>:GALileo:SIMulated:ORBit:CRS <Crs>
[:SOURce<hw>]:BB:GNSS:SVID<ch>:BEIDou:SIMulated:ORBit:CRS <Crs>
[:SOURce<hw>]:BB:GNSS:SVID<ch>:GPS:SIMulated:ORBit:CRS <Crs>
```

Sets the sine difference of orbital radius.

Parameters:

<Crs> float
 Increment: 1E-15
 *RST: 0

```
[:SOURce<hw>]:BB:GNSS:SVID<ch>:NAVic:SIMulated:ORBit:CIC <Cic>
[:SOURce<hw>]:BB:GNSS:SVID<ch>:QZSS:SIMulated:ORBit:CIC <Cic>
[:SOURce<hw>]:BB:GNSS:SVID<ch>:GALileo:SIMulated:ORBit:CIC <Cic>
[:SOURce<hw>]:BB:GNSS:SVID<ch>:BEIDou:SIMulated:ORBit:CIC <Cic>
[:SOURce<hw>]:BB:GNSS:SVID<ch>:GPS:SIMulated:ORBit:CIC <Cic>
```

Sets the cosine difference of inclination.

Parameters:

<Cic> float
 Increment: 1E-15
 *RST: 0

```
[:SOURce<hw>]:BB:GNSS:SVID<ch>:NAVic:SIMulated:ORBit:CIS <Cis>
[:SOURce<hw>]:BB:GNSS:SVID<ch>:QZSS:SIMulated:ORBit:CIS <Cis>
[:SOURce<hw>]:BB:GNSS:SVID<ch>:GALileo:SIMulated:ORBit:CIS <Cis>
```

```
[ :SOURce<hw>]:BB:GNSS:SVID<ch>:BEIDou:SIMulated:ORBit:CIS <Cis>
[:SOURce<hw>]:BB:GNSS:SVID<ch>:GPS:SIMulated:ORBit:CIS <Cis>
```

Sets the sine difference of inclination.

Parameters:

```
<Cis>                float
                    Increment: 1E-15
                    *RST:      0
```

```
[ :SOURce<hw>]:BB:GNSS:SVID<ch>:NAVic:SIMulated:CLOCK:WNOc <Toc>
[:SOURce<hw>]:BB:GNSS:SVID<ch>:QZSS:SIMulated:CLOCK:WNOc <Toc>
[:SOURce<hw>]:BB:GNSS:SVID<ch>:GALileo:SIMulated:CLOCK:WNOc <Toc>
[:SOURce<hw>]:BB:GNSS:SVID<ch>:BEIDou:SIMulated:CLOCK:WNOc <Toc>
[:SOURce<hw>]:BB:GNSS:SVID<ch>:GPS:SIMulated:CLOCK:WNOc <Toc>
```

Sets the reference week.

Parameters:

```
<Toc>                integer
                    Range:      0 to 10000
                    *RST:      0
```

```
[ :SOURce<hw>]:BB:GNSS:SVID<ch>:NAVic:SIMulated:CLOCK:TOC <Toc>
[:SOURce<hw>]:BB:GNSS:SVID<ch>:QZSS:SIMulated:CLOCK:TOC <Toc>
[:SOURce<hw>]:BB:GNSS:SVID<ch>:GALileo:SIMulated:CLOCK:TOC <Toc>
[:SOURce<hw>]:BB:GNSS:SVID<ch>:BEIDou:SIMulated:CLOCK:TOC <Toc>
[:SOURce<hw>]:BB:GNSS:SVID<ch>:GPS:SIMulated:CLOCK:TOC <Toc>
```

Sets the reference time of week.

Parameters:

```
<Toc>                float
                    Increment: 1E-15
                    *RST:      0
```

```
[ :SOURce<hw>]:BB:GNSS:SVID<ch>:NAVic:SIMulated:CLOCK:AF<s2us0> <Af>
[:SOURce<hw>]:BB:GNSS:SVID<ch>:SBAS:SIMulated:CLOCK:AF<s2us0> <Af>
[:SOURce<hw>]:BB:GNSS:SVID<ch>:QZSS:SIMulated:CLOCK:AF<s2us0> <Af>
[:SOURce<hw>]:BB:GNSS:SVID<ch>:GALileo:SIMulated:CLOCK:AF<s2us0> <Af>
[:SOURce<hw>]:BB:GNSS:SVID<ch>:GLONass:SIMulated:CLOCK:AF<s2us0>
<Af>
[:SOURce<hw>]:BB:GNSS:SVID<ch>:BEIDou:SIMulated:CLOCK:AF<s2us0> <Af>
[:SOURce<hw>]:BB:GNSS:SVID<ch>:GPS:SIMulated:CLOCK:AF<s2us0> <Af>
```

Sets the values of a_{f0} , a_{f1} or $-a_{f2}$.

Parameters:

```
<Af>                integer
                    *RST:      0
```

```

[:SOURce<hw>]:BB:GNSS:SVID<ch>:NAVic:SIMulated:CLOCK:TGD <Tgd>
[:SOURce<hw>]:BB:GNSS:SVID<ch>:QZSS:SIMulated:CLOCK:TGD <Tgd>
[:SOURce<hw>]:BB:GNSS:SVID<ch>:GALileo:SIMulated:CLOCK:TGD <Tgd>
[:SOURce<hw>]:BB:GNSS:SVID<ch>:GLONass:SIMulated:CLOCK:TGD <Tgd>
[:SOURce<hw>]:BB:GNSS:SVID<ch>:BEIDou:SIMulated:CLOCK:TGD<s2us>
  <Tgd>
[:SOURce<hw>]:BB:GNSS:SVID<ch>:GPS:SIMulated:CLOCK:TGD <Tgd>

```

Sets the group delay.

Parameters:

```

<Tgd>                float
                    Increment: 1E-15
                    *RST:      0

```

22.13.2 Pseudorange commands

[:SOURce<hw>]:BB:GNSS:SVID<ch>:NAVic:PRERrors:MODE.....	493
[:SOURce<hw>]:BB:GNSS:SVID<ch>:QZSS:PRERrors:MODE.....	493
[:SOURce<hw>]:BB:GNSS:SVID<ch>:GALileo:PRERrors:MODE.....	493
[:SOURce<hw>]:BB:GNSS:SVID<ch>:GLONass:PRERrors:MODE.....	493
[:SOURce<hw>]:BB:GNSS:SVID<ch>:SBAS:PRERrors:MODE.....	493
[:SOURce<hw>]:BB:GNSS:SVID<ch>:BEIDou:PRERrors:MODE.....	493
[:SOURce<hw>]:BB:GNSS:SVID<ch>:GPS:PRERrors:MODE.....	493
[:SOURce<hw>]:BB:GNSS:PERRors:CATalog.....	493
[:SOURce<hw>]:BB:GNSS:SVID<ch>:NAVic:PRERrors:FILE.....	494
[:SOURce<hw>]:BB:GNSS:SVID<ch>:QZSS:PRERrors:FILE.....	494
[:SOURce<hw>]:BB:GNSS:SVID<ch>:GALileo:PRERrors:FILE.....	494
[:SOURce<hw>]:BB:GNSS:SVID<ch>:GLONass:PRERrors:FILE.....	494
[:SOURce<hw>]:BB:GNSS:SVID<ch>:SBAS:PRERrors:FILE.....	494
[:SOURce<hw>]:BB:GNSS:SVID<ch>:BEIDou:PRERrors:FILE.....	494
[:SOURce<hw>]:BB:GNSS:SVID<ch>:GPS:PRERrors:FILE.....	494
[:SOURce<hw>]:BB:GNSS:SVID<ch>:NAVic:PRERrors:COPY:SVID.....	494
[:SOURce<hw>]:BB:GNSS:SVID<ch>:QZSS:PRERrors:COPY:SVID.....	494
[:SOURce<hw>]:BB:GNSS:SVID<ch>:GALileo:PRERrors:COPY:SVID.....	494
[:SOURce<hw>]:BB:GNSS:SVID<ch>:GLONass:PRERrors:COPY:SVID.....	494
[:SOURce<hw>]:BB:GNSS:SVID<ch>:SBAS:PRERrors:COPY:SVID.....	494
[:SOURce<hw>]:BB:GNSS:SVID<ch>:BEIDou:PRERrors:COPY:SVID.....	494
[:SOURce<hw>]:BB:GNSS:SVID<ch>:GPS:PRERrors:COPY:SVID.....	494
[:SOURce<hw>]:BB:GNSS:SVID<ch>:NAVic:PRERrors:COPY:EXECute.....	495
[:SOURce<hw>]:BB:GNSS:SVID<ch>:QZSS:PRERrors:COPY:EXECute.....	495
[:SOURce<hw>]:BB:GNSS:SVID<ch>:GALileo:PRERrors:COPY:EXECute.....	495
[:SOURce<hw>]:BB:GNSS:SVID<ch>:GLONass:PRERrors:COPY:EXECute.....	495
[:SOURce<hw>]:BB:GNSS:SVID<ch>:SBAS:PRERrors:COPY:EXECute.....	495
[:SOURce<hw>]:BB:GNSS:SVID<ch>:BEIDou:PRERrors:COPY:EXECute.....	495
[:SOURce<hw>]:BB:GNSS:SVID<ch>:GPS:PRERrors:COPY:EXECute.....	495
[:SOURce<hw>]:BB:GNSS:SVID<ch>:NAVic:PRERrors:VALue.....	495
[:SOURce<hw>]:BB:GNSS:SVID<ch>:QZSS:PRERrors:VALue.....	495
[:SOURce<hw>]:BB:GNSS:SVID<ch>:GALileo:PRERrors:VALue.....	495

Navigation message commands

[SOURce<hw>]:BB:GNSS:SVID<ch>:GLONass:PRERrors:VALue.....	495
[SOURce<hw>]:BB:GNSS:SVID<ch>:SBAS:PRERrors:VALue.....	496
[SOURce<hw>]:BB:GNSS:SVID<ch>:BEIDou:PRERrors:VALue.....	496
[SOURce<hw>]:BB:GNSS:SVID<ch>:GPS:PRERrors:VALue.....	496
[SOURce<hw>]:BB:GNSS:SVID<ch>:NAVic:PRERrors:PROFile:OFFSet.....	496
[SOURce<hw>]:BB:GNSS:SVID<ch>:QZSS:PRERrors:PROFile:OFFSet.....	496
[SOURce<hw>]:BB:GNSS:SVID<ch>:GALileo:PRERrors:PROFile:OFFSet.....	496
[SOURce<hw>]:BB:GNSS:SVID<ch>:GLONass:PRERrors:PROFile:OFFSet.....	496
[SOURce<hw>]:BB:GNSS:SVID<ch>:SBAS:PRERrors:PROFile:OFFSet.....	496
[SOURce<hw>]:BB:GNSS:SVID<ch>:BEIDou:PRERrors:PROFile:OFFSet.....	496
[SOURce<hw>]:BB:GNSS:SVID<ch>:GPS:PRERrors:PROFile:OFFSet.....	496
[SOURce<hw>]:BB:GNSS:SVID<ch>:NAVic:PRERrors:PROFile:COUNT?.....	496
[SOURce<hw>]:BB:GNSS:SVID<ch>:QZSS:PRERrors:PROFile:COUNT?.....	496
[SOURce<hw>]:BB:GNSS:SVID<ch>:GALileo:PRERrors:PROFile:COUNT?.....	496
[SOURce<hw>]:BB:GNSS:SVID<ch>:GLONass:PRERrors:PROFile:COUNT?.....	496
[SOURce<hw>]:BB:GNSS:SVID<ch>:SBAS:PRERrors:PROFile:COUNT?.....	496
[SOURce<hw>]:BB:GNSS:SVID<ch>:BEIDou:PRERrors:PROFile:COUNT?.....	497
[SOURce<hw>]:BB:GNSS:SVID<ch>:GPS:PRERrors:PROFile:COUNT?.....	497
[SOURce<hw>]:BB:GNSS:SVID<ch>:NAVic:PRERrors:PROFile:APPend.....	497
[SOURce<hw>]:BB:GNSS:SVID<ch>:QZSS:PRERrors:PROFile:APPend.....	497
[SOURce<hw>]:BB:GNSS:SVID<ch>:GALileo:PRERrors:PROFile:APPend.....	497
[SOURce<hw>]:BB:GNSS:SVID<ch>:GLONass:PRERrors:PROFile:APPend.....	497
[SOURce<hw>]:BB:GNSS:SVID<ch>:SBAS:PRERrors:PROFile:APPend.....	497
[SOURce<hw>]:BB:GNSS:SVID<ch>:BEIDou:PRERrors:PROFile:APPend.....	497
[SOURce<hw>]:BB:GNSS:SVID<ch>:GPS:PRERrors:PROFile:APPend.....	497
[SOURce<hw>]:BB:GNSS:SVID<ch>:NAVic:PRERrors:PROFile<gr>:REFerence.....	497
[SOURce<hw>]:BB:GNSS:SVID<ch>:QZSS:PRERrors:PROFile<gr>:REFerence.....	497
[SOURce<hw>]:BB:GNSS:SVID<ch>:GALileo:PRERrors:PROFile<gr>:REFerence.....	497
[SOURce<hw>]:BB:GNSS:SVID<ch>:GLONass:PRERrors:PROFile<gr>:REFerence.....	497
[SOURce<hw>]:BB:GNSS:SVID<ch>:SBAS:PRERrors:PROFile<gr>:REFerence.....	497
[SOURce<hw>]:BB:GNSS:SVID<ch>:BEIDou:PRERrors:PROFile<gr>:REFerence.....	497
[SOURce<hw>]:BB:GNSS:SVID<ch>:GLONass:PRERrors:PROFile<gr>:REFerence.....	497
[SOURce<hw>]:BB:GNSS:SVID<ch>:SBAS:PRERrors:PROFile<gr>:REFerence.....	498
[SOURce<hw>]:BB:GNSS:SVID<ch>:GPS:PRERrors:PROFile<gr>:REFerence.....	498
[SOURce<hw>]:BB:GNSS:SVID<ch>:NAVic:PRERrors:PROFile<gr>:VALue.....	498
[SOURce<hw>]:BB:GNSS:SVID<ch>:QZSS:PRERrors:PROFile<gr>:VALue.....	498
[SOURce<hw>]:BB:GNSS:SVID<ch>:GALileo:PRERrors:PROFile<gr>:VALue.....	498
[SOURce<hw>]:BB:GNSS:SVID<ch>:GLONass:PRERrors:PROFile<gr>:VALue.....	498
[SOURce<hw>]:BB:GNSS:SVID<ch>:SBAS:PRERrors:PROFile<gr>:VALue.....	498
[SOURce<hw>]:BB:GNSS:SVID<ch>:BEIDou:PRERrors:PROFile<gr>:VALue.....	498
[SOURce<hw>]:BB:GNSS:SVID<ch>:GPS:PRERrors:PROFile<gr>:VALue.....	498
[SOURce<hw>]:BB:GNSS:SVID<ch>:NAVic:PRERrors:PROFile<gr>:INSert.....	499
[SOURce<hw>]:BB:GNSS:SVID<ch>:QZSS:PRERrors:PROFile<gr>:INSert.....	499
[SOURce<hw>]:BB:GNSS:SVID<ch>:GALileo:PRERrors:PROFile<gr>:INSert.....	499
[SOURce<hw>]:BB:GNSS:SVID<ch>:GLONass:PRERrors:PROFile<gr>:INSert.....	499
[SOURce<hw>]:BB:GNSS:SVID<ch>:SBAS:PRERrors:PROFile<gr>:INSert.....	499
[SOURce<hw>]:BB:GNSS:SVID<ch>:BEIDou:PRERrors:PROFile<gr>:INSert.....	499
[SOURce<hw>]:BB:GNSS:SVID<ch>:GPS:PRERrors:PROFile<gr>:INSert.....	499
[SOURce<hw>]:BB:GNSS:SVID<ch>:NAVic:PRERrors:PROFile<gr>:DELete.....	499
[SOURce<hw>]:BB:GNSS:SVID<ch>:QZSS:PRERrors:PROFile<gr>:DELete.....	499

<code>[:SOURCE<hw>]:BB:GNSS:SVID<ch>:GALileo:PRERrors:PROFile<gr>:DELeTe</code>	499
<code>[:SOURCE<hw>]:BB:GNSS:SVID<ch>:GLONass:PRERrors:PROFile<gr>:DELeTe</code>	499
<code>[:SOURCE<hw>]:BB:GNSS:SVID<ch>:SBAS:PRERrors:PROFile<gr>:DELeTe</code>	499
<code>[:SOURCE<hw>]:BB:GNSS:SVID<ch>:BEIDou:PRERrors:PROFile<gr>:DELeTe</code>	499
<code>[:SOURCE<hw>]:BB:GNSS:SVID<ch>:GPS:PRERrors:PROFile<gr>:DELeTe</code>	499

[:SOURCE<hw>]:BB:GNSS:SVID<ch>:NAVic:PRERrors:MODE <PRErrorsMode>
[:SOURCE<hw>]:BB:GNSS:SVID<ch>:QZSS:PRERrors:MODE <PRErrorsMode>
[:SOURCE<hw>]:BB:GNSS:SVID<ch>:GALileo:PRERrors:MODE <PRErrorsMode>
[:SOURCE<hw>]:BB:GNSS:SVID<ch>:GLONass:PRERrors:MODE
 <PRErrorsMode>
[:SOURCE<hw>]:BB:GNSS:SVID<ch>:SBAS:PRERrors:MODE <PRErrorsMode>
[:SOURCE<hw>]:BB:GNSS:SVID<ch>:BEIDou:PRERrors:MODE <PRErrorsMode>
[:SOURCE<hw>]:BB:GNSS:SVID<ch>:GPS:PRERrors:MODE <PRErrorsMode>

Sets how the pseudorange errors are defined.

Parameters:

<PRErrorsMode> FSBas | CONStant | PROFile | FILE

FSBas

Extracted from the imported SBAS corrections.

CONStant

Set with the command `[:SOURCE<hw>]:BB:GNSS:SVID<ch>:GPS:PRERrors:VALue`

PROFile

Defined with the command pairs `[:SOURCE<hw>]:BB:GNSS:SVID<ch>:GPS:PRERrors:PROFile<gr>:REFeRence` and `[:SOURCE<hw>]:BB:GNSS:SVID<ch>:GPS:PRERrors:PROFile<gr>:VALue`

FILE

Sets pseudorange errors according to a file with extension `*.rs_perr`. Select the file via `[:SOURCE<hw>]:BB:GNSS:SVID<ch>:GPS:PRERrors:FILE`.

*RST: CONStant

Example: See [Example"Configuring a pseudorange error ramp"](#) on page 478.

Example: See [Example"Loading pseudorange errors from a file"](#) on page 479.

Manual operation: See ["Error Mode"](#) on page 213

[:SOURCE<hw>]:BB:GNSS:PERRors:CATalog

Queries the names of the pseudorange errors files in the default or in a specific directory. Listed are files with the file extension `*.rs_perr`.

Example: See [Example"Loading pseudorange errors from a file"](#) on page 479.

Manual operation: See ["Pseudorange Errors File"](#) on page 214

```
[ :SOURCE<hw>]:BB:GNSS:SVID<ch>:NAVIC:PRERrors:FILE <Filename>
[ :SOURCE<hw>]:BB:GNSS:SVID<ch>:QZSS:PRERrors:FILE <Filename>
[ :SOURCE<hw>]:BB:GNSS:SVID<ch>:GALileo:PRERrors:FILE <Filename>
[ :SOURCE<hw>]:BB:GNSS:SVID<ch>:GLONASS:PRERrors:FILE <Filename>
[ :SOURCE<hw>]:BB:GNSS:SVID<ch>:SBAS:PRERrors:FILE <Filename>
[ :SOURCE<hw>]:BB:GNSS:SVID<ch>:BEIDOU:PRERrors:FILE <Filename>
[ :SOURCE<hw>]:BB:GNSS:SVID<ch>:GPS:PRERrors:FILE <Filename>
```

Loads a pseudorange error file with extension `*.rs_perr` from the default directory.

Parameters:

<Filename> string

Example: See [Example"Loading pseudorange errors from a file"](#) on page 479.

Manual operation: See ["Pseudorange Errors File"](#) on page 214

```
[ :SOURCE<hw>]:BB:GNSS:SVID<ch>:NAVIC:PRERrors:COPY:SVID <Svid>
[ :SOURCE<hw>]:BB:GNSS:SVID<ch>:QZSS:PRERrors:COPY:SVID <Svid>
[ :SOURCE<hw>]:BB:GNSS:SVID<ch>:GALileo:PRERrors:COPY:SVID <Svid>
[ :SOURCE<hw>]:BB:GNSS:SVID<ch>:GLONASS:PRERrors:COPY:SVID <Svid>
[ :SOURCE<hw>]:BB:GNSS:SVID<ch>:SBAS:PRERrors:COPY:SVID <Svid>
[ :SOURCE<hw>]:BB:GNSS:SVID<ch>:BEIDOU:PRERrors:COPY:SVID <Svid>
[ :SOURCE<hw>]:BB:GNSS:SVID<ch>:GPS:PRERrors:COPY:SVID <Svid>
```

Sets the SV ID to that the configuration form the current satellite (`SVID<ch>`) is applied.

Both SV IDs belong to the same GNSS system.

Parameters:

<Svid> 1 | 2 | 3 | 5 | 4 | 6 | 7 | 8 | 9 | 10 | 11 | 12 | 13 | 14 | 15 | 16 | 17 |
 19 | 18 | 20 | 21 | 22 | 23 | 24 | 25 | 26 | 27 | 28 | 29 | 30 | 31 |
 32 | 33 | 34 | 35 | 36 | 37 | 38 | 39 | 40 | 41 | 42 | 43 | 44 | 45 |
 46 | 47 | 48 | 49 | 50 | 51 | 52 | 53 | 54 | 55 | 56 | 57 | 58 | 59 |
 60 | 61 | 62 | 63 | 64 | 65 | 66 | 67 | 68 | 69 | 70 | 71 | 72 | 73 |
 74 | 75 | 76 | 77 | 78 | 79 | 80 | 81 | 82 | 83 | 84 | 85 | 86 | 87 |
 88 | 89 | 90 | 91 | 92 | 93 | 94 | 95 | 96 | 97 | 98 | 99 | 100 | 101 |
 102 | 103 | 104 | 105 | 106 | 107 | 108 | 109 | 110 | 111 | 112 |
 113 | 114 | 115 | 116 | 117 | 118 | 119 | 120 | 121 | 122 | 123 |
 124 | 125 | 126 | 127 | 128 | 129 | 130 | 131 | 132 | 133 | 134 |
 135 | 136 | 137 | 138 | 139 | 140 | 141 | 142 | 143 | 144 | 145 |
 146 | 147 | 148 | 149 | 150 | 151 | 152 | 153 | 154 | 155 | 156 |
 157 | 158 | 159 | 160 | 161 | 162 | 163 | 164 | 165 | 166 | 167 |
 168 | 169 | 170 | 171 | 172 | 173 | 174 | 175 | 176 | 177 | 178 |
 179 | 180 | 181 | 182 | 183 | 184 | 185 | 186 | 187 | 188 | 189 |
 190 | 191 | 192 | 193 | 194 | 195 | 196 | 197 | 198 | 199 | 200 |
 ALL
 *RST: 1

Example: See [Example"Configuring a pseudorange error ramp"](#) on page 478.

Manual operation: See ["Copy to,SV-ID"](#) on page 213

```
[ :SOURce<hw>]:BB:GNSS:SVID<ch>:NAVic:PRERrors:COPY:EXECute
[:SOURce<hw>]:BB:GNSS:SVID<ch>:QZSS:PRERrors:COPY:EXECute
[:SOURce<hw>]:BB:GNSS:SVID<ch>:GALileo:PRERrors:COPY:EXECute
[:SOURce<hw>]:BB:GNSS:SVID<ch>:GLONass:PRERrors:COPY:EXECute
[:SOURce<hw>]:BB:GNSS:SVID<ch>:SBAS:PRERrors:COPY:EXECute
[:SOURce<hw>]:BB:GNSS:SVID<ch>:BEIDou:PRERrors:COPY:EXECute
[:SOURce<hw>]:BB:GNSS:SVID<ch>:GPS:PRERrors:COPY:EXECute
```

Applies the configuration of the current satellite (SVID<ch>:<GNSS system>) to the satellite defined with the command `[:SOURce<hw>]:BB:GNSS:SVID<ch>:GPS:PRERrors:COPY:SVID`.

Both SV IDs belong to the same GNSS system.

Example: See [Example"Configuring a pseudorange error ramp"](#) on page 478.

Usage: Event

Manual operation: See ["Copy to,SV-ID"](#) on page 213

```
[ :SOURce<hw>]:BB:GNSS:SVID<ch>:NAVic:PRERrors:VALue <PREErrorsValue>
[:SOURce<hw>]:BB:GNSS:SVID<ch>:QZSS:PRERrors:VALue <PREErrorsValue>
[:SOURce<hw>]:BB:GNSS:SVID<ch>:GALileo:PRERrors:VALue <PREErrorsValue>
[:SOURce<hw>]:BB:GNSS:SVID<ch>:GLONass:PRERrors:VALue
<PREErrorsValue>
```

```
[:SOURce<hw>]:BB:GNSS:SVID<ch>:SBAS:PRERrors:VALue <PREErrorsValue>
[:SOURce<hw>]:BB:GNSS:SVID<ch>:BEIDou:PRERrors:VALue <PREErrorsValue>
[:SOURce<hw>]:BB:GNSS:SVID<ch>:GPS:PRERrors:VALue <PREErrorsValue>
```

Sets the constant pseudorange error.

Parameters:

```
<PREErrorsValue> float
                    Range:    -1000 to 1000
                    Increment: 0.001
                    *RST:     0
```

Example:

```
SOURce1:BB:GNSS:SVID1:GPS:PRERrors:MODE Constant
SOURce1:BB:GNSS:SVID11:GPS:PRERrors:VALue -100
```

Manual operation: See ["Value"](#) on page 213

```
[:SOURce<hw>]:BB:GNSS:SVID<ch>:NAVic:PRERrors:PROFile:OFFSet
<ProfileOffset>
[:SOURce<hw>]:BB:GNSS:SVID<ch>:QZSS:PRERrors:PROFile:OFFSet
<ProfileOffset>
[:SOURce<hw>]:BB:GNSS:SVID<ch>:GALileo:PRERrors:PROFile:OFFSet
<ProfileOffset>
[:SOURce<hw>]:BB:GNSS:SVID<ch>:GLONass:PRERrors:PROFile:OFFSet
<ProfileOffset>
[:SOURce<hw>]:BB:GNSS:SVID<ch>:SBAS:PRERrors:PROFile:OFFSet
<ProfileOffset>
[:SOURce<hw>]:BB:GNSS:SVID<ch>:BEIDou:PRERrors:PROFile:OFFSet
<ProfileOffset>
[:SOURce<hw>]:BB:GNSS:SVID<ch>:GPS:PRERrors:PROFile:OFFSet
<ProfileOffset>
```

Adds a start time offset.

Parameters:

```
<ProfileOffset> float
                    Range:    0 to 86400
                    Increment: 0.1
                    *RST:     0
```

Example: See [Example"Configuring a pseudorange error ramp"](#) on page 478.

Manual operation: See ["Start Time Offset"](#) on page 213

```
[:SOURce<hw>]:BB:GNSS:SVID<ch>:NAVic:PRERrors:PROFile:COUNt?
[:SOURce<hw>]:BB:GNSS:SVID<ch>:QZSS:PRERrors:PROFile:COUNt?
[:SOURce<hw>]:BB:GNSS:SVID<ch>:GALileo:PRERrors:PROFile:COUNt?
[:SOURce<hw>]:BB:GNSS:SVID<ch>:GLONass:PRERrors:PROFile:COUNt?
[:SOURce<hw>]:BB:GNSS:SVID<ch>:SBAS:PRERrors:PROFile:COUNt?
```



```
[ :SOURce<hw>]:BB:GNSS:SVID<ch>:BEIDou:PRERrors:PROFile:COUNT?
[:SOURce<hw>]:BB:GNSS:SVID<ch>:GPS:PRERrors:PROFile:COUNT?
```

Queries the number of entry in the profile table.

Return values:

```
<ProfileTableLen> integer
                    Range:    0 to 10
                    *RST:    0
```

Example: See [Example"Configuring a pseudorange error ramp"](#) on page 478.

Usage: Query only

Manual operation: See ["Profile Table"](#) on page 214

```
[ :SOURce<hw>]:BB:GNSS:SVID<ch>:NAVic:PRERrors:PROFile:APPend
[:SOURce<hw>]:BB:GNSS:SVID<ch>:QZSS:PRERrors:PROFile:APPend
[:SOURce<hw>]:BB:GNSS:SVID<ch>:GALileo:PRERrors:PROFile:APPend
[:SOURce<hw>]:BB:GNSS:SVID<ch>:GLONass:PRERrors:PROFile:APPend
[:SOURce<hw>]:BB:GNSS:SVID<ch>:SBAS:PRERrors:PROFile:APPend
[:SOURce<hw>]:BB:GNSS:SVID<ch>:BEIDou:PRERrors:PROFile:APPend
[:SOURce<hw>]:BB:GNSS:SVID<ch>:GPS:PRERrors:PROFile:APPend
```

Appends a row in the profile table.

Setting parameters:

```
<ProfileAppend> Event
```

Example: See [Example"Configuring a pseudorange error ramp"](#) on page 478.

Usage: Event

Manual operation: See ["Profile Table"](#) on page 214

```
[ :SOURce<hw>]:BB:GNSS:SVID<ch>:NAVic:PRERrors:PROFile<gr>:REFerence
<ProfileRefTime>
[:SOURce<hw>]:BB:GNSS:SVID<ch>:QZSS:PRERrors:PROFile<gr>:REFerence
<ProfileRefTime>
[:SOURce<hw>]:BB:GNSS:SVID<ch>:GALileo:PRERrors:PROFile<gr>:
REFerence <ProfileRefTime>
[:SOURce<hw>]:BB:GNSS:SVID<ch>:GLONass:PRERrors:PROFile<gr>:
REFerence <ProfileRefTime>
[:SOURce<hw>]:BB:GNSS:SVID<ch>:SBAS:PRERrors:PROFile<gr>:REFerence
<ProfileRefTime>
[:SOURce<hw>]:BB:GNSS:SVID<ch>:BEIDou:PRERrors:PROFile<gr>:REFerence
<ProfileRefTime>
[:SOURce<hw>]:BB:GNSS:SVID<ch>:GLONass:PRERrors:PROFile<gr>:
REFerence <ProfileRefTime>
```

[[:SOURce<hw>]:BB:GNSS:SVID<ch>:SBAS:PRERrors:PROFile<gr>:REfERENCE
 <ProfileRefTime>

[[:SOURce<hw>]:BB:GNSS:SVID<ch>:GPS:PRERrors:PROFile<gr>:REfERENCE
 <ProfileRefTime>

Sets the reference time for the pseudorange error.

Suffix:

<gr> 1 to 10
 Pseudorange error

Parameters:

<ProfileRefTime> float
 Range: 0 to 86400
 Increment: 0.1
 *RST: 0

Example: See [Example"Configuring a pseudorange error ramp"](#) on page 478.

Manual operation: See "[Profile Table](#)" on page 214

[[:SOURce<hw>]:BB:GNSS:SVID<ch>:NAVic:PRERrors:PROFile<gr>:VALue
 <ProfileValue>

[[:SOURce<hw>]:BB:GNSS:SVID<ch>:QZSS:PRERrors:PROFile<gr>:VALue
 <ProfileValue>

[[:SOURce<hw>]:BB:GNSS:SVID<ch>:GALileo:PRERrors:PROFile<gr>:VALue
 <ProfileValue>

[[:SOURce<hw>]:BB:GNSS:SVID<ch>:GLONass:PRERrors:PROFile<gr>:VALue
 <ProfileValue>

[[:SOURce<hw>]:BB:GNSS:SVID<ch>:SBAS:PRERrors:PROFile<gr>:VALue
 <ProfileValue>

[[:SOURce<hw>]:BB:GNSS:SVID<ch>:BEIDou:PRERrors:PROFile<gr>:VALue
 <ProfileValue>

[[:SOURce<hw>]:BB:GNSS:SVID<ch>:GPS:PRERrors:PROFile<gr>:VALue
 <ProfileValue>

Sets the pseudorange error value.

Suffix:

<gr> 1 to 10
 Pseudorange error

Parameters:

<ProfileValue> float
 Range: -1000 to 1000
 Increment: 0.001
 *RST: 0

Example: See [Example"Configuring a pseudorange error ramp"](#) on page 478.

Manual operation: See "[Profile Table](#)" on page 214

```
[:SOURCE<hw>]:BB:GNSS:SVID<ch>:NAVic:PRERrors:PROFile<gr>:INSert
[:SOURCE<hw>]:BB:GNSS:SVID<ch>:QZSS:PRERrors:PROFile<gr>:INSert
[:SOURCE<hw>]:BB:GNSS:SVID<ch>:GALileo:PRERrors:PROFile<gr>:INSert
[:SOURCE<hw>]:BB:GNSS:SVID<ch>:GLONass:PRERrors:PROFile<gr>:INSert
[:SOURCE<hw>]:BB:GNSS:SVID<ch>:SBAS:PRERrors:PROFile<gr>:INSert
[:SOURCE<hw>]:BB:GNSS:SVID<ch>:BEIDou:PRERrors:PROFile<gr>:INSert
[:SOURCE<hw>]:BB:GNSS:SVID<ch>:GPS:PRERrors:PROFile<gr>:INSert
```

Inserts a row before the selected pseudorange error.

Suffix:

<gr> 1 to 10
Pseudorange error

Setting parameters:

<ProfileInsert> Event

Example:

```
SOURce1:BB:GNSS:SVID1:GPS:PRERrors:COUNT?
// 5
SOURce1:BB:GNSS:SVID1:GPS:PRERrors:PROFile5:INSert
// insert a row before the last one
SOURce1:BB:GNSS:SVID1:GPS:PRERrors:COUNT?
// 6
```

Usage: Event

Manual operation: See "[Profile Table](#)" on page 214

```
[:SOURCE<hw>]:BB:GNSS:SVID<ch>:NAVic:PRERrors:PROFile<gr>:DELeTe
[:SOURCE<hw>]:BB:GNSS:SVID<ch>:QZSS:PRERrors:PROFile<gr>:DELeTe
[:SOURCE<hw>]:BB:GNSS:SVID<ch>:GALileo:PRERrors:PROFile<gr>:DELeTe
[:SOURCE<hw>]:BB:GNSS:SVID<ch>:GLONass:PRERrors:PROFile<gr>:DELeTe
[:SOURCE<hw>]:BB:GNSS:SVID<ch>:SBAS:PRERrors:PROFile<gr>:DELeTe
[:SOURCE<hw>]:BB:GNSS:SVID<ch>:BEIDou:PRERrors:PROFile<gr>:DELeTe
[:SOURCE<hw>]:BB:GNSS:SVID<ch>:GPS:PRERrors:PROFile<gr>:DELeTe
```

Deletes the selected pseudorange error.

Suffix:

<gr> 1 to 10
Pseudorange error

Setting parameters:

<ProfileDelete> Event

Example: See [Example "Configuring a pseudorange error ramp"](#)
on page 478.

Usage: Event

Manual operation: See "[Profile Table](#)" on page 214

22.13.3 Orbit, clock, system, time conversion and ionospheric errors

[:SOURCE<hw>]:BB:GNSS:SVID<ch>:GALileo:NMESsage:FNAV:EPHemeris:IODNav.....	521
[:SOURCE<hw>]:BB:GNSS:SVID<ch>:GALileo:NMESsage:INAV:EPHemeris:IODNav.....	521
[:SOURCE<hw>]:BB:GNSS:SVID<ch>:NAVic:NMESsage:NAV:EPHemeris:IODE.....	521
[:SOURCE<hw>]:BB:GNSS:SVID<ch>:QZSS:NMESsage:NAV:EPHemeris:IODE.....	521
[:SOURCE<hw>]:BB:GNSS:SVID<ch>:BEIDou:NMESsage:DNAV:EPHemeris:IODE.....	521
[:SOURCE<hw>]:BB:GNSS:SVID<ch>:GPS:NMESsage:LNAV:EPHemeris:IODE.....	521
[:SOURCE<hw>]:BB:GNSS:SVID<ch>:SBAS:NMESsage:NAV:EPHemeris:TOE:UNSCaled...	521
[:SOURCE<hw>]:BB:GNSS:SVID<ch>:SBAS:NMESsage:NAV:EPHemeris:TOE.....	521
[:SOURCE<hw>]:BB:GNSS:SVID<ch>:NAVic:NMESsage:NAV:EPHemeris:TOE:UNSCaled...	521
[:SOURCE<hw>]:BB:GNSS:SVID<ch>:NAVic:NMESsage:NAV:EPHemeris:TOE.....	521
[:SOURCE<hw>]:BB:GNSS:SVID<ch>:QZSS:NMESsage:CNAV:EPHemeris:TOE: UNSCaled.....	521
[:SOURCE<hw>]:BB:GNSS:SVID<ch>:QZSS:NMESsage:CNAV:EPHemeris:TOE.....	521
[:SOURCE<hw>]:BB:GNSS:SVID<ch>:QZSS:NMESsage:NAV:EPHemeris:TOE:UNSCaled...	521
[:SOURCE<hw>]:BB:GNSS:SVID<ch>:QZSS:NMESsage:NAV:EPHemeris:TOE.....	521
[:SOURCE<hw>]:BB:GNSS:SVID<ch>:GALileo:NMESsage:FNAV:EPHemeris:TOE: UNSCaled.....	521
[:SOURCE<hw>]:BB:GNSS:SVID<ch>:GALileo:NMESsage:FNAV:EPHemeris:TOE.....	521
[:SOURCE<hw>]:BB:GNSS:SVID<ch>:GALileo:NMESsage:INAV:EPHemeris:TOE: UNSCaled.....	522
[:SOURCE<hw>]:BB:GNSS:SVID<ch>:GALileo:NMESsage:INAV:EPHemeris:TOE.....	522
[:SOURCE<hw>]:BB:GNSS:SVID<ch>:BEIDou:NMESsage:CNAV:EPHemeris:TOE: UNSCaled.....	522
[:SOURCE<hw>]:BB:GNSS:SVID<ch>:BEIDou:NMESsage:CNAV:EPHemeris:TOE.....	522
[:SOURCE<hw>]:BB:GNSS:SVID<ch>:BEIDou:NMESsage:DNAV:EPHemeris:TOE: UNSCaled.....	522
[:SOURCE<hw>]:BB:GNSS:SVID<ch>:BEIDou:NMESsage:DNAV:EPHemeris:TOE.....	522
[:SOURCE<hw>]:BB:GNSS:SVID<ch>:GPS:NMESsage:CNAV:EPHemeris:TOE:UNSCaled..	522
[:SOURCE<hw>]:BB:GNSS:SVID<ch>:GPS:NMESsage:CNAV:EPHemeris:TOE.....	522
[:SOURCE<hw>]:BB:GNSS:SVID<ch>:GPS:NMESsage:LNAV:EPHemeris:TOE:UNSCaled...	522
[:SOURCE<hw>]:BB:GNSS:SVID<ch>:GPS:NMESsage:LNAV:EPHemeris:TOE.....	522
[:SOURCE<hw>]:BB:GNSS:SVID<ch>:NAVic:NMESsage:NAV:EPHemeris:SQRA: UNSCaled.....	522
[:SOURCE<hw>]:BB:GNSS:SVID<ch>:NAVic:NMESsage:NAV:EPHemeris:SQRA.....	522
[:SOURCE<hw>]:BB:GNSS:SVID<ch>:QZSS:NMESsage:CNAV:EPHemeris:SQRA: UNSCaled.....	522
[:SOURCE<hw>]:BB:GNSS:SVID<ch>:QZSS:NMESsage:CNAV:EPHemeris:SQRA.....	522
[:SOURCE<hw>]:BB:GNSS:SVID<ch>:QZSS:NMESsage:NAV:EPHemeris:SQRA: UNSCaled.....	522
[:SOURCE<hw>]:BB:GNSS:SVID<ch>:QZSS:NMESsage:NAV:EPHemeris:SQRA.....	522
[:SOURCE<hw>]:BB:GNSS:SVID<ch>:GALileo:NMESsage:FNAV:EPHemeris:SQRA: UNSCaled.....	522
[:SOURCE<hw>]:BB:GNSS:SVID<ch>:GALileo:NMESsage:FNAV:EPHemeris:SQRA.....	522
[:SOURCE<hw>]:BB:GNSS:SVID<ch>:GALileo:NMESsage:INAV:EPHemeris:SQRA: UNSCaled.....	522
[:SOURCE<hw>]:BB:GNSS:SVID<ch>:GALileo:NMESsage:INAV:EPHemeris:SQRA.....	522
[:SOURCE<hw>]:BB:GNSS:SVID<ch>:BEIDou:NMESsage:CNAV:EPHemeris:SQRA: UNSCaled.....	522

Navigation message commands

[:SOURce<hw>]:BB:GNSS:SVID<ch>:BEIDou:NMESsage:CNAV:EPHemeris:SQRA.....523
 [:SOURce<hw>]:BB:GNSS:SVID<ch>:BEIDou:NMESsage:DNAV:EPHemeris:SQRA:
 UNSCaled.....523
 [:SOURce<hw>]:BB:GNSS:SVID<ch>:BEIDou:NMESsage:DNAV:EPHemeris:SQRA.....523
 [:SOURce<hw>]:BB:GNSS:SVID<ch>:GPS:NMESsage:CNAV:EPHemeris:SQRA:
 UNSCaled.....523
 [:SOURce<hw>]:BB:GNSS:SVID<ch>:GPS:NMESsage:CNAV:EPHemeris:SQRA.....523
 [:SOURce<hw>]:BB:GNSS:SVID<ch>:GPS:NMESsage:LNAV:EPHemeris:SQRA:
 UNSCaled.....523
 [:SOURce<hw>]:BB:GNSS:SVID<ch>:GPS:NMESsage:LNAV:EPHemeris:SQRA.....523
 [:SOURce<hw>]:BB:GNSS:SVID<ch>:NAVic:NMESsage:NAV:EPHemeris:ECCentricity:
 UNSCaled.....523
 [:SOURce<hw>]:BB:GNSS:SVID<ch>:NAVic:NMESsage:NAV:EPHemeris:ECCentricity.....523
 [:SOURce<hw>]:BB:GNSS:SVID<ch>:QZSS:NMESsage:CNAV:EPHemeris:
 ECCentricity:UNSCaled.....523
 [:SOURce<hw>]:BB:GNSS:SVID<ch>:QZSS:NMESsage:CNAV:EPHemeris:ECCentricity.....523
 [:SOURce<hw>]:BB:GNSS:SVID<ch>:QZSS:NMESsage:NAV:EPHemeris:ECCentricity:
 UNSCaled.....523
 [:SOURce<hw>]:BB:GNSS:SVID<ch>:QZSS:NMESsage:NAV:EPHemeris:ECCentricity.....523
 [:SOURce<hw>]:BB:GNSS:SVID<ch>:GALileo:NMESsage:FNAV:EPHemeris:
 ECCentricity:UNSCaled.....523
 [:SOURce<hw>]:BB:GNSS:SVID<ch>:GALileo:NMESsage:FNAV:EPHemeris:ECCentricity...523
 [:SOURce<hw>]:BB:GNSS:SVID<ch>:GALileo:NMESsage:INAV:EPHemeris:
 ECCentricity:UNSCaled.....523
 [:SOURce<hw>]:BB:GNSS:SVID<ch>:GALileo:NMESsage:INAV:EPHemeris:ECCentricity....523
 [:SOURce<hw>]:BB:GNSS:SVID<ch>:BEIDou:NMESsage:CNAV:EPHemeris:
 ECCentricity:UNSCaled.....523
 [:SOURce<hw>]:BB:GNSS:SVID<ch>:BEIDou:NMESsage:CNAV:EPHemeris:ECCentricity...523
 [:SOURce<hw>]:BB:GNSS:SVID<ch>:BEIDou:NMESsage:DNAV:EPHemeris:
 ECCentricity:UNSCaled.....523
 [:SOURce<hw>]:BB:GNSS:SVID<ch>:BEIDou:NMESsage:DNAV:EPHemeris:ECCentricity...523
 [:SOURce<hw>]:BB:GNSS:SVID<ch>:GPS:NMESsage:CNAV:EPHemeris:ECCentricity:
 UNSCaled.....524
 [:SOURce<hw>]:BB:GNSS:SVID<ch>:GPS:NMESsage:CNAV:EPHemeris:ECCentricity.....524
 [:SOURce<hw>]:BB:GNSS:SVID<ch>:GPS:NMESsage:LNAV:EPHemeris:ECCentricity:
 UNSCaled.....524
 [:SOURce<hw>]:BB:GNSS:SVID<ch>:GPS:NMESsage:LNAV:EPHemeris:ECCentricity.....524
 [:SOURce<hw>]:BB:GNSS:SVID<ch>:NAVic:NMESsage:NAV:EPHemeris:IZERo:
 UNSCaled.....524
 [:SOURce<hw>]:BB:GNSS:SVID<ch>:NAVic:NMESsage:NAV:EPHemeris:IZERo.....524
 [:SOURce<hw>]:BB:GNSS:SVID<ch>:QZSS:NMESsage:CNAV:EPHemeris:IZERo:
 UNSCaled.....524
 [:SOURce<hw>]:BB:GNSS:SVID<ch>:QZSS:NMESsage:CNAV:EPHemeris:IZERo.....524
 [:SOURce<hw>]:BB:GNSS:SVID<ch>:QZSS:NMESsage:NAV:EPHemeris:IZERo:
 UNSCaled.....524
 [:SOURce<hw>]:BB:GNSS:SVID<ch>:QZSS:NMESsage:NAV:EPHemeris:IZERo.....524
 [:SOURce<hw>]:BB:GNSS:SVID<ch>:GALileo:NMESsage:FNAV:EPHemeris:IZERo:
 UNSCaled.....524
 [:SOURce<hw>]:BB:GNSS:SVID<ch>:GALileo:NMESsage:FNAV:EPHemeris:IZERo.....524

Navigation message commands

[:SOURce<hw>]:BB:GNSS:SVID<ch>:GALileo:NMESsage:INAV:EPHemeris:IZERo: UNSCaled.....	524
[:SOURce<hw>]:BB:GNSS:SVID<ch>:GALileo:NMESsage:INAV:EPHemeris:IZERo.....	524
[:SOURce<hw>]:BB:GNSS:SVID<ch>:BEIDou:NMESsage:CNAV:EPHemeris:IZERo: UNSCaled.....	524
[:SOURce<hw>]:BB:GNSS:SVID<ch>:BEIDou:NMESsage:CNAV:EPHemeris:IZERo.....	524
[:SOURce<hw>]:BB:GNSS:SVID<ch>:BEIDou:NMESsage:DNAV:EPHemeris:IZERo: UNSCaled.....	524
[:SOURce<hw>]:BB:GNSS:SVID<ch>:BEIDou:NMESsage:DNAV:EPHemeris:IZERo.....	524
[:SOURce<hw>]:BB:GNSS:SVID<ch>:GPS:NMESsage:CNAV:EPHemeris:IZERo: UNSCaled.....	524
[:SOURce<hw>]:BB:GNSS:SVID<ch>:GPS:NMESsage:CNAV:EPHemeris:IZERo.....	524
[:SOURce<hw>]:BB:GNSS:SVID<ch>:GPS:NMESsage:LNAV:EPHemeris:IZERo: UNSCaled.....	525
[:SOURce<hw>]:BB:GNSS:SVID<ch>:GPS:NMESsage:LNAV:EPHemeris:IZERo.....	525
[:SOURce<hw>]:BB:GNSS:SVID<ch>:NAVic:NMESsage:NAV:EPHemeris:OZERo: UNSCaled.....	525
[:SOURce<hw>]:BB:GNSS:SVID<ch>:NAVic:NMESsage:NAV:EPHemeris:OZERo.....	525
[:SOURce<hw>]:BB:GNSS:SVID<ch>:QZSS:NMESsage:CNAV:EPHemeris:OZERo: UNSCaled.....	525
[:SOURce<hw>]:BB:GNSS:SVID<ch>:QZSS:NMESsage:CNAV:EPHemeris:OZERo.....	525
[:SOURce<hw>]:BB:GNSS:SVID<ch>:QZSS:NMESsage:NAV:EPHemeris:OZERo: UNSCaled.....	525
[:SOURce<hw>]:BB:GNSS:SVID<ch>:QZSS:NMESsage:NAV:EPHemeris:OZERo.....	525
[:SOURce<hw>]:BB:GNSS:SVID<ch>:GALileo:NMESsage:FNAV:EPHemeris:OZERo: UNSCaled.....	525
[:SOURce<hw>]:BB:GNSS:SVID<ch>:GALileo:NMESsage:FNAV:EPHemeris:OZERo.....	525
[:SOURce<hw>]:BB:GNSS:SVID<ch>:GALileo:NMESsage:INAV:EPHemeris:OZERo: UNSCaled.....	525
[:SOURce<hw>]:BB:GNSS:SVID<ch>:GALileo:NMESsage:INAV:EPHemeris:OZERo.....	525
[:SOURce<hw>]:BB:GNSS:SVID<ch>:BEIDou:NMESsage:CNAV:EPHemeris:OZERo: UNSCaled.....	525
[:SOURce<hw>]:BB:GNSS:SVID<ch>:BEIDou:NMESsage:CNAV:EPHemeris:OZERo.....	525
[:SOURce<hw>]:BB:GNSS:SVID<ch>:BEIDou:NMESsage:DNAV:EPHemeris:OZERo: UNSCaled.....	525
[:SOURce<hw>]:BB:GNSS:SVID<ch>:BEIDou:NMESsage:DNAV:EPHemeris:OZERo.....	525
[:SOURce<hw>]:BB:GNSS:SVID<ch>:GPS:NMESsage:CNAV:EPHemeris:OZERo: UNSCaled.....	525
[:SOURce<hw>]:BB:GNSS:SVID<ch>:GPS:NMESsage:CNAV:EPHemeris:OZERo.....	525
[:SOURce<hw>]:BB:GNSS:SVID<ch>:GPS:NMESsage:LNAV:EPHemeris:OZERo: UNSCaled.....	525
[:SOURce<hw>]:BB:GNSS:SVID<ch>:GPS:NMESsage:LNAV:EPHemeris:OZERo.....	525
[:SOURce<hw>]:BB:GNSS:SVID<ch>:NAVic:NMESsage:NAV:EPHemeris:OMEGa: UNSCaled.....	526
[:SOURce<hw>]:BB:GNSS:SVID<ch>:NAVic:NMESsage:NAV:EPHemeris:OMEGa.....	526
[:SOURce<hw>]:BB:GNSS:SVID<ch>:QZSS:NMESsage:CNAV:EPHemeris:OMEGa: UNSCaled.....	526
[:SOURce<hw>]:BB:GNSS:SVID<ch>:QZSS:NMESsage:CNAV:EPHemeris:OMEGa.....	526
[:SOURce<hw>]:BB:GNSS:SVID<ch>:QZSS:NMESsage:NAV:EPHemeris:OMEGa: UNSCaled.....	526

Navigation message commands

[:SOURce<hw>]:BB:GNSS:SVID<ch>:QZSS:NMESsage:NAV:EPHemeris:OMEGa.....	526
[:SOURce<hw>]:BB:GNSS:SVID<ch>:GALileo:NMESsage:FNAV:EPHemeris:OMEGa: UNSCaled.....	526
[:SOURce<hw>]:BB:GNSS:SVID<ch>:GALileo:NMESsage:FNAV:EPHemeris:OMEGa.....	526
[:SOURce<hw>]:BB:GNSS:SVID<ch>:GALileo:NMESsage:INAV:EPHemeris:OMEGa: UNSCaled.....	526
[:SOURce<hw>]:BB:GNSS:SVID<ch>:GALileo:NMESsage:INAV:EPHemeris:OMEGa.....	526
[:SOURce<hw>]:BB:GNSS:SVID<ch>:BEIDou:NMESsage:CNAV:EPHemeris:OMEGa: UNSCaled.....	526
[:SOURce<hw>]:BB:GNSS:SVID<ch>:BEIDou:NMESsage:CNAV:EPHemeris:OMEGa.....	526
[:SOURce<hw>]:BB:GNSS:SVID<ch>:BEIDou:NMESsage:DNAV:EPHemeris:OMEGa: UNSCaled.....	526
[:SOURce<hw>]:BB:GNSS:SVID<ch>:BEIDou:NMESsage:DNAV:EPHemeris:OMEGa.....	526
[:SOURce<hw>]:BB:GNSS:SVID<ch>:GPS:NMESsage:CNAV:EPHemeris:OMEGa: UNSCaled.....	526
[:SOURce<hw>]:BB:GNSS:SVID<ch>:GPS:NMESsage:CNAV:EPHemeris:OMEGa.....	526
[:SOURce<hw>]:BB:GNSS:SVID<ch>:GPS:NMESsage:LNAV:EPHemeris:OMEGa: UNSCaled.....	526
[:SOURce<hw>]:BB:GNSS:SVID<ch>:GPS:NMESsage:LNAV:EPHemeris:OMEGa.....	526
[:SOURce<hw>]:BB:GNSS:SVID<ch>:NAVic:NMESsage:NAV:EPHemeris:MZERo: UNSCaled.....	527
[:SOURce<hw>]:BB:GNSS:SVID<ch>:NAVic:NMESsage:NAV:EPHemeris:MZERo.....	527
[:SOURce<hw>]:BB:GNSS:SVID<ch>:QZSS:NMESsage:CNAV:EPHemeris:MZERo: UNSCaled.....	527
[:SOURce<hw>]:BB:GNSS:SVID<ch>:QZSS:NMESsage:CNAV:EPHemeris:MZERo.....	527
[:SOURce<hw>]:BB:GNSS:SVID<ch>:QZSS:NMESsage:NAV:EPHemeris:MZERo: UNSCaled.....	527
[:SOURce<hw>]:BB:GNSS:SVID<ch>:QZSS:NMESsage:NAV:EPHemeris:MZERo.....	527
[:SOURce<hw>]:BB:GNSS:SVID<ch>:GALileo:NMESsage:FNAV:EPHemeris:MZERo: UNSCaled.....	527
[:SOURce<hw>]:BB:GNSS:SVID<ch>:GALileo:NMESsage:FNAV:EPHemeris:MZERo.....	527
[:SOURce<hw>]:BB:GNSS:SVID<ch>:GALileo:NMESsage:INAV:EPHemeris:MZERo: UNSCaled.....	527
[:SOURce<hw>]:BB:GNSS:SVID<ch>:GALileo:NMESsage:INAV:EPHemeris:MZERo.....	527
[:SOURce<hw>]:BB:GNSS:SVID<ch>:BEIDou:NMESsage:CNAV:EPHemeris:MZERo: UNSCaled.....	527
[:SOURce<hw>]:BB:GNSS:SVID<ch>:BEIDou:NMESsage:CNAV:EPHemeris:MZERo.....	527
[:SOURce<hw>]:BB:GNSS:SVID<ch>:BEIDou:NMESsage:DNAV:EPHemeris:MZERo: UNSCaled.....	527
[:SOURce<hw>]:BB:GNSS:SVID<ch>:BEIDou:NMESsage:DNAV:EPHemeris:MZERo.....	527
[:SOURce<hw>]:BB:GNSS:SVID<ch>:GPS:NMESsage:CNAV:EPHemeris:MZERo: UNSCaled.....	527
[:SOURce<hw>]:BB:GNSS:SVID<ch>:GPS:NMESsage:CNAV:EPHemeris:MZERo.....	527
[:SOURce<hw>]:BB:GNSS:SVID<ch>:GPS:NMESsage:LNAV:EPHemeris:MZERo: UNSCaled.....	527
[:SOURce<hw>]:BB:GNSS:SVID<ch>:GPS:NMESsage:LNAV:EPHemeris:MZERo.....	527
[:SOURce<hw>]:BB:GNSS:SVID<ch>:NAVic:NMESsage:NAV:EPHemeris:IDOT:UNSCaled..	527
[:SOURce<hw>]:BB:GNSS:SVID<ch>:NAVic:NMESsage:NAV:EPHemeris:IDOT.....	527
[:SOURce<hw>]:BB:GNSS:SVID<ch>:QZSS:NMESsage:CNAV:EPHemeris:IDOT: UNSCaled.....	527

Navigation message commands

[:SOURCE<hw>]:BB:GNSS:SVID<ch>:QZSS:NMESSage:CNAV:EPHemeris:IDOT.....	528
[:SOURCE<hw>]:BB:GNSS:SVID<ch>:QZSS:NMESSage:NAV:EPHemeris:IDOT:UNSCaled..	528
[:SOURCE<hw>]:BB:GNSS:SVID<ch>:QZSS:NMESSage:NAV:EPHemeris:IDOT.....	528
[:SOURCE<hw>]:BB:GNSS:SVID<ch>:GALileo:NMESSage:FNAV:EPHemeris:IDOT: UNSCaled.....	528
[:SOURCE<hw>]:BB:GNSS:SVID<ch>:GALileo:NMESSage:FNAV:EPHemeris:IDOT.....	528
[:SOURCE<hw>]:BB:GNSS:SVID<ch>:GALileo:NMESSage:INAV:EPHemeris:IDOT: UNSCaled.....	528
[:SOURCE<hw>]:BB:GNSS:SVID<ch>:GALileo:NMESSage:INAV:EPHemeris:IDOT.....	528
[:SOURCE<hw>]:BB:GNSS:SVID<ch>:BEIDou:NMESSage:CNAV:EPHemeris:IDOT: UNSCaled.....	528
[:SOURCE<hw>]:BB:GNSS:SVID<ch>:BEIDou:NMESSage:CNAV:EPHemeris:IDOT.....	528
[:SOURCE<hw>]:BB:GNSS:SVID<ch>:BEIDou:NMESSage:DNAV:EPHemeris:IDOT: UNSCaled.....	528
[:SOURCE<hw>]:BB:GNSS:SVID<ch>:BEIDou:NMESSage:DNAV:EPHemeris:IDOT.....	528
[:SOURCE<hw>]:BB:GNSS:SVID<ch>:GPS:NMESSage:CNAV:EPHemeris:IDOT:UNSCaled..	528
[:SOURCE<hw>]:BB:GNSS:SVID<ch>:GPS:NMESSage:CNAV:EPHemeris:IDOT.....	528
[:SOURCE<hw>]:BB:GNSS:SVID<ch>:GPS:NMESSage:LNAV:EPHemeris:IDOT:UNSCaled..	528
[:SOURCE<hw>]:BB:GNSS:SVID<ch>:GPS:NMESSage:LNAV:EPHemeris:IDOT.....	528
[:SOURCE<hw>]:BB:GNSS:SVID<ch>:NAVic:NMESSage:NAV:EPHemeris:ODOT: UNSCaled.....	528
[:SOURCE<hw>]:BB:GNSS:SVID<ch>:NAVic:NMESSage:NAV:EPHemeris:ODOT.....	528
[:SOURCE<hw>]:BB:GNSS:SVID<ch>:QZSS:NMESSage:CNAV:EPHemeris:ODOT: UNSCaled.....	528
[:SOURCE<hw>]:BB:GNSS:SVID<ch>:QZSS:NMESSage:CNAV:EPHemeris:ODOT.....	528
[:SOURCE<hw>]:BB:GNSS:SVID<ch>:QZSS:NMESSage:NAV:EPHemeris:ODOT: UNSCaled.....	528
[:SOURCE<hw>]:BB:GNSS:SVID<ch>:QZSS:NMESSage:NAV:EPHemeris:ODOT.....	528
[:SOURCE<hw>]:BB:GNSS:SVID<ch>:GALileo:NMESSage:FNAV:EPHemeris:ODOT: UNSCaled.....	529
[:SOURCE<hw>]:BB:GNSS:SVID<ch>:GALileo:NMESSage:FNAV:EPHemeris:ODOT.....	529
[:SOURCE<hw>]:BB:GNSS:SVID<ch>:GALileo:NMESSage:INAV:EPHemeris:ODOT: UNSCaled.....	529
[:SOURCE<hw>]:BB:GNSS:SVID<ch>:GALileo:NMESSage:INAV:EPHemeris:ODOT.....	529
[:SOURCE<hw>]:BB:GNSS:SVID<ch>:BEIDou:NMESSage:CNAV:EPHemeris:ODOT: UNSCaled.....	529
[:SOURCE<hw>]:BB:GNSS:SVID<ch>:BEIDou:NMESSage:CNAV:EPHemeris:ODOT.....	529
[:SOURCE<hw>]:BB:GNSS:SVID<ch>:BEIDou:NMESSage:DNAV:EPHemeris:ODOT: UNSCaled.....	529
[:SOURCE<hw>]:BB:GNSS:SVID<ch>:BEIDou:NMESSage:DNAV:EPHemeris:ODOT.....	529
[:SOURCE<hw>]:BB:GNSS:SVID<ch>:GPS:NMESSage:CNAV:EPHemeris:ODOT: UNSCaled.....	529
[:SOURCE<hw>]:BB:GNSS:SVID<ch>:GPS:NMESSage:CNAV:EPHemeris:ODOT.....	529
[:SOURCE<hw>]:BB:GNSS:SVID<ch>:GPS:NMESSage:LNAV:EPHemeris:ODOT: UNSCaled.....	529
[:SOURCE<hw>]:BB:GNSS:SVID<ch>:GPS:NMESSage:LNAV:EPHemeris:ODOT.....	529
[:SOURCE<hw>]:BB:GNSS:SVID<ch>:QZSS:NMESSage:CNAV:EPHemeris:DODot: UNSCaled.....	529
[:SOURCE<hw>]:BB:GNSS:SVID<ch>:QZSS:NMESSage:CNAV:EPHemeris:DODot.....	529

Navigation message commands

[:SOURce<hw>]:BB:GNSS:SVID<ch>:GPS:NMESSage:CNAV:EPHemeris:DODot: UNSCaled.....	529
[:SOURce<hw>]:BB:GNSS:SVID<ch>:GPS:NMESSage:CNAV:EPHemeris:DODot.....	529
[:SOURce<hw>]:BB:GNSS:SVID<ch>:NAVic:NMESSage:NAV:EPHemeris:NDELta: UNSCaled.....	529
[:SOURce<hw>]:BB:GNSS:SVID<ch>:NAVic:NMESSage:NAV:EPHemeris:NDELta.....	529
[:SOURce<hw>]:BB:GNSS:SVID<ch>:QZSS:NMESSage:CNAV:EPHemeris:NDELta: UNSCaled.....	530
[:SOURce<hw>]:BB:GNSS:SVID<ch>:QZSS:NMESSage:CNAV:EPHemeris:NDELta.....	530
[:SOURce<hw>]:BB:GNSS:SVID<ch>:QZSS:NMESSage:NAV:EPHemeris:NDELta: UNSCaled.....	530
[:SOURce<hw>]:BB:GNSS:SVID<ch>:QZSS:NMESSage:NAV:EPHemeris:NDELta.....	530
[:SOURce<hw>]:BB:GNSS:SVID<ch>:GALileo:NMESSage:FNAV:EPHemeris:NDELta: UNSCaled.....	530
[:SOURce<hw>]:BB:GNSS:SVID<ch>:GALileo:NMESSage:FNAV:EPHemeris:NDELta.....	530
[:SOURce<hw>]:BB:GNSS:SVID<ch>:GALileo:NMESSage:INAV:EPHemeris:NDELta: UNSCaled.....	530
[:SOURce<hw>]:BB:GNSS:SVID<ch>:GALileo:NMESSage:INAV:EPHemeris:NDELta.....	530
[:SOURce<hw>]:BB:GNSS:SVID<ch>:BEIDou:NMESSage:CNAV:EPHemeris:NDELta: UNSCaled.....	530
[:SOURce<hw>]:BB:GNSS:SVID<ch>:BEIDou:NMESSage:CNAV:EPHemeris:NDELta.....	530
[:SOURce<hw>]:BB:GNSS:SVID<ch>:BEIDou:NMESSage:DNAV:EPHemeris:NDELta: UNSCaled.....	530
[:SOURce<hw>]:BB:GNSS:SVID<ch>:BEIDou:NMESSage:DNAV:EPHemeris:NDELta.....	530
[:SOURce<hw>]:BB:GNSS:SVID<ch>:GPS:NMESSage:CNAV:EPHemeris:NDELta: UNSCaled.....	530
[:SOURce<hw>]:BB:GNSS:SVID<ch>:GPS:NMESSage:CNAV:EPHemeris:NDELta.....	530
[:SOURce<hw>]:BB:GNSS:SVID<ch>:GPS:NMESSage:LNAV:EPHemeris:NDELta: UNSCaled.....	530
[:SOURce<hw>]:BB:GNSS:SVID<ch>:GPS:NMESSage:LNAV:EPHemeris:NDELta.....	530
[:SOURce<hw>]:BB:GNSS:SVID<ch>:QZSS:NMESSage:CNAV:EPHemeris:DNDot: UNSCaled.....	530
[:SOURce<hw>]:BB:GNSS:SVID<ch>:QZSS:NMESSage:CNAV:EPHemeris:DNDot.....	530
[:SOURce<hw>]:BB:GNSS:SVID<ch>:BEIDou:NMESSage:CNAV:EPHemeris:DNDot: UNSCaled.....	530
[:SOURce<hw>]:BB:GNSS:SVID<ch>:BEIDou:NMESSage:CNAV:EPHemeris:DNDot.....	530
[:SOURce<hw>]:BB:GNSS:SVID<ch>:GPS:NMESSage:CNAV:EPHemeris:DNDot: UNSCaled.....	531
[:SOURce<hw>]:BB:GNSS:SVID<ch>:GPS:NMESSage:CNAV:EPHemeris:DNDot.....	531
[:SOURce<hw>]:BB:GNSS:SVID<ch>:QZSS:NMESSage:CNAV:EPHemeris:ADOT: UNSCaled.....	531
[:SOURce<hw>]:BB:GNSS:SVID<ch>:QZSS:NMESSage:CNAV:EPHemeris:ADOT.....	531
[:SOURce<hw>]:BB:GNSS:SVID<ch>:BEIDou:NMESSage:CNAV:EPHemeris:ADOT: UNSCaled.....	531
[:SOURce<hw>]:BB:GNSS:SVID<ch>:BEIDou:NMESSage:CNAV:EPHemeris:ADOT.....	531
[:SOURce<hw>]:BB:GNSS:SVID<ch>:GPS:NMESSage:CNAV:EPHemeris:ADOT: UNSCaled.....	531
[:SOURce<hw>]:BB:GNSS:SVID<ch>:GPS:NMESSage:CNAV:EPHemeris:ADOT.....	531
[:SOURce<hw>]:BB:GNSS:SVID<ch>:QZSS:NMESSage:CNAV:EPHemeris:ADELta: UNSCaled.....	531

Navigation message commands

[:SOURce<hw>]:BB:GNSS:SVID<ch>:QZSS:NMESsage:CNAV:EPHemeris:ADELta.....	531
[:SOURce<hw>]:BB:GNSS:SVID<ch>:BEIDou:NMESsage:CNAV:EPHemeris:ADELta: UNSCaled.....	531
[:SOURce<hw>]:BB:GNSS:SVID<ch>:BEIDou:NMESsage:CNAV:EPHemeris:ADELta.....	531
[:SOURce<hw>]:BB:GNSS:SVID<ch>:GPS:NMESsage:CNAV:EPHemeris:ADELta: UNSCaled.....	531
[:SOURce<hw>]:BB:GNSS:SVID<ch>:GPS:NMESsage:CNAV:EPHemeris:ADELta.....	531
[:SOURce<hw>]:BB:GNSS:SVID<ch>:GLONass:NMESsage:NAV:EPHemeris:TINterval?....	532
[:SOURce<hw>]:BB:GNSS:SVID<ch>:GLONass:NMESsage:NAV:EPHemeris:TOE?.....	532
[:SOURce<hw>]:BB:GNSS:SVID<ch>:GLONass:NMESsage:NAV:EPHemeris:TINdex: UNSCaled.....	532
[:SOURce<hw>]:BB:GNSS:SVID<ch>:GLONass:NMESsage:NAV:EPHemeris:TINdex.....	532
[:SOURce<hw>]:BB:GNSS:SVID<ch>:SBAS:NMESsage:NAV:EPHemeris:ZN:UNSCaled.....	532
[:SOURce<hw>]:BB:GNSS:SVID<ch>:SBAS:NMESsage:NAV:EPHemeris:ZN.....	532
[:SOURce<hw>]:BB:GNSS:SVID<ch>:SBAS:NMESsage:NAV:EPHemeris:YN:UNSCaled.....	532
[:SOURce<hw>]:BB:GNSS:SVID<ch>:SBAS:NMESsage:NAV:EPHemeris:YN.....	532
[:SOURce<hw>]:BB:GNSS:SVID<ch>:SBAS:NMESsage:NAV:EPHemeris:YN:UNSCaled.....	532
[:SOURce<hw>]:BB:GNSS:SVID<ch>:SBAS:NMESsage:NAV:EPHemeris:YN.....	532
[:SOURce<hw>]:BB:GNSS:SVID<ch>:GLONass:NMESsage:NAV:EPHemeris:ZN: UNSCaled.....	532
[:SOURce<hw>]:BB:GNSS:SVID<ch>:GLONass:NMESsage:NAV:EPHemeris:ZN.....	533
[:SOURce<hw>]:BB:GNSS:SVID<ch>:GLONass:NMESsage:NAV:EPHemeris:YN: UNSCaled.....	533
[:SOURce<hw>]:BB:GNSS:SVID<ch>:GLONass:NMESsage:NAV:EPHemeris:YN.....	533
[:SOURce<hw>]:BB:GNSS:SVID<ch>:GLONass:NMESsage:NAV:EPHemeris:YN: UNSCaled.....	533
[:SOURce<hw>]:BB:GNSS:SVID<ch>:GLONass:NMESsage:NAV:EPHemeris:YN.....	533
[:SOURce<hw>]:BB:GNSS:SVID<ch>:GLONass:NMESsage:NAV:EPHemeris:YN:UNSCaled... 533	533
[:SOURce<hw>]:BB:GNSS:SVID<ch>:SBAS:NMESsage:NAV:EPHemeris:ZDN.....	533
[:SOURce<hw>]:BB:GNSS:SVID<ch>:SBAS:NMESsage:NAV:EPHemeris:ZDN.....	533
[:SOURce<hw>]:BB:GNSS:SVID<ch>:SBAS:NMESsage:NAV:EPHemeris:YDN:UNSCaled... 533	533
[:SOURce<hw>]:BB:GNSS:SVID<ch>:SBAS:NMESsage:NAV:EPHemeris:YDN.....	533
[:SOURce<hw>]:BB:GNSS:SVID<ch>:SBAS:NMESsage:NAV:EPHemeris:YDN:UNSCaled... 533	533
[:SOURce<hw>]:BB:GNSS:SVID<ch>:SBAS:NMESsage:NAV:EPHemeris:YDN.....	533
[:SOURce<hw>]:BB:GNSS:SVID<ch>:GLONass:NMESsage:NAV:EPHemeris:ZDN: UNSCaled.....	533
[:SOURce<hw>]:BB:GNSS:SVID<ch>:GLONass:NMESsage:NAV:EPHemeris:ZDN.....	533
[:SOURce<hw>]:BB:GNSS:SVID<ch>:GLONass:NMESsage:NAV:EPHemeris:YDN: UNSCaled.....	533
[:SOURce<hw>]:BB:GNSS:SVID<ch>:GLONass:NMESsage:NAV:EPHemeris:YDN.....	533
[:SOURce<hw>]:BB:GNSS:SVID<ch>:GLONass:NMESsage:NAV:EPHemeris:YDN: UNSCaled.....	533
[:SOURce<hw>]:BB:GNSS:SVID<ch>:GLONass:NMESsage:NAV:EPHemeris:YDN.....	533
[:SOURce<hw>]:BB:GNSS:SVID<ch>:GLONass:NMESsage:NAV:EPHemeris:YDN:UNSCaled... 533	533
[:SOURce<hw>]:BB:GNSS:SVID<ch>:SBAS:NMESsage:NAV:EPHemeris:ZDDN: UNSCaled.....	534
[:SOURce<hw>]:BB:GNSS:SVID<ch>:SBAS:NMESsage:NAV:EPHemeris:ZDDN.....	534
[:SOURce<hw>]:BB:GNSS:SVID<ch>:SBAS:NMESsage:NAV:EPHemeris:YDDN: UNSCaled.....	534
[:SOURce<hw>]:BB:GNSS:SVID<ch>:SBAS:NMESsage:NAV:EPHemeris:YDDN.....	534
[:SOURce<hw>]:BB:GNSS:SVID<ch>:SBAS:NMESsage:NAV:EPHemeris:YDDN: UNSCaled.....	534
[:SOURce<hw>]:BB:GNSS:SVID<ch>:SBAS:NMESsage:NAV:EPHemeris:YDDN.....	534

Navigation message commands

[:SOURce<hw>]:BB:GNSS:SVID<ch>:SBAS:NMESsage:NAV:EPHemeris:XDDN.....	534
[:SOURce<hw>]:BB:GNSS:SVID<ch>:GLONass:NMESsage:NAV:EPHemeris:ZDDN: UNSCaled.....	534
[:SOURce<hw>]:BB:GNSS:SVID<ch>:GLONass:NMESsage:NAV:EPHemeris:ZDDN.....	534
[:SOURce<hw>]:BB:GNSS:SVID<ch>:GLONass:NMESsage:NAV:EPHemeris:YDDN: UNSCaled.....	534
[:SOURce<hw>]:BB:GNSS:SVID<ch>:GLONass:NMESsage:NAV:EPHemeris:YDDN.....	534
[:SOURce<hw>]:BB:GNSS:SVID<ch>:GLONass:NMESsage:NAV:EPHemeris:XDDN: UNSCaled.....	534
[:SOURce<hw>]:BB:GNSS:SVID<ch>:GLONass:NMESsage:NAV:EPHemeris:XDDN.....	534
[:SOURce<hw>]:BB:GNSS:SVID<ch>:NAVic:NMESsage:NAV:EPHemeris:CUC:UNSCaled..	534
[:SOURce<hw>]:BB:GNSS:SVID<ch>:NAVic:NMESsage:NAV:EPHemeris:CUC.....	534
[:SOURce<hw>]:BB:GNSS:SVID<ch>:QZSS:NMESsage:CNAV:EPHemeris:CUC: UNSCaled.....	534
[:SOURce<hw>]:BB:GNSS:SVID<ch>:QZSS:NMESsage:CNAV:EPHemeris:CUC.....	534
[:SOURce<hw>]:BB:GNSS:SVID<ch>:QZSS:NMESsage:NAV:EPHemeris:CUC:UNSCaled..	534
[:SOURce<hw>]:BB:GNSS:SVID<ch>:QZSS:NMESsage:NAV:EPHemeris:CUC.....	534
[:SOURce<hw>]:BB:GNSS:SVID<ch>:GALileo:NMESsage:FNAV:EPHemeris:CUC: UNSCaled.....	534
[:SOURce<hw>]:BB:GNSS:SVID<ch>:GALileo:NMESsage:FNAV:EPHemeris:CUC.....	534
[:SOURce<hw>]:BB:GNSS:SVID<ch>:GALileo:NMESsage:INAV:EPHemeris:CUC: UNSCaled.....	534
[:SOURce<hw>]:BB:GNSS:SVID<ch>:GALileo:NMESsage:INAV:EPHemeris:CUC.....	535
[:SOURce<hw>]:BB:GNSS:SVID<ch>:BEIDou:NMESsage:CNAV:EPHemeris:CUC: UNSCaled.....	535
[:SOURce<hw>]:BB:GNSS:SVID<ch>:BEIDou:NMESsage:CNAV:EPHemeris:CUC.....	535
[:SOURce<hw>]:BB:GNSS:SVID<ch>:BEIDou:NMESsage:DNAV:EPHemeris:CUC: UNSCaled.....	535
[:SOURce<hw>]:BB:GNSS:SVID<ch>:BEIDou:NMESsage:DNAV:EPHemeris:CUC.....	535
[:SOURce<hw>]:BB:GNSS:SVID<ch>:GPS:NMESsage:CNAV:EPHemeris:CUC:UNSCaled..	535
[:SOURce<hw>]:BB:GNSS:SVID<ch>:GPS:NMESsage:CNAV:EPHemeris:CUC.....	535
[:SOURce<hw>]:BB:GNSS:SVID<ch>:GPS:NMESsage:LNAV:EPHemeris:CUC:UNSCaled..	535
[:SOURce<hw>]:BB:GNSS:SVID<ch>:GPS:NMESsage:LNAV:EPHemeris:CUC.....	535
[:SOURce<hw>]:BB:GNSS:SVID<ch>:NAVic:NMESsage:NAV:EPHemeris:CUS:UNSCaled...	535
[:SOURce<hw>]:BB:GNSS:SVID<ch>:NAVic:NMESsage:NAV:EPHemeris:CUS.....	535
[:SOURce<hw>]:BB:GNSS:SVID<ch>:QZSS:NMESsage:CNAV:EPHemeris:CUS: UNSCaled.....	535
[:SOURce<hw>]:BB:GNSS:SVID<ch>:QZSS:NMESsage:CNAV:EPHemeris:CUS.....	535
[:SOURce<hw>]:BB:GNSS:SVID<ch>:QZSS:NMESsage:NAV:EPHemeris:CUS:UNSCaled..	535
[:SOURce<hw>]:BB:GNSS:SVID<ch>:QZSS:NMESsage:NAV:EPHemeris:CUS.....	535
[:SOURce<hw>]:BB:GNSS:SVID<ch>:GALileo:NMESsage:FNAV:EPHemeris:CUS: UNSCaled.....	535
[:SOURce<hw>]:BB:GNSS:SVID<ch>:GALileo:NMESsage:FNAV:EPHemeris:CUS.....	535
[:SOURce<hw>]:BB:GNSS:SVID<ch>:GALileo:NMESsage:INAV:EPHemeris:CUS: UNSCaled.....	535
[:SOURce<hw>]:BB:GNSS:SVID<ch>:GALileo:NMESsage:INAV:EPHemeris:CUS.....	535
[:SOURce<hw>]:BB:GNSS:SVID<ch>:BEIDou:NMESsage:CNAV:EPHemeris:CUS: UNSCaled.....	535
[:SOURce<hw>]:BB:GNSS:SVID<ch>:BEIDou:NMESsage:CNAV:EPHemeris:CUS.....	535
[:SOURce<hw>]:BB:GNSS:SVID<ch>:BEIDou:NMESsage:DNAV:EPHemeris:CUS.....	536

Navigation message commands

[:SOURCE<hw>]:BB:GNSS:SVID<ch>:BEIDou:NMESsage:DNAV:EPHemeris:CUS: UNSCaled.....	536
[:SOURCE<hw>]:BB:GNSS:SVID<ch>:GPS:NMESsage:CNAV:EPHemeris:CUS:UNSCaled..	536
[:SOURCE<hw>]:BB:GNSS:SVID<ch>:GPS:NMESsage:CNAV:EPHemeris:CUS.....	536
[:SOURCE<hw>]:BB:GNSS:SVID<ch>:GPS:NMESsage:LNAV:EPHemeris:CUS:UNSCaled...	536
[:SOURCE<hw>]:BB:GNSS:SVID<ch>:GPS:NMESsage:LNAV:EPHemeris:CUS.....	536
[:SOURCE<hw>]:BB:GNSS:SVID<ch>:NAVic:NMESsage:NAV:EPHemeris:CRC:UNSCaled..	536
[:SOURCE<hw>]:BB:GNSS:SVID<ch>:NAVic:NMESsage:NAV:EPHemeris:CRC.....	536
[:SOURCE<hw>]:BB:GNSS:SVID<ch>:QZSS:NMESsage:CNAV:EPHemeris:CRC: UNSCaled.....	536
[:SOURCE<hw>]:BB:GNSS:SVID<ch>:QZSS:NMESsage:CNAV:EPHemeris:CRC.....	536
[:SOURCE<hw>]:BB:GNSS:SVID<ch>:QZSS:NMESsage:NAV:EPHemeris:CRC:UNSCaled..	536
[:SOURCE<hw>]:BB:GNSS:SVID<ch>:QZSS:NMESsage:NAV:EPHemeris:CRC.....	536
[:SOURCE<hw>]:BB:GNSS:SVID<ch>:GALileo:NMESsage:FNAV:EPHemeris:CRC: UNSCaled.....	536
[:SOURCE<hw>]:BB:GNSS:SVID<ch>:GALileo:NMESsage:FNAV:EPHemeris:CRC.....	536
[:SOURCE<hw>]:BB:GNSS:SVID<ch>:GALileo:NMESsage:INAV:EPHemeris:CRC: UNSCaled.....	536
[:SOURCE<hw>]:BB:GNSS:SVID<ch>:GALileo:NMESsage:INAV:EPHemeris:CRC.....	536
[:SOURCE<hw>]:BB:GNSS:SVID<ch>:BEIDou:NMESsage:CNAV:EPHemeris:CRC: UNSCaled.....	536
[:SOURCE<hw>]:BB:GNSS:SVID<ch>:BEIDou:NMESsage:CNAV:EPHemeris:CRC.....	536
[:SOURCE<hw>]:BB:GNSS:SVID<ch>:BEIDou:NMESsage:DNAV:EPHemeris:CRC: UNSCaled.....	536
[:SOURCE<hw>]:BB:GNSS:SVID<ch>:BEIDou:NMESsage:DNAV:EPHemeris:CRC.....	536
[:SOURCE<hw>]:BB:GNSS:SVID<ch>:GPS:NMESsage:CNAV:EPHemeris:CRC:UNSCaled..	536
[:SOURCE<hw>]:BB:GNSS:SVID<ch>:GPS:NMESsage:CNAV:EPHemeris:CRC.....	537
[:SOURCE<hw>]:BB:GNSS:SVID<ch>:GPS:NMESsage:LNAV:EPHemeris:CRC:UNSCaled..	537
[:SOURCE<hw>]:BB:GNSS:SVID<ch>:GPS:NMESsage:LNAV:EPHemeris:CRC.....	537
[:SOURCE<hw>]:BB:GNSS:SVID<ch>:NAVic:NMESsage:NAV:EPHemeris:CRS:UNSCaled...	537
[:SOURCE<hw>]:BB:GNSS:SVID<ch>:NAVic:NMESsage:NAV:EPHemeris:CRS.....	537
[:SOURCE<hw>]:BB:GNSS:SVID<ch>:QZSS:NMESsage:CNAV:EPHemeris:CRS: UNSCaled.....	537
[:SOURCE<hw>]:BB:GNSS:SVID<ch>:QZSS:NMESsage:CNAV:EPHemeris:CRS.....	537
[:SOURCE<hw>]:BB:GNSS:SVID<ch>:QZSS:NMESsage:NAV:EPHemeris:CRS:UNSCaled..	537
[:SOURCE<hw>]:BB:GNSS:SVID<ch>:QZSS:NMESsage:NAV:EPHemeris:CRS.....	537
[:SOURCE<hw>]:BB:GNSS:SVID<ch>:GALileo:NMESsage:FNAV:EPHemeris:CRS: UNSCaled.....	537
[:SOURCE<hw>]:BB:GNSS:SVID<ch>:GALileo:NMESsage:FNAV:EPHemeris:CRS.....	537
[:SOURCE<hw>]:BB:GNSS:SVID<ch>:GALileo:NMESsage:INAV:EPHemeris:CRS: UNSCaled.....	537
[:SOURCE<hw>]:BB:GNSS:SVID<ch>:GALileo:NMESsage:INAV:EPHemeris:CRS.....	537
[:SOURCE<hw>]:BB:GNSS:SVID<ch>:BEIDou:NMESsage:CNAV:EPHemeris:CRS: UNSCaled.....	537
[:SOURCE<hw>]:BB:GNSS:SVID<ch>:BEIDou:NMESsage:CNAV:EPHemeris:CRS.....	537
[:SOURCE<hw>]:BB:GNSS:SVID<ch>:BEIDou:NMESsage:DNAV:EPHemeris:CRS: UNSCaled.....	537
[:SOURCE<hw>]:BB:GNSS:SVID<ch>:BEIDou:NMESsage:DNAV:EPHemeris:CRS.....	537
[:SOURCE<hw>]:BB:GNSS:SVID<ch>:GPS:NMESsage:CNAV:EPHemeris:CRS:UNSCaled..	537
[:SOURCE<hw>]:BB:GNSS:SVID<ch>:GPS:NMESsage:CNAV:EPHemeris:CRS.....	537

Navigation message commands

[:SOURce<hw>]:BB:GNSS:SVID<ch>:GPS:NMESsage:LNAV:EPHemeris:CRS:UNSCaled... 538

[:SOURce<hw>]:BB:GNSS:SVID<ch>:GPS:NMESsage:LNAV:EPHemeris:CRS..... 538

[:SOURce<hw>]:BB:GNSS:SVID<ch>:NAVic:NMESsage:NAV:EPHemeris:CIC:UNSCaled... 538

[:SOURce<hw>]:BB:GNSS:SVID<ch>:NAVic:NMESsage:NAV:EPHemeris:CIC..... 538

[:SOURce<hw>]:BB:GNSS:SVID<ch>:QZSS:NMESsage:CNAV:EPHemeris:CIC:
UNSCaled..... 538

[:SOURce<hw>]:BB:GNSS:SVID<ch>:QZSS:NMESsage:CNAV:EPHemeris:CIC..... 538

[:SOURce<hw>]:BB:GNSS:SVID<ch>:QZSS:NMESsage:NAV:EPHemeris:CIC:UNSCaled... 538

[:SOURce<hw>]:BB:GNSS:SVID<ch>:QZSS:NMESsage:NAV:EPHemeris:CIC..... 538

[:SOURce<hw>]:BB:GNSS:SVID<ch>:GALileo:NMESsage:FNAV:EPHemeris:CIC:
UNSCaled..... 538

[:SOURce<hw>]:BB:GNSS:SVID<ch>:GALileo:NMESsage:FNAV:EPHemeris:CIC..... 538

[:SOURce<hw>]:BB:GNSS:SVID<ch>:GALileo:NMESsage:INAV:EPHemeris:CIC:
UNSCaled..... 538

[:SOURce<hw>]:BB:GNSS:SVID<ch>:GALileo:NMESsage:INAV:EPHemeris:CIC..... 538

[:SOURce<hw>]:BB:GNSS:SVID<ch>:BEIDou:NMESsage:CNAV:EPHemeris:CIC:
UNSCaled..... 538

[:SOURce<hw>]:BB:GNSS:SVID<ch>:BEIDou:NMESsage:CNAV:EPHemeris:CIC..... 538

[:SOURce<hw>]:BB:GNSS:SVID<ch>:BEIDou:NMESsage:DNAV:EPHemeris:CIC:
UNSCaled..... 538

[:SOURce<hw>]:BB:GNSS:SVID<ch>:BEIDou:NMESsage:DNAV:EPHemeris:CIC..... 538

[:SOURce<hw>]:BB:GNSS:SVID<ch>:GPS:NMESsage:CNAV:EPHemeris:CIC:UNSCaled... 538

[:SOURce<hw>]:BB:GNSS:SVID<ch>:GPS:NMESsage:CNAV:EPHemeris:CIC..... 538

[:SOURce<hw>]:BB:GNSS:SVID<ch>:GPS:NMESsage:LNAV:EPHemeris:CIC:UNSCaled... 538

[:SOURce<hw>]:BB:GNSS:SVID<ch>:GPS:NMESsage:LNAV:EPHemeris:CIC..... 538

[:SOURce<hw>]:BB:GNSS:SVID<ch>:NAVic:NMESsage:NAV:EPHemeris:CIS:UNSCaled... 539

[:SOURce<hw>]:BB:GNSS:SVID<ch>:NAVic:NMESsage:NAV:EPHemeris:CIS..... 539

[:SOURce<hw>]:BB:GNSS:SVID<ch>:QZSS:NMESsage:CNAV:EPHemeris:CIS:UNSCaled... 539

[:SOURce<hw>]:BB:GNSS:SVID<ch>:QZSS:NMESsage:CNAV:EPHemeris:CIS..... 539

[:SOURce<hw>]:BB:GNSS:SVID<ch>:QZSS:NMESsage:NAV:EPHemeris:CIS:UNSCaled... 539

[:SOURce<hw>]:BB:GNSS:SVID<ch>:QZSS:NMESsage:NAV:EPHemeris:CIS..... 539

[:SOURce<hw>]:BB:GNSS:SVID<ch>:GALileo:NMESsage:FNAV:EPHemeris:CIS:
UNSCaled..... 539

[:SOURce<hw>]:BB:GNSS:SVID<ch>:GALileo:NMESsage:FNAV:EPHemeris:CIS..... 539

[:SOURce<hw>]:BB:GNSS:SVID<ch>:GALileo:NMESsage:INAV:EPHemeris:CIS:
UNSCaled..... 539

[:SOURce<hw>]:BB:GNSS:SVID<ch>:GALileo:NMESsage:INAV:EPHemeris:CIS..... 539

[:SOURce<hw>]:BB:GNSS:SVID<ch>:BEIDou:NMESsage:CNAV:EPHemeris:CIS:
UNSCaled..... 539

[:SOURce<hw>]:BB:GNSS:SVID<ch>:BEIDou:NMESsage:CNAV:EPHemeris:CIS..... 539

[:SOURce<hw>]:BB:GNSS:SVID<ch>:BEIDou:NMESsage:DNAV:EPHemeris:CIS:
UNSCaled..... 539

[:SOURce<hw>]:BB:GNSS:SVID<ch>:BEIDou:NMESsage:DNAV:EPHemeris:CIS..... 539

[:SOURce<hw>]:BB:GNSS:SVID<ch>:GPS:NMESsage:CNAV:EPHemeris:CIS:UNSCaled... 539

[:SOURce<hw>]:BB:GNSS:SVID<ch>:GPS:NMESsage:CNAV:EPHemeris:CIS..... 539

[:SOURce<hw>]:BB:GNSS:SVID<ch>:GPS:NMESsage:LNAV:EPHemeris:CIS:UNSCaled... 539

[:SOURce<hw>]:BB:GNSS:SVID<ch>:GPS:NMESsage:LNAV:EPHemeris:CIS..... 539

[:SOURce<hw>]:BB:GNSS:SVID<ch>:QZSS:NMESsage:NAV:EPHemeris:IODC..... 540

[:SOURce<hw>]:BB:GNSS:SVID<ch>:BEIDou:NMESsage:DNAV:EPHemeris:IODC..... 540

[:SOURce<hw>]:BB:GNSS:SVID<ch>:GPS:NMESsage:LNAV:EPHemeris:IODC..... 540

Navigation message commands

[:SOURce<hw>]:BB:GNSS:SVID<ch>:NAVic:NMESsage:NAV:CCORrection:TOC: UNSCaled.....	540
[:SOURce<hw>]:BB:GNSS:SVID<ch>:NAVic:NMESsage:NAV:CCORrection:TOC.....	540
[:SOURce<hw>]:BB:GNSS:SVID<ch>:QZSS:NMESsage:CNAV:CCORrection:TOC: UNSCaled.....	540
[:SOURce<hw>]:BB:GNSS:SVID<ch>:QZSS:NMESsage:CNAV:CCORrection:TOC.....	540
[:SOURce<hw>]:BB:GNSS:SVID<ch>:QZSS:NMESsage:NAV:CCORrection:TOC: UNSCaled.....	540
[:SOURce<hw>]:BB:GNSS:SVID<ch>:QZSS:NMESsage:NAV:CCORrection:TOC.....	540
[:SOURce<hw>]:BB:GNSS:SVID<ch>:GALileo:NMESsage:FNAV:CCORrection:TOC: UNSCaled.....	540
[:SOURce<hw>]:BB:GNSS:SVID<ch>:GALileo:NMESsage:FNAV:CCORrection:TOC.....	540
[:SOURce<hw>]:BB:GNSS:SVID<ch>:GALileo:NMESsage:INAV:CCORrection:TOC: UNSCaled.....	540
[:SOURce<hw>]:BB:GNSS:SVID<ch>:GALileo:NMESsage:INAV:CCORrection:TOC.....	540
[:SOURce<hw>]:BB:GNSS:SVID<ch>:BEIDou:NMESsage:CNAV:CCORrection:TOC: UNSCaled.....	540
[:SOURce<hw>]:BB:GNSS:SVID<ch>:BEIDou:NMESsage:CNAV:CCORrection:TOC.....	540
[:SOURce<hw>]:BB:GNSS:SVID<ch>:BEIDou:NMESsage:DNAV:CCORrection:TOC: UNSCaled.....	540
[:SOURce<hw>]:BB:GNSS:SVID<ch>:BEIDou:NMESsage:DNAV:CCORrection:TOC.....	540
[:SOURce<hw>]:BB:GNSS:SVID<ch>:GPS:NMESsage:CNAV:CCORrection:TOC: UNSCaled.....	540
[:SOURce<hw>]:BB:GNSS:SVID<ch>:GPS:NMESsage:CNAV:CCORrection:TOC.....	540
[:SOURce<hw>]:BB:GNSS:SVID<ch>:GPS:NMESsage:LNAV:CCORrection:TOC: UNSCaled.....	541
[:SOURce<hw>]:BB:GNSS:SVID<ch>:GPS:NMESsage:LNAV:CCORrection:TOC.....	541
[:SOURce<hw>]:BB:GNSS:SVID<ch>:SBAS:NMESsage:NAV:CCORrection:AF<s2us0>.....	541
[:SOURce<hw>]:BB:GNSS:SVID<ch>:SBAS:NMESsage:NAV:CCORrection: AF<s2us0>:UNSCaled.....	541
[:SOURce<hw>]:BB:GNSS:SVID<ch>:NAVic:NMESsage:NAV:CCORrection: AF<s2us0>:UNSCaled.....	541
[:SOURce<hw>]:BB:GNSS:SVID<ch>:NAVic:NMESsage:NAV:CCORrection:AF<s2us0>.....	541
[:SOURce<hw>]:BB:GNSS:SVID<ch>:QZSS:NMESsage:CNAV:CCORrection: AF<s2us0>:UNSCaled.....	541
[:SOURce<hw>]:BB:GNSS:SVID<ch>:QZSS:NMESsage:CNAV:CCORrection:AF<s2us0>.....	541
[:SOURce<hw>]:BB:GNSS:SVID<ch>:QZSS:NMESsage:NAV:CCORrection: AF<s2us0>:UNSCaled.....	541
[:SOURce<hw>]:BB:GNSS:SVID<ch>:QZSS:NMESsage:NAV:CCORrection:AF<s2us0>.....	541
[:SOURce<hw>]:BB:GNSS:SVID<ch>:GALileo:NMESsage:FNAV:CCORrection: AF<s2us0>:UNSCaled.....	541
[:SOURce<hw>]:BB:GNSS:SVID<ch>:GALileo:NMESsage:FNAV:CCORrection: AF<s2us0>.....	541
[:SOURce<hw>]:BB:GNSS:SVID<ch>:GALileo:NMESsage:INAV:CCORrection: AF<s2us0>:UNSCaled.....	541
[:SOURce<hw>]:BB:GNSS:SVID<ch>:GALileo:NMESsage:INAV:CCORrection:AF<s2us0>.....	541
[:SOURce<hw>]:BB:GNSS:SVID<ch>:BEIDou:NMESsage:CNAV:CCORrection: AF<s2us0>:UNSCaled.....	541
[:SOURce<hw>]:BB:GNSS:SVID<ch>:BEIDou:NMESsage:CNAV:CCORrection: AF<s2us0>.....	541

Navigation message commands

[:SOURce<hw>]:BB:GNSS:SVID<ch>:BEIDou:NMEssage:DNAV:CCORrection: AF<s2us0>:UNSCaled.....	541
[:SOURce<hw>]:BB:GNSS:SVID<ch>:BEIDou:NMEssage:DNAV:CCORrection:AF<s2us0>.....	541
[:SOURce<hw>]:BB:GNSS:SVID<ch>:GPS:NMEssage:CNAV:CCORrection: AF<s2us0>:UNSCaled.....	541
[:SOURce<hw>]:BB:GNSS:SVID<ch>:GPS:NMEssage:CNAV:CCORrection:AF<s2us0>.....	541
[:SOURce<hw>]:BB:GNSS:SVID<ch>:GPS:NMEssage:LNAV:CCORrection: AF<s2us0>:UNSCaled.....	542
[:SOURce<hw>]:BB:GNSS:SVID<ch>:GPS:NMEssage:LNAV:CCORrection:AF<s2us0>.....	542
[:SOURce<hw>]:BB:GNSS:SVID<ch>:NAVic:NMEssage:NAV:CCORrection:TGD: UNSCaled.....	542
[:SOURce<hw>]:BB:GNSS:SVID<ch>:NAVic:NMEssage:NAV:CCORrection:TGD.....	542
[:SOURce<hw>]:BB:GNSS:SVID<ch>:QZSS:NMEssage:CNAV:CCORrection:TGD: UNSCaled.....	542
[:SOURce<hw>]:BB:GNSS:SVID<ch>:QZSS:NMEssage:CNAV:CCORrection:TGD.....	542
[:SOURce<hw>]:BB:GNSS:SVID<ch>:QZSS:NMEssage:NAV:CCORrection:TGD: UNSCaled.....	542
[:SOURce<hw>]:BB:GNSS:SVID<ch>:QZSS:NMEssage:NAV:CCORrection:TGD.....	542
[:SOURce<hw>]:BB:GNSS:SVID<ch>:BEIDou:NMEssage:CNAV:CCORrection:TGD: UNSCaled.....	542
[:SOURce<hw>]:BB:GNSS:SVID<ch>:BEIDou:NMEssage:CNAV:CCORrection:TGD.....	542
[:SOURce<hw>]:BB:GNSS:SVID<ch>:BEIDou:NMEssage:DNAV:CCORrection: TGD<s2us>:UNSCaled.....	542
[:SOURce<hw>]:BB:GNSS:SVID<ch>:BEIDou:NMEssage:DNAV:CCORrection: TGD<s2us>.....	542
[:SOURce<hw>]:BB:GNSS:SVID<ch>:GPS:NMEssage:CNAV:CCORrection:TGD: UNSCaled.....	542
[:SOURce<hw>]:BB:GNSS:SVID<ch>:GPS:NMEssage:CNAV:CCORrection:TGD.....	542
[:SOURce<hw>]:BB:GNSS:SVID<ch>:GPS:NMEssage:LNAV:CCORrection:TGD: UNSCaled.....	542
[:SOURce<hw>]:BB:GNSS:SVID<ch>:GPS:NMEssage:LNAV:CCORrection:TGD.....	542
[:SOURce<hw>]:BB:GNSS:SVID<ch>:QZSS:NMEssage:CNAV:CCORrection:ISC:L5Q: UNSCaled.....	543
[:SOURce<hw>]:BB:GNSS:SVID<ch>:QZSS:NMEssage:CNAV:CCORrection:ISC:L5Q.....	543
[:SOURce<hw>]:BB:GNSS:SVID<ch>:QZSS:NMEssage:CNAV:CCORrection:ISC:L5I: UNSCaled.....	543
[:SOURce<hw>]:BB:GNSS:SVID<ch>:QZSS:NMEssage:CNAV:CCORrection:ISC:L5I.....	543
[:SOURce<hw>]:BB:GNSS:SVID<ch>:QZSS:NMEssage:CNAV:CCORrection:ISC:L2C: UNSCaled.....	543
[:SOURce<hw>]:BB:GNSS:SVID<ch>:QZSS:NMEssage:CNAV:CCORrection:ISC:L2C.....	543
[:SOURce<hw>]:BB:GNSS:SVID<ch>:QZSS:NMEssage:CNAV:CCORrection:ISC:L1CA: UNSCaled.....	543
[:SOURce<hw>]:BB:GNSS:SVID<ch>:QZSS:NMEssage:CNAV:CCORrection:ISC:L1CA.....	543
[:SOURce<hw>]:BB:GNSS:SVID<ch>:GPS:NMEssage:CNAV:CCORrection:ISC:L5Q: UNSCaled.....	543
[:SOURce<hw>]:BB:GNSS:SVID<ch>:GPS:NMEssage:CNAV:CCORrection:ISC:L5Q.....	543
[:SOURce<hw>]:BB:GNSS:SVID<ch>:GPS:NMEssage:CNAV:CCORrection:ISC:L5I: UNSCaled.....	543
[:SOURce<hw>]:BB:GNSS:SVID<ch>:GPS:NMEssage:CNAV:CCORrection:ISC:L5I.....	543

Navigation message commands

[:SOURce<hw>]:BB:GNSS:SVID<ch>:GPS:NMESSage:CNAV:CCORrection:ISC:L2C: UNSCaled.....	543
[:SOURce<hw>]:BB:GNSS:SVID<ch>:GPS:NMESSage:CNAV:CCORrection:ISC:L2C.....	543
[:SOURce<hw>]:BB:GNSS:SVID<ch>:GPS:NMESSage:CNAV:CCORrection:ISC:L1CA: UNSCaled.....	543
[:SOURce<hw>]:BB:GNSS:SVID<ch>:GPS:NMESSage:CNAV:CCORrection:ISC:L1CA.....	543
[:SOURce<hw>]:BB:GNSS:SVID<ch>:GALileo:NMESSage:FNAV:CCORrection:BGDA: UNSCaled.....	543
[:SOURce<hw>]:BB:GNSS:SVID<ch>:GALileo:NMESSage:FNAV:CCORrection:BGDA.....	543
[:SOURce<hw>]:BB:GNSS:SVID<ch>:GALileo:NMESSage:INAV:CCORrection:BGDB: UNSCaled.....	543
[:SOURce<hw>]:BB:GNSS:SVID<ch>:GALileo:NMESSage:INAV:CCORrection:BGDB.....	543
[:SOURce<hw>]:BB:GNSS:SVID<ch>:GALileo:NMESSage:INAV:CCORrection:BGDA: UNSCaled.....	544
[:SOURce<hw>]:BB:GNSS:SVID<ch>:GALileo:NMESSage:INAV:CCORrection:BGDA.....	544
[:SOURce<hw>]:BB:GNSS:SVID<ch>:GLONass:NMESSage:NAV:CCORrection:TAUN: UNSCaled.....	544
[:SOURce<hw>]:BB:GNSS:SVID<ch>:GLONass:NMESSage:NAV:CCORrection:TAUN.....	544
[:SOURce<hw>]:BB:GNSS:SVID<ch>:GLONass:NMESSage:NAV:CCORrection:GAMN: UNSCaled.....	544
[:SOURce<hw>]:BB:GNSS:SVID<ch>:GLONass:NMESSage:NAV:CCORrection:GAMN.....	544
[:SOURce<hw>]:BB:GNSS:SVID<ch>:GLONass:NMESSage:NAV:CCORrection:DTAU: UNSCaled.....	544
[:SOURce<hw>]:BB:GNSS:SVID<ch>:GLONass:NMESSage:NAV:CCORrection:DTAU.....	544
[:SOURce<hw>]:BB:GNSS:SVID<ch>:QZSS:NMESSage:CNAV:EPHemeris:ALERT.....	545
[:SOURce<hw>]:BB:GNSS:SVID<ch>:BEIDou:NMESSage:CNAV:EPHemeris:ALERT.....	545
[:SOURce<hw>]:BB:GNSS:SVID<ch>:GPS:NMESSage:CNAV:EPHemeris:ALERT.....	545
[:SOURce<hw>]:BB:GNSS:SVID<ch>:QZSS:NMESSage:CNAV:EPHemeris:L5Health.....	545
[:SOURce<hw>]:BB:GNSS:SVID<ch>:QZSS:NMESSage:CNAV:EPHemeris:L2Health.....	545
[:SOURce<hw>]:BB:GNSS:SVID<ch>:QZSS:NMESSage:CNAV:EPHemeris:L1Health.....	545
[:SOURce<hw>]:BB:GNSS:SVID<ch>:GPS:NMESSage:CNAV:EPHemeris:L5Health.....	545
[:SOURce<hw>]:BB:GNSS:SVID<ch>:GPS:NMESSage:CNAV:EPHemeris:L2Health.....	545
[:SOURce<hw>]:BB:GNSS:SVID<ch>:GPS:NMESSage:CNAV:EPHemeris:L1Health.....	545
[:SOURce<hw>]:BB:GNSS:SVID<ch>:QZSS:NMESSage:CNAV:EPHemeris:NED0.....	545
[:SOURce<hw>]:BB:GNSS:SVID<ch>:QZSS:NMESSage:CNAV:EPHemeris:NED1.....	545
[:SOURce<hw>]:BB:GNSS:SVID<ch>:QZSS:NMESSage:CNAV:EPHemeris:NED2.....	545
[:SOURce<hw>]:BB:GNSS:SVID<ch>:GPS:NMESSage:CNAV:EPHemeris:NED0.....	545
[:SOURce<hw>]:BB:GNSS:SVID<ch>:GPS:NMESSage:CNAV:EPHemeris:NED1.....	545
[:SOURce<hw>]:BB:GNSS:SVID<ch>:GPS:NMESSage:CNAV:EPHemeris:NED2.....	545
[:SOURce<hw>]:BB:GNSS:SVID<ch>:GPS:NMESSage:CNAV:EPHemeris:WNOP.....	546
[:SOURce<hw>]:BB:GNSS:SVID<ch>:GPS:NMESSage:CNAV:EPHemeris:TOP:UNSCaled..	546
[:SOURce<hw>]:BB:GNSS:SVID<ch>:GPS:NMESSage:CNAV:EPHemeris:TOP.....	546
[:SOURce<hw>]:BB:GNSS:SVID<ch>:QZSS:NMESSage:CNAV:EPHemeris:ISFLag.....	546
[:SOURce<hw>]:BB:GNSS:SVID<ch>:GPS:NMESSage:CNAV:EPHemeris:ISFLag.....	546
[:SOURce<hw>]:BB:GNSS:SVID<ch>:QZSS:NMESSage:CNAV:EPHemeris:L2CPhasing.....	546
[:SOURce<hw>]:BB:GNSS:SVID<ch>:GPS:NMESSage:CNAV:EPHemeris:L2CPhasing.....	546
[:SOURce<hw>]:BB:GNSS:SVID<ch>:NAVic:NMESSage:NAV:EPHemeris:L5Health.....	547
[:SOURce<hw>]:BB:GNSS:SVID<ch>:NAVic:NMESSage:NAV:EPHemeris:SHEalth.....	547
[:SOURce<hw>]:BB:GNSS:SVID<ch>:QZSS:NMESSage:NAV:EPHemeris:HEALth.....	547
[:SOURce<hw>]:BB:GNSS:SVID<ch>:GLONass:NMESSage:NAV:EPHemeris:HEALth.....	547

Navigation message commands

[:SOURce<hw>]:BB:GNSS:SVID<ch>:BEIDou:NMESsage:DNAV:EPHemeris:HEALth.....	547
[:SOURce<hw>]:BB:GNSS:SVID<ch>:GPS:NMESsage:LNAV:EPHemeris:HEALth.....	547
[:SOURce<hw>]:BB:GNSS:SVID<ch>:SBAS:NMESsage:NAV:EPHemeris:URA.....	547
[:SOURce<hw>]:BB:GNSS:SVID<ch>:NAVic:NMESsage:NAV:EPHemeris:URA.....	547
[:SOURce<hw>]:BB:GNSS:SVID<ch>:QZSS:NMESsage:CNAV:EPHemeris:URA.....	547
[:SOURce<hw>]:BB:GNSS:SVID<ch>:QZSS:NMESsage:NAV:EPHemeris:URA.....	547
[:SOURce<hw>]:BB:GNSS:SVID<ch>:GLONass:NMESsage:NAV:EPHemeris:URA.....	547
[:SOURce<hw>]:BB:GNSS:SVID<ch>:BEIDou:NMESsage:DNAV:EPHemeris:URA.....	548
[:SOURce<hw>]:BB:GNSS:SVID<ch>:GPS:NMESsage:CNAV:EPHemeris:URA.....	548
[:SOURce<hw>]:BB:GNSS:SVID<ch>:GPS:NMESsage:LNAV:EPHemeris:URA.....	548
[:SOURce<hw>]:BB:GNSS:SVID<ch>:GPS:NMESsage:LNAV:EPHemeris:ASFLag.....	548
[:SOURce<hw>]:BB:GNSS:SVID<ch>:QZSS:NMESsage:NAV:EPHemeris:SVConfig.....	548
[:SOURce<hw>]:BB:GNSS:SVID<ch>:GPS:NMESsage:LNAV:EPHemeris:SVConfig.....	548
[:SOURce<hw>]:BB:GNSS:SVID<ch>:QZSS:NMESsage:NAV:EPHemeris:CLTMode.....	548
[:SOURce<hw>]:BB:GNSS:SVID<ch>:GPS:NMESsage:LNAV:EPHemeris:CLTMode.....	548
[:SOURce<hw>]:BB:GNSS:SVID<ch>:QZSS:NMESsage:NAV:EPHemeris:LTPData.....	548
[:SOURce<hw>]:BB:GNSS:SVID<ch>:GPS:NMESsage:LNAV:EPHemeris:LTPData.....	548
[:SOURce<hw>]:BB:GNSS:SVID<ch>:QZSS:NMESsage:NAV:EPHemeris:FIFLag.....	549
[:SOURce<hw>]:BB:GNSS:SVID<ch>:GPS:NMESsage:LNAV:EPHemeris:FIFLag.....	549
[:SOURce<hw>]:BB:GNSS:SVID<ch>:QZSS:NMESsage:NAV:EPHemeris:AODO?.....	549
[:SOURce<hw>]:BB:GNSS:SVID<ch>:GPS:NMESsage:LNAV:EPHemeris:AODO?.....	549
[:SOURce<hw>]:BB:GNSS:SVID<ch>:QZSS:NMESsage:NAV:EPHemeris: SF1Reserved<s2us>?.....	549
[:SOURce<hw>]:BB:GNSS:SVID<ch>:GPS:NMESsage:LNAV:EPHemeris: SF1Reserved<s2us>?.....	549
[:SOURce<hw>]:BB:GNSS:SVID<ch>:GALileo:NMESsage:FNAV:EPHemeris:SISA.....	549
[:SOURce<hw>]:BB:GNSS:SVID<ch>:GALileo:NMESsage:INAV:EPHemeris:SISA.....	549
[:SOURce<hw>]:BB:GNSS:SVID<ch>:GALileo:NMESsage:INAV:E1BDVS.....	550
[:SOURce<hw>]:BB:GNSS:SVID<ch>:GALileo:NMESsage:INAV:E1BHS.....	550
[:SOURce<hw>]:BB:GNSS:SVID<ch>:GALileo:NMESsage:INAV:E5BDVS.....	550
[:SOURce<hw>]:BB:GNSS:SVID<ch>:GALileo:NMESsage:INAV:E5BHS.....	550
[:SOURce<hw>]:BB:GNSS:SVID<ch>:GALileo:NMESsage:INAV:EPHemeris:SAR:MODE.....	550
[:SOURce<hw>]:BB:GNSS:SVID<ch>:GALileo:NMESsage:INAV:EPHemeris:SAR: RLM<s2us>.....	551
[:SOURce<hw>]:BB:GNSS:SVID<ch>:GALileo:NMESsage:INAV:EPHemeris:SAR:SPARe....	551
[:SOURce<hw>]:BB:GNSS:SVID<ch>:GALileo:NMESsage:FNAV:E5ADVS.....	552
[:SOURce<hw>]:BB:GNSS:SVID<ch>:GALileo:NMESsage:FNAV:E5AHS.....	552
[:SOURce<hw>]:BB:GNSS:SVID<ch>:GLONass:NMESsage:NAV:EPHemeris:SEType.....	552
[:SOURce<hw>]:BB:GNSS:SVID<ch>:GLONass:NMESsage:NAV:EPHemeris:CFM.....	552
[:SOURce<hw>]:BB:GNSS:SVID<ch>:GLONass:NMESsage:NAV:EPHemeris:P.....	552
[:SOURce<hw>]:BB:GNSS:SVID<ch>:GLONass:NMESsage:NAV:EPHemeris:AOEP.....	553
[:SOURce<hw>]:BB:GNSS:SVID<ch>:GLONass:NMESsage:NAV:EPHemeris:TALignment...	553
[:SOURce<hw>]:BB:GNSS:SVID<ch>:GLONass:NMESsage:NAV:CCORrection:EN.....	553
[:SOURce<hw>]:BB:GNSS:SV:SBAS:WAAS:NMESsage:NAV:TIME:CONVersion:UTC: WNOT.....	553
[:SOURce<hw>]:BB:GNSS:SV:SBAS:MSAS:NMESsage:NAV:TIME:CONVersion:UTC: WNOT.....	553
[:SOURce<hw>]:BB:GNSS:SV:SBAS:GAGAN:NMESsage:NAV:TIME:CONVersion:UTC: WNOT.....	553

Navigation message commands

[:SOURce<hw>]:BB:GNSS:SV:SBAS:EGNOS:NMESSage:NAV:TIME:CONVersion:UTC: WNOT.....	553
[:SOURce<hw>]:BB:GNSS:SV:NAVic:NMESSage:NAV:TIME:CONVersion:UTC:WNOT.....	553
[:SOURce<hw>]:BB:GNSS:SV:QZSS:NMESSage:CNAV:TIME:CONVersion:UTC:WNOT.....	553
[:SOURce<hw>]:BB:GNSS:SV:QZSS:NMESSage:NAV:TIME:CONVersion:UTC:WNOT.....	553
[:SOURce<hw>]:BB:GNSS:SV:GALileo:NMESSage:FNAV:TIME:CONVersion:UTC:WNOT.....	554
[:SOURce<hw>]:BB:GNSS:SV:GALileo:NMESSage:INAV:TIME:CONVersion:UTC:WNOT.....	554
[:SOURce<hw>]:BB:GNSS:SV:BEIDou:NMESSage:CNAV:TIME:CONVersion:UTC:WNOT.....	554
[:SOURce<hw>]:BB:GNSS:SV:BEIDou:NMESSage:DNAV:TIME:CONVersion:UTC:WNOT.....	554
[:SOURce<hw>]:BB:GNSS:SV:GPS:NMESSage:CNAV:TIME:CONVersion:UTC:WNOT.....	554
[:SOURce<hw>]:BB:GNSS:SV:GPS:NMESSage:LNAV:TIME:CONVersion:UTC:WNOT.....	554
[:SOURce<hw>]:BB:GNSS:SV:SBAS:WAAS:NMESSage:NAV:TIME:CONVersion:UTC: TOT:UNSCaled.....	554
[:SOURce<hw>]:BB:GNSS:SV:SBAS:WAAS:NMESSage:NAV:TIME:CONVersion:UTC:TOT..	554
[:SOURce<hw>]:BB:GNSS:SV:SBAS:MSAS:NMESSage:NAV:TIME:CONVersion:UTC: TOT:UNSCaled.....	554
[:SOURce<hw>]:BB:GNSS:SV:SBAS:MSAS:NMESSage:NAV:TIME:CONVersion:UTC:TOT..	554
[:SOURce<hw>]:BB:GNSS:SV:SBAS:GAGAN:NMESSage:NAV:TIME:CONVersion:UTC: TOT:UNSCaled.....	554
[:SOURce<hw>]:BB:GNSS:SV:SBAS:GAGAN:NMESSage:NAV:TIME:CONVersion:UTC: TOT.....	554
[:SOURce<hw>]:BB:GNSS:SV:SBAS:EGNOS:NMESSage:NAV:TIME:CONVersion:UTC: TOT:UNSCaled.....	554
[:SOURce<hw>]:BB:GNSS:SV:SBAS:EGNOS:NMESSage:NAV:TIME:CONVersion:UTC: TOT.....	554
[:SOURce<hw>]:BB:GNSS:SV:NAVic:NMESSage:NAV:TIME:CONVersion:UTC:TOT: UNSCaled.....	554
[:SOURce<hw>]:BB:GNSS:SV:NAVic:NMESSage:NAV:TIME:CONVersion:UTC:TOT.....	554
[:SOURce<hw>]:BB:GNSS:SV:QZSS:NMESSage:CNAV:TIME:CONVersion:UTC:TOT: UNSCaled.....	554
[:SOURce<hw>]:BB:GNSS:SV:QZSS:NMESSage:CNAV:TIME:CONVersion:UTC:TOT.....	554
[:SOURce<hw>]:BB:GNSS:SV:QZSS:NMESSage:NAV:TIME:CONVersion:UTC:TOT: UNSCaled.....	554
[:SOURce<hw>]:BB:GNSS:SV:QZSS:NMESSage:NAV:TIME:CONVersion:UTC:TOT.....	554
[:SOURce<hw>]:BB:GNSS:SV:GALileo:NMESSage:FNAV:TIME:CONVersion:UTC:TOT: UNSCaled.....	554
[:SOURce<hw>]:BB:GNSS:SV:GALileo:NMESSage:FNAV:TIME:CONVersion:UTC:TOT.....	555
[:SOURce<hw>]:BB:GNSS:SV:GALileo:NMESSage:INAV:TIME:CONVersion:UTC:TOT: UNSCaled.....	555
[:SOURce<hw>]:BB:GNSS:SV:GALileo:NMESSage:INAV:TIME:CONVersion:UTC:TOT.....	555
[:SOURce<hw>]:BB:GNSS:SV:BEIDou:NMESSage:CNAV:TIME:CONVersion:UTC:TOT: UNSCaled.....	555
[:SOURce<hw>]:BB:GNSS:SV:BEIDou:NMESSage:CNAV:TIME:CONVersion:UTC:TOT.....	555
[:SOURce<hw>]:BB:GNSS:SV:BEIDou:NMESSage:DNAV:TIME:CONVersion:UTC:TOT: UNSCaled.....	555
[:SOURce<hw>]:BB:GNSS:SV:BEIDou:NMESSage:DNAV:TIME:CONVersion:UTC:TOT.....	555
[:SOURce<hw>]:BB:GNSS:SV:GPS:NMESSage:CNAV:TIME:CONVersion:UTC:TOT: UNSCaled.....	555
[:SOURce<hw>]:BB:GNSS:SV:GPS:NMESSage:CNAV:TIME:CONVersion:UTC:TOT.....	555

Navigation message commands

[:SOURCE<hw>]:BB:GNSS:SV:GPS:NMESSage:LNAV:TIME:CONVersion:UTC:TOT: UNSCaled.....	555
[:SOURCE<hw>]:BB:GNSS:SV:GPS:NMESSage:LNAV:TIME:CONVersion:UTC:TOT.....	555
[:SOURCE<hw>]:BB:GNSS:SV:NAVic:NMESSage:NAV:TIME:CONVersion:UTC:ATWO: UNSCaled.....	555
[:SOURCE<hw>]:BB:GNSS:SV:NAVic:NMESSage:NAV:TIME:CONVersion:UTC:ATWO.....	555
[:SOURCE<hw>]:BB:GNSS:SV:QZSS:NMESSage:CNAV:TIME:CONVersion:UTC: ATWO:UNSCaled.....	555
[:SOURCE<hw>]:BB:GNSS:SV:QZSS:NMESSage:CNAV:TIME:CONVersion:UTC:ATWO.....	555
[:SOURCE<hw>]:BB:GNSS:SV:GPS:NMESSage:CNAV:TIME:CONVersion:UTC:ATWO: UNSCaled.....	555
[:SOURCE<hw>]:BB:GNSS:SV:GPS:NMESSage:CNAV:TIME:CONVersion:UTC:ATWO.....	555
[:SOURCE<hw>]:BB:GNSS:SV:SBAS:WAAS:NMESSage:NAV:TIME:CONVersion:UTC: AONE:UNSCaled.....	556
[:SOURCE<hw>]:BB:GNSS:SV:SBAS:WAAS:NMESSage:NAV:TIME:CONVersion:UTC: AONE.....	556
[:SOURCE<hw>]:BB:GNSS:SV:SBAS:MSAS:NMESSage:NAV:TIME:CONVersion:UTC: AONE:UNSCaled.....	556
[:SOURCE<hw>]:BB:GNSS:SV:SBAS:MSAS:NMESSage:NAV:TIME:CONVersion:UTC: AONE.....	556
[:SOURCE<hw>]:BB:GNSS:SV:SBAS:GAGAN:NMESSage:NAV:TIME:CONVersion:UTC: AONE:UNSCaled.....	556
[:SOURCE<hw>]:BB:GNSS:SV:SBAS:GAGAN:NMESSage:NAV:TIME:CONVersion:UTC: AONE.....	556
[:SOURCE<hw>]:BB:GNSS:SV:SBAS:EGNOS:NMESSage:NAV:TIME:CONVersion:UTC: AONE:UNSCaled.....	556
[:SOURCE<hw>]:BB:GNSS:SV:SBAS:EGNOS:NMESSage:NAV:TIME:CONVersion:UTC: AONE.....	556
[:SOURCE<hw>]:BB:GNSS:SV:NAVic:NMESSage:NAV:TIME:CONVersion:UTC:AONE: UNSCaled.....	556
[:SOURCE<hw>]:BB:GNSS:SV:NAVic:NMESSage:NAV:TIME:CONVersion:UTC:AONE.....	556
[:SOURCE<hw>]:BB:GNSS:SV:QZSS:NMESSage:CNAV:TIME:CONVersion:UTC:AONE: UNSCaled.....	556
[:SOURCE<hw>]:BB:GNSS:SV:QZSS:NMESSage:CNAV:TIME:CONVersion:UTC:AONE.....	556
[:SOURCE<hw>]:BB:GNSS:SV:QZSS:NMESSage:NAV:TIME:CONVersion:UTC:AONE: UNSCaled.....	556
[:SOURCE<hw>]:BB:GNSS:SV:QZSS:NMESSage:NAV:TIME:CONVersion:UTC:AONE.....	556
[:SOURCE<hw>]:BB:GNSS:SV:GALileo:NMESSage:FNAV:TIME:CONVersion:UTC: AONE:UNSCaled.....	556
[:SOURCE<hw>]:BB:GNSS:SV:GALileo:NMESSage:FNAV:TIME:CONVersion:UTC:AONE.....	556
[:SOURCE<hw>]:BB:GNSS:SV:GALileo:NMESSage:INAV:TIME:CONVersion:UTC: AONE:UNSCaled.....	556
[:SOURCE<hw>]:BB:GNSS:SV:GALileo:NMESSage:INAV:TIME:CONVersion:UTC:AONE.....	556
[:SOURCE<hw>]:BB:GNSS:SV:GLONass:NMESSage:NAV:TIME:CONVersion:UTC: AONE:UNSCaled.....	556
[:SOURCE<hw>]:BB:GNSS:SV:GLONass:NMESSage:NAV:TIME:CONVersion:UTC:AONE.....	556
[:SOURCE<hw>]:BB:GNSS:SV:BEIDou:NMESSage:CNAV:TIME:CONVersion:UTC: AONE:UNSCaled.....	556
[:SOURCE<hw>]:BB:GNSS:SV:BEIDou:NMESSage:CNAV:TIME:CONVersion:UTC:AONE.....	556

Navigation message commands

[:SOURce<hw>]:BB:GNSS:SV:BEIDou:NMESsage:DNAV:TIME:CONVersion:UTC: AONE:UNSCaled.....	556
[:SOURce<hw>]:BB:GNSS:SV:BEIDou:NMESsage:DNAV:TIME:CONVersion:UTC:AONE.....	556
[:SOURce<hw>]:BB:GNSS:SV:GPS:NMESsage:CNAV:TIME:CONVersion:UTC:AONE: UNSCaled.....	557
[:SOURce<hw>]:BB:GNSS:SV:GPS:NMESsage:CNAV:TIME:CONVersion:UTC:AONE.....	557
[:SOURce<hw>]:BB:GNSS:SV:GPS:NMESsage:LNAV:TIME:CONVersion:UTC:AONE: UNSCaled.....	557
[:SOURce<hw>]:BB:GNSS:SV:GPS:NMESsage:LNAV:TIME:CONVersion:UTC:AONE.....	557
[:SOURce<hw>]:BB:GNSS:SV:SBAS:WAAS:NMESsage:NAV:TIME:CONVersion:UTC: AZERo:UNSCaled.....	557
[:SOURce<hw>]:BB:GNSS:SV:SBAS:WAAS:NMESsage:NAV:TIME:CONVersion:UTC: AZERo.....	557
[:SOURce<hw>]:BB:GNSS:SV:SBAS:MSAS:NMESsage:NAV:TIME:CONVersion:UTC: AZERo:UNSCaled.....	557
[:SOURce<hw>]:BB:GNSS:SV:SBAS:MSAS:NMESsage:NAV:TIME:CONVersion:UTC: AZERo.....	557
[:SOURce<hw>]:BB:GNSS:SV:SBAS:GAGAN:NMESsage:NAV:TIME:CONVersion:UTC: AZERo:UNSCaled.....	557
[:SOURce<hw>]:BB:GNSS:SV:SBAS:GAGAN:NMESsage:NAV:TIME:CONVersion:UTC: AZERo.....	557
[:SOURce<hw>]:BB:GNSS:SV:SBAS:EGNOS:NMESsage:NAV:TIME:CONVersion:UTC: AZERo:UNSCaled.....	557
[:SOURce<hw>]:BB:GNSS:SV:SBAS:EGNOS:NMESsage:NAV:TIME:CONVersion:UTC: AZERo.....	557
[:SOURce<hw>]:BB:GNSS:SV:NAVic:NMESsage:NAV:TIME:CONVersion:UTC:AZERo: UNSCaled.....	557
[:SOURce<hw>]:BB:GNSS:SV:NAVic:NMESsage:NAV:TIME:CONVersion:UTC:AZERo.....	557
[:SOURce<hw>]:BB:GNSS:SV:QZSS:NMESsage:CNAV:TIME:CONVersion:UTC: AZERo:UNSCaled.....	557
[:SOURce<hw>]:BB:GNSS:SV:QZSS:NMESsage:CNAV:TIME:CONVersion:UTC:AZERo.....	557
[:SOURce<hw>]:BB:GNSS:SV:QZSS:NMESsage:NAV:TIME:CONVersion:UTC:AZERo: UNSCaled.....	557
[:SOURce<hw>]:BB:GNSS:SV:QZSS:NMESsage:NAV:TIME:CONVersion:UTC:AZERo.....	557
[:SOURce<hw>]:BB:GNSS:SV:GALileo:NMESsage:FNAV:TIME:CONVersion:UTC: AZERo:UNSCaled.....	557
[:SOURce<hw>]:BB:GNSS:SV:GALileo:NMESsage:FNAV:TIME:CONVersion:UTC:AZERo.....	557
[:SOURce<hw>]:BB:GNSS:SV:GALileo:NMESsage:INAV:TIME:CONVersion:UTC: AZERo:UNSCaled.....	557
[:SOURce<hw>]:BB:GNSS:SV:GALileo:NMESsage:INAV:TIME:CONVersion:UTC:AZERo.....	558
[:SOURce<hw>]:BB:GNSS:SV:GLONass:NMESsage:NAV:TIME:CONVersion:UTC: AZERo:UNSCaled.....	558
[:SOURce<hw>]:BB:GNSS:SV:GLONass:NMESsage:NAV:TIME:CONVersion:UTC:AZERo.....	558
[:SOURce<hw>]:BB:GNSS:SV:BEIDou:NMESsage:CNAV:TIME:CONVersion:UTC: AZERo:UNSCaled.....	558
[:SOURce<hw>]:BB:GNSS:SV:BEIDou:NMESsage:CNAV:TIME:CONVersion:UTC:AZERo.....	558
[:SOURce<hw>]:BB:GNSS:SV:BEIDou:NMESsage:DNAV:TIME:CONVersion:UTC: AZERo:UNSCaled.....	558
[:SOURce<hw>]:BB:GNSS:SV:BEIDou:NMESsage:DNAV:TIME:CONVersion:UTC:AZERo.....	558

Navigation message commands

[:SOURce<hw>]:BB:GNSS:SV:GPS:NMESSage:CNAV:TIME:CONVersion:UTC:AZERo: UNSCaled.....	558
[:SOURce<hw>]:BB:GNSS:SV:GPS:NMESSage:CNAV:TIME:CONVersion:UTC:AZERo.....	558
[:SOURce<hw>]:BB:GNSS:SV:GPS:NMESSage:LNAV:TIME:CONVersion:UTC:AZERo: UNSCaled.....	558
[:SOURce<hw>]:BB:GNSS:SV:GPS:NMESSage:LNAV:TIME:CONVersion:UTC:AZERo.....	558
[:SOURce<hw>]:BB:GNSS:SV:NAVic:NMESSage:NAV:TIME:CONVersion:GPS:WNOT.....	558
[:SOURce<hw>]:BB:GNSS:SV:GALileo:NMESSage:FNAV:TIME:CONVersion:GPS:WNOT...	558
[:SOURce<hw>]:BB:GNSS:SV:GALileo:NMESSage:INAV:TIME:CONVersion:GPS:WNOT.....	558
[:SOURce<hw>]:BB:GNSS:SV:NAVic:NMESSage:NAV:TIME:CONVersion:GPS:TOT: UNSCaled.....	558
[:SOURce<hw>]:BB:GNSS:SV:NAVic:NMESSage:NAV:TIME:CONVersion:GPS:TOT.....	558
[:SOURce<hw>]:BB:GNSS:SV:BEIDou:NMESSage:CNAV:TIME:CONVersion:GPS:TOT: UNSCaled.....	558
[:SOURce<hw>]:BB:GNSS:SV:BEIDou:NMESSage:CNAV:TIME:CONVersion:GPS:TOT.....	559
[:SOURce<hw>]:BB:GNSS:SV:BEIDou:NMESSage:DNAV:TIME:CONVersion:GPS:TOT: UNSCaled.....	559
[:SOURce<hw>]:BB:GNSS:SV:BEIDou:NMESSage:DNAV:TIME:CONVersion:GPS:TOT.....	559
[:SOURce<hw>]:BB:GNSS:SV:GALileo:NMESSage:FNAV:TIME:CONVersion:GPS:TOT: UNSCaled.....	559
[:SOURce<hw>]:BB:GNSS:SV:GALileo:NMESSage:FNAV:TIME:CONVersion:GPS:TOT.....	559
[:SOURce<hw>]:BB:GNSS:SV:GALileo:NMESSage:INAV:TIME:CONVersion:GPS:TOT: UNSCaled.....	559
[:SOURce<hw>]:BB:GNSS:SV:GALileo:NMESSage:INAV:TIME:CONVersion:GPS:TOT.....	559
[:SOURce<hw>]:BB:GNSS:SV:NAVic:NMESSage:NAV:TIME:CONVersion:GPS:AZERo: UNSCaled.....	559
[:SOURce<hw>]:BB:GNSS:SV:NAVic:NMESSage:NAV:TIME:CONVersion:GPS:AZERo.....	559
[:SOURce<hw>]:BB:GNSS:SV:GLONass:NMESSage:NAV:TIME:CONVersion:GPS: AZERo:UNSCaled.....	559
[:SOURce<hw>]:BB:GNSS:SV:GLONass:NMESSage:NAV:TIME:CONVersion:GPS:AZERo..	559
[:SOURce<hw>]:BB:GNSS:SV:GALileo:NMESSage:FNAV:TIME:CONVersion:GPS: AZERo:UNSCaled.....	559
[:SOURce<hw>]:BB:GNSS:SV:GALileo:NMESSage:FNAV:TIME:CONVersion:GPS:AZERo...	559
[:SOURce<hw>]:BB:GNSS:SV:GALileo:NMESSage:INAV:TIME:CONVersion:GPS: AZERo:UNSCaled.....	559
[:SOURce<hw>]:BB:GNSS:SV:GALileo:NMESSage:INAV:TIME:CONVersion:GPS:AZERo....	559
[:SOURce<hw>]:BB:GNSS:SV:BEIDou:NMESSage:CNAV:TIME:CONVersion:GPS: AZERo:UNSCaled.....	559
[:SOURce<hw>]:BB:GNSS:SV:BEIDou:NMESSage:CNAV:TIME:CONVersion:GPS:AZERo...	559
[:SOURce<hw>]:BB:GNSS:SV:BEIDou:NMESSage:DNAV:TIME:CONVersion:GPS: AZERo:UNSCaled.....	559
[:SOURce<hw>]:BB:GNSS:SV:BEIDou:NMESSage:DNAV:TIME:CONVersion:GPS:AZERo...	559
[:SOURce<hw>]:BB:GNSS:SV:NAVic:NMESSage:NAV:TIME:CONVersion:GPS:AONE: UNSCaled.....	560
[:SOURce<hw>]:BB:GNSS:SV:NAVic:NMESSage:NAV:TIME:CONVersion:GPS:AONE.....	560
[:SOURce<hw>]:BB:GNSS:SV:GALileo:NMESSage:FNAV:TIME:CONVersion:GPS: AONE:UNSCaled.....	560
[:SOURce<hw>]:BB:GNSS:SV:GALileo:NMESSage:FNAV:TIME:CONVersion:GPS:AONE....	560
[:SOURce<hw>]:BB:GNSS:SV:GALileo:NMESSage:INAV:TIME:CONVersion:GPS: AONE:UNSCaled.....	560

Navigation message commands

[:SOURce<hw>]:BB:GNSS:SV:GALileo:NMESsage:INAV:TIME:CONVersion:GPS:AONE..... 560

[:SOURce<hw>]:BB:GNSS:SV:BEIDou:NMESsage:CNAV:TIME:CONVersion:GPS:
AONE:UNSCaled..... 560

[:SOURce<hw>]:BB:GNSS:SV:BEIDou:NMESsage:CNAV:TIME:CONVersion:GPS:AONE.... 560

[:SOURce<hw>]:BB:GNSS:SV:BEIDou:NMESsage:DNAV:TIME:CONVersion:GPS:
AONE:UNSCaled..... 560

[:SOURce<hw>]:BB:GNSS:SV:BEIDou:NMESsage:DNAV:TIME:CONVersion:GPS:AONE.... 560

[:SOURce<hw>]:BB:GNSS:SV:NAVic:NMESsage:NAV:TIME:CONVersion:GPS:ATWO:
UNSCaled..... 560

[:SOURce<hw>]:BB:GNSS:SV:NAVic:NMESsage:NAV:TIME:CONVersion:GPS:ATWO..... 560

[:SOURce<hw>]:BB:GNSS:SV:GPS:NMESsage:CNAV:TIME:CONVersion:GALileo:WNOT... 560

[:SOURce<hw>]:BB:GNSS:SV:BEIDou:NMESsage:CNAV:TIME:CONVersion:GALileo:
TOT:UNSCaled..... 561

[:SOURce<hw>]:BB:GNSS:SV:BEIDou:NMESsage:CNAV:TIME:CONVersion:GALileo:TOT.. 561

[:SOURce<hw>]:BB:GNSS:SV:BEIDou:NMESsage:DNAV:TIME:CONVersion:GALileo:
TOT:UNSCaled..... 561

[:SOURce<hw>]:BB:GNSS:SV:BEIDou:NMESsage:DNAV:TIME:CONVersion:GALileo:TOT.. 561

[:SOURce<hw>]:BB:GNSS:SV:GPS:NMESsage:CNAV:TIME:CONVersion:GALileo:TOT:
UNSCaled..... 561

[:SOURce<hw>]:BB:GNSS:SV:GPS:NMESsage:CNAV:TIME:CONVersion:GALileo:TOT..... 561

[:SOURce<hw>]:BB:GNSS:SV:BEIDou:NMESsage:CNAV:TIME:CONVersion:GALileo:
AZERo:UNSCaled..... 561

[:SOURce<hw>]:BB:GNSS:SV:BEIDou:NMESsage:CNAV:TIME:CONVersion:GALileo:
AZERo..... 561

[:SOURce<hw>]:BB:GNSS:SV:BEIDou:NMESsage:DNAV:TIME:CONVersion:GALileo:
AZERo:UNSCaled..... 561

[:SOURce<hw>]:BB:GNSS:SV:BEIDou:NMESsage:DNAV:TIME:CONVersion:GALileo:
AZERo..... 561

[:SOURce<hw>]:BB:GNSS:SV:GPS:NMESsage:CNAV:TIME:CONVersion:GALileo:
AZERo:UNSCaled..... 561

[:SOURce<hw>]:BB:GNSS:SV:GPS:NMESsage:CNAV:TIME:CONVersion:GALileo:AZERo... 561

[:SOURce<hw>]:BB:GNSS:SV:BEIDou:NMESsage:CNAV:TIME:CONVersion:GALileo:
AONE:UNSCaled..... 561

[:SOURce<hw>]:BB:GNSS:SV:BEIDou:NMESsage:CNAV:TIME:CONVersion:GALileo:
AONE..... 561

[:SOURce<hw>]:BB:GNSS:SV:BEIDou:NMESsage:DNAV:TIME:CONVersion:GALileo:
AONE:UNSCaled..... 561

[:SOURce<hw>]:BB:GNSS:SV:BEIDou:NMESsage:DNAV:TIME:CONVersion:GALileo:
AONE..... 561

[:SOURce<hw>]:BB:GNSS:SV:GPS:NMESsage:CNAV:TIME:CONVersion:GALileo:
AONE:UNSCaled..... 562

[:SOURce<hw>]:BB:GNSS:SV:GPS:NMESsage:CNAV:TIME:CONVersion:GALileo:AONE.... 562

[:SOURce<hw>]:BB:GNSS:SV:GPS:NMESsage:CNAV:TIME:CONVersion:GALileo:
ATWO:UNSCaled..... 562

[:SOURce<hw>]:BB:GNSS:SV:GPS:NMESsage:CNAV:TIME:CONVersion:GALileo:ATWO... 562

[:SOURce<hw>]:BB:GNSS:SV:GPS:NMESsage:CNAV:TIME:CONVersion:GLONass:
WNOT..... 562

[:SOURce<hw>]:BB:GNSS:SV:BEIDou:NMESsage:CNAV:TIME:CONVersion:GLONass:
TOT:UNSCaled..... 562

Navigation message commands

[:SOURce<hw>]:BB:GNSS:SV:BEIDou:NMESsage:CNAV:TIME:CONVersion:GLONass:TOT.....562

[:SOURce<hw>]:BB:GNSS:SV:BEIDou:NMESsage:DNAV:TIME:CONVersion:GLONass:TOT:UNSCaled.....562

[:SOURce<hw>]:BB:GNSS:SV:BEIDou:NMESsage:DNAV:TIME:CONVersion:GLONass:TOT.....562

[:SOURce<hw>]:BB:GNSS:SV:GPS:NMESsage:CNAV:TIME:CONVersion:GLONass:TOT:UNSCaled.....562

[:SOURce<hw>]:BB:GNSS:SV:GPS:NMESsage:CNAV:TIME:CONVersion:GLONass:TOT....562

[:SOURce<hw>]:BB:GNSS:SV:BEIDou:NMESsage:CNAV:TIME:CONVersion:GLONass:AZERo:UNSCaled.....563

[:SOURce<hw>]:BB:GNSS:SV:BEIDou:NMESsage:CNAV:TIME:CONVersion:GLONass:AZERo.....563

[:SOURce<hw>]:BB:GNSS:SV:BEIDou:NMESsage:DNAV:TIME:CONVersion:GLONass:AZERo:UNSCaled.....563

[:SOURce<hw>]:BB:GNSS:SV:BEIDou:NMESsage:DNAV:TIME:CONVersion:GLONass:AZERo.....563

[:SOURce<hw>]:BB:GNSS:SV:GPS:NMESsage:CNAV:TIME:CONVersion:GLONass:AZERo:UNSCaled.....563

[:SOURce<hw>]:BB:GNSS:SV:GPS:NMESsage:CNAV:TIME:CONVersion:GLONass:AZERo.....563

[:SOURce<hw>]:BB:GNSS:SV:BEIDou:NMESsage:CNAV:TIME:CONVersion:GLONass:AONE:UNSCaled.....563

[:SOURce<hw>]:BB:GNSS:SV:BEIDou:NMESsage:CNAV:TIME:CONVersion:GLONass:AONE.....563

[:SOURce<hw>]:BB:GNSS:SV:BEIDou:NMESsage:DNAV:TIME:CONVersion:GLONass:AONE:UNSCaled.....563

[:SOURce<hw>]:BB:GNSS:SV:BEIDou:NMESsage:DNAV:TIME:CONVersion:GLONass:AONE.....563

[:SOURce<hw>]:BB:GNSS:SV:GPS:NMESsage:CNAV:TIME:CONVersion:GLONass:AONE:UNSCaled.....563

[:SOURce<hw>]:BB:GNSS:SV:GPS:NMESsage:CNAV:TIME:CONVersion:GLONass:AONE.....563

[:SOURce<hw>]:BB:GNSS:SV:GPS:NMESsage:CNAV:TIME:CONVersion:GLONass:ATWO:UNSCaled.....563

[:SOURce<hw>]:BB:GNSS:SV:GPS:NMESsage:CNAV:TIME:CONVersion:GLONass:ATWO.....563

[:SOURce<hw>]:BB:GNSS:ATMospheric:NAVic:NMESsage:NAV:IONospheric:ALPHa<ch0>:UNSCaled.....564

[:SOURce<hw>]:BB:GNSS:ATMospheric:NAVic:NMESsage:NAV:IONospheric:ALPHa<ch0>.....564

[:SOURce<hw>]:BB:GNSS:ATMospheric:QZSS:NMESsage:CNAV:IONospheric:ALPHa<ch0>:UNSCaled.....564

[:SOURce<hw>]:BB:GNSS:ATMospheric:QZSS:NMESsage:CNAV:IONospheric:ALPHa<ch0>.....564

[:SOURce<hw>]:BB:GNSS:ATMospheric:QZSS:NMESsage:NAV:IONospheric:ALPHa<ch0>:UNSCaled.....564

[:SOURce<hw>]:BB:GNSS:ATMospheric:QZSS:NMESsage:NAV:IONospheric:ALPHa<ch0>.....564

Navigation message commands

[:SOURCE<hw>]:BB:GNSS:ATMospheric:BEIDou:NMESSage:CNAV:IONospheric: ALPHA<ch0>:UNSCaled.....	564
[:SOURCE<hw>]:BB:GNSS:ATMospheric:BEIDou:NMESSage:CNAV:IONospheric: ALPHA<ch0>.....	564
[:SOURCE<hw>]:BB:GNSS:ATMospheric:BEIDou:NMESSage:DNAV:IONospheric: ALPHA<ch0>:UNSCaled.....	564
[:SOURCE<hw>]:BB:GNSS:ATMospheric:BEIDou:NMESSage:DNAV:IONospheric: ALPHA<ch0>.....	564
[:SOURCE<hw>]:BB:GNSS:ATMospheric:GPS:NMESSage:CNAV:IONospheric: ALPHA<ch0>:UNSCaled.....	564
[:SOURCE<hw>]:BB:GNSS:ATMospheric:GPS:NMESSage:CNAV:IONospheric: ALPHA<ch0>.....	564
[:SOURCE<hw>]:BB:GNSS:ATMospheric:GPS:NMESSage:LNAV:IONospheric: ALPHA<ch0>:UNSCaled.....	564
[:SOURCE<hw>]:BB:GNSS:ATMospheric:GPS:NMESSage:LNAV:IONospheric: ALPHA<ch0>.....	564
[:SOURCE<hw>]:BB:GNSS:ATMospheric:GALileo:NMESSage:FNAV:IONospheric: AI<ch0>:UNSCaled.....	564
[:SOURCE<hw>]:BB:GNSS:ATMospheric:GALileo:NMESSage:FNAV:IONospheric:AI<ch0>.....	564
[:SOURCE<hw>]:BB:GNSS:ATMospheric:GALileo:NMESSage:INAV:IONospheric: AI<ch0>:UNSCaled.....	564
[:SOURCE<hw>]:BB:GNSS:ATMospheric:GALileo:NMESSage:INAV:IONospheric:AI<ch0>.....	564
[:SOURCE<hw>]:BB:GNSS:ATMospheric:NAVic:NMESSage:NAV:IONospheric: BETA<ch0>:UNSCaled.....	565
[:SOURCE<hw>]:BB:GNSS:ATMospheric:NAVic:NMESSage:NAV:IONospheric:BETA<ch0>.....	565
[:SOURCE<hw>]:BB:GNSS:ATMospheric:QZSS:NMESSage:CNAV:IONospheric: BETA<ch0>:UNSCaled.....	565
[:SOURCE<hw>]:BB:GNSS:ATMospheric:QZSS:NMESSage:CNAV:IONospheric: BETA<ch0>.....	565
[:SOURCE<hw>]:BB:GNSS:ATMospheric:QZSS:NMESSage:NAV:IONospheric: BETA<ch0>:UNSCaled.....	565
[:SOURCE<hw>]:BB:GNSS:ATMospheric:QZSS:NMESSage:NAV:IONospheric:BETA<ch0>.....	565
[:SOURCE<hw>]:BB:GNSS:ATMospheric:BEIDou:NMESSage:CNAV:IONospheric: BETA<ch0>:UNSCaled.....	565
[:SOURCE<hw>]:BB:GNSS:ATMospheric:BEIDou:NMESSage:CNAV:IONospheric: BETA<ch0>.....	565
[:SOURCE<hw>]:BB:GNSS:ATMospheric:BEIDou:NMESSage:DNAV:IONospheric: BETA<ch0>:UNSCaled.....	565
[:SOURCE<hw>]:BB:GNSS:ATMospheric:BEIDou:NMESSage:DNAV:IONospheric: BETA<ch0>.....	565
[:SOURCE<hw>]:BB:GNSS:ATMospheric:GPS:NMESSage:CNAV:IONospheric: BETA<ch0>:UNSCaled.....	565
[:SOURCE<hw>]:BB:GNSS:ATMospheric:GPS:NMESSage:CNAV:IONospheric:BETA<ch0>.....	565
[:SOURCE<hw>]:BB:GNSS:ATMospheric:GPS:NMESSage:LNAV:IONospheric: BETA<ch0>:UNSCaled.....	565
[:SOURCE<hw>]:BB:GNSS:ATMospheric:GPS:NMESSage:LNAV:IONospheric:BETA<ch0>.....	565
[:SOURCE<hw>]:BB:GNSS:ATMospheric:GALileo:NMESSage:FNAV:IONospheric:SF<ch>.....	566
[:SOURCE<hw>]:BB:GNSS:ATMospheric:GALileo:NMESSage:INAV:IONospheric:SF<ch>.....	566

**[:SOURCE<hw>]:BB:GNSS:SVID<ch>:GALileo:NMESsage:FNAV:EPHemeris:
IODNav <IODnav>**

**[:SOURCE<hw>]:BB:GNSS:SVID<ch>:GALileo:NMESsage:INAV:EPHemeris:
IODNav <IODnav>**

Sets the IODnav parameter.

Parameters:

<IODnav>	integer	
	Range:	0 to 1023
	*RST:	0

**[:SOURCE<hw>]:BB:GNSS:SVID<ch>:NAVic:NMESsage:NAV:EPHemeris:IODE
<IODde>**

**[:SOURCE<hw>]:BB:GNSS:SVID<ch>:QZSS:NMESsage:NAV:EPHemeris:IODE
<IODde>**

**[:SOURCE<hw>]:BB:GNSS:SVID<ch>:BEIDou:NMESsage:DNAV:EPHemeris:IODE
<IODe>**

**[:SOURCE<hw>]:BB:GNSS:SVID<ch>:GPS:NMESsage:LNAV:EPHemeris:IODE
<IODe>**

Sets the issue of data, ephemeris.

Parameters:

<IODe>	integer	
	Range:	0 to 255
	*RST:	0

**[:SOURCE<hw>]:BB:GNSS:SVID<ch>:SBAS:NMESsage:NAV:EPHemeris:TOE:
UNSCaled <Toe>**

**[:SOURCE<hw>]:BB:GNSS:SVID<ch>:SBAS:NMESsage:NAV:EPHemeris:TOE
<Toe>**

**[:SOURCE<hw>]:BB:GNSS:SVID<ch>:NAVic:NMESsage:NAV:EPHemeris:TOE:
UNSCaled <Toe>**

**[:SOURCE<hw>]:BB:GNSS:SVID<ch>:NAVic:NMESsage:NAV:EPHemeris:TOE
<Toe>**

**[:SOURCE<hw>]:BB:GNSS:SVID<ch>:QZSS:NMESsage:CNAV:EPHemeris:TOE:
UNSCaled <Toe>**

**[:SOURCE<hw>]:BB:GNSS:SVID<ch>:QZSS:NMESsage:CNAV:EPHemeris:TOE
<Toe>**

**[:SOURCE<hw>]:BB:GNSS:SVID<ch>:QZSS:NMESsage:NAV:EPHemeris:TOE:
UNSCaled <Toe>**

**[:SOURCE<hw>]:BB:GNSS:SVID<ch>:QZSS:NMESsage:NAV:EPHemeris:TOE
<Toe>**

**[:SOURCE<hw>]:BB:GNSS:SVID<ch>:GALileo:NMESsage:FNAV:EPHemeris:TOE:
UNSCaled <Toe>**

**[:SOURCE<hw>]:BB:GNSS:SVID<ch>:GALileo:NMESsage:FNAV:EPHemeris:TOE
<Toe>**

```

[:SOURce<hw>]:BB:GNSS:SVID<ch>:GALileo:NMESsage:INAV:EPHemeris:TOE:
  UNSCaled <Toe>
[:SOURce<hw>]:BB:GNSS:SVID<ch>:GALileo:NMESsage:INAV:EPHemeris:TOE
  <Toe>
[:SOURce<hw>]:BB:GNSS:SVID<ch>:BEIDou:NMESsage:CNAV:EPHemeris:TOE:
  UNSCaled <Toe>
[:SOURce<hw>]:BB:GNSS:SVID<ch>:BEIDou:NMESsage:CNAV:EPHemeris:TOE
  <Toe>
[:SOURce<hw>]:BB:GNSS:SVID<ch>:BEIDou:NMESsage:DNAV:EPHemeris:TOE:
  UNSCaled <Toe>
[:SOURce<hw>]:BB:GNSS:SVID<ch>:BEIDou:NMESsage:DNAV:EPHemeris:TOE
  <Toe>
[:SOURce<hw>]:BB:GNSS:SVID<ch>:GPS:NMESsage:CNAV:EPHemeris:TOE:
  UNSCaled <Toe>
[:SOURce<hw>]:BB:GNSS:SVID<ch>:GPS:NMESsage:CNAV:EPHemeris:TOE
  <Toe>
[:SOURce<hw>]:BB:GNSS:SVID<ch>:GPS:NMESsage:LNAV:EPHemeris:TOE:
  UNSCaled <Toe>
[:SOURce<hw>]:BB:GNSS:SVID<ch>:GPS:NMESsage:LNAV:EPHemeris:TOE
  <Toe>

```

Sets the reference time of ephemeris.

Parameters:

```

<Toe>                integer
                       *RST:    0

```

```

[:SOURce<hw>]:BB:GNSS:SVID<ch>:NAVic:NMESsage:NAV:EPHemeris:SQRA:
  UNSCaled <SqrtA>
[:SOURce<hw>]:BB:GNSS:SVID<ch>:NAVic:NMESsage:NAV:EPHemeris:SQRA
  <SqrtA>
[:SOURce<hw>]:BB:GNSS:SVID<ch>:QZSS:NMESsage:CNAV:EPHemeris:SQRA:
  UNSCaled <SqrtA>
[:SOURce<hw>]:BB:GNSS:SVID<ch>:QZSS:NMESsage:CNAV:EPHemeris:SQRA
  <SqrtA>
[:SOURce<hw>]:BB:GNSS:SVID<ch>:QZSS:NMESsage:NAV:EPHemeris:SQRA:
  UNSCaled <SqrtA>
[:SOURce<hw>]:BB:GNSS:SVID<ch>:QZSS:NMESsage:NAV:EPHemeris:SQRA
  <SqrtA>
[:SOURce<hw>]:BB:GNSS:SVID<ch>:GALileo:NMESsage:FNAV:EPHemeris:
  SQRA:UNSCaled <SqrtA>
[:SOURce<hw>]:BB:GNSS:SVID<ch>:GALileo:NMESsage:FNAV:EPHemeris:
  SQRA <SqrtA>
[:SOURce<hw>]:BB:GNSS:SVID<ch>:GALileo:NMESsage:INAV:EPHemeris:
  SQRA:UNSCaled <SqrtA>
[:SOURce<hw>]:BB:GNSS:SVID<ch>:GALileo:NMESsage:INAV:EPHemeris:
  SQRA <SqrtA>
[:SOURce<hw>]:BB:GNSS:SVID<ch>:BEIDou:NMESsage:CNAV:EPHemeris:
  SQRA:UNSCaled <SqrtA>

```

```

[:SOURce<hw>]:BB:GNSS:SVID<ch>:BEIDou:NMESsage:CNAV:EPHemeris:
  SQRA <SqrtA>
[:SOURce<hw>]:BB:GNSS:SVID<ch>:BEIDou:NMESsage:DNAV:EPHemeris:
  SQRA:UNSCaled <SqrtA>
[:SOURce<hw>]:BB:GNSS:SVID<ch>:BEIDou:NMESsage:DNAV:EPHemeris:
  SQRA <SqrtA>
[:SOURce<hw>]:BB:GNSS:SVID<ch>:GPS:NMESsage:CNAV:EPHemeris:SQRA:
  UNSCaled <SqrtA>
[:SOURce<hw>]:BB:GNSS:SVID<ch>:GPS:NMESsage:CNAV:EPHemeris:SQRA
  <SqrtA>
[:SOURce<hw>]:BB:GNSS:SVID<ch>:GPS:NMESsage:LNAV:EPHemeris:SQRA:
  UNSCaled <SqrtA>
[:SOURce<hw>]:BB:GNSS:SVID<ch>:GPS:NMESsage:LNAV:EPHemeris:SQRA
  <SqrtA>

```

Sets the square root of semi-major axis.

Parameters:

<SqrtA>	integer	
	Range:	0 to 4294967295
	*RST:	depends on installed options

```

[:SOURce<hw>]:BB:GNSS:SVID<ch>:NAVic:NMESsage:NAV:EPHemeris:
  ECCentricity:UNSCaled <Eccentricity>
[:SOURce<hw>]:BB:GNSS:SVID<ch>:NAVic:NMESsage:NAV:EPHemeris:
  ECCentricity <Eccentricity>
[:SOURce<hw>]:BB:GNSS:SVID<ch>:QZSS:NMESsage:CNAV:EPHemeris:
  ECCentricity:UNSCaled <Eccentricity>
[:SOURce<hw>]:BB:GNSS:SVID<ch>:QZSS:NMESsage:CNAV:EPHemeris:
  ECCentricity <Eccentricity>
[:SOURce<hw>]:BB:GNSS:SVID<ch>:QZSS:NMESsage:NAV:EPHemeris:
  ECCentricity:UNSCaled <Eccentricity>
[:SOURce<hw>]:BB:GNSS:SVID<ch>:QZSS:NMESsage:NAV:EPHemeris:
  ECCentricity <Eccentricity>
[:SOURce<hw>]:BB:GNSS:SVID<ch>:GALileo:NMESsage:FNAV:EPHemeris:
  ECCentricity:UNSCaled <Eccentricity>
[:SOURce<hw>]:BB:GNSS:SVID<ch>:GALileo:NMESsage:FNAV:EPHemeris:
  ECCentricity <Eccentricity>
[:SOURce<hw>]:BB:GNSS:SVID<ch>:GALileo:NMESsage:INAV:EPHemeris:
  ECCentricity:UNSCaled <Eccentricity>
[:SOURce<hw>]:BB:GNSS:SVID<ch>:GALileo:NMESsage:INAV:EPHemeris:
  ECCentricity <Eccentricity>
[:SOURce<hw>]:BB:GNSS:SVID<ch>:BEIDou:NMESsage:CNAV:EPHemeris:
  ECCentricity:UNSCaled <Eccentricity>
[:SOURce<hw>]:BB:GNSS:SVID<ch>:BEIDou:NMESsage:CNAV:EPHemeris:
  ECCentricity <Eccentricity>
[:SOURce<hw>]:BB:GNSS:SVID<ch>:BEIDou:NMESsage:DNAV:EPHemeris:
  ECCentricity:UNSCaled <Eccentricity>
[:SOURce<hw>]:BB:GNSS:SVID<ch>:BEIDou:NMESsage:DNAV:EPHemeris:
  ECCentricity <Eccentricity>

```

```
[:SOURce<hw>]:BB:GNSS:SVID<ch>:GPS:NMESsage:CNAV:EPHemeris:
  ECCentricity:UNSCaled <Eccentricity>
[:SOURce<hw>]:BB:GNSS:SVID<ch>:GPS:NMESsage:CNAV:EPHemeris:
  ECCentricity <Eccentricity>
[:SOURce<hw>]:BB:GNSS:SVID<ch>:GPS:NMESsage:LNAV:EPHemeris:
  ECCentricity:UNSCaled <Eccentricity>
[:SOURce<hw>]:BB:GNSS:SVID<ch>:GPS:NMESsage:LNAV:EPHemeris:
  ECCentricity <Eccentricity>
```

Sets the eccentricity.

Parameters:

```
<Eccentricity>      integer
                    *RST:      0
```

```
[:SOURce<hw>]:BB:GNSS:SVID<ch>:NAVic:NMESsage:NAV:EPHemeris:IZERo:
  UNSCaled <I0>
[:SOURce<hw>]:BB:GNSS:SVID<ch>:NAVic:NMESsage:NAV:EPHemeris:IZERo
  <I0>
[:SOURce<hw>]:BB:GNSS:SVID<ch>:QZSS:NMESsage:CNAV:EPHemeris:IZERo:
  UNSCaled <I0>
[:SOURce<hw>]:BB:GNSS:SVID<ch>:QZSS:NMESsage:CNAV:EPHemeris:IZERo
  <I0>
[:SOURce<hw>]:BB:GNSS:SVID<ch>:QZSS:NMESsage:NAV:EPHemeris:IZERo:
  UNSCaled <I0>
[:SOURce<hw>]:BB:GNSS:SVID<ch>:QZSS:NMESsage:NAV:EPHemeris:IZERo
  <I0>
[:SOURce<hw>]:BB:GNSS:SVID<ch>:GALileo:NMESsage:FNAV:EPHemeris:
  IZERo:UNSCaled <I0>
[:SOURce<hw>]:BB:GNSS:SVID<ch>:GALileo:NMESsage:FNAV:EPHemeris:
  IZERo <I0>
[:SOURce<hw>]:BB:GNSS:SVID<ch>:GALileo:NMESsage:INAV:EPHemeris:
  IZERo:UNSCaled <I0>
[:SOURce<hw>]:BB:GNSS:SVID<ch>:GALileo:NMESsage:INAV:EPHemeris:
  IZERo <I0>
[:SOURce<hw>]:BB:GNSS:SVID<ch>:BEIDou:NMESsage:CNAV:EPHemeris:
  IZERo:UNSCaled <I0>
[:SOURce<hw>]:BB:GNSS:SVID<ch>:BEIDou:NMESsage:CNAV:EPHemeris:
  IZERo <I0>
[:SOURce<hw>]:BB:GNSS:SVID<ch>:BEIDou:NMESsage:DNAV:EPHemeris:
  IZERo:UNSCaled <I0>
[:SOURce<hw>]:BB:GNSS:SVID<ch>:BEIDou:NMESsage:DNAV:EPHemeris:
  IZERo <I0>
[:SOURce<hw>]:BB:GNSS:SVID<ch>:GPS:NMESsage:CNAV:EPHemeris:IZERo:
  UNSCaled <I0>
[:SOURce<hw>]:BB:GNSS:SVID<ch>:GPS:NMESsage:CNAV:EPHemeris:IZERo
  <I0>
```

**[:SOURce<hw>]:BB:GNSS:SVID<ch>:GPS:NMESsage:LNAV:EPHemeris:IZERo:
UNSCaled <I0>**

**[:SOURce<hw>]:BB:GNSS:SVID<ch>:GPS:NMESsage:LNAV:EPHemeris:IZERo
<I0>**

Sets the inclination angle.

Parameters:

<I0> integer
*RST: 0

**[:SOURce<hw>]:BB:GNSS:SVID<ch>:NAVic:NMESsage:NAV:EPHemeris:OZERo:
UNSCaled <Omega0>**

**[:SOURce<hw>]:BB:GNSS:SVID<ch>:NAVic:NMESsage:NAV:EPHemeris:OZERo
<Omega0>**

**[:SOURce<hw>]:BB:GNSS:SVID<ch>:QZSS:NMESsage:CNAV:EPHemeris:
OZERo:UNSCaled <Omega0>**

**[:SOURce<hw>]:BB:GNSS:SVID<ch>:QZSS:NMESsage:CNAV:EPHemeris:OZERo
<Omega0>**

**[:SOURce<hw>]:BB:GNSS:SVID<ch>:QZSS:NMESsage:NAV:EPHemeris:OZERo:
UNSCaled <Omega0>**

**[:SOURce<hw>]:BB:GNSS:SVID<ch>:QZSS:NMESsage:NAV:EPHemeris:OZERo
<Omega0>**

**[:SOURce<hw>]:BB:GNSS:SVID<ch>:GALileo:NMESsage:FNAV:EPHemeris:
OZERo:UNSCaled <Omega0>**

**[:SOURce<hw>]:BB:GNSS:SVID<ch>:GALileo:NMESsage:FNAV:EPHemeris:
OZERo <Omega0>**

**[:SOURce<hw>]:BB:GNSS:SVID<ch>:GALileo:NMESsage:INAV:EPHemeris:
OZERo:UNSCaled <Omega0>**

**[:SOURce<hw>]:BB:GNSS:SVID<ch>:GALileo:NMESsage:INAV:EPHemeris:
OZERo <Omega0>**

**[:SOURce<hw>]:BB:GNSS:SVID<ch>:BEIDou:NMESsage:CNAV:EPHemeris:
OZERo:UNSCaled <Omega0>**

**[:SOURce<hw>]:BB:GNSS:SVID<ch>:BEIDou:NMESsage:CNAV:EPHemeris:
OZERo <Omega0>**

**[:SOURce<hw>]:BB:GNSS:SVID<ch>:BEIDou:NMESsage:DNAV:EPHemeris:
OZERo:UNSCaled <Omega0>**

**[:SOURce<hw>]:BB:GNSS:SVID<ch>:BEIDou:NMESsage:DNAV:EPHemeris:
OZERo <Omega0>**

**[:SOURce<hw>]:BB:GNSS:SVID<ch>:GPS:NMESsage:CNAV:EPHemeris:OZERo:
UNSCaled <Omega0>**

**[:SOURce<hw>]:BB:GNSS:SVID<ch>:GPS:NMESsage:CNAV:EPHemeris:OZERo
<Omega0>**

**[:SOURce<hw>]:BB:GNSS:SVID<ch>:GPS:NMESsage:LNAV:EPHemeris:OZERo:
UNSCaled <Omega0>**

**[:SOURce<hw>]:BB:GNSS:SVID<ch>:GPS:NMESsage:LNAV:EPHemeris:OZERo
<Omega0>**

Sets the longitude of ascending node.

Parameters:

<Omega0> integer
 *RST: 0

```

[:SOURce<hw>]:BB:GNSS:SVID<ch>:NAVic:NMESsage:NAV:EPHemeris:OMEGa:
  UNSCaLed <Omega>
[:SOURce<hw>]:BB:GNSS:SVID<ch>:NAVic:NMESsage:NAV:EPHemeris:OMEGa
  <Omega>
[:SOURce<hw>]:BB:GNSS:SVID<ch>:QZSS:NMESsage:CNAV:EPHemeris:
  OMEGa:UNSCaLed <Omega>
[:SOURce<hw>]:BB:GNSS:SVID<ch>:QZSS:NMESsage:CNAV:EPHemeris:
  OMEGa <Omega>
[:SOURce<hw>]:BB:GNSS:SVID<ch>:QZSS:NMESsage:NAV:EPHemeris:OMEGa:
  UNSCaLed <Omega>
[:SOURce<hw>]:BB:GNSS:SVID<ch>:QZSS:NMESsage:NAV:EPHemeris:OMEGa
  <Omega>
[:SOURce<hw>]:BB:GNSS:SVID<ch>:GALileo:NMESsage:FNAV:EPHemeris:
  OMEGa:UNSCaLed <Omega>
[:SOURce<hw>]:BB:GNSS:SVID<ch>:GALileo:NMESsage:FNAV:EPHemeris:
  OMEGa <Omega>
[:SOURce<hw>]:BB:GNSS:SVID<ch>:GALileo:NMESsage:INAV:EPHemeris:
  OMEGa:UNSCaLed <Omega>
[:SOURce<hw>]:BB:GNSS:SVID<ch>:GALileo:NMESsage:INAV:EPHemeris:
  OMEGa <Omega>
[:SOURce<hw>]:BB:GNSS:SVID<ch>:BEIDou:NMESsage:CNAV:EPHemeris:
  OMEGa:UNSCaLed <Omega>
[:SOURce<hw>]:BB:GNSS:SVID<ch>:BEIDou:NMESsage:CNAV:EPHemeris:
  OMEGa <Omega>
[:SOURce<hw>]:BB:GNSS:SVID<ch>:BEIDou:NMESsage:DNAV:EPHemeris:
  OMEGa:UNSCaLed <Omega>
[:SOURce<hw>]:BB:GNSS:SVID<ch>:BEIDou:NMESsage:DNAV:EPHemeris:
  OMEGa <Omega>
[:SOURce<hw>]:BB:GNSS:SVID<ch>:GPS:NMESsage:CNAV:EPHemeris:OMEGa:
  UNSCaLed <Omega>
[:SOURce<hw>]:BB:GNSS:SVID<ch>:GPS:NMESsage:CNAV:EPHemeris:OMEGa
  <Omega>
[:SOURce<hw>]:BB:GNSS:SVID<ch>:GPS:NMESsage:LNAV:EPHemeris:OMEGa:
  UNSCaLed <Omega>
[:SOURce<hw>]:BB:GNSS:SVID<ch>:GPS:NMESsage:LNAV:EPHemeris:OMEGa
  <Omega>

```

Sets the argument of perigee.

Parameters:

<Omega> integer
 *RST: 0

```

[:SOURce<hw>]:BB:GNSS:SVID<ch>:NAVic:NMESsage:NAV:EPHemeris:MZERo:
  UNSCaLed <M0>
[:SOURce<hw>]:BB:GNSS:SVID<ch>:NAVic:NMESsage:NAV:EPHemeris:MZERo
  <M0>
[:SOURce<hw>]:BB:GNSS:SVID<ch>:QZSS:NMESsage:CNAV:EPHemeris:
  MZERo:UNSCaLed <M0>
[:SOURce<hw>]:BB:GNSS:SVID<ch>:QZSS:NMESsage:CNAV:EPHemeris:MZERo
  <M0>
[:SOURce<hw>]:BB:GNSS:SVID<ch>:QZSS:NMESsage:NAV:EPHemeris:MZERo:
  UNSCaLed <M0>
[:SOURce<hw>]:BB:GNSS:SVID<ch>:QZSS:NMESsage:NAV:EPHemeris:MZERo
  <M0>
[:SOURce<hw>]:BB:GNSS:SVID<ch>:GALileo:NMESsage:FNAV:EPHemeris:
  MZERo:UNSCaLed <M0>
[:SOURce<hw>]:BB:GNSS:SVID<ch>:GALileo:NMESsage:FNAV:EPHemeris:
  MZERo <M0>
[:SOURce<hw>]:BB:GNSS:SVID<ch>:GALileo:NMESsage:INAV:EPHemeris:
  MZERo:UNSCaLed <M0>
[:SOURce<hw>]:BB:GNSS:SVID<ch>:GALileo:NMESsage:INAV:EPHemeris:
  MZERo <M0>
[:SOURce<hw>]:BB:GNSS:SVID<ch>:BEIDou:NMESsage:CNAV:EPHemeris:
  MZERo:UNSCaLed <M0>
[:SOURce<hw>]:BB:GNSS:SVID<ch>:BEIDou:NMESsage:CNAV:EPHemeris:
  MZERo <M0>
[:SOURce<hw>]:BB:GNSS:SVID<ch>:BEIDou:NMESsage:DNAV:EPHemeris:
  MZERo:UNSCaLed <M0>
[:SOURce<hw>]:BB:GNSS:SVID<ch>:BEIDou:NMESsage:DNAV:EPHemeris:
  MZERo <M0>
[:SOURce<hw>]:BB:GNSS:SVID<ch>:GPS:NMESsage:CNAV:EPHemeris:MZERo:
  UNSCaLed <M0>
[:SOURce<hw>]:BB:GNSS:SVID<ch>:GPS:NMESsage:CNAV:EPHemeris:MZERo
  <M0>
[:SOURce<hw>]:BB:GNSS:SVID<ch>:GPS:NMESsage:LNAV:EPHemeris:MZERo:
  UNSCaLed <M0>
[:SOURce<hw>]:BB:GNSS:SVID<ch>:GPS:NMESsage:LNAV:EPHemeris:MZERo
  <M0>

```

Sets the mean anomaly.

Parameters:

```

<M0>                integer
                    *RST:    0

```

```

[:SOURce<hw>]:BB:GNSS:SVID<ch>:NAVic:NMESsage:NAV:EPHemeris:IDOT:
  UNSCaLed <ldot>
[:SOURce<hw>]:BB:GNSS:SVID<ch>:NAVic:NMESsage:NAV:EPHemeris:IDOT
  <ldot>
[:SOURce<hw>]:BB:GNSS:SVID<ch>:QZSS:NMESsage:CNAV:EPHemeris:IDOT:
  UNSCaLed <ldot>

```

```

[:SOURce<hw>]:BB:GNSS:SVID<ch>:QZSS:NMESsage:CNAV:EPHemeris:IDOT
<Idot>
[:SOURce<hw>]:BB:GNSS:SVID<ch>:QZSS:NMESsage:NAV:EPHemeris:IDOT:
UNSCaled <Idot>
[:SOURce<hw>]:BB:GNSS:SVID<ch>:QZSS:NMESsage:NAV:EPHemeris:IDOT
<Idot>
[:SOURce<hw>]:BB:GNSS:SVID<ch>:GALileo:NMESsage:FNAV:EPHemeris:
IDOT:UNSCaled <Idot>
[:SOURce<hw>]:BB:GNSS:SVID<ch>:GALileo:NMESsage:FNAV:EPHemeris:IDOT
<Idot>
[:SOURce<hw>]:BB:GNSS:SVID<ch>:GALileo:NMESsage:INAV:EPHemeris:IDOT:
UNSCaled <Idot>
[:SOURce<hw>]:BB:GNSS:SVID<ch>:GALileo:NMESsage:INAV:EPHemeris:IDOT
<Idot>
[:SOURce<hw>]:BB:GNSS:SVID<ch>:BEIDou:NMESsage:CNAV:EPHemeris:IDOT:
UNSCaled <Idot>
[:SOURce<hw>]:BB:GNSS:SVID<ch>:BEIDou:NMESsage:CNAV:EPHemeris:IDOT
<Idot>
[:SOURce<hw>]:BB:GNSS:SVID<ch>:BEIDou:NMESsage:DNAV:EPHemeris:IDOT:
UNSCaled <Idot>
[:SOURce<hw>]:BB:GNSS:SVID<ch>:BEIDou:NMESsage:DNAV:EPHemeris:IDOT
<Idot>
[:SOURce<hw>]:BB:GNSS:SVID<ch>:GPS:NMESsage:CNAV:EPHemeris:IDOT:
UNSCaled <Idot>
[:SOURce<hw>]:BB:GNSS:SVID<ch>:GPS:NMESsage:CNAV:EPHemeris:IDOT
<Idot>
[:SOURce<hw>]:BB:GNSS:SVID<ch>:GPS:NMESsage:LNAV:EPHemeris:IDOT:
UNSCaled <Idot>
[:SOURce<hw>]:BB:GNSS:SVID<ch>:GPS:NMESsage:LNAV:EPHemeris:IDOT
<Idot>

```

Sets the rate of inclination angle.

Parameters:

```

<Idot>                integer
                        *RST:    0

```

```

[:SOURce<hw>]:BB:GNSS:SVID<ch>:NAVic:NMESsage:NAV:EPHemeris:ODOT:
UNSCaled <OmegaDot>
[:SOURce<hw>]:BB:GNSS:SVID<ch>:NAVic:NMESsage:NAV:EPHemeris:ODOT
<OmegaDot>
[:SOURce<hw>]:BB:GNSS:SVID<ch>:QZSS:NMESsage:CNAV:EPHemeris:ODOT:
UNSCaled <OmegaDot>
[:SOURce<hw>]:BB:GNSS:SVID<ch>:QZSS:NMESsage:CNAV:EPHemeris:ODOT
<OmegaDot>
[:SOURce<hw>]:BB:GNSS:SVID<ch>:QZSS:NMESsage:NAV:EPHemeris:ODOT:
UNSCaled <OmegaDot>
[:SOURce<hw>]:BB:GNSS:SVID<ch>:QZSS:NMESsage:NAV:EPHemeris:ODOT
<OmegaDot>

```



```

[:SOURce<hw>]:BB:GNSS:SVID<ch>:GALileo:NMESsage:FNAV:EPHemeris:
  ODOT:UNSCaled <OmegaDot>
[:SOURce<hw>]:BB:GNSS:SVID<ch>:GALileo:NMESsage:FNAV:EPHemeris:
  ODOT <OmegaDot>
[:SOURce<hw>]:BB:GNSS:SVID<ch>:GALileo:NMESsage:INAV:EPHemeris:
  ODOT:UNSCaled <OmegaDot>
[:SOURce<hw>]:BB:GNSS:SVID<ch>:GALileo:NMESsage:INAV:EPHemeris:
  ODOT <OmegaDot>
[:SOURce<hw>]:BB:GNSS:SVID<ch>:BEIDou:NMESsage:CNAV:EPHemeris:
  ODOT:UNSCaled <OmegaDot>
[:SOURce<hw>]:BB:GNSS:SVID<ch>:BEIDou:NMESsage:CNAV:EPHemeris:
  ODOT <OmegaDot>
[:SOURce<hw>]:BB:GNSS:SVID<ch>:BEIDou:NMESsage:DNAV:EPHemeris:
  ODOT:UNSCaled <OmegaDot>
[:SOURce<hw>]:BB:GNSS:SVID<ch>:BEIDou:NMESsage:DNAV:EPHemeris:
  ODOT <OmegaDot>
[:SOURce<hw>]:BB:GNSS:SVID<ch>:GPS:NMESsage:CNAV:EPHemeris:ODOT:
  UNSCaled <OmegaDot>
[:SOURce<hw>]:BB:GNSS:SVID<ch>:GPS:NMESsage:CNAV:EPHemeris:ODOT
  <OmegaDot>
[:SOURce<hw>]:BB:GNSS:SVID<ch>:GPS:NMESsage:LNAV:EPHemeris:ODOT:
  UNSCaled <OmegaDot>
[:SOURce<hw>]:BB:GNSS:SVID<ch>:GPS:NMESsage:LNAV:EPHemeris:ODOT
  <OmegaDot>

```

Sets the rate of right ascension.

Parameters:

```

<OmegaDot>      integer
                 *RST:      0

```

```

[:SOURce<hw>]:BB:GNSS:SVID<ch>:QZSS:NMESsage:CNAV:EPHemeris:DODot:
  UNSCaled <DeltaOmegaDot>
[:SOURce<hw>]:BB:GNSS:SVID<ch>:QZSS:NMESsage:CNAV:EPHemeris:DODot
  <DeltaOmegaDot>
[:SOURce<hw>]:BB:GNSS:SVID<ch>:GPS:NMESsage:CNAV:EPHemeris:DODot:
  UNSCaled <DeltaOmegaDot>
[:SOURce<hw>]:BB:GNSS:SVID<ch>:GPS:NMESsage:CNAV:EPHemeris:DODot
  <DeltaOmegaDot>

```

Sets the Rate of right ascension difference.

Parameters:

```

<DeltaOmegaDot> integer
                 *RST:      0

```

```

[:SOURce<hw>]:BB:GNSS:SVID<ch>:NAVic:NMESsage:NAV:EPHemeris:NDELta:
  UNSCaled <DeltaN>
[:SOURce<hw>]:BB:GNSS:SVID<ch>:NAVic:NMESsage:NAV:EPHemeris:NDELta
  <DeltaN>

```

```

[:SOURce<hw>]:BB:GNSS:SVID<ch>:QZSS:NMESsage:CNAV:EPHemeris:
  NDELta:UNSCaled <DeltaN>
[:SOURce<hw>]:BB:GNSS:SVID<ch>:QZSS:NMESsage:CNAV:EPHemeris:
  NDELta <DeltaN>
[:SOURce<hw>]:BB:GNSS:SVID<ch>:QZSS:NMESsage:NAV:EPHemeris:NDELta:
  UNSCaled <DeltaN>
[:SOURce<hw>]:BB:GNSS:SVID<ch>:QZSS:NMESsage:NAV:EPHemeris:NDELta
  <DeltaN>
[:SOURce<hw>]:BB:GNSS:SVID<ch>:GALileo:NMESsage:FNAV:EPHemeris:
  NDELta:UNSCaled <DeltaN>
[:SOURce<hw>]:BB:GNSS:SVID<ch>:GALileo:NMESsage:FNAV:EPHemeris:
  NDELta <DeltaN>
[:SOURce<hw>]:BB:GNSS:SVID<ch>:GALileo:NMESsage:INAV:EPHemeris:
  NDELta:UNSCaled <DeltaN>
[:SOURce<hw>]:BB:GNSS:SVID<ch>:GALileo:NMESsage:INAV:EPHemeris:
  NDELta <DeltaN>
[:SOURce<hw>]:BB:GNSS:SVID<ch>:BEIDou:NMESsage:CNAV:EPHemeris:
  NDELta:UNSCaled <DeltaN>
[:SOURce<hw>]:BB:GNSS:SVID<ch>:BEIDou:NMESsage:CNAV:EPHemeris:
  NDELta <DeltaN>
[:SOURce<hw>]:BB:GNSS:SVID<ch>:BEIDou:NMESsage:DNAV:EPHemeris:
  NDELta:UNSCaled <DeltaN>
[:SOURce<hw>]:BB:GNSS:SVID<ch>:BEIDou:NMESsage:DNAV:EPHemeris:
  NDELta <DeltaN>
[:SOURce<hw>]:BB:GNSS:SVID<ch>:GPS:NMESsage:CNAV:EPHemeris:NDELta:
  UNSCaled <DeltaN>
[:SOURce<hw>]:BB:GNSS:SVID<ch>:GPS:NMESsage:CNAV:EPHemeris:NDELta
  <DeltaN>
[:SOURce<hw>]:BB:GNSS:SVID<ch>:GPS:NMESsage:LNAV:EPHemeris:NDELta:
  UNSCaled <DeltaN>
[:SOURce<hw>]:BB:GNSS:SVID<ch>:GPS:NMESsage:LNAV:EPHemeris:NDELta
  <DeltaN>

```

Sets the mean motion difference delta.

Parameters:

```

<DeltaN>          integer
                  *RST:    0

```

```

[:SOURce<hw>]:BB:GNSS:SVID<ch>:QZSS:NMESsage:CNAV:EPHemeris:DNDot:
  UNSCaled <DeltaNdot>
[:SOURce<hw>]:BB:GNSS:SVID<ch>:QZSS:NMESsage:CNAV:EPHemeris:DNDot
  <DeltaNdot>
[:SOURce<hw>]:BB:GNSS:SVID<ch>:BEIDou:NMESsage:CNAV:EPHemeris:
  DNDot:UNSCaled <DeltaNdot>
[:SOURce<hw>]:BB:GNSS:SVID<ch>:BEIDou:NMESsage:CNAV:EPHemeris:
  DNDot <DeltaNdot>

```

**[:SOURCE<hw>]:BB:GNSS:SVID<ch>:GPS:NMESsage:CNAV:EPHemeris:DNDot:
UNSCaled <DeltaNDot>**

**[:SOURCE<hw>]:BB:GNSS:SVID<ch>:GPS:NMESsage:CNAV:EPHemeris:DNDot
<DeltaNDot>**

Sets the rate of mean motion difference delta.

Parameters:

<DeltaNDot> integer
 *RST: 0

**[:SOURCE<hw>]:BB:GNSS:SVID<ch>:QZSS:NMESsage:CNAV:EPHemeris:ADOT:
UNSCaled <ADot>**

**[:SOURCE<hw>]:BB:GNSS:SVID<ch>:QZSS:NMESsage:CNAV:EPHemeris:ADOT
<ADot>**

**[:SOURCE<hw>]:BB:GNSS:SVID<ch>:BEIDou:NMESsage:CNAV:EPHemeris:
ADOT:UNSCaled <ADot>**

**[:SOURCE<hw>]:BB:GNSS:SVID<ch>:BEIDou:NMESsage:CNAV:EPHemeris:
ADOT <ADot>**

**[:SOURCE<hw>]:BB:GNSS:SVID<ch>:GPS:NMESsage:CNAV:EPHemeris:ADOT:
UNSCaled <ADot>**

**[:SOURCE<hw>]:BB:GNSS:SVID<ch>:GPS:NMESsage:CNAV:EPHemeris:ADOT
<ADot>**

Sets the change rate in semi-major axis.

Parameters:

<ADot> integer
 *RST: 0

**[:SOURCE<hw>]:BB:GNSS:SVID<ch>:QZSS:NMESsage:CNAV:EPHemeris:
ADELta:UNSCaled <DeltaA>**

**[:SOURCE<hw>]:BB:GNSS:SVID<ch>:QZSS:NMESsage:CNAV:EPHemeris:
ADELta <DeltaA>**

**[:SOURCE<hw>]:BB:GNSS:SVID<ch>:BEIDou:NMESsage:CNAV:EPHemeris:
ADELta:UNSCaled <DeltaA>**

**[:SOURCE<hw>]:BB:GNSS:SVID<ch>:BEIDou:NMESsage:CNAV:EPHemeris:
ADELta <DeltaA>**

**[:SOURCE<hw>]:BB:GNSS:SVID<ch>:GPS:NMESsage:CNAV:EPHemeris:ADELta:
UNSCaled <DeltaA>**

**[:SOURCE<hw>]:BB:GNSS:SVID<ch>:GPS:NMESsage:CNAV:EPHemeris:ADELta
<DeltaA>**

Sets the semi-major axis difference.

Parameters:

<DeltaA> integer
 *RST: 0

**[[:SOURCE<hw>]:BB:GNSS:SVID<ch>:GLONass:NMESsage:NAV:EPHemeris:
TINterval?**

Queries the T_b -interval.

Return values:

<TbInterval> string

Usage: Query only

**[[:SOURCE<hw>]:BB:GNSS:SVID<ch>:GLONass:NMESsage:NAV:EPHemeris:
TOE?**

Queries the reference epoch time t_b .

Return values:

<Hour> integer
 Range: 0 to 23

<Minute> integer
 Range: 0 to 59

<Second> float
 Range: 0 to 59
 Increment: 1

Usage: Query only

**[[:SOURCE<hw>]:BB:GNSS:SVID<ch>:GLONass:NMESsage:NAV:EPHemeris:
TINdex:UNSCaled <TbIndex>**

**[[:SOURCE<hw>]:BB:GNSS:SVID<ch>:GLONass:NMESsage:NAV:EPHemeris:
TINdex <TbIndex>**

Sets the t_b Index parameter.

Parameters:

<TbIndex> integer
 *RST: 0

**[[:SOURCE<hw>]:BB:GNSS:SVID<ch>:SBAS:NMESsage:NAV:EPHemeris:ZN:
UNSCaled <Zn>**

[[:SOURCE<hw>]:BB:GNSS:SVID<ch>:SBAS:NMESsage:NAV:EPHemeris:ZN <Zn>

**[[:SOURCE<hw>]:BB:GNSS:SVID<ch>:SBAS:NMESsage:NAV:EPHemeris:YN:
UNSCaled <Yn>**

[[:SOURCE<hw>]:BB:GNSS:SVID<ch>:SBAS:NMESsage:NAV:EPHemeris:YN <Yn>

**[[:SOURCE<hw>]:BB:GNSS:SVID<ch>:SBAS:NMESsage:NAV:EPHemeris:XN:
UNSCaled <Xn>**

[[:SOURCE<hw>]:BB:GNSS:SVID<ch>:SBAS:NMESsage:NAV:EPHemeris:XN <Xn>

**[[:SOURCE<hw>]:BB:GNSS:SVID<ch>:GLONass:NMESsage:NAV:EPHemeris:ZN:
UNSCaled <Zn>**

```

[:SOURce<hw>]:BB:GNSS:SVID<ch>:GLONass:NMESsage:NAV:EPHemeris:ZN
  <Zn>
[:SOURce<hw>]:BB:GNSS:SVID<ch>:GLONass:NMESsage:NAV:EPHemeris:YN:
  UNSCaled <Yn>
[:SOURce<hw>]:BB:GNSS:SVID<ch>:GLONass:NMESsage:NAV:EPHemeris:YN
  <Yn>
[:SOURce<hw>]:BB:GNSS:SVID<ch>:GLONass:NMESsage:NAV:EPHemeris:XN:
  UNSCaled <Xn>
[:SOURce<hw>]:BB:GNSS:SVID<ch>:GLONass:NMESsage:NAV:EPHemeris:XN
  <Xn>

```

Sets the X_n , Y_n and Z_n coordinates in PZ-90.

Parameters:

```

<Xn>                integer
                    *RST:    0

```

```

[:SOURce<hw>]:BB:GNSS:SVID<ch>:SBAS:NMESsage:NAV:EPHemeris:ZDN:
  UNSCaled <ZnDot>
[:SOURce<hw>]:BB:GNSS:SVID<ch>:SBAS:NMESsage:NAV:EPHemeris:ZDN
  <ZnDot>
[:SOURce<hw>]:BB:GNSS:SVID<ch>:SBAS:NMESsage:NAV:EPHemeris:YDN:
  UNSCaled <YnDot>
[:SOURce<hw>]:BB:GNSS:SVID<ch>:SBAS:NMESsage:NAV:EPHemeris:YDN
  <YnDot>
[:SOURce<hw>]:BB:GNSS:SVID<ch>:SBAS:NMESsage:NAV:EPHemeris:XDN:
  UNSCaled <XnDot>
[:SOURce<hw>]:BB:GNSS:SVID<ch>:SBAS:NMESsage:NAV:EPHemeris:XDN
  <XnDot>
[:SOURce<hw>]:BB:GNSS:SVID<ch>:GLONass:NMESsage:NAV:EPHemeris:ZDN:
  UNSCaled <ZnDot>
[:SOURce<hw>]:BB:GNSS:SVID<ch>:GLONass:NMESsage:NAV:EPHemeris:ZDN
  <ZnDot>
[:SOURce<hw>]:BB:GNSS:SVID<ch>:GLONass:NMESsage:NAV:EPHemeris:
  YDN:UNSCaled <YnDot>
[:SOURce<hw>]:BB:GNSS:SVID<ch>:GLONass:NMESsage:NAV:EPHemeris:YDN
  <YnDot>
[:SOURce<hw>]:BB:GNSS:SVID<ch>:GLONass:NMESsage:NAV:EPHemeris:
  XDN:UNSCaled <XnDot>
[:SOURce<hw>]:BB:GNSS:SVID<ch>:GLONass:NMESsage:NAV:EPHemeris:XDN
  <XnDot>

```

Sets the velocity components X'_n , Y'_n and Z'_n .

Parameters:

```

<XnDot>            integer
                    *RST:    0

```

```

[:SOURce<hw>]:BB:GNSS:SVID<ch>:SBAS:NMESsage:NAV:EPHemeris:ZDDN:
  UNSCaLed <ZnDotDot>
[:SOURce<hw>]:BB:GNSS:SVID<ch>:SBAS:NMESsage:NAV:EPHemeris:ZDDN
  <ZnDotDot>
[:SOURce<hw>]:BB:GNSS:SVID<ch>:SBAS:NMESsage:NAV:EPHemeris:YDDN:
  UNSCaLed <YnDotDot>
[:SOURce<hw>]:BB:GNSS:SVID<ch>:SBAS:NMESsage:NAV:EPHemeris:YDDN
  <YnDotDot>
[:SOURce<hw>]:BB:GNSS:SVID<ch>:SBAS:NMESsage:NAV:EPHemeris:XDDN:
  UNSCaLed <XnDotDot>
[:SOURce<hw>]:BB:GNSS:SVID<ch>:SBAS:NMESsage:NAV:EPHemeris:XDDN
  <XnDotDot>
[:SOURce<hw>]:BB:GNSS:SVID<ch>:GLONass:NMESsage:NAV:EPHemeris:
  ZDDN:UNSCaLed <ZnDotDot>
[:SOURce<hw>]:BB:GNSS:SVID<ch>:GLONass:NMESsage:NAV:EPHemeris:
  ZDDN <ZnDotDot>
[:SOURce<hw>]:BB:GNSS:SVID<ch>:GLONass:NMESsage:NAV:EPHemeris:
  YDDN:UNSCaLed <YnDotDot>
[:SOURce<hw>]:BB:GNSS:SVID<ch>:GLONass:NMESsage:NAV:EPHemeris:
  YDDN <YnDotDot>
[:SOURce<hw>]:BB:GNSS:SVID<ch>:GLONass:NMESsage:NAV:EPHemeris:
  XDDN:UNSCaLed <XnDotDot>
[:SOURce<hw>]:BB:GNSS:SVID<ch>:GLONass:NMESsage:NAV:EPHemeris:
  XDDN <XnDotDot>

```

Sets the moon and sun acceleration parameters X''_n , Y''_n and Z''_n .

Parameters:

```

<XnDotDot>          integer
                    *RST:      0

```

```

[:SOURce<hw>]:BB:GNSS:SVID<ch>:NAVic:NMESsage:NAV:EPHemeris:CUC:
  UNSCaLed <Cuc>
[:SOURce<hw>]:BB:GNSS:SVID<ch>:NAVic:NMESsage:NAV:EPHemeris:CUC
  <Cuc>
[:SOURce<hw>]:BB:GNSS:SVID<ch>:QZSS:NMESsage:CNAV:EPHemeris:CUC:
  UNSCaLed <Cuc>
[:SOURce<hw>]:BB:GNSS:SVID<ch>:QZSS:NMESsage:CNAV:EPHemeris:CUC
  <Cuc>
[:SOURce<hw>]:BB:GNSS:SVID<ch>:QZSS:NMESsage:NAV:EPHemeris:CUC:
  UNSCaLed <Cuc>
[:SOURce<hw>]:BB:GNSS:SVID<ch>:QZSS:NMESsage:NAV:EPHemeris:CUC
  <Cuc>
[:SOURce<hw>]:BB:GNSS:SVID<ch>:GALileo:NMESsage:FNAV:EPHemeris:CUC:
  UNSCaLed <Cuc>
[:SOURce<hw>]:BB:GNSS:SVID<ch>:GALileo:NMESsage:FNAV:EPHemeris:CUC
  <Cuc>
[:SOURce<hw>]:BB:GNSS:SVID<ch>:GALileo:NMESsage:INAV:EPHemeris:CUC:
  UNSCaLed <Cuc>

```

```

[:SOURce<hw>]:BB:GNSS:SVID<ch>:GALileo:NMESSage:INAV:EPHemeris:CUC
  <Cuc>
[:SOURce<hw>]:BB:GNSS:SVID<ch>:BEIDou:NMESSage:CNAV:EPHemeris:CUC:
  UNSCaled <Cuc>
[:SOURce<hw>]:BB:GNSS:SVID<ch>:BEIDou:NMESSage:CNAV:EPHemeris:CUC
  <Cuc>
[:SOURce<hw>]:BB:GNSS:SVID<ch>:BEIDou:NMESSage:DNAV:EPHemeris:CUC:
  UNSCaled <Cuc>
[:SOURce<hw>]:BB:GNSS:SVID<ch>:BEIDou:NMESSage:DNAV:EPHemeris:CUC
  <Cuc>
[:SOURce<hw>]:BB:GNSS:SVID<ch>:GPS:NMESSage:CNAV:EPHemeris:CUC:
  UNSCaled <Cuc>
[:SOURce<hw>]:BB:GNSS:SVID<ch>:GPS:NMESSage:CNAV:EPHemeris:CUC
  <Cuc>
[:SOURce<hw>]:BB:GNSS:SVID<ch>:GPS:NMESSage:LNAV:EPHemeris:CUC:
  UNSCaled <Cuc>
[:SOURce<hw>]:BB:GNSS:SVID<ch>:GPS:NMESSage:LNAV:EPHemeris:CUC
  <Cuc>

```

Sets the cosine difference of latitude.

Parameters:

```

<Cuc>          integer
                *RST:    0

```

```

[:SOURce<hw>]:BB:GNSS:SVID<ch>:NAVic:NMESSage:NAV:EPHemeris:CUS:
  UNSCaled <Cus>
[:SOURce<hw>]:BB:GNSS:SVID<ch>:NAVic:NMESSage:NAV:EPHemeris:CUS
  <Cus>
[:SOURce<hw>]:BB:GNSS:SVID<ch>:QZSS:NMESSage:CNAV:EPHemeris:CUS:
  UNSCaled <Cus>
[:SOURce<hw>]:BB:GNSS:SVID<ch>:QZSS:NMESSage:CNAV:EPHemeris:CUS
  <Cus>
[:SOURce<hw>]:BB:GNSS:SVID<ch>:QZSS:NMESSage:NAV:EPHemeris:CUS:
  UNSCaled <Cus>
[:SOURce<hw>]:BB:GNSS:SVID<ch>:QZSS:NMESSage:NAV:EPHemeris:CUS
  <Cus>
[:SOURce<hw>]:BB:GNSS:SVID<ch>:GALileo:NMESSage:FNAV:EPHemeris:CUS:
  UNSCaled <Cus>
[:SOURce<hw>]:BB:GNSS:SVID<ch>:GALileo:NMESSage:FNAV:EPHemeris:CUS
  <Cus>
[:SOURce<hw>]:BB:GNSS:SVID<ch>:GALileo:NMESSage:INAV:EPHemeris:CUS:
  UNSCaled <Cus>
[:SOURce<hw>]:BB:GNSS:SVID<ch>:GALileo:NMESSage:INAV:EPHemeris:CUS
  <Cus>
[:SOURce<hw>]:BB:GNSS:SVID<ch>:BEIDou:NMESSage:CNAV:EPHemeris:CUS:
  UNSCaled <Cus>
[:SOURce<hw>]:BB:GNSS:SVID<ch>:BEIDou:NMESSage:CNAV:EPHemeris:CUS
  <Cus>

```

```

[:SOURce<hw>]:BB:GNSS:SVID<ch>:BEIDou:NMESsage:DNAV:EPHemeris:CUS
  <Cus>
[:SOURce<hw>]:BB:GNSS:SVID<ch>:BEIDou:NMESsage:DNAV:EPHemeris:CUS:
  UNSCaled <Cus>
[:SOURce<hw>]:BB:GNSS:SVID<ch>:GPS:NMESsage:CNAV:EPHemeris:CUS:
  UNSCaled <Cus>
[:SOURce<hw>]:BB:GNSS:SVID<ch>:GPS:NMESsage:CNAV:EPHemeris:CUS
  <Cus>
[:SOURce<hw>]:BB:GNSS:SVID<ch>:GPS:NMESsage:LNAV:EPHemeris:CUS:
  UNSCaled <Cus>
[:SOURce<hw>]:BB:GNSS:SVID<ch>:GPS:NMESsage:LNAV:EPHemeris:CUS
  <Cus>

```

Sets the sine difference of latitude.

Parameters:

```

<Cus>          integer
                *RST:    0

```

```

[:SOURce<hw>]:BB:GNSS:SVID<ch>:NAVic:NMESsage:NAV:EPHemeris:CRc:
  UNSCaled <Crc>
[:SOURce<hw>]:BB:GNSS:SVID<ch>:NAVic:NMESsage:NAV:EPHemeris:CRc
  <Crc>
[:SOURce<hw>]:BB:GNSS:SVID<ch>:QZSS:NMESsage:CNAV:EPHemeris:CRc:
  UNSCaled <Crc>
[:SOURce<hw>]:BB:GNSS:SVID<ch>:QZSS:NMESsage:CNAV:EPHemeris:CRc
  <Crc>
[:SOURce<hw>]:BB:GNSS:SVID<ch>:QZSS:NMESsage:NAV:EPHemeris:CRc:
  UNSCaled <Crc>
[:SOURce<hw>]:BB:GNSS:SVID<ch>:QZSS:NMESsage:NAV:EPHemeris:CRc
  <Crc>
[:SOURce<hw>]:BB:GNSS:SVID<ch>:GALileo:NMESsage:FNAV:EPHemeris:CRc:
  UNSCaled <Crc>
[:SOURce<hw>]:BB:GNSS:SVID<ch>:GALileo:NMESsage:FNAV:EPHemeris:CRc
  <Crc>
[:SOURce<hw>]:BB:GNSS:SVID<ch>:GALileo:NMESsage:INAV:EPHemeris:CRc:
  UNSCaled <Crc>
[:SOURce<hw>]:BB:GNSS:SVID<ch>:GALileo:NMESsage:INAV:EPHemeris:CRc
  <Crc>
[:SOURce<hw>]:BB:GNSS:SVID<ch>:BEIDou:NMESsage:CNAV:EPHemeris:CRc:
  UNSCaled <Crc>
[:SOURce<hw>]:BB:GNSS:SVID<ch>:BEIDou:NMESsage:CNAV:EPHemeris:CRc
  <Crc>
[:SOURce<hw>]:BB:GNSS:SVID<ch>:BEIDou:NMESsage:DNAV:EPHemeris:CRc:
  UNSCaled <Crc>
[:SOURce<hw>]:BB:GNSS:SVID<ch>:BEIDou:NMESsage:DNAV:EPHemeris:CRc
  <Crc>
[:SOURce<hw>]:BB:GNSS:SVID<ch>:GPS:NMESsage:CNAV:EPHemeris:CRc:
  UNSCaled <Crc>

```

**[:SOURce<hw>]:BB:GNSS:SVID<ch>:GPS:NMESsage:CNAV:EPHemeris:CRS
<Crc>**

**[:SOURce<hw>]:BB:GNSS:SVID<ch>:GPS:NMESsage:LNAV:EPHemeris:CRS:
UNSCaled <Crc>**

**[:SOURce<hw>]:BB:GNSS:SVID<ch>:GPS:NMESsage:LNAV:EPHemeris:CRS
<Crc>**

Sets the cosine difference of orbital radius.

Parameters:

<Crc> integer
*RST: 0

**[:SOURce<hw>]:BB:GNSS:SVID<ch>:NAVic:NMESsage:NAV:EPHemeris:CRS:
UNSCaled <Crs>**

**[:SOURce<hw>]:BB:GNSS:SVID<ch>:NAVic:NMESsage:NAV:EPHemeris:CRS
<Crs>**

**[:SOURce<hw>]:BB:GNSS:SVID<ch>:QZSS:NMESsage:CNAV:EPHemeris:CRS:
UNSCaled <Crs>**

**[:SOURce<hw>]:BB:GNSS:SVID<ch>:QZSS:NMESsage:CNAV:EPHemeris:CRS
<Crs>**

**[:SOURce<hw>]:BB:GNSS:SVID<ch>:QZSS:NMESsage:NAV:EPHemeris:CRS:
UNSCaled <Crs>**

**[:SOURce<hw>]:BB:GNSS:SVID<ch>:QZSS:NMESsage:NAV:EPHemeris:CRS
<Crs>**

**[:SOURce<hw>]:BB:GNSS:SVID<ch>:GALileo:NMESsage:FNAV:EPHemeris:CRS:
UNSCaled <Crs>**

**[:SOURce<hw>]:BB:GNSS:SVID<ch>:GALileo:NMESsage:FNAV:EPHemeris:CRS
<Crs>**

**[:SOURce<hw>]:BB:GNSS:SVID<ch>:GALileo:NMESsage:INAV:EPHemeris:CRS:
UNSCaled <Crs>**

**[:SOURce<hw>]:BB:GNSS:SVID<ch>:GALileo:NMESsage:INAV:EPHemeris:CRS
<Crs>**

**[:SOURce<hw>]:BB:GNSS:SVID<ch>:BEIDou:NMESsage:CNAV:EPHemeris:CRS:
UNSCaled <Crs>**

**[:SOURce<hw>]:BB:GNSS:SVID<ch>:BEIDou:NMESsage:CNAV:EPHemeris:CRS
<Crs>**

**[:SOURce<hw>]:BB:GNSS:SVID<ch>:BEIDou:NMESsage:DNAV:EPHemeris:CRS:
UNSCaled <Crs>**

**[:SOURce<hw>]:BB:GNSS:SVID<ch>:BEIDou:NMESsage:DNAV:EPHemeris:CRS
<Crs>**

**[:SOURce<hw>]:BB:GNSS:SVID<ch>:GPS:NMESsage:CNAV:EPHemeris:CRS:
UNSCaled <Crs>**

**[:SOURce<hw>]:BB:GNSS:SVID<ch>:GPS:NMESsage:CNAV:EPHemeris:CRS
<Crs>**

**[:SOURCE<hw>]:BB:GNSS:SVID<ch>:GPS:NMESsage:LNAV:EPHemeris:CRS:
UNSCaled <Crs>**

**[:SOURCE<hw>]:BB:GNSS:SVID<ch>:GPS:NMESsage:LNAV:EPHemeris:CRS
<Crs>**

Sets the sine difference of orbital radius.

Parameters:

<Crs> integer
*RST: 0

**[:SOURCE<hw>]:BB:GNSS:SVID<ch>:NAVic:NMESsage:NAV:EPHemeris:CIC:
UNSCaled <Cic>**

**[:SOURCE<hw>]:BB:GNSS:SVID<ch>:NAVic:NMESsage:NAV:EPHemeris:CIC
<Cic>**

**[:SOURCE<hw>]:BB:GNSS:SVID<ch>:QZSS:NMESsage:CNAV:EPHemeris:CIC:
UNSCaled <Cic>**

**[:SOURCE<hw>]:BB:GNSS:SVID<ch>:QZSS:NMESsage:CNAV:EPHemeris:CIC
<Cic>**

**[:SOURCE<hw>]:BB:GNSS:SVID<ch>:QZSS:NMESsage:NAV:EPHemeris:CIC:
UNSCaled <Cic>**

**[:SOURCE<hw>]:BB:GNSS:SVID<ch>:QZSS:NMESsage:NAV:EPHemeris:CIC
<Cic>**

**[:SOURCE<hw>]:BB:GNSS:SVID<ch>:GALileo:NMESsage:FNAV:EPHemeris:CIC:
UNSCaled <Cic>**

**[:SOURCE<hw>]:BB:GNSS:SVID<ch>:GALileo:NMESsage:FNAV:EPHemeris:CIC
<Cic>**

**[:SOURCE<hw>]:BB:GNSS:SVID<ch>:GALileo:NMESsage:INAV:EPHemeris:CIC:
UNSCaled <Cic>**

**[:SOURCE<hw>]:BB:GNSS:SVID<ch>:GALileo:NMESsage:INAV:EPHemeris:CIC
<Cic>**

**[:SOURCE<hw>]:BB:GNSS:SVID<ch>:BEIDou:NMESsage:CNAV:EPHemeris:CIC:
UNSCaled <Cic>**

**[:SOURCE<hw>]:BB:GNSS:SVID<ch>:BEIDou:NMESsage:CNAV:EPHemeris:CIC
<Cic>**

**[:SOURCE<hw>]:BB:GNSS:SVID<ch>:BEIDou:NMESsage:DNAV:EPHemeris:CIC:
UNSCaled <Cic>**

**[:SOURCE<hw>]:BB:GNSS:SVID<ch>:BEIDou:NMESsage:DNAV:EPHemeris:CIC
<Cic>**

**[:SOURCE<hw>]:BB:GNSS:SVID<ch>:GPS:NMESsage:CNAV:EPHemeris:CIC:
UNSCaled <Cic>**

**[:SOURCE<hw>]:BB:GNSS:SVID<ch>:GPS:NMESsage:CNAV:EPHemeris:CIC
<Cic>**

**[:SOURCE<hw>]:BB:GNSS:SVID<ch>:GPS:NMESsage:LNAV:EPHemeris:CIC:
UNSCaled <Cic>**

**[:SOURCE<hw>]:BB:GNSS:SVID<ch>:GPS:NMESsage:LNAV:EPHemeris:CIC
<Cic>**

Sets the sine difference of orbital radius.

Parameters:

<Cic> integer
 *RST: 0

[:SOURce<hw>]:BB:GNSS:SVID<ch>:NAVic:NMESsage:NAV:EPHemeris:CIS:
 UNSCaled <Cis>
 [:SOURce<hw>]:BB:GNSS:SVID<ch>:NAVic:NMESsage:NAV:EPHemeris:CIS
 <Cis>
 [:SOURce<hw>]:BB:GNSS:SVID<ch>:QZSS:NMESsage:CNAV:EPHemeris:CIS:
 UNSCaled <Cis>
 [:SOURce<hw>]:BB:GNSS:SVID<ch>:QZSS:NMESsage:CNAV:EPHemeris:CIS
 <Cis>
 [:SOURce<hw>]:BB:GNSS:SVID<ch>:QZSS:NMESsage:NAV:EPHemeris:CIS:
 UNSCaled <Cis>
 [:SOURce<hw>]:BB:GNSS:SVID<ch>:QZSS:NMESsage:NAV:EPHemeris:CIS
 <Cis>
 [:SOURce<hw>]:BB:GNSS:SVID<ch>:GALileo:NMESsage:FNAV:EPHemeris:CIS:
 UNSCaled <Cis>
 [:SOURce<hw>]:BB:GNSS:SVID<ch>:GALileo:NMESsage:FNAV:EPHemeris:CIS
 <Cis>
 [:SOURce<hw>]:BB:GNSS:SVID<ch>:GALileo:NMESsage:INAV:EPHemeris:CIS:
 UNSCaled <Cis>
 [:SOURce<hw>]:BB:GNSS:SVID<ch>:GALileo:NMESsage:INAV:EPHemeris:CIS
 <Cis>
 [:SOURce<hw>]:BB:GNSS:SVID<ch>:BEIDou:NMESsage:CNAV:EPHemeris:CIS:
 UNSCaled <Cis>
 [:SOURce<hw>]:BB:GNSS:SVID<ch>:BEIDou:NMESsage:CNAV:EPHemeris:CIS
 <Cis>
 [:SOURce<hw>]:BB:GNSS:SVID<ch>:BEIDou:NMESsage:DNAV:EPHemeris:CIS:
 UNSCaled <Cis>
 [:SOURce<hw>]:BB:GNSS:SVID<ch>:BEIDou:NMESsage:DNAV:EPHemeris:CIS
 <Cis>
 [:SOURce<hw>]:BB:GNSS:SVID<ch>:GPS:NMESsage:CNAV:EPHemeris:CIS:
 UNSCaled <Cis>
 [:SOURce<hw>]:BB:GNSS:SVID<ch>:GPS:NMESsage:CNAV:EPHemeris:CIS
 <Cis>
 [:SOURce<hw>]:BB:GNSS:SVID<ch>:GPS:NMESsage:LNAV:EPHemeris:CIS:
 UNSCaled <Cis>
 [:SOURce<hw>]:BB:GNSS:SVID<ch>:GPS:NMESsage:LNAV:EPHemeris:CIS
 <Cis>

Sets the sine difference of inclination.

Parameters:

<Cis> integer
 *RST: 0

```
[:SOURce<hw>]:BB:GNSS:SVID<ch>:QZSS:NMESsage:NAV:EPHemeris:IODC
<lodc>
[:SOURce<hw>]:BB:GNSS:SVID<ch>:BEIDou:NMESsage:DNAV:EPHemeris:IODC
<lodc>
[:SOURce<hw>]:BB:GNSS:SVID<ch>:GPS:NMESsage:LNAV:EPHemeris:IODC
<lodc>
```

Sets the issue of data, clock (IODC).

Parameters:

```
<lodc>                integer
                        Range:    0 to 1023
                        *RST:    0
```

```
[:SOURce<hw>]:BB:GNSS:SVID<ch>:NAVic:NMESsage:NAV:CCORrection:TOC:
UNSCaled <Toc>
[:SOURce<hw>]:BB:GNSS:SVID<ch>:NAVic:NMESsage:NAV:CCORrection:TOC
<Toc>
[:SOURce<hw>]:BB:GNSS:SVID<ch>:QZSS:NMESsage:CNAV:CCORrection:TOC:
UNSCaled <Toc>
[:SOURce<hw>]:BB:GNSS:SVID<ch>:QZSS:NMESsage:CNAV:CCORrection:TOC
<Toc>
[:SOURce<hw>]:BB:GNSS:SVID<ch>:QZSS:NMESsage:NAV:CCORrection:TOC:
UNSCaled <Toc>
[:SOURce<hw>]:BB:GNSS:SVID<ch>:QZSS:NMESsage:NAV:CCORrection:TOC
<Toc>
[:SOURce<hw>]:BB:GNSS:SVID<ch>:GALileo:NMESsage:FNAV:CCORrection:
TOC:UNSCaled <Toc>
[:SOURce<hw>]:BB:GNSS:SVID<ch>:GALileo:NMESsage:FNAV:CCORrection:
TOC <Toc>
[:SOURce<hw>]:BB:GNSS:SVID<ch>:GALileo:NMESsage:INAV:CCORrection:
TOC:UNSCaled <Toc>
[:SOURce<hw>]:BB:GNSS:SVID<ch>:GALileo:NMESsage:INAV:CCORrection:
TOC <Toc>
[:SOURce<hw>]:BB:GNSS:SVID<ch>:BEIDou:NMESsage:CNAV:CCORrection:
TOC:UNSCaled <Toc>
[:SOURce<hw>]:BB:GNSS:SVID<ch>:BEIDou:NMESsage:CNAV:CCORrection:
TOC <Toc>
[:SOURce<hw>]:BB:GNSS:SVID<ch>:BEIDou:NMESsage:DNAV:CCORrection:
TOC:UNSCaled <Toc>
[:SOURce<hw>]:BB:GNSS:SVID<ch>:BEIDou:NMESsage:DNAV:CCORrection:
TOC <Toc>
[:SOURce<hw>]:BB:GNSS:SVID<ch>:GPS:NMESsage:CNAV:CCORrection:TOC:
UNSCaled <Toc>
[:SOURce<hw>]:BB:GNSS:SVID<ch>:GPS:NMESsage:CNAV:CCORrection:TOC
<Toc>
```

[:SOURCE<hw>]:BB:GNSS:SVID<ch>:GPS:NMESsage:LNAV:CCORrection:TOC:UNSCaled <Toc>

[:SOURCE<hw>]:BB:GNSS:SVID<ch>:GPS:NMESsage:LNAV:CCORrection:TOC <Toc>

Sets the reference time of clock.

Parameters:

<Toc> integer
*RST: 0

[:SOURCE<hw>]:BB:GNSS:SVID<ch>:SBAS:NMESsage:NAV:CCORrection:AF<s2us0> <Af>

[:SOURCE<hw>]:BB:GNSS:SVID<ch>:SBAS:NMESsage:NAV:CCORrection:AF<s2us0>:UNSCaled <Af>

[:SOURCE<hw>]:BB:GNSS:SVID<ch>:NAVic:NMESsage:NAV:CCORrection:AF<s2us0>:UNSCaled <Af>

[:SOURCE<hw>]:BB:GNSS:SVID<ch>:NAVic:NMESsage:NAV:CCORrection:AF<s2us0> <Af>

[:SOURCE<hw>]:BB:GNSS:SVID<ch>:QZSS:NMESsage:CNAV:CCORrection:AF<s2us0>:UNSCaled <Af>

[:SOURCE<hw>]:BB:GNSS:SVID<ch>:QZSS:NMESsage:CNAV:CCORrection:AF<s2us0> <Af>

[:SOURCE<hw>]:BB:GNSS:SVID<ch>:QZSS:NMESsage:NAV:CCORrection:AF<s2us0>:UNSCaled <Af>

[:SOURCE<hw>]:BB:GNSS:SVID<ch>:QZSS:NMESsage:NAV:CCORrection:AF<s2us0> <Af>

[:SOURCE<hw>]:BB:GNSS:SVID<ch>:GALileo:NMESsage:FNAV:CCORrection:AF<s2us0>:UNSCaled <Af>

[:SOURCE<hw>]:BB:GNSS:SVID<ch>:GALileo:NMESsage:FNAV:CCORrection:AF<s2us0> <Af>

[:SOURCE<hw>]:BB:GNSS:SVID<ch>:GALileo:NMESsage:INAV:CCORrection:AF<s2us0>:UNSCaled <Af>

[:SOURCE<hw>]:BB:GNSS:SVID<ch>:GALileo:NMESsage:INAV:CCORrection:AF<s2us0> <Af>

[:SOURCE<hw>]:BB:GNSS:SVID<ch>:BEIDou:NMESsage:CNAV:CCORrection:AF<s2us0>:UNSCaled <Af>

[:SOURCE<hw>]:BB:GNSS:SVID<ch>:BEIDou:NMESsage:CNAV:CCORrection:AF<s2us0> <Af>

[:SOURCE<hw>]:BB:GNSS:SVID<ch>:BEIDou:NMESsage:DNAV:CCORrection:AF<s2us0>:UNSCaled <Af>

[:SOURCE<hw>]:BB:GNSS:SVID<ch>:BEIDou:NMESsage:DNAV:CCORrection:AF<s2us0> <Af>

[:SOURCE<hw>]:BB:GNSS:SVID<ch>:GPS:NMESsage:CNAV:CCORrection:AF<s2us0>:UNSCaled <Af>

[:SOURCE<hw>]:BB:GNSS:SVID<ch>:GPS:NMESsage:CNAV:CCORrection:AF<s2us0> <Af>

**[:SOURCE<hw>]:BB:GNSS:SVID<ch>:GPS:NMESSage:LNAV:CCORrection:
AF<s2us0>:UNSCaled <Af>**

**[:SOURCE<hw>]:BB:GNSS:SVID<ch>:GPS:NMESSage:LNAV:CCORrection:
AF<s2us0> <Af>**

Sets the parameter AF 0 to 2.

Suffix:

AF<s2us0> 0 to 2 (GPS, Galileo, BeiDou, QZSS) | 0 to 1 (SBAS)

Parameters:

<Af> integer
*RST: 0

**[:SOURCE<hw>]:BB:GNSS:SVID<ch>:NAVic:NMESSage:NAV:CCORrection:TGD:
UNSCaled <Tgd>**

**[:SOURCE<hw>]:BB:GNSS:SVID<ch>:NAVic:NMESSage:NAV:CCORrection:TGD
<Tgd>**

**[:SOURCE<hw>]:BB:GNSS:SVID<ch>:QZSS:NMESSage:CNAV:CCORrection:TGD:
UNSCaled <Tgd>**

**[:SOURCE<hw>]:BB:GNSS:SVID<ch>:QZSS:NMESSage:CNAV:CCORrection:TGD
<Tgd>**

**[:SOURCE<hw>]:BB:GNSS:SVID<ch>:QZSS:NMESSage:NAV:CCORrection:TGD:
UNSCaled <Tgd>**

**[:SOURCE<hw>]:BB:GNSS:SVID<ch>:QZSS:NMESSage:NAV:CCORrection:TGD
<Tgd>**

**[:SOURCE<hw>]:BB:GNSS:SVID<ch>:BEIDou:NMESSage:CNAV:CCORrection:
TGD:UNSCaled <Tgd>**

**[:SOURCE<hw>]:BB:GNSS:SVID<ch>:BEIDou:NMESSage:CNAV:CCORrection:
TGD <Tgd>**

**[:SOURCE<hw>]:BB:GNSS:SVID<ch>:BEIDou:NMESSage:DNAV:CCORrection:
TGD<s2us>:UNSCaled <Tgd>**

**[:SOURCE<hw>]:BB:GNSS:SVID<ch>:BEIDou:NMESSage:DNAV:CCORrection:
TGD<s2us> <Tgd>**

**[:SOURCE<hw>]:BB:GNSS:SVID<ch>:GPS:NMESSage:CNAV:CCORrection:TGD:
UNSCaled <Tgd>**

**[:SOURCE<hw>]:BB:GNSS:SVID<ch>:GPS:NMESSage:CNAV:CCORrection:TGD
<Tgd>**

**[:SOURCE<hw>]:BB:GNSS:SVID<ch>:GPS:NMESSage:LNAV:CCORrection:TGD:
UNSCaled <Tgd>**

**[:SOURCE<hw>]:BB:GNSS:SVID<ch>:GPS:NMESSage:LNAV:CCORrection:TGD
<Tgd>**

Sets the group delay.

Parameters:

<Tgd> integer
Range: -128 to 127
*RST: 0

```

[:SOURce<hw>]:BB:GNSS:SVID<ch>:QZSS:NMESsage:CNAV:CCORrection:ISC:
  L5Q:UNSCaled <IscL5Q5>
[:SOURce<hw>]:BB:GNSS:SVID<ch>:QZSS:NMESsage:CNAV:CCORrection:ISC:
  L5Q <IscL5Q5>
[:SOURce<hw>]:BB:GNSS:SVID<ch>:QZSS:NMESsage:CNAV:CCORrection:ISC:
  L5I:UNSCaled <IscL5I5>
[:SOURce<hw>]:BB:GNSS:SVID<ch>:QZSS:NMESsage:CNAV:CCORrection:ISC:
  L5I <IscL5I5>
[:SOURce<hw>]:BB:GNSS:SVID<ch>:QZSS:NMESsage:CNAV:CCORrection:ISC:
  L2C:UNSCaled <IscL2C>
[:SOURce<hw>]:BB:GNSS:SVID<ch>:QZSS:NMESsage:CNAV:CCORrection:ISC:
  L2C <IscL2C>
[:SOURce<hw>]:BB:GNSS:SVID<ch>:QZSS:NMESsage:CNAV:CCORrection:ISC:
  L1CA:UNSCaled <IscL1CA>
[:SOURce<hw>]:BB:GNSS:SVID<ch>:QZSS:NMESsage:CNAV:CCORrection:ISC:
  L1CA <IscL1CA>
[:SOURce<hw>]:BB:GNSS:SVID<ch>:GPS:NMESsage:CNAV:CCORrection:ISC:
  L5Q:UNSCaled <IscL5Q5>
[:SOURce<hw>]:BB:GNSS:SVID<ch>:GPS:NMESsage:CNAV:CCORrection:ISC:
  L5Q <IscL5Q5>
[:SOURce<hw>]:BB:GNSS:SVID<ch>:GPS:NMESsage:CNAV:CCORrection:ISC:
  L5I:UNSCaled <IscL5I5>
[:SOURce<hw>]:BB:GNSS:SVID<ch>:GPS:NMESsage:CNAV:CCORrection:ISC:L5I
  <IscL5I5>
[:SOURce<hw>]:BB:GNSS:SVID<ch>:GPS:NMESsage:CNAV:CCORrection:ISC:
  L2C:UNSCaled <IscL2C>
[:SOURce<hw>]:BB:GNSS:SVID<ch>:GPS:NMESsage:CNAV:CCORrection:ISC:
  L2C <IscL2C>
[:SOURce<hw>]:BB:GNSS:SVID<ch>:GPS:NMESsage:CNAV:CCORrection:ISC:
  L1CA:UNSCaled <IscL1CA>
[:SOURce<hw>]:BB:GNSS:SVID<ch>:GPS:NMESsage:CNAV:CCORrection:ISC:
  L1CA <IscL1CA>

```

Sets the inter-signal corrections (ISC) parameters of the GPS/QZSS CNAV message.

Parameters:

```

<IscL1CA>          integer
                   Range:    -4096 to 4095
                   *RST:     0

```

```

[:SOURce<hw>]:BB:GNSS:SVID<ch>:GALileo:NMESsage:FNAV:CCORrection:
  BGDA:UNSCaled <Bgd>
[:SOURce<hw>]:BB:GNSS:SVID<ch>:GALileo:NMESsage:FNAV:CCORrection:
  BGDA <Bgd>
[:SOURce<hw>]:BB:GNSS:SVID<ch>:GALileo:NMESsage:INAV:CCORrection:
  BGDB:UNSCaled <Tgd>
[:SOURce<hw>]:BB:GNSS:SVID<ch>:GALileo:NMESsage:INAV:CCORrection:
  BGDB <Tgd>

```

**[[:SOURce<hw>]:BB:GNSS:SVID<ch>:GALileo:NMESsage:INAV:CCORrection:
BGDA:UNSCaled <Bgd>**

**[[:SOURce<hw>]:BB:GNSS:SVID<ch>:GALileo:NMESsage:INAV:CCORrection:
BGDA <Bgd>**

Sets the broadcast group delay.

Parameters:

<Bgd> integer
Range: -512 to 511
*RST: 0

**[[:SOURce<hw>]:BB:GNSS:SVID<ch>:GLONass:NMESsage:NAV:CCORrection:
TAUN:UNSCaled <Tau>**

**[[:SOURce<hw>]:BB:GNSS:SVID<ch>:GLONass:NMESsage:NAV:CCORrection:
TAUN <Tau>**

Sets the parameter T_n ($\sim -a_{f0}$)

Parameters:

<Tau> integer
*RST: 0

**[[:SOURce<hw>]:BB:GNSS:SVID<ch>:GLONass:NMESsage:NAV:CCORrection:
GAMN:UNSCaled <GammaN>**

**[[:SOURce<hw>]:BB:GNSS:SVID<ch>:GLONass:NMESsage:NAV:CCORrection:
GAMN <GammaN>**

Sets the parameter Γ_n ($\sim a_{f1}$).

Parameters:

<GammaN> integer
*RST: 0

**[[:SOURce<hw>]:BB:GNSS:SVID<ch>:GLONass:NMESsage:NAV:CCORrection:
DTAU:UNSCaled <Tgd>**

**[[:SOURce<hw>]:BB:GNSS:SVID<ch>:GLONass:NMESsage:NAV:CCORrection:
DTAU <Tgd>**

Sets the DELTA T_n ($\sim T_{gd}$).

Parameters:

<Tgd> integer
Range: -128 to 127
*RST: 0

```
[ :SOURce<hw>]:BB:GNSS:SVID<ch>:QZSS:NMESsage:CNAV:EPHemeris:ALERTt
<AlertFlag>
```

```
[ :SOURce<hw>]:BB:GNSS:SVID<ch>:BEIDou:NMESsage:CNAV:EPHemeris:
ALERTt <AlertFlag>
```

```
[ :SOURce<hw>]:BB:GNSS:SVID<ch>:GPS:NMESsage:CNAV:EPHemeris:ALERTt
<AlertFlag>
```

Sets the alert flag.

Parameters:

```
<AlertFlag>          1 | ON | 0 | OFF
*RST:                0
```

```
[ :SOURce<hw>]:BB:GNSS:SVID<ch>:QZSS:NMESsage:CNAV:EPHemeris:
L5Health <L5Health>
```

```
[ :SOURce<hw>]:BB:GNSS:SVID<ch>:QZSS:NMESsage:CNAV:EPHemeris:
L2Health <L2Health>
```

```
[ :SOURce<hw>]:BB:GNSS:SVID<ch>:QZSS:NMESsage:CNAV:EPHemeris:
L1Health <L1Health>
```

```
[ :SOURce<hw>]:BB:GNSS:SVID<ch>:GPS:NMESsage:CNAV:EPHemeris:
L5Health <L5Health>
```

```
[ :SOURce<hw>]:BB:GNSS:SVID<ch>:GPS:NMESsage:CNAV:EPHemeris:
L2Health <L2Health>
```

```
[ :SOURce<hw>]:BB:GNSS:SVID<ch>:GPS:NMESsage:CNAV:EPHemeris:
L1Health <L1Health>
```

Sets the L1, L2 or L5 health flag in the GPS/QZSS CNAV message.

Parameters:

```
<L1Health>          integer
Range:              0 to 1
*RST:                0
```

```
[ :SOURce<hw>]:BB:GNSS:SVID<ch>:QZSS:NMESsage:CNAV:EPHemeris:NED0
<NED0>
```

```
[ :SOURce<hw>]:BB:GNSS:SVID<ch>:QZSS:NMESsage:CNAV:EPHemeris:NED1
<NED1>
```

```
[ :SOURce<hw>]:BB:GNSS:SVID<ch>:QZSS:NMESsage:CNAV:EPHemeris:NED2
<NED0>
```

```
[ :SOURce<hw>]:BB:GNSS:SVID<ch>:GPS:NMESsage:CNAV:EPHemeris:NED0
<NED0>
```

```
[ :SOURce<hw>]:BB:GNSS:SVID<ch>:GPS:NMESsage:CNAV:EPHemeris:NED1
<NED1>
```

```
[ :SOURce<hw>]:BB:GNSS:SVID<ch>:GPS:NMESsage:CNAV:EPHemeris:NED2
<NED0>
```

Sets the NED accuracy index (*NED0*), accuracy change index (*NED1*) and accuracy change rate index (*NED2*).

Parameters:

<NED0> integer
 Range: 0 to 7
 *RST: 0

**[[:SOURce<hw>]:BB:GNSS:SVID<ch>:GPS:NMESsage:CNAV:EPHemeris:WNOP
 <WNOP>**

Sets the data predict week number.

Parameters:

<WNOP> integer
 Range: 0 to 8191
 *RST: 0

**[[:SOURce<hw>]:BB:GNSS:SVID<ch>:GPS:NMESsage:CNAV:EPHemeris:TOP:
 UNSCaled <Top>**
**[[:SOURce<hw>]:BB:GNSS:SVID<ch>:GPS:NMESsage:CNAV:EPHemeris:TOP
 <Top>**

Sets the data predict time of week.

Parameters:

<Top> integer
 *RST: 0

**[[:SOURce<hw>]:BB:GNSS:SVID<ch>:QZSS:NMESsage:CNAV:EPHemeris:ISFLag
 <IsFlag>**
**[[:SOURce<hw>]:BB:GNSS:SVID<ch>:GPS:NMESsage:CNAV:EPHemeris:ISFLag
 <IsFlag>**

Sets the integrity status flag.

Parameters:

<IsFlag> 1 | ON | 0 | OFF
 *RST: 0

**[[:SOURce<hw>]:BB:GNSS:SVID<ch>:QZSS:NMESsage:CNAV:EPHemeris:
 L2CPhasing <L2CPhasing>**
**[[:SOURce<hw>]:BB:GNSS:SVID<ch>:GPS:NMESsage:CNAV:EPHemeris:
 L2CPhasing <L2CPhasing>**

Sets the L2C phasing.

Parameters:

<L2CPhasing> 1 | ON | 0 | OFF
 *RST: 0

**[:SOURce<hw>]:BB:GNSS:SVID<ch>:NAVic:NMESsage:NAV:EPHemeris:
L5Health <L5Health>**

Sets the L5 health flag in the NavIC NAV message.

Parameters:

<L5Health> integer
 Range: 0 to 1
 *RST: 0

**[:SOURce<hw>]:BB:GNSS:SVID<ch>:NAVic:NMESsage:NAV:EPHemeris:SHealth
<SHealth>**

Sets the S health flag in the NavIC NAV message.

Parameters:

<SHealth> integer
 Range: 0 to 1
 *RST: 0

**[:SOURce<hw>]:BB:GNSS:SVID<ch>:QZSS:NMESsage:NAV:EPHemeris:HEALth
<SvHealt>**

**[:SOURce<hw>]:BB:GNSS:SVID<ch>:GLONass:NMESsage:NAV:EPHemeris:
HEALth <SvHealt>**

**[:SOURce<hw>]:BB:GNSS:SVID<ch>:BEIDou:NMESsage:DNAV:EPHemeris:
HEALth <SvHealt>**

**[:SOURce<hw>]:BB:GNSS:SVID<ch>:GPS:NMESsage:LNAV:EPHemeris:HEALth
<SvHealt>**

Sets the SV health.

See also [\[:SOURce<hw>\]:BB:GNSS:SVID<ch>:GPS:HEALthy](#) on page 445.

Parameters:

<SvHealt> integer
 Range: 0 to 63
 *RST: 0

**[:SOURce<hw>]:BB:GNSS:SVID<ch>:SBAS:NMESsage:NAV:EPHemeris:URA
<URA>**

**[:SOURce<hw>]:BB:GNSS:SVID<ch>:NAVic:NMESsage:NAV:EPHemeris:URA
<URA>**

**[:SOURce<hw>]:BB:GNSS:SVID<ch>:QZSS:NMESsage:CNAV:EPHemeris:URA
<URA>**

**[:SOURce<hw>]:BB:GNSS:SVID<ch>:QZSS:NMESsage:NAV:EPHemeris:URA
<URA>**

**[:SOURce<hw>]:BB:GNSS:SVID<ch>:GLONass:NMESsage:NAV:EPHemeris:URA
<URA>**

[:SOURCE<hw>]:BB:GNSS:SVID<ch>:BEIDou:NMESsage:DNAV:EPHemeris:URA
 <URA>

[:SOURCE<hw>]:BB:GNSS:SVID<ch>:GPS:NMESsage:CNAV:EPHemeris:URA
 <URA>

[:SOURCE<hw>]:BB:GNSS:SVID<ch>:GPS:NMESsage:LNAV:EPHemeris:URA
 <URA>

Sets the user range accuracy index.

Parameters:

<URA> integer
 Range: 0 to 15
 *RST: 5

[:SOURCE<hw>]:BB:GNSS:SVID<ch>:GPS:NMESsage:LNAV:EPHemeris:ASFLag
 <AntiSpoofFlag>

Parameters:

<AntiSpoofFlag> 1 | ON | 0 | OFF
 *RST: 0

[:SOURCE<hw>]:BB:GNSS:SVID<ch>:QZSS:NMESsage:NAV:EPHemeris:
SVConfig <AsFlag>

[:SOURCE<hw>]:BB:GNSS:SVID<ch>:GPS:NMESsage:LNAV:EPHemeris:
SVConfig <AsFlag>

Sets the SV config.

Parameters:

<AsFlag> integer
 Range: 0 to 7
 *RST: 0

[:SOURCE<hw>]:BB:GNSS:SVID<ch>:QZSS:NMESsage:NAV:EPHemeris:
CLTMode <CodeOnL2Mode>

[:SOURCE<hw>]:BB:GNSS:SVID<ch>:GPS:NMESsage:LNAV:EPHemeris:
CLTMode <CodeOnL2Mode>

Sets the code on L2.

Parameters:

<CodeOnL2Mode> REServed | PCODE | CACode
 *RST: PCODE

[:SOURCE<hw>]:BB:GNSS:SVID<ch>:QZSS:NMESsage:NAV:EPHemeris:LTPData
 <L2P>

[:SOURCE<hw>]:BB:GNSS:SVID<ch>:GPS:NMESsage:LNAV:EPHemeris:LTPData
 <L2P>

Sets the L2 P data flag.

Parameters:

<L2P> 1 | ON | 0 | OFF
 *RST: 0

**[:SOURce<hw>]:BB:GNSS:SVID<ch>:QZSS:NMESsage:NAV:EPHemeris:FIFLag
 <FitInterval>**

**[:SOURce<hw>]:BB:GNSS:SVID<ch>:GPS:NMESsage:LNAV:EPHemeris:FIFLag
 <FitInterval>**

Sets the fit interval flag.

Parameters:

<FitInterval> 1 | ON | 0 | OFF
 *RST: 0

**[:SOURce<hw>]:BB:GNSS:SVID<ch>:QZSS:NMESsage:NAV:EPHemeris:AODO?
 [:SOURce<hw>]:BB:GNSS:SVID<ch>:GPS:NMESsage:LNAV:EPHemeris:AODO?**

Queries the age of data offset, that is fixed to 31.

Return values:

<Aodo> integer
 Range: 0 to 31
 *RST: 31

Usage: Query only

**[:SOURce<hw>]:BB:GNSS:SVID<ch>:QZSS:NMESsage:NAV:EPHemeris:
 SF1Reserved<s2us>?**

**[:SOURce<hw>]:BB:GNSS:SVID<ch>:GPS:NMESsage:LNAV:EPHemeris:
 SF1Reserved<s2us>?**

Sets the subframe 1 (reserved 1 to 4).

Return values:

<Subfr1Reserved> integer
 Range: 0 to 67108864
 *RST: 0

Usage: Query only

**[:SOURce<hw>]:BB:GNSS:SVID<ch>:GALileo:NMESsage:FNAV:EPHemeris:SISA
 <URA>**

**[:SOURce<hw>]:BB:GNSS:SVID<ch>:GALileo:NMESsage:INAV:EPHemeris:SISA
 <URA>**

Sets the signal in space accuracy index.

Parameters:

<URA> integer
 Range: 0 to 255
 *RST: 5

**[:SOURCE<hw>]:BB:GNSS:SVID<ch>:GALileo:NMESsage:INAV:E1BDVS
 <DvsE1b>**

Sets the data validity status - E1B_{DVS}.

Parameters:

<DvsE1b> integer
 Range: -1 to 1
 *RST: 0

[:SOURCE<hw>]:BB:GNSS:SVID<ch>:GALileo:NMESsage:INAV:E1BHS <HsE1b>

Sets the signal health status - E1B_{HS} parameter.

Parameters:

<HsE1b> integer
 Range: -1 to 1
 *RST: 0

**[:SOURCE<hw>]:BB:GNSS:SVID<ch>:GALileo:NMESsage:INAV:E5BDVS
 <DvsE5b>**

Sets the data validity status - E5b_{DVS} parameter.

Parameters:

<DvsE5b> integer
 Range: -1 to 1
 *RST: 0

[:SOURCE<hw>]:BB:GNSS:SVID<ch>:GALileo:NMESsage:INAV:E5BHS <HsE5b>

Sets the signal health status - E5b_{HS} parameter.

Parameters:

<HsE5b> integer
 Range: -1 to 1
 *RST: 0

**[:SOURCE<hw>]:BB:GNSS:SVID<ch>:GALileo:NMESsage:INAV:EPHemeris:SAR:
 MODE <SarMode>**

Sets the Search-and-Rescue Service (SAR) mode for SAR message generation. SAR messages are specified by the 22-bit SAR field in the I/NAV navigation message.

For more information, refer to specification Galileo OS SIS ICD.

Parameters:

<SarMode> SPARe | SRLM | LRLM

SPARe

Generates spare SAR data.

The start bit is set to one. SAR receivers interpret the following 21 spare bits as SAR non-relevant data.

SRLM/LRLM

Generates SAR data for nominal mode operation in the Galileo E1-B component. For the SAR message format, you can select between short return link message (SRLM) and long return link message (LRLM).

For the real navigation message, the Short/Long RLM Identifier, in the SAR data field is set accordingly (0 = Short RLM, 1 = Long RLM).

*RST: SPARe

Example: See [Example"Configuring Galileo Search-and-Rescue \(SAR\) data"](#) on page 479.

[:SOURCE<hw>]:BB:GNSS:SVID<ch>:GALileo:NMESsage:INAV:EPHemeris:SAR:RLM<s2us> <SarRlmData>

Sets the 20-bit Search-and-Rescue Service (SAR) return link message (RLM) data for nominal mode operation.

For more information, refer to specification Galileo OS SIS ICD.

Parameters:

<SarRlmData> integer
 Range: 0 to 1048575
 *RST: 0

Example: See [Example"Configuring Galileo Search-and-Rescue \(SAR\) data"](#) on page 479.

[:SOURCE<hw>]:BB:GNSS:SVID<ch>:GALileo:NMESsage:INAV:EPHemeris:SAR:SPARe <SpareData>

Sets the 21-bit Search-and-Rescue Service (SAR) spare data.

For more information, refer to specification Galileo OS SIS ICD.

Parameters:

<SpareData> integer
 Range: 0 to 2097151
 *RST: 0

Example: See [Example"Configuring Galileo Search-and-Rescue \(SAR\) data"](#) on page 479.

**[:SOURCE<hw>]:BB:GNSS:SVID<ch>:GALileo:NMESsage:FNAV:E5ADVS
<DvsE5a>**

Sets the data validity status - E5a_{DVS}.

Parameters:

<DvsE5a> integer
 Range: -1 to 1
 *RST: 0

[:SOURCE<hw>]:BB:GNSS:SVID<ch>:GALileo:NMESsage:FNAV:E5AHS <HsE5a>

Sets the signal health status - E5a_{HS} parameter.

Parameters:

<HsE5a> integer
 Range: -1 to 1
 *RST: 0

**[:SOURCE<hw>]:BB:GNSS:SVID<ch>:GLONass:NMESsage:NAV:EPHemeris:
SEType <SatType>**

Sets the satellite ephemeris type - M parameter.

Parameters:

<SatType> GLO | GLOM | GLOK
 GLO
 GLONASS
 GLOM
 GLONASS - M
 GLOK
 GLONASS - K
 *RST: GLOM

**[:SOURCE<hw>]:BB:GNSS:SVID<ch>:GLONass:NMESsage:NAV:EPHemeris:CFM
<FieldM>**

Sets CDMA field M parameter.

Parameters:

<FieldM> integer
 Range: 1 to 7
 *RST: 1

**[:SOURCE<hw>]:BB:GNSS:SVID<ch>:GLONass:NMESsage:NAV:EPHemeris:P
<P>**

Sets the satellite operation mode - P parameter.

Parameters:

<P> integer
 Range: 0 to 3
 *RST: 0

**[:SOURCE<hw>]:BB:GNSS:SVID<ch>:GLONASS:NMESSsage:NAV:EPHemeris:
 AOEP <AgeOfEphemeris>**

Sets the age of ephemeris page - P1 parameter.

Parameters:

<AgeOfEphemeris> A30M | A45M | A60M
 *RST: A30M

**[:SOURCE<hw>]:BB:GNSS:SVID<ch>:GLONASS:NMESSsage:NAV:EPHemeris:
 TAlignment <TbAlignment>**

Sets the t_b alignment - P2.

Parameters:

<TbAlignment> EVEN | ODD
 *RST: EVEN

**[:SOURCE<hw>]:BB:GNSS:SVID<ch>:GLONASS:NMESSsage:NAV:CCORrection:EN
 <En>**

Sets the E_n parameter.

Parameters:

<En> integer
 Range: 0 to 31
 *RST: 0

**[:SOURCE<hw>]:BB:GNSS:SV:SBAS:WAAS:NMESSsage:NAV:TIME:CONVersion:
 UTC:WNOT <WNot>**

**[:SOURCE<hw>]:BB:GNSS:SV:SBAS:MSAS:NMESSsage:NAV:TIME:CONVersion:
 UTC:WNOT <WNot>**

**[:SOURCE<hw>]:BB:GNSS:SV:SBAS:GAGAN:NMESSsage:NAV:TIME:CONVersion:
 UTC:WNOT <WNot>**

**[:SOURCE<hw>]:BB:GNSS:SV:SBAS:EGNOS:NMESSsage:NAV:TIME:CONVersion:
 UTC:WNOT <WNot>**

**[:SOURCE<hw>]:BB:GNSS:SV:NAVic:NMESSsage:NAV:TIME:CONVersion:UTC:
 WNOT <WNot>**

**[:SOURCE<hw>]:BB:GNSS:SV:QZSS:NMESSsage:CNAV:TIME:CONVersion:UTC:
 WNOT <WNot>**

**[:SOURCE<hw>]:BB:GNSS:SV:QZSS:NMESSsage:NAV:TIME:CONVersion:UTC:
 WNOT <WNot>**

```

[:SOURce<hw>]:BB:GNSS:SV:GALileo:NMESSage:FNAV:TIME:CONVersion:UTC:
WNOT <WNot>
[:SOURce<hw>]:BB:GNSS:SV:GALileo:NMESSage:INAV:TIME:CONVersion:UTC:
WNOT <WNot>
[:SOURce<hw>]:BB:GNSS:SV:BEIDou:NMESSage:CNAV:TIME:CONVersion:UTC:
WNOT <WNot>
[:SOURce<hw>]:BB:GNSS:SV:BEIDou:NMESSage:DNAV:TIME:CONVersion:UTC:
WNOT <WNot>
[:SOURce<hw>]:BB:GNSS:SV:GPS:NMESSage:CNAV:TIME:CONVersion:UTC:
WNOT <WNot>
[:SOURce<hw>]:BB:GNSS:SV:GPS:NMESSage:LNAV:TIME:CONVersion:UTC:
WNOT <WNot>

```

Sets the parameter W_{Not} .

Parameters:

<WNot>	integer
	Range: 0 to 529947
	*RST: 0

```

[:SOURce<hw>]:BB:GNSS:SV:SBAS:WAAS:NMESSage:NAV:TIME:CONVersion:
UTC:TOT:UNSCaled <Tot>
[:SOURce<hw>]:BB:GNSS:SV:SBAS:WAAS:NMESSage:NAV:TIME:CONVersion:
UTC:TOT <Tot>
[:SOURce<hw>]:BB:GNSS:SV:SBAS:MSAS:NMESSage:NAV:TIME:CONVersion:
UTC:TOT:UNSCaled <Tot>
[:SOURce<hw>]:BB:GNSS:SV:SBAS:MSAS:NMESSage:NAV:TIME:CONVersion:
UTC:TOT <Tot>
[:SOURce<hw>]:BB:GNSS:SV:SBAS:GAGAN:NMESSage:NAV:TIME:CONVersion:
UTC:TOT:UNSCaled <Tot>
[:SOURce<hw>]:BB:GNSS:SV:SBAS:GAGAN:NMESSage:NAV:TIME:CONVersion:
UTC:TOT <Tot>
[:SOURce<hw>]:BB:GNSS:SV:SBAS:EGNOS:NMESSage:NAV:TIME:CONVersion:
UTC:TOT:UNSCaled <Tot>
[:SOURce<hw>]:BB:GNSS:SV:SBAS:EGNOS:NMESSage:NAV:TIME:CONVersion:
UTC:TOT <Tot>
[:SOURce<hw>]:BB:GNSS:SV:NAVic:NMESSage:NAV:TIME:CONVersion:UTC:
TOT:UNSCaled <Tot>
[:SOURce<hw>]:BB:GNSS:SV:NAVic:NMESSage:NAV:TIME:CONVersion:UTC:
TOT <Tot>
[:SOURce<hw>]:BB:GNSS:SV:QZSS:NMESSage:CNAV:TIME:CONVersion:UTC:
TOT:UNSCaled <Tot>
[:SOURce<hw>]:BB:GNSS:SV:QZSS:NMESSage:CNAV:TIME:CONVersion:UTC:
TOT <Tot>
[:SOURce<hw>]:BB:GNSS:SV:QZSS:NMESSage:NAV:TIME:CONVersion:UTC:
TOT:UNSCaled <Tot>
[:SOURce<hw>]:BB:GNSS:SV:QZSS:NMESSage:NAV:TIME:CONVersion:UTC:
TOT <Tot>
[:SOURce<hw>]:BB:GNSS:SV:GALileo:NMESSage:FNAV:TIME:CONVersion:UTC:
TOT:UNSCaled <Tot>

```

```

[:SOURce<hw>]:BB:GNSS:SV:GALileo:NMESsage:FNAV:TIME:CONVersion:UTC:
  TOT <Tot>
[:SOURce<hw>]:BB:GNSS:SV:GALileo:NMESsage:INAV:TIME:CONVersion:UTC:
  TOT:UNSCaled <Tot>
[:SOURce<hw>]:BB:GNSS:SV:GALileo:NMESsage:INAV:TIME:CONVersion:UTC:
  TOT <Tot>
[:SOURce<hw>]:BB:GNSS:SV:BEIDou:NMESsage:CNAV:TIME:CONVersion:UTC:
  TOT:UNSCaled <Tot>
[:SOURce<hw>]:BB:GNSS:SV:BEIDou:NMESsage:CNAV:TIME:CONVersion:UTC:
  TOT <Tot>
[:SOURce<hw>]:BB:GNSS:SV:BEIDou:NMESsage:DNAV:TIME:CONVersion:UTC:
  TOT:UNSCaled <Tot>
[:SOURce<hw>]:BB:GNSS:SV:BEIDou:NMESsage:DNAV:TIME:CONVersion:UTC:
  TOT <Tot>
[:SOURce<hw>]:BB:GNSS:SV:GPS:NMESsage:CNAV:TIME:CONVersion:UTC:
  TOT:UNSCaled <Tot>
[:SOURce<hw>]:BB:GNSS:SV:GPS:NMESsage:CNAV:TIME:CONVersion:UTC:
  TOT <Tot>
[:SOURce<hw>]:BB:GNSS:SV:GPS:NMESsage:LNAV:TIME:CONVersion:UTC:
  TOT:UNSCaled <Tot>
[:SOURce<hw>]:BB:GNSS:SV:GPS:NMESsage:LNAV:TIME:CONVersion:UTC:
  TOT <Tot>

```

Sets the parameter T_{ot} .

Parameters:

<Tot> integer
 Range: 0 to 65535

```

[:SOURce<hw>]:BB:GNSS:SV:NAVic:NMESsage:NAV:TIME:CONVersion:UTC:
  ATWO:UNSCaled <A2>
[:SOURce<hw>]:BB:GNSS:SV:NAVic:NMESsage:NAV:TIME:CONVersion:UTC:
  ATWO <A2>
[:SOURce<hw>]:BB:GNSS:SV:QZSS:NMESsage:CNAV:TIME:CONVersion:UTC:
  ATWO:UNSCaled <A2>
[:SOURce<hw>]:BB:GNSS:SV:QZSS:NMESsage:CNAV:TIME:CONVersion:UTC:
  ATWO <A2>
[:SOURce<hw>]:BB:GNSS:SV:GPS:NMESsage:CNAV:TIME:CONVersion:UTC:
  ATWO:UNSCaled <A2>
[:SOURce<hw>]:BB:GNSS:SV:GPS:NMESsage:CNAV:TIME:CONVersion:UTC:
  ATWO <A2>

```

Sets the A_2 parameter.

Parameters:

<A2> integer
 Range: -64 to 63

```

[:SOURce<hw>]:BB:GNSS:SV:SBAS:WAAS:NMESsage:NAV:TIME:CONVersion:
  UTC:AONE:UNSCaled <A1>
[:SOURce<hw>]:BB:GNSS:SV:SBAS:WAAS:NMESsage:NAV:TIME:CONVersion:
  UTC:AONE <A1>
[:SOURce<hw>]:BB:GNSS:SV:SBAS:MSAS:NMESsage:NAV:TIME:CONVersion:
  UTC:AONE:UNSCaled <A1>
[:SOURce<hw>]:BB:GNSS:SV:SBAS:MSAS:NMESsage:NAV:TIME:CONVersion:
  UTC:AONE <A1>
[:SOURce<hw>]:BB:GNSS:SV:SBAS:GAGAN:NMESsage:NAV:TIME:CONVersion:
  UTC:AONE:UNSCaled <A1>
[:SOURce<hw>]:BB:GNSS:SV:SBAS:GAGAN:NMESsage:NAV:TIME:CONVersion:
  UTC:AONE <A1>
[:SOURce<hw>]:BB:GNSS:SV:SBAS:EGNOS:NMESsage:NAV:TIME:CONVersion:
  UTC:AONE:UNSCaled <A1>
[:SOURce<hw>]:BB:GNSS:SV:SBAS:EGNOS:NMESsage:NAV:TIME:CONVersion:
  UTC:AONE <A1>
[:SOURce<hw>]:BB:GNSS:SV:NAVic:NMESsage:NAV:TIME:CONVersion:UTC:
  AONE:UNSCaled <A1>
[:SOURce<hw>]:BB:GNSS:SV:NAVic:NMESsage:NAV:TIME:CONVersion:UTC:
  AONE <A1>
[:SOURce<hw>]:BB:GNSS:SV:QZSS:NMESsage:CNAV:TIME:CONVersion:UTC:
  AONE:UNSCaled <A1>
[:SOURce<hw>]:BB:GNSS:SV:QZSS:NMESsage:CNAV:TIME:CONVersion:UTC:
  AONE <A1>
[:SOURce<hw>]:BB:GNSS:SV:QZSS:NMESsage:NAV:TIME:CONVersion:UTC:
  AONE:UNSCaled <A1>
[:SOURce<hw>]:BB:GNSS:SV:QZSS:NMESsage:NAV:TIME:CONVersion:UTC:
  AONE <A1>
[:SOURce<hw>]:BB:GNSS:SV:GALileo:NMESsage:FNAV:TIME:CONVersion:UTC:
  AONE:UNSCaled <A1>
[:SOURce<hw>]:BB:GNSS:SV:GALileo:NMESsage:FNAV:TIME:CONVersion:UTC:
  AONE <A1>
[:SOURce<hw>]:BB:GNSS:SV:GALileo:NMESsage:INAV:TIME:CONVersion:UTC:
  AONE:UNSCaled <A1>
[:SOURce<hw>]:BB:GNSS:SV:GALileo:NMESsage:INAV:TIME:CONVersion:UTC:
  AONE <A1>
[:SOURce<hw>]:BB:GNSS:SV:GLONass:NMESsage:NAV:TIME:CONVersion:UTC:
  AONE:UNSCaled <A1>
[:SOURce<hw>]:BB:GNSS:SV:GLONass:NMESsage:NAV:TIME:CONVersion:UTC:
  AONE <A1>
[:SOURce<hw>]:BB:GNSS:SV:BEIDou:NMESsage:CNAV:TIME:CONVersion:UTC:
  AONE:UNSCaled <A1>
[:SOURce<hw>]:BB:GNSS:SV:BEIDou:NMESsage:CNAV:TIME:CONVersion:UTC:
  AONE <A1>
[:SOURce<hw>]:BB:GNSS:SV:BEIDou:NMESsage:DNAV:TIME:CONVersion:UTC:
  AONE:UNSCaled <A1>
[:SOURce<hw>]:BB:GNSS:SV:BEIDou:NMESsage:DNAV:TIME:CONVersion:UTC:
  AONE <A1>

```

**[:SOURCE<hw>]:BB:GNSS:SV:GPS:NMESSsage:CNAV:TIME:CONVersion:UTC:
AONE:UNSCaled <A1>**

**[:SOURCE<hw>]:BB:GNSS:SV:GPS:NMESSsage:CNAV:TIME:CONVersion:UTC:
AONE <A1>**

**[:SOURCE<hw>]:BB:GNSS:SV:GPS:NMESSsage:LNAV:TIME:CONVersion:UTC:
AONE:UNSCaled <A1>**

**[:SOURCE<hw>]:BB:GNSS:SV:GPS:NMESSsage:LNAV:TIME:CONVersion:UTC:
AONE <A1>**

Sets the parameter A_1 .

Parameters:

<A1> integer
 Range: -4096 to 4095

**[:SOURCE<hw>]:BB:GNSS:SV:SBAS:WAAS:NMESSsage:NAV:TIME:CONVersion:
UTC:AZERo:UNSCaled <A0>**

**[:SOURCE<hw>]:BB:GNSS:SV:SBAS:WAAS:NMESSsage:NAV:TIME:CONVersion:
UTC:AZERo <A0>**

**[:SOURCE<hw>]:BB:GNSS:SV:SBAS:MSAS:NMESSsage:NAV:TIME:CONVersion:
UTC:AZERo:UNSCaled <A0>**

**[:SOURCE<hw>]:BB:GNSS:SV:SBAS:MSAS:NMESSsage:NAV:TIME:CONVersion:
UTC:AZERo <A0>**

**[:SOURCE<hw>]:BB:GNSS:SV:SBAS:GAGAN:NMESSsage:NAV:TIME:CONVersion:
UTC:AZERo:UNSCaled <A0>**

**[:SOURCE<hw>]:BB:GNSS:SV:SBAS:GAGAN:NMESSsage:NAV:TIME:CONVersion:
UTC:AZERo <A0>**

**[:SOURCE<hw>]:BB:GNSS:SV:SBAS:EGNOS:NMESSsage:NAV:TIME:CONVersion:
UTC:AZERo:UNSCaled <A0>**

**[:SOURCE<hw>]:BB:GNSS:SV:SBAS:EGNOS:NMESSsage:NAV:TIME:CONVersion:
UTC:AZERo <A0>**

**[:SOURCE<hw>]:BB:GNSS:SV:NAVic:NMESSsage:NAV:TIME:CONVersion:UTC:
AZERo:UNSCaled <A0>**

**[:SOURCE<hw>]:BB:GNSS:SV:NAVic:NMESSsage:NAV:TIME:CONVersion:UTC:
AZERo <A0>**

**[:SOURCE<hw>]:BB:GNSS:SV:QZSS:NMESSsage:CNAV:TIME:CONVersion:UTC:
AZERo:UNSCaled <A0>**

**[:SOURCE<hw>]:BB:GNSS:SV:QZSS:NMESSsage:CNAV:TIME:CONVersion:UTC:
AZERo <A0>**

**[:SOURCE<hw>]:BB:GNSS:SV:QZSS:NMESSsage:NAV:TIME:CONVersion:UTC:
AZERo:UNSCaled <A0>**

**[:SOURCE<hw>]:BB:GNSS:SV:QZSS:NMESSsage:NAV:TIME:CONVersion:UTC:
AZERo <A0>**

**[:SOURCE<hw>]:BB:GNSS:SV:GALileo:NMESSsage:FNAV:TIME:CONVersion:UTC:
AZERo:UNSCaled <A0>**

**[:SOURCE<hw>]:BB:GNSS:SV:GALileo:NMESSsage:FNAV:TIME:CONVersion:UTC:
AZERo <A0>**

**[:SOURCE<hw>]:BB:GNSS:SV:GALileo:NMESSsage:INAV:TIME:CONVersion:UTC:
AZERo:UNSCaled <A0>**

```

[:SOURce<hw>]:BB:GNSS:SV:GALileo:NMESsage:INAV:TIME:CONVersion:UTC:
  AZERo <A0>
[:SOURce<hw>]:BB:GNSS:SV:GLONass:NMESsage:NAV:TIME:CONVersion:UTC:
  AZERo:UNSCaled <A0>
[:SOURce<hw>]:BB:GNSS:SV:GLONass:NMESsage:NAV:TIME:CONVersion:UTC:
  AZERo <A0>
[:SOURce<hw>]:BB:GNSS:SV:BEIDou:NMESsage:CNAV:TIME:CONVersion:UTC:
  AZERo:UNSCaled <A0>
[:SOURce<hw>]:BB:GNSS:SV:BEIDou:NMESsage:CNAV:TIME:CONVersion:UTC:
  AZERo <A0>
[:SOURce<hw>]:BB:GNSS:SV:BEIDou:NMESsage:DNAV:TIME:CONVersion:UTC:
  AZERo:UNSCaled <A0>
[:SOURce<hw>]:BB:GNSS:SV:BEIDou:NMESsage:DNAV:TIME:CONVersion:UTC:
  AZERo <A0>
[:SOURce<hw>]:BB:GNSS:SV:GPS:NMESsage:CNAV:TIME:CONVersion:UTC:
  AZERo:UNSCaled <A0>
[:SOURce<hw>]:BB:GNSS:SV:GPS:NMESsage:CNAV:TIME:CONVersion:UTC:
  AZERo <A0>
[:SOURce<hw>]:BB:GNSS:SV:GPS:NMESsage:LNAV:TIME:CONVersion:UTC:
  AZERo:UNSCaled <A0>
[:SOURce<hw>]:BB:GNSS:SV:GPS:NMESsage:LNAV:TIME:CONVersion:UTC:
  AZERo <A0>

```

Sets the parameter A_0 .

Parameters:

<A0> integer
 Range: -32768 to 32767

```

[:SOURce<hw>]:BB:GNSS:SV:NAVic:NMESsage:NAV:TIME:CONVersion:GPS:
  WNOT <WNot>
[:SOURce<hw>]:BB:GNSS:SV:GALileo:NMESsage:FNAV:TIME:CONVersion:GPS:
  WNOT <WNot>
[:SOURce<hw>]:BB:GNSS:SV:GALileo:NMESsage:INAV:TIME:CONVersion:GPS:
  WNOT <WNot>

```

Sets the W_{Not} parameter.

Parameters:

<WNot> integer
 Range: 0 to 529947
 *RST: 0

```

[:SOURce<hw>]:BB:GNSS:SV:NAVic:NMESsage:NAV:TIME:CONVersion:GPS:
  TOT:UNSCaled <Tot>
[:SOURce<hw>]:BB:GNSS:SV:NAVic:NMESsage:NAV:TIME:CONVersion:GPS:
  TOT <Tot>
[:SOURce<hw>]:BB:GNSS:SV:BEIDou:NMESsage:CNAV:TIME:CONVersion:GPS:
  TOT:UNSCaled <Tot>

```

```

[:SOURce<hw>]:BB:GNSS:SV:BEIDou:NMESSage:CNAV:TIME:CONVersion:GPS:
  TOT <Tot>
[:SOURce<hw>]:BB:GNSS:SV:BEIDou:NMESSage:DNAV:TIME:CONVersion:GPS:
  TOT:UNSCaled <Tot>
[:SOURce<hw>]:BB:GNSS:SV:BEIDou:NMESSage:DNAV:TIME:CONVersion:GPS:
  TOT <Tot>
[:SOURce<hw>]:BB:GNSS:SV:GALileo:NMESSage:FNAV:TIME:CONVersion:GPS:
  TOT:UNSCaled <Tot>
[:SOURce<hw>]:BB:GNSS:SV:GALileo:NMESSage:FNAV:TIME:CONVersion:GPS:
  TOT <Tot>
[:SOURce<hw>]:BB:GNSS:SV:GALileo:NMESSage:INAV:TIME:CONVersion:GPS:
  TOT:UNSCaled <Tot>
[:SOURce<hw>]:BB:GNSS:SV:GALileo:NMESSage:INAV:TIME:CONVersion:GPS:
  TOT <Tot>

```

Sets the T_{ot} parameter.

Parameters:

<Tot> integer
 Range: 0 to 65535

```

[:SOURce<hw>]:BB:GNSS:SV:NAVic:NMESSage:NAV:TIME:CONVersion:GPS:
  AZERo:UNSCaled <A0>
[:SOURce<hw>]:BB:GNSS:SV:NAVic:NMESSage:NAV:TIME:CONVersion:GPS:
  AZERo <A0>
[:SOURce<hw>]:BB:GNSS:SV:GLONass:NMESSage:NAV:TIME:CONVersion:GPS:
  AZERo:UNSCaled <A0>
[:SOURce<hw>]:BB:GNSS:SV:GLONass:NMESSage:NAV:TIME:CONVersion:GPS:
  AZERo <A0>
[:SOURce<hw>]:BB:GNSS:SV:GALileo:NMESSage:FNAV:TIME:CONVersion:GPS:
  AZERo:UNSCaled <A0>
[:SOURce<hw>]:BB:GNSS:SV:GALileo:NMESSage:FNAV:TIME:CONVersion:GPS:
  AZERo <A0>
[:SOURce<hw>]:BB:GNSS:SV:GALileo:NMESSage:INAV:TIME:CONVersion:GPS:
  AZERo:UNSCaled <A0>
[:SOURce<hw>]:BB:GNSS:SV:GALileo:NMESSage:INAV:TIME:CONVersion:GPS:
  AZERo <A0>
[:SOURce<hw>]:BB:GNSS:SV:BEIDou:NMESSage:CNAV:TIME:CONVersion:GPS:
  AZERo:UNSCaled <A0>
[:SOURce<hw>]:BB:GNSS:SV:BEIDou:NMESSage:CNAV:TIME:CONVersion:GPS:
  AZERo <A0>
[:SOURce<hw>]:BB:GNSS:SV:BEIDou:NMESSage:DNAV:TIME:CONVersion:GPS:
  AZERo:UNSCaled <A0>
[:SOURce<hw>]:BB:GNSS:SV:BEIDou:NMESSage:DNAV:TIME:CONVersion:GPS:
  AZERo <A0>

```

Sets the A_0 parameter.

Parameters:

<A0> integer
 Range: -32768 to 32767

```

[:SOURce<hw>]:BB:GNSS:SV:NAVic:NMESsage:NAV:TIME:CONVersion:GPS:
  AONE:UNSCaled <A1>
[:SOURce<hw>]:BB:GNSS:SV:NAVic:NMESsage:NAV:TIME:CONVersion:GPS:
  AONE <A1>
[:SOURce<hw>]:BB:GNSS:SV:GALileo:NMESsage:FNAV:TIME:CONVersion:GPS:
  AONE:UNSCaled <A1>
[:SOURce<hw>]:BB:GNSS:SV:GALileo:NMESsage:FNAV:TIME:CONVersion:GPS:
  AONE <A1>
[:SOURce<hw>]:BB:GNSS:SV:GALileo:NMESsage:INAV:TIME:CONVersion:GPS:
  AONE:UNSCaled <A1>
[:SOURce<hw>]:BB:GNSS:SV:GALileo:NMESsage:INAV:TIME:CONVersion:GPS:
  AONE <A1>
[:SOURce<hw>]:BB:GNSS:SV:BEIDou:NMESsage:CNAV:TIME:CONVersion:GPS:
  AONE:UNSCaled <A1>
[:SOURce<hw>]:BB:GNSS:SV:BEIDou:NMESsage:CNAV:TIME:CONVersion:GPS:
  AONE <A1>
[:SOURce<hw>]:BB:GNSS:SV:BEIDou:NMESsage:DNAV:TIME:CONVersion:GPS:
  AONE:UNSCaled <A1>
[:SOURce<hw>]:BB:GNSS:SV:BEIDou:NMESsage:DNAV:TIME:CONVersion:GPS:
  AONE <A1>

```

Sets the A_1 parameter.

Parameters:

<A1> integer
 Range: -4096 to 4095

```

[:SOURce<hw>]:BB:GNSS:SV:NAVic:NMESsage:NAV:TIME:CONVersion:GPS:
  ATWO:UNSCaled <A2>
[:SOURce<hw>]:BB:GNSS:SV:NAVic:NMESsage:NAV:TIME:CONVersion:GPS:
  ATWO <A2>

```

Sets the A_2 parameter.

Parameters:

<A2> integer
 Range: -64 to 63

```

[:SOURce<hw>]:BB:GNSS:SV:GPS:NMESsage:CNAV:TIME:CONVersion:GALileo:
  WNOT <WNot>

```

Sets the W_{not} parameter.

Parameters:

<WNot> integer
 Range: 0 to 529947
 *RST: 0

```

[:SOURce<hw>]:BB:GNSS:SV:BEIDou:NMESsage:CNAV:TIME:CONVersion:
  GALileo:TOT:UNSCaled <Tot>
[:SOURce<hw>]:BB:GNSS:SV:BEIDou:NMESsage:CNAV:TIME:CONVersion:
  GALileo:TOT <Tot>
[:SOURce<hw>]:BB:GNSS:SV:BEIDou:NMESsage:DNAV:TIME:CONVersion:
  GALileo:TOT:UNSCaled <Tot>
[:SOURce<hw>]:BB:GNSS:SV:BEIDou:NMESsage:DNAV:TIME:CONVersion:
  GALileo:TOT <Tot>
[:SOURce<hw>]:BB:GNSS:SV:GPS:NMESsage:CNAV:TIME:CONVersion:GALileo:
  TOT:UNSCaled <Tot>
[:SOURce<hw>]:BB:GNSS:SV:GPS:NMESsage:CNAV:TIME:CONVersion:GALileo:
  TOT <Tot>

```

Sets the T_{ot} parameter.

Parameters:

<Tot> integer
 Range: 0 to 65535

```

[:SOURce<hw>]:BB:GNSS:SV:BEIDou:NMESsage:CNAV:TIME:CONVersion:
  GALileo:AZERo:UNSCaled <A0>
[:SOURce<hw>]:BB:GNSS:SV:BEIDou:NMESsage:CNAV:TIME:CONVersion:
  GALileo:AZERo <A0>
[:SOURce<hw>]:BB:GNSS:SV:BEIDou:NMESsage:DNAV:TIME:CONVersion:
  GALileo:AZERo:UNSCaled <A0>
[:SOURce<hw>]:BB:GNSS:SV:BEIDou:NMESsage:DNAV:TIME:CONVersion:
  GALileo:AZERo <A0>
[:SOURce<hw>]:BB:GNSS:SV:GPS:NMESsage:CNAV:TIME:CONVersion:GALileo:
  AZERo:UNSCaled <A0>
[:SOURce<hw>]:BB:GNSS:SV:GPS:NMESsage:CNAV:TIME:CONVersion:GALileo:
  AZERo <A0>

```

Sets the A_0 parameter.

Parameters:

<A0> integer
 Range: -32768 to 32767

```

[:SOURce<hw>]:BB:GNSS:SV:BEIDou:NMESsage:CNAV:TIME:CONVersion:
  GALileo:AONE:UNSCaled <A1>
[:SOURce<hw>]:BB:GNSS:SV:BEIDou:NMESsage:CNAV:TIME:CONVersion:
  GALileo:AONE <A1>
[:SOURce<hw>]:BB:GNSS:SV:BEIDou:NMESsage:DNAV:TIME:CONVersion:
  GALileo:AONE:UNSCaled <A1>
[:SOURce<hw>]:BB:GNSS:SV:BEIDou:NMESsage:DNAV:TIME:CONVersion:
  GALileo:AONE <A1>

```

**[:SOURce<hw>]:BB:GNSS:SV:GPS:NMESSage:CNAV:TIME:CONVersion:GALileo:
AONE:UNSCaled <A1>**

**[:SOURce<hw>]:BB:GNSS:SV:GPS:NMESSage:CNAV:TIME:CONVersion:GALileo:
AONE <A1>**

Sets the A_1 parameter.

Parameters:

<A1> integer
Range: -4096 to 4095

**[:SOURce<hw>]:BB:GNSS:SV:GPS:NMESSage:CNAV:TIME:CONVersion:GALileo:
ATWO:UNSCaled <A2>**

**[:SOURce<hw>]:BB:GNSS:SV:GPS:NMESSage:CNAV:TIME:CONVersion:GALileo:
ATWO <A2>**

Sets the A_2 parameter.

Parameters:

<A2> integer
Range: -64 to 63

**[:SOURce<hw>]:BB:GNSS:SV:GPS:NMESSage:CNAV:TIME:CONVersion:
GLONass:WNOT <WNot>**

Sets the W_{Not} parameter.

Parameters:

<WNot> integer
Range: 0 to 529947
*RST: 0

**[:SOURce<hw>]:BB:GNSS:SV:BEIDou:NMESSage:CNAV:TIME:CONVersion:
GLONass:TOT:UNSCaled <Tot>**

**[:SOURce<hw>]:BB:GNSS:SV:BEIDou:NMESSage:CNAV:TIME:CONVersion:
GLONass:TOT <Tot>**

**[:SOURce<hw>]:BB:GNSS:SV:BEIDou:NMESSage:DNAV:TIME:CONVersion:
GLONass:TOT:UNSCaled <Tot>**

**[:SOURce<hw>]:BB:GNSS:SV:BEIDou:NMESSage:DNAV:TIME:CONVersion:
GLONass:TOT <Tot>**

**[:SOURce<hw>]:BB:GNSS:SV:GPS:NMESSage:CNAV:TIME:CONVersion:
GLONass:TOT:UNSCaled <Tot>**

**[:SOURce<hw>]:BB:GNSS:SV:GPS:NMESSage:CNAV:TIME:CONVersion:
GLONass:TOT <Tot>**

Sets the T_{ot} parameter.

Parameters:

<Tot> integer
Range: 0 to 65535

```
[:SOURce<hw>]:BB:GNSS:SV:BEIDou:NMESsage:CNAV:TIME:CONVersion:
      GLONass:AZERo:UNSCaled <A0>
```

```
[:SOURce<hw>]:BB:GNSS:SV:BEIDou:NMESsage:CNAV:TIME:CONVersion:
      GLONass:AZERo <A0>
```

```
[:SOURce<hw>]:BB:GNSS:SV:BEIDou:NMESsage:DNAV:TIME:CONVersion:
      GLONass:AZERo:UNSCaled <A0>
```

```
[:SOURce<hw>]:BB:GNSS:SV:BEIDou:NMESsage:DNAV:TIME:CONVersion:
      GLONass:AZERo <A0>
```

```
[:SOURce<hw>]:BB:GNSS:SV:GPS:NMESsage:CNAV:TIME:CONVersion:
      GLONass:AZERo:UNSCaled <A0>
```

```
[:SOURce<hw>]:BB:GNSS:SV:GPS:NMESsage:CNAV:TIME:CONVersion:
      GLONass:AZERo <A0>
```

Parameters:

```
<A0>                integer
                    Range:    -32768 to 32767
```

```
[:SOURce<hw>]:BB:GNSS:SV:BEIDou:NMESsage:CNAV:TIME:CONVersion:
      GLONass:AONE:UNSCaled <A1>
```

```
[:SOURce<hw>]:BB:GNSS:SV:BEIDou:NMESsage:CNAV:TIME:CONVersion:
      GLONass:AONE <A1>
```

```
[:SOURce<hw>]:BB:GNSS:SV:BEIDou:NMESsage:DNAV:TIME:CONVersion:
      GLONass:AONE:UNSCaled <A1>
```

```
[:SOURce<hw>]:BB:GNSS:SV:BEIDou:NMESsage:DNAV:TIME:CONVersion:
      GLONass:AONE <A1>
```

```
[:SOURce<hw>]:BB:GNSS:SV:GPS:NMESsage:CNAV:TIME:CONVersion:
      GLONass:AONE:UNSCaled <A1>
```

```
[:SOURce<hw>]:BB:GNSS:SV:GPS:NMESsage:CNAV:TIME:CONVersion:
      GLONass:AONE <A1>
```

Sets the A_1 parameter.

Parameters:

```
<A1>                integer
                    Range:    -4096 to 4095
```

```
[:SOURce<hw>]:BB:GNSS:SV:GPS:NMESsage:CNAV:TIME:CONVersion:
      GLONass:ATWO:UNSCaled <A2>
```

```
[:SOURce<hw>]:BB:GNSS:SV:GPS:NMESsage:CNAV:TIME:CONVersion:
      GLONass:ATWO <A2>
```

Sets the A_2 parameter.

Parameters:

```
<A2>                integer
                    Range:    -64 to 63
```

```

[:SOURce<hw>]:BB:GNSS:ATMospheric:NAVic:NMESsage:NAV:IONospheric:
  ALPHa<ch0>:UNSCaled <AlphaUnscaled>
[:SOURce<hw>]:BB:GNSS:ATMospheric:NAVic:NMESsage:NAV:IONospheric:
  ALPHa<ch0> <Alpha>
[:SOURce<hw>]:BB:GNSS:ATMospheric:QZSS:NMESsage:CNAV:IONospheric:
  ALPHa<ch0>:UNSCaled <AlphaUnscaled>
[:SOURce<hw>]:BB:GNSS:ATMospheric:QZSS:NMESsage:CNAV:IONospheric:
  ALPHa<ch0> <Alpha>
[:SOURce<hw>]:BB:GNSS:ATMospheric:QZSS:NMESsage:NAV:IONospheric:
  ALPHa<ch0>:UNSCaled <AlphaUnscaled>
[:SOURce<hw>]:BB:GNSS:ATMospheric:QZSS:NMESsage:NAV:IONospheric:
  ALPHa<ch0> <Alpha>
[:SOURce<hw>]:BB:GNSS:ATMospheric:BEIDou:NMESsage:CNAV:IONospheric:
  ALPHa<ch0>:UNSCaled <AlphaUnscaled>
[:SOURce<hw>]:BB:GNSS:ATMospheric:BEIDou:NMESsage:CNAV:IONospheric:
  ALPHa<ch0> <Alpha>
[:SOURce<hw>]:BB:GNSS:ATMospheric:BEIDou:NMESsage:DNAV:IONospheric:
  ALPHa<ch0>:UNSCaled <AlphaUnscaled>
[:SOURce<hw>]:BB:GNSS:ATMospheric:BEIDou:NMESsage:DNAV:IONospheric:
  ALPHa<ch0> <Alpha>
[:SOURce<hw>]:BB:GNSS:ATMospheric:GPS:NMESsage:CNAV:IONospheric:
  ALPHa<ch0>:UNSCaled <AlphaUnscaled>
[:SOURce<hw>]:BB:GNSS:ATMospheric:GPS:NMESsage:CNAV:IONospheric:
  ALPHa<ch0> <Alpha>
[:SOURce<hw>]:BB:GNSS:ATMospheric:GPS:NMESsage:LNAV:IONospheric:
  ALPHa<ch0>:UNSCaled <AlphaUnscaled>
[:SOURce<hw>]:BB:GNSS:ATMospheric:GPS:NMESsage:LNAV:IONospheric:
  ALPHa<ch0> <Alpha>

```

Sets the parameters alpha_0 to alpha_3 of the satellite's navigation message.

Suffix:

<ch0> 0 to 3

Parameters:

<Alpha> integer
 Range: -128 to 127
 *RST: 0

```

[:SOURce<hw>]:BB:GNSS:ATMospheric:GALileo:NMESsage:FNAV:IONospheric:
  AI<ch0>:UNSCaled <AiUnscaled>
[:SOURce<hw>]:BB:GNSS:ATMospheric:GALileo:NMESsage:FNAV:IONospheric:
  AI<ch0> <A_i>
[:SOURce<hw>]:BB:GNSS:ATMospheric:GALileo:NMESsage:INAV:IONospheric:
  AI<ch0>:UNSCaled <AiUnscaled>
[:SOURce<hw>]:BB:GNSS:ATMospheric:GALileo:NMESsage:INAV:IONospheric:
  AI<ch0> <A_i>

```

Sets the parameters effective ionization level 1st to 3rd order of the satellite's navigation message.

Parameters:

<A_i>	integer	
	Range:	a_i0 (0 to 2047), a_i1 (-1024 to 1023), a_i2 (-8192 to 8191)
	*RST:	0

```

[:SOURce<hw>]:BB:GNSS:ATMospheric:NAVic:NMESsage:NAV:IONospheric:
  BETA<ch0>:UNSCaled <BetaUnscaled>
[:SOURce<hw>]:BB:GNSS:ATMospheric:NAVic:NMESsage:NAV:IONospheric:
  BETA<ch0> <Beta>
[:SOURce<hw>]:BB:GNSS:ATMospheric:QZSS:NMESsage:CNAV:IONospheric:
  BETA<ch0>:UNSCaled <BetaUnscaled>
[:SOURce<hw>]:BB:GNSS:ATMospheric:QZSS:NMESsage:CNAV:IONospheric:
  BETA<ch0> <Beta>
[:SOURce<hw>]:BB:GNSS:ATMospheric:QZSS:NMESsage:NAV:IONospheric:
  BETA<ch0>:UNSCaled <BetaUnscaled>
[:SOURce<hw>]:BB:GNSS:ATMospheric:QZSS:NMESsage:NAV:IONospheric:
  BETA<ch0> <Beta>
[:SOURce<hw>]:BB:GNSS:ATMospheric:BEIDou:NMESsage:CNAV:IONospheric:
  BETA<ch0>:UNSCaled <BetaUnscaled>
[:SOURce<hw>]:BB:GNSS:ATMospheric:BEIDou:NMESsage:CNAV:IONospheric:
  BETA<ch0> <Beta>
[:SOURce<hw>]:BB:GNSS:ATMospheric:BEIDou:NMESsage:DNAV:IONospheric:
  BETA<ch0>:UNSCaled <BetaUnscaled>
[:SOURce<hw>]:BB:GNSS:ATMospheric:BEIDou:NMESsage:DNAV:IONospheric:
  BETA<ch0> <Beta>
[:SOURce<hw>]:BB:GNSS:ATMospheric:GPS:NMESsage:CNAV:IONospheric:
  BETA<ch0>:UNSCaled <BetaUnscaled>
[:SOURce<hw>]:BB:GNSS:ATMospheric:GPS:NMESsage:CNAV:IONospheric:
  BETA<ch0> <Beta>
[:SOURce<hw>]:BB:GNSS:ATMospheric:GPS:NMESsage:LNAV:IONospheric:
  BETA<ch0>:UNSCaled <BetaUnscaled>
[:SOURce<hw>]:BB:GNSS:ATMospheric:GPS:NMESsage:LNAV:IONospheric:
  BETA<ch0> <Beta>

```

Sets the parameters beta_0 to beta_3 of the satellite's navigation message.

Suffix:

<ch0>	0 to 3
-------	--------

Parameters:

<Beta>	integer	
	Range:	-128 to 127
	*RST:	0

```
[:SOURce<hw>]:BB:GNSS:ATMospheric:GALileo:NMESsage:FNAV:IONospheric:
SF<ch> <SF>
```

```
[:SOURce<hw>]:BB:GNSS:ATMospheric:GALileo:NMESsage:INAV:IONospheric:
SF<ch> <SF>
```

Sets the parameters ionospheric disturbance flag for region 1 to 5 of the satellite's navigation message.

Suffix:

<ch> 1 to 5

Parameters:

<SF> integer
 Range: 0 to 1
 *RST: 0

22.14 Galileo OSNMA commands

Option: R&S SMW-K66

Example: To configure Galileo OSNMA realtime parameters

```
// *****
// Configure general OSNMA settings.
// *****
:SOURce1:BB:GNSS:GALileo:OSNMa:MACLt 28
// Sets 28 that is the 11100 bit for the MAC look-up table.
:SOURce1:BB:GNSS:GALileo:OSNMa:TS 5
// The tag length l_t is 20 bits.
:SOURce1:BB:GNSS:GALileo:OSNMa:KS 0
// The key length l_k is 96 bits.
:SOURce1:BB:GNSS:GALileo:OSNMa:HF 0
// The hash function is SHA-256.
:SOURce1:BB:GNSS:GALileo:OSNMa:NPKT 1
// The DSM-PKR is an ECDSA P-256 message.

:SOURce1:BB:GNSS:GALileo:OSNMa:MF 1
// Sets the MAC Function bit to 1 that corresponds to the hash function CMAC-AES.
:SOURce1:BB:GNSS:GALileo:OSNMa:AESKey:LENGth AES128
// Sets the length of 128 bits of the cipher-based message authentication code
// (CMAC) key.
:SOURce1:BB:GNSS:GALileo:OSNMa:PID 4
// The ID of the public key is 4.
:SOURce1:BB:GNSS:GALileo:OSNMa:ADKD?
// Response: "0"
// The authentication data and key delay (ADKD) for ADKD=4 is disabled.
:SOURce1:BB:GNSS:GALileo:OSNMa:SPReemption?
// Response: "0"
// Status preemption is disabled.
```

```
// Optionally, set an additional delay of one subframe of the navigation data.
:SOURcel:BB:GNSS:GALileo:OSNMa:ADDelay 1

// *****
// Configure TESLA chain settings.
// *****
SOURcel:BB:GNSS:GALileo:OSNMa:TMODe TREN
// Sets for TESLA Chain Renewal transition mode.
:SOURcel:BB:GNSS:GALileo:OSNMa:NTDay 4
// Sets four root key transitions per day.
:SOURcel:BB:GNSS:GALileo:OSNMa:RKEY:TOMid 10800
// Sets an offset of 10800 seconds or three hours of the TESLA chain transitions
// per day.
:SOURcel:BB:GNSS:GALileo:OSNMa:PKEY:TDURation:SONE 3600
:SOURcel:BB:GNSS:GALileo:OSNMa:PKEY:TDURation:STWO 3600
// The durations of step one and step two for TESLA chain transitions are 3600
// seconds or one hour.

// *****
// Configure Public key renewal settings.
// *****
:SOURcel:BB:GNSS:GALileo:OSNMa:TMODe PREN
// Sets for Public Key Renewal transition mode.
:SOURcel:BB:GNSS:GALileo:OSNMa:PKEY:TOMid 10800
// Sets an offset of 10800 seconds or three hours of the Public key transitions
// per day.
:SOURcel:BB:GNSS:GALileo:OSNMa:PKEY:NTDay 4
// Sets four Public key transitions per day.
:SOURcel:BB:GNSS:GALileo:OSNMa:PKEY:TDURation:SONE 3600
:SOURcel:BB:GNSS:GALileo:OSNMa:PKEY:TDURation:STWO 3600
// The durations of step one and step two for Public key transitions are 3600
// seconds or one hour.
```

Commands:

[:SOURce<hw>]:BB:GNSS:GALileo:OSNMa:ADDelay.....	568
[:SOURce<hw>]:BB:GNSS:GALileo:OSNMa:ADKD.....	568
[:SOURce<hw>]:BB:GNSS:GALileo:OSNMa:AESKey:LENGth.....	568
[:SOURce<hw>]:BB:GNSS:GALileo:OSNMa:CKEY:TDURation:SONE.....	569
[:SOURce<hw>]:BB:GNSS:GALileo:OSNMa:CKEY:TDURation:STWO.....	569
[:SOURce<hw>]:BB:GNSS:GALileo:OSNMa:HF.....	569
[:SOURce<hw>]:BB:GNSS:GALileo:OSNMa:KS.....	569
[:SOURce<hw>]:BB:GNSS:GALileo:OSNMa:MACLt.....	570
[:SOURce<hw>]:BB:GNSS:GALileo:OSNMa:MF.....	570
[:SOURce<hw>]:BB:GNSS:GALileo:OSNMa:NPKT.....	570
[:SOURce<hw>]:BB:GNSS:GALileo:OSNMa:PID.....	571
[:SOURce<hw>]:BB:GNSS:GALileo:OSNMa:PKEY:NTDay.....	571
[:SOURce<hw>]:BB:GNSS:GALileo:OSNMa:PKEY:TDURation:SONE.....	571
[:SOURce<hw>]:BB:GNSS:GALileo:OSNMa:PKEY:TDURation:STWO.....	571
[:SOURce<hw>]:BB:GNSS:GALileo:OSNMa:PKEY:TOMidnight.....	572
[:SOURce<hw>]:BB:GNSS:GALileo:OSNMa:RKEY:NTDay.....	572

[:SOURce<hw>]:BB:GNSS:GALileo:OSNMa:RKEY:TOMidnight.....	572
[:SOURce<hw>]:BB:GNSS:GALileo:OSNMa:SPReemption.....	573
[:SOURce<hw>]:BB:GNSS:GALileo:OSNMa:TMODe.....	573
[:SOURce<hw>]:BB:GNSS:GALileo:OSNMa:TS.....	573

[:SOURce<hw>]:BB:GNSS:GALileo:OSNMa:ADDelay <Delay>

Sets an additional delay in subframes of the navigation data for the tag verification. The delay can depend on receiver implementation.

You can set a delay of one subframe. A zero subframe delay corresponds to no delay.

Parameters:

<Delay> integer
 Range: 0 to 1
 *RST: 1

Example: See [Example "To configure Galileo OSNMA realtime parameters"](#) on page 566.

Manual operation: See ["Additional Data Delay for Tag Verification"](#) on page 176

[:SOURce<hw>]:BB:GNSS:GALileo:OSNMa:ADKD <State>

Enable the authentication data and key delay (ADKD) for ADKD=4 for Galileo I/NAV timing parameters.

Parameters:

<State> 1 | ON | 0 | OFF
 *RST: 0

Example: See [Example "To configure Galileo OSNMA realtime parameters"](#) on page 566.

Manual operation: See ["Test Phase ADKD4"](#) on page 176

[:SOURce<hw>]:BB:GNSS:GALileo:OSNMa:AESKey:LENGth <KeyLength>

Sets the length of the cipher-based message authentication code (CMAC) key.

Setting requires a MAC Function (MF) field value of 1:

```
:SOURce1:BB:GNSS:GALileo:OSNMa:MF 1
```

See also [\[:SOURce<hw>\]:BB:GNSS:GALileo:OSNMa:MF](#) on page 570.

Parameters:

<KeyLength> AES128 | AES256
AES128
 The length of the CMAC key is 128 bits.
AES256
 The length of the CMAC key is 256 bits.
 *RST: AES128

Example: See [Example "To configure Galileo OSNMA realtime parameters"](#) on page 566.

Manual operation: See ["CMAC AES Key Length"](#) on page 175

[:SOURCE<hw>] : BB : GNSS : GALileo : OSNMA : CKEY : TDURATION : SONE <Duration>

Sets the duration of step 1 for TESLA chain transitions.

Parameters:

<Duration> integer
 Range: 1 to 86400
 *RST: 3600

Example: See [Example "To configure Galileo OSNMA realtime parameters"](#) on page 566.

[:SOURCE<hw>] : BB : GNSS : GALileo : OSNMA : CKEY : TDURATION : STWO <Duration>

Sets the duration of step 2 for TESLA chain transitions.

Parameters:

<Duration> integer
 Range: 1 to 86400
 *RST: 3600

Example: See [Example "To configure Galileo OSNMA realtime parameters"](#) on page 566.

[:SOURCE<hw>] : BB : GNSS : GALileo : OSNMA : HF <Value>

Sets the bits in the 2-bit Hash Function (HF) field.

Parameters:

<Value> 0 | 2
 For a description on HF values, see [Table 10-6](#).
 *RST: 0

Example: See [Example "To configure Galileo OSNMA realtime parameters"](#) on page 566.

Manual operation: See ["HF"](#) on page 174

[:SOURCE<hw>] : BB : GNSS : GALileo : OSNMA : KS <Value>

Sets the bits in the 4-bit Key Size (KS) field.

Parameters:

<Value> 0 | 1 | 2 | 3 | 4 | 5 | 6 | 7 | 8
 For a description on KS values, see [Table 10-5](#).
 *RST: 0

Example: See [Example "To configure Galileo OSNMA realtime parameters"](#) on page 566.

Manual operation: See ["KS"](#) on page 174

[:SOURCE<hw>] :BB:GNSS:GALileo:OSNMa:MACLT <Value>

Sets the bits in the 8-bit MAC Look-up Table (MACLT) field.

Parameters:

<Value> 27 | 28 | 31 | 33 | 34 | 35 | 36 | 37 | 38 | 39 | 40 | 41
 *RST: 28

Example: See [Example "To configure Galileo OSNMA realtime parameters"](#) on page 566.

Manual operation: See ["MACLT"](#) on page 173

[:SOURCE<hw>] :BB:GNSS:GALileo:OSNMa:MF <MF>

Sets the bits in the 2-bit MAC Function (MF) field.

Parameters:

<MF> integer
 For a description on MF values, see [Table 10-8](#).
 Range: 0 to 1
 *RST: 0

Example: See [Example "To configure Galileo OSNMA realtime parameters"](#) on page 566.

Manual operation: See ["MF"](#) on page 175

[:SOURCE<hw>] :BB:GNSS:GALileo:OSNMa:NPKT <Value>

Sets the bits in the 4-bit New Public Key Type (NPKT) field.

This field represents the signature algorithm associated with the public key provided in the digital signature message for a public key renewal (DSM-PKR).

Parameters:

<Value> 1 | 3
 For a description on NPKT values, see [Table 10-7](#).
 *RST: 1

Example: See [Example "To configure Galileo OSNMA realtime parameters"](#) on page 566.

Manual operation: See ["NPKT"](#) on page 174

[:SOURce<hw>]:BB:GNSS:GALileo:OSNMa:PID <PidInput2>

Sets the ID of the Public Key (PK) used to verify the signature of the digital signature message for a root key (DSM-KROOT).

If the transition mode defines the change of the public key, the PKID depends on the simulation time. This PKID means the public key which is currently in use and the PKID is increased by each public key transition.

Parameters:

<PidInput2> integer
 Range: 0 to 15
 *RST: 0

Example: See [Example "To configure Galileo OSNMA realtime parameters"](#) on page 566.

Manual operation: See ["PID"](#) on page 175

[:SOURce<hw>]:BB:GNSS:GALileo:OSNMa:PKEY:NTDay <TransPerDay>

Sets the number of Public key transitions per day.

Parameters:

<TransPerDay> integer
 Range: 1 to 24
 *RST: 4

Example: See [Example "To configure Galileo OSNMA realtime parameters"](#) on page 566.

[:SOURce<hw>]:BB:GNSS:GALileo:OSNMa:PKEY:TDURATION:SONE <Duration>

Sets the duration of step 1 for Public key transitions.

Parameters:

<Duration> integer
 Range: 1 to 86400
 *RST: 3600

Example: See [Example "To configure Galileo OSNMA realtime parameters"](#) on page 566.

Manual operation: See ["Chain Key Transition Duration \(Step 1\)"](#) on page 177
 See ["Public Key Transition Duration \(Step 1\)"](#) on page 178

[:SOURce<hw>]:BB:GNSS:GALileo:OSNMa:PKEY:TDURATION:STWO <Duration>

Sets the duration of step 2 for Public key transitions.

Parameters:

<Duration> integer
 Range: 1 to 86400
 *RST: 3600

Example: See [Example "To configure Galileo OSNMA realtime parameters"](#) on page 566.

Manual operation: See ["Chain Key Transition Duration \(Step 2\)"](#) on page 177
 See ["Public Key Transition Duration \(Step 2\)"](#) on page 178

[:SOURCE<hw>] : BB : GNSS : GALileo : OSNMa : PKEY : TOMidnight <TimeOffset>

Sets a time offset of the Public key transitions per day.

Parameters:

<TimeOffset> integer
 Range: 0 to 86400
 *RST: 10800

Example: See [Example "To configure Galileo OSNMA realtime parameters"](#) on page 566.

[:SOURCE<hw>] : BB : GNSS : GALileo : OSNMa : RKEY : NTDay <TransPerDay>

Sets the number of root key transitions per day.

Parameters:

<TransPerDay> integer
 Range: 1 to 24
 *RST: 4

Example: See [Example "To configure Galileo OSNMA realtime parameters"](#) on page 566.

Manual operation: See ["Number of Root Key Transitions per Day"](#) on page 177
 See ["Number of Public Key Transitions per Day"](#) on page 177

[:SOURCE<hw>] : BB : GNSS : GALileo : OSNMa : RKEY : TOMidnight <TimeOffset>

Sets a time offset of the TESLA chain transitions per day.

Parameters:

<TimeOffset> integer
 Range: 0 to 86400
 Increment: 3600
 *RST: 10800

Example: See [Example "To configure Galileo OSNMA realtime parameters"](#) on page 566.

Manual operation: See ["Time Offset of Root Key Transition vs. Midnight"](#) on page 177
See ["Time Offset of Public Key Transition vs. Midnight"](#) on page 178

[:SOURCE<hw>]:BB:GNSS:GALileo:OSNMa:SPReemption <Status>

Enable the status preemption.

Parameters:

<Status> 1 | ON | 0 | OFF

*RST: 0

Example: See [Example "To configure Galileo OSNMA realtime parameters"](#) on page 566.

Manual operation: See ["Status Preemption"](#) on page 176

[:SOURCE<hw>]:BB:GNSS:GALileo:OSNMa:TMODe <TransitionMode>

Sets the OSNMA transition mode.

These modes define the provision for the Public Key, TESLA chain and Alert Message. Also, the modes determine the OSNMA status transitions.

Parameters:

<TransitionMode> PRENewal | PREVocation | TRENewal | TREVocation | MRENewal | ALERT

PRENewal

Public key renewal mode

PREVocation

Public key revocation mode

TRENewal

TESLA chain renewal mode

TREVocation

TESLA chain revocation mode

MRENewal

Merkle tree renewal mode

ALERT

Alert message mode

*RST: TRENewal

Example: See [Example "To configure Galileo OSNMA realtime parameters"](#) on page 566.

Manual operation: See ["Transition Mode"](#) on page 172

[:SOURCE<hw>]:BB:GNSS:GALileo:OSNMa:TS <Value>

Sets the bits in the 4-bit Tag Size (TS) field.

Parameters:

<Value> 5 | 6 | 7 | 8 | 9
 *RST: 5

Example:

See [Example "To configure Galileo OSNMA realtime parameters"](#) on page 566.

Manual operation: See ["TS"](#) on page 173

22.15 SBAS corrections

Option: R&S SMW-K106

Suffix SVID<ch>

The value of the SVID<ch> suffix corresponds to PRNs for the SBAS regional system. The value ranges from SVID120 (PRN 120) to SVID158 (PRN 158). In the following, the default constellations of all SBAS including assigned PRNs are listed:

- EGNOS: { 120, 123, 124, 126, 131, 136 }
- WAAS: { 122, 133, 134, 135, 138, 0 }
- MSAS: { 129, 137, 0, 0, 0, 0 }
- GAGAN: { 127, 128, 0, 0, 0, 0 }

You can map up to six PRNs with each SBAS, see [Example "Mapping SBAS PRN to an SBAS system"](#) on page 575.

Example: Enabling SBAS and applying SBAS corrections

```
SOURce1:BB:GNSS:SYSTEM:GPS:STATe 1
SOURce1:BB:GNSS:SYSTEM:SBAS:EGNOS:STATe 1
SOURce1:BB:GNSS:ECMode SYNC

SOURce1:BB:GNSS:SYSTEM:SBAS:EGNOS:NMEsSage:NAV:PRN1:STATe 1
SOURce1:BB:GNSS:SYSTEM:SBAS:EGNOS:NMEsSage:NAV:PRN120:STATe 1
SOURce1:BB:GNSS:SYSTEM:SBAS:EGNOS:NMEsSage:NAV:PRN126:STATe 1
SOURce1:BB:GNSS:SYSTEM:SBAS:EGNOS:NMEsSage:NAV:ALManac:STATe 1
SOURce1:BB:GNSS:SYSTEM:SBAS:EGNOS:NMEsSage:NAV:ALManac:PERiod 200
SOURce1:BB:GNSS:STATe ON
```

Example: Mapping SBAS PRN to an SBAS system

This example shows, how to map individual PRNs to the EGNOS SBAS. Mapping to other SBAS is analogous.

```
// *****
// Assign, for example PRM 120 to PRN 125 to EGNOS SBAS.
// *****
SOURCE1:BB:GNSS:SVID120:SBAS:SYSTEM EGNOS
SOURCE1:BB:GNSS:SVID121:SBAS:SYSTEM EGNOS
SOURCE1:BB:GNSS:SVID122:SBAS:SYSTEM EGNOS
SOURCE1:BB:GNSS:SVID123:SBAS:SYSTEM EGNOS
SOURCE1:BB:GNSS:SVID124:SBAS:SYSTEM EGNOS
SOURCE1:BB:GNSS:SVID125:SBAS:SYSTEM EGNOS
// Assigning the sixth PRN 126 to EGNOS is not possible. The maximum simulation
// capacity of 6 SVs for EGNOS is reached.
SOURCE1:BB:GNSS:SVID126:SBAS:SYSTEM EGNOS
SOURCE1:BB:GNSS:SVID126:SBAS:SYSTEM?
// Reponse: "NONE"
// PRN 126 is excluded from all SBAS constellations.
```

SBAS satellites and their orbit and clock simulated and broadcasted parameters are defined in the same way as the parameters of all other GNSS systems. The same is true also for the configuration of pseudorange errors, echos, power and modulation control and the time conversion settings.

Corresponding remote control commands are thus described together with the commands of the other GNSS systems, see:

- [Chapter 22.2, "System and signal commands"](#), on page 361
- [Chapter 22.11, "Satellites constellation"](#), on page 438
- [Chapter 22.12, "Signals and power configuration per satellite"](#), on page 448
- [Chapter 22.8, "Static multipath configuration"](#), on page 415
- [Chapter 22.13.1, "Simulated orbit, orbit perturbation and clock commands"](#), on page 480
- [Chapter 22.13.2, "Pseudorange commands"](#), on page 491
- [Chapter 22.13.3, "Orbit, clock, system, time conversion and ionospheric errors"](#), on page 500
- [Chapter 22.3, "Time conversion configuration"](#), on page 366
- [Chapter 22.16, "Signal dynamics"](#), on page 585

Example: Importing SBAS correction data files

Load user-defined SBAS corrections via import of *.nstb or *.ems files. For a detailed example of a file import procedure, see [Example "Importing grid files"](#) on page 428.

```
SOURCE1:BB:GNSS:SV:IMPORT:SBAS:EGNOS:ADD:FILE:EMS
"/var/user/gnss/PRN120_y2018_d067_h12.ems"
SOURCE1:BB:GNSS:SV:IMPORT:SBAS:EGNOS:EXECUTE
```

Commands:

[SOURce<hw>]:BB:GNSS:SVID<ch>:SBAS:SYSTem.....	578
[SOURce<hw>]:BB:GNSS:SYSTem:SBAS:GAGAN:NMEssage:NAV:PRN<ch>:STATe.....	578
[SOURce<hw>]:BB:GNSS:SYSTem:SBAS:MSAS:NMEssage:NAV:PRN<ch>:STATe.....	578
[SOURce<hw>]:BB:GNSS:SYSTem:SBAS:WAAS:NMEssage:NAV:PRN<ch>:STATe.....	578
[SOURce<hw>]:BB:GNSS:SYSTem:SBAS:EGNOS:NMEssage:NAV:PRN<ch>:STATe.....	578
[SOURce<hw>]:BB:GNSS:SYSTem:SBAS:GAGAN:NMEssage:NAV:ALManac:STATe.....	579
[SOURce<hw>]:BB:GNSS:SYSTem:SBAS:GAGAN:NMEssage:NAV:CECovariance: STATe.....	579
[SOURce<hw>]:BB:GNSS:SYSTem:SBAS:GAGAN:NMEssage:NAV:DFACtor:STATe.....	579
[SOURce<hw>]:BB:GNSS:SYSTem:SBAS:GAGAN:NMEssage:NAV:FCDegradation: STATe.....	579
[SOURce<hw>]:BB:GNSS:SYSTem:SBAS:GAGAN:NMEssage:NAV:FCORrection:STATe....	579
[SOURce<hw>]:BB:GNSS:SYSTem:SBAS:GAGAN:NMEssage:NAV:IGRid:STATe.....	579
[SOURce<hw>]:BB:GNSS:SYSTem:SBAS:GAGAN:NMEssage:NAV:LTCorrection:STATe....	579
[SOURce<hw>]:BB:GNSS:SYSTem:SBAS:GAGAN:NMEssage:NAV:PRNMask:STATe.....	579
[SOURce<hw>]:BB:GNSS:SYSTem:SBAS:GAGAN:NMEssage:NAV:RINex:STATe.....	579
[SOURce<hw>]:BB:GNSS:SYSTem:SBAS:GAGAN:NMEssage:NAV:SERVice:STATe.....	579
[SOURce<hw>]:BB:GNSS:SYSTem:SBAS:GAGAN:NMEssage:NAV:UTCOffset:STATe?.....	579
[SOURce<hw>]:BB:GNSS:SYSTem:SBAS:MSAS:NMEssage:NAV:ALManac:STATe.....	579
[SOURce<hw>]:BB:GNSS:SYSTem:SBAS:MSAS:NMEssage:NAV:CECovariance:STATe....	579
[SOURce<hw>]:BB:GNSS:SYSTem:SBAS:MSAS:NMEssage:NAV:DFACtor:STATe.....	579
[SOURce<hw>]:BB:GNSS:SYSTem:SBAS:MSAS:NMEssage:NAV:FCDegradation:STATe...	579
[SOURce<hw>]:BB:GNSS:SYSTem:SBAS:MSAS:NMEssage:NAV:FCORrection:STATe.....	579
[SOURce<hw>]:BB:GNSS:SYSTem:SBAS:MSAS:NMEssage:NAV:IGRid:STATe.....	580
[SOURce<hw>]:BB:GNSS:SYSTem:SBAS:MSAS:NMEssage:NAV:LTCorrection:STATe.....	580
[SOURce<hw>]:BB:GNSS:SYSTem:SBAS:MSAS:NMEssage:NAV:PRNMask:STATe.....	580
[SOURce<hw>]:BB:GNSS:SYSTem:SBAS:MSAS:NMEssage:NAV:RINex:STATe.....	580
[SOURce<hw>]:BB:GNSS:SYSTem:SBAS:MSAS:NMEssage:NAV:SERVice:STATe.....	580
[SOURce<hw>]:BB:GNSS:SYSTem:SBAS:MSAS:NMEssage:NAV:UTCOffset:STATe?.....	580
[SOURce<hw>]:BB:GNSS:SYSTem:SBAS:WAAS:NMEssage:NAV:ALManac:STATe.....	580
[SOURce<hw>]:BB:GNSS:SYSTem:SBAS:WAAS:NMEssage:NAV:CECovariance:STATe....	580
[SOURce<hw>]:BB:GNSS:SYSTem:SBAS:WAAS:NMEssage:NAV:DFACtor:STATe.....	580
[SOURce<hw>]:BB:GNSS:SYSTem:SBAS:WAAS:NMEssage:NAV:FCDegradation:STATe...	580
[SOURce<hw>]:BB:GNSS:SYSTem:SBAS:WAAS:NMEssage:NAV:FCORrection:STATe.....	580
[SOURce<hw>]:BB:GNSS:SYSTem:SBAS:WAAS:NMEssage:NAV:IGRid:STATe.....	580
[SOURce<hw>]:BB:GNSS:SYSTem:SBAS:WAAS:NMEssage:NAV:LTCorrection:STATe.....	580
[SOURce<hw>]:BB:GNSS:SYSTem:SBAS:WAAS:NMEssage:NAV:PRNMask:STATe.....	580
[SOURce<hw>]:BB:GNSS:SYSTem:SBAS:WAAS:NMEssage:NAV:RINex:STATe.....	580
[SOURce<hw>]:BB:GNSS:SYSTem:SBAS:WAAS:NMEssage:NAV:SERVice:STATe.....	580
[SOURce<hw>]:BB:GNSS:SYSTem:SBAS:WAAS:NMEssage:NAV:UTCOffset:STATe?.....	580
[SOURce<hw>]:BB:GNSS:SYSTem:SBAS:EGNOS:NMEssage:NAV:CECovariance: STATe.....	580
[SOURce<hw>]:BB:GNSS:SYSTem:SBAS:EGNOS:NMEssage:NAV:DFACtor:STATe.....	580
[SOURce<hw>]:BB:GNSS:SYSTem:SBAS:EGNOS:NMEssage:NAV:FCDegradation: STATe.....	580
[SOURce<hw>]:BB:GNSS:SYSTem:SBAS:EGNOS:NMEssage:NAV:FCORrection:STATe...	580
[SOURce<hw>]:BB:GNSS:SYSTem:SBAS:EGNOS:NMEssage:NAV:IGRid:STATe.....	580
[SOURce<hw>]:BB:GNSS:SYSTem:SBAS:EGNOS:NMEssage:NAV:LTCorrection:STATe....	580

SBAS corrections

[:SOURce<hw>]:BB:GNSS:SYSTem:SBAS:EGNOS:NMEssage:NAV:PRNMask:STATe..... 580

[:SOURce<hw>]:BB:GNSS:SYSTem:SBAS:EGNOS:NMEssage:NAV:RINex:STATe..... 580

[:SOURce<hw>]:BB:GNSS:SYSTem:SBAS:EGNOS:NMEssage:NAV:SERvice:STATe..... 581

[:SOURce<hw>]:BB:GNSS:SYSTem:SBAS:EGNOS:NMEssage:NAV:UTCOffset:STATe?..... 581

[:SOURce<hw>]:BB:GNSS:SYSTem:SBAS:EGNOS:NMEssage:NAV:ALManac:STATe..... 581

[:SOURce<hw>]:BB:GNSS:SYSTem:SBAS:GAGAN:NMEssage:NAV:ALManac:PERiod..... 581

[:SOURce<hw>]:BB:GNSS:SYSTem:SBAS:GAGAN:NMEssage:NAV:CECovariance:
 PERiod..... 581

[:SOURce<hw>]:BB:GNSS:SYSTem:SBAS:GAGAN:NMEssage:NAV:DFActor:PERiod..... 581

[:SOURce<hw>]:BB:GNSS:SYSTem:SBAS:GAGAN:NMEssage:NAV:FCDegradation:
 PERiod..... 581

[:SOURce<hw>]:BB:GNSS:SYSTem:SBAS:GAGAN:NMEssage:NAV:FCORrection:PERiod.. 581

[:SOURce<hw>]:BB:GNSS:SYSTem:SBAS:GAGAN:NMEssage:NAV:IGRid:PERiod..... 581

[:SOURce<hw>]:BB:GNSS:SYSTem:SBAS:GAGAN:NMEssage:NAV:LTCorrection:PERiod.. 581

[:SOURce<hw>]:BB:GNSS:SYSTem:SBAS:GAGAN:NMEssage:NAV:PRNMask:PERiod..... 581

[:SOURce<hw>]:BB:GNSS:SYSTem:SBAS:GAGAN:NMEssage:NAV:RINex:PERiod..... 581

[:SOURce<hw>]:BB:GNSS:SYSTem:SBAS:GAGAN:NMEssage:NAV:SERvice:PERiod..... 581

[:SOURce<hw>]:BB:GNSS:SYSTem:SBAS:GAGAN:NMEssage:NAV:UTCOffset:PERiod..... 581

[:SOURce<hw>]:BB:GNSS:SYSTem:SBAS:MSAS:NMEssage:NAV:ALManac:PERiod..... 581

[:SOURce<hw>]:BB:GNSS:SYSTem:SBAS:MSAS:NMEssage:NAV:CECovariance:PERiod.. 581

[:SOURce<hw>]:BB:GNSS:SYSTem:SBAS:MSAS:NMEssage:NAV:DFActor:PERiod..... 581

[:SOURce<hw>]:BB:GNSS:SYSTem:SBAS:MSAS:NMEssage:NAV:FCDegradation:
 PERiod..... 581

[:SOURce<hw>]:BB:GNSS:SYSTem:SBAS:MSAS:NMEssage:NAV:FCORrection:PERiod.... 581

[:SOURce<hw>]:BB:GNSS:SYSTem:SBAS:MSAS:NMEssage:NAV:IGRid:PERiod..... 581

[:SOURce<hw>]:BB:GNSS:SYSTem:SBAS:MSAS:NMEssage:NAV:LTCorrection:PERiod..... 582

[:SOURce<hw>]:BB:GNSS:SYSTem:SBAS:MSAS:NMEssage:NAV:PRNMask:PERiod..... 582

[:SOURce<hw>]:BB:GNSS:SYSTem:SBAS:MSAS:NMEssage:NAV:RINex:PERiod..... 582

[:SOURce<hw>]:BB:GNSS:SYSTem:SBAS:MSAS:NMEssage:NAV:SERvice:PERiod..... 582

[:SOURce<hw>]:BB:GNSS:SYSTem:SBAS:MSAS:NMEssage:NAV:UTCOffset:PERiod..... 582

[:SOURce<hw>]:BB:GNSS:SYSTem:SBAS:WAAS:NMEssage:NAV:ALManac:PERiod..... 582

[:SOURce<hw>]:BB:GNSS:SYSTem:SBAS:WAAS:NMEssage:NAV:CECovariance:PERiod.. 582

[:SOURce<hw>]:BB:GNSS:SYSTem:SBAS:WAAS:NMEssage:NAV:DFActor:PERiod..... 582

[:SOURce<hw>]:BB:GNSS:SYSTem:SBAS:WAAS:NMEssage:NAV:FCDegradation:
 PERiod..... 582

[:SOURce<hw>]:BB:GNSS:SYSTem:SBAS:WAAS:NMEssage:NAV:FCORrection:PERiod.... 582

[:SOURce<hw>]:BB:GNSS:SYSTem:SBAS:WAAS:NMEssage:NAV:IGRid:PERiod..... 582

[:SOURce<hw>]:BB:GNSS:SYSTem:SBAS:WAAS:NMEssage:NAV:LTCorrection:PERiod.... 582

[:SOURce<hw>]:BB:GNSS:SYSTem:SBAS:WAAS:NMEssage:NAV:PRNMask:PERiod..... 582

[:SOURce<hw>]:BB:GNSS:SYSTem:SBAS:WAAS:NMEssage:NAV:RINex:PERiod..... 582

[:SOURce<hw>]:BB:GNSS:SYSTem:SBAS:WAAS:NMEssage:NAV:SERvice:PERiod..... 582

[:SOURce<hw>]:BB:GNSS:SYSTem:SBAS:WAAS:NMEssage:NAV:UTCOffset:PERiod..... 582

[:SOURce<hw>]:BB:GNSS:SYSTem:SBAS:EGNOS:NMEssage:NAV:CECovariance:
 PERiod..... 582

[:SOURce<hw>]:BB:GNSS:SYSTem:SBAS:EGNOS:NMEssage:NAV:DFActor:PERiod..... 582

[:SOURce<hw>]:BB:GNSS:SYSTem:SBAS:EGNOS:NMEssage:NAV:FCDegradation:
 PERiod..... 582

[:SOURce<hw>]:BB:GNSS:SYSTem:SBAS:EGNOS:NMEssage:NAV:FCORrection:PERiod.. 582

[:SOURce<hw>]:BB:GNSS:SYSTem:SBAS:EGNOS:NMEssage:NAV:IGRid:PERiod..... 582

[:SOURce<hw>]:BB:GNSS:SYSTem:SBAS:EGNOS:NMEssage:NAV:LTCorrection:PERiod.. 582

<code>[:SOURCE<hw>]:BB:GNSS:SYSTEM:SBAS:EGNOS:NMESSsage:NAV:PRNMask:PERiod.....</code>	582
<code>[:SOURCE<hw>]:BB:GNSS:SYSTEM:SBAS:EGNOS:NMESSsage:NAV:RINex:PERiod.....</code>	582
<code>[:SOURCE<hw>]:BB:GNSS:SYSTEM:SBAS:EGNOS:NMESSsage:NAV:SERVICE:PERiod.....</code>	582
<code>[:SOURCE<hw>]:BB:GNSS:SYSTEM:SBAS:EGNOS:NMESSsage:NAV:UTCOffset:PERiod.....</code>	583
<code>[:SOURCE<hw>]:BB:GNSS:SYSTEM:SBAS:EGNOS:NMESSsage:NAV:ALManac:PERiod.....</code>	583
<code>[:SOURCE<hw>]:BB:GNSS:SV:IMPorT:SBAS:EGNOS:ADD:FILE.....</code>	583
<code>[:SOURCE<hw>]:BB:GNSS:SV:IMPorT:SBAS:WAAS:ADD:FILE.....</code>	583
<code>[:SOURCE<hw>]:BB:GNSS:SV:IMPorT:SBAS:EGNOS:ADD:DIR.....</code>	583
<code>[:SOURCE<hw>]:BB:GNSS:SV:IMPorT:SBAS:WAAS:ADD:DIR.....</code>	583
<code>[:SOURCE<hw>]:BB:GNSS:SV:IMPorT:SBAS:EGNOS:LIST?.....</code>	584
<code>[:SOURCE<hw>]:BB:GNSS:SV:IMPorT:SBAS:WAAS:LIST?.....</code>	584
<code>[:SOURCE<hw>]:BB:GNSS:SV:IMPorT:SBAS:EGNOS:EXECute.....</code>	584
<code>[:SOURCE<hw>]:BB:GNSS:SV:IMPorT:SBAS:WAAS:EXECute.....</code>	584
<code>[:SOURCE<hw>]:BB:GNSS:SV:IMPorT:SBAS:EGNOS:REMOve:ALL.....</code>	584
<code>[:SOURCE<hw>]:BB:GNSS:SV:IMPorT:SBAS:WAAS:REMOve:ALL.....</code>	584
<code>[:SOURCE<hw>]:BB:GNSS:SV:IMPorT:SBAS:EGNOS:REMOve:FILE<ch>.....</code>	585
<code>[:SOURCE<hw>]:BB:GNSS:SV:IMPorT:SBAS:WAAS:REMOve:FILE<ch>.....</code>	585

`[:SOURCE<hw>]:BB:GNSS:SVID<ch>:SBAS:SYSTEM <SbasSystem>`

Maps the SBAS space vehicle, the pseudorandom number (PRN), with the SBAS system.

If a PRN is mapped to an SBAS, this PRN is not available in the other SBAS.

Parameters:

`<SbasSystem>` EGNOS | WAAS | MSAS | GAGAN | NONE
EGNOS|WAAS|MSAS|GAGAN
 SBAS available for mapping
NONE
 Space vehicle is excluded from all SBAS constellations.

Example: See [Example "Mapping SBAS PRN to an SBAS system"](#) on page 575.

Manual operation: See ["SBAS System"](#) on page 245

`[:SOURCE<hw>]:BB:GNSS:SYSTEM:SBAS:GAGAN:NMESSsage:NAV:PRN<ch>:
 STATE <State>`
`[:SOURCE<hw>]:BB:GNSS:SYSTEM:SBAS:MSAS:NMESSsage:NAV:PRN<ch>:
 STATE <State>`
`[:SOURCE<hw>]:BB:GNSS:SYSTEM:SBAS:WAAS:NMESSsage:NAV:PRN<ch>:
 STATE <State>`
`[:SOURCE<hw>]:BB:GNSS:SYSTEM:SBAS:EGNOS:NMESSsage:NAV:PRN<ch>:
 STATE <State>`

Enables an SV ID/ SV PRN.

Suffix:

PRN<ch> GPS SV ID or SBAS PRN:
 GPS: 1 to 37
 EGNOS: {120, 124, 126, 131, 136}
 WAAS: {122, 133, 134, 135, 138}
 MSAS: {129, 137, 0, 0, 0}
 GAGAN: {127, 128, 0, 0, 0}

Parameters:

<State> 0 | 1 | OFF | ON
 *RST: 0

Example: See [Example"Enabling SBAS and applying SBAS corrections"](#) on page 574.

Manual operation: See ["GNSS PRNs/SBAS PRNs, State"](#) on page 255

```
[ :SOURce<hw>]:BB:GNSS:SYSTEM:SBAS:GAGAN:NMESsage:NAV:ALManac:
  STATE <State>
[ :SOURce<hw>]:BB:GNSS:SYSTEM:SBAS:GAGAN:NMESsage:NAV:
  CECovariance:STATE <State>
[ :SOURce<hw>]:BB:GNSS:SYSTEM:SBAS:GAGAN:NMESsage:NAV:DFACtor:
  STATE <State>
[ :SOURce<hw>]:BB:GNSS:SYSTEM:SBAS:GAGAN:NMESsage:NAV:
  FCDegradation:STATE <State>
[ :SOURce<hw>]:BB:GNSS:SYSTEM:SBAS:GAGAN:NMESsage:NAV:
  FCORrection:STATE <State>
[ :SOURce<hw>]:BB:GNSS:SYSTEM:SBAS:GAGAN:NMESsage:NAV:IGRid:STATE
  <State>
[ :SOURce<hw>]:BB:GNSS:SYSTEM:SBAS:GAGAN:NMESsage:NAV:
  LTCorrection:STATE <State>
[ :SOURce<hw>]:BB:GNSS:SYSTEM:SBAS:GAGAN:NMESsage:NAV:PRNMask:
  STATE <State>
[ :SOURce<hw>]:BB:GNSS:SYSTEM:SBAS:GAGAN:NMESsage:NAV:RINex:STATE
  <State>
[ :SOURce<hw>]:BB:GNSS:SYSTEM:SBAS:GAGAN:NMESsage:NAV:SERVice:
  STATE <State>
[ :SOURce<hw>]:BB:GNSS:SYSTEM:SBAS:GAGAN:NMESsage:NAV:UTCoffset:
  STATE?
[ :SOURce<hw>]:BB:GNSS:SYSTEM:SBAS:MSAS:NMESsage:NAV:ALManac:
  STATE <State>
[ :SOURce<hw>]:BB:GNSS:SYSTEM:SBAS:MSAS:NMESsage:NAV:CECovariance:
  STATE <State>
[ :SOURce<hw>]:BB:GNSS:SYSTEM:SBAS:MSAS:NMESsage:NAV:DFACtor:
  STATE <State>
[ :SOURce<hw>]:BB:GNSS:SYSTEM:SBAS:MSAS:NMESsage:NAV:
  FCDegradation:STATE <State>
[ :SOURce<hw>]:BB:GNSS:SYSTEM:SBAS:MSAS:NMESsage:NAV:FCORrection:
  STATE <State>
```

```

[:SOURce<hw>]:BB:GNSS:SYSTEM:SBAS:MSAS:NMESSage:NAV:IGRid:STATE
<State>
[:SOURce<hw>]:BB:GNSS:SYSTEM:SBAS:MSAS:NMESSage:NAV:LTCorrection:
STATE <State>
[:SOURce<hw>]:BB:GNSS:SYSTEM:SBAS:MSAS:NMESSage:NAV:PRNMask:
STATE <State>
[:SOURce<hw>]:BB:GNSS:SYSTEM:SBAS:MSAS:NMESSage:NAV:RINex:STATE
<State>
[:SOURce<hw>]:BB:GNSS:SYSTEM:SBAS:MSAS:NMESSage:NAV:SERVICE:
STATE <State>
[:SOURce<hw>]:BB:GNSS:SYSTEM:SBAS:MSAS:NMESSage:NAV:UTCOffset:
STATE?
[:SOURce<hw>]:BB:GNSS:SYSTEM:SBAS:WAAS:NMESSage:NAV:ALManac:
STATE <State>
[:SOURce<hw>]:BB:GNSS:SYSTEM:SBAS:WAAS:NMESSage:NAV:CECovariance:
STATE <State>
[:SOURce<hw>]:BB:GNSS:SYSTEM:SBAS:WAAS:NMESSage:NAV:DFACTor:
STATE <State>
[:SOURce<hw>]:BB:GNSS:SYSTEM:SBAS:WAAS:NMESSage:NAV:
FCDegradation:STATE <State>
[:SOURce<hw>]:BB:GNSS:SYSTEM:SBAS:WAAS:NMESSage:NAV:FCORrection:
STATE <State>
[:SOURce<hw>]:BB:GNSS:SYSTEM:SBAS:WAAS:NMESSage:NAV:IGRid:STATE
<State>
[:SOURce<hw>]:BB:GNSS:SYSTEM:SBAS:WAAS:NMESSage:NAV:LTCorrection:
STATE <State>
[:SOURce<hw>]:BB:GNSS:SYSTEM:SBAS:WAAS:NMESSage:NAV:PRNMask:
STATE <State>
[:SOURce<hw>]:BB:GNSS:SYSTEM:SBAS:WAAS:NMESSage:NAV:RINex:STATE
<State>
[:SOURce<hw>]:BB:GNSS:SYSTEM:SBAS:WAAS:NMESSage:NAV:SERVICE:
STATE <State>
[:SOURce<hw>]:BB:GNSS:SYSTEM:SBAS:WAAS:NMESSage:NAV:UTCOffset:
STATE?
[:SOURce<hw>]:BB:GNSS:SYSTEM:SBAS:EGNOS:NMESSage:NAV:
CECovariance:STATE <State>
[:SOURce<hw>]:BB:GNSS:SYSTEM:SBAS:EGNOS:NMESSage:NAV:DFACTor:
STATE <State>
[:SOURce<hw>]:BB:GNSS:SYSTEM:SBAS:EGNOS:NMESSage:NAV:
FCDegradation:STATE <State>
[:SOURce<hw>]:BB:GNSS:SYSTEM:SBAS:EGNOS:NMESSage:NAV:FCORrection:
STATE <State>
[:SOURce<hw>]:BB:GNSS:SYSTEM:SBAS:EGNOS:NMESSage:NAV:IGRid:STATE
<State>
[:SOURce<hw>]:BB:GNSS:SYSTEM:SBAS:EGNOS:NMESSage:NAV:
LTCorrection:STATE <State>
[:SOURce<hw>]:BB:GNSS:SYSTEM:SBAS:EGNOS:NMESSage:NAV:PRNMask:
STATE <State>
[:SOURce<hw>]:BB:GNSS:SYSTEM:SBAS:EGNOS:NMESSage:NAV:RINex:STATE
<State>

```

```
[:SOURce<hw>]:BB:GNSS:SYSTem:SBAS:EGNOS:NMESsage:NAV:SERvice:
  STATE <State>
[:SOURce<hw>]:BB:GNSS:SYSTem:SBAS:EGNOS:NMESsage:NAV:UTCoffset:
  STATE?
[:SOURce<hw>]:BB:GNSS:SYSTem:SBAS:EGNOS:NMESsage:NAV:ALManac:
  STATE <State>
```

Enables generation of the particular SBAS correction data.

Parameters:

<State> 1 | ON | 0 | OFF

Example: See [Example "Enabling SBAS and applying SBAS corrections"](#) on page 574.

Manual operation: See ["Message Schedule"](#) on page 264

```
[:SOURce<hw>]:BB:GNSS:SYSTem:SBAS:GAGAN:NMESsage:NAV:ALManac:
  PERiod <Interval>
[:SOURce<hw>]:BB:GNSS:SYSTem:SBAS:GAGAN:NMESsage:NAV:
  CECovariance:PERiod <Interval>
[:SOURce<hw>]:BB:GNSS:SYSTem:SBAS:GAGAN:NMESsage:NAV:DFACtor:
  PERiod <Interval>
[:SOURce<hw>]:BB:GNSS:SYSTem:SBAS:GAGAN:NMESsage:NAV:
  FCDegradation:PERiod <Interval>
[:SOURce<hw>]:BB:GNSS:SYSTem:SBAS:GAGAN:NMESsage:NAV:
  FCORrection:PERiod <Interval>
[:SOURce<hw>]:BB:GNSS:SYSTem:SBAS:GAGAN:NMESsage:NAV:IGRid:
  PERiod <Interval>
[:SOURce<hw>]:BB:GNSS:SYSTem:SBAS:GAGAN:NMESsage:NAV:
  LTCORrection:PERiod <Interval>
[:SOURce<hw>]:BB:GNSS:SYSTem:SBAS:GAGAN:NMESsage:NAV:PRNMask:
  PERiod <Interval>
[:SOURce<hw>]:BB:GNSS:SYSTem:SBAS:GAGAN:NMESsage:NAV:RINex:
  PERiod <Interval>
[:SOURce<hw>]:BB:GNSS:SYSTem:SBAS:GAGAN:NMESsage:NAV:SERvice:
  PERiod <Interval>
[:SOURce<hw>]:BB:GNSS:SYSTem:SBAS:GAGAN:NMESsage:NAV:UTCoffset:
  PERiod <UtcOffsetPeriod>
[:SOURce<hw>]:BB:GNSS:SYSTem:SBAS:MSAS:NMESsage:NAV:ALManac:
  PERiod <Interval>
[:SOURce<hw>]:BB:GNSS:SYSTem:SBAS:MSAS:NMESsage:NAV:CECovariance:
  PERiod <Interval>
[:SOURce<hw>]:BB:GNSS:SYSTem:SBAS:MSAS:NMESsage:NAV:DFACtor:
  PERiod <Interval>
[:SOURce<hw>]:BB:GNSS:SYSTem:SBAS:MSAS:NMESsage:NAV:
  FCDegradation:PERiod <Interval>
[:SOURce<hw>]:BB:GNSS:SYSTem:SBAS:MSAS:NMESsage:NAV:FCORrection:
  PERiod <Interval>
[:SOURce<hw>]:BB:GNSS:SYSTem:SBAS:MSAS:NMESsage:NAV:IGRid:PERiod
  <Interval>
```

```

[:SOURce<hw>]:BB:GNSS:SYSTem:SBAS:MSAS:NMESsage:NAV:LTCorrection:
  PERiod <Interval>
[:SOURce<hw>]:BB:GNSS:SYSTem:SBAS:MSAS:NMESsage:NAV:PRNMask:
  PERiod <Interval>
[:SOURce<hw>]:BB:GNSS:SYSTem:SBAS:MSAS:NMESsage:NAV:RINex:PERiod
  <Interval>
[:SOURce<hw>]:BB:GNSS:SYSTem:SBAS:MSAS:NMESsage:NAV:SERvice:
  PERiod <Interval>
[:SOURce<hw>]:BB:GNSS:SYSTem:SBAS:MSAS:NMESsage:NAV:UTCOffset:
  PERiod <UtcOffsetPeriod>
[:SOURce<hw>]:BB:GNSS:SYSTem:SBAS:WAAS:NMESsage:NAV:ALManac:
  PERiod <Interval>
[:SOURce<hw>]:BB:GNSS:SYSTem:SBAS:WAAS:NMESsage:NAV:CECovariance:
  PERiod <Interval>
[:SOURce<hw>]:BB:GNSS:SYSTem:SBAS:WAAS:NMESsage:NAV:DFACTOR:
  PERiod <Interval>
[:SOURce<hw>]:BB:GNSS:SYSTem:SBAS:WAAS:NMESsage:NAV:
  FCDegradation:PERiod <Interval>
[:SOURce<hw>]:BB:GNSS:SYSTem:SBAS:WAAS:NMESsage:NAV:FCORrection:
  PERiod <Interval>
[:SOURce<hw>]:BB:GNSS:SYSTem:SBAS:WAAS:NMESsage:NAV:IGRid:PERiod
  <Interval>
[:SOURce<hw>]:BB:GNSS:SYSTem:SBAS:WAAS:NMESsage:NAV:LTCorrection:
  PERiod <Interval>
[:SOURce<hw>]:BB:GNSS:SYSTem:SBAS:WAAS:NMESsage:NAV:PRNMask:
  PERiod <Interval>
[:SOURce<hw>]:BB:GNSS:SYSTem:SBAS:WAAS:NMESsage:NAV:RINex:PERiod
  <Interval>
[:SOURce<hw>]:BB:GNSS:SYSTem:SBAS:WAAS:NMESsage:NAV:SERvice:
  PERiod <Interval>
[:SOURce<hw>]:BB:GNSS:SYSTem:SBAS:WAAS:NMESsage:NAV:UTCOffset:
  PERiod <UtcOffsetPeriod>
[:SOURce<hw>]:BB:GNSS:SYSTem:SBAS:EGNOS:NMESsage:NAV:
  CECovariance:PERiod <Interval>
[:SOURce<hw>]:BB:GNSS:SYSTem:SBAS:EGNOS:NMESsage:NAV:DFACTOR:
  PERiod <Interval>
[:SOURce<hw>]:BB:GNSS:SYSTem:SBAS:EGNOS:NMESsage:NAV:
  FCDegradation:PERiod <Interval>
[:SOURce<hw>]:BB:GNSS:SYSTem:SBAS:EGNOS:NMESsage:NAV:FCORrection:
  PERiod <Interval>
[:SOURce<hw>]:BB:GNSS:SYSTem:SBAS:EGNOS:NMESsage:NAV:IGRid:
  PERiod <Interval>
[:SOURce<hw>]:BB:GNSS:SYSTem:SBAS:EGNOS:NMESsage:NAV:
  LTCorrection:PERiod <Interval>
[:SOURce<hw>]:BB:GNSS:SYSTem:SBAS:EGNOS:NMESsage:NAV:PRNMask:
  PERiod <Interval>
[:SOURce<hw>]:BB:GNSS:SYSTem:SBAS:EGNOS:NMESsage:NAV:RINex:
  PERiod <Interval>
[:SOURce<hw>]:BB:GNSS:SYSTem:SBAS:EGNOS:NMESsage:NAV:SERvice:
  PERiod <Interval>

```

[[:SOURce<hw>]:BB:GNSS:SYSTEM:SBAS:EGNOS:NMESSage:NAV:UTCOffset:PERiod <UtcOffsetPeriod>

[[:SOURce<hw>]:BB:GNSS:SYSTEM:SBAS:EGNOS:NMESSage:NAV:ALManac:PERiod <Interval>

Sets the periodicity of the SBAS message.

Parameters:

<Interval> integer
 Range: 0 to 999
 *RST: 200

Example: See [Example"Enabling SBAS and applying SBAS corrections"](#) on page 574.

Manual operation: See ["Message Schedule"](#) on page 264

[[:SOURce<hw>]:BB:GNSS:SV:IMPort:SBAS:EGNOS:ADD:FILE <Filename>
[[:SOURce<hw>]:BB:GNSS:SV:IMPort:SBAS:WAAS:ADD:FILE <Filename>

Adds

* .ems files for EGNOS correction data

* .nsth files for WAAS correction data

to an import file list.

Setting parameters:

<Filename> string
 The <Filename> string comprises the file directory, filename and extension. For more information about * .ems and * .nsth files, see ["SBAS correction file download"](#) on page 309.

Example: See [Example"Importing SBAS correction data files"](#) on page 575

Usage: Setting only

Manual operation: See ["Add File"](#) on page 312

[[:SOURce<hw>]:BB:GNSS:SV:IMPort:SBAS:EGNOS:ADD:DIR <Directory>
[[:SOURce<hw>]:BB:GNSS:SV:IMPort:SBAS:WAAS:ADD:DIR <Directory>

Adds a set of

* .ems files for EGNOS correction data

* .nsth files for WAAS correction data

to an import file list in one step.

Setting parameters:

<Directory> string
 File path

Example: See [Example "Importing grid files"](#) on page 428 for an analogous procedure.

Usage: Setting only

Manual operation: See ["Add Directory"](#) on page 313

[:SOURce<hw>]:BB:GNSS:SV:IMPOrt:SBAS:EGNOS:LIST?

[:SOURce<hw>]:BB:GNSS:SV:IMPOrt:SBAS:WAAS:LIST?

Queries all

* .ems files for EGNOS correction data

* .nsth files for WAAS correction data

of the import file list in a comma separated list.

Example: See [Example "Importing grid files"](#) on page 428 for an analogous procedure.

Usage: Query only

Manual operation: See ["Input Files"](#) on page 313

[:SOURce<hw>]:BB:GNSS:SV:IMPOrt:SBAS:EGNOS:EXECute

[:SOURce<hw>]:BB:GNSS:SV:IMPOrt:SBAS:WAAS:EXECute

Loads all

* .ems files for EGNOS correction data

* .nsth files for WAAS correction data

from an import file list.

Example: See [Example "Importing SBAS correction data files"](#) on page 575

Usage: Event

Manual operation: See ["Import, Cancel"](#) on page 313

[:SOURce<hw>]:BB:GNSS:SV:IMPOrt:SBAS:EGNOS:REMOve:ALL

[:SOURce<hw>]:BB:GNSS:SV:IMPOrt:SBAS:WAAS:REMOve:ALL

Removes all

* .ems files for EGNOS correction data

* .nsth files for WAAS correction data

from the import files list.

Example: SOURce1:BB:GNSS:SV:IMPOrt:SBAS:WAAS:REMOve:ALL

Usage: Event

Manual operation: See ["Remove File, Remove All"](#) on page 313

```
[:SOURce<hw>]:BB:GNSS:SV:IMPORt:SBAS:EGNOS:REMOve:FILE<ch>
[:SOURce<hw>]:BB:GNSS:SV:IMPORt:SBAS:WAAS:REMOve:FILE<ch>
```

Removes one particular

* .ems file for EGNOS correction data

* .nsth file for WAAS correction data

at the n-th position from the import file list.

Suffix:

<ch> 1 to n

Example:

See [Example "Importing grid files"](#) on page 428 for an analogous procedure.

Usage:

Event

Manual operation:

See ["Remove File, Remove All"](#) on page 313

22.16 Signal dynamics

Example: Configuring the signal dynamics

```
SOURce1:BB:GNSS:TMODe TRAC
SOURce1:BB:GNSS:SYSTem:GPS:STATe 1
SOURce1:BB:GNSS:SYSTem:GPS:SIGNal:L1Band:CA:STATe 1
SOURce1:BB:GNSS:SYSTem:GPS:SIGNal:L1Band:P:STATe 1
SOURce1:BB:GNSS:SYSTem:GPS:SIGNal:L1Band:L1C:STATe 1
SOURce1:BB:GNSS:SVID1:GPS:SIGNal:L1Band:CA:DATA:NMESsage:STATe 0
SOURce1:BB:GNSS:SVID1:GPS:SIGNal:L1Band:CA:DATA:PCODE:STATe 1
SOURce1:BB:GNSS:SVID1:GPS:SIGNal:L1Band:L1C:DATA:NMESsage:STATe 0

SOURce1:BB:GNSS:SVID1:GPS:SDYName:PROFile HIGH
SOURce1:BB:GNSS:SVID1:GPS:SDYName:CPHase 3.14
SOURce1:BB:GNSS:SVID1:GPS:SDYName:PRANge 100
SOURce1:BB:GNSS:SVID1:GPS:SDYName:TOFFset 10
SOURce1:BB:GNSS:SVID1:GPS:SDYName:CONFig USER

SOURce1:BB:GNSS:SVID1:GPS:SDYName:IVELocity 100
SOURce1:BB:GNSS:SVID1:GPS:SDYName:CVPeriod 20
SOURce1:BB:GNSS:SVID1:GPS:SDYName:CAPeriod 40
SOURce1:BB:GNSS:SVID1:GPS:SDYName:ACCel:MAX 10
SOURce1:BB:GNSS:SVID1:GPS:SDYName:JERK:MAX 20
SOURce1:BB:GNSS:SVID1:GPS:SDYName:RPERiod?
// 240
SOURce1:BB:GNSS:STATe 1
```

Commands:

[:SOURce<hw>]:BB:GNSS:SVID<ch>:SBAS:SIGNal:L5Band:EL5S:DATA:NMEssage[: STATE].	589
[:SOURce<hw>]:BB:GNSS:SVID<ch>:SBAS:SIGNal:L1Band:CA:DATA:NMEssage[: STATE].	589
[:SOURce<hw>]:BB:GNSS:SVID<ch>:NAVic:SIGNal:L5Band:SPS:DATA:NMEssage[: STATE].	589
[:SOURce<hw>]:BB:GNSS:SVID<ch>:QZSS:SIGNal:L5Band:L5S:DATA:NMEssage[: STATE].	589
[:SOURce<hw>]:BB:GNSS:SVID<ch>:QZSS:SIGNal:L2Band:L2C:DATA:NMEssage[: STATE].	589
[:SOURce<hw>]:BB:GNSS:SVID<ch>:QZSS:SIGNal:L1Band:CA:DATA:NMEssage[: STATE].	589
[:SOURce<hw>]:BB:GNSS:SVID<ch>:QZSS:SIGNal:L1Band:L1C:DATA:NMEssage[: STATE].	589
[:SOURce<hw>]:BB:GNSS:SVID<ch>:BEIDou:SIGNal:L5Band:B2A:DATA:NMEssage[: STATE].	589
[:SOURce<hw>]:BB:GNSS:SVID<ch>:BEIDou:SIGNal:L5Band:B2B:DATA:NMEssage[: STATE].	589
[:SOURce<hw>]:BB:GNSS:SVID<ch>:BEIDou:SIGNal:L5Band:B2I:DATA:NMEssage[: STATE].	589
[:SOURce<hw>]:BB:GNSS:SVID<ch>:BEIDou:SIGNal:L2Band:B3I:DATA:NMEssage[: STATE].	589
[:SOURce<hw>]:BB:GNSS:SVID<ch>:BEIDou:SIGNal:L1Band:B1C:DATA:NMEssage[: STATE].	589
[:SOURce<hw>]:BB:GNSS:SVID<ch>:BEIDou:SIGNal:L1Band:B1I:DATA:NMEssage[: STATE].	589
[:SOURce<hw>]:BB:GNSS:SVID<ch>:GLONass:SIGNal:L5Band:L3CDma:DATA: NMEssage[:STATE].	589
[:SOURce<hw>]:BB:GNSS:SVID<ch>:GLONass:SIGNal:L2Band:CA:DATA:NMEssage[: STATE].	589
[:SOURce<hw>]:BB:GNSS:SVID<ch>:GLONass:SIGNal:L2Band:L2CDma:DATA: NMEssage[:STATE].	589
[:SOURce<hw>]:BB:GNSS:SVID<ch>:GLONass:SIGNal:L1Band:CA:DATA:NMEssage[: STATE].	589
[:SOURce<hw>]:BB:GNSS:SVID<ch>:GLONass:SIGNal:L1Band:L1CDma:DATA: NMEssage[:STATE].	589
[:SOURce<hw>]:BB:GNSS:SVID<ch>:GALileo:SIGNal:L5Band:E5A:DATA:NMEssage[: STATE].	589
[:SOURce<hw>]:BB:GNSS:SVID<ch>:GALileo:SIGNal:L5Band:E5B:DATA:NMEssage[: STATE].	589
[:SOURce<hw>]:BB:GNSS:SVID<ch>:GALileo:SIGNal:L2Band:E6PRs:DATA: NMEssage[:STATE].	589
[:SOURce<hw>]:BB:GNSS:SVID<ch>:GALileo:SIGNal:L2Band:E6S:DATA:NMEssage[: STATE].	589
[:SOURce<hw>]:BB:GNSS:SVID<ch>:GALileo:SIGNal:L1Band:E1OS:DATA: NMEssage[:STATE].	589
[:SOURce<hw>]:BB:GNSS:SVID<ch>:GALileo:SIGNal:L1Band:E1PRs:DATA: NMEssage[:STATE].	589

[SOURce<hw>]:BB:GNSS:SVID<ch>:GPS:SIGNal:L5Band:L5S:DATA:NMEssage[:STATe]..	590
[SOURce<hw>]:BB:GNSS:SVID<ch>:GPS:SIGNal:L2Band:CA:DATA:NMEssage[:STATe]...	590
[SOURce<hw>]:BB:GNSS:SVID<ch>:GPS:SIGNal:L2Band:L2C:DATA:NMEssage[:STATe]..	590
[SOURce<hw>]:BB:GNSS:SVID<ch>:GPS:SIGNal:L2Band:M:DATA:NMEssage[:STATe].....	590
[SOURce<hw>]:BB:GNSS:SVID<ch>:GPS:SIGNal:L2Band:P:DATA:NMEssage[:STATe].....	590
[SOURce<hw>]:BB:GNSS:SVID<ch>:GPS:SIGNal:L2Band:PY:DATA:NMEssage[:STATe]...	590
[SOURce<hw>]:BB:GNSS:SVID<ch>:GPS:SIGNal:L1Band:L1C:DATA:NMEssage[:STATe]..	590
[SOURce<hw>]:BB:GNSS:SVID<ch>:GPS:SIGNal:L1Band:M:DATA:NMEssage[:STATe].....	590
[SOURce<hw>]:BB:GNSS:SVID<ch>:GPS:SIGNal:L1Band:P:DATA:NMEssage[:STATe].....	590
[SOURce<hw>]:BB:GNSS:SVID<ch>:GPS:SIGNal:L1Band:PY:DATA:NMEssage[:STATe]...	590
[SOURce<hw>]:BB:GNSS:SVID<ch>:GPS:SIGNal:L1Band:CA:DATA:NMEssage[:STATe]...	590
[SOURce<hw>]:BB:GNSS:SVID<ch>:SBAS:SDYNamics:PROFile.....	590
[SOURce<hw>]:BB:GNSS:SVID<ch>:NAVic:SDYNamics:PROFile.....	590
[SOURce<hw>]:BB:GNSS:SVID<ch>:QZSS:SDYNamics:PROFile.....	590
[SOURce<hw>]:BB:GNSS:SVID<ch>:BEIDou:SDYNamics:PROFile.....	590
[SOURce<hw>]:BB:GNSS:SVID<ch>:GLONass:SDYNamics:PROFile.....	590
[SOURce<hw>]:BB:GNSS:SVID<ch>:GALileo:SDYNamics:PROFile.....	590
[SOURce<hw>]:BB:GNSS:SVID<ch>:GPS:SDYNamics:PROFile.....	590
[SOURce<hw>]:BB:GNSS:SVID<ch>:SBAS:SDYNamics:CPHase.....	591
[SOURce<hw>]:BB:GNSS:SVID<ch>:NAVic:SDYNamics:CPHase.....	591
[SOURce<hw>]:BB:GNSS:SVID<ch>:QZSS:SDYNamics:CPHase.....	591
[SOURce<hw>]:BB:GNSS:SVID<ch>:BEIDou:SDYNamics:CPHase.....	591
[SOURce<hw>]:BB:GNSS:SVID<ch>:GLONass:SDYNamics:CPHase.....	591
[SOURce<hw>]:BB:GNSS:SVID<ch>:GALileo:SDYNamics:CPHase.....	591
[SOURce<hw>]:BB:GNSS:SVID<ch>:GPS:SDYNamics:CPHase.....	591
[SOURce<hw>]:BB:GNSS:SVID<ch>:SBAS:SDYNamics:PRANge.....	591
[SOURce<hw>]:BB:GNSS:SVID<ch>:NAVic:SDYNamics:PRANge.....	591
[SOURce<hw>]:BB:GNSS:SVID<ch>:QZSS:SDYNamics:PRANge.....	591
[SOURce<hw>]:BB:GNSS:SVID<ch>:BEIDou:SDYNamics:PRANge.....	591
[SOURce<hw>]:BB:GNSS:SVID<ch>:GLONass:SDYNamics:PRANge.....	591
[SOURce<hw>]:BB:GNSS:SVID<ch>:GALileo:SDYNamics:PRANge.....	591
[SOURce<hw>]:BB:GNSS:SVID<ch>:GPS:SDYNamics:PRANge.....	591
[SOURce<hw>]:BB:GNSS:SVID<ch>:SBAS:SDYNamics:VELocity.....	592
[SOURce<hw>]:BB:GNSS:SVID<ch>:NAVic:SDYNamics:VELocity.....	592
[SOURce<hw>]:BB:GNSS:SVID<ch>:QZSS:SDYNamics:VELocity.....	592
[SOURce<hw>]:BB:GNSS:SVID<ch>:BEIDou:SDYNamics:VELocity.....	592
[SOURce<hw>]:BB:GNSS:SVID<ch>:GLONass:SDYNamics:VELocity.....	592
[SOURce<hw>]:BB:GNSS:SVID<ch>:GALileo:SDYNamics:VELocity.....	592
[SOURce<hw>]:BB:GNSS:SVID<ch>:GPS:SDYNamics:VELocity.....	592
[SOURce<hw>]:BB:GNSS:SVID<ch>:SBAS:SDYNamics:TOFFset.....	592
[SOURce<hw>]:BB:GNSS:SVID<ch>:NAVic:SDYNamics:TOFFset.....	592
[SOURce<hw>]:BB:GNSS:SVID<ch>:QZSS:SDYNamics:TOFFset.....	592
[SOURce<hw>]:BB:GNSS:SVID<ch>:BEIDou:SDYNamics:TOFFset.....	592
[SOURce<hw>]:BB:GNSS:SVID<ch>:GLONass:SDYNamics:TOFFset.....	592
[SOURce<hw>]:BB:GNSS:SVID<ch>:GALileo:SDYNamics:TOFFset.....	592
[SOURce<hw>]:BB:GNSS:SVID<ch>:GPS:SDYNamics:TOFFset.....	592
[SOURce<hw>]:BB:GNSS:SVID<ch>:SBAS:SDYNamics:IVELocity.....	592
[SOURce<hw>]:BB:GNSS:SVID<ch>:NAVic:SDYNamics:IVELocity.....	592
[SOURce<hw>]:BB:GNSS:SVID<ch>:QZSS:SDYNamics:IVELocity.....	592
[SOURce<hw>]:BB:GNSS:SVID<ch>:BEIDou:SDYNamics:IVELocity.....	593

[SOURce<hw>]:BB:GNSS:SVID<ch>:GLONass:SDYNamics:IVELocity.....	593
[SOURce<hw>]:BB:GNSS:SVID<ch>:GALileo:SDYNamics:IVELocity.....	593
[SOURce<hw>]:BB:GNSS:SVID<ch>:GPS:SDYNamics:IVELocity.....	593
[SOURce<hw>]:BB:GNSS:SVID<ch>:SBAS:SDYNamics:CONFig.....	593
[SOURce<hw>]:BB:GNSS:SVID<ch>:NAVic:SDYNamics:CONFig.....	593
[SOURce<hw>]:BB:GNSS:SVID<ch>:QZSS:SDYNamics:CONFig.....	593
[SOURce<hw>]:BB:GNSS:SVID<ch>:BEIDou:SDYNamics:CONFig.....	593
[SOURce<hw>]:BB:GNSS:SVID<ch>:GLONass:SDYNamics:CONFig.....	593
[SOURce<hw>]:BB:GNSS:SVID<ch>:GALileo:SDYNamics:CONFig.....	593
[SOURce<hw>]:BB:GNSS:SVID<ch>:GPS:SDYNamics:CONFig.....	593
[SOURce<hw>]:BB:GNSS:SVID<ch>:SBAS:SDYNamics:CVPeriod.....	594
[SOURce<hw>]:BB:GNSS:SVID<ch>:NAVic:SDYNamics:CVPeriod.....	594
[SOURce<hw>]:BB:GNSS:SVID<ch>:QZSS:SDYNamics:CVPeriod.....	594
[SOURce<hw>]:BB:GNSS:SVID<ch>:BEIDou:SDYNamics:CVPeriod.....	594
[SOURce<hw>]:BB:GNSS:SVID<ch>:GLONass:SDYNamics:CVPeriod.....	594
[SOURce<hw>]:BB:GNSS:SVID<ch>:GALileo:SDYNamics:CVPeriod.....	594
[SOURce<hw>]:BB:GNSS:SVID<ch>:GPS:SDYNamics:CVPeriod.....	594
[SOURce<hw>]:BB:GNSS:SVID<ch>:SBAS:SDYNamics:CAPeriod.....	594
[SOURce<hw>]:BB:GNSS:SVID<ch>:NAVic:SDYNamics:CAPeriod.....	594
[SOURce<hw>]:BB:GNSS:SVID<ch>:QZSS:SDYNamics:CAPeriod.....	594
[SOURce<hw>]:BB:GNSS:SVID<ch>:BEIDou:SDYNamics:CAPeriod.....	594
[SOURce<hw>]:BB:GNSS:SVID<ch>:GLONass:SDYNamics:CAPeriod.....	594
[SOURce<hw>]:BB:GNSS:SVID<ch>:GALileo:SDYNamics:CAPeriod.....	594
[SOURce<hw>]:BB:GNSS:SVID<ch>:GPS:SDYNamics:CAPeriod.....	594
[SOURce<hw>]:BB:GNSS:SVID<ch>:SBAS:SDYNamics:ACCel:MAX.....	595
[SOURce<hw>]:BB:GNSS:SVID<ch>:NAVic:SDYNamics:ACCel:MAX.....	595
[SOURce<hw>]:BB:GNSS:SVID<ch>:QZSS:SDYNamics:ACCel:MAX.....	595
[SOURce<hw>]:BB:GNSS:SVID<ch>:BEIDou:SDYNamics:ACCel:MAX.....	595
[SOURce<hw>]:BB:GNSS:SVID<ch>:GLONass:SDYNamics:ACCel:MAX.....	595
[SOURce<hw>]:BB:GNSS:SVID<ch>:GALileo:SDYNamics:ACCel:MAX.....	595
[SOURce<hw>]:BB:GNSS:SVID<ch>:GPS:SDYNamics:ACCel:MAX.....	595
[SOURce<hw>]:BB:GNSS:SVID<ch>:SBAS:SDYNamics:JERK:MAX.....	595
[SOURce<hw>]:BB:GNSS:SVID<ch>:NAVic:SDYNamics:JERK:MAX.....	595
[SOURce<hw>]:BB:GNSS:SVID<ch>:QZSS:SDYNamics:JERK:MAX.....	595
[SOURce<hw>]:BB:GNSS:SVID<ch>:BEIDou:SDYNamics:JERK:MAX.....	595
[SOURce<hw>]:BB:GNSS:SVID<ch>:GLONass:SDYNamics:JERK:MAX.....	595
[SOURce<hw>]:BB:GNSS:SVID<ch>:GALileo:SDYNamics:JERK:MAX.....	595
[SOURce<hw>]:BB:GNSS:SVID<ch>:GPS:SDYNamics:JERK:MAX.....	595
[SOURce<hw>]:BB:GNSS:SVID<ch>:SBAS:SDYNamics:RPERiod?.....	596
[SOURce<hw>]:BB:GNSS:SVID<ch>:NAVic:SDYNamics:RPERiod?.....	596
[SOURce<hw>]:BB:GNSS:SVID<ch>:QZSS:SDYNamics:RPERiod?.....	596
[SOURce<hw>]:BB:GNSS:SVID<ch>:BEIDou:SDYNamics:RPERiod?.....	596
[SOURce<hw>]:BB:GNSS:SVID<ch>:GLONass:SDYNamics:RPERiod?.....	596
[SOURce<hw>]:BB:GNSS:SVID<ch>:GALileo:SDYNamics:RPERiod?.....	596
[SOURce<hw>]:BB:GNSS:SVID<ch>:GPS:SDYNamics:RPERiod?.....	596

```

[:SOURce<hw>]:BB:GNSS:SVID<ch>:SBAS:SIGNal:L5Band:EL5S:DATA:
    NMESsage[:STATe] <State>
[:SOURce<hw>]:BB:GNSS:SVID<ch>:SBAS:SIGNal:L1Band:CA:DATA:
    NMESsage[:STATe] <State>
[:SOURce<hw>]:BB:GNSS:SVID<ch>:NAVic:SIGNal:L5Band:SPS:DATA:
    NMESsage[:STATe] <State>
[:SOURce<hw>]:BB:GNSS:SVID<ch>:QZSS:SIGNal:L5Band:L5S:DATA:
    NMESsage[:STATe] <State>
[:SOURce<hw>]:BB:GNSS:SVID<ch>:QZSS:SIGNal:L2Band:L2C:DATA:
    NMESsage[:STATe] <State>
[:SOURce<hw>]:BB:GNSS:SVID<ch>:QZSS:SIGNal:L1Band:CA:DATA:
    NMESsage[:STATe] <State>
[:SOURce<hw>]:BB:GNSS:SVID<ch>:QZSS:SIGNal:L1Band:L1C:DATA:
    NMESsage[:STATe] <State>
[:SOURce<hw>]:BB:GNSS:SVID<ch>:BEIDou:SIGNal:L5Band:B2A:DATA:
    NMESsage[:STATe] <State>
[:SOURce<hw>]:BB:GNSS:SVID<ch>:BEIDou:SIGNal:L5Band:B2B:DATA:
    NMESsage[:STATe] <State>
[:SOURce<hw>]:BB:GNSS:SVID<ch>:BEIDou:SIGNal:L5Band:B2I:DATA:
    NMESsage[:STATe] <State>
[:SOURce<hw>]:BB:GNSS:SVID<ch>:BEIDou:SIGNal:L2Band:B3I:DATA:
    NMESsage[:STATe] <State>
[:SOURce<hw>]:BB:GNSS:SVID<ch>:BEIDou:SIGNal:L1Band:B1C:DATA:
    NMESsage[:STATe] <State>
[:SOURce<hw>]:BB:GNSS:SVID<ch>:BEIDou:SIGNal:L1Band:B1I:DATA:
    NMESsage[:STATe] <State>
[:SOURce<hw>]:BB:GNSS:SVID<ch>:GLONass:SIGNal:L5Band:L3CDma:DATA:
    NMESsage[:STATe] <State>
[:SOURce<hw>]:BB:GNSS:SVID<ch>:GLONass:SIGNal:L2Band:CA:DATA:
    NMESsage[:STATe] <State>
[:SOURce<hw>]:BB:GNSS:SVID<ch>:GLONass:SIGNal:L2Band:L2CDma:DATA:
    NMESsage[:STATe] <State>
[:SOURce<hw>]:BB:GNSS:SVID<ch>:GLONass:SIGNal:L1Band:CA:DATA:
    NMESsage[:STATe] <State>
[:SOURce<hw>]:BB:GNSS:SVID<ch>:GLONass:SIGNal:L1Band:L1CDma:DATA:
    NMESsage[:STATe] <State>
[:SOURce<hw>]:BB:GNSS:SVID<ch>:GALileo:SIGNal:L5Band:E5A:DATA:
    NMESsage[:STATe] <State>
[:SOURce<hw>]:BB:GNSS:SVID<ch>:GALileo:SIGNal:L5Band:E5B:DATA:
    NMESsage[:STATe] <State>
[:SOURce<hw>]:BB:GNSS:SVID<ch>:GALileo:SIGNal:L2Band:E6PRs:DATA:
    NMESsage[:STATe] <State>
[:SOURce<hw>]:BB:GNSS:SVID<ch>:GALileo:SIGNal:L2Band:E6S:DATA:
    NMESsage[:STATe] <State>
[:SOURce<hw>]:BB:GNSS:SVID<ch>:GALileo:SIGNal:L1Band:E1OS:DATA:
    NMESsage[:STATe] <State>
[:SOURce<hw>]:BB:GNSS:SVID<ch>:GALileo:SIGNal:L1Band:E1PRs:DATA:
    NMESsage[:STATe] <State>

```

```

[:SOURce<hw>]:BB:GNSS:SVID<ch>:GPS:SIGNal:L5Band:L5S:DATA:
  NMEssage[:STATe] <State>
[:SOURce<hw>]:BB:GNSS:SVID<ch>:GPS:SIGNal:L2Band:CA:DATA:NMEssage[:
  STATe] <State>
[:SOURce<hw>]:BB:GNSS:SVID<ch>:GPS:SIGNal:L2Band:L2C:DATA:
  NMEssage[:STATe] <State>
[:SOURce<hw>]:BB:GNSS:SVID<ch>:GPS:SIGNal:L2Band:M:DATA:NMEssage[:
  STATe] <State>
[:SOURce<hw>]:BB:GNSS:SVID<ch>:GPS:SIGNal:L2Band:P:DATA:NMEssage[:
  STATe] <State>
[:SOURce<hw>]:BB:GNSS:SVID<ch>:GPS:SIGNal:L2Band:PY:DATA:NMEssage[:
  STATe] <State>
[:SOURce<hw>]:BB:GNSS:SVID<ch>:GPS:SIGNal:L1Band:L1C:DATA:
  NMEssage[:STATe] <State>
[:SOURce<hw>]:BB:GNSS:SVID<ch>:GPS:SIGNal:L1Band:M:DATA:NMEssage[:
  STATe] <State>
[:SOURce<hw>]:BB:GNSS:SVID<ch>:GPS:SIGNal:L1Band:P:DATA:NMEssage[:
  STATe] <State>
[:SOURce<hw>]:BB:GNSS:SVID<ch>:GPS:SIGNal:L1Band:PY:DATA:NMEssage[:
  STATe] <State>
[:SOURce<hw>]:BB:GNSS:SVID<ch>:GPS:SIGNal:L1Band:CA:DATA:NMEssage[:
  STATe] <State>

```

In tracking mode, enables configuration of the navigation message parameters.

Parameters:

<State> 1 | ON | 0 | OFF
 *RST: 1

Example: See [Example "Configuring the signal dynamics"](#) on page 585.

Manual operation: See ["Nav Msg"](#) on page 91

```

[:SOURce<hw>]:BB:GNSS:SVID<ch>:SBAS:SDYNAmics:PROFile <Profile>
[:SOURce<hw>]:BB:GNSS:SVID<ch>:NAVic:SDYNAmics:PROFile <Profile>
[:SOURce<hw>]:BB:GNSS:SVID<ch>:QZSS:SDYNAmics:PROFile <Profile>
[:SOURce<hw>]:BB:GNSS:SVID<ch>:BEIDou:SDYNAmics:PROFile <Profile>
[:SOURce<hw>]:BB:GNSS:SVID<ch>:GLONass:SDYNAmics:PROFile <Profile>
[:SOURce<hw>]:BB:GNSS:SVID<ch>:GALileo:SDYNAmics:PROFile <Profile>
[:SOURce<hw>]:BB:GNSS:SVID<ch>:GPS:SDYNAmics:PROFile <Profile>

```

Selects the dynamics profile type.

Parameters:

<Profile> CONStant | HIGH
CONStant
 Constant velocity as set with the command `[:SOURce<hw>]:BB:GNSS:SVID<ch>:GPS:SDYNAmics:VELOCITY`.

HIGH

Profiles with higher-order dynamics as set with the command [:
[SOURce<hw>](#)] : BB : GNSS : SVID <ch> : GPS : SDYNamics :
 CONFig.

*RST: CONStant

Example: See [Example"Configuring the signal dynamics"](#) on page 585.

Manual operation: See ["Mode"](#) on page 182

```
[ :SOURce<hw>]:BB:GNSS:SVID<ch>:SBAS:SDYNamics:CPHase <CPhase>
[ :SOURce<hw>]:BB:GNSS:SVID<ch>:NAVic:SDYNamics:CPHase <CPhase>
[ :SOURce<hw>]:BB:GNSS:SVID<ch>:QZSS:SDYNamics:CPHase <CPhase>
[ :SOURce<hw>]:BB:GNSS:SVID<ch>:BEIDou:SDYNamics:CPHase <CPhase>
[ :SOURce<hw>]:BB:GNSS:SVID<ch>:GLONass:SDYNamics:CPHase <CPhase>
[ :SOURce<hw>]:BB:GNSS:SVID<ch>:GALileo:SDYNamics:CPHase <CPhase>
[ :SOURce<hw>]:BB:GNSS:SVID<ch>:GPS:SDYNamics:CPHase <CPhase>
```

Sets the initial carrier phase.

Parameters:

```
<CPhase>            float
                    Range:     0 to 6.28
                    Increment: 0.01
                    *RST:     0
```

Example: See [Example"Configuring the signal dynamics"](#) on page 585.

Manual operation: See ["Inital Carrier Phase \(L1\)"](#) on page 183

```
[ :SOURce<hw>]:BB:GNSS:SVID<ch>:SBAS:SDYNamics:PRANge <PRange>
[ :SOURce<hw>]:BB:GNSS:SVID<ch>:NAVic:SDYNamics:PRANge <PRange>
[ :SOURce<hw>]:BB:GNSS:SVID<ch>:QZSS:SDYNamics:PRANge <PRange>
[ :SOURce<hw>]:BB:GNSS:SVID<ch>:BEIDou:SDYNamics:PRANge <PRange>
[ :SOURce<hw>]:BB:GNSS:SVID<ch>:GLONass:SDYNamics:PRANge <PRange>
[ :SOURce<hw>]:BB:GNSS:SVID<ch>:GALileo:SDYNamics:PRANge <PRange>
[ :SOURce<hw>]:BB:GNSS:SVID<ch>:GPS:SDYNamics:PRANge <PRange>
```

Sets the initial pseudorange.

Parameters:

```
<PRange>            float
                    Range:     0 to 119900000
                    Increment: 0.001
                    *RST:     0
```

Example: See [Example"Configuring the signal dynamics"](#) on page 585.

Manual operation: See ["Inital Pseudorange"](#) on page 182

```
[:SOURce<hw>]:BB:GNSS:SVID<ch>:SBAS:SDYNamics:VELocity <Velocity>
[:SOURce<hw>]:BB:GNSS:SVID<ch>:NAVic:SDYNamics:VELocity <Velocity>
[:SOURce<hw>]:BB:GNSS:SVID<ch>:QZSS:SDYNamics:VELocity <Velocity>
[:SOURce<hw>]:BB:GNSS:SVID<ch>:BEIDou:SDYNamics:VELocity <Velocity>
[:SOURce<hw>]:BB:GNSS:SVID<ch>:GLONass:SDYNamics:VELocity <Velocity>
[:SOURce<hw>]:BB:GNSS:SVID<ch>:GALileo:SDYNamics:VELocity <Velocity>
[:SOURce<hw>]:BB:GNSS:SVID<ch>:GPS:SDYNamics:VELocity <Velocity>
```

Sets the satellite velocity for constant velocity profile.

The velocity ranges depend on the GNSS and related space vehicles.

Parameters:

<Velocity>	float	
Range:	depends on settings	to depends on settings
Increment:	1E-4	
*RST:	0	

Example:

```
:SOURce1:BB:GNSS:SVID1:GPS:SDYNamics:PROFile Constant
:SOURce1:BB:GNSS:SVID1:GPS:SDYNamics:VELocity 100
// Sets a velocity of 100 m/s.
```

Manual operation: See "[Velocity \(Pseudorange Rate\)](#)" on page 183

```
[:SOURce<hw>]:BB:GNSS:SVID<ch>:SBAS:SDYNamics:TOFFset <TimeOffset>
[:SOURce<hw>]:BB:GNSS:SVID<ch>:NAVic:SDYNamics:TOFFset <TimeOffset>
[:SOURce<hw>]:BB:GNSS:SVID<ch>:QZSS:SDYNamics:TOFFset <TimeOffset>
[:SOURce<hw>]:BB:GNSS:SVID<ch>:BEIDou:SDYNamics:TOFFset <TimeOffset>
[:SOURce<hw>]:BB:GNSS:SVID<ch>:GLONass:SDYNamics:TOFFset
<TimeOffset>
[:SOURce<hw>]:BB:GNSS:SVID<ch>:GALileo:SDYNamics:TOFFset <TimeOffset>
[:SOURce<hw>]:BB:GNSS:SVID<ch>:GPS:SDYNamics:TOFFset <TimeOffset>
```

Sets a time delay before the profile is applied.

Parameters:

<TimeOffset>	float
Range:	0 to 9E4
Increment:	0.1
*RST:	0

Example: See [Example"Configuring the signal dynamics"](#) on page 585.

Manual operation: See "[Start Time Offset](#)" on page 183

```
[:SOURce<hw>]:BB:GNSS:SVID<ch>:SBAS:SDYNamics:IVELocity
<InitialVelocity>
[:SOURce<hw>]:BB:GNSS:SVID<ch>:NAVic:SDYNamics:IVELocity
<InitialVelocity>
[:SOURce<hw>]:BB:GNSS:SVID<ch>:QZSS:SDYNamics:IVELocity
<InitialVelocity>
```



```
[:SOURce<hw>]:BB:GNSS:SVID<ch>:BEIDou:SDYNamics:IVeLocity
<InitialVelocity>
[:SOURce<hw>]:BB:GNSS:SVID<ch>:GLONass:SDYNamics:IVeLocity
<InitialVelocity>
[:SOURce<hw>]:BB:GNSS:SVID<ch>:GALileo:SDYNamics:IVeLocity
<InitialVelocity>
[:SOURce<hw>]:BB:GNSS:SVID<ch>:GPS:SDYNamics:IVeLocity <InitialVelocity>
```

Indicates the initial velocity, used at the beginning of the profile.

Parameters:

```
<InitialVelocity> float
Range: -19042 to 19042
Increment: 1E-4
*RST: 3.62
```

Example: See [Example"Configuring the signal dynamics"](#) on page 585.

Manual operation: See ["Initial Velocity \(Pseudorange Rate\)"](#) on page 184

```
[:SOURce<hw>]:BB:GNSS:SVID<ch>:SBAS:SDYNamics:CONFig
<PredefinedConfi>
[:SOURce<hw>]:BB:GNSS:SVID<ch>:NAVic:SDYNamics:CONFig
<PredefinedConfi>
[:SOURce<hw>]:BB:GNSS:SVID<ch>:QZSS:SDYNamics:CONFig
<PredefinedConfi>
[:SOURce<hw>]:BB:GNSS:SVID<ch>:BEIDou:SDYNamics:CONFig
<PredefinedConfi>
[:SOURce<hw>]:BB:GNSS:SVID<ch>:GLONass:SDYNamics:CONFig
<PredefinedConfi>
[:SOURce<hw>]:BB:GNSS:SVID<ch>:GALileo:SDYNamics:CONFig
<PredefinedConfi>
[:SOURce<hw>]:BB:GNSS:SVID<ch>:GPS:SDYNamics:CONFig
<PredefinedConfi>
```

Selects between the predefined velocity profiles or a user-defined one.

Parameters:

```
<PredefinedConfi> USER | VEL1 | VEL2

USER
User-defined
Profile parametrs are configurable.

VEL1
Low dynamics
Profile parametrs are read-only.

VEL2
High dynamics
Profile parametrs are read-only.

*RST: VEL1
```

Example: See [Example"Configuring the signal dynamics"](#) on page 585.

Manual operation: See ["Velocity Profile"](#) on page 183

```
[:SOURce<hw>]:BB:GNSS:SVID<ch>:SBAS:SDYnAmics:CVPeriod
<ConstVelPeriod>
[:SOURce<hw>]:BB:GNSS:SVID<ch>:NAVic:SDYnAmics:CVPeriod
<ConstVelPeriod>
[:SOURce<hw>]:BB:GNSS:SVID<ch>:QZSS:SDYnAmics:CVPeriod
<ConstVelPeriod>
[:SOURce<hw>]:BB:GNSS:SVID<ch>:BEIDou:SDYnAmics:CVPeriod
<ConstVelPeriod>
[:SOURce<hw>]:BB:GNSS:SVID<ch>:GLONass:SDYnAmics:CVPeriod
<ConstVelPeriod>
[:SOURce<hw>]:BB:GNSS:SVID<ch>:GALileo:SDYnAmics:CVPeriod
<ConstVelPeriod>
[:SOURce<hw>]:BB:GNSS:SVID<ch>:GPS:SDYnAmics:CVPeriod
<ConstVelPeriod>
```

Sets the time period during that the velocity is kept constant.

Parameters:

```
<ConstVelPeriod> float
Range: 0.1 to 10800
Increment: 0.1
*RST: 5
```

Example: See [Example"Configuring the signal dynamics"](#) on page 585.

Manual operation: See ["Constant Velocity Period"](#) on page 184

```
[:SOURce<hw>]:BB:GNSS:SVID<ch>:SBAS:SDYnAmics:CAPeriod
<ConstAccPeriod>
[:SOURce<hw>]:BB:GNSS:SVID<ch>:NAVic:SDYnAmics:CAPeriod
<ConstAccPeriod>
[:SOURce<hw>]:BB:GNSS:SVID<ch>:QZSS:SDYnAmics:CAPeriod
<ConstAccPeriod>
[:SOURce<hw>]:BB:GNSS:SVID<ch>:BEIDou:SDYnAmics:CAPeriod
<ConstAccPeriod>
[:SOURce<hw>]:BB:GNSS:SVID<ch>:GLONass:SDYnAmics:CAPeriod
<ConstAccPeriod>
[:SOURce<hw>]:BB:GNSS:SVID<ch>:GALileo:SDYnAmics:CAPeriod
<ConstAccPeriod>
[:SOURce<hw>]:BB:GNSS:SVID<ch>:GPS:SDYnAmics:CAPeriod
<ConstAccPeriod>
```

Sets the time duration during that acceleration is applied and thus the velocity varies.

Parameters:

```
<ConstAccPeriod> float
Range: 0.1 to 10800
Increment: 0.1
*RST: 45
```

Example: See [Example"Configuring the signal dynamics"](#) on page 585.

Manual operation: See ["Constant Acceleration Period"](#) on page 184

```
[:SOURce<hw>]:BB:GNSS:SVID<ch>:SBAS:SDYnAmics:ACCel:MAX
<MaxAcceleration>
[:SOURce<hw>]:BB:GNSS:SVID<ch>:NAVic:SDYnAmics:ACCel:MAX
<MaxAcceleration>
[:SOURce<hw>]:BB:GNSS:SVID<ch>:QZSS:SDYnAmics:ACCel:MAX
<MaxAcceleration>
[:SOURce<hw>]:BB:GNSS:SVID<ch>:BEIDou:SDYnAmics:ACCel:MAX
<MaxAcceleration>
[:SOURce<hw>]:BB:GNSS:SVID<ch>:GLONass:SDYnAmics:ACCel:MAX
<MaxAcceleration>
[:SOURce<hw>]:BB:GNSS:SVID<ch>:GALileo:SDYnAmics:ACCel:MAX
<MaxAcceleration>
[:SOURce<hw>]:BB:GNSS:SVID<ch>:GPS:SDYnAmics:ACCel:MAX
<MaxAcceleration>
```

Sets the maximum acceleration.

Parameters:

```
<MaxAcceleration> float
Range: 0.01 to 1000
Increment: 0.0001
*RST: 0.7612
```

Example: See [Example"Configuring the signal dynamics"](#) on page 585.

Manual operation: See ["Maximum Acceleration"](#) on page 184

```
[:SOURce<hw>]:BB:GNSS:SVID<ch>:SBAS:SDYnAmics:JERK:MAX <MaxJerk>
[:SOURce<hw>]:BB:GNSS:SVID<ch>:NAVic:SDYnAmics:JERK:MAX <MaxJerk>
[:SOURce<hw>]:BB:GNSS:SVID<ch>:QZSS:SDYnAmics:JERK:MAX <MaxJerk>
[:SOURce<hw>]:BB:GNSS:SVID<ch>:BEIDou:SDYnAmics:JERK:MAX <MaxJerk>
[:SOURce<hw>]:BB:GNSS:SVID<ch>:GLONass:SDYnAmics:JERK:MAX
<MaxJerk>
[:SOURce<hw>]:BB:GNSS:SVID<ch>:GALileo:SDYnAmics:JERK:MAX <MaxJerk>
[:SOURce<hw>]:BB:GNSS:SVID<ch>:GPS:SDYnAmics:JERK:MAX <MaxJerk>
```

Sets the maximum jerk.

Parameters:

```
<MaxJerk> float
Range: 0.1 to 7E4
Increment: 0.0001
*RST: 19.0295
```

Example: See [Example"Configuring the signal dynamics"](#) on page 585.

Manual operation: See ["Maximum Jerk"](#) on page 184

```
[:SOURce<hw>]:BB:GNSS:SVID<ch>:SBAS:SDYnAmics:RPERiod?
[:SOURce<hw>]:BB:GNSS:SVID<ch>:NAVic:SDYnAmics:RPERiod?
[:SOURce<hw>]:BB:GNSS:SVID<ch>:QZSS:SDYnAmics:RPERiod?
[:SOURce<hw>]:BB:GNSS:SVID<ch>:BEIDou:SDYnAmics:RPERiod?
[:SOURce<hw>]:BB:GNSS:SVID<ch>:GLONass:SDYnAmics:RPERiod?
[:SOURce<hw>]:BB:GNSS:SVID<ch>:GALileo:SDYnAmics:RPERiod?
[:SOURce<hw>]:BB:GNSS:SVID<ch>:GPS:SDYnAmics:RPERiod?
```

Queries the duration of the profile.

Return values:

```
<RepetitionPer>    float
                   Range:    0 to 9E4
                   Increment: 0.1
                   *RST:     0
```

Example: See [Example "Configuring the signal dynamics"](#) on page 585.

Usage: Query only

Manual operation: See ["Repetition Period"](#) on page 184

22.17 Assistance data commands

Assistance data commands for a GNSS require installation of this basic GNSS system option, see [Table 2-1](#).

Example: Generating GPS assistance data

```
SOURce1:BB:GNSS:PRESet
SOURce1:BB:GNSS:TMODe NAV
SOURce1:BB:GNSS:ADGeneration:MODE GPS
SOURce1:BB:GNSS:ADGeneration:GPS:SYNChronize
SOURce1:BB:GNSS:ADGeneration:NAVigation:DFORmat LNAV
SOURce1:BB:GNSS:ADGeneration:GPS:SVID11:STATe?
// Response: 1

SOURce1:BB:GNSS:ADGeneration:GPS:TOAData:TBASis?
// Response: "UTC"
SOURce1:BB:GNSS:ADGeneration:GPS:TOAData:DATE?
// Response: "1752,9,14"
SOURce1:BB:GNSS:ADGeneration:GPS:TOAData:TIME?
// Response: "6,0,0"
SOURce1:BB:GNSS:ADGeneration:GPS:TOAData:TBASis?
// Response: "GPS"
SOURce1:BB:GNSS:ADGeneration:GPS:TOAData:WNUmber?
// Response: "-11860"
SOURce1:BB:GNSS:ADGeneration:GPS:TOAData:TOWeek?
// Response: "-237584"
SOURce1:BB:GNSS:ADGeneration:GPS:TOAData:DURation 1140.08
SOURce1:BB:GNSS:ADGeneration:GPS:TOAData:RESolution 0.08
```

```
SOURcel:BB:GNSS:ADGeneration:ALManac:CREate "/var/user/ADG/almanac.rs_al"
SOURcel:BB:GNSS:ADGeneration:ALManac:CREate "/var/user/ADG/almanac.rs_yuma"
SOURcel:BB:GNSS:ADGeneration:NAVigation:CREate '/var/user/ADG/navigation'
SOURcel:BB:GNSS:ADGeneration:NAVigation:CREate '/var/user/ADG/RINEX.110n'
SOURcel:BB:GNSS:ADGeneration:ACQ:CREate '/var/user/ADG/acquisition'
MME:CAT? '/var/user/ADG'
// Response: 25301,43275001856,".,DIR,0",".,DIR,0","acquisition.rs_acq,BIN,525",
// "almanac.rs_al,BIN,5518","almanac.rs_yuma,BIN,18344","ion.rs_ion,BIN,70",
// "navigation.rs_nav,BIN,245","RINEX.110n,BIN,525","UTC.rs_utc,BIN,74"
```

Commands:

[SOURce<hw>]:BB:GNSS:ADGeneration:NAVIC:SYNChronize.....	598
[SOURce<hw>]:BB:GNSS:ADGeneration:QZSS:SYNChronize.....	598
[SOURce<hw>]:BB:GNSS:ADGeneration:BEIDou:SYNChronize.....	598
[SOURce<hw>]:BB:GNSS:ADGeneration:GLONass:SYNChronize.....	598
[SOURce<hw>]:BB:GNSS:ADGeneration:GALileo:SYNChronize.....	598
[SOURce<hw>]:BB:GNSS:ADGeneration:GPS:SYNChronize.....	598
[SOURce<hw>]:BB:GNSS:ADGeneration:MODE.....	598
[SOURce<hw>]:BB:GNSS:ADGeneration:NAVigation:DFORmat.....	599
[SOURce<hw>]:BB:GNSS:ADGeneration:NAVIC:SVID<ch>:STATe.....	599
[SOURce<hw>]:BB:GNSS:ADGeneration:QZSS:SVID<ch>:STATe.....	599
[SOURce<hw>]:BB:GNSS:ADGeneration:BEIDou:SVID<ch>:STATe.....	599
[SOURce<hw>]:BB:GNSS:ADGeneration:GLONass:SVID<ch>:STATe.....	599
[SOURce<hw>]:BB:GNSS:ADGeneration:GALileo:SVID<ch>:STATe.....	599
[SOURce<hw>]:BB:GNSS:ADGeneration:GPS:SVID<ch>:STATe.....	599
[SOURce<hw>]:BB:GNSS:ADGeneration:NAVIC:TOAData:TBASis?.....	599
[SOURce<hw>]:BB:GNSS:ADGeneration:QZSS:TOAData:TBASis?.....	599
[SOURce<hw>]:BB:GNSS:ADGeneration:BEIDou:TOAData:TBASis?.....	599
[SOURce<hw>]:BB:GNSS:ADGeneration:GLONass:TOAData:TBASis?.....	599
[SOURce<hw>]:BB:GNSS:ADGeneration:GALileo:TOAData:TBASis?.....	599
[SOURce<hw>]:BB:GNSS:ADGeneration:GPS:TOAData:TBASis?.....	599
[SOURce<hw>]:BB:GNSS:ADGeneration:NAVIC:TOAData:DATE?.....	599
[SOURce<hw>]:BB:GNSS:ADGeneration:QZSS:TOAData:DATE?.....	599
[SOURce<hw>]:BB:GNSS:ADGeneration:BEIDou:TOAData:DATE?.....	599
[SOURce<hw>]:BB:GNSS:ADGeneration:GLONass:TOAData:DATE?.....	599
[SOURce<hw>]:BB:GNSS:ADGeneration:GALileo:TOAData:DATE?.....	600
[SOURce<hw>]:BB:GNSS:ADGeneration:GPS:TOAData:DATE?.....	600
[SOURce<hw>]:BB:GNSS:ADGeneration:NAVIC:TOAData:TIME?.....	600
[SOURce<hw>]:BB:GNSS:ADGeneration:QZSS:TOAData:TIME?.....	600
[SOURce<hw>]:BB:GNSS:ADGeneration:BEIDou:TOAData:TIME?.....	600
[SOURce<hw>]:BB:GNSS:ADGeneration:GLONass:TOAData:TIME?.....	600
[SOURce<hw>]:BB:GNSS:ADGeneration:GALileo:TOAData:TIME?.....	600
[SOURce<hw>]:BB:GNSS:ADGeneration:GPS:TOAData:TIME?.....	600
[SOURce<hw>]:BB:GNSS:ADGeneration:NAVIC:TOAData:DURation.....	601
[SOURce<hw>]:BB:GNSS:ADGeneration:QZSS:TOAData:DURation.....	601
[SOURce<hw>]:BB:GNSS:ADGeneration:BEIDou:TOAData:DURation.....	601
[SOURce<hw>]:BB:GNSS:ADGeneration:GLONass:TOAData:DURation.....	601
[SOURce<hw>]:BB:GNSS:ADGeneration:GALileo:TOAData:DURation.....	601
[SOURce<hw>]:BB:GNSS:ADGeneration:GPS:TOAData:DURation.....	601

<code>[:SOURce<hw>]:BB:GNSS:ADGeneration:NAVIC:TOAData:RESolution</code>	601
<code>[:SOURce<hw>]:BB:GNSS:ADGeneration:QZSS:TOAData:RESolution</code>	601
<code>[:SOURce<hw>]:BB:GNSS:ADGeneration:BEIDou:TOAData:RESolution</code>	601
<code>[:SOURce<hw>]:BB:GNSS:ADGeneration:GLONass:TOAData:RESolution</code>	601
<code>[:SOURce<hw>]:BB:GNSS:ADGeneration:GALileo:TOAData:RESolution</code>	601
<code>[:SOURce<hw>]:BB:GNSS:ADGeneration:GPS:TOAData:RESolution</code>	601
<code>[:SOURce<hw>]:BB:GNSS:ADGeneration:NAVIC:TOAData:TOWeek?</code>	601
<code>[:SOURce<hw>]:BB:GNSS:ADGeneration:QZSS:TOAData:TOWeek?</code>	601
<code>[:SOURce<hw>]:BB:GNSS:ADGeneration:BEIDou:TOAData:TOWeek?</code>	601
<code>[:SOURce<hw>]:BB:GNSS:ADGeneration:GLONass:TOAData:TOWeek?</code>	601
<code>[:SOURce<hw>]:BB:GNSS:ADGeneration:GALileo:TOAData:TOWeek?</code>	602
<code>[:SOURce<hw>]:BB:GNSS:ADGeneration:GPS:TOAData:TOWeek?</code>	602
<code>[:SOURce<hw>]:BB:GNSS:ADGeneration:NAVIC:TOAData:WNUmber?</code>	602
<code>[:SOURce<hw>]:BB:GNSS:ADGeneration:QZSS:TOAData:WNUmber?</code>	602
<code>[:SOURce<hw>]:BB:GNSS:ADGeneration:BEIDou:TOAData:WNUmber?</code>	602
<code>[:SOURce<hw>]:BB:GNSS:ADGeneration:GLONass:TOAData:WNUmber?</code>	602
<code>[:SOURce<hw>]:BB:GNSS:ADGeneration:GALileo:TOAData:WNUmber?</code>	602
<code>[:SOURce<hw>]:BB:GNSS:ADGeneration:GPS:TOAData:WNUmber?</code>	602
<code>[:SOURce<hw>]:BB:GNSS:ADGeneration:ACQuisition:CREate</code>	602
<code>[:SOURce<hw>]:BB:GNSS:ADGeneration:ALManac:CREate</code>	603
<code>[:SOURce<hw>]:BB:GNSS:ADGeneration:NAVigation:CREate</code>	603

`[:SOURce<hw>]:BB:GNSS:ADGeneration:NAVIC:SYNChronize`
`[:SOURce<hw>]:BB:GNSS:ADGeneration:QZSS:SYNChronize`
`[:SOURce<hw>]:BB:GNSS:ADGeneration:BEIDou:SYNChronize`
`[:SOURce<hw>]:BB:GNSS:ADGeneration:GLONass:SYNChronize`
`[:SOURce<hw>]:BB:GNSS:ADGeneration:GALileo:SYNChronize`
`[:SOURce<hw>]:BB:GNSS:ADGeneration:GPS:SYNChronize`

Synchronizes the affected parameters.

Example: See [Example "Generating GPS assistance data"](#) on page 596.

Usage: Event

Manual operation: See ["Synchronize SVs"](#) on page 302

`[:SOURce<hw>]:BB:GNSS:ADGeneration:MODE <Mode>`

Defines the type of assistance data to be loaded.

Parameters:

<Mode> GPS | GALileo | GLONass | NAVic | QZSS | SBAS | BEIDou
 *RST: GPS

Example: See [Example "Generating GPS assistance data"](#) on page 596

Options: R&S SMW-K44/K66/K94/K97/K106/K107

Manual operation: See ["Assistance Mode"](#) on page 301

```
[ :SOURce<hw>]:BB:GNSS:ADGeneration:NAVigation:DFORmat <DataFormat>
```

Sets format of the generated navigation data file.

Parameters:

```
<DataFormat>      LNAV | CNAV
                  *RST:      LNAV
```

Example: See [Example "Generating GPS assistance data"](#) on page 596.

Manual operation: See ["Navigation Data Format"](#) on page 302

```
[ :SOURce<hw>]:BB:GNSS:ADGeneration:NAVIC:SVID<ch>:STATe <State>
[ :SOURce<hw>]:BB:GNSS:ADGeneration:QZSS:SVID<ch>:STATe <State>
[ :SOURce<hw>]:BB:GNSS:ADGeneration:BEIDou:SVID<ch>:STATe <State>
[ :SOURce<hw>]:BB:GNSS:ADGeneration:GLONass:SVID<ch>:STATe <State>
[ :SOURce<hw>]:BB:GNSS:ADGeneration:GALileo:SVID<ch>:STATe <State>
[ :SOURce<hw>]:BB:GNSS:ADGeneration:GPS:SVID<ch>:STATe <State>
```

Activates satellites so that they are included in the generated assistance data.

Parameters:

```
<State>           1 | ON | 0 | OFF
                  *RST:      0
```

Example: See [Example "Generating GPS assistance data"](#) on page 596.

Manual operation: See ["Space Vehicles"](#) on page 305

```
[ :SOURce<hw>]:BB:GNSS:ADGeneration:NAVIC:TOAData:TBASis?
[ :SOURce<hw>]:BB:GNSS:ADGeneration:QZSS:TOAData:TBASis?
[ :SOURce<hw>]:BB:GNSS:ADGeneration:BEIDou:TOAData:TBASis?
[ :SOURce<hw>]:BB:GNSS:ADGeneration:GLONass:TOAData:TBASis?
[ :SOURce<hw>]:BB:GNSS:ADGeneration:GALileo:TOAData:TBASis?
[ :SOURce<hw>]:BB:GNSS:ADGeneration:GPS:TOAData:TBASis?
```

Queries the timebase for the time of assistance data parameters.

Return values:

```
<TimeBasis>      UTC | GPS | GST | GLO | BDT | NAV
                  *RST:      UTC
```

Example: See [Example "Generating GPS assistance data"](#) on page 596.

Usage: Query only

Manual operation: See ["Start Time"](#) on page 306

```
[ :SOURce<hw>]:BB:GNSS:ADGeneration:NAVIC:TOAData:DATE?
[ :SOURce<hw>]:BB:GNSS:ADGeneration:QZSS:TOAData:DATE?
[ :SOURce<hw>]:BB:GNSS:ADGeneration:BEIDou:TOAData:DATE?
[ :SOURce<hw>]:BB:GNSS:ADGeneration:GLONass:TOAData:DATE?
```

[:SOURCE<hw>]:BB:GNSS:ADGeneration:GALileo:TOADData:DATE?
[:SOURCE<hw>]:BB:GNSS:ADGeneration:GPS:TOADData:DATE?

Enabled for UTC or GLONASS timebase ([\[:SOURCE<hw>\]:BB:GNSS:ADGeneration:GPS:TOADData:TBASIS?](#)).

Queries the date for the assistance data in DMS format of the Gregorian calendar.

Parameters:

<Year>	integer	
	Range:	1980 to 9999
<Month>	integer	
	Range:	1 to 12
<Day>	integer	
	Range:	1 to 31

Example: See [Example "Generating GPS assistance data"](#) on page 596.

Usage: Query only

Manual operation: See ["Date"](#) on page 306

[:SOURCE<hw>]:BB:GNSS:ADGeneration:NAVIC:TOADData:TIME?
[:SOURCE<hw>]:BB:GNSS:ADGeneration:QZSS:TOADData:TIME?
[:SOURCE<hw>]:BB:GNSS:ADGeneration:BEIDou:TOADData:TIME?
[:SOURCE<hw>]:BB:GNSS:ADGeneration:GLONass:TOADData:TIME?
[:SOURCE<hw>]:BB:GNSS:ADGeneration:GALileo:TOADData:TIME?
[:SOURCE<hw>]:BB:GNSS:ADGeneration:GPS:TOADData:TIME?

Queries the exact start time of the assistance data in UTC time format.

Querying requires the UTC timebase or GLONASS timebase:

```
:SOURCE1:BB:GNSS:ADGeneration:GPS:TOADData:TBASIS UTC
:SOURCE1:BB:GNSS:ADGeneration:GPS:TOADData:TBASIS GLONASS
```

See also [\[:SOURCE<hw>\]:BB:GNSS:ADGeneration:QZSS:TOADData:TBASIS?](#) on page 599.

Parameters:

<Hour>	integer	
	Range:	0 to 23
<Minute>	integer	
	Range:	0 to 59
<Second>	float	
	Range:	0 to 59.999
	Increment:	0.001

Example: See [Example "Generating GPS assistance data"](#) on page 596.

Usage: Query only

Manual operation: See ["Time"](#) on page 306

```
[:SOURCE<hw>]:BB:GNSS:ADGeneration:NAVIC:TOADData:DURATION <Duration>
[:SOURCE<hw>]:BB:GNSS:ADGeneration:QZSS:TOADData:DURATION <Duration>
[:SOURCE<hw>]:BB:GNSS:ADGeneration:BEIDou:TOADData:DURATION <Duration>
[:SOURCE<hw>]:BB:GNSS:ADGeneration:GLONass:TOADData:DURATION
<Duration>
[:SOURCE<hw>]:BB:GNSS:ADGeneration:GALileo:TOADData:DURATION <Duration>
[:SOURCE<hw>]:BB:GNSS:ADGeneration:GPS:TOADData:DURATION <Duration>
```

Sets the duration of the assistance data.

Parameters:

```
<Duration>          float
                    Range:    1E-3 to 5E3
                    Increment: 1E-3
                    *RST:     1E-3
```

Example: See [Example"Generating GPS assistance data"](#) on page 596.

Manual operation: See ["Duration"](#) on page 307

```
[:SOURCE<hw>]:BB:GNSS:ADGeneration:NAVIC:TOADData:RESolution
<Resolution>
[:SOURCE<hw>]:BB:GNSS:ADGeneration:QZSS:TOADData:RESolution
<Resolution>
[:SOURCE<hw>]:BB:GNSS:ADGeneration:BEIDou:TOADData:RESolution
<Resolution>
[:SOURCE<hw>]:BB:GNSS:ADGeneration:GLONass:TOADData:RESolution
<Resolution>
[:SOURCE<hw>]:BB:GNSS:ADGeneration:GALileo:TOADData:RESolution
<Resolution>
[:SOURCE<hw>]:BB:GNSS:ADGeneration:GPS:TOADData:RESolution <Resolution>
```

Sets the resolution of the assistance data.

Parameters:

```
<Resolution>       float
                    Range:    1E-3 to 5
                    Increment: 1E-3
                    *RST:     1E-3
```

Example: See [Example"Generating GPS assistance data"](#) on page 596.

Manual operation: See ["Step"](#) on page 307

```
[:SOURCE<hw>]:BB:GNSS:ADGeneration:NAVIC:TOADData:TOWeek?
[:SOURCE<hw>]:BB:GNSS:ADGeneration:QZSS:TOADData:TOWeek?
[:SOURCE<hw>]:BB:GNSS:ADGeneration:BEIDou:TOADData:TOWeek?
[:SOURCE<hw>]:BB:GNSS:ADGeneration:GLONass:TOADData:TOWeek?
```

[:SOURce<hw>]:BB:GNSS:ADGeneration:GALileo:TOAData:TOWeek?
[:SOURce<hw>]:BB:GNSS:ADGeneration:GPS:TOAData:TOWeek?

Queries the Time of Week (TOW) of the assistance data for the related GNSS timebase.

See also [\[:SOURce<hw>\]:BB:GNSS:ADGeneration:QZSS:TOAData:TBASis?](#) on page 599.

Return values:

<TOW> integer
 Range: -604800 to 604800
 *RST: 0

Example: See [Example "Generating GPS assistance data"](#) on page 596.

Usage: Query only

Manual operation: See ["Time of Week"](#) on page 307

[:SOURce<hw>]:BB:GNSS:ADGeneration:NAVIC:TOAData:WNUMber?
[:SOURce<hw>]:BB:GNSS:ADGeneration:QZSS:TOAData:WNUMber?
[:SOURce<hw>]:BB:GNSS:ADGeneration:BEIDou:TOAData:WNUMber?
[:SOURce<hw>]:BB:GNSS:ADGeneration:GLONass:TOAData:WNUMber?
[:SOURce<hw>]:BB:GNSS:ADGeneration:GALileo:TOAData:WNUMber?
[:SOURce<hw>]:BB:GNSS:ADGeneration:GPS:TOAData:WNUMber?

Queries the week number (WN) of the assistance data for the related GNSS timebase.

See also [\[:SOURce<hw>\]:BB:GNSS:ADGeneration:QZSS:TOAData:TBASis?](#) on page 599.

Return values:

<WeekNumber> integer
 Range: 0 to 9999.0*53
 *RST: 0

Example: See [Example "Generating GPS assistance data"](#) on page 596.

Usage: Query only

Manual operation: See ["Week"](#) on page 306

[:SOURce<hw>]:BB:GNSS:ADGeneration:ACQuisition:CREate <Create>

Saves the current assistance data settings into the selected acquisition file. The file extension (*.rs_acq) is assigned automatically.

Parameters:

<Create> string
 Filename or complete file path

Example: See [Example "Generating GPS assistance data"](#) on page 596.

Manual operation: See ["Generate Acquisition"](#) on page 303

```
[[:SOURce<hw>]:BB:GNSS:ADGeneration:ALManac:CREate <Filename>
```

Saves the current assistance data settings into the selected almanac file.

Parameters:

<Filename> string
 Filename or complete file path
 The default extension is *.rs_al. It can be omitted in the filename.
 To save an almanac file as file with extension *.rs_yuma, specify it in the filename.

Example: See [Example"Generating GPS assistance data"](#) on page 596.

Manual operation: See ["Generate Almanac"](#) on page 302

```
[[:SOURce<hw>]:BB:GNSS:ADGeneration:NAVigation:CREate <Filename>
```

Saves the current assistance data settings into the selected navigation file. Assistance data settings are saved as navigation file with the specific file extensions *.rs_nav or into RINEX files with extension .10n.

Parameters:

<Filename> string
 Filename or complete file path

Example: See [Example"Generating GPS assistance data"](#) on page 596.

Manual operation: See ["Generate Navigation"](#) on page 303

22.18 Monitoring and real-time commands

Example: Configuring GNSS signal, receiver and simulation time

```
*RST
SOURce1:BB:GNSS:TMODe NAV
SOURce1:BB:GNSS:SYSTem:GPS:STAtE 1
SOURce1:BB:GNSS:SYSTem:GALileo:STAtE 1
SOURce1:BB:GNSS:SYSTem:BEIDou:STAtE 1
SOURce1:BB:GNSS:RECeiver:V1:POSition MOV
SOURce1:BB:GNSS:RECeiver:V1:LOCation:WAYPoints:FILE "Melbourne_Car_Motion.xtd"

SOURce1:BB:GNSS:TIME:STArt:GPS:WNUMber?
// Response: 1780
SOURce1:BB:GNSS:TIME:STArt:GPS:TOWeek?
// Response: 280816
SOURce1:BB:GNSS:TIME:STArt:TBASis UTC
SOURce1:BB:GNSS:TIME:STArt:UTC:DATE?
// Response: 2014,2,19
```

```

SOURCE1:BB:GNSS:TIME:START:UTC:TIME?
// Response: 6,0,0

SOURCE1:BB:GNSS:RECEIVER:V1:ENVIRONMENT:MODEL MPAT
SOURCE1:BB:GNSS:SVID1:GPS:MPATH:V1:A1:ECHOS:COUNT 1
SOURCE1:BB:GNSS:SVID1:GPS:MPATH:V1:A1:ECHO1:ICPHASE 100
SOURCE1:BB:GNSS:SVID1:GPS:MPATH:V1:A1:ECHO1:POWER -5
SOURCE1:BB:GNSS:SVID1:GPS:MPATH:V1:A1:ECHO1:CPDRIFT 50
SOURCE1:BB:GNSS:STATE 1
SOURCE1:BB:GNSS:SIMULATION:INFO?
// Response: L1 / GPS,Galileo,BeiDou

```

Example: Configuring the simulation monitor

```

SOURCE1:BB:GNSS:MONITOR1:DISPLAY SKY

SOURCE1:BB:GNSS:MONITOR2:DISPLAY POW
SOURCE1:BB:GNSS:MONITOR2:DISPLAY:POWER:SYSTEM:GPS:SIGNAL:L1BAND:CA 1
SOURCE1:BB:GNSS:MONITOR2:DISPLAY:POWER:SYSTEM:GALILEO:SIGNAL:L1BAND:E1OS 1
SOURCE1:BB:GNSS:MONITOR2:DISPLAY:POWER:SYSTEM:GLONASS:SIGNAL:L1BAND:CA 1
SOURCE1:BB:GNSS:MONITOR2:DISPLAY:POWER:SYSTEM:BEIDOU:SIGNAL:L1BAND:B1I 1

SOURCE1:BB:GNSS:MONITOR1:DISPLAY MAP
SOURCE1:BB:GNSS:MONITOR1:DISPLAY:MAP:AXIS GRID
SOURCE1:BB:GNSS:MONITOR2:DISPLAY TRAC
SOURCE1:BB:GNSS:MONITOR2:DISPLAY:TRACKS:SHOW 1

SOURCE1:BB:GNSS:MONITOR2:DISPLAY TRAJ
SOURCE1:BB:GNSS:MONITOR2:DISPLAY:TRAJECTORY:SYSTEM GPS
SOURCE1:BB:GNSS:MONITOR2:DISPLAY:TRAJECTORY:SVID 1

SOURCE1:BB:GNSS:MONITOR2:DISPLAY CHANNELS
SOURCE1:BB:GNSS:MONITOR2:DISPLAY:CHANNELS:USED?
// Response: 33
SOURCE1:BB:GNSS:MONITOR2:DISPLAY:CHANNELS:ALLOCATED?
// Response: 48

```

Example: Retrieving real-time settings

```

*RST
SOURCE1:BB:GNSS:TMODE NAV
SOURCE1:BB:GNSS:SYSTEM:GPS:STATE 1
SOURCE1:BB:GNSS:SYSTEM:GALILEO:STATE 1
SOURCE1:BB:GNSS:SYSTEM:BEIDOU:STATE 1
SOURCE1:BB:GNSS:RECEIVER:V1:POSITION MOV
SOURCE1:BB:GNSS:RECEIVER:V1:LOCATION:WAYPOINTS:FILE "Melbourne_Car_Motion.xtd"

SOURCE1:BB:GNSS:TIME:START:GPS:WNUMBER?
// Response: 1780
SOURCE1:BB:GNSS:TIME:START:GPS:TOWEEK?
// Response: 280816
SOURCE1:BB:GNSS:TIME:START:TBASIS UTC
SOURCE1:BB:GNSS:TIME:START:UTC:DATE?

```

```

// Response: 2014,2,19
SOURCE1:BB:GNSS:TIME:START:UTC:TIME?
// Response: 6,0,0

SOURCE1:BB:GNSS:STATE 1
SOURCE1:BB:GNSS:SIMulation:INFO?
// Response: "L1 / GPS,Galileo,BeiDou"
SOURCE1:BB:GNSS:RT:HWTime?
// Response in s: 8.35
// Elapsed time since simulation start.

// Query space vehicle real-time data.
SOURCE1:BB:GNSS:RT:GPS:SVID2:AZIMuth? GST,1780,280818
// Response in degree: 193.484716876694
SOURCE1:BB:GNSS:RT:GPS:SVID2:ELEVation? GST,1780,280818
// Response in degree: -17.3132866460052
SOURCE1:BB:GNSS:RT:HDOP?
// Response: 0.61
SOURCE1:BB:GNSS:RT:PDOP?
// Response: 1.07
SOURCE1:BB:GNSS:RT:VDOP?
// Response: 0.89

// Query the receiver real-time data.
SOURCE1:BB:GNSS:RT:RECeiver1:RLOCation:COORDinates:DMS? GPS,1780,280850
// Response <LongitudeDeg>,<LongitudeMin>,<LongitudeSec>,<LongitudeDir>,
// <LatitudeDeg>,<LatitudeMin>,<LatitudeSec>,<LatitudeDir>,<Altitude>:
// 144,57,59.1954000000,EAST,37,48,37.6154000000,SOUT,100.037000
SOURCE1:BB:GNSS:RT:RECeiver1:RLOCation:COORDinates:DECimal? GPS,1780,280850
// Response <Longitude>,<Latitude>,<Altitude>:
// 144.9664431600000,-37.8104487300000,100.037000
SOURCE1:BB:GNSS:RT:RECeiver1:RVELocity? GPS,1780,280850
// Response in m/s: 987.654321
SOURCE1:BB:GNSS:RT:RPVT? GPS,1780,280850
// Response <Longitude>,<Latitude>,<Altitude>,<Velocity>:
// 144.9664431600000,-37.8104487300000,100.037000,0.000000
SOURCE1:BB:GNSS:RT:RATTitude? GPS,1780,280850
// Response <Yaw>,<Pitch>,<Roll>:
// 0.33,0,0

```

Commands:

- [Monitoring commands](#).....605
- [Real-time commands](#).....612

22.18.1 Monitoring commands

[:SOURCE<hw>]:BB:GNSS:MONitor<ch>:DISPlay	607
[:SOURCE<hw>]:BB:GNSS:MONitor<ch>:DISPlay:VEHicle	607
[:SOURCE<hw>]:BB:GNSS:MONitor<ch>:DISPlay:ANTenna	608
[:SOURCE<hw>]:BB:GNSS:MONitor<ch>:DISPlay:MAP:AXIS	608

Monitoring and real-time commands

[SOURce<hw>]:BB:GNSS:MONitor<ch>:DISPlay:TRACks:SHOW.....	608
[SOURce<hw>]:BB:GNSS:MONitor<ch>:DISPlay:TRAJectory:SVID.....	608
[SOURce<hw>]:BB:GNSS:MONitor<ch>:DISPlay:TRAJectory:SYSTem.....	609
[SOURce<hw>]:BB:GNSS:MONitor<ch>:DISPlay:POWer:ECHoes.....	609
[SOURce<hw>]:BB:GNSS:MONitor<ch>:DISPlay:POWer:SYSTem:SBAS:SIGNal: L5Band:EL5S.....	610
[SOURce<hw>]:BB:GNSS:MONitor<ch>:DISPlay:POWer:SYSTem:SBAS:SIGNal: L1Band:CA.....	610
[SOURce<hw>]:BB:GNSS:MONitor<ch>:DISPlay:POWer:SYSTem:NAVic:SIGNal: L5Band:SPS.....	610
[SOURce<hw>]:BB:GNSS:MONitor<ch>:DISPlay:POWer:SYSTem:QZSS:SIGNal: L5Band:L5S.....	610
[SOURce<hw>]:BB:GNSS:MONitor<ch>:DISPlay:POWer:SYSTem:QZSS:SIGNal: L2Band:L2C.....	610
[SOURce<hw>]:BB:GNSS:MONitor<ch>:DISPlay:POWer:SYSTem:QZSS:SIGNal: L1Band:L1C.....	610
[SOURce<hw>]:BB:GNSS:MONitor<ch>:DISPlay:POWer:SYSTem:QZSS:SIGNal: L1Band:CA.....	610
[SOURce<hw>]:BB:GNSS:MONitor<ch>:DISPlay:POWer:SYSTem:BEIDou:SIGNal: L5Band:B2I.....	610
[SOURce<hw>]:BB:GNSS:MONitor<ch>:DISPlay:POWer:SYSTem:BEIDou:SIGNal: L5Band:B2B.....	610
[SOURce<hw>]:BB:GNSS:MONitor<ch>:DISPlay:POWer:SYSTem:BEIDou:SIGNal: L5Band:B2A.....	610
[SOURce<hw>]:BB:GNSS:MONitor<ch>:DISPlay:POWer:SYSTem:BEIDou:SIGNal: L2Band:B3I.....	610
[SOURce<hw>]:BB:GNSS:MONitor<ch>:DISPlay:POWer:SYSTem:BEIDou:SIGNal: L1Band:B1I.....	610
[SOURce<hw>]:BB:GNSS:MONitor<ch>:DISPlay:POWer:SYSTem:BEIDou:SIGNal: L1Band:B1C.....	610
[SOURce<hw>]:BB:GNSS:MONitor<ch>:DISPlay:POWer:SYSTem:GLONass:SIGNal: L5Band:L3CDma.....	610
[SOURce<hw>]:BB:GNSS:MONitor<ch>:DISPlay:POWer:SYSTem:GLONass:SIGNal: L2Band:L2CDma.....	610
[SOURce<hw>]:BB:GNSS:MONitor<ch>:DISPlay:POWer:SYSTem:GLONass:SIGNal: L2Band:CA.....	610
[SOURce<hw>]:BB:GNSS:MONitor<ch>:DISPlay:POWer:SYSTem:GLONass:SIGNal: L1Band:L1CDma.....	610
[SOURce<hw>]:BB:GNSS:MONitor<ch>:DISPlay:POWer:SYSTem:GLONass:SIGNal: L1Band:CA.....	610
[SOURce<hw>]:BB:GNSS:MONitor<ch>:DISPlay:POWer:SYSTem:GALileo:SIGNal: L5Band:E5B.....	610
[SOURce<hw>]:BB:GNSS:MONitor<ch>:DISPlay:POWer:SYSTem:GALileo:SIGNal: L5Band:E5A.....	610
[SOURce<hw>]:BB:GNSS:MONitor<ch>:DISPlay:POWer:SYSTem:GALileo:SIGNal: L2Band:E6PRs.....	610
[SOURce<hw>]:BB:GNSS:MONitor<ch>:DISPlay:POWer:SYSTem:GALileo:SIGNal: L2Band:E6S.....	610
[SOURce<hw>]:BB:GNSS:MONitor<ch>:DISPlay:POWer:SYSTem:GALileo:SIGNal: L1Band:E1OS.....	610

<code>[SOURce<hw>]:BB:GNSS:MONitor<ch>:DISPlay:POWer:SYSTem:GALileo:SIGNal: L1Band:E1PRs</code>	610
<code>[SOURce<hw>]:BB:GNSS:MONitor<ch>:DISPlay:POWer:SYSTem:GPS:SIGNal: L5Band:L5S</code>	611
<code>[SOURce<hw>]:BB:GNSS:MONitor<ch>:DISPlay:POWer:SYSTem:GPS:SIGNal: L2Band:CA</code>	611
<code>[SOURce<hw>]:BB:GNSS:MONitor<ch>:DISPlay:POWer:SYSTem:GPS:SIGNal: L2Band:L2C</code>	611
<code>[SOURce<hw>]:BB:GNSS:MONitor<ch>:DISPlay:POWer:SYSTem:GPS:SIGNal: L2Band:M</code>	611
<code>[SOURce<hw>]:BB:GNSS:MONitor<ch>:DISPlay:POWer:SYSTem:GPS:SIGNal:L2Band:P</code>	611
<code>[SOURce<hw>]:BB:GNSS:MONitor<ch>:DISPlay:POWer:SYSTem:GPS:SIGNal: L2Band:PY</code>	611
<code>[SOURce<hw>]:BB:GNSS:MONitor<ch>:DISPlay:POWer:SYSTem:GPS:SIGNal: L1Band:L1C</code>	611
<code>[SOURce<hw>]:BB:GNSS:MONitor<ch>:DISPlay:POWer:SYSTem:GPS:SIGNal: L1Band:M</code>	611
<code>[SOURce<hw>]:BB:GNSS:MONitor<ch>:DISPlay:POWer:SYSTem:GPS:SIGNal:L1Band:P</code>	611
<code>[SOURce<hw>]:BB:GNSS:MONitor<ch>:DISPlay:POWer:SYSTem:GPS:SIGNal: L1Band:PY</code>	611
<code>[SOURce<hw>]:BB:GNSS:MONitor<ch>:DISPlay:POWer:SYSTem:GPS:SIGNal: L1Band:CA</code>	611
<code>[SOURce<hw>]:BB:GNSS:MONitor<ch>:DISPlay:STReam</code>	611
<code>[SOURce<hw>]:BB:GNSS:MONitor<ch>:DISPlay:CHANnels:ALLocated?</code>	611
<code>[SOURce<hw>]:BB:GNSS:MONitor<ch>:DISPlay:CHANnels:USED?</code>	612

`[SOURce<hw>]:BB:GNSS:MONitor<ch>:DISPlay <DisplayType>`

Switches between the available views.

Parameters:

`<DisplayType>` SKY | MAP | POWer | TRAjectory | ATTitude | TRACKs |
CHANnels
*RST: SKY

Example: See [Example "Configuring the simulation monitor"](#) on page 604.

Manual operation: See ["Display"](#) on page 37

`[SOURce<hw>]:BB:GNSS:MONitor<ch>:DISPlay:VEHicle <Vehicle>`

Sets the vehicle for that the information displayed in the "Simulation Monitor" applies.

Parameters:

`<Vehicle>` V1 | V2
*RST: V1

Example: See [Example "Configuring the simulation monitor"](#) on page 604.

Options: R&S SMW-B9

Manual operation: See ["Vehicle"](#) on page 283

[:SOURce<hw>]:BB:GNSS:MONitor<ch>:DISPlay:ANTenna <Antenna>

Sets the antenna for that the information displayed in the "Simulation Monitor" applies.

Parameters:

<Antenna> A1 | A2 | A3 | A4 | A5 | A6
*RST: A1

Example: See [Example"Configuring the simulation monitor"](#) on page 604.

Options: R&S SMW-B9

Manual operation: See ["Antenna"](#) on page 283

[:SOURce<hw>]:BB:GNSS:MONitor<ch>:DISPlay:MAP:AXIS <AxisType>

Changes the axis type in the "Map View" display.

Parameters:

<AxisType> GRID | CIRCles
*RST: GRID

Example: See [Example"Configuring the simulation monitor"](#) on page 604.

Manual operation: See ["Axis"](#) on page 44

[:SOURce<hw>]:BB:GNSS:MONitor<ch>:DISPlay:TRACKs:SHOW <ShowTracks>

Enables display of the current satellite positions and their orbits.

Parameters:

<ShowTracks> 1 | ON | 0 | OFF
*RST: 0

Example: See [Example"Configuring the simulation monitor"](#) on page 604.

Manual operation: See ["Show Tracks"](#) on page 43

[:SOURce<hw>]:BB:GNSS:MONitor<ch>:DISPlay:TRAJectory:SVID <SvId>

Selects the SV ID which elevation/azimuth variation over 24 hours is displayed.

Parameters:

<SvId> 1 | 2 | 3 | 5 | 4 | 6 | 7 | 8 | 9 | 10 | 11 | 12 | 13 | 14 | 15 | 16 | 17 |
 19 | 18 | 20 | 21 | 22 | 23 | 24 | 25 | 26 | 27 | 28 | 29 | 30 | 31 |
 32 | 33 | 34 | 35 | 36 | 37 | 38 | 39 | 40 | 41 | 42 | 43 | 44 | 45 |
 46 | 47 | 48 | 49 | 50 | 51 | 52 | 53 | 54 | 55 | 56 | 57 | 58 | 59 |
 60 | 61 | 62 | 63 | 64 | 65 | 66 | 67 | 68 | 69 | 70 | 71 | 72 | 73 |
 74 | 75 | 76 | 77 | 78 | 79 | 80 | 81 | 82 | 83 | 84 | 85 | 86 | 87 |
 88 | 89 | 90 | 91 | 92 | 93 | 94 | 95 | 96 | 97 | 98 | 99 | 100 | 101 |
 102 | 103 | 104 | 105 | 106 | 107 | 108 | 109 | 110 | 111 | 112 |
 113 | 114 | 115 | 116 | 117 | 118 | 119 | 120 | 121 | 122 | 123 |
 124 | 125 | 126 | 127 | 128 | 129 | 130 | 131 | 132 | 133 | 134 |
 135 | 136 | 137 | 138 | 139 | 140 | 141 | 142 | 143 | 144 | 145 |
 146 | 147 | 148 | 149 | 150 | 151 | 152 | 153 | 154 | 155 | 156 |
 157 | 158 | 159 | 160 | 161 | 162 | 163 | 164 | 165 | 166 | 167 |
 168 | 169 | 170 | 171 | 172 | 173 | 174 | 175 | 176 | 177 | 178 |
 179 | 180 | 181 | 182 | 183 | 184 | 185 | 186 | 187 | 188 | 189 |
 190 | 191 | 192 | 193 | 194 | 195 | 196 | 197 | 198 | 199 | 200 |
 ALL

Example: See [Example"Configuring the simulation monitor"](#) on page 604.

Manual operation: See ["SV-ID"](#) on page 44

[:SOURce<hw>]:BB:GNSS:MONitor<ch>:DISPlay:TRAJectory:SYSTEM <System>

Selects the GNSS system which elevation/azimuth variation over 24 hours is displayed.

Parameters:

<System> GPS | GALileo | GLONass | BEIDou | QZSS | SBAS
 *RST: GPS

Example: See [Example"Configuring the simulation monitor"](#) on page 604.

Manual operation: See ["System"](#) on page 44

[:SOURce<hw>]:BB:GNSS:MONitor<ch>:DISPlay:POWER:ECHoes <ShowEchoes>

If enabled, the "Power View" indicates also the echoes per SV.

Parameters:

<ShowEchoes> 1 | ON | 0 | OFF
 *RST: 1

Example: See [Example"Configuring the simulation monitor"](#) on page 604.

Manual operation: See ["Show Echoes"](#) on page 43

```

[:SOURce<hw>]:BB:GNSS:MONitor<ch>:DISPlay:POWer:SYSTem:SBAS:SIGNAL:
L5Band:EL5S <SignalState>
[:SOURce<hw>]:BB:GNSS:MONitor<ch>:DISPlay:POWer:SYSTem:SBAS:SIGNAL:
L1Band:CA <SignalState>
[:SOURce<hw>]:BB:GNSS:MONitor<ch>:DISPlay:POWer:SYSTem:NAVic:SIGNAL:
L5Band:SPS <SignalState>
[:SOURce<hw>]:BB:GNSS:MONitor<ch>:DISPlay:POWer:SYSTem:QZSS:SIGNAL:
L5Band:L5S <SignalState>
[:SOURce<hw>]:BB:GNSS:MONitor<ch>:DISPlay:POWer:SYSTem:QZSS:SIGNAL:
L2Band:L2C <SignalState>
[:SOURce<hw>]:BB:GNSS:MONitor<ch>:DISPlay:POWer:SYSTem:QZSS:SIGNAL:
L1Band:L1C <SignalState>
[:SOURce<hw>]:BB:GNSS:MONitor<ch>:DISPlay:POWer:SYSTem:QZSS:SIGNAL:
L1Band:CA <SignalState>
[:SOURce<hw>]:BB:GNSS:MONitor<ch>:DISPlay:POWer:SYSTem:BEIDou:
SIGNAL:L5Band:B2I <SignalState>
[:SOURce<hw>]:BB:GNSS:MONitor<ch>:DISPlay:POWer:SYSTem:BEIDou:
SIGNAL:L5Band:B2B <SignalState>
[:SOURce<hw>]:BB:GNSS:MONitor<ch>:DISPlay:POWer:SYSTem:BEIDou:
SIGNAL:L5Band:B2A <SignalState>
[:SOURce<hw>]:BB:GNSS:MONitor<ch>:DISPlay:POWer:SYSTem:BEIDou:
SIGNAL:L2Band:B3I <SignalState>
[:SOURce<hw>]:BB:GNSS:MONitor<ch>:DISPlay:POWer:SYSTem:BEIDou:
SIGNAL:L1Band:B1I <SignalState>
[:SOURce<hw>]:BB:GNSS:MONitor<ch>:DISPlay:POWer:SYSTem:BEIDou:
SIGNAL:L1Band:B1C <SignalState>
[:SOURce<hw>]:BB:GNSS:MONitor<ch>:DISPlay:POWer:SYSTem:GLONass:
SIGNAL:L5Band:L3CDma <SignalState>
[:SOURce<hw>]:BB:GNSS:MONitor<ch>:DISPlay:POWer:SYSTem:GLONass:
SIGNAL:L2Band:L2CDma <SignalState>
[:SOURce<hw>]:BB:GNSS:MONitor<ch>:DISPlay:POWer:SYSTem:GLONass:
SIGNAL:L2Band:CA <SignalState>
[:SOURce<hw>]:BB:GNSS:MONitor<ch>:DISPlay:POWer:SYSTem:GLONass:
SIGNAL:L1Band:L1CDma <SignalState>
[:SOURce<hw>]:BB:GNSS:MONitor<ch>:DISPlay:POWer:SYSTem:GLONass:
SIGNAL:L1Band:CA <SignalState>
[:SOURce<hw>]:BB:GNSS:MONitor<ch>:DISPlay:POWer:SYSTem:GALileo:
SIGNAL:L5Band:E5B <SignalState>
[:SOURce<hw>]:BB:GNSS:MONitor<ch>:DISPlay:POWer:SYSTem:GALileo:
SIGNAL:L5Band:E5A <SignalState>
[:SOURce<hw>]:BB:GNSS:MONitor<ch>:DISPlay:POWer:SYSTem:GALileo:
SIGNAL:L2Band:E6PRs <SignalState>
[:SOURce<hw>]:BB:GNSS:MONitor<ch>:DISPlay:POWer:SYSTem:GALileo:
SIGNAL:L2Band:E6S <SignalState>
[:SOURce<hw>]:BB:GNSS:MONitor<ch>:DISPlay:POWer:SYSTem:GALileo:
SIGNAL:L1Band:E1OS <SignalState>
[:SOURce<hw>]:BB:GNSS:MONitor<ch>:DISPlay:POWer:SYSTem:GALileo:
SIGNAL:L1Band:E1PRs <SignalState>

```

```
[:SOURce<hw>]:BB:GNSS:MONitor<ch>:DISPlay:POWer:SYSTem:GPS:SIGNAL:
  L5Band:L5S <SignalState>
[:SOURce<hw>]:BB:GNSS:MONitor<ch>:DISPlay:POWer:SYSTem:GPS:SIGNAL:
  L2Band:CA <SignalState>
[:SOURce<hw>]:BB:GNSS:MONitor<ch>:DISPlay:POWer:SYSTem:GPS:SIGNAL:
  L2Band:L2C <SignalState>
[:SOURce<hw>]:BB:GNSS:MONitor<ch>:DISPlay:POWer:SYSTem:GPS:SIGNAL:
  L2Band:M <SignalState>
[:SOURce<hw>]:BB:GNSS:MONitor<ch>:DISPlay:POWer:SYSTem:GPS:SIGNAL:
  L2Band:P <SignalState>
[:SOURce<hw>]:BB:GNSS:MONitor<ch>:DISPlay:POWer:SYSTem:GPS:SIGNAL:
  L2Band:PY <SignalState>
[:SOURce<hw>]:BB:GNSS:MONitor<ch>:DISPlay:POWer:SYSTem:GPS:SIGNAL:
  L1Band:L1C <SignalState>
[:SOURce<hw>]:BB:GNSS:MONitor<ch>:DISPlay:POWer:SYSTem:GPS:SIGNAL:
  L1Band:M <SignalState>
[:SOURce<hw>]:BB:GNSS:MONitor<ch>:DISPlay:POWer:SYSTem:GPS:SIGNAL:
  L1Band:P <SignalState>
[:SOURce<hw>]:BB:GNSS:MONitor<ch>:DISPlay:POWer:SYSTem:GPS:SIGNAL:
  L1Band:PY <SignalState>
[:SOURce<hw>]:BB:GNSS:MONitor<ch>:DISPlay:POWer:SYSTem:GPS:SIGNAL:
  L1Band:CA <SignalState>
```

Defines the signals to be visualized on the "Power View" graph.

Parameters:

<SignalState> 1 | ON | 0 | OFF

Example: See [Example "Configuring the simulation monitor"](#) on page 604.

Manual operation: See ["View Settings"](#) on page 43

```
[:SOURce<hw>]:BB:GNSS:MONitor<ch>:DISPlay:STReam <Stream>
```

In GNSS advanced mode, switches between available streams in "Display Type" > "HW Channels".

For the display type, see [\[:SOURce<hw>\]:BB:GNSS:MONitor<ch>:DISPlay](#) on page 607.

Parameters:

<Stream> S1 | S2 | S3 | S4 | S5 | S6

*RST: S1

Example: See [Example "Multi-band GNSS signal"](#) on page 630

Options: Requires R&S SMW-B9

Manual operation: See ["Stream"](#) on page 284

```
[:SOURce<hw>]:BB:GNSS:MONitor<ch>:DISPlay:CHANnels:ALLocated?
```

Queries the maximum number of allocated channels.

The maximum number of allocated channels depends on the installed options, see [Chapter G, "Channel budget"](#), on page 682.

Return values:

<AllocatedChans> integer
 Range: 0 to depends on installed options
 Increment: 1

Example: See [Example "Configuring the simulation monitor"](#) on page 604

Usage: Query only

Manual operation: See ["Channels"](#) on page 44

[:SOURce<hw>]:BB:GNSS:MONitor<ch>:DISPlay:CHANnels:USED?

Queries the number of active channels.

The maximum number of active channels depends on the installed options, see [Chapter G, "Channel budget"](#), on page 682.

Return values:

<UsedChannels> integer
 Range: 0 to depends on installed options
 Increment: 1
 *RST: 0
 The *RST value depends on the installed GNSS system option, e.g. for GPS :
 *RST: 11

Example: See [Example "Configuring the simulation monitor"](#) on page 604

Usage: Query only

Manual operation: See ["Channels"](#) on page 44

22.18.2 Real-time commands

[:SOURce<hw>]:BB:GNSS:RT[:STReam<ch>]:ACTive:SYSTems?	613
[:SOURce<hw>]:BB:GNSS:RT[:STReam<ch>]:SBAS:ACTive:SIGNals?	613
[:SOURce<hw>]:BB:GNSS:RT[:STReam<ch>]:QZSS:ACTive:SIGNals?	613
[:SOURce<hw>]:BB:GNSS:RT[:STReam<ch>]:NAVic:ACTive:SIGNals?	613
[:SOURce<hw>]:BB:GNSS:RT[:STReam<ch>]:BEIDou:ACTive:SIGNals?	613
[:SOURce<hw>]:BB:GNSS:RT[:STReam<ch>]:GLONass:ACTive:SIGNals?	613
[:SOURce<hw>]:BB:GNSS:RT[:STReam<ch>]:GALileo:ACTive:SIGNals?	613
[:SOURce<hw>]:BB:GNSS:RT[:STReam<ch>]:GPS:ACTive:SIGNals?	613
[:SOURce<hw>]:BB:GNSS:RT:SBAS:SVID<ch>:AZIMuth?	614
[:SOURce<hw>]:BB:GNSS:RT:NAVic:SVID<ch>:AZIMuth?	614
[:SOURce<hw>]:BB:GNSS:RT:QZSS:SVID<ch>:AZIMuth?	614
[:SOURce<hw>]:BB:GNSS:RT:BEIDou:SVID<ch>:AZIMuth?	614
[:SOURce<hw>]:BB:GNSS:RT:GLONass:SVID<ch>:AZIMuth?	614
[:SOURce<hw>]:BB:GNSS:RT:GALileo:SVID<ch>:AZIMuth?	614

<code>[SOURce<hw>]:BB:GNSS:RT:GPS:SVID<ch>:AZIMuth?</code>	614
<code>[SOURce<hw>]:BB:GNSS:RT:SBAS:SVID<ch>:ELEVation?</code>	615
<code>[SOURce<hw>]:BB:GNSS:RT:NAVic:SVID<ch>:ELEVation?</code>	615
<code>[SOURce<hw>]:BB:GNSS:RT:QZSS:SVID<ch>:ELEVation?</code>	615
<code>[SOURce<hw>]:BB:GNSS:RT:BEIDou:SVID<ch>:ELEVation?</code>	615
<code>[SOURce<hw>]:BB:GNSS:RT:GLONass:SVID<ch>:ELEVation?</code>	615
<code>[SOURce<hw>]:BB:GNSS:RT:GALileo:SVID<ch>:ELEVation?</code>	615
<code>[SOURce<hw>]:BB:GNSS:RT:GPS:SVID<ch>:ELEVation?</code>	615
<code>[SOURce<hw>]:BB:GNSS:RT:HDOP?</code>	616
<code>[SOURce<hw>]:BB:GNSS:RT:PDOP?</code>	617
<code>[SOURce<hw>]:BB:GNSS:RT:VDOP?</code>	617
<code>[SOURce<hw>]:BB:GNSS:RT:RECeiver[V<st>]:RLOCation:COORDinates:DECimal?</code>	617
<code>[SOURce<hw>]:BB:GNSS:RT:RECeiver[V<st>]:RLOCation:COORDinates:DMS?</code>	618
<code>[SOURce<hw>]:BB:GNSS:RT:RATTitude?</code>	620
<code>[SOURce<hw>]:BB:GNSS:RT:RPVT?</code>	621
<code>[SOURce<hw>]:BB:GNSS:RT:RECeiver[V<st>]:RVELocity?</code>	623

`[SOURce<hw>]:BB:GNSS:RT[:STReam<ch>]:ACTive:SYSTems?`

Queries active GNSS in a comma-separated string.

Return values:

<ActiveSystems> string

Example: `SOURce1:BB:GNSS:RT:ACTive:SYSTems?`
 `// Response: "GPS"`

Usage: Query only

`[SOURce<hw>]:BB:GNSS:RT[:STReam<ch>]:SBAS:ACTive:SIGNals?`
`[SOURce<hw>]:BB:GNSS:RT[:STReam<ch>]:QZSS:ACTive:SIGNals?`
`[SOURce<hw>]:BB:GNSS:RT[:STReam<ch>]:NAVic:ACTive:SIGNals?`
`[SOURce<hw>]:BB:GNSS:RT[:STReam<ch>]:BEIDou:ACTive:SIGNals?`
`[SOURce<hw>]:BB:GNSS:RT[:STReam<ch>]:GLONass:ACTive:SIGNals?`
`[SOURce<hw>]:BB:GNSS:RT[:STReam<ch>]:GALileo:ACTive:SIGNals?`
`[SOURce<hw>]:BB:GNSS:RT[:STReam<ch>]:GPS:ACTive:SIGNals?`

Queries active signals of a GNSS in a comma-separated list.

Return values:

<ActiveSignals> string

Example: `SOURce1:BB:GNSS:RT:GPS:ACTive:SIGNals?`
 `// Response: 1,CA`

Usage: Query only

```

[:SOURCE<hw>]:BB:GNSS:RT:SBAS:SVID<ch>:AZIMuth? <TimeBasis>, <Year>,
    <Month>, <Day>, <Hour>, <Minutes>, <Seconds>, <WeekNumber>,
    <TimeOfWeek>
[:SOURCE<hw>]:BB:GNSS:RT:NAVIC:SVID<ch>:AZIMuth? <TimeBasis>, <Year>,
    <Month>, <Day>, <Hour>, <Minutes>, <Seconds>, <WeekNumber>,
    <TimeOfWeek>
[:SOURCE<hw>]:BB:GNSS:RT:QZSS:SVID<ch>:AZIMuth? <TimeBasis>, <Year>,
    <Month>, <Day>, <Hour>, <Minutes>, <Seconds>, <WeekNumber>,
    <TimeOfWeek>
[:SOURCE<hw>]:BB:GNSS:RT:BEIDOU:SVID<ch>:AZIMuth? <TimeBasis>, <Year>,
    <Month>, <Day>, <Hour>, <Minutes>, <Seconds>, <WeekNumber>,
    <TimeOfWeek>
[:SOURCE<hw>]:BB:GNSS:RT:GLONASS:SVID<ch>:AZIMuth? <TimeBasis>,
    <Year>, <Month>, <Day>, <Hour>, <Minutes>, <Seconds>, <WeekNumber>,
    <TimeOfWeek>
[:SOURCE<hw>]:BB:GNSS:RT:GALILEO:SVID<ch>:AZIMuth? <TimeBasis>, <Year>,
    <Month>, <Day>, <Hour>, <Minutes>, <Seconds>, <WeekNumber>,
    <TimeOfWeek>
[:SOURCE<hw>]:BB:GNSS:RT:GPS:SVID<ch>:AZIMuth? <TimeBasis>, <Year>,
    <Month>, <Day>, <Hour>, <Minutes>, <Seconds>, <WeekNumber>,
    <TimeOfWeek>

```

Queries the satellite azimuth in the selected moment of time. The required query parameters, depend on the selected timebase.

Query parameters:

<TimeBasis>	UTC GPS GST GLO BDT *RST: UTC
<Year>	integer Required for TimeBasis = UTC Range: 1980 to 9999
<Month>	integer Required for TimeBasis = UTC Range: 1 to 12
<Day>	integer Required for TimeBasis = UTC Range: 1 to 31
<Hour>	integer Required for TimeBasis = UTC Range: 0 to 23
<Minutes>	integer Required for TimeBasis = UTC Range: 0 to 59

<Seconds>	float Required for <code>TimeBasis = UTC</code> Range: 0 to 59.999 Increment: 0.001
<WeekNumber>	integer Required for <code>TimeBasis = GPS GST BDT</code> Range: 0 to 529947
<TimeOfWeek>	float Required for <code>TimeBasis = GPS GST BDT</code> Range: 0 to 604799.999 Increment: 0.001

Return values:

<Azimuth> float

Example: See [Example"Retrieving real-time settings"](#) on page 604.

Usage: Query only

[[:SOURce<hw>]:BB:GNSS:RT:SBAS:SVID<ch>:ELEVation? <TimeBasis>, <Year>, <Month>, <Day>, <Hour>, <Minutes>, <Seconds>, <WeekNumber>, <TimeOfWeek>

[[:SOURce<hw>]:BB:GNSS:RT:NAVic:SVID<ch>:ELEVation? <TimeBasis>, <Year>, <Month>, <Day>, <Hour>, <Minutes>, <Seconds>, <WeekNumber>, <TimeOfWeek>

[[:SOURce<hw>]:BB:GNSS:RT:QZSS:SVID<ch>:ELEVation? <TimeBasis>, <Year>, <Month>, <Day>, <Hour>, <Minutes>, <Seconds>, <WeekNumber>, <TimeOfWeek>

[[:SOURce<hw>]:BB:GNSS:RT:BEIDou:SVID<ch>:ELEVation? <TimeBasis>, <Year>, <Month>, <Day>, <Hour>, <Minutes>, <Seconds>, <WeekNumber>, <TimeOfWeek>

[[:SOURce<hw>]:BB:GNSS:RT:GLONass:SVID<ch>:ELEVation? <TimeBasis>, <Year>, <Month>, <Day>, <Hour>, <Minutes>, <Seconds>, <WeekNumber>, <TimeOfWeek>

[[:SOURce<hw>]:BB:GNSS:RT:GALileo:SVID<ch>:ELEVation? <TimeBasis>, <Year>, <Month>, <Day>, <Hour>, <Minutes>, <Seconds>, <WeekNumber>, <TimeOfWeek>

[[:SOURce<hw>]:BB:GNSS:RT:GPS:SVID<ch>:ELEVation? <TimeBasis>, <Year>, <Month>, <Day>, <Hour>, <Minutes>, <Seconds>, <WeekNumber>, <TimeOfWeek>

Queries the satellite elevation in the selected moment of time. The required query parameters, depend on the selected timebase.

Query parameters:

<TimeBasis> UTC | GPS | GST | GLO | BDT
*RST: UTC

<Year>	integer Required for <code>TimeBasis = UTC</code> Range: 1980 to 9999
<Month>	integer Required for <code>TimeBasis = UTC</code> Range: 1 to 12
<Day>	integer Required for <code>TimeBasis = UTC</code> Range: 1 to 31
<Hour>	integer Required for <code>TimeBasis = UTC</code> Range: 0 to 23
<Minutes>	integer Required for <code>TimeBasis = UTC</code> Range: 0 to 59
<Seconds>	float Required for <code>TimeBasis = UTC</code> Range: 0 to 59.999 Increment: 0.001
<WeekNumber>	integer Required for <code>TimeBasis = GPS GST BDT</code> Range: 0 to 529947
<TimeOfWeek>	float Required for <code>TimeBasis = GPS GST BDT</code> Range: 0 to 604799.999 Increment: 0.001

Return values:

<Elevation> float

Example: See [Example "Retrieving real-time settings"](#) on page 604.

Usage: Query only

[[:SOURCE<hw>]:BB:GNSS:RT:HDOP?

Queries the horizontal dilution of precision (HDOP) value of the selected satellite constellation.

Return values:

<RealtimeHdop> float
Increment: 0.01
*RST: 0

Example: See [Example"Retrieving real-time settings"](#) on page 604.

Usage: Query only

[[:SOURce<hw>]:BB:GNSS:RT:PDOP?

Queries the position dilution of precision (PDOP) value of the selected satellite constellation.

Return values:

<RealtimePdop> float
 Increment: 0.01
 *RST: 0

Example: See [Example"Retrieving real-time settings"](#) on page 604.

Usage: Query only

[[:SOURce<hw>]:BB:GNSS:RT:VDOP?

Queries the vertical dilution of precision (VDOP) value of the selected satellite constellation.

Return values:

<RealtimeVdop> float
 Increment: 0.01
 *RST: 0

Example: See [Example"Retrieving real-time settings"](#) on page 604.

Usage: Query only

[[:SOURce<hw>]:BB:GNSS:RT:RECEiver[:V<st>]:RLOCation:COORDinates:DECimal? <TimeBasis>, <Year>, <Month>, <Day>, <Hour>, <Minutes>, <Seconds>, <WeekNumber>, <TimeOfWeek>

Queries the coordinates of the receiver location in decimal format for the selected moment of time. The required query parameters depend on the selected timebase.

Query parameters:

<TimeBasis> select
 *RST: UTC
 <Year> integer
 Range: 1980 to 9999
 <Month> integer
 Range: 1 to 12
 <Day> integer
 Range: 1 to 31

<Hour>	integer	Range: 0 to 23
<Minutes>	integer	Range: 0 to 59
<Seconds>	float	Range: 0 to 59.999 Increment: 0.001
<WeekNumber>	integer	Range: 0 to 529947
<TimeOfWeek>	float	Range: 0 to 604799.999 Increment: 0.001

Return values:

<Longitude>	float	Range: -180 to 180 Increment: 1E-7 *RST: 0
<Latitude>	float	Range: -90 to 90 Increment: 1E-7 *RST: 0
<Altitude>	float	Range: -10E3 to 50E6 Increment: 0.01 *RST: 0

Example: See [Example"Retrieving real-time settings"](#) on page 604.

Usage: Query only

**[[:SOURCE<hw>]:BB:GNSS:RT:RECEIVER[:V<st>]:RLOCATION:COORDINATES:DMS?
<TimeBasis>, <Year>, <Month>, <Day>, <Hour>, <Minutes>, <Seconds>,
<WeekNumber>, <TimeOfWeek>**

Queries the coordinates of the receiver location in DMS format for the selected moment of time. The required query parameters depend on the selected timebase.

Query parameters:

<TimeBasis>	select	*RST: UTC
<Year>	integer	Range: 1980 to 9999
<Month>	integer	Range: 1 to 12

<Day>	integer	
	Range:	1 to 31
<Hour>	integer	
	Range:	0 to 23
<Minutes>	integer	
	Range:	0 to 59
<Seconds>	float	
	Range:	0 to 59.999
	Increment:	0.001
<WeekNumber>	integer	
	Range:	0 to 529947
<TimeOfWeek>	float	
	Range:	0 to 604799.999
	Increment:	0.001
Return values:		
<LongitudeDeg>	integer	
	Range:	0 to 180
	*RST:	0
<LongitudeMin>	integer	
	Range:	0 to 59
	*RST:	0
<LongitudeSec>	float	
	Range:	0 to 59.999
	Increment:	1E-4
	*RST:	0
<LongitudeDir>	select	
	*RST:	EAST
<LatitudeDeg>	integer	
	Range:	0 to 90
	*RST:	0
<LatitudeMin>	integer	
	Range:	0 to 59
	*RST:	0
<LatitudeSec>	float	
	Range:	0 to 59.999
	Increment:	1E-4
	*RST:	0
<LatitudeDir>	select	
	*RST:	NORT

<Altitude> float
 Range: -10E3 to 50E6
 Increment: 0.01
 *RST: 0

Example: See [Example "Retrieving real-time settings"](#) on page 604.

Usage: Query only

[:SOURCE<hw>]:BB:GNSS:RT:RATTitude? <TimeBasis>, <Year>, <Month>, <Day>, <Hour>, <Minutes>, <Seconds>, <WeekNumber>, <TimeOfWeek>

Queries the receiver attitude parameters yaw, pitch, roll in degrees for the selected moment of time.

Query parameters:

<TimeBasis> UTC | GPS | GST | GLO | BDT
 *RST: UTC

<Year> integer
 Required for TimeBasis = UTC
 Range: 1980 to 9999

<Month> integer
 Required for TimeBasis = UTC
 Range: 1 to 12

<Day> integer
 Required for TimeBasis = UTC
 Range: 1 to 31

<Hour> integer
 Required for TimeBasis = UTC
 Range: 0 to 23

<Minutes> integer
 Required for TimeBasis = UTC
 Range: 0 to 59

<Seconds> float
 Required for TimeBasis = UTC
 Range: 0 to 59.999
 Increment: 0.001

<WeekNumber> integer
 Required for TimeBasis = GPS | GST | BDT
 Range: 0 to 529947

<TimeOfWeek> float
 Required for `TimeBasis = GPS|GST|BDT`
 Range: 0 to 604799.999
 Increment: 0.001

Return values:

<Yaw> float
 Range: -3.14 to 3.14
 Increment: 0.01
 *RST: 0

<Pitch> float
 Range: -3.14 to 3.14
 Increment: 0.01
 *RST: 0

<Roll> float
 Range: -3.14 to 3.14
 Increment: 0.01
 *RST: 0

Example: See [Example"Configuring the simulation monitor"](#) on page 604.

Usage: Query only

[:SOURCE<hw>]:BB:GNSS:RT:RPVT? <TimeBasis>, <Year>, <Month>, <Day>, <Hour>, <Minutes>, <Seconds>, <WeekNumber>, <TimeOfWeek>

Queries the velocity and the coordinates of the receiver location in decimal format for the selected moment of time.

The required query parameters depend on the selected timebase.

Query parameters:

<TimeBasis> UTC | GPS | GST | GLO | BDT
 *RST: UTC

<Year> integer
 Required for `TimeBasis = UTC`
 Range: 1980 to 9999

<Month> integer
 Required for `TimeBasis = UTC`
 Range: 1 to 12

<Day> integer
 Required for `TimeBasis = UTC`
 Range: 1 to 31

<Hour>	integer Required for <code>TimeBasis = UTC</code> Range: 0 to 23
<Minutes>	integer Required for <code>TimeBasis = UTC</code> Range: 0 to 59
<Seconds>	float Required for <code>TimeBasis = UTC</code> Range: 0 to 59.999 Increment: 0.001
<WeekNumber>	integer Required for <code>TimeBasis = GPS GST BDT</code> Range: 0 to 529947
<TimeOfWeek>	float Required for <code>TimeBasis = GPS GST BDT</code> Range: 0 to 604799.999 Increment: 0.001

Return values:

<Longitude>	float Range: -180 to 180 Increment: 1E-13 *RST: 0
<Latitude>	float Range: -90 to 90 Increment: 1E-13 *RST: 0
<Altitude>	float Range: -10E3 to 50E6 Increment: 1E-6 *RST: 0
<Velocity>	float Range: 0 to 1000 Increment: 1E-6 *RST: 0 Default unit: m/s

Example: See [Example"Configuring the simulation monitor"](#) on page 604.

```
[ :SOURce<hw>]:BB:GNSS:RT:RECEiver[:V<st>]:RVELOCITY? <TimeBasis>,
    <Year>, <Month>, <Day>, <Hour>, <Minutes>, <Seconds>, <WeekNumber>,
    <TimeOfWeek>
```

Queries the velocity of the receiver location for the selected moment of time.

The required query parameters depend on the selected timebase.

Query parameters:

<TimeBasis>	select	
	*RST:	UTC
<Year>	integer	
	Range:	1980 to 9999
<Month>	integer	
	Range:	1 to 12
<Day>	integer	
	Range:	1 to 31
<Hour>	integer	
	Range:	0 to 23
<Minutes>	integer	
	Range:	0 to 59
<Seconds>	float	
	Range:	0 to 59.999
	Increment:	0.001
<WeekNumber>	integer	
	Range:	0 to 529947
<TimeOfWeek>	float	
	Range:	0 to 604799.999
	Increment:	0.001

Return values:

<Velocity>	float	
	Range:	0 to 1000
	Increment:	1E-6
	*RST:	0

Example: See [Example"Retrieving real-time settings"](#) on page 604.

Usage: Query only

22.19 Data logging commands

Example: To enable data logging

The following is a simple example on how to use the settings.

```
:SOURCE1:BB:GNSS:TMODe NAV
:SOURCE1:BB:GNSS:SYSTem:GALileo:STATe 1
:SOURCE1:BB:GNSS:TIME:START:TBASis GPS
:SOURCE1:BB:GNSS:NAVigation:SIMulation:WNUMBER?
// 1780
:SOURCE1:BB:GNSS:NAVigation:SIMulation:TOWeek?
// 280816

:SOURCE1:BB:GNSS:RECeiver:V1:POSition MOV
:SOURCE1:BB:GNSS:RECeiver:V1:LOCation:WAYPoints:FILE "Melbourne_Car_Motion.xtd"
:SOURCE1:BB:GNSS:SV:SELECTION:GPS:MAX 4
:SOURCE1:BB:GNSS:SV:SELECTION:GALileo:MAX 4

:SOURCE1:BB:GNSS:LOGGing:MODE OFFL
:SOURCE1:BB:GNSS:LOGGing:OFFLine:TOFFset 0
:SOURCE1:BB:GNSS:LOGGing:OFFLine:DURation 60
:SOURCE1:BB:GNSS:LOGGing:DESTination:FILE:DIRectory "/var/user/my_logs"
:SOURCE1:BB:GNSS:LOGGing:DESTination:FILE:TAPPend:STATe 1

:SOURCE1:BB:GNSS:LOGGing:CATegory:UMOTion:STATe 1
:SOURCE1:BB:GNSS:LOGGing:CATegory:UMOTion:STEP R10S
:SOURCE1:BB:GNSS:LOGGing:CATegory:UMOTion:FORMat?
// CSV
:SOURCE1:BB:GNSS:LOGGing:CATegory:UMOTion:CSV:SElect:ALL
:SOURCE1:BB:GNSS:LOGGing:CATegory:SATellite:STATe 1
:SOURCE1:BB:GNSS:LOGGing:CATegory:SATellite:STEP R10S
:SOURCE1:BB:GNSS:LOGGing:CATegory:SATellite:SElect:ALL
:SOURCE1:BB:GNSS:LOGGing:CATegory:SATellite:FORMat?
// CSV
:SOURCE1:BB:GNSS:STATe 1

:SOURCE1:BB:GPS:LOGGing:OFFLine:GENerate
:SOURCE1:BB:GPS:LOGGing:OFFLine:PROGress?
```

Commands:

[:SOURCE1:BB:GNSS:LOGGing:MODE.....	626
[:SOURCE1:BB:GNSS:LOGGing:OFFLine:ABORT.....	626
[:SOURCE1:BB:GNSS:LOGGing:OFFLine:GENerate.....	626
[:SOURCE1:BB:GNSS:LOGGing:RT:STATe.....	626
[:SOURCE1:BB:GNSS:LOGGing:OFFLine:TOFFset.....	626
[:SOURCE1:BB:GNSS:LOGGing:OFFLine:DURation.....	627
[:SOURCE1:BB:GNSS:LOGGing:OFFLine:PROGress?.....	627
[:SOURCE1:BB:GNSS:LOGGing:DESTination:FILE:DIRectory.....	627

[SOURce<hw>]:BB:GNSS:LOGGing:DESTination:FILE:TAPPend[:STATe].....	627
[SOURce<hw>]:BB:GNSS:LOGGing:CATegory:SATellite:FORMat?.....	628
[SOURce<hw>]:BB:GNSS:LOGGing:CATegory:UMOTion:FORMat?.....	628
[SOURce<hw>]:BB:GNSS:LOGGing:CATegory:UMOTion:STATe.....	628
[SOURce<hw>]:BB:GNSS:LOGGing:CATegory:SATellite:STATe.....	628
[SOURce<hw>]:BB:GNSS:LOGGing:CATegory:UMOTion:STEP.....	628
[SOURce<hw>]:BB:GNSS:LOGGing:CATegory:SATellite:STEP.....	628
[SOURce<hw>]:BB:GNSS:LOGGing:CATegory:UMOTion[:CSV]:SElect:ALL.....	628
[SOURce<hw>]:BB:GNSS:LOGGing:CATegory:UMOTion[:CSV]:SElect:NONE.....	628
[SOURce<hw>]:BB:GNSS:LOGGing:CATegory:SATellite:SElect:NONE.....	628
[SOURce<hw>]:BB:GNSS:LOGGing:CATegory:SATellite:SElect:ALL.....	628
[SOURce<hw>]:BB:GNSS:LOGGing:CATegory:SATellite:ACCEleration:ECEF.....	629
[SOURce<hw>]:BB:GNSS:LOGGing:CATegory:SATellite:AZIMuth.....	629
[SOURce<hw>]:BB:GNSS:LOGGing:CATegory:SATellite:CBias.....	629
[SOURce<hw>]:BB:GNSS:LOGGing:CATegory:SATellite:CRANge.....	629
[SOURce<hw>]:BB:GNSS:LOGGing:CATegory:SATellite:DSHift.....	629
[SOURce<hw>]:BB:GNSS:LOGGing:CATegory:SATellite:ELEVation.....	629
[SOURce<hw>]:BB:GNSS:LOGGing:CATegory:SATellite:IDELay.....	629
[SOURce<hw>]:BB:GNSS:LOGGing:CATegory:SATellite:POSition:ECEF.....	629
[SOURce<hw>]:BB:GNSS:LOGGing:CATegory:SATellite:PRANge.....	629
[SOURce<hw>]:BB:GNSS:LOGGing:CATegory:SATellite:PRRate.....	629
[SOURce<hw>]:BB:GNSS:LOGGing:CATegory:SATellite:PRBias.....	629
[SOURce<hw>]:BB:GNSS:LOGGing:CATegory:SATellite:PRBRate.....	629
[SOURce<hw>]:BB:GNSS:LOGGing:CATegory:SATellite:RANge.....	629
[SOURce<hw>]:BB:GNSS:LOGGing:CATegory:SATellite:RRATE.....	629
[SOURce<hw>]:BB:GNSS:LOGGing:CATegory:SATellite:SLEVel.....	629
[SOURce<hw>]:BB:GNSS:LOGGing:CATegory:SATellite:TDELay.....	629
[SOURce<hw>]:BB:GNSS:LOGGing:CATegory:SATellite:VELocity:ECEF.....	629
[SOURce<hw>]:BB:GNSS:LOGGing:CATegory:UMOTion[:CSV]:ACCEleration:ECEF.....	629
[SOURce<hw>]:BB:GNSS:LOGGing:CATegory:UMOTion[:CSV]:ATTitude.....	629
[SOURce<hw>]:BB:GNSS:LOGGing:CATegory:UMOTion[:CSV]:ATTitude:ACCEleration.....	629
[SOURce<hw>]:BB:GNSS:LOGGing:CATegory:UMOTion[:CSV]:ATTitude:JERK.....	629
[SOURce<hw>]:BB:GNSS:LOGGing:CATegory:UMOTion[:CSV]:ATTitude:RATE.....	629
[SOURce<hw>]:BB:GNSS:LOGGing:CATegory:UMOTion[:CSV]:GDOP.....	629
[SOURce<hw>]:BB:GNSS:LOGGing:CATegory:UMOTion[:CSV]:GSPeed.....	629
[SOURce<hw>]:BB:GNSS:LOGGing:CATegory:UMOTion[:CSV]:AOFFset.....	629
[SOURce<hw>]:BB:GNSS:LOGGing:CATegory:UMOTion[:CSV]:HDOP.....	629
[SOURce<hw>]:BB:GNSS:LOGGing:CATegory:UMOTion[:CSV]:JERK:ECEF.....	629
[SOURce<hw>]:BB:GNSS:LOGGing:CATegory:UMOTion[:CSV]:SVS.....	629
[SOURce<hw>]:BB:GNSS:LOGGing:CATegory:UMOTion[:CSV]:PDOP.....	629
[SOURce<hw>]:BB:GNSS:LOGGing:CATegory:UMOTion[:CSV]:POSition:ECEF.....	629
[SOURce<hw>]:BB:GNSS:LOGGing:CATegory:UMOTion[:CSV]:POSition:ENU.....	629
[SOURce<hw>]:BB:GNSS:LOGGing:CATegory:UMOTion[:CSV]:POSition:LLA.....	629
[SOURce<hw>]:BB:GNSS:LOGGing:CATegory:UMOTion[:CSV]:TDOP.....	630
[SOURce<hw>]:BB:GNSS:LOGGing:CATegory:UMOTion[:CSV]:VELocity:ECEF.....	630
[SOURce<hw>]:BB:GNSS:LOGGing:CATegory:UMOTion[:CSV]:VELocity:LNED.....	630
[SOURce<hw>]:BB:GNSS:LOGGing:CATegory:UMOTion[:CSV]:VDOP.....	630

[:SOURce<hw>]:BB:GNSS:LOGGing:MODE <Mode>

Sets the logging mode.

Parameters:

<Mode> RT | OFFLine
 RT = real-time
 OFFLine = offline
 *RST: RT

Example: See [Example "To enable data logging"](#) on page 624.

Manual operation: See ["Mode"](#) on page 292

[:SOURce<hw>]:BB:GNSS:LOGGing:OFFLine:ABORt
[:SOURce<hw>]:BB:GNSS:LOGGing:OFFLine:GENerate

Logging files are created and saved. Files with the same name are overwritten.

To stop the generation, send [\[:SOURce<hw>\]:BB:GNSS:LOGGing:OFFLine:ABORt](#).

Example: See [Example "To enable data logging"](#) on page 624.

Usage: Event

Manual operation: See ["Generate"](#) on page 293

[:SOURce<hw>]:BB:GNSS:LOGGing:RT:STATe <Status>

Starts real-time data logging.

Parameters:

<Status> 1 | ON | 0 | OFF
 *RST: 0

Example: SOURce1:BB:GPS:LOGGing:RT:STATe 1

Manual operation: See ["State"](#) on page 292

[:SOURce<hw>]:BB:GNSS:LOGGing:OFFLine:TOFFset <TimeOffset>

Delays the logging start.

Parameters:

<TimeOffset> float
 Range: 0 to 864000
 Increment: 1E-3
 *RST: 0
 Default unit: s

Example: See [Example "To enable data logging"](#) on page 624.

Manual operation: See ["Time Offset"](#) on page 293

[[:SOURce<hw>]:BB:GNSS:LOGGing:OFFLine:DURation <Duration>

Sets the logging duration.

Parameters:

<Duration> float
 Range: 0 to 2073600
 Increment: 0.001
 *RST: 0
 Default unit: s

Example: See [Example "To enable data logging"](#) on page 624.

Manual operation: See ["Duration"](#) on page 293

[[:SOURce<hw>]:BB:GNSS:LOGGing:OFFLine:PROGress?

Queries the progress of the offline data logging generation.

Return values:

<Progress> integer
 Range: 0 to 100
 *RST: 100

Example: See [Example "To enable data logging"](#) on page 624.

Usage: Query only

[[:SOURce<hw>]:BB:GNSS:LOGGing:DESTination:FILE:DIRectory <Directory>

Sets the storage place.

Parameters:

<Directory> string
 File path

Example: See [Example "To enable data logging"](#) on page 624.

Manual operation: See ["Directory"](#) on page 293
 See ["Create New Subdirectory for Each Run"](#) on page 293

**[[:SOURce<hw>]:BB:GNSS:LOGGing:DESTination:FILE:TAPPend[:STATe]
 <Append>**

Adds a timestamp to the filename.

Parameters:

<Append> 1 | ON | 0 | OFF
 *RST: 1

Example: See [Example "To enable data logging"](#) on page 624.

Manual operation: See ["Create New Subdirectory for Each Run"](#) on page 293

```
[ :SOURce<hw>]:BB:GNSS:LOGGing:CATegory:SATellite:FORMat?
[ :SOURce<hw>]:BB:GNSS:LOGGing:CATegory:UMOTion:FORMat?
```

Sets the file format in that the logged data is saved.

Return values:

```
<Format>          CSV
                  *RST:      CSV
```

Example: See [Example "To enable data logging"](#) on page 624.

Usage: Query only

Manual operation: See ["Format"](#) on page 294

```
[ :SOURce<hw>]:BB:GNSS:LOGGing:CATegory:UMOTion:STATe <State>
[ :SOURce<hw>]:BB:GNSS:LOGGing:CATegory:SATellite:STATe <State>
```

Enables the logging of the selected category.

Parameters:

```
<State>          1 | ON | 0 | OFF
                  *RST:      0
```

Example: see [Example "To enable data logging"](#) on page 624.

Manual operation: See ["State"](#) on page 294

```
[ :SOURce<hw>]:BB:GNSS:LOGGing:CATegory:UMOTion:STEP <Resolution>
[ :SOURce<hw>]:BB:GNSS:LOGGing:CATegory:SATellite:STEP <Resolution>
```

Sets the logging step.

Parameters:

```
<Resolution>    R1S | R2S | R5S | R10S | R02S | R04S | R08S
                  *RST:      R1S
```

Example: See [Example "To enable data logging"](#) on page 624.

Manual operation: See ["Log Step /s"](#) on page 294

```
[ :SOURce<hw>]:BB:GNSS:LOGGing:CATegory:UMOTion[:CSV]:SElect:ALL
[ :SOURce<hw>]:BB:GNSS:LOGGing:CATegory:UMOTion[:CSV]:SElect:NONE
[ :SOURce<hw>]:BB:GNSS:LOGGing:CATegory:SATellite:SElect:NONE
[ :SOURce<hw>]:BB:GNSS:LOGGing:CATegory:SATellite:SElect:ALL
```

Enables or disables all of the available SV IDs.

Example: See [Example "To enable data logging"](#) on page 624.

Usage: Event

Manual operation: See ["Logged Satellite Parameters"](#) on page 295

```

[:SOURCE<hw>]:BB:GNSS:LOGGING:CATegory:SATellite:ACCEleration:ECEF
  <State>
[:SOURCE<hw>]:BB:GNSS:LOGGING:CATegory:SATellite:AZIMuth <State>
[:SOURCE<hw>]:BB:GNSS:LOGGING:CATegory:SATellite:CBlas <State>
[:SOURCE<hw>]:BB:GNSS:LOGGING:CATegory:SATellite:CRANge <State>
[:SOURCE<hw>]:BB:GNSS:LOGGING:CATegory:SATellite:DSHift <State>
[:SOURCE<hw>]:BB:GNSS:LOGGING:CATegory:SATellite:ELEVation <State>
[:SOURCE<hw>]:BB:GNSS:LOGGING:CATegory:SATellite:IDELay <State>
[:SOURCE<hw>]:BB:GNSS:LOGGING:CATegory:SATellite:POSition:ECEF <State>
[:SOURCE<hw>]:BB:GNSS:LOGGING:CATegory:SATellite:PRANge <State>
[:SOURCE<hw>]:BB:GNSS:LOGGING:CATegory:SATellite:PRRate <State>
[:SOURCE<hw>]:BB:GNSS:LOGGING:CATegory:SATellite:PRBias <State>
[:SOURCE<hw>]:BB:GNSS:LOGGING:CATegory:SATellite:PRBRate <State>
[:SOURCE<hw>]:BB:GNSS:LOGGING:CATegory:SATellite:RANge <State>
[:SOURCE<hw>]:BB:GNSS:LOGGING:CATegory:SATellite:RRATE <State>
[:SOURCE<hw>]:BB:GNSS:LOGGING:CATegory:SATellite:SLEVel <State>
[:SOURCE<hw>]:BB:GNSS:LOGGING:CATegory:SATellite:TDELay <State>
[:SOURCE<hw>]:BB:GNSS:LOGGING:CATegory:SATellite:VELocity:ECEF <State>

```

Enables the parameter for logging.

Parameters:

```

<State>          1 | ON | 0 | OFF
                  *RST:      1

```

Example: See [Example "To enable data logging"](#) on page 624.

```

[:SOURCE<hw>]:BB:GNSS:LOGGING:CATegory:UMOTion[:CSV]:ACCEleration:
  ECEF <State>
[:SOURCE<hw>]:BB:GNSS:LOGGING:CATegory:UMOTion[:CSV]:ATTitude <State>
[:SOURCE<hw>]:BB:GNSS:LOGGING:CATegory:UMOTion[:CSV]:ATTitude:
  ACCEleration <State>
[:SOURCE<hw>]:BB:GNSS:LOGGING:CATegory:UMOTion[:CSV]:ATTitude:JERK
  <State>
[:SOURCE<hw>]:BB:GNSS:LOGGING:CATegory:UMOTion[:CSV]:ATTitude:RATE
  <State>
[:SOURCE<hw>]:BB:GNSS:LOGGING:CATegory:UMOTion[:CSV]:GDOP <State>
[:SOURCE<hw>]:BB:GNSS:LOGGING:CATegory:UMOTion[:CSV]:GSPeed <State>
[:SOURCE<hw>]:BB:GNSS:LOGGING:CATegory:UMOTion[:CSV]:AOFFset <State>
[:SOURCE<hw>]:BB:GNSS:LOGGING:CATegory:UMOTion[:CSV]:HDOP <State>
[:SOURCE<hw>]:BB:GNSS:LOGGING:CATegory:UMOTion[:CSV]:JERK:ECEF
  <State>
[:SOURCE<hw>]:BB:GNSS:LOGGING:CATegory:UMOTion[:CSV]:SVS <State>
[:SOURCE<hw>]:BB:GNSS:LOGGING:CATegory:UMOTion[:CSV]:PDOP <State>
[:SOURCE<hw>]:BB:GNSS:LOGGING:CATegory:UMOTion[:CSV]:POSition:ECEF
  <State>
[:SOURCE<hw>]:BB:GNSS:LOGGING:CATegory:UMOTion[:CSV]:POSition:ENU
  <State>
[:SOURCE<hw>]:BB:GNSS:LOGGING:CATegory:UMOTion[:CSV]:POSition:LLA
  <State>

```

```
[:SOURce<hw>]:BB:GNSS:LOGGing:CATegory:UMOTion[:CSV]:TDOP <State>
[:SOURce<hw>]:BB:GNSS:LOGGing:CATegory:UMOTion[:CSV]:VELocity:ECEF
<State>
[:SOURce<hw>]:BB:GNSS:LOGGing:CATegory:UMOTion[:CSV]:VELocity:LNED
<State>
[:SOURce<hw>]:BB:GNSS:LOGGing:CATegory:UMOTion[:CSV]:VDOP <State>
```

Enables the parameter for logging.

Parameters:

```
<State>          1 | ON | 0 | OFF
*RST:           1
```

Example: See [Example "To enable data logging"](#) on page 624.

22.20 Advanced mode commands

Option: R&S SMW-B9

Example: Multi-band GNSS signal

```
*****
// Select advanced mode.
*****
SCONfiguration:MODE GNSS
SCONfiguration:APPLY

*****
// Select GNSS system, RF bands and signals.
*****
SOURce1:BB:GNSS:SYSTEM:GPS:STATE 1
SOURce1:BB:GNSS:L1Band:STATE 1
SOURce1:BB:GNSS:L2Band:STATE 1
SOURce1:BB:GNSS:L5Band:STATE 1
SOURce1:BB:GNSS:SYSTEM:GPS:SIGNAL:L1Band:CA:STATE 1
SOURce1:BB:GNSS:SYSTEM:GPS:SIGNAL:L1Band:P:STATE 1
SOURce1:BB:GNSS:SYSTEM:GPS:SIGNAL:L2Band:L2C:STATE 1
SOURce1:BB:GNSS:SYSTEM:GPS:SIGNAL:L5Band:L5S:STATE 1
*****
// Specify the number of receivers.
*****
SOURce1:BB:GNSS:VEHICLE:COUNT 1
*****
// Specify each output stream: vehicle, number of antennas, number of basebands,
// e.g. route L1, L2 and L5 signals to the RF and BBMM 1 outputs.
*****
SOURce1:BB:GNSS:STReam1:RFBand L1
SOURce1:BB:GNSS:STReam2:RFBand L2
SOURce1:BB:GNSS:STReam3:RFBand L5
SOURce1:BB:GNSS:STReam1:VEHICLE 1
```

```

SOURCE1:BB:GNSS:STReam2:VEHicle 1
SOURCE1:BB:GNSS:STReam3:VEHicle 1
SOURCE1:BB:GNSS:STReam1:ANTenna A1
SOURCE1:BB:GNSS:STReam2:ANTenna A1
SOURCE1:BB:GNSS:STReam3:ANTenna A1
SOURCE1:BB:GNSS:STReam1:BB:COUNT 2
SOURCE1:BB:GNSS:STReam2:BB:COUNT 1
SOURCE1:BB:GNSS:STReam3:BB:COUNT 1
SOURCE1:BB:GNSS:STReam1:OUTPut:RF1:STAtE 1
SOURCE1:BB:GNSS:STReam2:OUTPut:RF2:STAtE 1
SOURCE1:BB:GNSS:STReam3:OUTPut:BBM1:STAtE 1
SOURCE1:BB:GNSS:STReam1:OUTPut? RFA
SOURCE1:BB:GNSS:STReam2:OUTPut? RFB
SOURCE1:BB:GNSS:STReam3:OUTPut? NONE
*****
// Query separately max. number of channels and allocated basebands per stream.
*****
SOURCE1:BB:GNSS:STReam1:BB:CHANnels:ALlocated? "72"
SOURCE1:BB:GNSS:STReam2:BB:CHANnels:ALlocated? "24"
SOURCE1:BB:GNSS:STReam3:BB:CHANnels:ALlocated? "24"
SOURCE1:BB:GNSS:STReam1:BB:LIST? "A,C"
SOURCE1:BB:GNSS:STReam2:BB:LIST? "B"
SOURCE1:BB:GNSS:STReam3:BB:LIST? "D"
*****
// Or query combined allocated basebands and max. number of channels per stream.
*****
SOURCE1:BB:GNSS:STReam1:BB:INFO? "BB A (36 Ch), BB C (36 Ch)"
SOURCE1:BB:GNSS:STReam1:CHANnels:MAX? "72"
SOURCE1:BB:GNSS:STReam2:BB:INFO? "BB B (24 Ch)"
SOURCE1:BB:GNSS:STReam3:BB:INFO? "BB D (24 Ch)"
*****
// Monitor channels per stream.
*****
SOURCE1:BB:GNSS:MONitor1:DISPlay CHANnels
SOURCE1:BB:GNSS:MONitor1:DISPlay:STReam S1
SOURCE1:BB:GNSS:MONitor1:DISPlay:STReam S2
SOURCE1:BB:GNSS:MONitor1:DISPlay:STReam S3

```

Example: Multi-vehicle scenario

```

*****
// Select advanced mode.
*****
SCONfiguration:MODE GNSS
SCONfiguration:APPLY

*****
// Select GNSS system, RF bands and signals.
*****
SOURCE1:BB:GNSS:SYSTem:GPS:STAtE 1
SOURCE1:BB:GNSS:LlBand:STAtE 1

```

```

SOURCE1:BB:GNSS:SYSTEM:GPS:SIGNAL:L1Band:CA:STATE 1
*****
// Enable two receivers and set the reference receiver.
*****
SOURCE1:BB:GNSS:VEHICLE:COUNT 2
SOURCE1:BB:GNSS:SV:SELECTION:REFERENCE:VEHICLE V1
*****
// Specify receivers V1 and V2: Type, number of antennas, antenna pattern, etc.
*****
SOURCE1:BB:GNSS:RECEIVER:V1:POSITION STAT
SOURCE1:BB:GNSS:RECEIVER:V1:ANTENNA:COUNT 2
SOURCE1:BB:GNSS:RECEIVER:V1:A1:BODY:FILE "Car_Medium.body_mask"
SOURCE1:BB:GNSS:RECEIVER:V1:A1:APATTERN:FILE "PatchAntenna.ant_pat"
SOURCE1:BB:GNSS:RECEIVER:V1:A2:BODY:FILE "Car_Medium.body_mask"
SOURCE1:BB:GNSS:RECEIVER:V1:A1:DX 0.9
SOURCE1:BB:GNSS:RECEIVER:V1:A2:DX -0.9
SOURCE1:BB:GNSS:RECEIVER:V2:POSITION MOV
SOURCE1:BB:GNSS:RECEIVER:V2:ANTENNA:COUNT 2
SOURCE1:BB:GNSS:RECEIVER:V2:A1:BODY:FILE "Bus.body_mask"
SOURCE1:BB:GNSS:RECEIVER:V2:A2:BODY:FILE "Bus.body_mask"
SOURCE1:BB:GNSS:RECEIVER:V2:A1:DX 4
SOURCE1:BB:GNSS:RECEIVER:V2:A2:DX -2
*****
// Specify each output stream: vehicle, number of antennas, number of basebands,
// e.g. route the A1 signal of both vehicles V1 and V2 to the RF outputs.
*****
SOURCE1:BB:GNSS:STREAM1:VEHICLE 1
SOURCE1:BB:GNSS:STREAM2:VEHICLE 2
SOURCE1:BB:GNSS:STREAM1:ANTENNA A1
SOURCE1:BB:GNSS:STREAM2:ANTENNA A1
SOURCE1:BB:GNSS:STREAM1:RFBAND L1
SOURCE1:BB:GNSS:STREAM2:RFBAND L1
SOURCE1:BB:GNSS:STREAM1:OUTPUT:RF1:STATE 1
SOURCE1:BB:GNSS:STREAM2:OUTPUT:RF2:STATE 1

```

Example: Multi-antenna receiver

```

*****
// Select advanced mode.
*****
SOURCE1:MODE GNSS
SOURCE1:APPLY

*****
// Select GNSS system, RF bands and signals.
*****
SOURCE1:BB:GNSS:SYSTEM:GPS:STATE 1
SOURCE1:BB:GNSS:L1Band:STATE 1
SOURCE1:BB:GNSS:SYSTEM:GPS:SIGNAL:L1Band:CA:STATE 1
*****
// Specify the receivers, e.g. one receiver with two antennas.

```



```

*****
SOURCE1:BB:GNSS:VEHICLE:COUNT 1
SOURCE1:BB:GNSS:RECEIVER:V1:POSITION MOV
SOURCE1:BB:GNSS:RECEIVER:V1:ANTENNA:COUNT 2
SOURCE1:BB:GNSS:RECEIVER:V1:A1:BODY:FILE "Car_Medium.body_mask"
SOURCE1:BB:GNSS:RECEIVER:V1:A1:APATTERN:FILE "PatchAntenna.ant_pat"
SOURCE1:BB:GNSS:RECEIVER:V1:A2:BODY:FILE "Car_Medium.body_mask"
SOURCE1:BB:GNSS:RECEIVER:V1:A1:DX 0.9
SOURCE1:BB:GNSS:RECEIVER:V1:A2:DX -0.9
*****
// Specify the reference vehicle.
*****
SOURCE1:BB:GNSS:SV:SELECTION:REFERENCE:VEHICLE V1
*****
// Specify each output stream: vehicle, number of antennas, number of basebands,
// e.g. route the A1 and A2 signals to the RF outputs
*****
SOURCE1:BB:GNSS:STREAM1:VEHICLE 1
SOURCE1:BB:GNSS:STREAM2:VEHICLE 1
SOURCE1:BB:GNSS:STREAM1:RFBAND L1
SOURCE1:BB:GNSS:STREAM2:RFBAND L1
SOURCE1:BB:GNSS:STREAM1:ANTENNA A1
SOURCE1:BB:GNSS:STREAM2:ANTENNA A2
SOURCE1:BB:GNSS:STREAM1:OUTPUT:RF1:STATE 1
SOURCE1:BB:GNSS:STREAM2:OUTPUT:RF2:STATE 1

```

Example: Output stream signal routing

```

*****
// Select advanced mode.
*****
SCONFIGURATION:MODE GNSS
SCONFIGURATION:APPLY

*****
// Select GNSS system, RF bands and signals.
*****
SOURCE1:BB:GNSS:SYSTEM:GPS:STATE 1
SOURCE1:BB:GNSS:L1BAND:STATE 1
SOURCE1:BB:GNSS:L2BAND:STATE 1
SOURCE1:BB:GNSS:L5BAND:STATE 1
SOURCE1:BB:GNSS:SYSTEM:GPS:SIGNAL:L1BAND:CA:STATE 1
SOURCE1:BB:GNSS:SYSTEM:GPS:SIGNAL:L2BAND:L2C:STATE 1
SOURCE1:BB:GNSS:SYSTEM:GPS:SIGNAL:L5BAND:L5S:STATE 1
*****
// Specify each output stream: Number of streams, vehicle, number of antennas,
// and number of basebands, for e.g. three RF bands, two receivers.
*****
SOURCE1:BB:GNSS:STREAM1:RFBAND L1
// Verify that L1 band is enabled in stream 1 only.
SOURCE1:BB:GNSS:STREAM1:L1BAND? 1

```

```

SOURCE1:BB:GNSS:STREAm1:L2Band? 0
SOURCE1:BB:GNSS:STREAm1:L5Band? 0
SOURCE1:BB:GNSS:STREAm2:RFBand L2
SOURCE1:BB:GNSS:STREAm3:RFBand L5
SOURCE1:BB:GNSS:STREAm1:VEHicle 1
SOURCE1:BB:GNSS:STREAm2:VEHicle 1
SOURCE1:BB:GNSS:STREAm3:VEHicle 1
SOURCE1:BB:GNSS:STREAm1:ANTenna A1
SOURCE1:BB:GNSS:STREAm2:ANTenna A1
SOURCE1:BB:GNSS:STREAm3:ANTenna A1
SOURCE1:BB:GNSS:STREAm1:BB:COUNT 2
SOURCE1:BB:GNSS:STREAm2:BB:COUNT 1
SOURCE1:BB:GNSS:STREAm3:BB:COUNT 1
SOURCE1:BB:GNSS:STREAm1:OUTPut:RF1:STATe 1
SOURCE1:BB:GNSS:STREAm2:OUTPut:RF2:STATe 1
SOURCE1:BB:GNSS:STREAm3:OUTPut:BBMM1:STATe 1
*****
// Lock the output stream configuration and disable L5 band.
*****
SOURCE1:BB:GNSS:OSTReams:LOCK 1
SOURCE1:BB:GNSS:L5Band:STATe 0
*****
// Monitor signal generation conflicts in the output stream configuration.
*****
SOURCE1:BB:GNSS:OSTReams:CONFLICT? 1
SOURCE1:BB:GNSS:STREAm1:CONFLICT? 0
SOURCE1:BB:GNSS:STREAm2:CONFLICT? 0
SOURCE1:BB:GNSS:STREAm3:CONFLICT? 1
SOURCE1:BB:GNSS:STREAm3:BB:INFO? "BB D (0 Ch)"
*****
// Redefine the output stream to output connector routing.
*****
SOURCE1:BB:GNSS:OSTReams:OUTPut:RESet
SOURCE1:BB:GNSS:STREAm1:OUTPut:RF2:STATe 1
SOURCE1:BB:GNSS:STREAm2:OUTPut:BBMM2:STATe 1

```

Commands:

[:SOURCE<hw>]:BB:GNSS:OSTReams:CONFLICT?	635
[:SOURCE<hw>]:BB:GNSS:STREAm<st>:CONFLICT?	635
[:SOURCE<hw>]:BB:GNSS:OSTReams:COUNT	635
[:SOURCE<hw>]:BB:GNSS:OSTReams:LOCK	635
[:SOURCE<hw>]:BB:GNSS:OSTReams:OUTPut:RESet	635
[:SOURCE<hw>]:BB:GNSS:STREAm<st>:ANTenna	636
[:SOURCE<hw>]:BB:GNSS:STREAm<st>:BB:COUNT	636
[:SOURCE<hw>]:BB:GNSS:STREAm<st>:BB:INFO?	636
[:SOURCE<hw>]:BB:GNSS:STREAm<st>:BB:LIST?	636
[:SOURCE<hw>]:BB:GNSS:STREAm<st>:BB:CHANnels:ALLocated?	637
[:SOURCE<hw>]:BB:GNSS:STREAm<st>:CHANnels:MAX	637
[:SOURCE<hw>]:BB:GNSS:STREAm<st>:L5Band[:STATe]	637

<code>[:SOURce<hw>]:BB:GNSS:STReam<st>:L2Band[:STATe]</code>	637
<code>[:SOURce<hw>]:BB:GNSS:STReam<st>:L1Band[:STATe]</code>	637
<code>[:SOURce<hw>]:BB:GNSS:STReam<st>:OUTPut:BBMM<ch>:STATe</code>	637
<code>[:SOURce<hw>]:BB:GNSS:STReam<st>:OUTPut</code>	638
<code>[:SOURce<hw>]:BB:GNSS:STReam<st>:OUTPut:RF<ch>:STATe</code>	638
<code>[:SOURce<hw>]:BB:GNSS:STReam<st>:RFBand</code>	638
<code>[:SOURce<hw>]:BB:GNSS:STReam<st>:VEHicle</code>	638
<code>[:SOURce<hw>]:BB:GNSS:SV:SELECTION:REFerence:VEHicle</code>	639
<code>[:SOURce<hw>]:BB:GNSS:VEHicle:COUNT</code>	639

`[:SOURce<hw>]:BB:GNSS:OSTReams:CONFLICT?`
`[:SOURce<hw>]:BB:GNSS:STReam<st>:CONFLICT?`

Indicates stream-specific and general signal generation conflicts in the GNSS output streams configuration.

Return values:

<ConflictStatus> 1 | ON | 0 | OFF
 *RST: 0

Usage: Query only

Manual operation: See ["Conflict"](#) on page 288

`[:SOURce<hw>]:BB:GNSS:OSTReams:COUNT <OutputStreams>`

Sets the number of GNSS streams.

Parameters:

<OutputStreams> 1 | 2 | 3 | 4 | 5 | 6
 Range: 1 to 4
 *RST: 2

Example: See [Example "Multi-antenna receiver"](#) on page 632

Manual operation: See ["Number of GNSS Streams"](#) on page 286

`[:SOURce<hw>]:BB:GNSS:OSTReams:LOCK <LockState>`

Locks the output streams mapping configuration.

Parameters:

<LockState> 1 | ON | 0 | OFF
 *RST: 0

Example: See [Example "Output stream signal routing"](#) on page 633

Manual operation: See ["Lock Output Streams"](#) on page 286

`[:SOURce<hw>]:BB:GNSS:OSTReams:OUTPut:RESet`

Resets the output stream configuration, where all outputs are disabled.

Example: See [Example"Output stream signal routing"](#) on page 633
Usage: Event

[:SOURce<hw>]:BB:GNSS:STReam<st>:ANTenna <Antenna>

Selects the signal of which antenna is carried by which stream.

Parameters:

<Antenna> A1 | A2 | A3 | A4 | A5 | A6
 *RST: A1

Example: See [Example"Multi-antenna receiver"](#) on page 632.

Manual operation: See ["Antenna"](#) on page 287

[:SOURce<hw>]:BB:GNSS:STReam<st>:BB:COUNT <NumbOfBasebands>

Sets the number of basebands used for the GNSS stream.

Parameters:

<NumbOfBasebands>0 | 1 | 2 | 3 | 4 | 5 | 6
 *RST: 1

Example: See [Example"Multi-band GNSS signal"](#) on page 630.

Manual operation: See ["Max. Number of Channels"](#) on page 287

[:SOURce<hw>]:BB:GNSS:STReam<st>:BB:INFO?

Queries allocated baseband sources and number of channels available for each baseband of the used stream.

Return values:

<Status> string

Example: See [Example"Multi-band GNSS signal"](#) on page 630.

Usage: Query only

Manual operation: See ["Active Channels"](#) on page 287

[:SOURce<hw>]:BB:GNSS:STReam<st>:BB:LIST?

Queries the basebands of the stream.

Return values:

<BbStreams> string

Example: See [Example"Multi-band GNSS signal"](#) on page 630.

Usage: Query only

[:SOURCE<hw>]:BB:GNSS:STReam<st>:BB:CHANnels:ALLocated?

Queries the maximum number of channels of the selected GNSS stream.

For details, see [Chapter G, "Channel budget"](#), on page 682.

Return values:

<AllocatedChans> integer
 Range: 0 to 144
 Increment: 1
 *RST: 24

Example: See [Example "Multi-band GNSS signal"](#) on page 630

Usage: Query only

[:SOURCE<hw>]:BB:GNSS:STReam<st>:CHANnels:MAX <MaxChannels>

Sets the maximum number of channels per stream.

See also [Chapter G, "Channel budget"](#), on page 682.

Parameters:

<MaxChannels> integer
 Range: 0 to depends on options
 *RST: 24

Example: See [Example "Multi-band GNSS signal"](#) on page 630.

Manual operation: See ["Channels"](#) on page 44
 See ["Max. Number of Channels"](#) on page 287

[:SOURCE<hw>]:BB:GNSS:STReam<st>:L5Band[:STATE] <State>**[:SOURCE<hw>]:BB:GNSS:STReam<st>:L2Band[:STATE] <State>****[:SOURCE<hw>]:BB:GNSS:STReam<st>:L1Band[:STATE] <State>**

Activates L1, L2 or L5 bands within the GNSS stream.

Use the command, e.g. to specify, which bands are active and inactive per stream. See also [\[:SOURCE<hw>\]:BB:GNSS:STReam<st>:RFBand](#) on page 638.

Parameters:

<State> 1 | ON | 0 | OFF
 *RST: 0

Example: See [Example "Output stream signal routing"](#) on page 633.

[:SOURCE<hw>]:BB:GNSS:STReam<st>:OUTPut:BBMM<ch>:STATE <State>

Sets the output state of the GNSS stream at the BBMM 1/2 output.

Parameters:

<State> 1 | ON | 0 | OFF
 *RST: 0

Example: See [Example"Output stream signal routing"](#) on page 633

[:SOURce<hw>]:BB:GNSS:STReam<st>:OUTPut <Output>

Sets the output connector to that the output GNSS signal is routed.

Parameters:

<Output> RFA | RFB | NONE
*RST: RFA

Example: See [Example"Multi-band GNSS signal"](#) on page 630.

Manual operation: See ["Output"](#) on page 288

[:SOURce<hw>]:BB:GNSS:STReam<st>:OUTPut:RF<ch>:STATe <State>

Sets the output state of the GNSS stream at the RF A/B output.

Parameters:

<State> 1 | ON | 0 | OFF
*RST: 0

Example: See [Example"Output stream signal routing"](#) on page 633

[:SOURce<hw>]:BB:GNSS:STReam<st>:RFBand <RFBand>

Selects the signal of which RF band is carried by which stream.

Parameters:

<RFBand> L1 | L2 | L5
*RST: L1

Example: See [Example"Multi-band GNSS signal"](#) on page 630.

Options: L2/L5 requires e.g. R&S SMW-K98 for GPS

Manual operation: See ["RF Bands"](#) on page 287

[:SOURce<hw>]:BB:GNSS:STReam<st>:VEHicle <Vehicle>

Selects the signal of which vehicle is carried by which stream.

Parameters:

<Vehicle> V1 | V2
*RST: V1

Example: See [Example"Multi-antenna receiver"](#) on page 632.

Manual operation: See ["Vehicle"](#) on page 287

```
[:SOURce<hw>]:BB:GNSS:SV:SElection:REFerence:VEHicle <ReferenceVehicle>
```

Sets the vehicle for that the satellite constellation settings apply.

Parameters:

```
<ReferenceVehicle>  V1 | V2
                    *RST:    V1
```

Example: See [Example "Multi-antenna receiver"](#) on page 632.

Manual operation: See ["Reference Vehicle"](#) on page 285

```
[:SOURce<hw>]:BB:GNSS:VEHicle:COUNT <NumberOfVehicle>
```

Sets the number of simulated vehicles.

Parameters:

```
<NumberOfVehicle>  integer
                    Range:    1 to 2
                    *RST:    1
```

Example: See [Example "Multi-antenna receiver"](#) on page 632.

Manual operation: See ["Number of Vehicles"](#) on page 283

22.21 Trigger commands

Example: Configure and enable triggering

```
SOURce1:BB:GNSS:TRIGger:SEquence SINGLE
SOURce1:BB:GNSS:TRIGger:SLENgth 200

// The first 200 samples of the current waveform are output after
// the next trigger event.
SOURce1:BB:GNSS:TRIGger:SEquence ARETrigger
SOURce1:BB:GNSS:TRIGger:SOURce EGT1
// External trigger signal provided at the USER connector.
SOURce1:BB:GNSS:TRIGger:EXTernal:SYNChronize:OUTPut ON
SOURce1:BB:GNSS:TRIGger:EXTernal:DELay 200
SOURce1:BB:GNSS:TRIGger:EXTernal:INHibit 100

SOURce1:BB:GNSS:TRIGger:SOURce INTB
// The internal trigger signal from the other path is used.
SOURce1:BB:GNSS:TRIGger:OBASeband:DELay 25
SOURce1:BB:GNSS:TRIGger:OBASeband:INHibit 10

SOURce1:BB:GNSS:TRIGger:SEquence AAUTO
SOURce1:BB:GNSS:TRIGger:SOURce INTernal
SOURce1:BB:GNSS:STAT ON
SOURce1:BB:GNSS:TRIGger:EXEC
```

Example: Specifying delay and inhibit values in time units

```

SOURCE1:BB:GNSS:CLOCK 1000000
SOURCE1:BB:GNSS:TRIGGER:SEQUENCE AAUT
SOURCE1:BB:GNSS:TRIGGER:SOURCE EGT1
SOURCE1:BB:GNSS:TRIGGER:DELAY:UNIT SAMP
SOURCE1:BB:GNSS:TRIGGER:EXTERNAL:DELAY 100
SOURCE1:BB:GNSS:TRIGGER:EXTERNAL:RDELAY?
// Response: 100

SOURCE1:BB:GNSS:TRIGGER:DELAY:UNIT TIME
SOURCE1:BB:GNSS:TRIGGER:EXTERNAL:TDELAY 0.00001
SOURCE1:BB:GNSS:TRIGGER:EXTERNAL:RDELAY?
// Response: 0.00001

SOURCE1:BB:GNSS:TRIGGER:DELAY:UNIT SAMP
SOURCE1:BB:GNSS:TRIGGER:EXTERNAL:DELAY 10

```

Commands

[:SOURCE<hw>]:BB:GNSS[:TRIGGER]:SEQUENCE	640
[:SOURCE<hw>]:BB:GNSS:TRIGGER:SOURCE	640
[:SOURCE<hw>]:BB:GNSS:TRIGGER:RMODE?	641
[:SOURCE<hw>]:BB:GNSS:TRIGGER:TIME:DATE	641
[:SOURCE<hw>]:BB:GNSS:TRIGGER:TIME:TIME	642
[:SOURCE<hw>]:BB:GNSS:TRIGGER:TIME[:STATE]	642
[:SOURCE<hw>]:BB:GNSS:TRIGGER:SLNGTH	643
[:SOURCE<hw>]:BB:GNSS:TRIGGER:EXECUTE	643
[:SOURCE<hw>]:BB:GNSS:TRIGGER:ARM:EXECUTE	643
[:SOURCE<hw>]:BB:GNSS:TRIGGER:EXTERNAL:SYNCHRONIZE:OUTPUT	643
[:SOURCE<hw>]:BB:GNSS:TRIGGER:OBASBAND:DELAY	644
[:SOURCE<hw>]:BB:GNSS:TRIGGER:OBASBAND:INHIBIT	644
[:SOURCE<hw>]:BB:GNSS:TRIGGER[:EXTERNAL]:DELAY	644
[:SOURCE<hw>]:BB:GNSS:TRIGGER[:EXTERNAL]:INHIBIT	645

[:SOURCE<hw>]:BB:GNSS[:TRIGGER]:SEQUENCE <Sequence>

Selects the trigger mode.

Parameters:

<Sequence> AUTO | RETRigger | AAUTo | ARETrigger | SINGLE
 *RST: AUTO

Example: See [Chapter 22.22, "Marker commands"](#), on page 645.

Manual operation: See ["Mode"](#) on page 338

[:SOURCE<hw>]:BB:GNSS:TRIGGER:SOURCE <Source>

Selects the trigger signal source and determines the way the triggering is executed. Provided are the following trigger sources:

- INTernal: Internal manual triggering of the instrument

- INTA|INTB: Internal triggering by a signal from the other basebands
- External trigger signal via one of the local or global connectors:
 - EGT1|EGT2: External global trigger
 - EGC1|EGC2: External global clock
 - ELTRigger: External local trigger
 - ELCLock: External local clock
- For secondary instruments (SCONfiguration:MULTIinstrument:MODE SEC), triggering via the external baseband synchronization signal of the primary instrument:
SOURCE1:BB:ARB:TRIGGER:SOURCE BBSY
- OBASeband|BEXternal|EXTernal: Setting only
Provided only for backward compatibility with other Rohde & Schwarz signal generators. The R&S SMW200A accepts these values and maps them automatically as follows:
EXTernal = EGT1, BEXternal = EGT2, OBASeband = INTA or INTB
(depending on the current baseband)

Parameters:

<Source> INTB|INTernal|OBASeband|EGT1|EGT2|EGC1|EGC2|ELTRigger|INTA|ELCLock|BEXternal|EXTernal

Example: See [Chapter 22.22, "Marker commands"](#), on page 645.

Manual operation: See ["Source"](#) on page 340

[:SOURCE<hw>] : BB : GNSS : TRIGGER : RMODE ?

Queries the status of waveform output.

Return values:

<RMode> STOP | RUN
*RST: STOP

Example: See [Example "Configure and enable triggering"](#) on page 639.

Usage: Query only

Manual operation: See ["Running/Stopped"](#) on page 339

[:SOURCE<hw>] : BB : GNSS : TRIGGER : TIME : DATE <Year>, <Month>, <Day>

Sets the date for a time-based trigger signal. For trigger modes single or armed auto, you can activate triggering at this date via the following command:

SOURCE<hw>:BB:<DigStd>:TRIGGER:TIME:STATE

<DigStd> is the mnemonic for the digital standard, for example, ARB. Time-based triggering behaves analogously for all digital standards that support this feature.

Parameters:

<Year>	integer	
	Range:	1980 to 9999
<Month>	integer	
	Range:	1 to 12
<Day>	integer	
	Range:	1 to 31

Example: See example "Configure a time-based trigger signal" in the sub-chapter "Trigger Commands" of the chapter "SOURCE:BB:ARB subsystem" in the R&S SMW200A user manual.

Manual operation: See "Trigger Time" on page 340

[:SOURCE<hw>] : BB : GNSS : TRIGGER : TIME : TIME <Hour>, <Minute>, <Second>

Sets the time for a time-based trigger signal. For trigger modes single or armed auto, you can activate triggering at this time via the following command:

SOURCE<hw>:BB:<DigStd>:TRIGGER:TIME:STATE

<DigStd> is the mnemonic for the digital standard, for example, ARB. Time-based triggering behaves analogously for all digital standards that support this feature.

Parameters:

<Hour>	integer	
	Range:	0 to 23
<Minute>	integer	
	Range:	0 to 59
<Second>	integer	
	Range:	0 to 59

Example: See example "Configure a time-based trigger signal" in the sub-chapter "Trigger Commands" of the chapter "SOURCE:BB:ARB subsystem" in the R&S SMW200A user manual.

Manual operation: See "Trigger Time" on page 340

[:SOURCE<hw>] : BB : GNSS : TRIGGER : TIME [: STATE] <State>

Activates time-based triggering with a fixed time reference. If activated, the R&S SMW200A triggers signal generation when its operating system time matches a specified time.

Specify the trigger date and trigger time with the following commands:

SOURCE<hw>:BB:<DigStd>:TRIGGER:TIME:DATE

SOURCE<hw>:BB:<DigStd>:TRIGGER:TIME:TIME

<DigStd> is the mnemonic for the digital standard, for example, ARB. Time-based triggering behaves analogously for all digital standards that support this feature.

Parameters:

<State> 1 | ON | 0 | OFF

Example: See example "Configure a time-based trigger signal" in the sub-chapter "Trigger Commands" of the chapter "SOURce:BB:ARB subsystem" in the R&S SMW200A user manual.

Manual operation: See ["Time Based Trigger"](#) on page 339

[SOURce<hw>]:BB:GNSS:TRIGger:SLENgth <SLength>

Defines the length of the signal sequence to be output in the SINGLE trigger mode.

Parameters:

<SLength> float
 Range: 0.001 to 46.648730700
 Increment: 1E-9
 *RST: 1
 Default unit: s

Example: See [Example"Configure and enable triggering"](#) on page 639.

Manual operation: See ["Signal Duration"](#) on page 339

[SOURce<hw>]:BB:GNSS:TRIGger:EXECute

Executes an internal trigger event.

Example: See [Example"Configure and enable triggering"](#) on page 639.

Usage: Event

Manual operation: See ["Execute Trigger"](#) on page 340

[SOURce<hw>]:BB:GNSS:TRIGger:ARM:EXECute

Stops (arms) waveform output.

Example: See [Example"Configure and enable triggering"](#) on page 639.

Usage: Event

Manual operation: See ["Arm"](#) on page 340

[SOURce<hw>]:BB:GNSS:TRIGger:EXTernal:SYNChronize:OUTPut <Output>

Enables signal output synchronous to the trigger event.

Parameters:

<Output> 1 | ON | 0 | OFF
 *RST: 1

Example: See [Example "Configure and enable triggering"](#) on page 639.

Manual operation: See ["Sync. Output to External Trigger/Sync. Output to Trigger"](#) on page 341

[:SOURce<hw>]:BB:GNSS:TRIGger:OBASeband:DELay <Delay>

Specifies the trigger delay for triggering by the signal from the second path.

Parameters:

<Delay>	float
	Range: 0 to 23.324365344
	Increment: 1E-9
	*RST: 0

Example: See [Chapter 22.21, "Trigger commands"](#), on page 639.

Manual operation: See ["External Delay/Trigger Delay"](#) on page 342

[:SOURce<hw>]:BB:GNSS:TRIGger:OBASeband:INHibit <Inhibit>

For triggering via the other path, specifies the number of samples by which a restart is inhibited.

Parameters:

<Inhibit>	float
	Range: 0 to 0.728886406
	Increment: 1E-9
	*RST: 0

Example: See [Chapter 22.21, "Trigger commands"](#), on page 639.

Manual operation: See ["External Inhibit/Trigger Inhibit"](#) on page 342

[:SOURce<hw>]:BB:GNSS:TRIGger[:EXTernal]:DELay <Delay>

Specifies the trigger delay for external triggering. The value affects all external trigger signals.

Parameters:

<Delay>	float
	Range: 0 to 23.324365344
	Increment: 1E-9
	*RST: 0

Example: See [Chapter 22.21, "Trigger commands"](#), on page 639.

Manual operation: See ["External Delay/Trigger Delay"](#) on page 342

[SOURce<hw>]:BB:GNSS:TRIGger[:EXternal]:INHibit <Inhibit>

Specifies the number of chips by which a restart is to be inhibited following an external trigger event.

Parameters:

<Inhibit>	float
	Range: 0 to 21.47
	Increment: 1E-9
	*RST: 0

Example: See [Chapter 22.21, "Trigger commands"](#), on page 639.

Manual operation: See ["External Inhibit/Trigger Inhibit"](#) on page 342

22.22 Marker commands

Example: Configure and enable marker signals

```
SOURce1:BB:GNSS:TRIGger:OUTPut1:MODE PPS
SOURce1:BB:GNSS:TRIGger:OUTPut1:PULSe:WIDTh 0.000002
// Delay the marker signal by 10 ns from signal generation start.
SOURce1:BB:GNSS:TRIGger:OUTPut1:DELay 0.000000010
SOURce1:BB:GNSS:TRIGger:OUTPut1:MODE PP2S
SOURce1:BB:GNSS:TRIGger:OUTPut1:MODE PPS10
SOURce1:BB:GNSS:TRIGger:OUTPut1:MODE RAT
SOURce1:BB:GNSS:TRIGger:OUTPut1:ONTime 0.000001
SOURce1:BB:GNSS:TRIGger:OUTPut1:OFFTime 0.000001

SOURce1:BB:GNSS:TRIGger:OUTPut1:HPPS:ADELay 20
SOURce1:BB:GNSS:TRIGger:OUTPut1:HPPS:STATE 1
```

Example: Generate a marker signal with fixed frequency

```
// Generate a regular marker signal.
SOURce1:BB:GNSS:TRIGger:OUTPut1:MODE PULS
SOURce1:BB:GNSS:TRIGger:OUTPut1:PULSe:DIVider 2
// Find out the frequency of the marker signal.
SOURce1:BB:GNSS:TRIGger:OUTPut1:PULSe:FREQuency?
// Response in Hz: 511500
// Alternatively define the marker pattern "10".
SOURce1:BB:GNSS:TRIGger:OUTPut1:MODE PATT
SOURce1:BB:GNSS:TRIGger:OUTPut1:PATTern #H2,2
// Route the marker signal to the USER 1 output connector.
SOURce1:INPut:USER1:DIRection OUTP
OUTput1:USER1:SIGnal MARKA1
// The frequency of the marker signal is also 511500 Hz.
```

Commands

<code>[[:SOURce<hw>]:BB:GNSS:TRIGger:OUTPut<ch>:MODE</code>	646
<code>[[:SOURce<hw>]:BB:GNSS:TRIGger:OUTPut<ch>:ONTime</code>	646
<code>[[:SOURce<hw>]:BB:GNSS:TRIGger:OUTPut<ch>:OFFTime</code>	646
<code>[[:SOURce<hw>]:BB:GNSS:TRIGger:OUTPut<ch>:DELAy</code>	646
<code>[[:SOURce<hw>]:BB:GNSS:TRIGger:OUTPut<ch>:HPPS:ADELAy</code>	647
<code>[[:SOURce<hw>]:BB:GNSS:TRIGger:OUTPut<ch>:HPPS:STATe</code>	647
<code>[[:SOURce<hw>]:BB:GNSS:TRIGger:OUTPut<ch>:PATTeRn</code>	647
<code>[[:SOURce<hw>]:BB:GNSS:TRIGger:OUTPut<ch>:PULSe:DIVider</code>	647
<code>[[:SOURce<hw>]:BB:GNSS:TRIGger:OUTPut<ch>:PULSe:FREQuency?</code>	648
<code>[[:SOURce<hw>]:BB:GNSS:TRIGger:OUTPut<ch>:PULSe:WIDTh</code>	648

`[[:SOURce<hw>]:BB:GNSS:TRIGger:OUTPut<ch>:MODE <Mode>`

Defines the signal for the selected marker output.

Parameters:

<Mode> PULSe|PATTeRn|RATio|PPS|PP2S|PPS10
*RST: PPS

Example: See [Example"Configure and enable marker signals"](#) on page 645.

Manual operation: See ["Mode"](#) on page 344

`[[:SOURce<hw>]:BB:GNSS:TRIGger:OUTPut<ch>:ONTime <OnTime>`**`[[:SOURce<hw>]:BB:GNSS:TRIGger:OUTPut<ch>:OFFTime <OffTime>`**

Sets the number of chips during which the marker output is on or off.

Parameters:

<OffTime> float
Range: 0.000000011 to 0.1822215935
Increment: 1E-9
*RST: 1E-6

Example: See [Example"Configure and enable marker signals"](#) on page 645.

Manual operation: See ["Mode"](#) on page 344

`[[:SOURce<hw>]:BB:GNSS:TRIGger:OUTPut<ch>:DELAy <Delay>`

Defines the delay between the signal on the marker outputs and the start of the signals.

Parameters:

<Delay> float
Range: 0 to 0.1822215935
Increment: 1E-9
*RST: 0

Example: See [Example"Configure and enable marker signals"](#) on page 645.

Manual operation: See ["Delay"](#) on page 345

[:SOURce<hw>]:BB:GNSS:TRIGger:OUTPut<ch>:HPPS:ADELay
<AdditionalDelay>

Sets an additional delay for the high-precision PPS marker signal.

Parameters:

<AdditionalDelay> float
Range: 0 to 10E-6
Increment: 1E-12
*RST: 0

Example: See [Example"Configure and enable marker signals"](#) on page 645.

Manual operation: See ["Additional Delay"](#) on page 346

[:SOURce<hw>]:BB:GNSS:TRIGger:OUTPut<ch>:HPPS:STATE
<HighPrecPpsStat>

Enables generation of a high-precision PPS marker signal.

Parameters:

<HighPrecPpsStat> 1 | ON | 0 | OFF
*RST: 0

Example: See [Example"Configure and enable marker signals"](#) on page 645.

Manual operation: See ["Generate High Precision PPS"](#) on page 346

[:SOURce<hw>]:BB:GNSS:TRIGger:OUTPut<ch>:PATTern <Pattern>

Defines the bit pattern used to generate the marker signal.

Parameters:

<Pattern> 64 bits

Example: See [Example"Generate a marker signal with fixed frequency"](#) on page 645.

Manual operation: See ["Mode"](#) on page 344

[:SOURce<hw>]:BB:GNSS:TRIGger:OUTPut<ch>:PULSe:DIVider <Divider>

Sets the divider for pulse marker mode (PULSe).

Parameters:

<Divider> integer
 Range: 2 to 1024
 *RST: 2

Example: See [Example"Generate a marker signal with fixed frequency"](#) on page 645.

Manual operation: See ["Mode"](#) on page 344

[[:SOURce<hw>]:BB:GNSS:TRIGger:OUTPut<ch>:PULSe:FREQuency?

Queries the pulse frequency of the pulsed marker signal. The pulse frequency is derived by dividing the symbol rate by the divider.

Return values:

<Frequency> float

Example: See [Example"Generate a marker signal with fixed frequency"](#) on page 645.

Usage: Query only

Manual operation: See ["Mode"](#) on page 344

[[:SOURce<hw>]:BB:GNSS:TRIGger:OUTPut<ch>:PULSe:WIDTh <Width>

Sets the pulse width for 1PPS, 1PP2S and PPS10 marker mode. The maximum pulse width depends on the marker mode.

Marker mode	1PPS	1PP2S	PPS10
Max. pulse width	1 s	2 s	0.1 s

Parameters:

<Width> float
 Range: 1E-9 to depends on the marker mode
 Increment: 1E-9
 *RST: 1E-6

Example: See [Example"Configure and enable marker signals"](#) on page 645.

Manual operation: See ["Mode"](#) on page 344

22.23 Clock commands

Example: Clock settings

```
SOURce1:BB:GNSS:CLOCK:SOURce ELCL
SOURce1:BB:GNSS:CLOCK:MODE SAMP
CLOCK:INPUt:FREQuency?
```

```
[:SOURce<hw>]:BB:GNSS:CLOCK:SOURce..... 649
[:SOURce<hw>]:BB:GNSS:CLOCK:MODE..... 649
```

[:SOURce<hw>]:BB:GNSS:CLOCK:SOURce <Source>

Selects the clock source:

- **INTernal**: Internal clock reference
- **ELCLock**: External local clock
- **EXTernal** = **ELCLock**: Setting only
Provided for backward compatibility with other Rohde & Schwarz signal generators

Parameters:

```
<Source>          INTernal|ELCLock|EXTernal
*RST:             INTernal
```

Example: See [Chapter 22.23, "Clock commands"](#), on page 649.

Manual operation: See ["Clock Source"](#) on page 347

[:SOURce<hw>]:BB:GNSS:CLOCK:MODE <Mode>

Sets the type of externally supplied clock.

Parameters:

```
<Mode>           CHIP
*RST:            CHIP
```

Example: See [Chapter 22.23, "Clock commands"](#), on page 649.

Manual operation: See ["Clock Mode"](#) on page 347

Annex

A User environment files

The R&S SMW200A supports different file formats that describe a moving receiver. This section focus on:

- [Movement or motion files](#)..... 650
- [Vehicle description files](#)..... 662
- [Antenna pattern and body mask files](#)..... 663

A.1 Movement or motion files

A.1.1 Waypoint file format

A waypoint file is a simple text file (*.txt) that describes a trajectory as a sequence of positions called waypoints. The file contains a resolution (mandatory) in milliseconds that specifies the time between two consecutive waypoints. Also a list of waypoint coordinates (optional), one row per waypoint.

Each waypoint is specified with its longitude [° (decimal format)], latitude [° (decimal format)], altitude [m], see [Example "3GPP performance test Scenario#3 "Melbourne" \(WGS84 geodetic coordinates\)"](#) on page 650.

If the defined resolution is different than the internally used resolution of 10 ms, the waypoint file is resampled and the waypoints linearly interpolated. For more information, see [Chapter A.1.5, "Resampling principle"](#), on page 660.

Example: 3GPP performance test Scenario#3 "Melbourne" (WGS84 geodetic coordinates)

The resolution command at the beginning of the file specifies the time (in ms) between two consecutive waypoints. In this example, it is 50 ms. The value is different than 10 ms; the waypoint file is upsampled, see [Chapter A.1.5, "Resampling principle"](#), on page 660.

```
RESOLUTION: 50
144.966666334601,-37.8166633061788,100.000000009313
144.966662392613,-37.8166632247233,100.000000039116
144.966658453002,-37.8166630889914,100.00000008475
144.966654516955,-37.8166628990241,100.000000149943
144.966650585658,-37.8166626548785,100.000000235625
144.966646660296,-37.8166623566284,100.000000339001
...
etc.
```

See also [Chapter A.1.6, "Calculating the maximum duration of a movement file"](#), on page 661.

Example: Polygonal waypoint file with different resolution

The resolution command at the beginning of the file specifies the time (in ms) between two consecutive waypoints.

In the example below, the resolution is 5 ms. The value is different than 10 ms; the waypoint file is downsampled. Samples representing the **bold** lines in the example below are removed.

```
RESOLUTION: 5
144.966666334601,-37.8166633061788,100.00000009313
144.966443162832,-37.8090165067983,100.056669838727
144.973563207169,-37.8081942570311,100.098318068311
144.982795444975,-37.8090450499587,100.214069998823
144.981604761683,-37.8166623866118,100.135388446972
144.966673889123,-37.8166633333333,100.00000008382
```

Monitor the configured movement in "Simulation Monitor > Display > Map View"; the polygonal shape is lost due to removal of samples.

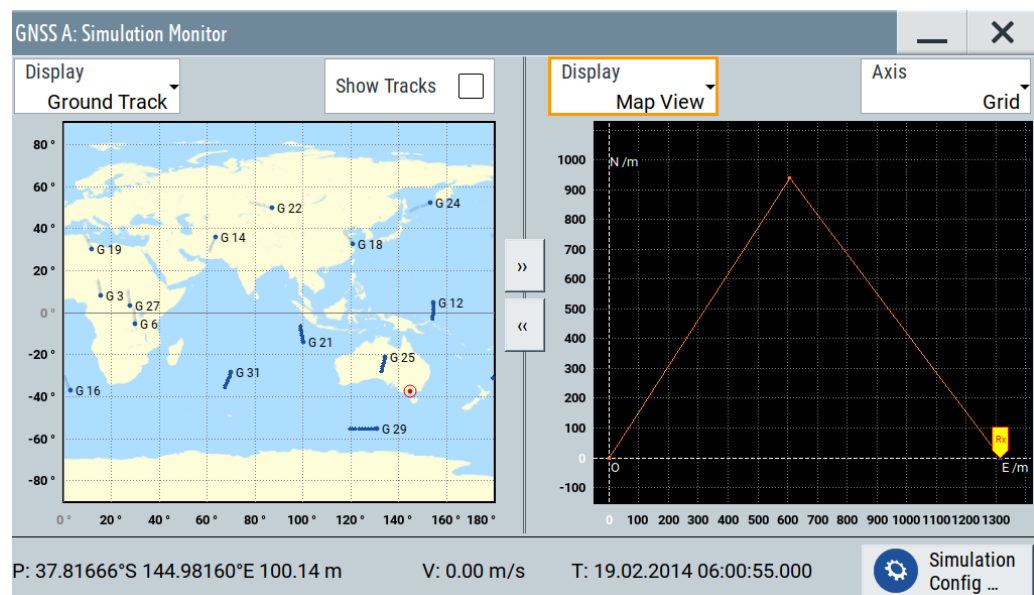

In the example below, the resolution is 10 ms that is the internally used resolution for sampling.

```
RESOLUTION: 10
144.966666334601,-37.8166633061788,100.00000009313
144.966443162832,-37.8090165067983,100.056669838727
144.973563207169,-37.8081942570311,100.098318068311
144.982795444975,-37.8090450499587,100.214069998823
144.981604761683,-37.8166623866118,100.135388446972
144.966673889123,-37.8166633333333,100.00000008382
```

Monitor the configured movement in "Simulation Monitor > Display > Map View"; the polygonal movement is simulated.

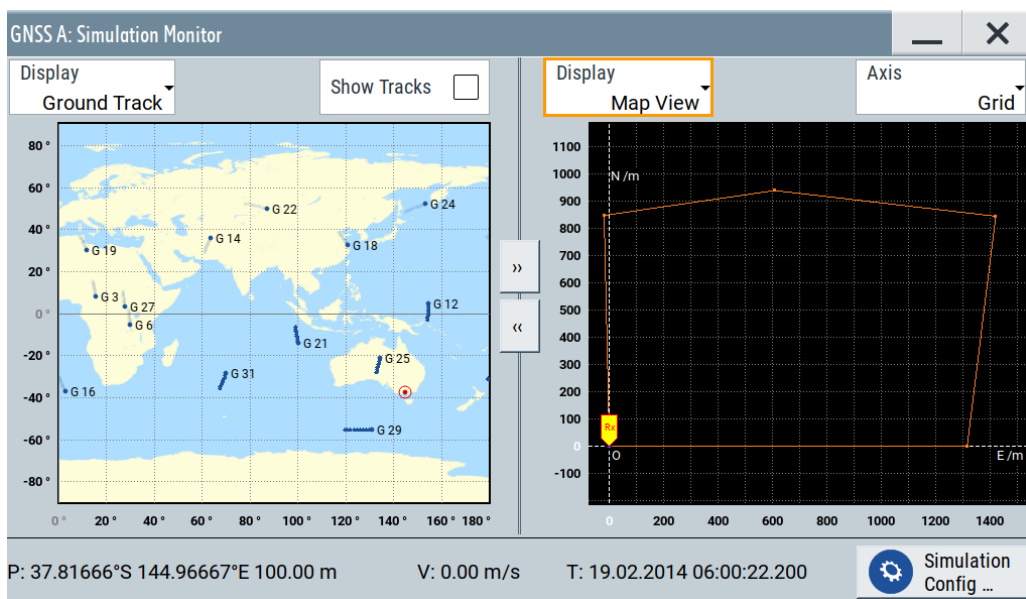

In the example below, the resolution is 50 ms. The value is different than 10 ms; the waypoint file is upsampled, see [Chapter A.1.5, "Resampling principle"](#), on page 660.

```

RESOLUTION: 50
144.966666334601,-37.8166633061788,100.000000009313
144.966443162832,-37.8090165067983,100.056669838727
144.973563207169,-37.8081942570311,100.098318068311
144.982795444975,-37.8090450499587,100.214069998823
144.981604761683,-37.8166623866118,100.135388446972
144.966673889123,-37.8166633333333,100.000000008382
    
```

Monitor the configured movement in "Simulation Monitor > Display > Map View"; samples are added within the polygonal shape of the movement. Four dots between each of the five corner dots of the polygon indicate the added samples.

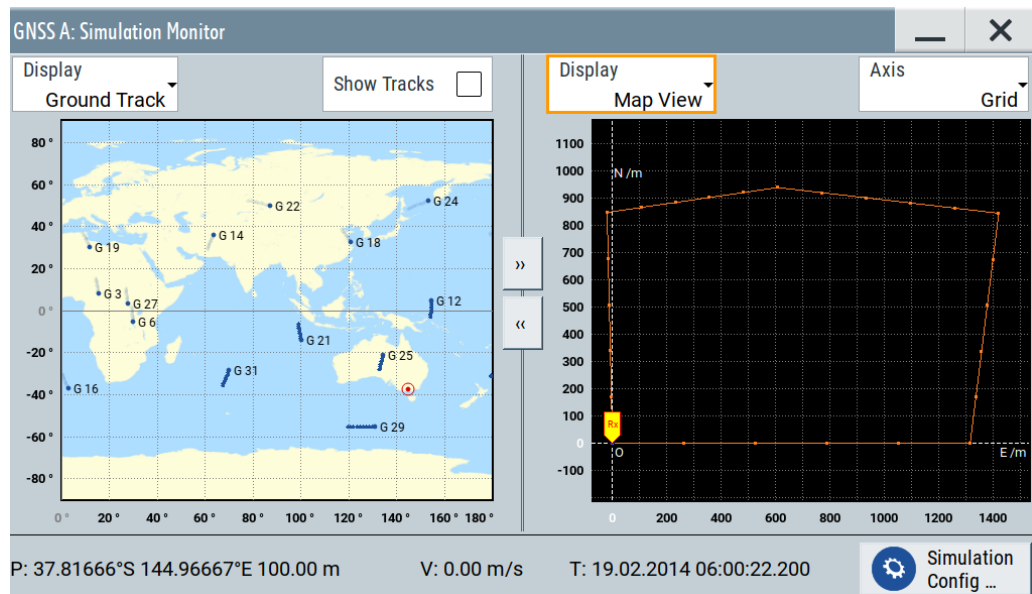

A.1.2 Vector trajectory file format

In the vector trajectory file format, motion is defined in an east North plane which is tangent to earth at the specified reference point. The curvature of the Earth is not considered in the interpretation of the U_p (U) coordinate elements when moving east or north.

The vector trajectory file format is suitable for description of city motion where the curvature of the earth is negligible. This file format is not intended for long-distance simulations where the curvature of the earth is significant.

This file format uses a script containing the commands defined in the following table:

Command	Description
REFERENCE: Lon, Lat, Alt	Specifies the reference point of the East, North and Up (ENU) Cartesian coordinate system. The REFERENCE is specified in ECEF coordinates (Longitude / deg, Latitude / deg, Altitude / m).
START: E ,N, U, Velocity	Start location is the initial "current location" in the ENU Cartesian coordinate of center REFERENCE. East, North and Up (ENU) coordinates are then provided. The last argument is the start velocity (m/s).
ARC: E, N, Angle	Specifies a 2-Dimensional ARC (East / m, North / m) with the first two arguments representing the center of the ARC (m) in the Cartesian basis. The last argument specifies the angle in degrees (deg) of the ARC starting the "current location". Angle sign is significant because it indicates positive direction (counterclockwise) or negative direction (clockwise). The end edge of the arc represents the new "current location". Velocity does not change when using an ARC command.

Command	Description
LINE: ΔE, ΔN, Acceleration	<p>Specifies a 2-dimensional line from the current location or first edge (Current loc E, Current loc N) to the next location or second edge (Current loc E + ΔE, Current loc N + ΔN) (East / m, North / m, Up / m).</p> <p>The argument <code>Acceleration</code> specifies a constant acceleration/deceleration, where <code>Acceleration = 0</code> indicates constant velocity. Unit for acceleration is (m/s²).</p> <p>The second edge is used as the current location for the next command. The speed at this second edge is also used as the start speed for the next command.</p>
LINE3D: ΔE, ΔN, ΔU, Acceleration	<p>Describes a 3-dimensional straight line in ENU coordinates, where the first edge is described as (E, N, U) and the second edge as (E + ΔE, N + ΔN, U + ΔU) (East / m, North / m, Up / m).</p> <p>The argument <code>Acceleration</code> specifies a constant acceleration/deceleration, where <code>Acceleration = 0</code> indicates constant velocity. Unit for acceleration is (m/s²).</p> <p>***** MOVEMENT FILE *****</p> <p>RESOLUTION: 10</p> <p>REFERENCE: 0,0,0</p> <p>START: 0, 0, 10000, 20</p> <p>LINE3D: 0, 0, -10000, 0</p>
STAY: Time	Stay at the current location for <code>Time</code> period (ms).

Example: Example of a waypoint file

This example explains a waypoint file in the second format for the case of the 3GPP performance test Scenario#3 "Melbourne", as described in [TS 34.108](#) and [TS 34.171](#).

The GPS signals simulate the GPS-receiver moving on a rectangular trajectory of 940m by 1440m with rounded corners defined in [Table A-1](#) and [Figure A-1](#).

The initial reference is first defined followed by acceleration to final speed of 100 km/h in 250 m. The UE then maintains the speed for 400 m. The speed then decreases to 25 km/h in 250 m. The UE then turn 90 degrees with turning radius of 20 m at 25 km/h. The speed increases to 100 km/h in 250 m.

The sequence is repeated to complete the rectangle.

Table A-1: Trajectory parameters for moving scenario and periodic update performance test case

Parameter	Distance (m)	Speed (km/h)
$l_{11}, l_{15}, l_{21}, l_{25}$	20	25
$l_{12}, l_{14}, l_{22}, l_{24}$	250	25 to 100 and 100 to 25
l_{13}	400	100
l_{23}	900	100

```
LINE: 250, 0, -1.44675925925925925926
ARC: 1400, 920, -90
LINE: 0, -250, 1.44675925925925925926
LINE: 0, -400, 0
LINE: 0, -250, -1.44675925925925925926
ARC: 1400, 20, -90
LINE: -250, 0, 1.44675925925925925926
LINE: -900, 0, 0
LINE: -250, 0, -1.44675925925925925926
%% End of Trajectory description.
```

A.1.3 NMEA files

The NMEA movement information (receiver-fix location) extracted from a standard NMEA file can be used as a source for the generation of the movement file of interest.

Refer to [Chapter C, "NMEA scenarios"](#), on page 667 for detailed description of the NMEA file format.

A.1.4 Trajectory description files

Option: R&S SMW-K108

The trajectory description files use the file extension *.xtd. See [Example"<position-only> waypoint format with automatic linear time stamp"](#) on page 659 for a simple example of the file format.

The [Table A-2](#) describes the used tags and parameters.

Table A-2: Format of *.xtd file

Container	Tag name	Parameter	Description
<general>	<property>	<waypointformat>	<p>Defines the format of the waypoint data.</p> <p>The possible values are:</p> <ul style="list-style-type: none"> • "positiononly" Only waypoint data • "position_attitude" Waypoint and attitude data • "position_velocitymagnitude" Waypoints and velocity magnitude information per point • "position_velocitymagnitude_attitude" Waypoints, velocity magnitude and attitude data • "position_velocityvector" Waypoints and velocity vector per location • "position_velocityvector_attitude" Waypoints, velocity vector and attitude per point <p>Proper readout of the three formats <code><property waypointformat="*_attitude"></code> requires option R&S SMW-K108. If you load *.xtd files without this option, the simulation discards the attitude values from the file and uses the default values with constant attitude behavior.</p> <p>Smoothing is only possible with <code><property waypointformat="positiononly"></code> and NMEA, waypoints and *.kml.</p> <p>The description of the waypoints has to follow the selected format.</p> <p>For example, the vector <code><waypointvector data="0.05,144.966662392613,-37.8166632247233,100.00000039116"/></code> with <code><property waypointformat="positiononly"/></code> and <code><datavectorhastimestamp="yes"></code> comprises four values.</p>
		<datavectorhastimestamp>	<p>Determines the way the time stamp (elapsed time after simulation start) is defined.</p> <ul style="list-style-type: none"> • With <code><datavectorhastimestamp="yes"></code>, the parameter <code>time</code> is mandatory. We recommend to set a time stamp of 0.0 (<code>time="0"</code>). The time stamp of a waypoint is retrieved from the <code><waypointvector data></code>, as the first data vector parameter. If time stamps do not start with 0.0, the simulation takes the first time stamp as reference time and shift all following timestamps accordingly. That means the simulation assumes that the first time stamps correspond to time 0.0. • With <code><datavectorhastimestamp="no"></code>, setting the parameter <code>time</code> leads to errors during read-out: The time stamp is internally calculated based on the following rule: <ul style="list-style-type: none"> – The time stamp of first waypoint is $T_1 = 0$ – The time stamp of the waypoint_N is $T_N = (N-1) * \text{timeresolution}$
		<coordsystem>	<p>Defines the coordinate system used by the definition of the <code><waypointvector data></code>.</p> <p>Possible values: "enu", "cart ecef", "geod wgs84" or "geod pz90"</p>
		<timeresolution>	<p>If <code><datavectorhastimestamp="no"></code>, applies implicitly time stamps to waypoints. Otherwise, the time stamp is retrieved automatically, see <code><datavectorhastimestamp></code>.</p>

Container	Tag name	Parameter	Description
		<enurefpoint>	Defines the coordinates of the reference waypoint in ECEF format: Longitude (deg), latitude (deg), altitude (m).
		<endbehaviour>	Determines the behavior of the moving object at the end of the trajectory. Possible values: "jump", "return", "stop"
		<attitudeunit>	Defines the unit ("rad" or "deg") the attitude is expressed in
		<noofway-points>	Number of the used waypoints vectors. Use the parameter to minimize the size of the waypoint without actually deleting the waypoints
		<attitudecontinuous>	If <attitudecontinuous="no">, the attitude angles to be read are bounded by 2π . The <attitudecontinuous="yes"> means that they are not bounded.
<waypoints>			Description of the trajectory as a list of waypoint vectors.
	<waypointvector>	<data>	Coordinates of the waypoint in the format selected by <coordsystem> <ul style="list-style-type: none"> [time,]longitude,latitude,altitude (geod wgs84) [time,]X,Y,Z (cart ecef) [time,]EAST,NORTH,UPPER (enu) <p>If <datavectorhastimestamp>="yes", setting the time is mandatory.</p> <p>If <datavectorhastimestamp>="no", setting the time leads to errors during read-out.</p> <p>Depending on the <property waypointformat>, more information can be provided. The following is a list of the information appended to the coordinates of the waypoint mentioned above.</p> <ul style="list-style-type: none"> <property waypointformat="positiononly"> No additional information <property waypointformat="position_attitude"> yaw/heading,pitch/elevation,roll/bank, e.g. [time,]longitude,latitude,altitude,yaw,pitch,roll The vehicle attitude (yaw, pitch and roll) parameters are configured relative to the local horizon <property waypointformat="position_velocitymagnitude"> vel, e.g. [time,]X,Y,Z,vel <property waypointformat="position_velocitymagnitude_attitude"> vel,yaw/heading,pitch/elevation,roll/bank, e.g. [time,]EAST,NORTH,UPPER,vel,yaw,pitch,roll <property waypointformat="position_velocityvector"> Velocity vector Vx,Vy,Vz, e.g. [time,]X,Y,Z,Vx,Vy,Vz <property waypointformat="position_velocityvector_attitude"> Vx,Vy,Vz,yaw/heading,pitch/elevation,roll/bank, e.g. [time,]longitude,latitude,altitude,Vx,Vy,Vz,yaw,pitch,roll. <p>Note: If the waypoints are in geoid wgs84, the velocity vector is assumed in Cartesian ECEF coordinate system.</p>

Waypoint data only files

The following examples emphasize on waypoint files defined with <property waypointformat="positiononly"> format. Also the time stamp principle is illustrated in two different configurations.

The examples can be easily extended to waypoint file formats also specifying attitude and/or velocity data as in [Table A-2](#).

Example: <positiononly> waypoint format with automatic linear time stamp

The <waypointvector data> vector has three parameters, because of the tag <property datavectorhastimestamp="no">. If you also define a fourth value, e.g. time, the waypoint data is read out erroneously.

The time stamps T_x are derived from the tag <property timeresolution="0.05">. The distribution of the time stamps is linear:

$$T_1 = 0, T_2 = (2-1)*0.05 = 0.05, \text{ and so on, } T_{12} = (12-1)*0.05 = 0.55$$

```
<trajectory>
  <general>
    <property waypointformat="positiononly"/>
    <property datavectorhastimestamp="no"/>
    <property coordsystem="enu"/>
    <property timeresolution="0.05"/>
    <property enurefpoint="54.0,10.0,12"/>
    <property endbehaviour="return"/>
    <property noofwaypoints="12"/>
  </general>
  <waypoints>
    <waypointvector data="0,0,0"/>
    <waypointvector data="0,1,0"/>
    <waypointvector data="0,2,0"/>
    <waypointvector data="0,3,0"/>
    <waypointvector data="0,4,0"/>
    <waypointvector data="0,5,0"/>
    <waypointvector data="0,6,0"/>
    <waypointvector data="0,7,0"/>
    <waypointvector data="0,8,0"/>
    <waypointvector data="0,9,0"/>
    <waypointvector data="0,10,0"/>
    <waypointvector data="0,11,0"/>
  </waypoints>
</trajectory>
```

Example: <positiononly> waypoint format with manual non-linear time stamp

The <waypointvector data> vector has four parameters, because of the tag <property datavectorhastimestamp="yes">.

The time stamps T_x are retrieved from the first value in the <waypointvector data> vector. You can set the time stamps individually and define a non-linear distribution:

$$T_1 = 0, T_2 = 0.0081, \text{ and so on, } T_{12} = 0.953.$$

```
<trajectory>
  <general>
```

```

    <property waypointformat="positiononly"/>
    <property datavectorhastimestamp="yes"/>
    <property coordsystem="cart ecef"/>
    <property endbehaviour="jump"/>
    <property attitudeunit="rad"/>
    <property attitudecontinuous="yes"/>
  </general>
  <waypoints>
    <waypointvector data="0.0000, 4178032.9245, 856266.1330, 4727289.0482"/>
    <waypointvector data="0.0081, 4178032.1214, 856270.0516, 4727289.0482"/>
    <waypointvector data="0.0323, 4178031.3183, 856273.9701, 4727289.0482"/>
    <waypointvector data="0.0727, 4178030.5153, 856277.8887, 4727289.0482"/>
    <waypointvector data="0.1290, 4178029.7122, 856281.8072, 4727289.0482"/>
    <waypointvector data="0.2011, 4178028.9091, 856285.7258, 4727289.0482"/>
    <waypointvector data="0.2889, 4178028.1060, 856289.6443, 4727289.0482"/>
    <waypointvector data="0.3921, 4178027.3030, 856293.5629, 4727289.0482"/>
    <waypointvector data="0.5105, 4178026.4999, 856297.4814, 4727289.0482"/>
    <waypointvector data="0.6436, 4178025.6968, 856301.4000, 4727289.0482"/>
    <waypointvector data="0.7913, 4178024.8937, 856305.3186, 4727289.0482"/>
    <waypointvector data="0.9530, 4178024.0906, 856309.2371, 4727289.0482"/>
  </waypoints>
</trajectory>

```

A.1.5 Resampling principle

The resampling principle is common to all movement or motion files. To explain the principle, we use the simple waypoint file text format described in [Chapter A.1.1, "Waypoint file format"](#), on page 650.

The 3GPP performance test Scenario#3 file "Melbourne" uses a resolution of 50 ms.

This resolution is different than the internally used resolution of 10 ms. The waypoint file is resampled (in this case upsampled) and the waypoints linearly interpolated. Four samples are inserted between any two consecutive waypoints so that the sampling rate of 100 Hz (10ms) is achieved.

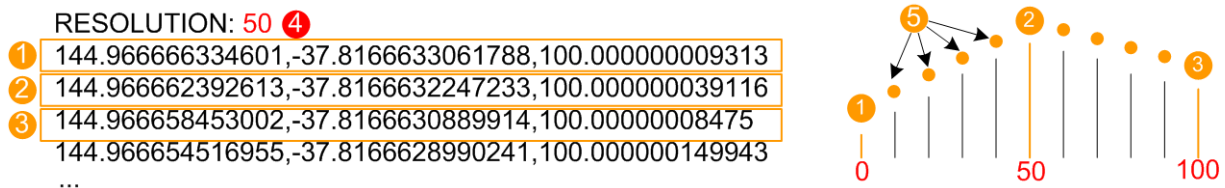

Figure A-2: Principle of waypoint file upsampling (extract of a waypoint file shown)

- 1, 2, 3 = Coordinates of the first three waypoints in the file
- 4 = Resolution
- 5 = Inserted waypoints

If a resolution of 5 ms is used in the same waypoint file, this file is downsampled. Each second waypoint is discarded. This case is illustrated on [Figure A-3](#).

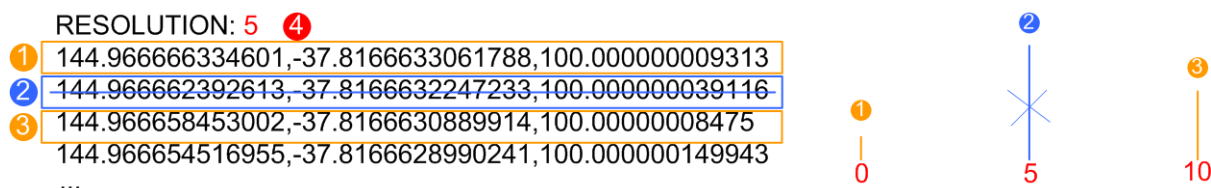

Figure A-3: Principle of waypoint file downsampling (extract of a waypoint file shown)

- 1, 2, 3 = Coordinates of the first three waypoints in the file
 2 = Second waypoint removed
 4 = Resolution

The described resampling principle applies also for resolutions that are not multiple of 10 ms.

For information on the impact of the used resolution on the number of possible waypoints, see [Chapter A.1.6, "Calculating the maximum duration of a movement file"](#), on page 661.

A.1.6 Calculating the maximum duration of a movement file

The R&S SMW200A loads the movement and the motion files in the RAM memory. Hence, it is the available RAM memory that limits the duration of a simulated movement.

If a movement is described for example as a waypoint file, its duration is the product of the used resolution and the number of waypoints. Thus, the maximum number of waypoints in a waypoint file depends on the used resolution.

For a given available RAM memory, the maximum time duration t_{\max} a waypoint file can have, is calculated as:

$t_{\max} [\text{ms}] = (\text{RAM}_{\text{Size}} [\text{bytes}] / 6 \cdot 8 [\text{bytes}]) \cdot 10 [\text{ms}]$, where:

- The RAM_{Size} is the available RAM memory size, e.g. 1 Gbyte;
- 10 ms is the internal resolution
- 6*8 bytes are required to save one resampled waypoint;
Waypoints values are defined in double-precision floating point format (doubles) and a resampled waypoint requires 6 doubles with 8 bytes each.



A warning message indicates the following situations:

- The time duration of the loaded waypoint file exceeds the maximum allowed value
- The RAM memory is insufficient to process the file

Example:

If a waypoint file contains 4 waypoints and uses a resolution of 50 ms, then:

- $\#Waypoints * Resolution_{WaypointFile} = t_{WaypointFile}$, i.e. the waypoint file is $4 * 50 = 200$ ms long.
- The file is resampled to the internal resolution of 10 ms (i.e. sampling rate of 100 Hz) and the resulting number of samples is:
 $\#Samples = t_{WaypointFile} [ms] / Resolution_{Internal} [ms] = 200 / 10 = 20$
- Storing these 20 samples requires a memory of $\#Samples * 6 * 8 [bytes] = 20 * 48 = 960$ bytes.

A.2 Vehicle description files

Use the vehicle description files for smoothening. These files have the file extension *.xvd. The following is a simple example of the file format.

```
<vehicle>
  <info name="Car"/>
  <limits>
    <property maxspeed="100.0"/>
    <property maxacceleration="0.6"/>
    <property maxacceleration_lateral="0.6"/>
    <property maxjerk="15"/>
    <property maxjerk_lateral="15"/>
    <property proximity="0"/>
  </limits>
</vehicle>
```

The [Table A-3](#) describes the used tags and parameters.

Table A-3: Format of *.xvd file

Container	Tag name	Parameter	Description
<info>	<name>		Vehicle name
	<limits>		
<limits>	<property>	<maxspeed>	Maximum speed (m/s)
		<maxacceleration>	Maximum tangential acceleration (m/s ²)
		<maxacceleration_lateral>	Maximum radial acceleration (m/s ²) due to centrifugal force
		<maxjerk>	Maximum tangential Jerk (m/s ³)
		<maxjerk_lateral>	Maximum radial Jerk (m/s ³)
		<proximity>	Specifies the maximum allowed deviation from the original waypoints (m)

A.3 Antenna pattern and body mask files

Option: R&S SMW-K108

Three files describe an antenna: the body mask file `*.body_mask`, the antenna pattern `*.ant_pat` file and the phase response `*.phase` file.

The `*.ant_pat` file describes the power response matrix of each antenna. The instrument retrieves the phase response matrix from the `*.phase` file. If the required `*.phase` file does not exist, a zero-phase response is assumed. Antenna pattern and phase files must have the same filename and must be saved in the same directory. These files have the same content but different data section `<data>` (see [Table A-4](#)).

The following are two examples of the file format: an extract of the description of an antenna pattern with three antennas and description of an antenna with four sectors.

Example: Antenna pattern with three antennas

The following is a file content extract from the predefined file `Space_Vehicle_3_antennas.body_mask`.

```
<?xml version="1.0" encoding="ISO-8859-1"?>
<antenna_pattern>
  <antenna_descr count="3" use_same_pattern="no">
    <antenna id="1" RollAxis_X_offset="0" PitchAxis_Y_offset=" 0.0000"
      YawAxis_Z_offset=" 0.2000" Yaw_offset="0" Pitch_offset="0"
      Roll_offset="0" />
    <antenna id="2" RollAxis_X_offset="0" PitchAxis_Y_offset="-0.1414"
      YawAxis_Z_offset="-0.1414" Yaw_offset="0" Pitch_offset="0"
      Roll_offset="120"/>
    <antenna id="3" RollAxis_X_offset="0" PitchAxis_Y_offset=" 0.1414"
      YawAxis_Z_offset="-0.1414" Yaw_offset="0" Pitch_offset="0"
      Roll_offset="240" />
  </antenna_descr>
  <az_res> 1.00000000e+000 </az_res>
  <elev_res> 1.00000000e+000 </elev_res>
  <data>
    -179.5,-178.5,-177.5,-176.5,-175.5,-174.5,-173.5,-172.5,-171.5,-170.5,-169.5,-168.5,
    -167.5,-166.5,-165.5,-164.5,-163.5,-162.5,-161.5,-160.5,-159.5,-158.5,-157.5,-156.5,
    -155.5,-154.5,-153.5,-152.5,-151.5,-150.5,-149.5,-148.5,-147.5,-146.5,-145.5,-144.5,
    -143.5,-142.5,-141.5,-140.5,-139.5,-138.5,-137.5,-136.5,-135.5,-134.5,-133.5,-132.5,
    ...
  </data>
</antenna_pattern>
```

Example: Antenna with four sectors

The following is a file describing an antenna with four sectors.

```
<?xml version="1.0" encoding="ISO-8859-1"?>
<antenna_pattern>
  <antenna_descr count="1" use_same_pattern="no">
```

Antenna pattern and body mask files

```

<antenna id="1" YawAxis_Z_offset="0" PitchAxis_Y_offset="0"
      RollAxis_X_offset="0" Yaw_offset="0" Pitch_offset="90"
      Roll_offset="0" />
</antenna_descr>
<az_res> 90.00000000e+000 </az_res>
<elev_res> 90.00000000e+000 </elev_res>
<data>
      -135.0,-45.0,45.0,135,45.0,0.0,3.0,6.0,9.0,-45.0,0.0,3.0,6.0,9.0
</data>
</antenna_pattern>

```

The [Table A-4](#) describes the used tags and parameters.

Table A-4: Format of *.body_mask, *.ant_pat and *.phase files

Container	Tag name	Parameter	Description
<antenna_pattern>			Defines antenna pattern file
<antenna_descr>			Contains the descriptions of the antennas
		<count>	Number of antenna patterns. Value range = 1 to 4.
		<use_same_pattern>	Specify whether the same data section is used for all the antennas or not. <ul style="list-style-type: none"> "yes": the data section is used for all antennas "no": the data section is augmented with the data of all antennas consecutively
	<antenna>		Descriptions of the individual antenna
		<id>	Antenna identification number
		<YawAxis_Z_offset> <PitchAxis_Y_offset> <RollAxis_X_offset>	Position shift of the antenna along the X/Y/Z axis relative to the center of gravity of the body Value in meters
		<Yaw_offset> <Pitch_offset> <Roll_offset>	Angular shift of the antenna along the X/Y/Z axis of the body Value in degrees
<az_res>			Resolution of the columns in the data section Value in degrees integer divider of 360

Antenna pattern and body mask files

Container	Tag name	Parameter	Description
<elev_res>			Resolution of the rows in the data section Value in degrees integer divider of 180
<data>			<p>The file has to contain for every pattern:</p> <ul style="list-style-type: none"> • [1 + 360/<az_res>] columns • [1 + 180/<elev_res>] rows <p>Title column and row are disregarded</p> <p>If the <use_same_pattern="yes"> only one pattern is sufficient, otherwise the other patterns must be appended after each other inside this section</p> <p>If the data represents the power response of the antenna (*.ant_pat file), the power loss values are in dB (between 0 and 40)</p> <p>If the data represents the phase response of the antenna (*.phase file), the phase values are in degrees</p>

B RINEX files

The RINEX file format consists of three ASCII file types: observation data file, navigation message file and meteorological data file. The navigation RINEX files provide the ephemeris information of all visible satellites at a control station or a commercial receiver.

Each file type consists of a header section and a data section. The header section contains global information for the entire file and is placed at the beginning of the file. The format of the data records of the RINEX navigation message files can contain navigation messages of more than one satellite system (GPS, GLONASS, Galileo, etc.).

Navigation files

The GNSS firmware of the R&S SMW200A can import and generate RINEX navigation files. For supported file formats and extensions per GNSS system, see [Table B-1](#).

Table B-1: File format and file extension per GNSS

Format	GPS	Galileo	BeiDou	GLONASS	QZSS	NavIC
RINEX 2.x	*.<xx>n	-	-	*.<xx>g	-	-
RINEX 3.x	*.rnx	*.rnx	*.rnx	*.rnx	*.rnx	*.rnx

Where <xx> indicates for the year of the recording. For example, the extensions .12n indicates a GPS ephemeris file, recorded in 2012.

Specification and download sources

Find latest information on the RINEX file format and download sources for RINEX navigation files, for example, on the following websites:

- RINEX file format specifications all versions:
<https://files.igs.org/pub/data/format>
- RINEX file format specification version 3.04:
<https://files.igs.org/pub/data/format/rinex304.pdf>
- RINEX navigation files (registration required):
<https://cddis.nasa.gov/archive/gnss/data/daily/>

C NMEA scenarios

The National Marine Electronic Association (NMEA) is a broadcasting standard supported by all navigation receivers. The NMEA files comprise information about common parameters related to the satellite constellation, navigation parameters, time, receiver location and dynamics. The [Table C-1](#) defines the starting acronym for a NMEA command of a specific navigation standard. In the moment this firmware is released, the Galileo NMEA acronym has not been defined yet.

Table C-1: Overview of the starting acronyms for the NMEA command

ID	Meaning
AG	Autopilot - General
AP	Autopilot - Magnetic
CC	Computer - Programmed Calculator (outdated)
CD	Communications - Digital Selective Calling (DSC)
CM	Computer - Memory Data (outdated)
CS	Communications - Satellite
CT	Communications - Radio-Telephone (MF/HF)
CV	Communications - Radio-Telephone (VHF)
CX	Communications - Scanning Receiver
DE	DECCA Navigation
DF	Direction Finder
EP	Emergency Position Indicating Beacon (EPIRB)
ER	Engine Room Monitoring Systems
GP	Global Positioning System (GPS)
GL	GLONASS
HC	Heading - Magnetic Compass
HE	Heading - North Seeking Gyro
HN	Heading - Non North Seeking Gyro
II	Integrated Instrumentation
IN	Integrated Navigation
LA	Loran A
LC	Loran C
MP	Microwave Positioning System (outdated)
OM	OMEGA Navigation System

Example of NMEA File

```
$GPVTG,,T,,M,0.000,N,0.000,K,A*23
$GPGGA,215810.00,3540.00066,N,13944.99611,E,1,04,1.61,6.8,M,39.4,M,,*5E
$GPGSA,A,3,06,09,04,10,,,,,,,,,2.47,1.61,1.87*01
$GPGSV,4,1,14,29,48,312,,26,47,312,,06,35,302,47,09,18,238,47*71
$GPGSV,4,2,14,27,47,312,,13,50,118,,04,72,181,47,30,48,312,*76
$GPGSV,4,3,14,14,39,070,,10,12,050,47,31,48,312,,07,64,349,*72
$GPGSV,4,4,14,25,47,312,,28,48,312,*7E
$GPGLL,3540.00066,N,13944.99611,E,215810.00,A,A*69
$GPZDA,215810.00,28,04,2023,00,00*64
$GPRMC,215811.00,A,3540.00066,N,13944.99611,E,0.000,,280423,,,*A*7E
```

D QZSS navigation message scheduling

The table on [Figure D-1](#) shows the structure of the QZSS navigation message, as it is implemented in the R&S SMW200A.

#	Time	Subframe 4			Subframe 5		
		Content	Data ID	SVID		Data ID	SVID
1	00:00:00	1 Almanac	11	1	1 Almanac	00	1
2	00:00:30	Health of QZSS	11	51	1 Almanac	00	2
3	00:01:00	IONO	11	56	1 Almanac	00	3
4	00:01:30	1 Almanac	00	25	1 Almanac	00	4
5	00:02:00	IONO	11	56	IONO	00	56
6	00:02:30	1 Almanac	11	2	1 Almanac	00	5
7	00:03:00	Health of QZSS	11	51	1 Almanac	00	6
8	00:03:30	IONO	11	56	1 Almanac	00	7
9	00:04:00	1 Almanac	00	26	1 Almanac	00	8
10	00:04:30	NMCT of GPS	11	52	NMCT QZSS and GPS	11	53
11	00:05:00	1 Almanac	11	3	1 Almanac	00	9
12	00:05:30	Health of QZSS	11	51	1 Almanac	00	10
13	00:06:00	1 Almanac	00	27	1 Almanac	00	11
14	00:06:30	1 Almanac	00	28	1 Almanac	00	12
15	00:07:00	Health of GPS	11	49	Health of GPS	11	50
16	00:07:30	1 Almanac	11	1	1 Almanac	00	13
17	00:08:00	Health of QZSS	11	51	1 Almanac	00	14
18	00:08:30	IONO	11	56	1 Almanac	00	15
19	00:09:00	1 Almanac	00	29	1 Almanac	00	16
20	00:09:30	IONO	11	56	IONO	00	56
21	00:10:00	1 Almanac	11	2	1 Almanac	00	17
22	00:10:30	Health of QZSS	11	51	1 Almanac	00	18
23	00:11:00	IONO	11	56	1 Almanac	00	19
24	00:11:30	Health of GPS	00	51	1 Almanac	00	20
25	00:12:00	NMCT of GPS	11	52	NMCT QZSS and GPS	11	53
26	00:12:30	1 Almanac	11	3	1 Almanac	00	21
27	00:13:00	Health of QZSS	11	51	1 Almanac	00	22
28	00:13:30	1 Almanac	00	31	1 Almanac	00	23
29	00:14:00	1 Almanac	00	32	1 Almanac	00	24
30	00:14:30	Health of GPS	11	49	Health of GPS	11	50

Figure D-1: QZSS navigation message structure



The QZSS navigation message structure used in R&S SMW200A deliberately deviates from the QZSS navigation message scheduling published on the Jaxa web page:

http://qz-vision.jaxa.jp/USE/is-qzss/pattern/pattern_L1CA_N_e.html

The reason for this deviation is that the R&S SMW200A can simulate the signal of up to three QZSS satellites, while the published information applies for the only one available QZSS satellite.

E Predefined GNSS scenarios

If equipped with the GNSS system options, the R&S SMW200A also supports test scenarios for assisted GNSS (A-GNSS) protocol and conformance test cases.

How to: "[To use predefined scenarios](#)" on page 29

The following chapters provide an overview on the 3GPP technical specifications (TS) documents and the related A-GNSS scenario. Also it provides a summary of all test scenarios that are offered on the R&S SMW200A.

Example: Understanding the name of a R&S SMW200A test scenario

The filename of the R&S SMW200A test scenario relates directly to the 3GPP technical specifications (TS) document, the subclause, the test case and the subtest case. The table [Table E-1](#) states the different name elements to illustrate the relation between R&S SMW200A test scenario and the corresponding 3GPP test case.

Table E-1: R&S SMW200A test scenario and 3GPP test case

Name element	R&S SMW200A test scenario name	3GPP test case name
-	"3GPP TS 37.571-1: S7 Performance 5 ST1"	3GPP TS 37.571-1 subclause 7: A-GPS Performance scenario 5, Subtest 1
Organization	3GPP	3GPP
Technical specification	TS 37.571-1	TS 37.571-1
Subclause	S7	Subclause 7
Test case	Performance 5	A-GPS Performance scenario 5
Subtest case	ST1	Subtest 1

The support of the assisted GNSS with the test scenario is provided by the installation of the corresponding GNSS system option.

- [3GPP TS and assisted GNSS](#).....670
- [Assisted GNSS test scenarios](#)..... 671
- [Assisted GNSS 2020 test scenarios](#)..... 676
- [Real constellations reference scenarios](#)..... 680
- [Galileo OSNMA scenarios](#)..... 680

E.1 3GPP TS and assisted GNSS

The 3GPP TS documents specify A-GNSS signaling and performance requirements test cases. These test cases include subtest cases that require specific A-GNSS support by the user equipment (UE). The content of the assistance data depends on the subtest case.

For an overview of the 3GPP TS subtest cases, relevant subclause and A-GNSS support by the UE, see the following tables.

Table E-2: TS 37.571-2: Subtest cases per subclause and A-GNSS support by UE

Subtest case	Subclause UTRA (S6)	Subclause E-UTRA (S7)
ST1	A-GLONASS	A-GPS
ST2	A-Galileo	A-GLONASS
ST3	A-GPS and modernized GPS	A-Galileo
ST4	A-GPS and A-GLONASS	A-GPS and A-GLONASS
ST8	A-GPS and A-Galileo	A-GPS and A-Galileo
ST9	A-BDS	A-BDS
ST10	A-GPS and A-BDS	A-GPS and A-BDS

Table E-3: TS 37.571-1: Subtest cases per subclause and A-GNSS support by UE

Subtest case	Subclause UTRA (S6)	Subclause E-UTRA (S7)
ST1	A-GLONASS	A-GPS
ST2	A-Galileo	A-GLONASS
ST3	A-GPS and modernized GPS	A-Galileo
ST4	A-GPS and A-GLONASS	A-GPS and modernized GPS
ST5	-	A-GPS and A-GLONASS
ST8	A-GPS and A-Galileo	A-GPS and A-Galileo
ST9	A-BDS	A-BDS
ST10	A-GPS and A-BDS	A-GPS and A-BDS
ST11	A-GPS, A-GLONASS and A-BDS	A-GPS, A-GLONASS and A-BDS
ST12	A-GPS, A-Galileo and A-GLONASS	A-GPS, A-Galileo and A-GLONASS
ST13	A-GPS, A-Galileo and A-BDS	A-GPS, A-Galileo and A-BDS

E.2 Assisted GNSS test scenarios

This section lists all predefined scenarios in the folder "Assisted GNSS". The scenarios are grouped into subfolders of the corresponding cellular standard (GSM, 3GPP FDD, 3GPP2, EUTRA/LTE).

For each subfolder/cellular standard, a table provides an overview on scenario name, required options, motion type and location.

- For GSM scenarios, see [Table E-4](#).
- For 3GPP FDD scenarios, see [Table E-5](#).
- For 3GPP2 scenarios, see [Table E-6](#).
- For EUTRA/LTE scenarios, see [Table E-7](#).

To understand, which GNSS is used in which scenario, see the GNSS system options in the required options column of the table.

Table E-4: GSM subfolder: A-GNSS test scenarios

R&S SMW200A test scenario	Required options	Motion type	Location
3GPP TS 51.010: 10.9 Signaling	R&S SMW-K44	Static	Tokyo
3GPP TS 51.010: 10.10 Performance 1	R&S SMW-K44	Static	Tokyo
3GPP TS 51.010: 10.10 Performance 2	R&S SMW-K44	Static	Sunnyvale
3GPP TS 51.010: 10.10 Performance 3	R&S SMW-K44	Dynamic	Sunnyvale

Table E-5: 3GPP FDD subfolder: A-GNSS test scenarios

R&S SMW200A test scenario	Required options	Motion type	Location
3GPP TS 34.108: 10.7 Signaling	R&S SMW-K44	Static	Tokyo
3GPP TS 34.108: 10.1.2 Performance 1	R&S SMW-K44	Static	Tokyo
3GPP TS 34.108: 10.1.2 Performance 2	R&S SMW-K44	Static	Sunnyvale
3GPP TS 34.108: 10.1.2 Performance 3	R&S SMW-K44	Dynamic	Sunnyvale
3GPP TS 37.571-2: S6 Signaling ST1	R&S SMW-K94	Static	Tokyo
3GPP TS 37.571-2: S6 Signaling ST2	R&S SMW-K66	Static	Tokyo
3GPP TS 37.571-2: S6 Signaling ST4	R&S SMW-K44 R&S SMW-K94 R&S SMW-K136 *)	Static	Tokyo
3GPP TS 37.571-2: S6 Signaling ST8	R&S SMW-K44 R&S SMW-K66 R&S SMW-K136 *)	Static	Tokyo
3GPP TS 37.571-2: S6 Signaling ST9	R&S SMW-K107	Static	Tokyo
3GPP TS 37.571-2: S6 Signaling ST10	R&S SMW-K44 R&S SMW-K107 R&S SMW-K136 *)	Static	Tokyo
3GPP TS 37.571-1: S6 Performance 1 ST1	R&S SMW-K94	Static	Tokyo
3GPP TS 37.571-1: S6 Performance 1 ST2	R&S SMW-K66	Static	Tokyo
3GPP TS 37.571-1: S6 Performance 1 ST4	R&S SMW-K44 R&S SMW-K94	Static	Tokyo
3GPP TS 37.571-1: S6 Performance 1 ST8	R&S SMW-K44 R&S SMW-K66	Static	Tokyo
3GPP TS 37.571-1: S6 Performance 1 ST9	R&S SMW-K107	Static	Tokyo
3GPP TS 37.571-1: S6 Performance 1 ST10	R&S SMW-K44 R&S SMW-K107	Static	Tokyo
3GPP TS 37.571-1: S6 Performance 2 ST1	R&S SMW-K94	Static	Sunnyvale
3GPP TS 37.571-1: S6 Performance 2 ST2	R&S SMW-K66	Static	Sunnyvale

R&S SMW200A test scenario	Required options	Motion type	Location
3GPP TS 37.571-1: S6 Performance 2 ST4	R&S SMW-K44 R&S SMW-K94	Static	Sunnyvale
3GPP TS 37.571-1: S6 Performance 2 ST8	R&S SMW-K44 R&S SMW-K66	Static	Sunnyvale
3GPP TS 37.571-1: S6 Performance 2 ST9	R&S SMW-K107	Static	Sunnyvale
3GPP TS 37.571-1: S6 Performance 2 ST10	R&S SMW-K44 R&S SMW-K107	Static	Sunnyvale
3GPP TS 37.571-1: S6 Performance 5 ST1	R&S SMW-K94	Dynamic	Sunnyvale
3GPP TS 37.571-1: S6 Performance 5 ST2	R&S SMW-K66	Dynamic	Sunnyvale
3GPP TS 37.571-1: S6 Performance 5 ST4	R&S SMW-K44 R&S SMW-K94	Dynamic	Sunnyvale
3GPP TS 37.571-1: S6 Performance 5 ST8	R&S SMW-K44 R&S SMW-K66	Dynamic	Sunnyvale
3GPP TS 37.571-1: S6 Performance 5 ST9	R&S SMW-K107	Dynamic	Sunnyvale
3GPP TS 37.571-1: S6 Performance 5 ST10	R&S SMW-K44 R&S SMW-K107	Dynamic	Sunnyvale

*) TS 37.571-2 S6 signaling scenarios, subtests 4, 8 and 10 require additional channel options (e.g. R&S SMW-K136). These subtests require a larger simulation capacity for simulating more complex hybrid GNSS satellite constellations.

Table E-6: 3GPP2 subfolder: A-GNSS test scenarios

R&S SMW200A test scenario	Required options	Motion type	Location
3GPP2 C.S0036 2.1.1 Stationary	R&S SMW-K44	Static	Sunnyvale
3GPP2 C.S0036 2.1.2 Moving	R&S SMW-K44 R&S SMW-K136 *)	Dynamic	Sunnyvale

*) 3GPP2 C.S0036 2.1.2 Moving scenario requires additional channel option (e.g. R&S SMW-K136). These subtests require a larger simulation capacity for simulating more complex hybrid GNSS satellite constellations.

Table E-7: EUTRA/LTE folder: A-GNSS test scenarios

R&S SMW200A test scenario	Required options	Motion type	Location
3GPP TS 37.571-2: S7 Signaling ST1	R&S SMW-K44	Static	Tokyo
3GPP TS 37.571-2: S7 Signaling ST2	R&S SMW-K94	Static	Tokyo
3GPP TS 37.571-2: S7 Signaling ST3	R&S SMW-K66	Static	Tokyo
3GPP TS 37.571-2: S7 Signaling ST4	R&S SMW-K44 R&S SMW-K94 R&S SMW-K136 *)	Static	Tokyo

R&S SMW200A test scenario	Required options	Motion type	Location
3GPP TS 37.571-2: S7 Signaling ST8	R&S SMW-K44 R&S SMW-K66 R&S SMW-K136 *)	Static	Tokyo
3GPP TS 37.571-2: S7 Signaling ST9	R&S SMW-K107	Static	Tokyo
3GPP TS 37.571-2: S7 Signaling ST10	R&S SMW-K44 R&S SMW-K107 R&S SMW-K136 *)	Static	Tokyo
3GPP TS 37.571-2: S7 Signaling ST15	R&S SMW-K44 R&S SMW-K66 R&S SMW-K94 R&S SMW-K107 4 x R&S SMW-K136 *)	Static	Tokyo
3GPP TS 37.571-1: S7 Performance 1 ST1	R&S SMW-K44	Static	Tokyo
3GPP TS 37.571-1: S7 Performance 1 ST2	R&S SMW-K94	Static	Tokyo
3GPP TS 37.571-1: S7 Performance 1 ST3	R&S SMW-K66	Static	Tokyo
3GPP TS 37.571-1: S7 Performance 1 ST5	R&S SMW-K44 R&S SMW-K94	Static	Tokyo
3GPP TS 37.571-1: S7 Performance 1 ST8	R&S SMW-K44 R&S SMW-K66	Static	Tokyo
3GPP TS 37.571-1: S7 Performance 1 ST9	R&S SMW-K107	Static	Tokyo
3GPP TS 37.571-1: S7 Performance 1 ST10	R&S SMW-K44 R&S SMW-K107	Static	Tokyo
3GPP TS 37.571-1: S7 Performance 1 ST11	R&S SMW-K44 R&S SMW-K94 R&S SMW-K107	Static	Tokyo
3GPP TS 37.571-1: S7 Performance 1 ST12	R&S SMW-K44 R&S SMW-K66 R&S SMW-K94	Static	Tokyo
3GPP TS 37.571-1: S7 Performance 1 ST13	R&S SMW-K44 R&S SMW-K66 R&S SMW-K107	Static	Tokyo
3GPP TS 37.571-1: S7 Performance 2 ST1	R&S SMW-K44	Static	Sunnyvale
3GPP TS 37.571-1: S7 Performance 2 ST2	R&S SMW-K94	Static	Sunnyvale
3GPP TS 37.571-1: S7 Performance 2 ST3	R&S SMW-K66	Static	Sunnyvale
3GPP TS 37.571-1: S7 Performance 2 ST5	R&S SMW-K44 R&S SMW-K94	Static	Sunnyvale

R&S SMW200A test scenario	Required options	Motion type	Location
3GPP TS 37.571-1: S7 Performance 2 ST8	R&S SMW-K44 R&S SMW-K66	Static	Sunnyvale
3GPP TS 37.571-1: S7 Performance 2 ST9	R&S SMW-K107	Static	Sunnyvale
3GPP TS 37.571-1: S7 Performance 2 ST10	R&S SMW-K44 R&S SMW-K107	Static	Sunnyvale
3GPP TS 37.571-1: S7 Performance 2 ST11	R&S SMW-K44 R&S SMW-K94 R&S SMW-K107	Static	Sunnyvale
3GPP TS 37.571-1: S7 Performance 2 ST12	R&S SMW-K44 R&S SMW-K66 R&S SMW-K94	Static	Sunnyvale
3GPP TS 37.571-1: S7 Performance 2 ST13	R&S SMW-K44 R&S SMW-K66 R&S SMW-K107	Static	Sunnyvale
3GPP TS 37.571-1: S7 Performance 5 ST1	R&S SMW-K44	Dynamic	Sunnyvale
3GPP TS 37.571-1: S7 Performance 5 ST2	R&S SMW-K94	Dynamic	Sunnyvale
3GPP TS 37.571-1: S7 Performance 5 ST3	R&S SMW-K66	Dynamic	Sunnyvale
3GPP TS 37.571-1: S7 Performance 5 ST5	R&S SMW-K44 R&S SMW-K94	Dynamic	Sunnyvale
3GPP TS 37.571-1: S7 Performance 5 ST8	R&S SMW-K44 R&S SMW-K66	Dynamic	Sunnyvale
3GPP TS 37.571-1: S7 Performance 5 ST9	R&S SMW-K107	Dynamic	Sunnyvale
3GPP TS 37.571-1: S7 Performance 5 ST10	R&S SMW-K44 R&S SMW-K107	Dynamic	Sunnyvale
3GPP TS 37.571-1: S7 Performance 5 ST11	R&S SMW-K44 R&S SMW-K94 R&S SMW-K107	Dynamic	Sunnyvale
3GPP TS 37.571-1: S7 Performance 5 ST12	R&S SMW-K44 R&S SMW-K66 R&S SMW-K94	Dynamic	Sunnyvale
3GPP TS 37.571-1: S7 Performance 5 ST13	R&S SMW-K44 R&S SMW-K66 R&S SMW-K107	Dynamic	Sunnyvale

*) TS 37.571-2 S7 signaling scenarios, subtests 4, 8, 10 and 15 require additional channel options (e.g. R&S SMW-K136). These subtests require a larger simulation capacity for simulating more complex hybrid GNSS satellite constellations.

E.3 Assisted GNSS 2020 test scenarios

This section lists all predefined scenarios in the folder "Assisted GNSS 2020". The scenarios are grouped into subfolders of the corresponding cellular standard (3GPP FDD 2020, EUTRA/LTE 2020).

For each subfolder/cellular standard, a table provides an overview on scenario name, required options, motion type and location.

- For 3GPP FDD 2020 scenarios, see [Table E-8](#).
- For EUTRA/LTE 2020 scenarios, see [Table E-9](#).

To understand, which GNSS is used in which scenario, see the GNSS system options in the required options column of the table.

Table E-8: 3GPP FDD 2020 subfolder: A-GNSS test scenarios

R&S SMW200A test scenario	Required options	Motion type	Location
3GPP-2020 TS 37.571-2: S6 Signaling ST1	R&S SMW-K94	Static	Tokyo
3GPP-2020 TS 37.571-2: S6 Signaling ST2	R&S SMW-K66	Static	Tokyo
3GPP-2020 TS 37.571-2: S6 Signaling ST3	R&S SMW-K44	Static	Tokyo
3GPP-2020 TS 37.571-2: S6 Signaling ST4	R&S SMW-K44 R&S SMW-K94 R&S SMW-K136 *)	Static	Tokyo
3GPP-2020 TS 37.571-2: S6 Signaling ST8	R&S SMW-K44 R&S SMW-K66 R&S SMW-K136 *)	Static	Tokyo
3GPP-2020 TS 37.571-2: S6 Signaling ST9	R&S SMW-K107	Static	Tokyo
3GPP-2020 TS 37.571-2: S6 Signaling ST10	R&S SMW-K44 R&S SMW-K107 R&S SMW-K136 *)	Static	Tokyo
3GPP-2020 TS 37.571-1: S6 Performance 1 ST1	R&S SMW-K94	Static	Tokyo
3GPP-2020 TS 37.571-1: S6 Performance 1 ST2	R&S SMW-K66	Static	Tokyo
3GPP-2020 TS 37.571-1: S6 Performance 1 ST3	R&S SMW-K44	Static	Tokyo
3GPP-2020 TS 37.571-1: S6 Performance 1 ST4	R&S SMW-K44 R&S SMW-K94	Static	Tokyo
3GPP-2020 TS 37.571-1: S6 Performance 1 ST8	R&S SMW-K44 R&S SMW-K66	Static	Tokyo
3GPP-2020 TS 37.571-1: S6 Performance 1 ST9	R&S SMW-K107	Static	Tokyo
3GPP-2020 TS 37.571-1: S6 Performance 1 ST10	R&S SMW-K44 R&S SMW-K107	Static	Tokyo
3GPP-2020 TS 37.571-1: S6 Performance 2 ST1	R&S SMW-K94	Static	Sunnyvale
3GPP-2020 TS 37.571-1: S6 Performance 2 ST2	R&S SMW-K66	Static	Sunnyvale

Assisted GNSS 2020 test scenarios

R&S SMW200A test scenario	Required options	Motion type	Location
3GPP-2020 TS 37.571-1: S6 Performance 2 ST3	R&S SMW-K44 R&S SMW-K136 *)	Static	Sunnyvale
3GPP-2020 TS 37.571-1: S6 Performance 2 ST4	R&S SMW-K44 R&S SMW-K94	Static	Sunnyvale
3GPP-2020 TS 37.571-1: S6 Performance 2 ST8	R&S SMW-K44 R&S SMW-K66	Static	Sunnyvale
3GPP-2020 TS 37.571-1: S6 Performance 2 ST9	R&S SMW-K107	Static	Sunnyvale
3GPP-2020 TS 37.571-1: S6 Performance 2 ST10	R&S SMW-K44 R&S SMW-K107	Static	Sunnyvale
3GPP-2020 TS 37.571-1: S6 Performance 5 ST1	R&S SMW-K94	Dynamic	Sunnyvale
3GPP-2020 TS 37.571-1: S6 Performance 5 ST2	R&S SMW-K66	Dynamic	Sunnyvale
3GPP-2020 TS 37.571-1: S6 Performance 5 ST3	R&S SMW-K44 R&S SMW-K136 *)	Dynamic	Sunnyvale
3GPP-2020 TS 37.571-1: S6 Performance 5 ST4	R&S SMW-K44 R&S SMW-K94	Dynamic	Sunnyvale
3GPP-2020 TS 37.571-1: S6 Performance 5 ST8	R&S SMW-K44 R&S SMW-K66	Dynamic	Sunnyvale
3GPP-2020 TS 37.571-1: S6 Performance 5 ST9	R&S SMW-K107	Dynamic	Sunnyvale
3GPP-2020 TS 37.571-1: S6 Performance 5 ST10	R&S SMW-K44 R&S SMW-K107	Dynamic	Sunnyvale

*) TS 37.571-2 S6 signaling scenarios, subtests 4, 8 and 10 and TS 37.571-1 S6 performance scenarios, subtests 2 and 3 require additional channel options (e.g. R&S SMW-K136). These subtests require a larger simulation capacity for simulating more complex hybrid GNSS satellite constellations.

Table E-9: EUTRA/LTE 2020 folder: A-GNSS test scenarios

R&S SMW200A test scenario	Required options	Motion type	Location
3GPP-2020 TS 37.571-2: S7 Signaling ST15	R&S SMW-K44 R&S SMW-K66 R&S SMW-K94 R&S SMW-K107 4 x R&S SMW-K136 *)	Static	Tokyo
3GPP-2020 TS 37.571-1: S7 Performance 1 ST1	R&S SMW-K44 R&S SMW-K136 *)	Static	Tokyo
3GPP-2020 TS 37.571-1: S7 Performance 1 ST2	R&S SMW-K94	Static	Tokyo
3GPP-2020 TS 37.571-1: S7 Performance 1 ST3	R&S SMW-K66	Static	Tokyo
3GPP-2020 TS 37.571-1: S7 Performance 1 ST4	R&S SMW-K44	Static	Tokyo

Assisted GNSS 2020 test scenarios

R&S SMW200A test scenario	Required options	Motion type	Location
3GPP-2020 TS 37.571-1: S7 Performance 1 ST5	R&S SMW-K44 R&S SMW-K94	Static	Tokyo
3GPP-2020 TS 37.571-1: S7 Performance 1 ST8	R&S SMW-K44 R&S SMW-K66	Static	Tokyo
3GPP-2020 TS 37.571-1: S7 Performance 1 ST9	R&S SMW-K107	Static	Tokyo
3GPP-2020 TS 37.571-1: S7 Performance 1 ST10	R&S SMW-K44 R&S SMW-K107	Static	Tokyo
3GPP-2020 TS 37.571-1: S7 Performance 1 ST11	R&S SMW-K44 R&S SMW-K94 R&S SMW-K107	Static	Tokyo
3GPP-2020 TS 37.571-1: S7 Performance 1 ST12	R&S SMW-K44 R&S SMW-K66 R&S SMW-K94	Static	Tokyo
3GPP-2020 TS 37.571-1: S7 Performance 1 ST13	R&S SMW-K44 R&S SMW-K66 R&S SMW-K107	Static	Tokyo
3GPP-2020 TS 37.571-1: S7 Performance 1 GQ	R&S SMW-K44 R&S SMW-K106	Static	Tokyo
3GPP-2020 TS 37.571-1: S7 Performance 2 ST1	R&S SMW-K44 R&S SMW-K136 *)	Static	Sunnyvale
3GPP-2020 TS 37.571-1: S7 Performance 2 ST2	R&S SMW-K94	Static	Sunnyvale
3GPP-2020 TS 37.571-1: S7 Performance 2 ST3	R&S SMW-K66	Static	Sunnyvale
3GPP-2020 TS 37.571-1: S7 Performance 2 ST4	R&S SMW-K44 R&S SMW-K136 *)	Static	Sunnyvale
3GPP-2020 TS 37.571-1: S7 Performance 2 ST5	R&S SMW-K44 R&S SMW-K94	Static	Sunnyvale
3GPP-2020 TS 37.571-1: S7 Performance 2 ST8	R&S SMW-K44 R&S SMW-K66	Static	Sunnyvale
3GPP-2020 TS 37.571-1: S7 Performance 2 ST9	R&S SMW-K107	Static	Sunnyvale
3GPP-2020 TS 37.571-1: S7 Performance 2 ST10	R&S SMW-K44 R&S SMW-K107	Static	Sunnyvale
3GPP-2020 TS 37.571-1: S7 Performance 2 ST11	R&S SMW-K44 R&S SMW-K94 R&S SMW-K107	Static	Sunnyvale
3GPP-2020 TS 37.571-1: S7 Performance 2 ST12	R&S SMW-K44 R&S SMW-K66 R&S SMW-K94	Static	Sunnyvale

R&S SMW200A test scenario	Required options	Motion type	Location
3GPP-2020 TS 37.571-1: S7 Performance 2 ST13	R&S SMW-K44 R&S SMW-K66 R&S SMW-K107	Static	Sunnyvale
3GPP-2020 TS 37.571-1: S7 Performance 3B GN	R&S SMW-K44 R&S SMW-K97	Static	Sigar
3GPP-2020 TS 37.571-1: S7 Performance 4B GN	R&S SMW-K44 R&S SMW-K97	Static	Maldives
3GPP-2020 TS 37.571-1: S7 Performance 4D GQ	R&S SMW-K44 R&S SMW-K106	Static	Kyoto
3GPP-2020 TS 37.571-1: S7 Performance 5 ST1	R&S SMW-K44	Dynamic	Sunnyvale
3GPP-2020 TS 37.571-1: S7 Performance 5 ST2	R&S SMW-K94	Dynamic	Sunnyvale
3GPP-2020 TS 37.571-1: S7 Performance 5 ST3	R&S SMW-K66	Dynamic	Sunnyvale
3GPP-2020 TS 37.571-1: S7 Performance 5 ST4	R&S SMW-K44 R&S SMW-K136 *)	Dynamic	Sunnyvale
3GPP-2020 TS 37.571-1: S7 Performance 5 ST5	R&S SMW-K44 R&S SMW-K94	Dynamic	Sunnyvale
3GPP-2020 TS 37.571-1: S7 Performance 5 ST8	R&S SMW-K44 R&S SMW-K66	Dynamic	Sunnyvale
3GPP-2020 TS 37.571-1: S7 Performance 5 ST9	R&S SMW-K107	Dynamic	Sunnyvale
3GPP-2020 TS 37.571-1: S7 Performance 5 ST10	R&S SMW-K44 R&S SMW-K107	Dynamic	Sunnyvale
3GPP-2020 TS 37.571-1: S7 Performance 5 ST11	R&S SMW-K44 R&S SMW-K94 R&S SMW-K107	Dynamic	Sunnyvale
3GPP-2020 TS 37.571-1: S7 Performance 5 ST12	R&S SMW-K44 R&S SMW-K66 R&S SMW-K94	Dynamic	Sunnyvale
3GPP-2020 TS 37.571-1: S7 Performance 5 ST13	R&S SMW-K44 R&S SMW-K66 R&S SMW-K107	Dynamic	Sunnyvale

*) TS 37.571-2 S7 signaling scenario, subtest 15 and TS 37.571-2 S7 performance scenarios, subtests 1 and 3 require additional channel options (e.g. R&S SMW-K136). These subtests require a larger simulation capacity for simulating more complex hybrid GNSS satellite constellations.

E.4 Real constellations reference scenarios

This section lists predefined scenarios in the folder "Real Constellations Reference Scenarios", see [Table E-10](#). The subfolder provides one scenario with navigation data and satellite constellations for GPS, Galileo, GLONASS and BeiDou. The data is provided from the specific GNSS reference stations for a certain date ("2022-07-25").

To simulate the reference scenario, install the basic GNSS system options as in column "Required options" below.

Table E-10: 2022-07-25 Broadcast Data subfolder: Test scenarios

R&S SMW200A test scenario	Required options
2022-07-25 GPS GAL GLO BDS	R&S SMW-K44 R&S SMW-K66 R&S SMW-K94 R&S SMW-K107

E.5 Galileo OSNMA scenarios

If equipped with R&S SMW-K66, the R&S SMW200A supports predefined scenarios related to Galileo OSNMA test vectors. For a list of predefined scenarios in the "Galileo OSNMA" folder, see [Table 10-2](#).

F Ionospheric grid file format

Customized ionospheric grids can be exported and saved as *.iono_grid files. Such files can be imported and used for the simulation of the MOPS-D0-229D ionospheric model. If imported together with *.ems or *.nstb files, custom ionospheric grid files can also be mixed with the SBAS files, for example to create an ionospheric grid covering the entire world map. See [Example"Importing grid files"](#) on page 428 for an example grid configuration.

The *.iono_grid files are XML files in a Rohde & Schwarz proprietary file format . They contain Vertical Delay, GIVEI value pairs with 5° and 15 minutes resolution.

Example: Ionospheric grid file content (extract)

```
<?xml version="1.0" encoding="ISO-8859-1"?>
<REGION sys = "EGNOS">
<IODI init_val="0"/>
<IGP_GRID DateTime="19-02-2014 06:11:47">
<data>
  -180      -175      -170      -165      -160 ... 170      175
    85     none     none     none     none ... none     none
  ...
  -85     none     none     none     none ... none     none
</data>
</IGP_GRID>
...
<IGP_GRID DateTime="19-02-2014 06:27:57">
<data>
  -180      -175      -170      -165      -160 ... 170      175
    85     none     none     none     none ... none     none
  ...
  -85     none     none     none     none ... none     none
</data>
</IGP_GRID>
</REGION>
```

G Channel budget

The number of GNSS channels that you can simulate depends on the instrument hardware and installed options. GNSS system options and "Add x GNSS channels" options contribute to the number of available channels. Adding more GNSS system options does increase the number of available channels. Install "Add x GNSS channels" to increase simulation capacity.

For more information, refer to the specifications document.

Hardware options and channel budget

If fully equipped as a wideband instrument, the R&S SMW200A has a simulation capacity of maximum 612 channels. The number results from the baseband allocation using six boards (2 CODER boards and 4 FADER boards) and a maximum 102 channels per board.

So, additional to the "Add x GNSS channels" options, you can equip the R&S SMW200A with more boards to simulate more than 102 GNSS channels. See [Table G-1](#).

Table G-1: Hardware options (boards) and channel budget

Option	Designation	Number of options	Max. channels
R&S SMW-B9	Wideband baseband generator (CODER)	1	102
		2	204
R&S SMW-B15	Fading simulator and signal processor (FADER)	2	204
		4	408
All	-	6	612



Integer number of boards required to increase simulation capacity

To increase the simulation capacity of 102 channels, equip the R&S SMW200A with an integer number of board options and add channel options as you need.

Example:

Increasing simulation capacity from 102 to 103 GNSS channels requires two additional options:

Second option R&S SMW-B9 and R&S SMW-K136 (add six GNSS channels).

Increasing simulation capacity from 204 to 205 GNSS channels requires three additional options:

Two options R&S SMW-B15 and R&S SMW-K136 (add six GNSS channels).

See also [Chapter G.2, "Instrument setups"](#), on page 685.

The maximum simulation capacity of 102 channels per board implies the same maximum simulation capacity per signal path for "System Configuration" > "Fading/Baseband Config" > "Mode" > "Standard".

Table G-2: Options and channel budget for single path R&S SMW-B9

Option	Designation	Number of options	Max. channels
R&S SMW-B9	Wideband baseband generator	1 to 2	24
R&S SMW-K<x> ¹⁾	GNSS system option	1 to 2	
R&S SMW-K136	Add 6 GNSS channels	1 to 8	72
R&S SMW-K137	Add 12 GNSS channels	1 to 6 ²⁾	72
R&S SMW-K138	Add 24 GNSS channels	1 to 3 ²⁾	72
R&S SMW-K139	Add 48 GNSS channels	1 ²⁾	48
All	-	-	102

¹⁾ K<x> denotes a GNSS system option: R&S SMW-K44/K66/K94/K97/K98/K107/K132

²⁾ Channel capacity of maximum 102 channels restricts the number of installable options to add GNSS channels.

To simulate more than 204 GNSS channels combined from both instrument paths [enable advanced mode](#).

G.1 Hardware resources

This chapter considers the hardware resource allocation for a wideband instrument (R&S SMW-B9).

The field programmable gate array (FPGA) of the R&S SMW200A consists of three banks (0 to 2) and several subbanks used for the generation of GNSS signals. Each bank can simulate only one frequency band L1, L2 or L5 at a time. The frequency band is assigned automatically, so that a maximum number of hardware resources from the FPGA banks are used.



A maximum number of 102 GNSS channels can be simulated. A limiting factor is the limited number of visible satellites within the satellite constellation.

The table below illustrates the FPGA structure, the supported [signals](#) by the subbanks and the FPGA channel capacity.

Bank	Subbank	Signal	Channel capacity
0	0_A	C/A, E1 OS, B1I, L5 SPS	12
	0_B	C/A, E1 OS, B1I, L5, E5a, E5b, B2I, L5 SPS	12
	0_C	C/A, E1 OS, B1I, P, L5, E5a, E5b, B2I, L5 SPS	18
	All subbanks	All signals except L2C	42
1	1_A	C/A, E1 OS, B1I, L2C, L5, E5a, E5b, B2I, L5 SPS	16

Bank	Subbank	Signal	Channel capacity
	1_B	C/A, E1 OS, B1I, P, L5, E5a, E5b, B2I, L5 SPS	16
	All subbanks	All signals	32
2	2_A	C/A, E1 OS, B1I, L2C, L5, E5a, E5b, B2I, L5 SPS	28
	All subbanks	All signals except P	28
All banks			102

In the following, a few examples illustrate the channel capacity and the used FPGA resources.

- [Example"GPS L1 and L2 band with C/A and P signals"](#) on page 684
- [Example"GPS L1, L2, L5 signals and one echo signal per satellite"](#) on page 684
- [Example"GPS and Galileo L1 and L5 signals"](#) on page 685
- [Example"GPS and GLONASS L1 and L2 signals"](#) on page 685

Example: GPS L1 and L2 band with C/A and P signals

Bank	Subbank	Band and signal	Channel capacity
0	0_A	L1 C/A	11 ¹⁾
	0_B	L1 P	11 ¹⁾
1	1_A	L2 C/A	11 ¹⁾
	1_B	L2 P	11 ¹⁾
2	-	-	0
All banks			44

¹⁾ A maximum of 11 GPS satellites are visible. You can increase the number of channels to depends on installed options by adding non-visible satellites, but they are not simulated in the composite GNSS signal.

Example: GPS L1, L2, L5 signals and one echo signal per satellite

Bank	Subbank	Band and signal	Channel capacity
0	0_A	L1 C/A	12 ¹⁾
	0_B	L1 C/A	6 ¹⁾
1	1_A	L2 C/A	16 ¹⁾
	1_B	L2 C/A	2 ¹⁾
2	2_A	L5 GPS L5	18 ¹⁾
All banks			54

¹⁾ 9 GPS satellites and one echo signal for each satellite are simulated.

Example: GPS and Galileo L1 and L5 signals

Bank	Subbanks	Band and signal	Channel capacity
0	0_A	L1 C/A or L1 E1OS	12 ¹⁾
	0_B	L1 C/A or L1 E1OS	7 ¹⁾
1	1_A	L1 C/A or L1 E1OS	9 ¹⁾
2	2_A	L5, L5 E5a, L5 E5b	18 ¹⁾
All banks			46

¹⁾ 9 GPS and 8 Galileo satellites are simulated.

Example: GPS and GLONASS L1 and L2 signals

Bank	Subbanks	Band and signal	Channel capacity
0	0_A	L1 C/A	12 ¹⁾
	0_B	L1 C/A	8 ¹⁾
1	1_A	L2 C/A	11 ¹⁾
	1_B	L2 C/A	9 ¹⁾
All banks			40

¹⁾ 11 GPS and 9 GLONASS satellites are simulated.

G.2 Instrument setups

The following examples show required options and the simulation capacity for different R&S SMW200A setups:

- [Example "GNSS single-frequency constellation simulator \(R&S SMW-B9\)"](#) on page 685
- [Example "GNSS triple-frequency constellation simulator \(R&S SMW-B9\)"](#) on page 686
- [Example "GPS L1 + L5 constellation simulator \(R&S SMW-B9\)"](#) on page 686
- [Example "GPS L1 + L2 + L5 constellation simulator \(R&S SMW-B9\)"](#) on page 687

Example: GNSS single-frequency constellation simulator (R&S SMW-B9)

The example assumes a single-path wideband instrument as in [Table G-2](#).

Table G-3: Options and simulation capacity for single path R&S SMW-B9

Option	Description	Requirement	Max. channels	Max. SV
R&S SMW-B9	Wideband baseband generator	Mandatory	24	> 6 ²⁾
R&S SMW-B13XT	Wideband main module	Mandatory		

Option	Description	Requirement	Max. channels	Max. SV
R&S SMW-B1003	Frequency	Mandatory		
R&S SMW-K _x ¹⁾	GNSS system option	Mandatory		
R&S SMW-K136	Add 6 GNSS channels	Optional	42 = 7 x 6	> 6 ²⁾
R&S SMW-K137	Add 12 GNSS channels	Optional	36 = 3 x 12	> 6 ²⁾
All	-	-	102	> 6 ²⁾

¹⁾ K_x denotes a GNSS system option: R&S SMW-K44/K66/K94/K97/K98/K107/K132

²⁾ The maximum number of space vehicles depends on the visibility state of the satellite.

Example: GNSS triple-frequency constellation simulator (R&S SMW-B9)

The example assumes a single-path wideband instrument as in [Example"GNSS single-frequency constellation simulator \(R&S SMW-B9\)"](#) on page 685. Mandatory options listed in the table below are additional to the mandatory options in [Table G-3](#).

Table G-4: Options and simulation capacity for single path R&S SMW-B9

Option	Description	Requirement	Max. channels	Max. SV
R&S SMW-K134	Upgrade to dual-frequency	Optional	24	> 6 ²⁾
R&S SMW-K135 ¹⁾	Upgrade to triple-frequency	Optional		
R&S SMW-K136	Add 6 GNSS channels	Optional	42 = 7 x 6	> 6 ²⁾
R&S SMW-K137	Add 12 GNSS channels	Optional	36 = 3 x 12	> 6 ²⁾
All	-	-	102	> 6 ²⁾

¹⁾ R&S SMW-K135 requires R&S SMW-K134.

²⁾ The maximum number of space vehicles depends on the visibility state of the satellite.

Example: GPS L1 + L5 constellation simulator (R&S SMW-B9)

The example assumes a single-path wideband instrument as in [Example"GNSS single-frequency constellation simulator \(R&S SMW-B9\)"](#) on page 685. Mandatory GPS options listed in the table below replace the mandatory GNSS system option in [Table G-3](#).

Simulation of both GPS L1 and L5 signals requires both basic GPS and modernized GPS options. Signal generation on one RF carrier requires the option "Upgrade to dual-frequency".

Option	Description	Requirement	Max. channels	Max. SV
R&S SMW-K44	Basic GPS	Mandatory	24 ¹⁾	6 ²⁾
R&S SMW-K98	Modernized GPS	Mandatory		
R&S SMW-K134	Upgrade to dual-frequency	Mandatory		> 6 ²⁾

Option	Description	Requirement	Max. channels	Max. SV
R&S SMW-K136	Add 6 GNSS channels	Optional	42 = 7 x 6	> 6 ²⁾
R&S SMW-K137	Add 12 GNSS channels	Optional	36 = 3 x 12	> 6 ²⁾
All	-	-	102	> 6 ²⁾

¹⁾ The maximum number of channels is limited to 24 channels. Adding GNSS system options or frequency options does not increase the number of channels.

²⁾ The maximum number of space vehicles depends on the visibility state of the satellite.

Example: GPS L1 + L2 + L5 constellation simulator (R&S SMW-B9)

The example assumes a single-path wideband instrument as in [Example "GNSS single-frequency constellation simulator \(R&S SMW-B9\)"](#) on page 685. Mandatory GPS options listed in the table below replace the mandatory GNSS system option in [Table G-3](#).

Simulation of both GPS L1, L2 and L5 signals requires both basic GPS and modernized GPS options. Signal generation on one RF carrier requires options "Upgrade to dual-frequency" and "Upgrade to triple-frequency". See also the table below for a comprehensive overview.

Option	Description	Requirement	Max. channels	Max. SV
R&S SMW-K44	Basic GPS	Mandatory	24 ¹⁾	6 ²⁾
R&S SMW-K98	Modernized GPS	Mandatory		
R&S SMW-K134	Upgrade to dual-frequency	Mandatory		
R&S SMW-K135 ³⁾	Upgrade to triple-frequency	Mandatory		
R&S SMW-K136	Add 6 GNSS channels	Optional	42 = 7 x 6	> 6 ²⁾
R&S SMW-K137	Add 12 GNSS channels	Optional	36 = 3 x 12	> 6 ²⁾
All	-	-	102	> 6 ²⁾

¹⁾ The maximum number of channels is limited to six channels. Adding GNSS system options does not increase the number of channels.

²⁾ The maximum number of space vehicles depends on the visibility state of the satellite.

³⁾ R&S SMW-K135 requires R&S SMW-K134.

H List of predefined files

If the required options are installed, the firmware provides the following predefined files:

Application	File type	File extension	Filename
Body mask	Body mask files	*.body_mask	Bus.body_mask Car_Medium.body_mask Car_Medium_OpenRoof.body_mask Car_Small.body_mask Car_Small_OpenRoof.body_mask Isotropic.body_mask Jet.body_mask Jet_Big.body_mask Plane.body_mask Ship_Big.body_mask Ship_Medium.body_mask Space_Vehicle_3_antennas.body_mask SUV.body_mask Van.body_mask Yacht_Small.body_mask
Antenna pattern	Antenna pattern files	*.ant_pat	Isotropic.ant_pat PatchAntenna.ant_pat
SBAS corrections	Raw data	*.nstb *.ems	PRN120_19_02_14.ems PRN120_20_08_12.ems PRN126_19_02_14.ems
Vehicle description	XVD	*.xvd	Aircraft1.xvd LandVehicle1.xvd Pedestrian1.xvd Ship1.xvd Small_Jet.xvd Spacecraft1.xvd Speed_Boat.xvd Sports_Car.xvd Truck.xvd HiL_Jet_Aircraft.xvd HiL_Helicopter.xvd HiL_Big_Aircraft.xvd HiL_Small_Aircraft.xvd

Application	File type	File extension	Filename
Motion description	Waypoint files	*.txt	3gpp_eutra_per5.txt
			3gpp2.txt
			CCN_Beijing_standard_trajectory.txt
			Melbourne.txt
			Melbourne_Movement.txt
			Misc_Tokyo_GPS_Moving.txt
			Misc_Tokyo_GPS_Moving_2012.txt
			Misc_Tokyo_SUPL_AreaEvent.txt
			Misc_Tokyo_SUPL_AreaEvent_2012.txt
			Scen_Circle_5km.txt
			Scen_City_Block.txt
			Scen_Parking_10min.txt
			Scen_Parking_1h.txt
			Scen_Parking_1min.txt
			Scen_Urban_Canyon_1.txt
	XTD	*.xtd	Circle_Motion_VMag.xtd
			Barcelona_Ship_Cruise.xtd
			Melbourne_Car_Motion.xtd
			Munich_Flight.xtd
			NewYork_City_Walk.xtd
			Nuerburgring_Race_VelComp.xtd
			Nuerburgring_Race_VelMag.xtd
			Small_Jet_Flight.xtd
			Spacecraft_Motion.xtd
	KML	*.kml	Nuerburgring_Race.kml
	NMEA	*.nmea	Melbourne_nmea.nmea
	TLE	*.tle	International_Space_Station.tle

Glossary: Specifications and references

Symbols

[1]: <https://www.navipedia.net>

1GP102: Rohde & Schwarz application note [1GP102](#) "Generation of GNSS Signals in a Hardware in the Loop (HIL) Environment"

1MA263: Rohde & Schwarz application note [1MA263](#) "Ground station testing on satellites in orbit"

B

BeiDou ICD: BeiDou Navigation Satellite System interface control documents available at:
<https://en.beidou.gov.cn/SYSTEMS/ICD/>

D

Di Giovanni and Radicella, 1990: Di Giovanni, G. and Radicella, S. M., 1990. An analytical model of the electron density profile in the ionosphere. Advances in Space Research

G

Galileo ICD: Galileo European global navigation satellite system interface control documents.
For copyright information and technical information in Galileo documents, see latest versions of these documents available at the European GNSS service center (GSC):
<https://www.gsc-europa.eu/electronic-library/programme-reference-documents>

GFM312: Rohde & Schwarz application note [GFM312](#) "Next generation eCall conformance testing"

GLONASS ICD: Global navigation satellite system (GLONASS) interface control documents available at:
<https://glonass-iac.ru/en/documents/>

GPS ICD: Global positioning system (GPS) interface control documents available at:
<https://www.gps.gov/technical/icwg/>

J

JAXA: The Japan Aerospace Exploration Agency

N

NavIC ICD: NavIC/Indian regional navigation satellite system (IRNSS) interface control documents available at:
<https://www.isro.gov.in/IRNSSSignal.html>

Q

QZSS ICD: Quasi-zenith satellite system (QZSS) interface control documents available at:
<https://qzss.go.jp/en/technical/ps-is-qzss/ps-is-qzss.html>

R

RTCA MOPS DO-229: "Minimum Operational Performance Standards for Global Positioning System/Wide Area Augmentation System Airborne Equipment", 13 Dec 2006

S

STANAG: NATO Standard Agreement STANAG 4294 Issue 1

T

TLE: NASA/NORAD Two Line Elements (TLE) file format available at:
<https://celestrak.org/NORAD/elements/>

TS 34.108: 3GPP TS 34.108 "Common test environments for User Equipment (UE); Conformance testing"

TS 34.171: 3GPP TS 34.171 "Terminal conformance specification; Assisted Global Positioning System (A-GPS); Frequency Division Duplex (FDD)"

TS 37.571-1: 3GPP TS 37.571-1 "User Equipment (UE) conformance specification for UE positioning; Part 1: Conformance test specification "

TS 37.571-2: 3GPP TS 37.571-2 "User Equipment (UE) conformance specification for UE positioning; Part 2: Protocol conformance"

TS 51.010-1: 3GPP TS 51.010-1 "Mobile Station (MS) conformance specification; Part 1: Conformance specification"

List of commands

[:SOURCE<hw>]:BB:GNSS:ADGeneration:ACQuisition:CREate.....	602
[:SOURCE<hw>]:BB:GNSS:ADGeneration:ALManac:CREate.....	603
[:SOURCE<hw>]:BB:GNSS:ADGeneration:BEIDou:SVID<ch>:STATe.....	599
[:SOURCE<hw>]:BB:GNSS:ADGeneration:BEIDou:SYNChronize.....	598
[:SOURCE<hw>]:BB:GNSS:ADGeneration:BEIDou:TOAData:DATE?.....	599
[:SOURCE<hw>]:BB:GNSS:ADGeneration:BEIDou:TOAData:DURation.....	601
[:SOURCE<hw>]:BB:GNSS:ADGeneration:BEIDou:TOAData:RESolution.....	601
[:SOURCE<hw>]:BB:GNSS:ADGeneration:BEIDou:TOAData:TBASis?.....	599
[:SOURCE<hw>]:BB:GNSS:ADGeneration:BEIDou:TOAData:TIME?.....	600
[:SOURCE<hw>]:BB:GNSS:ADGeneration:BEIDou:TOAData:TOWeek?.....	601
[:SOURCE<hw>]:BB:GNSS:ADGeneration:BEIDou:TOAData:WNUMber?.....	602
[:SOURCE<hw>]:BB:GNSS:ADGeneration:GALileo:SVID<ch>:STATe.....	599
[:SOURCE<hw>]:BB:GNSS:ADGeneration:GALileo:SYNChronize.....	598
[:SOURCE<hw>]:BB:GNSS:ADGeneration:GALileo:TOAData:DATE?.....	600
[:SOURCE<hw>]:BB:GNSS:ADGeneration:GALileo:TOAData:DURation.....	601
[:SOURCE<hw>]:BB:GNSS:ADGeneration:GALileo:TOAData:RESolution.....	601
[:SOURCE<hw>]:BB:GNSS:ADGeneration:GALileo:TOAData:TBASis?.....	599
[:SOURCE<hw>]:BB:GNSS:ADGeneration:GALileo:TOAData:TIME?.....	600
[:SOURCE<hw>]:BB:GNSS:ADGeneration:GALileo:TOAData:TOWeek?.....	602
[:SOURCE<hw>]:BB:GNSS:ADGeneration:GALileo:TOAData:WNUMber?.....	602
[:SOURCE<hw>]:BB:GNSS:ADGeneration:GLONass:SVID<ch>:STATe.....	599
[:SOURCE<hw>]:BB:GNSS:ADGeneration:GLONass:SYNChronize.....	598
[:SOURCE<hw>]:BB:GNSS:ADGeneration:GLONass:TOAData:DATE?.....	599
[:SOURCE<hw>]:BB:GNSS:ADGeneration:GLONass:TOAData:DURation.....	601
[:SOURCE<hw>]:BB:GNSS:ADGeneration:GLONass:TOAData:RESolution.....	601
[:SOURCE<hw>]:BB:GNSS:ADGeneration:GLONass:TOAData:TBASis?.....	599
[:SOURCE<hw>]:BB:GNSS:ADGeneration:GLONass:TOAData:TIME?.....	600
[:SOURCE<hw>]:BB:GNSS:ADGeneration:GLONass:TOAData:TOWeek?.....	601
[:SOURCE<hw>]:BB:GNSS:ADGeneration:GLONass:TOAData:WNUMber?.....	602
[:SOURCE<hw>]:BB:GNSS:ADGeneration:GPS:SVID<ch>:STATe.....	599
[:SOURCE<hw>]:BB:GNSS:ADGeneration:GPS:SYNChronize.....	598
[:SOURCE<hw>]:BB:GNSS:ADGeneration:GPS:TOAData:DATE?.....	600
[:SOURCE<hw>]:BB:GNSS:ADGeneration:GPS:TOAData:DURation.....	601
[:SOURCE<hw>]:BB:GNSS:ADGeneration:GPS:TOAData:RESolution.....	601
[:SOURCE<hw>]:BB:GNSS:ADGeneration:GPS:TOAData:TBASis?.....	599
[:SOURCE<hw>]:BB:GNSS:ADGeneration:GPS:TOAData:TIME?.....	600
[:SOURCE<hw>]:BB:GNSS:ADGeneration:GPS:TOAData:TOWeek?.....	602
[:SOURCE<hw>]:BB:GNSS:ADGeneration:GPS:TOAData:WNUMber?.....	602
[:SOURCE<hw>]:BB:GNSS:ADGeneration:MODE.....	598
[:SOURCE<hw>]:BB:GNSS:ADGeneration:NAVIC:SVID<ch>:STATe.....	599
[:SOURCE<hw>]:BB:GNSS:ADGeneration:NAVIC:SYNChronize.....	598
[:SOURCE<hw>]:BB:GNSS:ADGeneration:NAVIC:TOAData:DATE?.....	599
[:SOURCE<hw>]:BB:GNSS:ADGeneration:NAVIC:TOAData:DURation.....	601
[:SOURCE<hw>]:BB:GNSS:ADGeneration:NAVIC:TOAData:RESolution.....	601
[:SOURCE<hw>]:BB:GNSS:ADGeneration:NAVIC:TOAData:TBASis?.....	599
[:SOURCE<hw>]:BB:GNSS:ADGeneration:NAVIC:TOAData:TIME?.....	600
[:SOURCE<hw>]:BB:GNSS:ADGeneration:NAVIC:TOAData:TOWeek?.....	601

[:SOURCE<hw>]:BB:GNSS:ADGeneration:NAVIC:TOADData:WNUMber?	602
[:SOURCE<hw>]:BB:GNSS:ADGeneration:NAVigation:CREate	603
[:SOURCE<hw>]:BB:GNSS:ADGeneration:NAVigation:DFORmat	599
[:SOURCE<hw>]:BB:GNSS:ADGeneration:QZSS:SVID<ch>:STATe	599
[:SOURCE<hw>]:BB:GNSS:ADGeneration:QZSS:SYNChronize	598
[:SOURCE<hw>]:BB:GNSS:ADGeneration:QZSS:TOADData:DATE?	599
[:SOURCE<hw>]:BB:GNSS:ADGeneration:QZSS:TOADData:DURation	601
[:SOURCE<hw>]:BB:GNSS:ADGeneration:QZSS:TOADData:RESolution	601
[:SOURCE<hw>]:BB:GNSS:ADGeneration:QZSS:TOADData:TBASis?	599
[:SOURCE<hw>]:BB:GNSS:ADGeneration:QZSS:TOADData:TIME?	600
[:SOURCE<hw>]:BB:GNSS:ADGeneration:QZSS:TOADData:TOWeek?	601
[:SOURCE<hw>]:BB:GNSS:ADGeneration:QZSS:TOADData:WNUMber?	602
[:SOURCE<hw>]:BB:GNSS:APATtern:CATalog:PREDeFined?	391
[:SOURCE<hw>]:BB:GNSS:APATtern:CATalog:USER?	391
[:SOURCE<hw>]:BB:GNSS:ATMospheric:BEIDou:NMESSage:CNAV:IONospheric:ALPHa<ch0>	564
[:SOURCE<hw>]:BB:GNSS:ATMospheric:BEIDou:NMESSage:CNAV:IONospheric:ALPHa<ch0>: UNSCaled	564
[:SOURCE<hw>]:BB:GNSS:ATMospheric:BEIDou:NMESSage:CNAV:IONospheric:BETA<ch0>	565
[:SOURCE<hw>]:BB:GNSS:ATMospheric:BEIDou:NMESSage:CNAV:IONospheric:BETA<ch0>:UNSCaled	565
[:SOURCE<hw>]:BB:GNSS:ATMospheric:BEIDou:NMESSage:DNAV:IONospheric:ALPHa<ch0>	564
[:SOURCE<hw>]:BB:GNSS:ATMospheric:BEIDou:NMESSage:DNAV:IONospheric:ALPHa<ch0>: UNSCaled	564
[:SOURCE<hw>]:BB:GNSS:ATMospheric:BEIDou:NMESSage:DNAV:IONospheric:BETA<ch0>	565
[:SOURCE<hw>]:BB:GNSS:ATMospheric:BEIDou:NMESSage:DNAV:IONospheric:BETA<ch0>:UNSCaled	565
[:SOURCE<hw>]:BB:GNSS:ATMospheric:GALileo:NMESSage:FNAV:IONospheric:Al<ch0>	564
[:SOURCE<hw>]:BB:GNSS:ATMospheric:GALileo:NMESSage:FNAV:IONospheric:Al<ch0>:UNSCaled	564
[:SOURCE<hw>]:BB:GNSS:ATMospheric:GALileo:NMESSage:FNAV:IONospheric:SF<ch>	566
[:SOURCE<hw>]:BB:GNSS:ATMospheric:GALileo:NMESSage:INAV:IONospheric:Al<ch0>	564
[:SOURCE<hw>]:BB:GNSS:ATMospheric:GALileo:NMESSage:INAV:IONospheric:Al<ch0>:UNSCaled	564
[:SOURCE<hw>]:BB:GNSS:ATMospheric:GALileo:NMESSage:INAV:IONospheric:SF<ch>	566
[:SOURCE<hw>]:BB:GNSS:ATMospheric:GPS:NMESSage:CNAV:IONospheric:ALPHa<ch0>	564
[:SOURCE<hw>]:BB:GNSS:ATMospheric:GPS:NMESSage:CNAV:IONospheric:ALPHa<ch0>:UNSCaled	564
[:SOURCE<hw>]:BB:GNSS:ATMospheric:GPS:NMESSage:CNAV:IONospheric:BETA<ch0>	565
[:SOURCE<hw>]:BB:GNSS:ATMospheric:GPS:NMESSage:CNAV:IONospheric:BETA<ch0>:UNSCaled	565
[:SOURCE<hw>]:BB:GNSS:ATMospheric:GPS:NMESSage:LNAV:IONospheric:ALPHa<ch0>	564
[:SOURCE<hw>]:BB:GNSS:ATMospheric:GPS:NMESSage:LNAV:IONospheric:ALPHa<ch0>:UNSCaled	564
[:SOURCE<hw>]:BB:GNSS:ATMospheric:GPS:NMESSage:LNAV:IONospheric:BETA<ch0>	565
[:SOURCE<hw>]:BB:GNSS:ATMospheric:GPS:NMESSage:LNAV:IONospheric:BETA<ch0>:UNSCaled	565
[:SOURCE<hw>]:BB:GNSS:ATMospheric:IONospheric:KLOBuchar:ALPHa<ch0>:UNSCaled	433
[:SOURCE<hw>]:BB:GNSS:ATMospheric:IONospheric:KLOBuchar:BETA<ch0>:UNSCaled	434
[:SOURCE<hw>]:BB:GNSS:ATMospheric:IONospheric:MODEl	430
[:SOURCE<hw>]:BB:GNSS:ATMospheric:IONospheric:MOPS:DISPlay	431
[:SOURCE<hw>]:BB:GNSS:ATMospheric:IONospheric:MOPS:EXPort	432
[:SOURCE<hw>]:BB:GNSS:ATMospheric:IONospheric:MOPS:FILE	431
[:SOURCE<hw>]:BB:GNSS:ATMospheric:IONospheric:MOPS:IMPort:ADD:DIR	432
[:SOURCE<hw>]:BB:GNSS:ATMospheric:IONospheric:MOPS:IMPort:ADD:FILE:EMS	432
[:SOURCE<hw>]:BB:GNSS:ATMospheric:IONospheric:MOPS:IMPort:ADD:FILE:GRID	432
[:SOURCE<hw>]:BB:GNSS:ATMospheric:IONospheric:MOPS:IMPort:ADD:FILE:NSTB	432
[:SOURCE<hw>]:BB:GNSS:ATMospheric:IONospheric:MOPS:IMPort:EXECute	433
[:SOURCE<hw>]:BB:GNSS:ATMospheric:IONospheric:MOPS:IMPort:LIST?	433

[:SOURCE<hw>]:BB:GNSS:ATMospheric:IONospheric:MOPS:IMPort:REMove:ALL.....	433
[:SOURCE<hw>]:BB:GNSS:ATMospheric:IONospheric:MOPS:IMPort:REMove:FILE<ch>.....	433
[:SOURCE<hw>]:BB:GNSS:ATMospheric:IONospheric:NEQuick:SFLux.....	430
[:SOURCE<hw>]:BB:GNSS:ATMospheric:IONospheric:NEQuick:SUNSpot.....	430
[:SOURCE<hw>]:BB:GNSS:ATMospheric:IONospheric:NEQuick:UMSN.....	431
[:SOURCE<hw>]:BB:GNSS:ATMospheric:NAVic:NMEssage:NAV:IONospheric:ALPHA<ch0>.....	564
[:SOURCE<hw>]:BB:GNSS:ATMospheric:NAVic:NMEssage:NAV:IONospheric:ALPHA<ch0>:UNSCaled..	564
[:SOURCE<hw>]:BB:GNSS:ATMospheric:NAVic:NMEssage:NAV:IONospheric:BETA<ch0>.....	565
[:SOURCE<hw>]:BB:GNSS:ATMospheric:NAVic:NMEssage:NAV:IONospheric:BETA<ch0>:UNSCaled....	565
[:SOURCE<hw>]:BB:GNSS:ATMospheric:QZSS:NMEssage:CNAV:IONospheric:ALPHA<ch0>.....	564
[:SOURCE<hw>]:BB:GNSS:ATMospheric:QZSS:NMEssage:CNAV:IONospheric:ALPHA<ch0>:UNSCaled	564
[:SOURCE<hw>]:BB:GNSS:ATMospheric:QZSS:NMEssage:CNAV:IONospheric:BETA<ch0>.....	565
[:SOURCE<hw>]:BB:GNSS:ATMospheric:QZSS:NMEssage:CNAV:IONospheric:BETA<ch0>:UNSCaled..	565
[:SOURCE<hw>]:BB:GNSS:ATMospheric:QZSS:NMEssage:NAV:IONospheric:ALPHA<ch0>.....	564
[:SOURCE<hw>]:BB:GNSS:ATMospheric:QZSS:NMEssage:NAV:IONospheric:ALPHA<ch0>:UNSCaled..	564
[:SOURCE<hw>]:BB:GNSS:ATMospheric:QZSS:NMEssage:NAV:IONospheric:BETA<ch0>.....	565
[:SOURCE<hw>]:BB:GNSS:ATMospheric:QZSS:NMEssage:NAV:IONospheric:BETA<ch0>:UNSCaled....	565
[:SOURCE<hw>]:BB:GNSS:ATMospheric:TROPospheric:MODEl.....	430
[:SOURCE<hw>]:BB:GNSS:AWGN[:RF<ch>]:BWIDTH.....	435
[:SOURCE<hw>]:BB:GNSS:AWGN[:RF<ch>]:CNDRatio.....	435
[:SOURCE<hw>]:BB:GNSS:AWGN[:RF<ch>]:CONFig.....	435
[:SOURCE<hw>]:BB:GNSS:AWGN[:RF<ch>]:FREQuency:CENTer.....	436
[:SOURCE<hw>]:BB:GNSS:AWGN[:RF<ch>]:FREQuency:CW.....	436
[:SOURCE<hw>]:BB:GNSS:AWGN[:RF<ch>]:FREQuency:REFerence?.....	436
[:SOURCE<hw>]:BB:GNSS:AWGN[:RF<ch>]:FREQuency:TARGet.....	436
[:SOURCE<hw>]:BB:GNSS:AWGN[:RF<ch>]:JSRatio.....	437
[:SOURCE<hw>]:BB:GNSS:AWGN[:RF<ch>]:MODE.....	437
[:SOURCE<hw>]:BB:GNSS:AWGN[:RF<ch>]:STATe.....	437
[:SOURCE<hw>]:BB:GNSS:BODY:CATalog:PREDEfined.....	391
[:SOURCE<hw>]:BB:GNSS:BODY:CATalog:USER.....	391
[:SOURCE<hw>]:BB:GNSS:CFREquency?.....	363
[:SOURCE<hw>]:BB:GNSS:CLOCK:MODE.....	649
[:SOURCE<hw>]:BB:GNSS:CLOCK:SOURce.....	649
[:SOURCE<hw>]:BB:GNSS:GALileo:OSNMa:ADDelay.....	568
[:SOURCE<hw>]:BB:GNSS:GALileo:OSNMa:ADKD.....	568
[:SOURCE<hw>]:BB:GNSS:GALileo:OSNMa:AESKey:LENGth.....	568
[:SOURCE<hw>]:BB:GNSS:GALileo:OSNMa:CKEY:TDURation:SONE.....	569
[:SOURCE<hw>]:BB:GNSS:GALileo:OSNMa:CKEY:TDURation:STWO.....	569
[:SOURCE<hw>]:BB:GNSS:GALileo:OSNMa:HF.....	569
[:SOURCE<hw>]:BB:GNSS:GALileo:OSNMa:KS.....	569
[:SOURCE<hw>]:BB:GNSS:GALileo:OSNMa:MACLt.....	570
[:SOURCE<hw>]:BB:GNSS:GALileo:OSNMa:MF.....	570
[:SOURCE<hw>]:BB:GNSS:GALileo:OSNMa:NPKT.....	570
[:SOURCE<hw>]:BB:GNSS:GALileo:OSNMa:PID.....	571
[:SOURCE<hw>]:BB:GNSS:GALileo:OSNMa:PKEY:NTDay.....	571
[:SOURCE<hw>]:BB:GNSS:GALileo:OSNMa:PKEY:TDURation:SONE.....	571
[:SOURCE<hw>]:BB:GNSS:GALileo:OSNMa:PKEY:TDURation:STWO.....	571
[:SOURCE<hw>]:BB:GNSS:GALileo:OSNMa:PKEY:TOMidnight.....	572
[:SOURCE<hw>]:BB:GNSS:GALileo:OSNMa:RKEY:NTDay.....	572
[:SOURCE<hw>]:BB:GNSS:GALileo:OSNMa:RKEY:TOMidnight.....	572

[:SOURCE<hw>]:BB:GNSS:GALileo:OSNMa:SPReemption.....	573
[:SOURCE<hw>]:BB:GNSS:GALileo:OSNMa:TMODe.....	573
[:SOURCE<hw>]:BB:GNSS:GALileo:OSNMa:TS.....	573
[:SOURCE<hw>]:BB:GNSS:L1Band[:STATe].....	363
[:SOURCE<hw>]:BB:GNSS:L2Band[:STATe].....	363
[:SOURCE<hw>]:BB:GNSS:L5Band[:STATe].....	363
[:SOURCE<hw>]:BB:GNSS:LOGGing:CATegory:SATellite:ACCEleration:ECEF.....	629
[:SOURCE<hw>]:BB:GNSS:LOGGing:CATegory:SATellite:AZIMuth.....	629
[:SOURCE<hw>]:BB:GNSS:LOGGing:CATegory:SATellite:CBias.....	629
[:SOURCE<hw>]:BB:GNSS:LOGGing:CATegory:SATellite:CRANge.....	629
[:SOURCE<hw>]:BB:GNSS:LOGGing:CATegory:SATellite:DSHift.....	629
[:SOURCE<hw>]:BB:GNSS:LOGGing:CATegory:SATellite:ELEVation.....	629
[:SOURCE<hw>]:BB:GNSS:LOGGing:CATegory:SATellite:FORMat?.....	628
[:SOURCE<hw>]:BB:GNSS:LOGGing:CATegory:SATellite:IDELay.....	629
[:SOURCE<hw>]:BB:GNSS:LOGGing:CATegory:SATellite:POSition:ECEF.....	629
[:SOURCE<hw>]:BB:GNSS:LOGGing:CATegory:SATellite:PRANge.....	629
[:SOURCE<hw>]:BB:GNSS:LOGGing:CATegory:SATellite:PRBias.....	629
[:SOURCE<hw>]:BB:GNSS:LOGGing:CATegory:SATellite:PRBRate.....	629
[:SOURCE<hw>]:BB:GNSS:LOGGing:CATegory:SATellite:PRRate.....	629
[:SOURCE<hw>]:BB:GNSS:LOGGing:CATegory:SATellite:RANGe.....	629
[:SOURCE<hw>]:BB:GNSS:LOGGing:CATegory:SATellite:RRATE.....	629
[:SOURCE<hw>]:BB:GNSS:LOGGing:CATegory:SATellite:SELect:ALL.....	628
[:SOURCE<hw>]:BB:GNSS:LOGGing:CATegory:SATellite:SELect:NONE.....	628
[:SOURCE<hw>]:BB:GNSS:LOGGing:CATegory:SATellite:SLEVel.....	629
[:SOURCE<hw>]:BB:GNSS:LOGGing:CATegory:SATellite:STATe.....	628
[:SOURCE<hw>]:BB:GNSS:LOGGing:CATegory:SATellite:STEP.....	628
[:SOURCE<hw>]:BB:GNSS:LOGGing:CATegory:SATellite:TDELay.....	629
[:SOURCE<hw>]:BB:GNSS:LOGGing:CATegory:SATellite:VELocity:ECEF.....	629
[:SOURCE<hw>]:BB:GNSS:LOGGing:CATegory:UMOTion:FORMat?.....	628
[:SOURCE<hw>]:BB:GNSS:LOGGing:CATegory:UMOTion:STATe.....	628
[:SOURCE<hw>]:BB:GNSS:LOGGing:CATegory:UMOTion:STEP.....	628
[:SOURCE<hw>]:BB:GNSS:LOGGing:CATegory:UMOTion[:CSV]:ACCEleration:ECEF.....	629
[:SOURCE<hw>]:BB:GNSS:LOGGing:CATegory:UMOTion[:CSV]:AOFFset.....	629
[:SOURCE<hw>]:BB:GNSS:LOGGing:CATegory:UMOTion[:CSV]:ATTitude.....	629
[:SOURCE<hw>]:BB:GNSS:LOGGing:CATegory:UMOTion[:CSV]:ATTitude:ACCEleration.....	629
[:SOURCE<hw>]:BB:GNSS:LOGGing:CATegory:UMOTion[:CSV]:ATTitude:JERK.....	629
[:SOURCE<hw>]:BB:GNSS:LOGGing:CATegory:UMOTion[:CSV]:ATTitude:RATE.....	629
[:SOURCE<hw>]:BB:GNSS:LOGGing:CATegory:UMOTion[:CSV]:GDOP.....	629
[:SOURCE<hw>]:BB:GNSS:LOGGing:CATegory:UMOTion[:CSV]:GSPeed.....	629
[:SOURCE<hw>]:BB:GNSS:LOGGing:CATegory:UMOTion[:CSV]:HDOP.....	629
[:SOURCE<hw>]:BB:GNSS:LOGGing:CATegory:UMOTion[:CSV]:JERK:ECEF.....	629
[:SOURCE<hw>]:BB:GNSS:LOGGing:CATegory:UMOTion[:CSV]:PDOP.....	629
[:SOURCE<hw>]:BB:GNSS:LOGGing:CATegory:UMOTion[:CSV]:POSition:ECEF.....	629
[:SOURCE<hw>]:BB:GNSS:LOGGing:CATegory:UMOTion[:CSV]:POSition:ENU.....	629
[:SOURCE<hw>]:BB:GNSS:LOGGing:CATegory:UMOTion[:CSV]:POSition:LLA.....	629
[:SOURCE<hw>]:BB:GNSS:LOGGing:CATegory:UMOTion[:CSV]:SELect:ALL.....	628
[:SOURCE<hw>]:BB:GNSS:LOGGing:CATegory:UMOTion[:CSV]:SELect:NONE.....	628
[:SOURCE<hw>]:BB:GNSS:LOGGing:CATegory:UMOTion[:CSV]:SVS.....	629
[:SOURCE<hw>]:BB:GNSS:LOGGing:CATegory:UMOTion[:CSV]:TDOP.....	630
[:SOURCE<hw>]:BB:GNSS:LOGGing:CATegory:UMOTion[:CSV]:VDOP.....	630

[:SOURCE<hw>]:BB:GNSS:LOGGING:CATegory:UMOTion[:CSV]:VELOCITY:ECEF.....	630
[:SOURCE<hw>]:BB:GNSS:LOGGING:CATegory:UMOTion[:CSV]:VELOCITY:LNED.....	630
[:SOURCE<hw>]:BB:GNSS:LOGGING:DESTination:FILE:DIRectory.....	627
[:SOURCE<hw>]:BB:GNSS:LOGGING:DESTination:FILE:TAPPend[:STATe].....	627
[:SOURCE<hw>]:BB:GNSS:LOGGING:MODE.....	626
[:SOURCE<hw>]:BB:GNSS:LOGGING:OFFLine:ABORT.....	626
[:SOURCE<hw>]:BB:GNSS:LOGGING:OFFLine:DUration.....	627
[:SOURCE<hw>]:BB:GNSS:LOGGING:OFFLine:GENerate.....	626
[:SOURCE<hw>]:BB:GNSS:LOGGING:OFFLine:PROGress?.....	627
[:SOURCE<hw>]:BB:GNSS:LOGGING:OFFLine:TOFFset.....	626
[:SOURCE<hw>]:BB:GNSS:LOGGING:RT:STATe.....	626
[:SOURCE<hw>]:BB:GNSS:MONitor<ch>:DISPlay.....	607
[:SOURCE<hw>]:BB:GNSS:MONitor<ch>:DISPlay:ANTenna.....	608
[:SOURCE<hw>]:BB:GNSS:MONitor<ch>:DISPlay:CHANnels:ALLocated?.....	611
[:SOURCE<hw>]:BB:GNSS:MONitor<ch>:DISPlay:CHANnels:USED?.....	612
[:SOURCE<hw>]:BB:GNSS:MONitor<ch>:DISPlay:MAP:AXIS.....	608
[:SOURCE<hw>]:BB:GNSS:MONitor<ch>:DISPlay:POWER:ECHoes.....	609
[:SOURCE<hw>]:BB:GNSS:MONitor<ch>:DISPlay:POWER:SYSTem:BEIDou:SIGNal:L1Band:B1C.....	610
[:SOURCE<hw>]:BB:GNSS:MONitor<ch>:DISPlay:POWER:SYSTem:BEIDou:SIGNal:L1Band:B1L.....	610
[:SOURCE<hw>]:BB:GNSS:MONitor<ch>:DISPlay:POWER:SYSTem:BEIDou:SIGNal:L2Band:B3L.....	610
[:SOURCE<hw>]:BB:GNSS:MONitor<ch>:DISPlay:POWER:SYSTem:BEIDou:SIGNal:L5Band:B2A.....	610
[:SOURCE<hw>]:BB:GNSS:MONitor<ch>:DISPlay:POWER:SYSTem:BEIDou:SIGNal:L5Band:B2B.....	610
[:SOURCE<hw>]:BB:GNSS:MONitor<ch>:DISPlay:POWER:SYSTem:BEIDou:SIGNal:L5Band:B2L.....	610
[:SOURCE<hw>]:BB:GNSS:MONitor<ch>:DISPlay:POWER:SYSTem:GALileo:SIGNal:L1Band:E1OS.....	610
[:SOURCE<hw>]:BB:GNSS:MONitor<ch>:DISPlay:POWER:SYSTem:GALileo:SIGNal:L1Band:E1PRs.....	610
[:SOURCE<hw>]:BB:GNSS:MONitor<ch>:DISPlay:POWER:SYSTem:GALileo:SIGNal:L2Band:E6PRs.....	610
[:SOURCE<hw>]:BB:GNSS:MONitor<ch>:DISPlay:POWER:SYSTem:GALileo:SIGNal:L2Band:E6S.....	610
[:SOURCE<hw>]:BB:GNSS:MONitor<ch>:DISPlay:POWER:SYSTem:GALileo:SIGNal:L5Band:E5A.....	610
[:SOURCE<hw>]:BB:GNSS:MONitor<ch>:DISPlay:POWER:SYSTem:GALileo:SIGNal:L5Band:E5B.....	610
[:SOURCE<hw>]:BB:GNSS:MONitor<ch>:DISPlay:POWER:SYSTem:GLONass:SIGNal:L1Band:CA.....	610
[:SOURCE<hw>]:BB:GNSS:MONitor<ch>:DISPlay:POWER:SYSTem:GLONass:SIGNal:L1Band:L1CDma.....	610
[:SOURCE<hw>]:BB:GNSS:MONitor<ch>:DISPlay:POWER:SYSTem:GLONass:SIGNal:L2Band:CA.....	610
[:SOURCE<hw>]:BB:GNSS:MONitor<ch>:DISPlay:POWER:SYSTem:GLONass:SIGNal:L2Band:L2CDma.....	610
[:SOURCE<hw>]:BB:GNSS:MONitor<ch>:DISPlay:POWER:SYSTem:GLONass:SIGNal:L5Band:L3CDma.....	610
[:SOURCE<hw>]:BB:GNSS:MONitor<ch>:DISPlay:POWER:SYSTem:GPS:SIGNal:L1Band:CA.....	611
[:SOURCE<hw>]:BB:GNSS:MONitor<ch>:DISPlay:POWER:SYSTem:GPS:SIGNal:L1Band:L1C.....	611
[:SOURCE<hw>]:BB:GNSS:MONitor<ch>:DISPlay:POWER:SYSTem:GPS:SIGNal:L1Band:M.....	611
[:SOURCE<hw>]:BB:GNSS:MONitor<ch>:DISPlay:POWER:SYSTem:GPS:SIGNal:L1Band:P.....	611
[:SOURCE<hw>]:BB:GNSS:MONitor<ch>:DISPlay:POWER:SYSTem:GPS:SIGNal:L1Band:PY.....	611
[:SOURCE<hw>]:BB:GNSS:MONitor<ch>:DISPlay:POWER:SYSTem:GPS:SIGNal:L2Band:CA.....	611
[:SOURCE<hw>]:BB:GNSS:MONitor<ch>:DISPlay:POWER:SYSTem:GPS:SIGNal:L2Band:L2C.....	611
[:SOURCE<hw>]:BB:GNSS:MONitor<ch>:DISPlay:POWER:SYSTem:GPS:SIGNal:L2Band:M.....	611
[:SOURCE<hw>]:BB:GNSS:MONitor<ch>:DISPlay:POWER:SYSTem:GPS:SIGNal:L2Band:P.....	611
[:SOURCE<hw>]:BB:GNSS:MONitor<ch>:DISPlay:POWER:SYSTem:GPS:SIGNal:L2Band:PY.....	611
[:SOURCE<hw>]:BB:GNSS:MONitor<ch>:DISPlay:POWER:SYSTem:GPS:SIGNal:L5Band:L5S.....	611
[:SOURCE<hw>]:BB:GNSS:MONitor<ch>:DISPlay:POWER:SYSTem:NAVic:SIGNal:L5Band:SPS.....	610
[:SOURCE<hw>]:BB:GNSS:MONitor<ch>:DISPlay:POWER:SYSTem:QZSS:SIGNal:L1Band:CA.....	610
[:SOURCE<hw>]:BB:GNSS:MONitor<ch>:DISPlay:POWER:SYSTem:QZSS:SIGNal:L1Band:L1C.....	610
[:SOURCE<hw>]:BB:GNSS:MONitor<ch>:DISPlay:POWER:SYSTem:QZSS:SIGNal:L2Band:L2C.....	610
[:SOURCE<hw>]:BB:GNSS:MONitor<ch>:DISPlay:POWER:SYSTem:QZSS:SIGNal:L5Band:L5S.....	610

[:SOURCE<hw>]:BB:GNSS:MONitor<ch>:DISPlay:POWer:SYSTem:SBAS:SIGNAL:L1Band:CA.....	610
[:SOURCE<hw>]:BB:GNSS:MONitor<ch>:DISPlay:POWer:SYSTem:SBAS:SIGNAL:L5Band:EL5S.....	610
[:SOURCE<hw>]:BB:GNSS:MONitor<ch>:DISPlay:STReam.....	611
[:SOURCE<hw>]:BB:GNSS:MONitor<ch>:DISPlay:TRACks:SHOW.....	608
[:SOURCE<hw>]:BB:GNSS:MONitor<ch>:DISPlay:TRAJectory:SVID.....	608
[:SOURCE<hw>]:BB:GNSS:MONitor<ch>:DISPlay:TRAJectory:SYSTem.....	609
[:SOURCE<hw>]:BB:GNSS:MONitor<ch>:DISPlay:VEHicle.....	607
[:SOURCE<hw>]:BB:GNSS:OBSCuration:LMM:CATalog:PREDeFined?.....	407
[:SOURCE<hw>]:BB:GNSS:OBSCuration:LMM:CATalog:USER?.....	407
[:SOURCE<hw>]:BB:GNSS:OBSCuration:RPL:CATalog:PREDeFined?.....	407
[:SOURCE<hw>]:BB:GNSS:OBSCuration:RPL:CATalog:USER?.....	407
[:SOURCE<hw>]:BB:GNSS:OBSCuration:VOBS:CATalog:PREDeFined?.....	407
[:SOURCE<hw>]:BB:GNSS:OBSCuration:VOBS:CATalog:USER?.....	407
[:SOURCE<hw>]:BB:GNSS:OSTReams:CONFLict?.....	635
[:SOURCE<hw>]:BB:GNSS:OSTReams:COUNt.....	635
[:SOURCE<hw>]:BB:GNSS:OSTReams:LOCK.....	635
[:SOURCE<hw>]:BB:GNSS:OSTReams:OUTPut:RESet.....	635
[:SOURCE<hw>]:BB:GNSS:PERRors:CATalog.....	493
[:SOURCE<hw>]:BB:GNSS:POWer:REFerence.....	459
[:SOURCE<hw>]:BB:GNSS:PRESet.....	357
[:SOURCE<hw>]:BB:GNSS:RECEiver[V<st>]:A<ch>:APATern:FILE.....	392
[:SOURCE<hw>]:BB:GNSS:RECEiver[V<st>]:A<ch>:BODY:FILE.....	392
[:SOURCE<hw>]:BB:GNSS:RECEiver[V<st>]:A<ch>:DBANK.....	392
[:SOURCE<hw>]:BB:GNSS:RECEiver[V<st>]:A<ch>:DELevation.....	392
[:SOURCE<hw>]:BB:GNSS:RECEiver[V<st>]:A<ch>:DHEading.....	392
[:SOURCE<hw>]:BB:GNSS:RECEiver[V<st>]:A<ch>:DX.....	393
[:SOURCE<hw>]:BB:GNSS:RECEiver[V<st>]:A<ch>:DY.....	393
[:SOURCE<hw>]:BB:GNSS:RECEiver[V<st>]:A<ch>:DZ.....	393
[:SOURCE<hw>]:BB:GNSS:RECEiver[V<st>]:A<ch>:STATE.....	392
[:SOURCE<hw>]:BB:GNSS:RECEiver[V<st>]:ANTenna:COUNt.....	390
[:SOURCE<hw>]:BB:GNSS:RECEiver[V<st>]:ANTenna:DISPlay.....	391
[:SOURCE<hw>]:BB:GNSS:RECEiver[V<st>]:ANTenna:V3D.....	391
[:SOURCE<hw>]:BB:GNSS:RECEiver[V<st>]:ATTitude:PITCh.....	386
[:SOURCE<hw>]:BB:GNSS:RECEiver[V<st>]:ATTitude:ROLL.....	387
[:SOURCE<hw>]:BB:GNSS:RECEiver[V<st>]:ATTitude:SPIN:RATE.....	387
[:SOURCE<hw>]:BB:GNSS:RECEiver[V<st>]:ATTitude:YAW.....	386
[:SOURCE<hw>]:BB:GNSS:RECEiver[V<st>]:ATTitude[BEHaviour].....	386
[:SOURCE<hw>]:BB:GNSS:RECEiver[V<st>]:ENVironment:FULL:AREA:APPend.....	411
[:SOURCE<hw>]:BB:GNSS:RECEiver[V<st>]:ENVironment:FULL:AREA:COUNt?.....	410
[:SOURCE<hw>]:BB:GNSS:RECEiver[V<st>]:ENVironment:FULL:AREA<ch>:DELeTe.....	411
[:SOURCE<hw>]:BB:GNSS:RECEiver[V<st>]:ENVironment:FULL:AREA<ch>:INSert.....	411
[:SOURCE<hw>]:BB:GNSS:RECEiver[V<st>]:ENVironment:FULL:AREA<ch>:LENGth.....	411
[:SOURCE<hw>]:BB:GNSS:RECEiver[V<st>]:ENVironment:FULL:AREA<ch>:REFerence.....	411
[:SOURCE<hw>]:BB:GNSS:RECEiver[V<st>]:ENVironment:FULL:PREDeFined.....	406
[:SOURCE<hw>]:BB:GNSS:RECEiver[V<st>]:ENVironment:FULL:RWINDow.....	410
[:SOURCE<hw>]:BB:GNSS:RECEiver[V<st>]:ENVironment:FULL:RWINDow:STATE.....	410
[:SOURCE<hw>]:BB:GNSS:RECEiver[V<st>]:ENVironment:FULL:RWINDow:STRajectory.....	410
[:SOURCE<hw>]:BB:GNSS:RECEiver[V<st>]:ENVironment:FULL:SCALE.....	409
[:SOURCE<hw>]:BB:GNSS:RECEiver[V<st>]:ENVironment:GSR:CONDUCTivity.....	413
[:SOURCE<hw>]:BB:GNSS:RECEiver[V<st>]:ENVironment:GSR:GALTitude.....	414

[SOURce<hw>]:BB:GNSS:RECeiver[V<st>]:ENVironment:GSR:MPROperty.....	412
[SOURce<hw>]:BB:GNSS:RECeiver[V<st>]:ENVironment:GSR:O1Distance.....	413
[SOURce<hw>]:BB:GNSS:RECeiver[V<st>]:ENVironment:GSR:O1Height.....	414
[SOURce<hw>]:BB:GNSS:RECeiver[V<st>]:ENVironment:GSR:O2Distance.....	413
[SOURce<hw>]:BB:GNSS:RECeiver[V<st>]:ENVironment:GSR:O2Height.....	414
[SOURce<hw>]:BB:GNSS:RECeiver[V<st>]:ENVironment:GSR:OORientation.....	414
[SOURce<hw>]:BB:GNSS:RECeiver[V<st>]:ENVironment:GSR:PERMittivity.....	412
[SOURce<hw>]:BB:GNSS:RECeiver[V<st>]:ENVironment:GSR:PLOSSs.....	413
[SOURce<hw>]:BB:GNSS:RECeiver[V<st>]:ENVironment:GSR:STYPe.....	412
[SOURce<hw>]:BB:GNSS:RECeiver[V<st>]:ENVironment:LMM:FILE.....	407
[SOURce<hw>]:BB:GNSS:RECeiver[V<st>]:ENVironment:MPATH:COPY:EXECute.....	421
[SOURce<hw>]:BB:GNSS:RECeiver[V<st>]:ENVironment:MPATH:COPY:SVID.....	420
[SOURce<hw>]:BB:GNSS:RECeiver[V<st>]:ENVironment:MPATH:COPY:SYSTem.....	420
[SOURce<hw>]:BB:GNSS:RECeiver[V<st>]:ENVironment:MPATH:SVID.....	419
[SOURce<hw>]:BB:GNSS:RECeiver[V<st>]:ENVironment:MPATH:SYSTem.....	419
[SOURce<hw>]:BB:GNSS:RECeiver[V<st>]:ENVironment:PMODEl.....	404
[SOURce<hw>]:BB:GNSS:RECeiver[V<st>]:ENVironment:PREDeFined.....	406
[SOURce<hw>]:BB:GNSS:RECeiver[V<st>]:ENVironment:RPL:DISPLAy.....	409
[SOURce<hw>]:BB:GNSS:RECeiver[V<st>]:ENVironment:RPL:FILE.....	407
[SOURce<hw>]:BB:GNSS:RECeiver[V<st>]:ENVironment:RPL:ILENght.....	409
[SOURce<hw>]:BB:GNSS:RECeiver[V<st>]:ENVironment:RPL:PMODEl.....	404
[SOURce<hw>]:BB:GNSS:RECeiver[V<st>]:ENVironment:RPL:PREDeFined.....	406
[SOURce<hw>]:BB:GNSS:RECeiver[V<st>]:ENVironment:RPL:ROFFset:HEIGHt.....	408
[SOURce<hw>]:BB:GNSS:RECeiver[V<st>]:ENVironment:RPL:RWINDow.....	408
[SOURce<hw>]:BB:GNSS:RECeiver[V<st>]:ENVironment:RPL:RWINDow:STATe.....	408
[SOURce<hw>]:BB:GNSS:RECeiver[V<st>]:ENVironment:RPL:RWINDow:STRajectory.....	409
[SOURce<hw>]:BB:GNSS:RECeiver[V<st>]:ENVironment:VOBS:FILE.....	407
[SOURce<hw>]:BB:GNSS:RECeiver[V<st>]:ENVironment:VOBS:MOrientatIon.....	406
[SOURce<hw>]:BB:GNSS:RECeiver[V<st>]:ENVironment:VOBS:PMODEl.....	404
[SOURce<hw>]:BB:GNSS:RECeiver[V<st>]:ENVironment:VOBS:PREDeFined.....	406
[SOURce<hw>]:BB:GNSS:RECeiver[V<st>]:ENVironment:VOBS:ROFFset:HEIGHt.....	405
[SOURce<hw>]:BB:GNSS:RECeiver[V<st>]:ENVironment:VOBS:ROFFset:X.....	405
[SOURce<hw>]:BB:GNSS:RECeiver[V<st>]:ENVironment:VOBS:ROFFset:Y.....	405
[SOURce<hw>]:BB:GNSS:RECeiver[V<st>]:ENVironment[.MODEl].....	418
[SOURce<hw>]:BB:GNSS:RECeiver[V<st>]:HIL:ITYPe.....	336
[SOURce<hw>]:BB:GNSS:RECeiver[V<st>]:HIL:PORT.....	336
[SOURce<hw>]:BB:GNSS:RECeiver[V<st>]:HIL:SLATency.....	335
[SOURce<hw>]:BB:GNSS:RECeiver[V<st>]:LOCation:CATalog.....	382
[SOURce<hw>]:BB:GNSS:RECeiver[V<st>]:LOCation:COORDinates:DECimal:PZ.....	384
[SOURce<hw>]:BB:GNSS:RECeiver[V<st>]:LOCation:COORDinates:DECimal[.WGS].....	384
[SOURce<hw>]:BB:GNSS:RECeiver[V<st>]:LOCation:COORDinates:DMS:PZ.....	384
[SOURce<hw>]:BB:GNSS:RECeiver[V<st>]:LOCation:COORDinates:DMS[.WGS].....	384
[SOURce<hw>]:BB:GNSS:RECeiver[V<st>]:LOCation:COORDinates:FORMat.....	383
[SOURce<hw>]:BB:GNSS:RECeiver[V<st>]:LOCation:COORDinates:RFRame.....	383
[SOURce<hw>]:BB:GNSS:RECeiver[V<st>]:LOCation:SMOVement.....	388
[SOURce<hw>]:BB:GNSS:RECeiver[V<st>]:LOCation:VEHicle:FILE.....	389
[SOURce<hw>]:BB:GNSS:RECeiver[V<st>]:LOCation:WAYPoints:DURation.....	387
[SOURce<hw>]:BB:GNSS:RECeiver[V<st>]:LOCation:WAYPoints:FILE.....	387
[SOURce<hw>]:BB:GNSS:RECeiver[V<st>]:LOCation:WAYPoints:LENGth?.....	388
[SOURce<hw>]:BB:GNSS:RECeiver[V<st>]:LOCation:WAYPoints:ROMode.....	388

[:SOURCE<hw>]:BB:GNSS:RECEIVER[V<st>]:LOCATION[SELECT].....	383
[:SOURCE<hw>]:BB:GNSS:RECEIVER[V<st>]:POSITION.....	382
[:SOURCE<hw>]:BB:GNSS:RT:BEIDOU:SVID<ch>:AZIMUTH?.....	614
[:SOURCE<hw>]:BB:GNSS:RT:BEIDOU:SVID<ch>:ELEVATION?.....	615
[:SOURCE<hw>]:BB:GNSS:RT:GALILEO:SVID<ch>:AZIMUTH?.....	614
[:SOURCE<hw>]:BB:GNSS:RT:GALILEO:SVID<ch>:ELEVATION?.....	615
[:SOURCE<hw>]:BB:GNSS:RT:GLONASS:SVID<ch>:AZIMUTH?.....	614
[:SOURCE<hw>]:BB:GNSS:RT:GLONASS:SVID<ch>:ELEVATION?.....	615
[:SOURCE<hw>]:BB:GNSS:RT:GPS:SVID<ch>:AZIMUTH?.....	614
[:SOURCE<hw>]:BB:GNSS:RT:GPS:SVID<ch>:ELEVATION?.....	615
[:SOURCE<hw>]:BB:GNSS:RT:HDOP?.....	616
[:SOURCE<hw>]:BB:GNSS:RT:HWTIME?.....	336
[:SOURCE<hw>]:BB:GNSS:RT:NAVIC:SVID<ch>:AZIMUTH?.....	614
[:SOURCE<hw>]:BB:GNSS:RT:NAVIC:SVID<ch>:ELEVATION?.....	615
[:SOURCE<hw>]:BB:GNSS:RT:PDOP?.....	617
[:SOURCE<hw>]:BB:GNSS:RT:QZSS:SVID<ch>:AZIMUTH?.....	614
[:SOURCE<hw>]:BB:GNSS:RT:QZSS:SVID<ch>:ELEVATION?.....	615
[:SOURCE<hw>]:BB:GNSS:RT:RASTITUDE?.....	620
[:SOURCE<hw>]:BB:GNSS:RT:RECEIVER[V<st>]:HILPOSITION:LATENCY:STATISTICS?.....	333
[:SOURCE<hw>]:BB:GNSS:RT:RECEIVER[V<st>]:HILPOSITION:LATENCY?.....	333
[:SOURCE<hw>]:BB:GNSS:RT:RECEIVER[V<st>]:HILPOSITION:MODE:A.....	331
[:SOURCE<hw>]:BB:GNSS:RT:RECEIVER[V<st>]:HILPOSITION:MODE:B.....	332
[:SOURCE<hw>]:BB:GNSS:RT:RECEIVER[V<st>]:RLOCATION:COORDINATES:DECIMAL?.....	617
[:SOURCE<hw>]:BB:GNSS:RT:RECEIVER[V<st>]:RLOCATION:COORDINATES:DMS?.....	618
[:SOURCE<hw>]:BB:GNSS:RT:RECEIVER[V<st>]:RVELOCITY?.....	623
[:SOURCE<hw>]:BB:GNSS:RT:RPVT?.....	621
[:SOURCE<hw>]:BB:GNSS:RT:SBAS:SVID<ch>:AZIMUTH?.....	614
[:SOURCE<hw>]:BB:GNSS:RT:SBAS:SVID<ch>:ELEVATION?.....	615
[:SOURCE<hw>]:BB:GNSS:RT:VDOP?.....	617
[:SOURCE<hw>]:BB:GNSS:RT[STREAM<ch>]:ACTIVE:SYSTEMS?.....	613
[:SOURCE<hw>]:BB:GNSS:RT[STREAM<ch>]:BEIDOU:ACTIVE:SIGNALS?.....	613
[:SOURCE<hw>]:BB:GNSS:RT[STREAM<ch>]:GALILEO:ACTIVE:SIGNALS?.....	613
[:SOURCE<hw>]:BB:GNSS:RT[STREAM<ch>]:GLONASS:ACTIVE:SIGNALS?.....	613
[:SOURCE<hw>]:BB:GNSS:RT[STREAM<ch>]:GPS:ACTIVE:SIGNALS?.....	613
[:SOURCE<hw>]:BB:GNSS:RT[STREAM<ch>]:NAVIC:ACTIVE:SIGNALS?.....	613
[:SOURCE<hw>]:BB:GNSS:RT[STREAM<ch>]:QZSS:ACTIVE:SIGNALS?.....	613
[:SOURCE<hw>]:BB:GNSS:RT[STREAM<ch>]:SBAS:ACTIVE:SIGNALS?.....	613
[:SOURCE<hw>]:BB:GNSS:RTK:BASE<st>:A<ch>:APATTERN:FILE.....	399
[:SOURCE<hw>]:BB:GNSS:RTK:BASE<st>:A<ch>:BODY:FILE.....	399
[:SOURCE<hw>]:BB:GNSS:RTK:BASE<st>:A<ch>:DBANK.....	400
[:SOURCE<hw>]:BB:GNSS:RTK:BASE<st>:A<ch>:DELEVATION.....	400
[:SOURCE<hw>]:BB:GNSS:RTK:BASE<st>:A<ch>:DHEADING.....	400
[:SOURCE<hw>]:BB:GNSS:RTK:BASE<st>:A<ch>:DX.....	400
[:SOURCE<hw>]:BB:GNSS:RTK:BASE<st>:A<ch>:DY.....	400
[:SOURCE<hw>]:BB:GNSS:RTK:BASE<st>:A<ch>:DZ.....	400
[:SOURCE<hw>]:BB:GNSS:RTK:BASE<st>:A<ch>:STATE.....	400
[:SOURCE<hw>]:BB:GNSS:RTK:BASE<st>:LOCATION:CATALOG.....	396
[:SOURCE<hw>]:BB:GNSS:RTK:BASE<st>:LOCATION:COORDINATES:DECIMAL:PZ.....	397
[:SOURCE<hw>]:BB:GNSS:RTK:BASE<st>:LOCATION:COORDINATES:DECIMAL[WGS].....	397
[:SOURCE<hw>]:BB:GNSS:RTK:BASE<st>:LOCATION:COORDINATES:DMS:PZ.....	398

[:SOURce<hw>]:BB:GNSS:RTK:BASE<st>:LOCation:COORdinateS:DMS[:WGS]	398
[:SOURce<hw>]:BB:GNSS:RTK:BASE<st>:LOCation:COORdinateS:FORMat	397
[:SOURce<hw>]:BB:GNSS:RTK:BASE<st>:LOCation:COORdinateS:RFFrame	396
[:SOURce<hw>]:BB:GNSS:RTK:BASE<st>:LOCation:SYNC	399
[:SOURce<hw>]:BB:GNSS:RTK:BASE<st>:LOCation[:SELEct]	396
[:SOURce<hw>]:BB:GNSS:RTK:BASE<st>:MOUNtpoint?	395
[:SOURce<hw>]:BB:GNSS:RTK:BSTation:COUNT	395
[:SOURce<hw>]:BB:GNSS:RTK:PASSword?	401
[:SOURce<hw>]:BB:GNSS:RTK:PORT	401
[:SOURce<hw>]:BB:GNSS:RTK:PROTocol	401
[:SOURce<hw>]:BB:GNSS:RTK:STATe	395
[:SOURce<hw>]:BB:GNSS:RTK:USER?	401
[:SOURce<hw>]:BB:GNSS:SCENario?	357
[:SOURce<hw>]:BB:GNSS:SETTing:CATalog:PREDEfined?	360
[:SOURce<hw>]:BB:GNSS:SETTing:CATalog?	359
[:SOURce<hw>]:BB:GNSS:SETTing:DELEte	360
[:SOURce<hw>]:BB:GNSS:SETTing:LOAD	360
[:SOURce<hw>]:BB:GNSS:SETTing:LOAD:PREDEfined	360
[:SOURce<hw>]:BB:GNSS:SETTing:STORe	359
[:SOURce<hw>]:BB:GNSS:SIMulation:INFO?	359
[:SOURce<hw>]:BB:GNSS:SSVAlueS	483
[:SOURce<hw>]:BB:GNSS:STATe	357
[:SOURce<hw>]:BB:GNSS:STReam<st>:ANTenna	636
[:SOURce<hw>]:BB:GNSS:STReam<st>:BB:CHANnelS:ALLocated?	637
[:SOURce<hw>]:BB:GNSS:STReam<st>:BB:COUNT	636
[:SOURce<hw>]:BB:GNSS:STReam<st>:BB:INFO?	636
[:SOURce<hw>]:BB:GNSS:STReam<st>:BB:LIST?	636
[:SOURce<hw>]:BB:GNSS:STReam<st>:CHANnelS:MAX	637
[:SOURce<hw>]:BB:GNSS:STReam<st>:CONFLict?	635
[:SOURce<hw>]:BB:GNSS:STReam<st>:L1Band[:STATe]	637
[:SOURce<hw>]:BB:GNSS:STReam<st>:L2Band[:STATe]	637
[:SOURce<hw>]:BB:GNSS:STReam<st>:L5Band[:STATe]	637
[:SOURce<hw>]:BB:GNSS:STReam<st>:OUTPut	638
[:SOURce<hw>]:BB:GNSS:STReam<st>:OUTPut:BBMM<ch>:STATe	637
[:SOURce<hw>]:BB:GNSS:STReam<st>:OUTPut:RF<ch>:STATe	638
[:SOURce<hw>]:BB:GNSS:STReam<st>:RFBand	638
[:SOURce<hw>]:BB:GNSS:STReam<st>:VEHicle	638
[:SOURce<hw>]:BB:GNSS:SV:BEIDou:NMESsage:CNAV:TIME:CONVerSion:GALileo:AONE	561
[:SOURce<hw>]:BB:GNSS:SV:BEIDou:NMESsage:CNAV:TIME:CONVerSion:GALileo:AONE:UNSCaled	561
[:SOURce<hw>]:BB:GNSS:SV:BEIDou:NMESsage:CNAV:TIME:CONVerSion:GALileo:AZERo	561
[:SOURce<hw>]:BB:GNSS:SV:BEIDou:NMESsage:CNAV:TIME:CONVerSion:GALileo:AZERo:UNSCaled	561
[:SOURce<hw>]:BB:GNSS:SV:BEIDou:NMESsage:CNAV:TIME:CONVerSion:GALileo:TOT	561
[:SOURce<hw>]:BB:GNSS:SV:BEIDou:NMESsage:CNAV:TIME:CONVerSion:GALileo:TOT:UNSCaled	561
[:SOURce<hw>]:BB:GNSS:SV:BEIDou:NMESsage:CNAV:TIME:CONVerSion:GLONass:AONE	563
[:SOURce<hw>]:BB:GNSS:SV:BEIDou:NMESsage:CNAV:TIME:CONVerSion:GLONass:AONE: UNSCaled	563
[:SOURce<hw>]:BB:GNSS:SV:BEIDou:NMESsage:CNAV:TIME:CONVerSion:GLONass:AZERo	563
[:SOURce<hw>]:BB:GNSS:SV:BEIDou:NMESsage:CNAV:TIME:CONVerSion:GLONass:AZERo: UNSCaled	563
[:SOURce<hw>]:BB:GNSS:SV:BEIDou:NMESsage:CNAV:TIME:CONVerSion:GLONass:TOT	562

[:SOURCE<hw>]:BB:GNSS:SV:BEIDou:NMEssage:CNAV:TIME:CONVersion:GLONass:TOT:UNSCaled..	562
[:SOURCE<hw>]:BB:GNSS:SV:BEIDou:NMEssage:CNAV:TIME:CONVersion:GPS:AONE.....	560
[:SOURCE<hw>]:BB:GNSS:SV:BEIDou:NMEssage:CNAV:TIME:CONVersion:GPS:AONE:UNSCaled.....	560
[:SOURCE<hw>]:BB:GNSS:SV:BEIDou:NMEssage:CNAV:TIME:CONVersion:GPS:AZERo.....	559
[:SOURCE<hw>]:BB:GNSS:SV:BEIDou:NMEssage:CNAV:TIME:CONVersion:GPS:AZERo:UNSCaled.....	559
[:SOURCE<hw>]:BB:GNSS:SV:BEIDou:NMEssage:CNAV:TIME:CONVersion:GPS:TOT.....	559
[:SOURCE<hw>]:BB:GNSS:SV:BEIDou:NMEssage:CNAV:TIME:CONVersion:GPS:TOT:UNSCaled.....	558
[:SOURCE<hw>]:BB:GNSS:SV:BEIDou:NMEssage:CNAV:TIME:CONVersion:UTC:AONE.....	556
[:SOURCE<hw>]:BB:GNSS:SV:BEIDou:NMEssage:CNAV:TIME:CONVersion:UTC:AONE:UNSCaled.....	556
[:SOURCE<hw>]:BB:GNSS:SV:BEIDou:NMEssage:CNAV:TIME:CONVersion:UTC:AZERo.....	558
[:SOURCE<hw>]:BB:GNSS:SV:BEIDou:NMEssage:CNAV:TIME:CONVersion:UTC:AZERo:UNSCaled.....	558
[:SOURCE<hw>]:BB:GNSS:SV:BEIDou:NMEssage:CNAV:TIME:CONVersion:UTC:TOT.....	555
[:SOURCE<hw>]:BB:GNSS:SV:BEIDou:NMEssage:CNAV:TIME:CONVersion:UTC:TOT:UNSCaled.....	555
[:SOURCE<hw>]:BB:GNSS:SV:BEIDou:NMEssage:CNAV:TIME:CONVersion:UTC:WNOT.....	554
[:SOURCE<hw>]:BB:GNSS:SV:BEIDou:NMEssage:DNAV:TIME:CONVersion:GALileo:AONE.....	561
[:SOURCE<hw>]:BB:GNSS:SV:BEIDou:NMEssage:DNAV:TIME:CONVersion:GALileo:AONE:UNSCaled.	561
[:SOURCE<hw>]:BB:GNSS:SV:BEIDou:NMEssage:DNAV:TIME:CONVersion:GALileo:AZERo.....	561
[:SOURCE<hw>]:BB:GNSS:SV:BEIDou:NMEssage:DNAV:TIME:CONVersion:GALileo:AZERo:UNSCaled	561
[:SOURCE<hw>]:BB:GNSS:SV:BEIDou:NMEssage:DNAV:TIME:CONVersion:GALileo:TOT.....	561
[:SOURCE<hw>]:BB:GNSS:SV:BEIDou:NMEssage:DNAV:TIME:CONVersion:GALileo:TOT:UNSCaled.....	561
[:SOURCE<hw>]:BB:GNSS:SV:BEIDou:NMEssage:DNAV:TIME:CONVersion:GLONass:AONE.....	563
[:SOURCE<hw>]:BB:GNSS:SV:BEIDou:NMEssage:DNAV:TIME:CONVersion:GLONass:AONE: UNSCaled.....	563
[:SOURCE<hw>]:BB:GNSS:SV:BEIDou:NMEssage:DNAV:TIME:CONVersion:GLONass:AZERo.....	563
[:SOURCE<hw>]:BB:GNSS:SV:BEIDou:NMEssage:DNAV:TIME:CONVersion:GLONass:AZERo: UNSCaled.....	563
[:SOURCE<hw>]:BB:GNSS:SV:BEIDou:NMEssage:DNAV:TIME:CONVersion:GLONass:TOT.....	562
[:SOURCE<hw>]:BB:GNSS:SV:BEIDou:NMEssage:DNAV:TIME:CONVersion:GLONass:TOT:UNSCaled..	562
[:SOURCE<hw>]:BB:GNSS:SV:BEIDou:NMEssage:DNAV:TIME:CONVersion:GPS:AONE.....	560
[:SOURCE<hw>]:BB:GNSS:SV:BEIDou:NMEssage:DNAV:TIME:CONVersion:GPS:AONE:UNSCaled.....	560
[:SOURCE<hw>]:BB:GNSS:SV:BEIDou:NMEssage:DNAV:TIME:CONVersion:GPS:AZERo.....	559
[:SOURCE<hw>]:BB:GNSS:SV:BEIDou:NMEssage:DNAV:TIME:CONVersion:GPS:AZERo:UNSCaled.....	559
[:SOURCE<hw>]:BB:GNSS:SV:BEIDou:NMEssage:DNAV:TIME:CONVersion:GPS:TOT.....	559
[:SOURCE<hw>]:BB:GNSS:SV:BEIDou:NMEssage:DNAV:TIME:CONVersion:GPS:TOT:UNSCaled.....	559
[:SOURCE<hw>]:BB:GNSS:SV:BEIDou:NMEssage:DNAV:TIME:CONVersion:UTC:AONE.....	556
[:SOURCE<hw>]:BB:GNSS:SV:BEIDou:NMEssage:DNAV:TIME:CONVersion:UTC:AONE:UNSCaled.....	556
[:SOURCE<hw>]:BB:GNSS:SV:BEIDou:NMEssage:DNAV:TIME:CONVersion:UTC:AZERo.....	558
[:SOURCE<hw>]:BB:GNSS:SV:BEIDou:NMEssage:DNAV:TIME:CONVersion:UTC:AZERo:UNSCaled.....	558
[:SOURCE<hw>]:BB:GNSS:SV:BEIDou:NMEssage:DNAV:TIME:CONVersion:UTC:TOT.....	555
[:SOURCE<hw>]:BB:GNSS:SV:BEIDou:NMEssage:DNAV:TIME:CONVersion:UTC:TOT:UNSCaled.....	555
[:SOURCE<hw>]:BB:GNSS:SV:BEIDou:NMEssage:DNAV:TIME:CONVersion:UTC:WNOT.....	554
[:SOURCE<hw>]:BB:GNSS:SV:GALileo:NMEssage:FNAV:TIME:CONVersion:GPS:AONE.....	560
[:SOURCE<hw>]:BB:GNSS:SV:GALileo:NMEssage:FNAV:TIME:CONVersion:GPS:AONE:UNSCaled.....	560
[:SOURCE<hw>]:BB:GNSS:SV:GALileo:NMEssage:FNAV:TIME:CONVersion:GPS:AZERo.....	559
[:SOURCE<hw>]:BB:GNSS:SV:GALileo:NMEssage:FNAV:TIME:CONVersion:GPS:AZERo:UNSCaled.....	559
[:SOURCE<hw>]:BB:GNSS:SV:GALileo:NMEssage:FNAV:TIME:CONVersion:GPS:TOT.....	559
[:SOURCE<hw>]:BB:GNSS:SV:GALileo:NMEssage:FNAV:TIME:CONVersion:GPS:TOT:UNSCaled.....	559
[:SOURCE<hw>]:BB:GNSS:SV:GALileo:NMEssage:FNAV:TIME:CONVersion:GPS:WNOT.....	558
[:SOURCE<hw>]:BB:GNSS:SV:GALileo:NMEssage:FNAV:TIME:CONVersion:UTC:AONE.....	556
[:SOURCE<hw>]:BB:GNSS:SV:GALileo:NMEssage:FNAV:TIME:CONVersion:UTC:AONE:UNSCaled.....	556

[:SOURCE<hw>]:BB:GNSS:SV:GALileo:NMESSage:FNAV:TIME:CONVersion:UTC:AZERo.....	557
[:SOURCE<hw>]:BB:GNSS:SV:GALileo:NMESSage:FNAV:TIME:CONVersion:UTC:AZERo:UNSCaled.....	557
[:SOURCE<hw>]:BB:GNSS:SV:GALileo:NMESSage:FNAV:TIME:CONVersion:UTC:TOT.....	555
[:SOURCE<hw>]:BB:GNSS:SV:GALileo:NMESSage:FNAV:TIME:CONVersion:UTC:TOT:UNSCaled.....	554
[:SOURCE<hw>]:BB:GNSS:SV:GALileo:NMESSage:FNAV:TIME:CONVersion:UTC:WNOT.....	554
[:SOURCE<hw>]:BB:GNSS:SV:GALileo:NMESSage:INAV:TIME:CONVersion:GPS:AONE.....	560
[:SOURCE<hw>]:BB:GNSS:SV:GALileo:NMESSage:INAV:TIME:CONVersion:GPS:AONE:UNSCaled.....	560
[:SOURCE<hw>]:BB:GNSS:SV:GALileo:NMESSage:INAV:TIME:CONVersion:GPS:AZERo.....	559
[:SOURCE<hw>]:BB:GNSS:SV:GALileo:NMESSage:INAV:TIME:CONVersion:GPS:AZERo:UNSCaled.....	559
[:SOURCE<hw>]:BB:GNSS:SV:GALileo:NMESSage:INAV:TIME:CONVersion:GPS:TOT.....	559
[:SOURCE<hw>]:BB:GNSS:SV:GALileo:NMESSage:INAV:TIME:CONVersion:GPS:TOT:UNSCaled.....	559
[:SOURCE<hw>]:BB:GNSS:SV:GALileo:NMESSage:INAV:TIME:CONVersion:GPS:WNOT.....	558
[:SOURCE<hw>]:BB:GNSS:SV:GALileo:NMESSage:INAV:TIME:CONVersion:UTC:AONE.....	556
[:SOURCE<hw>]:BB:GNSS:SV:GALileo:NMESSage:INAV:TIME:CONVersion:UTC:AONE:UNSCaled.....	556
[:SOURCE<hw>]:BB:GNSS:SV:GALileo:NMESSage:INAV:TIME:CONVersion:UTC:AZERo.....	558
[:SOURCE<hw>]:BB:GNSS:SV:GALileo:NMESSage:INAV:TIME:CONVersion:UTC:AZERo:UNSCaled.....	557
[:SOURCE<hw>]:BB:GNSS:SV:GALileo:NMESSage:INAV:TIME:CONVersion:UTC:TOT.....	555
[:SOURCE<hw>]:BB:GNSS:SV:GALileo:NMESSage:INAV:TIME:CONVersion:UTC:TOT:UNSCaled.....	555
[:SOURCE<hw>]:BB:GNSS:SV:GALileo:NMESSage:INAV:TIME:CONVersion:UTC:WNOT.....	554
[:SOURCE<hw>]:BB:GNSS:SV:GLONass:NMESSage:NAV:TIME:CONVersion:GPS:AZERo.....	559
[:SOURCE<hw>]:BB:GNSS:SV:GLONass:NMESSage:NAV:TIME:CONVersion:GPS:AZERo:UNSCaled....	559
[:SOURCE<hw>]:BB:GNSS:SV:GLONass:NMESSage:NAV:TIME:CONVersion:UTC:AONE.....	556
[:SOURCE<hw>]:BB:GNSS:SV:GLONass:NMESSage:NAV:TIME:CONVersion:UTC:AONE:UNSCaled.....	556
[:SOURCE<hw>]:BB:GNSS:SV:GLONass:NMESSage:NAV:TIME:CONVersion:UTC:AZERo.....	558
[:SOURCE<hw>]:BB:GNSS:SV:GLONass:NMESSage:NAV:TIME:CONVersion:UTC:AZERo:UNSCaled....	558
[:SOURCE<hw>]:BB:GNSS:SV:GPS:NMESSage:CNAV:TIME:CONVersion:GALileo:AONE.....	562
[:SOURCE<hw>]:BB:GNSS:SV:GPS:NMESSage:CNAV:TIME:CONVersion:GALileo:AONE:UNSCaled.....	562
[:SOURCE<hw>]:BB:GNSS:SV:GPS:NMESSage:CNAV:TIME:CONVersion:GALileo:ATWO.....	562
[:SOURCE<hw>]:BB:GNSS:SV:GPS:NMESSage:CNAV:TIME:CONVersion:GALileo:ATWO:UNSCaled.....	562
[:SOURCE<hw>]:BB:GNSS:SV:GPS:NMESSage:CNAV:TIME:CONVersion:GALileo:AZERo.....	561
[:SOURCE<hw>]:BB:GNSS:SV:GPS:NMESSage:CNAV:TIME:CONVersion:GALileo:AZERo:UNSCaled....	561
[:SOURCE<hw>]:BB:GNSS:SV:GPS:NMESSage:CNAV:TIME:CONVersion:GALileo:TOT.....	561
[:SOURCE<hw>]:BB:GNSS:SV:GPS:NMESSage:CNAV:TIME:CONVersion:GALileo:TOT:UNSCaled.....	561
[:SOURCE<hw>]:BB:GNSS:SV:GPS:NMESSage:CNAV:TIME:CONVersion:GALileo:WNOT.....	560
[:SOURCE<hw>]:BB:GNSS:SV:GPS:NMESSage:CNAV:TIME:CONVersion:GLONass:AONE.....	563
[:SOURCE<hw>]:BB:GNSS:SV:GPS:NMESSage:CNAV:TIME:CONVersion:GLONass:AONE:UNSCaled...	563
[:SOURCE<hw>]:BB:GNSS:SV:GPS:NMESSage:CNAV:TIME:CONVersion:GLONass:ATWO.....	563
[:SOURCE<hw>]:BB:GNSS:SV:GPS:NMESSage:CNAV:TIME:CONVersion:GLONass:ATWO:UNSCaled...	563
[:SOURCE<hw>]:BB:GNSS:SV:GPS:NMESSage:CNAV:TIME:CONVersion:GLONass:AZERo.....	563
[:SOURCE<hw>]:BB:GNSS:SV:GPS:NMESSage:CNAV:TIME:CONVersion:GLONass:AZERo:UNSCaled..	563
[:SOURCE<hw>]:BB:GNSS:SV:GPS:NMESSage:CNAV:TIME:CONVersion:GLONass:TOT.....	562
[:SOURCE<hw>]:BB:GNSS:SV:GPS:NMESSage:CNAV:TIME:CONVersion:GLONass:TOT:UNSCaled.....	562
[:SOURCE<hw>]:BB:GNSS:SV:GPS:NMESSage:CNAV:TIME:CONVersion:GLONass:WNOT.....	562
[:SOURCE<hw>]:BB:GNSS:SV:GPS:NMESSage:CNAV:TIME:CONVersion:UTC:AONE.....	557
[:SOURCE<hw>]:BB:GNSS:SV:GPS:NMESSage:CNAV:TIME:CONVersion:UTC:AONE:UNSCaled.....	557
[:SOURCE<hw>]:BB:GNSS:SV:GPS:NMESSage:CNAV:TIME:CONVersion:UTC:ATWO.....	555
[:SOURCE<hw>]:BB:GNSS:SV:GPS:NMESSage:CNAV:TIME:CONVersion:UTC:ATWO:UNSCaled.....	555
[:SOURCE<hw>]:BB:GNSS:SV:GPS:NMESSage:CNAV:TIME:CONVersion:UTC:AZERo.....	558
[:SOURCE<hw>]:BB:GNSS:SV:GPS:NMESSage:CNAV:TIME:CONVersion:UTC:AZERo:UNSCaled.....	558
[:SOURCE<hw>]:BB:GNSS:SV:GPS:NMESSage:CNAV:TIME:CONVersion:UTC:TOT.....	555

[SOURce<hw>]:BB:GNSS:SV:GPS:NMESSage:CNAV:TIME:CONVersion:UTC:TOT:UNSCaled.....	555
[SOURce<hw>]:BB:GNSS:SV:GPS:NMESSage:CNAV:TIME:CONVersion:UTC:WNOT.....	554
[SOURce<hw>]:BB:GNSS:SV:GPS:NMESSage:LNAV:TIME:CONVersion:UTC:AONE.....	557
[SOURce<hw>]:BB:GNSS:SV:GPS:NMESSage:LNAV:TIME:CONVersion:UTC:AONE:UNSCaled.....	557
[SOURce<hw>]:BB:GNSS:SV:GPS:NMESSage:LNAV:TIME:CONVersion:UTC:AZERo.....	558
[SOURce<hw>]:BB:GNSS:SV:GPS:NMESSage:LNAV:TIME:CONVersion:UTC:AZERo:UNSCaled.....	558
[SOURce<hw>]:BB:GNSS:SV:GPS:NMESSage:LNAV:TIME:CONVersion:UTC:TOT.....	555
[SOURce<hw>]:BB:GNSS:SV:GPS:NMESSage:LNAV:TIME:CONVersion:UTC:TOT:UNSCaled.....	555
[SOURce<hw>]:BB:GNSS:SV:GPS:NMESSage:LNAV:TIME:CONVersion:UTC:WNOT.....	554
[SOURce<hw>]:BB:GNSS:SV:IMPor:BEIDou:EXECute.....	448
[SOURce<hw>]:BB:GNSS:SV:IMPor:BEIDou:FILE:CONStellation.....	446
[SOURce<hw>]:BB:GNSS:SV:IMPor:BEIDou:FILE:NMESSage.....	447
[SOURce<hw>]:BB:GNSS:SV:IMPor:BEIDou:UALL.....	447
[SOURce<hw>]:BB:GNSS:SV:IMPor:BEIDou:UDSource.....	447
[SOURce<hw>]:BB:GNSS:SV:IMPor:GALileo:EXECute.....	448
[SOURce<hw>]:BB:GNSS:SV:IMPor:GALileo:FILE:CONStellation.....	446
[SOURce<hw>]:BB:GNSS:SV:IMPor:GALileo:FILE:NMESSage.....	447
[SOURce<hw>]:BB:GNSS:SV:IMPor:GALileo:UALL.....	447
[SOURce<hw>]:BB:GNSS:SV:IMPor:GALileo:UDSource.....	447
[SOURce<hw>]:BB:GNSS:SV:IMPor:GLONass:EXECute.....	448
[SOURce<hw>]:BB:GNSS:SV:IMPor:GLONass:FILE:CONStellation.....	446
[SOURce<hw>]:BB:GNSS:SV:IMPor:GLONass:FILE:NMESSage.....	447
[SOURce<hw>]:BB:GNSS:SV:IMPor:GLONass:UALL.....	447
[SOURce<hw>]:BB:GNSS:SV:IMPor:GLONass:UDSource.....	447
[SOURce<hw>]:BB:GNSS:SV:IMPor:GPS:EXECute.....	448
[SOURce<hw>]:BB:GNSS:SV:IMPor:GPS:FILE:CONStellation.....	446
[SOURce<hw>]:BB:GNSS:SV:IMPor:GPS:FILE:NMESSage.....	447
[SOURce<hw>]:BB:GNSS:SV:IMPor:GPS:UALL.....	447
[SOURce<hw>]:BB:GNSS:SV:IMPor:GPS:UDSource.....	447
[SOURce<hw>]:BB:GNSS:SV:IMPor:NAVic:EXECute.....	447
[SOURce<hw>]:BB:GNSS:SV:IMPor:NAVic:FILE:CONStellation.....	446
[SOURce<hw>]:BB:GNSS:SV:IMPor:NAVic:FILE:NMESSage.....	447
[SOURce<hw>]:BB:GNSS:SV:IMPor:NAVic:UALL.....	447
[SOURce<hw>]:BB:GNSS:SV:IMPor:NAVic:UDSource.....	447
[SOURce<hw>]:BB:GNSS:SV:IMPor:QZSS:EXECute.....	447
[SOURce<hw>]:BB:GNSS:SV:IMPor:QZSS:FILE:CONStellation.....	446
[SOURce<hw>]:BB:GNSS:SV:IMPor:QZSS:FILE:NMESSage.....	447
[SOURce<hw>]:BB:GNSS:SV:IMPor:QZSS:UALL.....	447
[SOURce<hw>]:BB:GNSS:SV:IMPor:QZSS:UDSource.....	447
[SOURce<hw>]:BB:GNSS:SV:IMPor:SBAS:EGNOS:ADD:DIR.....	583
[SOURce<hw>]:BB:GNSS:SV:IMPor:SBAS:EGNOS:ADD:FILE.....	583
[SOURce<hw>]:BB:GNSS:SV:IMPor:SBAS:EGNOS:EXECute.....	584
[SOURce<hw>]:BB:GNSS:SV:IMPor:SBAS:EGNOS:LIST?.....	584
[SOURce<hw>]:BB:GNSS:SV:IMPor:SBAS:EGNOS:REMOve:ALL.....	584
[SOURce<hw>]:BB:GNSS:SV:IMPor:SBAS:EGNOS:REMOve:FILE<ch>.....	585
[SOURce<hw>]:BB:GNSS:SV:IMPor:SBAS:WAAS:ADD:DIR.....	583
[SOURce<hw>]:BB:GNSS:SV:IMPor:SBAS:WAAS:ADD:FILE.....	583
[SOURce<hw>]:BB:GNSS:SV:IMPor:SBAS:WAAS:EXECute.....	584
[SOURce<hw>]:BB:GNSS:SV:IMPor:SBAS:WAAS:LIST?.....	584
[SOURce<hw>]:BB:GNSS:SV:IMPor:SBAS:WAAS:REMOve:ALL.....	584

[:SOURCE<hw>]:BB:GNSS:SV:IMPort:SBAS:WAAS:REMOve:FILE<ch>.....	585
[:SOURCE<hw>]:BB:GNSS:SV:NAVic:NMEssage:NAV:TIME:CONVersion:GPS:AONE.....	560
[:SOURCE<hw>]:BB:GNSS:SV:NAVic:NMEssage:NAV:TIME:CONVersion:GPS:AONE:UNSCaled.....	560
[:SOURCE<hw>]:BB:GNSS:SV:NAVic:NMEssage:NAV:TIME:CONVersion:GPS:ATWO.....	560
[:SOURCE<hw>]:BB:GNSS:SV:NAVic:NMEssage:NAV:TIME:CONVersion:GPS:ATWO:UNSCaled.....	560
[:SOURCE<hw>]:BB:GNSS:SV:NAVic:NMEssage:NAV:TIME:CONVersion:GPS:AZERo.....	559
[:SOURCE<hw>]:BB:GNSS:SV:NAVic:NMEssage:NAV:TIME:CONVersion:GPS:AZERo:UNSCaled.....	559
[:SOURCE<hw>]:BB:GNSS:SV:NAVic:NMEssage:NAV:TIME:CONVersion:GPS:TOT.....	558
[:SOURCE<hw>]:BB:GNSS:SV:NAVic:NMEssage:NAV:TIME:CONVersion:GPS:TOT:UNSCaled.....	558
[:SOURCE<hw>]:BB:GNSS:SV:NAVic:NMEssage:NAV:TIME:CONVersion:GPS:WNOT.....	558
[:SOURCE<hw>]:BB:GNSS:SV:NAVic:NMEssage:NAV:TIME:CONVersion:UTC:AONE.....	556
[:SOURCE<hw>]:BB:GNSS:SV:NAVic:NMEssage:NAV:TIME:CONVersion:UTC:AONE:UNSCaled.....	556
[:SOURCE<hw>]:BB:GNSS:SV:NAVic:NMEssage:NAV:TIME:CONVersion:UTC:ATWO.....	555
[:SOURCE<hw>]:BB:GNSS:SV:NAVic:NMEssage:NAV:TIME:CONVersion:UTC:ATWO:UNSCaled.....	555
[:SOURCE<hw>]:BB:GNSS:SV:NAVic:NMEssage:NAV:TIME:CONVersion:UTC:AZERo.....	557
[:SOURCE<hw>]:BB:GNSS:SV:NAVic:NMEssage:NAV:TIME:CONVersion:UTC:AZERo:UNSCaled.....	557
[:SOURCE<hw>]:BB:GNSS:SV:NAVic:NMEssage:NAV:TIME:CONVersion:UTC:TOT.....	554
[:SOURCE<hw>]:BB:GNSS:SV:NAVic:NMEssage:NAV:TIME:CONVersion:UTC:TOT:UNSCaled.....	554
[:SOURCE<hw>]:BB:GNSS:SV:NAVic:NMEssage:NAV:TIME:CONVersion:UTC:WNOT.....	553
[:SOURCE<hw>]:BB:GNSS:SV:QZSS:NMEssage:CNAV:TIME:CONVersion:UTC:AONE.....	556
[:SOURCE<hw>]:BB:GNSS:SV:QZSS:NMEssage:CNAV:TIME:CONVersion:UTC:AONE:UNSCaled.....	556
[:SOURCE<hw>]:BB:GNSS:SV:QZSS:NMEssage:CNAV:TIME:CONVersion:UTC:ATWO.....	555
[:SOURCE<hw>]:BB:GNSS:SV:QZSS:NMEssage:CNAV:TIME:CONVersion:UTC:ATWO:UNSCaled.....	555
[:SOURCE<hw>]:BB:GNSS:SV:QZSS:NMEssage:CNAV:TIME:CONVersion:UTC:AZERo.....	557
[:SOURCE<hw>]:BB:GNSS:SV:QZSS:NMEssage:CNAV:TIME:CONVersion:UTC:AZERo:UNSCaled.....	557
[:SOURCE<hw>]:BB:GNSS:SV:QZSS:NMEssage:CNAV:TIME:CONVersion:UTC:TOT.....	554
[:SOURCE<hw>]:BB:GNSS:SV:QZSS:NMEssage:CNAV:TIME:CONVersion:UTC:TOT:UNSCaled.....	554
[:SOURCE<hw>]:BB:GNSS:SV:QZSS:NMEssage:CNAV:TIME:CONVersion:UTC:WNOT.....	553
[:SOURCE<hw>]:BB:GNSS:SV:QZSS:NMEssage:NAV:TIME:CONVersion:UTC:AONE.....	556
[:SOURCE<hw>]:BB:GNSS:SV:QZSS:NMEssage:NAV:TIME:CONVersion:UTC:AONE:UNSCaled.....	556
[:SOURCE<hw>]:BB:GNSS:SV:QZSS:NMEssage:NAV:TIME:CONVersion:UTC:AZERo.....	557
[:SOURCE<hw>]:BB:GNSS:SV:QZSS:NMEssage:NAV:TIME:CONVersion:UTC:AZERo:UNSCaled.....	557
[:SOURCE<hw>]:BB:GNSS:SV:QZSS:NMEssage:NAV:TIME:CONVersion:UTC:TOT.....	554
[:SOURCE<hw>]:BB:GNSS:SV:QZSS:NMEssage:NAV:TIME:CONVersion:UTC:TOT:UNSCaled.....	554
[:SOURCE<hw>]:BB:GNSS:SV:QZSS:NMEssage:NAV:TIME:CONVersion:UTC:WNOT.....	553
[:SOURCE<hw>]:BB:GNSS:SV:SBAS:EGNOS:NMEssage:NAV:TIME:CONVersion:UTC:AONE.....	556
[:SOURCE<hw>]:BB:GNSS:SV:SBAS:EGNOS:NMEssage:NAV:TIME:CONVersion:UTC:AONE: UNSCaled.....	556
[:SOURCE<hw>]:BB:GNSS:SV:SBAS:EGNOS:NMEssage:NAV:TIME:CONVersion:UTC:AZERo.....	557
[:SOURCE<hw>]:BB:GNSS:SV:SBAS:EGNOS:NMEssage:NAV:TIME:CONVersion:UTC:AZERo: UNSCaled.....	557
[:SOURCE<hw>]:BB:GNSS:SV:SBAS:EGNOS:NMEssage:NAV:TIME:CONVersion:UTC:TOT.....	554
[:SOURCE<hw>]:BB:GNSS:SV:SBAS:EGNOS:NMEssage:NAV:TIME:CONVersion:UTC:TOT:UNSCaled.....	554
[:SOURCE<hw>]:BB:GNSS:SV:SBAS:EGNOS:NMEssage:NAV:TIME:CONVersion:UTC:WNOT.....	553
[:SOURCE<hw>]:BB:GNSS:SV:SBAS:GAGAN:NMEssage:NAV:TIME:CONVersion:UTC:AONE.....	556
[:SOURCE<hw>]:BB:GNSS:SV:SBAS:GAGAN:NMEssage:NAV:TIME:CONVersion:UTC:AONE: UNSCaled.....	556
[:SOURCE<hw>]:BB:GNSS:SV:SBAS:GAGAN:NMEssage:NAV:TIME:CONVersion:UTC:AZERo.....	557
[:SOURCE<hw>]:BB:GNSS:SV:SBAS:GAGAN:NMEssage:NAV:TIME:CONVersion:UTC:AZERo: UNSCaled.....	557

[:SOURCE<hw>]:BB:GNSS:SV:SBAS:GAGAN:NMESSage:NAV:TIME:CONVersion:UTC:TOT.....	554
[:SOURCE<hw>]:BB:GNSS:SV:SBAS:GAGAN:NMESSage:NAV:TIME:CONVersion:UTC:TOT:UNSCaled..	554
[:SOURCE<hw>]:BB:GNSS:SV:SBAS:GAGAN:NMESSage:NAV:TIME:CONVersion:UTC:WNOT.....	553
[:SOURCE<hw>]:BB:GNSS:SV:SBAS:MSAS:NMESSage:NAV:TIME:CONVersion:UTC:AONE.....	556
[:SOURCE<hw>]:BB:GNSS:SV:SBAS:MSAS:NMESSage:NAV:TIME:CONVersion:UTC:AONE:UNSCaled.	556
[:SOURCE<hw>]:BB:GNSS:SV:SBAS:MSAS:NMESSage:NAV:TIME:CONVersion:UTC:AZERo.....	557
[:SOURCE<hw>]:BB:GNSS:SV:SBAS:MSAS:NMESSage:NAV:TIME:CONVersion:UTC:AZERo:UNSCaled	557
[:SOURCE<hw>]:BB:GNSS:SV:SBAS:MSAS:NMESSage:NAV:TIME:CONVersion:UTC:TOT.....	554
[:SOURCE<hw>]:BB:GNSS:SV:SBAS:MSAS:NMESSage:NAV:TIME:CONVersion:UTC:TOT:UNSCaled....	554
[:SOURCE<hw>]:BB:GNSS:SV:SBAS:MSAS:NMESSage:NAV:TIME:CONVersion:UTC:WNOT.....	553
[:SOURCE<hw>]:BB:GNSS:SV:SBAS:WAAS:NMESSage:NAV:TIME:CONVersion:UTC:AONE.....	556
[:SOURCE<hw>]:BB:GNSS:SV:SBAS:WAAS:NMESSage:NAV:TIME:CONVersion:UTC:AONE:UNSCaled.	556
[:SOURCE<hw>]:BB:GNSS:SV:SBAS:WAAS:NMESSage:NAV:TIME:CONVersion:UTC:AZERo.....	557
[:SOURCE<hw>]:BB:GNSS:SV:SBAS:WAAS:NMESSage:NAV:TIME:CONVersion:UTC:AZERo: UNSCaled.....	557
[:SOURCE<hw>]:BB:GNSS:SV:SBAS:WAAS:NMESSage:NAV:TIME:CONVersion:UTC:TOT.....	554
[:SOURCE<hw>]:BB:GNSS:SV:SBAS:WAAS:NMESSage:NAV:TIME:CONVersion:UTC:TOT:UNSCaled....	554
[:SOURCE<hw>]:BB:GNSS:SV:SBAS:WAAS:NMESSage:NAV:TIME:CONVersion:UTC:WNOT.....	553
[:SOURCE<hw>]:BB:GNSS:SV:SELection:BEIDou:ACTive?.....	443
[:SOURCE<hw>]:BB:GNSS:SV:SELection:BEIDou:AVAIlable?.....	443
[:SOURCE<hw>]:BB:GNSS:SV:SELection:BEIDou:MAX.....	442
[:SOURCE<hw>]:BB:GNSS:SV:SELection:BEIDou:MIN.....	442
[:SOURCE<hw>]:BB:GNSS:SV:SELection:CHANnels:MAX.....	442
[:SOURCE<hw>]:BB:GNSS:SV:SELection:EOBScuration:ANGLE.....	442
[:SOURCE<hw>]:BB:GNSS:SV:SELection:EOBScuration:REFERENCE.....	441
[:SOURCE<hw>]:BB:GNSS:SV:SELection:GALileo:ACTive?.....	443
[:SOURCE<hw>]:BB:GNSS:SV:SELection:GALileo:AVAIlable?.....	443
[:SOURCE<hw>]:BB:GNSS:SV:SELection:GALileo:MAX.....	443
[:SOURCE<hw>]:BB:GNSS:SV:SELection:GALileo:MIN.....	443
[:SOURCE<hw>]:BB:GNSS:SV:SELection:GLONass:ACTive?.....	443
[:SOURCE<hw>]:BB:GNSS:SV:SELection:GLONass:AVAIlable?.....	443
[:SOURCE<hw>]:BB:GNSS:SV:SELection:GLONass:MAX.....	442
[:SOURCE<hw>]:BB:GNSS:SV:SELection:GLONass:MIN.....	442
[:SOURCE<hw>]:BB:GNSS:SV:SELection:GPS:ACTive?.....	443
[:SOURCE<hw>]:BB:GNSS:SV:SELection:GPS:AVAIlable?.....	443
[:SOURCE<hw>]:BB:GNSS:SV:SELection:GPS:MAX.....	443
[:SOURCE<hw>]:BB:GNSS:SV:SELection:GPS:MIN.....	443
[:SOURCE<hw>]:BB:GNSS:SV:SELection:MODE.....	441
[:SOURCE<hw>]:BB:GNSS:SV:SELection:NAVic:ACTive?.....	443
[:SOURCE<hw>]:BB:GNSS:SV:SELection:NAVic:AVAIlable?.....	443
[:SOURCE<hw>]:BB:GNSS:SV:SELection:NAVic:MAX.....	442
[:SOURCE<hw>]:BB:GNSS:SV:SELection:NAVic:MIN.....	442
[:SOURCE<hw>]:BB:GNSS:SV:SELection:QZSS:ACTive?.....	443
[:SOURCE<hw>]:BB:GNSS:SV:SELection:QZSS:AVAIlable?.....	443
[:SOURCE<hw>]:BB:GNSS:SV:SELection:QZSS:MAX.....	442
[:SOURCE<hw>]:BB:GNSS:SV:SELection:QZSS:MIN.....	442
[:SOURCE<hw>]:BB:GNSS:SV:SELection:REFERENCE:VEHicle.....	639
[:SOURCE<hw>]:BB:GNSS:SV:SELection:SBAS:ACTive?.....	443
[:SOURCE<hw>]:BB:GNSS:SV:SELection:SBAS:AVAIlable?.....	443
[:SOURCE<hw>]:BB:GNSS:SV:SELection:SBAS:MAX.....	442

[SOURce<hw>]:BB:GNSS:SV:SElection:SBAS:MIN.....	442
[SOURce<hw>]:BB:GNSS:SVID:BEIDou:LIST:ALL?.....	444
[SOURce<hw>]:BB:GNSS:SVID:BEIDou:LIST[:VALid]?.....	444
[SOURce<hw>]:BB:GNSS:SVID:GALileo:LIST:ALL?.....	444
[SOURce<hw>]:BB:GNSS:SVID:GALileo:LIST[:VALid]?.....	444
[SOURce<hw>]:BB:GNSS:SVID:GLONass:LIST:ALL?.....	444
[SOURce<hw>]:BB:GNSS:SVID:GLONass:LIST[:VALid]?.....	444
[SOURce<hw>]:BB:GNSS:SVID:GPS:LIST:ALL?.....	444
[SOURce<hw>]:BB:GNSS:SVID:GPS:LIST[:VALid]?.....	444
[SOURce<hw>]:BB:GNSS:SVID:NAVic:LIST:ALL?.....	444
[SOURce<hw>]:BB:GNSS:SVID:NAVic:LIST[:VALid]?.....	444
[SOURce<hw>]:BB:GNSS:SVID:QZSS:LIST:ALL?.....	444
[SOURce<hw>]:BB:GNSS:SVID:QZSS:LIST[:VALid]?.....	444
[SOURce<hw>]:BB:GNSS:SVID:SBAS:LIST:ALL?.....	444
[SOURce<hw>]:BB:GNSS:SVID:SBAS:LIST[:VALid]?.....	444
[SOURce<hw>]:BB:GNSS:SVID<ch>:BEIDou:HEALThy.....	445
[SOURce<hw>]:BB:GNSS:SVID<ch>:BEIDou:MCONtrol:COPI:EXECute.....	478
[SOURce<hw>]:BB:GNSS:SVID<ch>:BEIDou:MCONtrol:COPI:SVID.....	477
[SOURce<hw>]:BB:GNSS:SVID<ch>:BEIDou:MPATH[:V<us>:A<gr>]:ECHO<s2us0>:AAZimuth.....	426
[SOURce<hw>]:BB:GNSS:SVID<ch>:BEIDou:MPATH[:V<us>:A<gr>]:ECHO<s2us0>:AELEVation.....	427
[SOURce<hw>]:BB:GNSS:SVID<ch>:BEIDou:MPATH[:V<us>:A<gr>]:ECHO<s2us0>:CPDRift.....	423
[SOURce<hw>]:BB:GNSS:SVID<ch>:BEIDou:MPATH[:V<us>:A<gr>]:ECHO<s2us0>:CPHase.....	425
[SOURce<hw>]:BB:GNSS:SVID<ch>:BEIDou:MPATH[:V<us>:A<gr>]:ECHO<s2us0>:DSHift.....	425
[SOURce<hw>]:BB:GNSS:SVID<ch>:BEIDou:MPATH[:V<us>:A<gr>]:ECHO<s2us0>:ICPHase.....	422
[SOURce<hw>]:BB:GNSS:SVID<ch>:BEIDou:MPATH[:V<us>:A<gr>]:ECHO<s2us0>:POWER.....	424
[SOURce<hw>]:BB:GNSS:SVID<ch>:BEIDou:MPATH[:V<us>:A<gr>]:ECHO:s:COUNT.....	422
[SOURce<hw>]:BB:GNSS:SVID<ch>:BEIDou:MPATH[:V<us>:A<gr>]:LOS:AAZimuth?.....	426
[SOURce<hw>]:BB:GNSS:SVID<ch>:BEIDou:MPATH[:V<us>:A<gr>]:LOS:AELEVation?.....	427
[SOURce<hw>]:BB:GNSS:SVID<ch>:BEIDou:MPATH[:V<us>:A<gr>]:LOS:CPDRift?.....	423
[SOURce<hw>]:BB:GNSS:SVID<ch>:BEIDou:MPATH[:V<us>:A<gr>]:LOS:CPHase?.....	425
[SOURce<hw>]:BB:GNSS:SVID<ch>:BEIDou:MPATH[:V<us>:A<gr>]:LOS:DSHift?.....	425
[SOURce<hw>]:BB:GNSS:SVID<ch>:BEIDou:MPATH[:V<us>:A<gr>]:LOS:ENABLE.....	421
[SOURce<hw>]:BB:GNSS:SVID<ch>:BEIDou:MPATH[:V<us>:A<gr>]:LOS:ICPHase?.....	422
[SOURce<hw>]:BB:GNSS:SVID<ch>:BEIDou:MPATH[:V<us>:A<gr>]:LOS:POWER?.....	424
[SOURce<hw>]:BB:GNSS:SVID<ch>:BEIDou:NMESsage:CNAV:CCORrection:AF<s2us0>.....	541
[SOURce<hw>]:BB:GNSS:SVID<ch>:BEIDou:NMESsage:CNAV:CCORrection:AF<s2us0>:UNSCaled.....	541
[SOURce<hw>]:BB:GNSS:SVID<ch>:BEIDou:NMESsage:CNAV:CCORrection:TGD.....	542
[SOURce<hw>]:BB:GNSS:SVID<ch>:BEIDou:NMESsage:CNAV:CCORrection:TGD:UNSCaled.....	542
[SOURce<hw>]:BB:GNSS:SVID<ch>:BEIDou:NMESsage:CNAV:CCORrection:TOC.....	540
[SOURce<hw>]:BB:GNSS:SVID<ch>:BEIDou:NMESsage:CNAV:CCORrection:TOC:UNSCaled.....	540
[SOURce<hw>]:BB:GNSS:SVID<ch>:BEIDou:NMESsage:CNAV:EPHemeris:ADELta.....	531
[SOURce<hw>]:BB:GNSS:SVID<ch>:BEIDou:NMESsage:CNAV:EPHemeris:ADELta:UNSCaled.....	531
[SOURce<hw>]:BB:GNSS:SVID<ch>:BEIDou:NMESsage:CNAV:EPHemeris:ADOT.....	531
[SOURce<hw>]:BB:GNSS:SVID<ch>:BEIDou:NMESsage:CNAV:EPHemeris:ADOT:UNSCaled.....	531
[SOURce<hw>]:BB:GNSS:SVID<ch>:BEIDou:NMESsage:CNAV:EPHemeris:ALERt.....	545
[SOURce<hw>]:BB:GNSS:SVID<ch>:BEIDou:NMESsage:CNAV:EPHemeris:CIC.....	538
[SOURce<hw>]:BB:GNSS:SVID<ch>:BEIDou:NMESsage:CNAV:EPHemeris:CIC:UNSCaled.....	538
[SOURce<hw>]:BB:GNSS:SVID<ch>:BEIDou:NMESsage:CNAV:EPHemeris:CIS.....	539
[SOURce<hw>]:BB:GNSS:SVID<ch>:BEIDou:NMESsage:CNAV:EPHemeris:CIS:UNSCaled.....	539
[SOURce<hw>]:BB:GNSS:SVID<ch>:BEIDou:NMESsage:CNAV:EPHemeris:CRC.....	536

[:SOURCE<hw>]:BB:GNSS:SVID<ch>:BEIDou:NMESsage:CNAV:EPHemeris:CRC:UNSCaled.....	536
[:SOURCE<hw>]:BB:GNSS:SVID<ch>:BEIDou:NMESsage:CNAV:EPHemeris:CRS.....	537
[:SOURCE<hw>]:BB:GNSS:SVID<ch>:BEIDou:NMESsage:CNAV:EPHemeris:CRS:UNSCaled.....	537
[:SOURCE<hw>]:BB:GNSS:SVID<ch>:BEIDou:NMESsage:CNAV:EPHemeris:CUC.....	535
[:SOURCE<hw>]:BB:GNSS:SVID<ch>:BEIDou:NMESsage:CNAV:EPHemeris:CUC:UNSCaled.....	535
[:SOURCE<hw>]:BB:GNSS:SVID<ch>:BEIDou:NMESsage:CNAV:EPHemeris:CUS.....	535
[:SOURCE<hw>]:BB:GNSS:SVID<ch>:BEIDou:NMESsage:CNAV:EPHemeris:CUS:UNSCaled.....	535
[:SOURCE<hw>]:BB:GNSS:SVID<ch>:BEIDou:NMESsage:CNAV:EPHemeris:DNDot.....	530
[:SOURCE<hw>]:BB:GNSS:SVID<ch>:BEIDou:NMESsage:CNAV:EPHemeris:DNDot:UNSCaled.....	530
[:SOURCE<hw>]:BB:GNSS:SVID<ch>:BEIDou:NMESsage:CNAV:EPHemeris:ECCentricity.....	523
[:SOURCE<hw>]:BB:GNSS:SVID<ch>:BEIDou:NMESsage:CNAV:EPHemeris:ECCentricity:UNSCaled.....	523
[:SOURCE<hw>]:BB:GNSS:SVID<ch>:BEIDou:NMESsage:CNAV:EPHemeris:IDOT.....	528
[:SOURCE<hw>]:BB:GNSS:SVID<ch>:BEIDou:NMESsage:CNAV:EPHemeris:IDOT:UNSCaled.....	528
[:SOURCE<hw>]:BB:GNSS:SVID<ch>:BEIDou:NMESsage:CNAV:EPHemeris:IZERo.....	524
[:SOURCE<hw>]:BB:GNSS:SVID<ch>:BEIDou:NMESsage:CNAV:EPHemeris:IZERo:UNSCaled.....	524
[:SOURCE<hw>]:BB:GNSS:SVID<ch>:BEIDou:NMESsage:CNAV:EPHemeris:MZERo.....	527
[:SOURCE<hw>]:BB:GNSS:SVID<ch>:BEIDou:NMESsage:CNAV:EPHemeris:MZERo:UNSCaled.....	527
[:SOURCE<hw>]:BB:GNSS:SVID<ch>:BEIDou:NMESsage:CNAV:EPHemeris:NDELta.....	530
[:SOURCE<hw>]:BB:GNSS:SVID<ch>:BEIDou:NMESsage:CNAV:EPHemeris:NDELta:UNSCaled.....	530
[:SOURCE<hw>]:BB:GNSS:SVID<ch>:BEIDou:NMESsage:CNAV:EPHemeris:ODOT.....	529
[:SOURCE<hw>]:BB:GNSS:SVID<ch>:BEIDou:NMESsage:CNAV:EPHemeris:ODOT:UNSCaled.....	529
[:SOURCE<hw>]:BB:GNSS:SVID<ch>:BEIDou:NMESsage:CNAV:EPHemeris:OMEGa.....	526
[:SOURCE<hw>]:BB:GNSS:SVID<ch>:BEIDou:NMESsage:CNAV:EPHemeris:OMEGa:UNSCaled.....	526
[:SOURCE<hw>]:BB:GNSS:SVID<ch>:BEIDou:NMESsage:CNAV:EPHemeris:OZERo.....	525
[:SOURCE<hw>]:BB:GNSS:SVID<ch>:BEIDou:NMESsage:CNAV:EPHemeris:OZERo:UNSCaled.....	525
[:SOURCE<hw>]:BB:GNSS:SVID<ch>:BEIDou:NMESsage:CNAV:EPHemeris:SQRA.....	523
[:SOURCE<hw>]:BB:GNSS:SVID<ch>:BEIDou:NMESsage:CNAV:EPHemeris:SQRA:UNSCaled.....	522
[:SOURCE<hw>]:BB:GNSS:SVID<ch>:BEIDou:NMESsage:CNAV:EPHemeris:TOE.....	522
[:SOURCE<hw>]:BB:GNSS:SVID<ch>:BEIDou:NMESsage:CNAV:EPHemeris:TOE:UNSCaled.....	522
[:SOURCE<hw>]:BB:GNSS:SVID<ch>:BEIDou:NMESsage:DNAV:CCORrection:AF<s2us0>.....	541
[:SOURCE<hw>]:BB:GNSS:SVID<ch>:BEIDou:NMESsage:DNAV:CCORrection:AF<s2us0>:UNSCaled.....	541
[:SOURCE<hw>]:BB:GNSS:SVID<ch>:BEIDou:NMESsage:DNAV:CCORrection:TGD<s2us>.....	542
[:SOURCE<hw>]:BB:GNSS:SVID<ch>:BEIDou:NMESsage:DNAV:CCORrection:TGD<s2us>:UNSCaled.....	542
[:SOURCE<hw>]:BB:GNSS:SVID<ch>:BEIDou:NMESsage:DNAV:CCORrection:TOC.....	540
[:SOURCE<hw>]:BB:GNSS:SVID<ch>:BEIDou:NMESsage:DNAV:CCORrection:TOC:UNSCaled.....	540
[:SOURCE<hw>]:BB:GNSS:SVID<ch>:BEIDou:NMESsage:DNAV:EPHemeris:CIC.....	538
[:SOURCE<hw>]:BB:GNSS:SVID<ch>:BEIDou:NMESsage:DNAV:EPHemeris:CIC:UNSCaled.....	538
[:SOURCE<hw>]:BB:GNSS:SVID<ch>:BEIDou:NMESsage:DNAV:EPHemeris:CIS.....	539
[:SOURCE<hw>]:BB:GNSS:SVID<ch>:BEIDou:NMESsage:DNAV:EPHemeris:CIS:UNSCaled.....	539
[:SOURCE<hw>]:BB:GNSS:SVID<ch>:BEIDou:NMESsage:DNAV:EPHemeris:CRS.....	536
[:SOURCE<hw>]:BB:GNSS:SVID<ch>:BEIDou:NMESsage:DNAV:EPHemeris:CRS:UNSCaled.....	536
[:SOURCE<hw>]:BB:GNSS:SVID<ch>:BEIDou:NMESsage:DNAV:EPHemeris:CRS.....	537
[:SOURCE<hw>]:BB:GNSS:SVID<ch>:BEIDou:NMESsage:DNAV:EPHemeris:CRS:UNSCaled.....	537
[:SOURCE<hw>]:BB:GNSS:SVID<ch>:BEIDou:NMESsage:DNAV:EPHemeris:CUC.....	535
[:SOURCE<hw>]:BB:GNSS:SVID<ch>:BEIDou:NMESsage:DNAV:EPHemeris:CUC:UNSCaled.....	535
[:SOURCE<hw>]:BB:GNSS:SVID<ch>:BEIDou:NMESsage:DNAV:EPHemeris:CUS.....	536
[:SOURCE<hw>]:BB:GNSS:SVID<ch>:BEIDou:NMESsage:DNAV:EPHemeris:CUS:UNSCaled.....	536
[:SOURCE<hw>]:BB:GNSS:SVID<ch>:BEIDou:NMESsage:DNAV:EPHemeris:ECCentricity.....	523
[:SOURCE<hw>]:BB:GNSS:SVID<ch>:BEIDou:NMESsage:DNAV:EPHemeris:ECCentricity:UNSCaled.....	523
[:SOURCE<hw>]:BB:GNSS:SVID<ch>:BEIDou:NMESsage:DNAV:EPHemeris:HEALth.....	547

[:SOURce<hw>]:BB:GNSS:SVID<ch>:BEIDou:NMESsage:DNAV:EPHemeris:IDOT.....	528
[:SOURce<hw>]:BB:GNSS:SVID<ch>:BEIDou:NMESsage:DNAV:EPHemeris:IDOT:UNSCaled.....	528
[:SOURce<hw>]:BB:GNSS:SVID<ch>:BEIDou:NMESsage:DNAV:EPHemeris:IODC.....	540
[:SOURce<hw>]:BB:GNSS:SVID<ch>:BEIDou:NMESsage:DNAV:EPHemeris:IODE.....	521
[:SOURce<hw>]:BB:GNSS:SVID<ch>:BEIDou:NMESsage:DNAV:EPHemeris:IZERo.....	524
[:SOURce<hw>]:BB:GNSS:SVID<ch>:BEIDou:NMESsage:DNAV:EPHemeris:IZERo:UNSCaled.....	524
[:SOURce<hw>]:BB:GNSS:SVID<ch>:BEIDou:NMESsage:DNAV:EPHemeris:MZERo.....	527
[:SOURce<hw>]:BB:GNSS:SVID<ch>:BEIDou:NMESsage:DNAV:EPHemeris:MZERo:UNSCaled.....	527
[:SOURce<hw>]:BB:GNSS:SVID<ch>:BEIDou:NMESsage:DNAV:EPHemeris:NDELta.....	530
[:SOURce<hw>]:BB:GNSS:SVID<ch>:BEIDou:NMESsage:DNAV:EPHemeris:NDELta:UNSCaled.....	530
[:SOURce<hw>]:BB:GNSS:SVID<ch>:BEIDou:NMESsage:DNAV:EPHemeris:ODOT.....	529
[:SOURce<hw>]:BB:GNSS:SVID<ch>:BEIDou:NMESsage:DNAV:EPHemeris:ODOT:UNSCaled.....	529
[:SOURce<hw>]:BB:GNSS:SVID<ch>:BEIDou:NMESsage:DNAV:EPHemeris:OMEGa.....	526
[:SOURce<hw>]:BB:GNSS:SVID<ch>:BEIDou:NMESsage:DNAV:EPHemeris:OMEGa:UNSCaled.....	526
[:SOURce<hw>]:BB:GNSS:SVID<ch>:BEIDou:NMESsage:DNAV:EPHemeris:OZERo.....	525
[:SOURce<hw>]:BB:GNSS:SVID<ch>:BEIDou:NMESsage:DNAV:EPHemeris:OZERo:UNSCaled.....	525
[:SOURce<hw>]:BB:GNSS:SVID<ch>:BEIDou:NMESsage:DNAV:EPHemeris:SQRA.....	523
[:SOURce<hw>]:BB:GNSS:SVID<ch>:BEIDou:NMESsage:DNAV:EPHemeris:SQRA:UNSCaled.....	523
[:SOURce<hw>]:BB:GNSS:SVID<ch>:BEIDou:NMESsage:DNAV:EPHemeris:TOE.....	522
[:SOURce<hw>]:BB:GNSS:SVID<ch>:BEIDou:NMESsage:DNAV:EPHemeris:TOE:UNSCaled.....	522
[:SOURce<hw>]:BB:GNSS:SVID<ch>:BEIDou:NMESsage:DNAV:EPHemeris:URA.....	548
[:SOURce<hw>]:BB:GNSS:SVID<ch>:BEIDou:POWer:COPIY:EXECute.....	463
[:SOURce<hw>]:BB:GNSS:SVID<ch>:BEIDou:POWer:COPIY:SVID.....	462
[:SOURce<hw>]:BB:GNSS:SVID<ch>:BEIDou:POWer:OFFSet.....	460
[:SOURce<hw>]:BB:GNSS:SVID<ch>:BEIDou:POWer:PLOSSs.....	460
[:SOURce<hw>]:BB:GNSS:SVID<ch>:BEIDou:PRERrors:COPIY:EXECute.....	495
[:SOURce<hw>]:BB:GNSS:SVID<ch>:BEIDou:PRERrors:COPIY:SVID.....	494
[:SOURce<hw>]:BB:GNSS:SVID<ch>:BEIDou:PRERrors:FILE.....	494
[:SOURce<hw>]:BB:GNSS:SVID<ch>:BEIDou:PRERrors:MODE.....	493
[:SOURce<hw>]:BB:GNSS:SVID<ch>:BEIDou:PRERrors:PROFile:APPend.....	497
[:SOURce<hw>]:BB:GNSS:SVID<ch>:BEIDou:PRERrors:PROFile:COUnT?.....	497
[:SOURce<hw>]:BB:GNSS:SVID<ch>:BEIDou:PRERrors:PROFile:OFFSet.....	496
[:SOURce<hw>]:BB:GNSS:SVID<ch>:BEIDou:PRERrors:PROFile<gr>:DELete.....	499
[:SOURce<hw>]:BB:GNSS:SVID<ch>:BEIDou:PRERrors:PROFile<gr>:INSert.....	499
[:SOURce<hw>]:BB:GNSS:SVID<ch>:BEIDou:PRERrors:PROFile<gr>:REFerence.....	497
[:SOURce<hw>]:BB:GNSS:SVID<ch>:BEIDou:PRERrors:PROFile<gr>:VALue.....	498
[:SOURce<hw>]:BB:GNSS:SVID<ch>:BEIDou:PRERrors:VALue.....	496
[:SOURce<hw>]:BB:GNSS:SVID<ch>:BEIDou:PRESEnt.....	459
[:SOURce<hw>]:BB:GNSS:SVID<ch>:BEIDou:SDYNamics:ACCel:MAX.....	595
[:SOURce<hw>]:BB:GNSS:SVID<ch>:BEIDou:SDYNamics:CAPeriod.....	594
[:SOURce<hw>]:BB:GNSS:SVID<ch>:BEIDou:SDYNamics:CONFig.....	593
[:SOURce<hw>]:BB:GNSS:SVID<ch>:BEIDou:SDYNamics:CPHase.....	591
[:SOURce<hw>]:BB:GNSS:SVID<ch>:BEIDou:SDYNamics:CVPeriod.....	594
[:SOURce<hw>]:BB:GNSS:SVID<ch>:BEIDou:SDYNamics:IVELocity.....	593
[:SOURce<hw>]:BB:GNSS:SVID<ch>:BEIDou:SDYNamics:JERK:MAX.....	595
[:SOURce<hw>]:BB:GNSS:SVID<ch>:BEIDou:SDYNamics:PRANge.....	591
[:SOURce<hw>]:BB:GNSS:SVID<ch>:BEIDou:SDYNamics:PROFile.....	590
[:SOURce<hw>]:BB:GNSS:SVID<ch>:BEIDou:SDYNamics:RPERiod?.....	596
[:SOURce<hw>]:BB:GNSS:SVID<ch>:BEIDou:SDYNamics:TOFFset.....	592
[:SOURce<hw>]:BB:GNSS:SVID<ch>:BEIDou:SDYNamics:VELocity.....	592

[:SOURce<hw>]:BB:GNSS:SVID<ch>:BEIDou:SIGNal:L5Band:B2I:DATA:NMEsSage:DSElect.....	473
[:SOURce<hw>]:BB:GNSS:SVID<ch>:BEIDou:SIGNal:L5Band:B2I:DATA:NMEsSage:PATtern.....	475
[:SOURce<hw>]:BB:GNSS:SVID<ch>:BEIDou:SIGNal:L5Band:B2I:DATA:NMEsSage:TYPE.....	471
[:SOURce<hw>]:BB:GNSS:SVID<ch>:BEIDou:SIGNal:L5Band:B2I:DATA:NMEsSage[:STATe].....	589
[:SOURce<hw>]:BB:GNSS:SVID<ch>:BEIDou:SIGNal:L5Band:B2I:DATA:PCODE[:STATe].....	465
[:SOURce<hw>]:BB:GNSS:SVID<ch>:BEIDou:SIGNal:L5Band:B2I:DATA:SCODE[:STATe].....	467
[:SOURce<hw>]:BB:GNSS:SVID<ch>:BEIDou:SIGNal:L5Band:B2I:POWER:OFFset.....	461
[:SOURce<hw>]:BB:GNSS:SVID<ch>:BEIDou:SIGNal:L5Band:B2I[:STATe].....	464
[:SOURce<hw>]:BB:GNSS:SVID<ch>:BEIDou:SIMulated:CLOCK:AF<s2us0>.....	490
[:SOURce<hw>]:BB:GNSS:SVID<ch>:BEIDou:SIMulated:CLOCK:TGD<s2us>.....	491
[:SOURce<hw>]:BB:GNSS:SVID<ch>:BEIDou:SIMulated:CLOCK:TOC.....	490
[:SOURce<hw>]:BB:GNSS:SVID<ch>:BEIDou:SIMulated:CLOCK:WNOc.....	490
[:SOURce<hw>]:BB:GNSS:SVID<ch>:BEIDou:SIMulated:ORBit:CIC.....	489
[:SOURce<hw>]:BB:GNSS:SVID<ch>:BEIDou:SIMulated:ORBit:CIS.....	490
[:SOURce<hw>]:BB:GNSS:SVID<ch>:BEIDou:SIMulated:ORBit:CRC.....	489
[:SOURce<hw>]:BB:GNSS:SVID<ch>:BEIDou:SIMulated:ORBit:CRS.....	489
[:SOURce<hw>]:BB:GNSS:SVID<ch>:BEIDou:SIMulated:ORBit:CUC.....	488
[:SOURce<hw>]:BB:GNSS:SVID<ch>:BEIDou:SIMulated:ORBit:CUS.....	488
[:SOURce<hw>]:BB:GNSS:SVID<ch>:BEIDou:SIMulated:ORBit:ECCentricity.....	486
[:SOURce<hw>]:BB:GNSS:SVID<ch>:BEIDou:SIMulated:ORBit:IDOT.....	487
[:SOURce<hw>]:BB:GNSS:SVID<ch>:BEIDou:SIMulated:ORBit:IZERo.....	486
[:SOURce<hw>]:BB:GNSS:SVID<ch>:BEIDou:SIMulated:ORBit:MZERo.....	487
[:SOURce<hw>]:BB:GNSS:SVID<ch>:BEIDou:SIMulated:ORBit:NDELta.....	488
[:SOURce<hw>]:BB:GNSS:SVID<ch>:BEIDou:SIMulated:ORBit:ODOT.....	488
[:SOURce<hw>]:BB:GNSS:SVID<ch>:BEIDou:SIMulated:ORBit:OMEGa.....	487
[:SOURce<hw>]:BB:GNSS:SVID<ch>:BEIDou:SIMulated:ORBit:OZERo.....	487
[:SOURce<hw>]:BB:GNSS:SVID<ch>:BEIDou:SIMulated:ORBit:SQRA.....	486
[:SOURce<hw>]:BB:GNSS:SVID<ch>:BEIDou:SIMulated:ORBit:TOE.....	484
[:SOURce<hw>]:BB:GNSS:SVID<ch>:BEIDou:SIMulated:ORBit:WNOE.....	484
[:SOURce<hw>]:BB:GNSS:SVID<ch>:BEIDou:STATe.....	458
[:SOURce<hw>]:BB:GNSS:SVID<ch>:BEIDou:VISibility:STATe?.....	446
[:SOURce<hw>]:BB:GNSS:SVID<ch>:GALileo:HEALTHy.....	445
[:SOURce<hw>]:BB:GNSS:SVID<ch>:GALileo:MCONtrol:COpy:EXECute.....	478
[:SOURce<hw>]:BB:GNSS:SVID<ch>:GALileo:MCONtrol:COpy:SVID.....	477
[:SOURce<hw>]:BB:GNSS:SVID<ch>:GALileo:MPATH[:V<us>:A<gr>]:ECHO<s2us0>:AAZimuth.....	426
[:SOURce<hw>]:BB:GNSS:SVID<ch>:GALileo:MPATH[:V<us>:A<gr>]:ECHO<s2us0>:AELEVation.....	427
[:SOURce<hw>]:BB:GNSS:SVID<ch>:GALileo:MPATH[:V<us>:A<gr>]:ECHO<s2us0>:CPDRift.....	423
[:SOURce<hw>]:BB:GNSS:SVID<ch>:GALileo:MPATH[:V<us>:A<gr>]:ECHO<s2us0>:CPHase.....	425
[:SOURce<hw>]:BB:GNSS:SVID<ch>:GALileo:MPATH[:V<us>:A<gr>]:ECHO<s2us0>:DSHift.....	425
[:SOURce<hw>]:BB:GNSS:SVID<ch>:GALileo:MPATH[:V<us>:A<gr>]:ECHO<s2us0>:ICPHase.....	422
[:SOURce<hw>]:BB:GNSS:SVID<ch>:GALileo:MPATH[:V<us>:A<gr>]:ECHO<s2us0>:POWER.....	424
[:SOURce<hw>]:BB:GNSS:SVID<ch>:GALileo:MPATH[:V<us>:A<gr>]:ECHos:COUNT.....	422
[:SOURce<hw>]:BB:GNSS:SVID<ch>:GALileo:MPATH[:V<us>:A<gr>]:LOS:AAZimuth?.....	426
[:SOURce<hw>]:BB:GNSS:SVID<ch>:GALileo:MPATH[:V<us>:A<gr>]:LOS:AELEVation?.....	427
[:SOURce<hw>]:BB:GNSS:SVID<ch>:GALileo:MPATH[:V<us>:A<gr>]:LOS:CPDRift?.....	423
[:SOURce<hw>]:BB:GNSS:SVID<ch>:GALileo:MPATH[:V<us>:A<gr>]:LOS:CPHase?.....	425
[:SOURce<hw>]:BB:GNSS:SVID<ch>:GALileo:MPATH[:V<us>:A<gr>]:LOS:DSHift?.....	425
[:SOURce<hw>]:BB:GNSS:SVID<ch>:GALileo:MPATH[:V<us>:A<gr>]:LOS:ENABle.....	421
[:SOURce<hw>]:BB:GNSS:SVID<ch>:GALileo:MPATH[:V<us>:A<gr>]:LOS:ICPHase?.....	422
[:SOURce<hw>]:BB:GNSS:SVID<ch>:GALileo:MPATH[:V<us>:A<gr>]:LOS:POWER?.....	424

[:SOURCE<hw>]:BB:GNSS:SVID<ch>:GALileo:NMESsage:FNAV:CCORrection:AF<s2us0>.....	541
[:SOURCE<hw>]:BB:GNSS:SVID<ch>:GALileo:NMESsage:FNAV:CCORrection:AF<s2us0>:UNSCaled....	541
[:SOURCE<hw>]:BB:GNSS:SVID<ch>:GALileo:NMESsage:FNAV:CCORrection:BGDA.....	543
[:SOURCE<hw>]:BB:GNSS:SVID<ch>:GALileo:NMESsage:FNAV:CCORrection:BGDA:UNSCaled.....	543
[:SOURCE<hw>]:BB:GNSS:SVID<ch>:GALileo:NMESsage:FNAV:CCORrection:TOC.....	540
[:SOURCE<hw>]:BB:GNSS:SVID<ch>:GALileo:NMESsage:FNAV:CCORrection:TOC:UNSCaled.....	540
[:SOURCE<hw>]:BB:GNSS:SVID<ch>:GALileo:NMESsage:FNAV:E5ADVS.....	552
[:SOURCE<hw>]:BB:GNSS:SVID<ch>:GALileo:NMESsage:FNAV:E5AHS.....	552
[:SOURCE<hw>]:BB:GNSS:SVID<ch>:GALileo:NMESsage:FNAV:EPHemeris:CIC.....	538
[:SOURCE<hw>]:BB:GNSS:SVID<ch>:GALileo:NMESsage:FNAV:EPHemeris:CIC:UNSCaled.....	538
[:SOURCE<hw>]:BB:GNSS:SVID<ch>:GALileo:NMESsage:FNAV:EPHemeris:CIS.....	539
[:SOURCE<hw>]:BB:GNSS:SVID<ch>:GALileo:NMESsage:FNAV:EPHemeris:CIS:UNSCaled.....	539
[:SOURCE<hw>]:BB:GNSS:SVID<ch>:GALileo:NMESsage:FNAV:EPHemeris:CRC.....	536
[:SOURCE<hw>]:BB:GNSS:SVID<ch>:GALileo:NMESsage:FNAV:EPHemeris:CRC:UNSCaled.....	536
[:SOURCE<hw>]:BB:GNSS:SVID<ch>:GALileo:NMESsage:FNAV:EPHemeris:CRS.....	537
[:SOURCE<hw>]:BB:GNSS:SVID<ch>:GALileo:NMESsage:FNAV:EPHemeris:CRS:UNSCaled.....	537
[:SOURCE<hw>]:BB:GNSS:SVID<ch>:GALileo:NMESsage:FNAV:EPHemeris:CUC.....	534
[:SOURCE<hw>]:BB:GNSS:SVID<ch>:GALileo:NMESsage:FNAV:EPHemeris:CUC:UNSCaled.....	534
[:SOURCE<hw>]:BB:GNSS:SVID<ch>:GALileo:NMESsage:FNAV:EPHemeris:CUS.....	535
[:SOURCE<hw>]:BB:GNSS:SVID<ch>:GALileo:NMESsage:FNAV:EPHemeris:CUS:UNSCaled.....	535
[:SOURCE<hw>]:BB:GNSS:SVID<ch>:GALileo:NMESsage:FNAV:EPHemeris:ECCentricity.....	523
[:SOURCE<hw>]:BB:GNSS:SVID<ch>:GALileo:NMESsage:FNAV:EPHemeris:ECCentricity:UNSCaled....	523
[:SOURCE<hw>]:BB:GNSS:SVID<ch>:GALileo:NMESsage:FNAV:EPHemeris:IDOT.....	528
[:SOURCE<hw>]:BB:GNSS:SVID<ch>:GALileo:NMESsage:FNAV:EPHemeris:IDOT:UNSCaled.....	528
[:SOURCE<hw>]:BB:GNSS:SVID<ch>:GALileo:NMESsage:FNAV:EPHemeris:IODNav.....	521
[:SOURCE<hw>]:BB:GNSS:SVID<ch>:GALileo:NMESsage:FNAV:EPHemeris:IZERo.....	524
[:SOURCE<hw>]:BB:GNSS:SVID<ch>:GALileo:NMESsage:FNAV:EPHemeris:IZERo:UNSCaled.....	524
[:SOURCE<hw>]:BB:GNSS:SVID<ch>:GALileo:NMESsage:FNAV:EPHemeris:MZERo.....	527
[:SOURCE<hw>]:BB:GNSS:SVID<ch>:GALileo:NMESsage:FNAV:EPHemeris:MZERo:UNSCaled.....	527
[:SOURCE<hw>]:BB:GNSS:SVID<ch>:GALileo:NMESsage:FNAV:EPHemeris:NDELta.....	530
[:SOURCE<hw>]:BB:GNSS:SVID<ch>:GALileo:NMESsage:FNAV:EPHemeris:NDELta:UNSCaled.....	530
[:SOURCE<hw>]:BB:GNSS:SVID<ch>:GALileo:NMESsage:FNAV:EPHemeris:ODOT.....	529
[:SOURCE<hw>]:BB:GNSS:SVID<ch>:GALileo:NMESsage:FNAV:EPHemeris:ODOT:UNSCaled.....	529
[:SOURCE<hw>]:BB:GNSS:SVID<ch>:GALileo:NMESsage:FNAV:EPHemeris:OMEGa.....	526
[:SOURCE<hw>]:BB:GNSS:SVID<ch>:GALileo:NMESsage:FNAV:EPHemeris:OMEGa:UNSCaled.....	526
[:SOURCE<hw>]:BB:GNSS:SVID<ch>:GALileo:NMESsage:FNAV:EPHemeris:OZERo.....	525
[:SOURCE<hw>]:BB:GNSS:SVID<ch>:GALileo:NMESsage:FNAV:EPHemeris:OZERo:UNSCaled.....	525
[:SOURCE<hw>]:BB:GNSS:SVID<ch>:GALileo:NMESsage:FNAV:EPHemeris:SISA.....	549
[:SOURCE<hw>]:BB:GNSS:SVID<ch>:GALileo:NMESsage:FNAV:EPHemeris:SQRA.....	522
[:SOURCE<hw>]:BB:GNSS:SVID<ch>:GALileo:NMESsage:FNAV:EPHemeris:SQRA:UNSCaled.....	522
[:SOURCE<hw>]:BB:GNSS:SVID<ch>:GALileo:NMESsage:FNAV:EPHemeris:TOE.....	521
[:SOURCE<hw>]:BB:GNSS:SVID<ch>:GALileo:NMESsage:FNAV:EPHemeris:TOE:UNSCaled.....	521
[:SOURCE<hw>]:BB:GNSS:SVID<ch>:GALileo:NMESsage:INAV:CCORrection:AF<s2us0>.....	541
[:SOURCE<hw>]:BB:GNSS:SVID<ch>:GALileo:NMESsage:INAV:CCORrection:AF<s2us0>:UNSCaled....	541
[:SOURCE<hw>]:BB:GNSS:SVID<ch>:GALileo:NMESsage:INAV:CCORrection:BGDA.....	544
[:SOURCE<hw>]:BB:GNSS:SVID<ch>:GALileo:NMESsage:INAV:CCORrection:BGDA:UNSCaled.....	544
[:SOURCE<hw>]:BB:GNSS:SVID<ch>:GALileo:NMESsage:INAV:CCORrection:BGDB.....	543
[:SOURCE<hw>]:BB:GNSS:SVID<ch>:GALileo:NMESsage:INAV:CCORrection:BGDB:UNSCaled.....	543
[:SOURCE<hw>]:BB:GNSS:SVID<ch>:GALileo:NMESsage:INAV:CCORrection:TOC.....	540
[:SOURCE<hw>]:BB:GNSS:SVID<ch>:GALileo:NMESsage:INAV:CCORrection:TOC:UNSCaled.....	540

[SOURce<hw>]:BB:GNSS:SVID<ch>:GALileo:NMESsage:INAV:E1BDVS.....	550
[SOURce<hw>]:BB:GNSS:SVID<ch>:GALileo:NMESsage:INAV:E1BHS.....	550
[SOURce<hw>]:BB:GNSS:SVID<ch>:GALileo:NMESsage:INAV:E5BDVS.....	550
[SOURce<hw>]:BB:GNSS:SVID<ch>:GALileo:NMESsage:INAV:E5BHS.....	550
[SOURce<hw>]:BB:GNSS:SVID<ch>:GALileo:NMESsage:INAV:EPHemeris:CIC.....	538
[SOURce<hw>]:BB:GNSS:SVID<ch>:GALileo:NMESsage:INAV:EPHemeris:CIC:UNSCaled.....	538
[SOURce<hw>]:BB:GNSS:SVID<ch>:GALileo:NMESsage:INAV:EPHemeris:CIS.....	539
[SOURce<hw>]:BB:GNSS:SVID<ch>:GALileo:NMESsage:INAV:EPHemeris:CIS:UNSCaled.....	539
[SOURce<hw>]:BB:GNSS:SVID<ch>:GALileo:NMESsage:INAV:EPHemeris:CRC.....	536
[SOURce<hw>]:BB:GNSS:SVID<ch>:GALileo:NMESsage:INAV:EPHemeris:CRC:UNSCaled.....	536
[SOURce<hw>]:BB:GNSS:SVID<ch>:GALileo:NMESsage:INAV:EPHemeris:CRS.....	537
[SOURce<hw>]:BB:GNSS:SVID<ch>:GALileo:NMESsage:INAV:EPHemeris:CRS:UNSCaled.....	537
[SOURce<hw>]:BB:GNSS:SVID<ch>:GALileo:NMESsage:INAV:EPHemeris:CUC.....	535
[SOURce<hw>]:BB:GNSS:SVID<ch>:GALileo:NMESsage:INAV:EPHemeris:CUC:UNSCaled.....	534
[SOURce<hw>]:BB:GNSS:SVID<ch>:GALileo:NMESsage:INAV:EPHemeris:CUS.....	535
[SOURce<hw>]:BB:GNSS:SVID<ch>:GALileo:NMESsage:INAV:EPHemeris:CUS:UNSCaled.....	535
[SOURce<hw>]:BB:GNSS:SVID<ch>:GALileo:NMESsage:INAV:EPHemeris:ECCentricity.....	523
[SOURce<hw>]:BB:GNSS:SVID<ch>:GALileo:NMESsage:INAV:EPHemeris:ECCentricity:UNSCaled.....	523
[SOURce<hw>]:BB:GNSS:SVID<ch>:GALileo:NMESsage:INAV:EPHemeris:IDOT.....	528
[SOURce<hw>]:BB:GNSS:SVID<ch>:GALileo:NMESsage:INAV:EPHemeris:IDOT:UNSCaled.....	528
[SOURce<hw>]:BB:GNSS:SVID<ch>:GALileo:NMESsage:INAV:EPHemeris:IODNav.....	521
[SOURce<hw>]:BB:GNSS:SVID<ch>:GALileo:NMESsage:INAV:EPHemeris:IZERo.....	524
[SOURce<hw>]:BB:GNSS:SVID<ch>:GALileo:NMESsage:INAV:EPHemeris:IZERo:UNSCaled.....	524
[SOURce<hw>]:BB:GNSS:SVID<ch>:GALileo:NMESsage:INAV:EPHemeris:MZERo.....	527
[SOURce<hw>]:BB:GNSS:SVID<ch>:GALileo:NMESsage:INAV:EPHemeris:MZERo:UNSCaled.....	527
[SOURce<hw>]:BB:GNSS:SVID<ch>:GALileo:NMESsage:INAV:EPHemeris:NDELta.....	530
[SOURce<hw>]:BB:GNSS:SVID<ch>:GALileo:NMESsage:INAV:EPHemeris:NDELta:UNSCaled.....	530
[SOURce<hw>]:BB:GNSS:SVID<ch>:GALileo:NMESsage:INAV:EPHemeris:ODOT.....	529
[SOURce<hw>]:BB:GNSS:SVID<ch>:GALileo:NMESsage:INAV:EPHemeris:ODOT:UNSCaled.....	529
[SOURce<hw>]:BB:GNSS:SVID<ch>:GALileo:NMESsage:INAV:EPHemeris:OMEGa.....	526
[SOURce<hw>]:BB:GNSS:SVID<ch>:GALileo:NMESsage:INAV:EPHemeris:OMEGa:UNSCaled.....	526
[SOURce<hw>]:BB:GNSS:SVID<ch>:GALileo:NMESsage:INAV:EPHemeris:OZERo.....	525
[SOURce<hw>]:BB:GNSS:SVID<ch>:GALileo:NMESsage:INAV:EPHemeris:OZERo:UNSCaled.....	525
[SOURce<hw>]:BB:GNSS:SVID<ch>:GALileo:NMESsage:INAV:EPHemeris:SAR:MODE.....	550
[SOURce<hw>]:BB:GNSS:SVID<ch>:GALileo:NMESsage:INAV:EPHemeris:SAR:RLM<s2us>.....	551
[SOURce<hw>]:BB:GNSS:SVID<ch>:GALileo:NMESsage:INAV:EPHemeris:SAR:SPARe.....	551
[SOURce<hw>]:BB:GNSS:SVID<ch>:GALileo:NMESsage:INAV:EPHemeris:SISA.....	549
[SOURce<hw>]:BB:GNSS:SVID<ch>:GALileo:NMESsage:INAV:EPHemeris:SQRA.....	522
[SOURce<hw>]:BB:GNSS:SVID<ch>:GALileo:NMESsage:INAV:EPHemeris:SQRA:UNSCaled.....	522
[SOURce<hw>]:BB:GNSS:SVID<ch>:GALileo:NMESsage:INAV:EPHemeris:TOE.....	522
[SOURce<hw>]:BB:GNSS:SVID<ch>:GALileo:NMESsage:INAV:EPHemeris:TOE:UNSCaled.....	522
[SOURce<hw>]:BB:GNSS:SVID<ch>:GALileo:POWER:COPY:EXECute.....	463
[SOURce<hw>]:BB:GNSS:SVID<ch>:GALileo:POWER:COPY:SVID.....	462
[SOURce<hw>]:BB:GNSS:SVID<ch>:GALileo:POWER:OFFSet.....	460
[SOURce<hw>]:BB:GNSS:SVID<ch>:GALileo:POWER:PLOSS.....	460
[SOURce<hw>]:BB:GNSS:SVID<ch>:GALileo:PRERrors:COPY:EXECute.....	495
[SOURce<hw>]:BB:GNSS:SVID<ch>:GALileo:PRERrors:COPY:SVID.....	494
[SOURce<hw>]:BB:GNSS:SVID<ch>:GALileo:PRERrors:FILE.....	494
[SOURce<hw>]:BB:GNSS:SVID<ch>:GALileo:PRERrors:MODE.....	493
[SOURce<hw>]:BB:GNSS:SVID<ch>:GALileo:PRERrors:PROFile:APPend.....	497

[:SOURCE<hw>]:BB:GNSS:SVID<ch>:GALileo:PRERrors:PROFile:COUNT?.....	496
[:SOURCE<hw>]:BB:GNSS:SVID<ch>:GALileo:PRERrors:PROFile:OFFSet.....	496
[:SOURCE<hw>]:BB:GNSS:SVID<ch>:GALileo:PRERrors:PROFile<gr>:DELete.....	499
[:SOURCE<hw>]:BB:GNSS:SVID<ch>:GALileo:PRERrors:PROFile<gr>:INSert.....	499
[:SOURCE<hw>]:BB:GNSS:SVID<ch>:GALileo:PRERrors:PROFile<gr>:REFerence.....	497
[:SOURCE<hw>]:BB:GNSS:SVID<ch>:GALileo:PRERrors:PROFile<gr>:VALue.....	498
[:SOURCE<hw>]:BB:GNSS:SVID<ch>:GALileo:PRERrors:VALue.....	495
[:SOURCE<hw>]:BB:GNSS:SVID<ch>:GALileo:PRESEnt.....	459
[:SOURCE<hw>]:BB:GNSS:SVID<ch>:GALileo:SDYNameics:ACCel:MAX.....	595
[:SOURCE<hw>]:BB:GNSS:SVID<ch>:GALileo:SDYNameics:CAPeriod.....	594
[:SOURCE<hw>]:BB:GNSS:SVID<ch>:GALileo:SDYNameics:CONFig.....	593
[:SOURCE<hw>]:BB:GNSS:SVID<ch>:GALileo:SDYNameics:CPHase.....	591
[:SOURCE<hw>]:BB:GNSS:SVID<ch>:GALileo:SDYNameics:CVPeriod.....	594
[:SOURCE<hw>]:BB:GNSS:SVID<ch>:GALileo:SDYNameics:IVELocity.....	593
[:SOURCE<hw>]:BB:GNSS:SVID<ch>:GALileo:SDYNameics:JERK:MAX.....	595
[:SOURCE<hw>]:BB:GNSS:SVID<ch>:GALileo:SDYNameics:PRANge.....	591
[:SOURCE<hw>]:BB:GNSS:SVID<ch>:GALileo:SDYNameics:PROFile.....	590
[:SOURCE<hw>]:BB:GNSS:SVID<ch>:GALileo:SDYNameics:RPERiod?.....	596
[:SOURCE<hw>]:BB:GNSS:SVID<ch>:GALileo:SDYNameics:TOFFset.....	592
[:SOURCE<hw>]:BB:GNSS:SVID<ch>:GALileo:SDYNameics:VELocity.....	592
[:SOURCE<hw>]:BB:GNSS:SVID<ch>:GALileo:SIGNal:L1Band:E1OS:DATA:NMESSage:CONTRol.....	470
[:SOURCE<hw>]:BB:GNSS:SVID<ch>:GALileo:SIGNal:L1Band:E1OS:DATA:NMESSage:DSElect.....	474
[:SOURCE<hw>]:BB:GNSS:SVID<ch>:GALileo:SIGNal:L1Band:E1OS:DATA:NMESSage:PATTERn.....	475
[:SOURCE<hw>]:BB:GNSS:SVID<ch>:GALileo:SIGNal:L1Band:E1OS:DATA:NMESSage:TYPE.....	472
[:SOURCE<hw>]:BB:GNSS:SVID<ch>:GALileo:SIGNal:L1Band:E1OS:DATA:NMESSage[:STATe].....	589
[:SOURCE<hw>]:BB:GNSS:SVID<ch>:GALileo:SIGNal:L1Band:E1OS:DATA:OSNMA[:STATe].....	474
[:SOURCE<hw>]:BB:GNSS:SVID<ch>:GALileo:SIGNal:L1Band:E1OS:DATA:PCODE[:STATe].....	466
[:SOURCE<hw>]:BB:GNSS:SVID<ch>:GALileo:SIGNal:L1Band:E1OS:DATA:SCODE[:STATe].....	468
[:SOURCE<hw>]:BB:GNSS:SVID<ch>:GALileo:SIGNal:L1Band:E1OS:PILOT:PCODE[:STATe].....	466
[:SOURCE<hw>]:BB:GNSS:SVID<ch>:GALileo:SIGNal:L1Band:E1OS:PILOT:SCODE[:STATe].....	468
[:SOURCE<hw>]:BB:GNSS:SVID<ch>:GALileo:SIGNal:L1Band:E1OS:POWER:OFFset.....	461
[:SOURCE<hw>]:BB:GNSS:SVID<ch>:GALileo:SIGNal:L1Band:E1OS[:STATe].....	464
[:SOURCE<hw>]:BB:GNSS:SVID<ch>:GALileo:SIGNal:L1Band:E1PRs:DATA:NMESSage:CONTRol.....	470
[:SOURCE<hw>]:BB:GNSS:SVID<ch>:GALileo:SIGNal:L1Band:E1PRs:DATA:NMESSage:DSElect.....	474
[:SOURCE<hw>]:BB:GNSS:SVID<ch>:GALileo:SIGNal:L1Band:E1PRs:DATA:NMESSage:PATTERn.....	475
[:SOURCE<hw>]:BB:GNSS:SVID<ch>:GALileo:SIGNal:L1Band:E1PRs:DATA:NMESSage:TYPE.....	472
[:SOURCE<hw>]:BB:GNSS:SVID<ch>:GALileo:SIGNal:L1Band:E1PRs:DATA:NMESSage[:STATe].....	589
[:SOURCE<hw>]:BB:GNSS:SVID<ch>:GALileo:SIGNal:L1Band:E1PRs:DATA:PCODE[:STATe].....	466
[:SOURCE<hw>]:BB:GNSS:SVID<ch>:GALileo:SIGNal:L1Band:E1PRs:DATA:SCODE[:STATe].....	468
[:SOURCE<hw>]:BB:GNSS:SVID<ch>:GALileo:SIGNal:L1Band:E1PRs:POWER:OFFset.....	461
[:SOURCE<hw>]:BB:GNSS:SVID<ch>:GALileo:SIGNal:L1Band:E1PRs[:STATe].....	464
[:SOURCE<hw>]:BB:GNSS:SVID<ch>:GALileo:SIGNal:L2Band:E6PRs:DATA:NMESSage:CONTRol.....	470
[:SOURCE<hw>]:BB:GNSS:SVID<ch>:GALileo:SIGNal:L2Band:E6PRs:DATA:NMESSage:DSElect.....	473
[:SOURCE<hw>]:BB:GNSS:SVID<ch>:GALileo:SIGNal:L2Band:E6PRs:DATA:NMESSage:PATTERn.....	475
[:SOURCE<hw>]:BB:GNSS:SVID<ch>:GALileo:SIGNal:L2Band:E6PRs:DATA:NMESSage:TYPE.....	471
[:SOURCE<hw>]:BB:GNSS:SVID<ch>:GALileo:SIGNal:L2Band:E6PRs:DATA:NMESSage[:STATe].....	589
[:SOURCE<hw>]:BB:GNSS:SVID<ch>:GALileo:SIGNal:L2Band:E6PRs:DATA:PCODE[:STATe].....	466
[:SOURCE<hw>]:BB:GNSS:SVID<ch>:GALileo:SIGNal:L2Band:E6PRs:DATA:SCODE[:STATe].....	468
[:SOURCE<hw>]:BB:GNSS:SVID<ch>:GALileo:SIGNal:L2Band:E6PRs:POWER:OFFset.....	461
[:SOURCE<hw>]:BB:GNSS:SVID<ch>:GALileo:SIGNal:L2Band:E6PRs[:STATe].....	464

[:SOURCE<hw>]:BB:GNSS:SVID<ch>:GALileo:SIGNal:L2Band:E6S:DATA:NMESSage:CONTRol.....	470
[:SOURCE<hw>]:BB:GNSS:SVID<ch>:GALileo:SIGNal:L2Band:E6S:DATA:NMESSage:DSElect.....	473
[:SOURCE<hw>]:BB:GNSS:SVID<ch>:GALileo:SIGNal:L2Band:E6S:DATA:NMESSage:PATTErn.....	475
[:SOURCE<hw>]:BB:GNSS:SVID<ch>:GALileo:SIGNal:L2Band:E6S:DATA:NMESSage:TYPE.....	471
[:SOURCE<hw>]:BB:GNSS:SVID<ch>:GALileo:SIGNal:L2Band:E6S:DATA:NMESSage[:STATe].....	589
[:SOURCE<hw>]:BB:GNSS:SVID<ch>:GALileo:SIGNal:L2Band:E6S:DATA:PCODE[:STATe].....	466
[:SOURCE<hw>]:BB:GNSS:SVID<ch>:GALileo:SIGNal:L2Band:E6S:PILOt:PCODE[:STATe].....	466
[:SOURCE<hw>]:BB:GNSS:SVID<ch>:GALileo:SIGNal:L2Band:E6S:PILOt:SCODE[:STATe].....	468
[:SOURCE<hw>]:BB:GNSS:SVID<ch>:GALileo:SIGNal:L2Band:E6S:POWEr:OFFset.....	461
[:SOURCE<hw>]:BB:GNSS:SVID<ch>:GALileo:SIGNal:L2Band:E6S[:STATe].....	464
[:SOURCE<hw>]:BB:GNSS:SVID<ch>:GALileo:SIGNal:L5Band:E5A:DATA:NMESSage:CONTRol.....	470
[:SOURCE<hw>]:BB:GNSS:SVID<ch>:GALileo:SIGNal:L5Band:E5A:DATA:NMESSage:DSElect.....	473
[:SOURCE<hw>]:BB:GNSS:SVID<ch>:GALileo:SIGNal:L5Band:E5A:DATA:NMESSage:PATTErn.....	475
[:SOURCE<hw>]:BB:GNSS:SVID<ch>:GALileo:SIGNal:L5Band:E5A:DATA:NMESSage:TYPE.....	471
[:SOURCE<hw>]:BB:GNSS:SVID<ch>:GALileo:SIGNal:L5Band:E5A:DATA:NMESSage[:STATe].....	589
[:SOURCE<hw>]:BB:GNSS:SVID<ch>:GALileo:SIGNal:L5Band:E5A:DATA:PCODE[:STATe].....	466
[:SOURCE<hw>]:BB:GNSS:SVID<ch>:GALileo:SIGNal:L5Band:E5A:DATA:SCODE[:STATe].....	468
[:SOURCE<hw>]:BB:GNSS:SVID<ch>:GALileo:SIGNal:L5Band:E5A:PILOt:PCODE[:STATe].....	466
[:SOURCE<hw>]:BB:GNSS:SVID<ch>:GALileo:SIGNal:L5Band:E5A:PILOt:SCODE[:STATe].....	468
[:SOURCE<hw>]:BB:GNSS:SVID<ch>:GALileo:SIGNal:L5Band:E5A:POWEr:OFFset.....	461
[:SOURCE<hw>]:BB:GNSS:SVID<ch>:GALileo:SIGNal:L5Band:E5A[:STATe].....	464
[:SOURCE<hw>]:BB:GNSS:SVID<ch>:GALileo:SIGNal:L5Band:E5B:DATA:NMESSage:CONTRol.....	470
[:SOURCE<hw>]:BB:GNSS:SVID<ch>:GALileo:SIGNal:L5Band:E5B:DATA:NMESSage:DSElect.....	473
[:SOURCE<hw>]:BB:GNSS:SVID<ch>:GALileo:SIGNal:L5Band:E5B:DATA:NMESSage:PATTErn.....	475
[:SOURCE<hw>]:BB:GNSS:SVID<ch>:GALileo:SIGNal:L5Band:E5B:DATA:NMESSage:TYPE.....	471
[:SOURCE<hw>]:BB:GNSS:SVID<ch>:GALileo:SIGNal:L5Band:E5B:DATA:NMESSage[:STATe].....	589
[:SOURCE<hw>]:BB:GNSS:SVID<ch>:GALileo:SIGNal:L5Band:E5B:DATA:PCODE[:STATe].....	466
[:SOURCE<hw>]:BB:GNSS:SVID<ch>:GALileo:SIGNal:L5Band:E5B:DATA:SCODE[:STATe].....	468
[:SOURCE<hw>]:BB:GNSS:SVID<ch>:GALileo:SIGNal:L5Band:E5B:PILOt:PCODE[:STATe].....	466
[:SOURCE<hw>]:BB:GNSS:SVID<ch>:GALileo:SIGNal:L5Band:E5B:PILOt:SCODE[:STATe].....	468
[:SOURCE<hw>]:BB:GNSS:SVID<ch>:GALileo:SIGNal:L5Band:E5B:POWEr:OFFset.....	461
[:SOURCE<hw>]:BB:GNSS:SVID<ch>:GALileo:SIGNal:L5Band:E5B[:STATe].....	464
[:SOURCE<hw>]:BB:GNSS:SVID<ch>:GALileo:SIMulated:CLOCK:AF<s2us0>.....	490
[:SOURCE<hw>]:BB:GNSS:SVID<ch>:GALileo:SIMulated:CLOCK:TGD.....	491
[:SOURCE<hw>]:BB:GNSS:SVID<ch>:GALileo:SIMulated:CLOCK:TOC.....	490
[:SOURCE<hw>]:BB:GNSS:SVID<ch>:GALileo:SIMulated:CLOCK:WNOC.....	490
[:SOURCE<hw>]:BB:GNSS:SVID<ch>:GALileo:SIMulated:ORBit:CIC.....	489
[:SOURCE<hw>]:BB:GNSS:SVID<ch>:GALileo:SIMulated:ORBit:CIS.....	489
[:SOURCE<hw>]:BB:GNSS:SVID<ch>:GALileo:SIMulated:ORBit:CRC.....	489
[:SOURCE<hw>]:BB:GNSS:SVID<ch>:GALileo:SIMulated:ORBit:CRS.....	489
[:SOURCE<hw>]:BB:GNSS:SVID<ch>:GALileo:SIMulated:ORBit:CUC.....	488
[:SOURCE<hw>]:BB:GNSS:SVID<ch>:GALileo:SIMulated:ORBit:CUS.....	488
[:SOURCE<hw>]:BB:GNSS:SVID<ch>:GALileo:SIMulated:ORBit:ECCentricity.....	486
[:SOURCE<hw>]:BB:GNSS:SVID<ch>:GALileo:SIMulated:ORBit:IDOT.....	487
[:SOURCE<hw>]:BB:GNSS:SVID<ch>:GALileo:SIMulated:ORBit:IZERo.....	486
[:SOURCE<hw>]:BB:GNSS:SVID<ch>:GALileo:SIMulated:ORBit:MZERo.....	487
[:SOURCE<hw>]:BB:GNSS:SVID<ch>:GALileo:SIMulated:ORBit:NDELta.....	488
[:SOURCE<hw>]:BB:GNSS:SVID<ch>:GALileo:SIMulated:ORBit:ODOT.....	488
[:SOURCE<hw>]:BB:GNSS:SVID<ch>:GALileo:SIMulated:ORBit:OMEGa.....	487
[:SOURCE<hw>]:BB:GNSS:SVID<ch>:GALileo:SIMulated:ORBit:OZERo.....	486

[:SOURCE<hw>]:BB:GNSS:SVID<ch>:GALileo:SIMulated:ORBit:SQRA.....	486
[:SOURCE<hw>]:BB:GNSS:SVID<ch>:GALileo:SIMulated:ORBit:TOE.....	484
[:SOURCE<hw>]:BB:GNSS:SVID<ch>:GALileo:SIMulated:ORBit:WNOE.....	484
[:SOURCE<hw>]:BB:GNSS:SVID<ch>:GALileo:STATe.....	459
[:SOURCE<hw>]:BB:GNSS:SVID<ch>:GALileo:VISibility:STATe?.....	446
[:SOURCE<hw>]:BB:GNSS:SVID<ch>:GLONass:FNUMber.....	459
[:SOURCE<hw>]:BB:GNSS:SVID<ch>:GLONass:HEALthy.....	445
[:SOURCE<hw>]:BB:GNSS:SVID<ch>:GLONass:MCONtrol:COpy:EXECute.....	478
[:SOURCE<hw>]:BB:GNSS:SVID<ch>:GLONass:MCONtrol:COpy:SVID.....	477
[:SOURCE<hw>]:BB:GNSS:SVID<ch>:GLONass:MPATH[:V<us>:A<gr>]:ECHO<s2us0>:AAZimuth.....	426
[:SOURCE<hw>]:BB:GNSS:SVID<ch>:GLONass:MPATH[:V<us>:A<gr>]:ECHO<s2us0>:AELEVation.....	427
[:SOURCE<hw>]:BB:GNSS:SVID<ch>:GLONass:MPATH[:V<us>:A<gr>]:ECHO<s2us0>:CPDRift.....	423
[:SOURCE<hw>]:BB:GNSS:SVID<ch>:GLONass:MPATH[:V<us>:A<gr>]:ECHO<s2us0>:CPHase.....	425
[:SOURCE<hw>]:BB:GNSS:SVID<ch>:GLONass:MPATH[:V<us>:A<gr>]:ECHO<s2us0>:DSHift.....	426
[:SOURCE<hw>]:BB:GNSS:SVID<ch>:GLONass:MPATH[:V<us>:A<gr>]:ECHO<s2us0>:ICPHase.....	422
[:SOURCE<hw>]:BB:GNSS:SVID<ch>:GLONass:MPATH[:V<us>:A<gr>]:ECHO<s2us0>:POWEr.....	424
[:SOURCE<hw>]:BB:GNSS:SVID<ch>:GLONass:MPATH[:V<us>:A<gr>]:ECHos:COUNT.....	422
[:SOURCE<hw>]:BB:GNSS:SVID<ch>:GLONass:MPATH[:V<us>:A<gr>]:LOS:AAZimuth?.....	426
[:SOURCE<hw>]:BB:GNSS:SVID<ch>:GLONass:MPATH[:V<us>:A<gr>]:LOS:AELEVation?.....	427
[:SOURCE<hw>]:BB:GNSS:SVID<ch>:GLONass:MPATH[:V<us>:A<gr>]:LOS:CPDRift?.....	423
[:SOURCE<hw>]:BB:GNSS:SVID<ch>:GLONass:MPATH[:V<us>:A<gr>]:LOS:CPHase?.....	425
[:SOURCE<hw>]:BB:GNSS:SVID<ch>:GLONass:MPATH[:V<us>:A<gr>]:LOS:DSHift?.....	425
[:SOURCE<hw>]:BB:GNSS:SVID<ch>:GLONass:MPATH[:V<us>:A<gr>]:LOS:ENABLE.....	421
[:SOURCE<hw>]:BB:GNSS:SVID<ch>:GLONass:MPATH[:V<us>:A<gr>]:LOS:ICPHase?.....	422
[:SOURCE<hw>]:BB:GNSS:SVID<ch>:GLONass:MPATH[:V<us>:A<gr>]:LOS:POWEr?.....	424
[:SOURCE<hw>]:BB:GNSS:SVID<ch>:GLONass:NMESsage:NAV:CCORrection:DTAU.....	544
[:SOURCE<hw>]:BB:GNSS:SVID<ch>:GLONass:NMESsage:NAV:CCORrection:DTAU:UNSCaled.....	544
[:SOURCE<hw>]:BB:GNSS:SVID<ch>:GLONass:NMESsage:NAV:CCORrection:EN.....	553
[:SOURCE<hw>]:BB:GNSS:SVID<ch>:GLONass:NMESsage:NAV:CCORrection:GAMN.....	544
[:SOURCE<hw>]:BB:GNSS:SVID<ch>:GLONass:NMESsage:NAV:CCORrection:GAMN:UNSCaled.....	544
[:SOURCE<hw>]:BB:GNSS:SVID<ch>:GLONass:NMESsage:NAV:CCORrection:TAUN.....	544
[:SOURCE<hw>]:BB:GNSS:SVID<ch>:GLONass:NMESsage:NAV:CCORrection:TAUN:UNSCaled.....	544
[:SOURCE<hw>]:BB:GNSS:SVID<ch>:GLONass:NMESsage:NAV:EPHemeris:AOEP.....	553
[:SOURCE<hw>]:BB:GNSS:SVID<ch>:GLONass:NMESsage:NAV:EPHemeris:CFM.....	552
[:SOURCE<hw>]:BB:GNSS:SVID<ch>:GLONass:NMESsage:NAV:EPHemeris:HEALth.....	547
[:SOURCE<hw>]:BB:GNSS:SVID<ch>:GLONass:NMESsage:NAV:EPHemeris:P.....	552
[:SOURCE<hw>]:BB:GNSS:SVID<ch>:GLONass:NMESsage:NAV:EPHemeris:SEType.....	552
[:SOURCE<hw>]:BB:GNSS:SVID<ch>:GLONass:NMESsage:NAV:EPHemeris:TALignment.....	553
[:SOURCE<hw>]:BB:GNSS:SVID<ch>:GLONass:NMESsage:NAV:EPHemeris:TINdex.....	532
[:SOURCE<hw>]:BB:GNSS:SVID<ch>:GLONass:NMESsage:NAV:EPHemeris:TINdex:UNSCaled.....	532
[:SOURCE<hw>]:BB:GNSS:SVID<ch>:GLONass:NMESsage:NAV:EPHemeris:TINterval?.....	532
[:SOURCE<hw>]:BB:GNSS:SVID<ch>:GLONass:NMESsage:NAV:EPHemeris:TOE?.....	532
[:SOURCE<hw>]:BB:GNSS:SVID<ch>:GLONass:NMESsage:NAV:EPHemeris:URA.....	547
[:SOURCE<hw>]:BB:GNSS:SVID<ch>:GLONass:NMESsage:NAV:EPHemeris:XDDN.....	534
[:SOURCE<hw>]:BB:GNSS:SVID<ch>:GLONass:NMESsage:NAV:EPHemeris:XDDN:UNSCaled.....	534
[:SOURCE<hw>]:BB:GNSS:SVID<ch>:GLONass:NMESsage:NAV:EPHemeris:XDN.....	533
[:SOURCE<hw>]:BB:GNSS:SVID<ch>:GLONass:NMESsage:NAV:EPHemeris:XDN:UNSCaled.....	533
[:SOURCE<hw>]:BB:GNSS:SVID<ch>:GLONass:NMESsage:NAV:EPHemeris:XM.....	533
[:SOURCE<hw>]:BB:GNSS:SVID<ch>:GLONass:NMESsage:NAV:EPHemeris:XM:UNSCaled.....	533
[:SOURCE<hw>]:BB:GNSS:SVID<ch>:GLONass:NMESsage:NAV:EPHemeris:YDDN.....	534

[:SOURce<hw>]:BB:GNSS:SVID<ch>:GLONass:NMESsage:NAV:EPHemeris:YDDN:UNSCaled.....	534
[:SOURce<hw>]:BB:GNSS:SVID<ch>:GLONass:NMESsage:NAV:EPHemeris:YDN.....	533
[:SOURce<hw>]:BB:GNSS:SVID<ch>:GLONass:NMESsage:NAV:EPHemeris:YDN:UNSCaled.....	533
[:SOURce<hw>]:BB:GNSS:SVID<ch>:GLONass:NMESsage:NAV:EPHemeris:YN.....	533
[:SOURce<hw>]:BB:GNSS:SVID<ch>:GLONass:NMESsage:NAV:EPHemeris:YN:UNSCaled.....	533
[:SOURce<hw>]:BB:GNSS:SVID<ch>:GLONass:NMESsage:NAV:EPHemeris:ZDDN.....	534
[:SOURce<hw>]:BB:GNSS:SVID<ch>:GLONass:NMESsage:NAV:EPHemeris:ZDDN:UNSCaled.....	534
[:SOURce<hw>]:BB:GNSS:SVID<ch>:GLONass:NMESsage:NAV:EPHemeris:ZDN.....	533
[:SOURce<hw>]:BB:GNSS:SVID<ch>:GLONass:NMESsage:NAV:EPHemeris:ZDN:UNSCaled.....	533
[:SOURce<hw>]:BB:GNSS:SVID<ch>:GLONass:NMESsage:NAV:EPHemeris:ZN.....	533
[:SOURce<hw>]:BB:GNSS:SVID<ch>:GLONass:NMESsage:NAV:EPHemeris:ZN:UNSCaled.....	532
[:SOURce<hw>]:BB:GNSS:SVID<ch>:GLONass:POWEr:COPI:EXECute.....	463
[:SOURce<hw>]:BB:GNSS:SVID<ch>:GLONass:POWEr:COPI:SVID.....	462
[:SOURce<hw>]:BB:GNSS:SVID<ch>:GLONass:POWEr:OFFSet.....	460
[:SOURce<hw>]:BB:GNSS:SVID<ch>:GLONass:POWEr:PLOSS.....	460
[:SOURce<hw>]:BB:GNSS:SVID<ch>:GLONass:PRERrors:COPI:EXECute.....	495
[:SOURce<hw>]:BB:GNSS:SVID<ch>:GLONass:PRERrors:COPI:SVID.....	494
[:SOURce<hw>]:BB:GNSS:SVID<ch>:GLONass:PRERrors:FILE.....	494
[:SOURce<hw>]:BB:GNSS:SVID<ch>:GLONass:PRERrors:MODE.....	493
[:SOURce<hw>]:BB:GNSS:SVID<ch>:GLONass:PRERrors:PROFile:APPend.....	497
[:SOURce<hw>]:BB:GNSS:SVID<ch>:GLONass:PRERrors:PROFile:COUNt?.....	496
[:SOURce<hw>]:BB:GNSS:SVID<ch>:GLONass:PRERrors:PROFile:OFFSet.....	496
[:SOURce<hw>]:BB:GNSS:SVID<ch>:GLONass:PRERrors:PROFile<gr>:DELete.....	499
[:SOURce<hw>]:BB:GNSS:SVID<ch>:GLONass:PRERrors:PROFile<gr>:INSert.....	499
[:SOURce<hw>]:BB:GNSS:SVID<ch>:GLONass:PRERrors:PROFile<gr>:REFerence.....	497
[:SOURce<hw>]:BB:GNSS:SVID<ch>:GLONass:PRERrors:PROFile<gr>:REFerence.....	497
[:SOURce<hw>]:BB:GNSS:SVID<ch>:GLONass:PRERrors:PROFile<gr>:VALue.....	498
[:SOURce<hw>]:BB:GNSS:SVID<ch>:GLONass:PRERrors:VALue.....	495
[:SOURce<hw>]:BB:GNSS:SVID<ch>:GLONass:PRESent.....	459
[:SOURce<hw>]:BB:GNSS:SVID<ch>:GLONass:SDYNameics:ACCel:MAX.....	595
[:SOURce<hw>]:BB:GNSS:SVID<ch>:GLONass:SDYNameics:CAPeriod.....	594
[:SOURce<hw>]:BB:GNSS:SVID<ch>:GLONass:SDYNameics:CONFig.....	593
[:SOURce<hw>]:BB:GNSS:SVID<ch>:GLONass:SDYNameics:CPHase.....	591
[:SOURce<hw>]:BB:GNSS:SVID<ch>:GLONass:SDYNameics:CVPeriod.....	594
[:SOURce<hw>]:BB:GNSS:SVID<ch>:GLONass:SDYNameics:IVELocity.....	593
[:SOURce<hw>]:BB:GNSS:SVID<ch>:GLONass:SDYNameics:JERK:MAX.....	595
[:SOURce<hw>]:BB:GNSS:SVID<ch>:GLONass:SDYNameics:PRANge.....	591
[:SOURce<hw>]:BB:GNSS:SVID<ch>:GLONass:SDYNameics:PROFile.....	590
[:SOURce<hw>]:BB:GNSS:SVID<ch>:GLONass:SDYNameics:RPERiod?.....	596
[:SOURce<hw>]:BB:GNSS:SVID<ch>:GLONass:SDYNameics:TOFFset.....	592
[:SOURce<hw>]:BB:GNSS:SVID<ch>:GLONass:SDYNameics:VELocity.....	592
[:SOURce<hw>]:BB:GNSS:SVID<ch>:GLONass:SIGNal:L1Band:CA:DATA:MEANdering[:STATe].....	476
[:SOURce<hw>]:BB:GNSS:SVID<ch>:GLONass:SIGNal:L1Band:CA:DATA:NMESsage:CONTRol.....	469
[:SOURce<hw>]:BB:GNSS:SVID<ch>:GLONass:SIGNal:L1Band:CA:DATA:NMESsage:DSElect.....	473
[:SOURce<hw>]:BB:GNSS:SVID<ch>:GLONass:SIGNal:L1Band:CA:DATA:NMESsage:PATTerN.....	475
[:SOURce<hw>]:BB:GNSS:SVID<ch>:GLONass:SIGNal:L1Band:CA:DATA:NMESsage:TYPE.....	471
[:SOURce<hw>]:BB:GNSS:SVID<ch>:GLONass:SIGNal:L1Band:CA:DATA:NMESsage[:STATe].....	589
[:SOURce<hw>]:BB:GNSS:SVID<ch>:GLONass:SIGNal:L1Band:CA:DATA:PCODE[:STATe].....	466
[:SOURce<hw>]:BB:GNSS:SVID<ch>:GLONass:SIGNal:L1Band:CA:DATA:TSEQUence[:STATe].....	477
[:SOURce<hw>]:BB:GNSS:SVID<ch>:GLONass:SIGNal:L1Band:CA:PILOt:PCODE[:STATe].....	466

[:SOURCE<hw>]:BB:GNSS:SVID<ch>:GLONASS:SIGNAl:L1Band:CA:POWer:OFFset.....	461
[:SOURCE<hw>]:BB:GNSS:SVID<ch>:GLONASS:SIGNAl:L1Band:L1CDma:DATA:NMESSage:CONTRol....	470
[:SOURCE<hw>]:BB:GNSS:SVID<ch>:GLONASS:SIGNAl:L1Band:L1CDma:DATA:NMESSage:DSElect....	473
[:SOURCE<hw>]:BB:GNSS:SVID<ch>:GLONASS:SIGNAl:L1Band:L1CDma:DATA:NMESSage:PATtern....	475
[:SOURCE<hw>]:BB:GNSS:SVID<ch>:GLONASS:SIGNAl:L1Band:L1CDma:DATA:NMESSage:TYPE.....	471
[:SOURCE<hw>]:BB:GNSS:SVID<ch>:GLONASS:SIGNAl:L1Band:L1CDma:DATA:NMESSage[:STATe].....	589
[:SOURCE<hw>]:BB:GNSS:SVID<ch>:GLONASS:SIGNAl:L1Band:L1CDma:DATA:PCODE[:STATe].....	466
[:SOURCE<hw>]:BB:GNSS:SVID<ch>:GLONASS:SIGNAl:L1Band:L1CDma:DATA:SCODE[:STATe].....	468
[:SOURCE<hw>]:BB:GNSS:SVID<ch>:GLONASS:SIGNAl:L1Band:L1CDma:PILOt:PCODE[:STATe].....	466
[:SOURCE<hw>]:BB:GNSS:SVID<ch>:GLONASS:SIGNAl:L1Band:L1CDma:POWer:OFFset.....	461
[:SOURCE<hw>]:BB:GNSS:SVID<ch>:GLONASS:SIGNAl:L1Band:L1CDma[:STATe].....	464
[:SOURCE<hw>]:BB:GNSS:SVID<ch>:GLONASS:SIGNAl:L2Band:CA:DATA:MEANdering[:STATe].....	476
[:SOURCE<hw>]:BB:GNSS:SVID<ch>:GLONASS:SIGNAl:L2Band:CA:DATA:NMESSage:CONTRol.....	469
[:SOURCE<hw>]:BB:GNSS:SVID<ch>:GLONASS:SIGNAl:L2Band:CA:DATA:NMESSage:DSElect.....	473
[:SOURCE<hw>]:BB:GNSS:SVID<ch>:GLONASS:SIGNAl:L2Band:CA:DATA:NMESSage:PATtern.....	475
[:SOURCE<hw>]:BB:GNSS:SVID<ch>:GLONASS:SIGNAl:L2Band:CA:DATA:NMESSage:TYPE.....	471
[:SOURCE<hw>]:BB:GNSS:SVID<ch>:GLONASS:SIGNAl:L2Band:CA:DATA:NMESSage[:STATe].....	589
[:SOURCE<hw>]:BB:GNSS:SVID<ch>:GLONASS:SIGNAl:L2Band:CA:DATA:PCODE[:STATe].....	466
[:SOURCE<hw>]:BB:GNSS:SVID<ch>:GLONASS:SIGNAl:L2Band:CA:DATA:TSEQUence[:STATe].....	477
[:SOURCE<hw>]:BB:GNSS:SVID<ch>:GLONASS:SIGNAl:L2Band:CA:PILOt:PCODE[:STATe].....	466
[:SOURCE<hw>]:BB:GNSS:SVID<ch>:GLONASS:SIGNAl:L2Band:CA:POWer:OFFset.....	461
[:SOURCE<hw>]:BB:GNSS:SVID<ch>:GLONASS:SIGNAl:L2Band:CA[:STATe].....	464
[:SOURCE<hw>]:BB:GNSS:SVID<ch>:GLONASS:SIGNAl:L2Band:L2CDma:DATA:NMESSage:CONTRol....	469
[:SOURCE<hw>]:BB:GNSS:SVID<ch>:GLONASS:SIGNAl:L2Band:L2CDma:DATA:NMESSage:DSElect....	473
[:SOURCE<hw>]:BB:GNSS:SVID<ch>:GLONASS:SIGNAl:L2Band:L2CDma:DATA:NMESSage:PATtern....	475
[:SOURCE<hw>]:BB:GNSS:SVID<ch>:GLONASS:SIGNAl:L2Band:L2CDma:DATA:NMESSage:TYPE.....	471
[:SOURCE<hw>]:BB:GNSS:SVID<ch>:GLONASS:SIGNAl:L2Band:L2CDma:DATA:NMESSage[:STATe].....	589
[:SOURCE<hw>]:BB:GNSS:SVID<ch>:GLONASS:SIGNAl:L2Band:L2CDma:PILOt:PCODE[:STATe].....	466
[:SOURCE<hw>]:BB:GNSS:SVID<ch>:GLONASS:SIGNAl:L2Band:L2CDma:PILOt:SCODE[:STATe].....	468
[:SOURCE<hw>]:BB:GNSS:SVID<ch>:GLONASS:SIGNAl:L2Band:L2CDma:POWer:OFFset.....	461
[:SOURCE<hw>]:BB:GNSS:SVID<ch>:GLONASS:SIGNAl:L2Band:L2CDma[:STATe].....	464
[:SOURCE<hw>]:BB:GNSS:SVID<ch>:GLONASS:SIGNAl:L5Band:L3CDma:DATA:NMESSage:CONTRol....	469
[:SOURCE<hw>]:BB:GNSS:SVID<ch>:GLONASS:SIGNAl:L5Band:L3CDma:DATA:NMESSage:DSElect....	473
[:SOURCE<hw>]:BB:GNSS:SVID<ch>:GLONASS:SIGNAl:L5Band:L3CDma:DATA:NMESSage:PATtern....	475
[:SOURCE<hw>]:BB:GNSS:SVID<ch>:GLONASS:SIGNAl:L5Band:L3CDma:DATA:NMESSage:TYPE.....	471
[:SOURCE<hw>]:BB:GNSS:SVID<ch>:GLONASS:SIGNAl:L5Band:L3CDma:DATA:NMESSage[:STATe].....	589
[:SOURCE<hw>]:BB:GNSS:SVID<ch>:GLONASS:SIGNAl:L5Band:L3CDma:DATA:PCODE[:STATe].....	466
[:SOURCE<hw>]:BB:GNSS:SVID<ch>:GLONASS:SIGNAl:L5Band:L3CDma:DATA:SCODE[:STATe].....	468
[:SOURCE<hw>]:BB:GNSS:SVID<ch>:GLONASS:SIGNAl:L5Band:L3CDma:PILOt:PCODE[:STATe].....	466
[:SOURCE<hw>]:BB:GNSS:SVID<ch>:GLONASS:SIGNAl:L5Band:L3CDma:PILOt:SCODE[:STATe].....	468
[:SOURCE<hw>]:BB:GNSS:SVID<ch>:GLONASS:SIGNAl:L5Band:L3CDma:POWer:OFFset.....	461
[:SOURCE<hw>]:BB:GNSS:SVID<ch>:GLONASS:SIGNAl:L5Band:L3CDma[:STATe].....	464
[:SOURCE<hw>]:BB:GNSS:SVID<ch>:GLONASS:SIMulated:CLOCK:AF<s2us0>.....	490
[:SOURCE<hw>]:BB:GNSS:SVID<ch>:GLONASS:SIMulated:CLOCK:DATE.....	485
[:SOURCE<hw>]:BB:GNSS:SVID<ch>:GLONASS:SIMulated:CLOCK:TGD.....	491
[:SOURCE<hw>]:BB:GNSS:SVID<ch>:GLONASS:SIMulated:CLOCK:TIME.....	485
[:SOURCE<hw>]:BB:GNSS:SVID<ch>:GLONASS:SIMulated:ORBit:DATE.....	485
[:SOURCE<hw>]:BB:GNSS:SVID<ch>:GLONASS:SIMulated:ORBit:TIME.....	485
[:SOURCE<hw>]:BB:GNSS:SVID<ch>:GLONASS:SIMulated:ORBit:XDDN.....	484
[:SOURCE<hw>]:BB:GNSS:SVID<ch>:GLONASS:SIMulated:ORBit:XDN.....	483

[:SOURCE<hw>]:BB:GNSS:SVID<ch>:GLONASS:SIMulated:ORBit:YN.....	483
[:SOURCE<hw>]:BB:GNSS:SVID<ch>:GLONASS:SIMulated:ORBit:YDDN.....	484
[:SOURCE<hw>]:BB:GNSS:SVID<ch>:GLONASS:SIMulated:ORBit:YDN.....	484
[:SOURCE<hw>]:BB:GNSS:SVID<ch>:GLONASS:SIMulated:ORBit:YN.....	483
[:SOURCE<hw>]:BB:GNSS:SVID<ch>:GLONASS:SIMulated:ORBit:ZDDN.....	484
[:SOURCE<hw>]:BB:GNSS:SVID<ch>:GLONASS:SIMulated:ORBit:ZDN.....	484
[:SOURCE<hw>]:BB:GNSS:SVID<ch>:GLONASS:SIMulated:ORBit:ZN.....	483
[:SOURCE<hw>]:BB:GNSS:SVID<ch>:GLONASS:STATE.....	458
[:SOURCE<hw>]:BB:GNSS:SVID<ch>:GLONASS:VISibility:STATE?.....	446
[:SOURCE<hw>]:BB:GNSS:SVID<ch>:GPS:HEALTHy.....	445
[:SOURCE<hw>]:BB:GNSS:SVID<ch>:GPS:MCONtrol:COpy:EXECute.....	478
[:SOURCE<hw>]:BB:GNSS:SVID<ch>:GPS:MCONtrol:COpy:SVID.....	477
[:SOURCE<hw>]:BB:GNSS:SVID<ch>:GPS:MPATH[V<us>:A<gr>]:ECHO<s2us0>:AAZimuth.....	427
[:SOURCE<hw>]:BB:GNSS:SVID<ch>:GPS:MPATH[V<us>:A<gr>]:ECHO<s2us0>:AELEVation.....	427
[:SOURCE<hw>]:BB:GNSS:SVID<ch>:GPS:MPATH[V<us>:A<gr>]:ECHO<s2us0>:CPDRift.....	423
[:SOURCE<hw>]:BB:GNSS:SVID<ch>:GPS:MPATH[V<us>:A<gr>]:ECHO<s2us0>:CPHase.....	425
[:SOURCE<hw>]:BB:GNSS:SVID<ch>:GPS:MPATH[V<us>:A<gr>]:ECHO<s2us0>:DSHift.....	426
[:SOURCE<hw>]:BB:GNSS:SVID<ch>:GPS:MPATH[V<us>:A<gr>]:ECHO<s2us0>:ICPHase.....	423
[:SOURCE<hw>]:BB:GNSS:SVID<ch>:GPS:MPATH[V<us>:A<gr>]:ECHO<s2us0>:POWer.....	424
[:SOURCE<hw>]:BB:GNSS:SVID<ch>:GPS:MPATH[V<us>:A<gr>]:ECHos:COUNT.....	422
[:SOURCE<hw>]:BB:GNSS:SVID<ch>:GPS:MPATH[V<us>:A<gr>]:LOS:AAZimuth?.....	426
[:SOURCE<hw>]:BB:GNSS:SVID<ch>:GPS:MPATH[V<us>:A<gr>]:LOS:AELEVation?.....	427
[:SOURCE<hw>]:BB:GNSS:SVID<ch>:GPS:MPATH[V<us>:A<gr>]:LOS:CPDRift?.....	423
[:SOURCE<hw>]:BB:GNSS:SVID<ch>:GPS:MPATH[V<us>:A<gr>]:LOS:CPHase?.....	425
[:SOURCE<hw>]:BB:GNSS:SVID<ch>:GPS:MPATH[V<us>:A<gr>]:LOS:DSHift?.....	426
[:SOURCE<hw>]:BB:GNSS:SVID<ch>:GPS:MPATH[V<us>:A<gr>]:LOS:ENable.....	421
[:SOURCE<hw>]:BB:GNSS:SVID<ch>:GPS:MPATH[V<us>:A<gr>]:LOS:ICPHase?.....	422
[:SOURCE<hw>]:BB:GNSS:SVID<ch>:GPS:MPATH[V<us>:A<gr>]:LOS:POWer?.....	424
[:SOURCE<hw>]:BB:GNSS:SVID<ch>:GPS:NMESsage:CNAV:CCORrection:ISC:L1CA.....	543
[:SOURCE<hw>]:BB:GNSS:SVID<ch>:GPS:NMESsage:CNAV:CCORrection:ISC:L1CA:UNSCaled.....	543
[:SOURCE<hw>]:BB:GNSS:SVID<ch>:GPS:NMESsage:CNAV:CCORrection:ISC:L2C.....	543
[:SOURCE<hw>]:BB:GNSS:SVID<ch>:GPS:NMESsage:CNAV:CCORrection:ISC:L2C:UNSCaled.....	543
[:SOURCE<hw>]:BB:GNSS:SVID<ch>:GPS:NMESsage:CNAV:CCORrection:ISC:L5I.....	543
[:SOURCE<hw>]:BB:GNSS:SVID<ch>:GPS:NMESsage:CNAV:CCORrection:ISC:L5I:UNSCaled.....	543
[:SOURCE<hw>]:BB:GNSS:SVID<ch>:GPS:NMESsage:CNAV:CCORrection:ISC:L5Q.....	543
[:SOURCE<hw>]:BB:GNSS:SVID<ch>:GPS:NMESsage:CNAV:CCORrection:ISC:L5Q:UNSCaled.....	543
[:SOURCE<hw>]:BB:GNSS:SVID<ch>:GPS:NMESsage:CNAV:CCORrection:AF<s2us0>.....	541
[:SOURCE<hw>]:BB:GNSS:SVID<ch>:GPS:NMESsage:CNAV:CCORrection:AF<s2us0>:UNSCaled.....	541
[:SOURCE<hw>]:BB:GNSS:SVID<ch>:GPS:NMESsage:CNAV:CCORrection:TGD.....	542
[:SOURCE<hw>]:BB:GNSS:SVID<ch>:GPS:NMESsage:CNAV:CCORrection:TGD:UNSCaled.....	542
[:SOURCE<hw>]:BB:GNSS:SVID<ch>:GPS:NMESsage:CNAV:CCORrection:TOC.....	540
[:SOURCE<hw>]:BB:GNSS:SVID<ch>:GPS:NMESsage:CNAV:CCORrection:TOC:UNSCaled.....	540
[:SOURCE<hw>]:BB:GNSS:SVID<ch>:GPS:NMESsage:CNAV:EPHemeris:ADELta.....	531
[:SOURCE<hw>]:BB:GNSS:SVID<ch>:GPS:NMESsage:CNAV:EPHemeris:ADELta:UNSCaled.....	531
[:SOURCE<hw>]:BB:GNSS:SVID<ch>:GPS:NMESsage:CNAV:EPHemeris:ADOT.....	531
[:SOURCE<hw>]:BB:GNSS:SVID<ch>:GPS:NMESsage:CNAV:EPHemeris:ADOT:UNSCaled.....	531
[:SOURCE<hw>]:BB:GNSS:SVID<ch>:GPS:NMESsage:CNAV:EPHemeris:ALERT.....	545
[:SOURCE<hw>]:BB:GNSS:SVID<ch>:GPS:NMESsage:CNAV:EPHemeris:CIC.....	538
[:SOURCE<hw>]:BB:GNSS:SVID<ch>:GPS:NMESsage:CNAV:EPHemeris:CIC:UNSCaled.....	538
[:SOURCE<hw>]:BB:GNSS:SVID<ch>:GPS:NMESsage:CNAV:EPHemeris:CIS.....	539

[SOURce<hw>]:BB:GNSS:SVID<ch>:GPS:NMESsage:CNAV:EPHemeris:CIS:UNSCaled.....	539
[SOURce<hw>]:BB:GNSS:SVID<ch>:GPS:NMESsage:CNAV:EPHemeris:CRC.....	537
[SOURce<hw>]:BB:GNSS:SVID<ch>:GPS:NMESsage:CNAV:EPHemeris:CRC:UNSCaled.....	536
[SOURce<hw>]:BB:GNSS:SVID<ch>:GPS:NMESsage:CNAV:EPHemeris:CRS.....	537
[SOURce<hw>]:BB:GNSS:SVID<ch>:GPS:NMESsage:CNAV:EPHemeris:CRS:UNSCaled.....	537
[SOURce<hw>]:BB:GNSS:SVID<ch>:GPS:NMESsage:CNAV:EPHemeris:CUC.....	535
[SOURce<hw>]:BB:GNSS:SVID<ch>:GPS:NMESsage:CNAV:EPHemeris:CUC:UNSCaled.....	535
[SOURce<hw>]:BB:GNSS:SVID<ch>:GPS:NMESsage:CNAV:EPHemeris:CUS.....	536
[SOURce<hw>]:BB:GNSS:SVID<ch>:GPS:NMESsage:CNAV:EPHemeris:CUS:UNSCaled.....	536
[SOURce<hw>]:BB:GNSS:SVID<ch>:GPS:NMESsage:CNAV:EPHemeris:DNDot.....	531
[SOURce<hw>]:BB:GNSS:SVID<ch>:GPS:NMESsage:CNAV:EPHemeris:DNDot:UNSCaled.....	531
[SOURce<hw>]:BB:GNSS:SVID<ch>:GPS:NMESsage:CNAV:EPHemeris:DODot.....	529
[SOURce<hw>]:BB:GNSS:SVID<ch>:GPS:NMESsage:CNAV:EPHemeris:DODot:UNSCaled.....	529
[SOURce<hw>]:BB:GNSS:SVID<ch>:GPS:NMESsage:CNAV:EPHemeris:ECCentricity.....	524
[SOURce<hw>]:BB:GNSS:SVID<ch>:GPS:NMESsage:CNAV:EPHemeris:ECCentricity:UNSCaled.....	524
[SOURce<hw>]:BB:GNSS:SVID<ch>:GPS:NMESsage:CNAV:EPHemeris:IDOT.....	528
[SOURce<hw>]:BB:GNSS:SVID<ch>:GPS:NMESsage:CNAV:EPHemeris:IDOT:UNSCaled.....	528
[SOURce<hw>]:BB:GNSS:SVID<ch>:GPS:NMESsage:CNAV:EPHemeris:ISFLag.....	546
[SOURce<hw>]:BB:GNSS:SVID<ch>:GPS:NMESsage:CNAV:EPHemeris:IZERo.....	524
[SOURce<hw>]:BB:GNSS:SVID<ch>:GPS:NMESsage:CNAV:EPHemeris:IZERo:UNSCaled.....	524
[SOURce<hw>]:BB:GNSS:SVID<ch>:GPS:NMESsage:CNAV:EPHemeris:L1Health.....	545
[SOURce<hw>]:BB:GNSS:SVID<ch>:GPS:NMESsage:CNAV:EPHemeris:L2CPhasing.....	546
[SOURce<hw>]:BB:GNSS:SVID<ch>:GPS:NMESsage:CNAV:EPHemeris:L2Health.....	545
[SOURce<hw>]:BB:GNSS:SVID<ch>:GPS:NMESsage:CNAV:EPHemeris:L5Health.....	545
[SOURce<hw>]:BB:GNSS:SVID<ch>:GPS:NMESsage:CNAV:EPHemeris:MZERo.....	527
[SOURce<hw>]:BB:GNSS:SVID<ch>:GPS:NMESsage:CNAV:EPHemeris:MZERo:UNSCaled.....	527
[SOURce<hw>]:BB:GNSS:SVID<ch>:GPS:NMESsage:CNAV:EPHemeris:NDELta.....	530
[SOURce<hw>]:BB:GNSS:SVID<ch>:GPS:NMESsage:CNAV:EPHemeris:NDELta:UNSCaled.....	530
[SOURce<hw>]:BB:GNSS:SVID<ch>:GPS:NMESsage:CNAV:EPHemeris:NED0.....	545
[SOURce<hw>]:BB:GNSS:SVID<ch>:GPS:NMESsage:CNAV:EPHemeris:NED1.....	545
[SOURce<hw>]:BB:GNSS:SVID<ch>:GPS:NMESsage:CNAV:EPHemeris:NED2.....	545
[SOURce<hw>]:BB:GNSS:SVID<ch>:GPS:NMESsage:CNAV:EPHemeris:ODOT.....	529
[SOURce<hw>]:BB:GNSS:SVID<ch>:GPS:NMESsage:CNAV:EPHemeris:ODOT:UNSCaled.....	529
[SOURce<hw>]:BB:GNSS:SVID<ch>:GPS:NMESsage:CNAV:EPHemeris:OMEGa.....	526
[SOURce<hw>]:BB:GNSS:SVID<ch>:GPS:NMESsage:CNAV:EPHemeris:OMEGa:UNSCaled.....	526
[SOURce<hw>]:BB:GNSS:SVID<ch>:GPS:NMESsage:CNAV:EPHemeris:OZERo.....	525
[SOURce<hw>]:BB:GNSS:SVID<ch>:GPS:NMESsage:CNAV:EPHemeris:OZERo:UNSCaled.....	525
[SOURce<hw>]:BB:GNSS:SVID<ch>:GPS:NMESsage:CNAV:EPHemeris:SQRA.....	523
[SOURce<hw>]:BB:GNSS:SVID<ch>:GPS:NMESsage:CNAV:EPHemeris:SQRA:UNSCaled.....	523
[SOURce<hw>]:BB:GNSS:SVID<ch>:GPS:NMESsage:CNAV:EPHemeris:TOE.....	522
[SOURce<hw>]:BB:GNSS:SVID<ch>:GPS:NMESsage:CNAV:EPHemeris:TOE:UNSCaled.....	522
[SOURce<hw>]:BB:GNSS:SVID<ch>:GPS:NMESsage:CNAV:EPHemeris:TOP.....	546
[SOURce<hw>]:BB:GNSS:SVID<ch>:GPS:NMESsage:CNAV:EPHemeris:TOP:UNSCaled.....	546
[SOURce<hw>]:BB:GNSS:SVID<ch>:GPS:NMESsage:CNAV:EPHemeris:URA.....	548
[SOURce<hw>]:BB:GNSS:SVID<ch>:GPS:NMESsage:CNAV:EPHemeris:WNOP.....	546
[SOURce<hw>]:BB:GNSS:SVID<ch>:GPS:NMESsage:LNAV:CCORrection:AF<s2us0>.....	542
[SOURce<hw>]:BB:GNSS:SVID<ch>:GPS:NMESsage:LNAV:CCORrection:AF<s2us0>:UNSCaled.....	542
[SOURce<hw>]:BB:GNSS:SVID<ch>:GPS:NMESsage:LNAV:CCORrection:TGD.....	542
[SOURce<hw>]:BB:GNSS:SVID<ch>:GPS:NMESsage:LNAV:CCORrection:TGD:UNSCaled.....	542
[SOURce<hw>]:BB:GNSS:SVID<ch>:GPS:NMESsage:LNAV:CCORrection:TOC.....	541

[:SOURCE<hw>]:BB:GNSS:SVID<ch>:GPS:NMESsage:LNAV:CCORrection:TOC:UNSCaled.....	541
[:SOURCE<hw>]:BB:GNSS:SVID<ch>:GPS:NMESsage:LNAV:EPHemeris:AODO?.....	549
[:SOURCE<hw>]:BB:GNSS:SVID<ch>:GPS:NMESsage:LNAV:EPHemeris:ASF Lag.....	548
[:SOURCE<hw>]:BB:GNSS:SVID<ch>:GPS:NMESsage:LNAV:EPHemeris:CIC.....	538
[:SOURCE<hw>]:BB:GNSS:SVID<ch>:GPS:NMESsage:LNAV:EPHemeris:CIC:UNSCaled.....	538
[:SOURCE<hw>]:BB:GNSS:SVID<ch>:GPS:NMESsage:LNAV:EPHemeris:CIS.....	539
[:SOURCE<hw>]:BB:GNSS:SVID<ch>:GPS:NMESsage:LNAV:EPHemeris:CIS:UNSCaled.....	539
[:SOURCE<hw>]:BB:GNSS:SVID<ch>:GPS:NMESsage:LNAV:EPHemeris:CLTMode.....	548
[:SOURCE<hw>]:BB:GNSS:SVID<ch>:GPS:NMESsage:LNAV:EPHemeris:CRC.....	537
[:SOURCE<hw>]:BB:GNSS:SVID<ch>:GPS:NMESsage:LNAV:EPHemeris:CRC:UNSCaled.....	537
[:SOURCE<hw>]:BB:GNSS:SVID<ch>:GPS:NMESsage:LNAV:EPHemeris:CRS.....	538
[:SOURCE<hw>]:BB:GNSS:SVID<ch>:GPS:NMESsage:LNAV:EPHemeris:CRS:UNSCaled.....	538
[:SOURCE<hw>]:BB:GNSS:SVID<ch>:GPS:NMESsage:LNAV:EPHemeris:CUC.....	535
[:SOURCE<hw>]:BB:GNSS:SVID<ch>:GPS:NMESsage:LNAV:EPHemeris:CUC:UNSCaled.....	535
[:SOURCE<hw>]:BB:GNSS:SVID<ch>:GPS:NMESsage:LNAV:EPHemeris:CUS.....	536
[:SOURCE<hw>]:BB:GNSS:SVID<ch>:GPS:NMESsage:LNAV:EPHemeris:CUS:UNSCaled.....	536
[:SOURCE<hw>]:BB:GNSS:SVID<ch>:GPS:NMESsage:LNAV:EPHemeris:ECCentricity.....	524
[:SOURCE<hw>]:BB:GNSS:SVID<ch>:GPS:NMESsage:LNAV:EPHemeris:ECCentricity:UNSCaled.....	524
[:SOURCE<hw>]:BB:GNSS:SVID<ch>:GPS:NMESsage:LNAV:EPHemeris:FIF Lag.....	549
[:SOURCE<hw>]:BB:GNSS:SVID<ch>:GPS:NMESsage:LNAV:EPHemeris:HEALth.....	547
[:SOURCE<hw>]:BB:GNSS:SVID<ch>:GPS:NMESsage:LNAV:EPHemeris:IDOT.....	528
[:SOURCE<hw>]:BB:GNSS:SVID<ch>:GPS:NMESsage:LNAV:EPHemeris:IDOT:UNSCaled.....	528
[:SOURCE<hw>]:BB:GNSS:SVID<ch>:GPS:NMESsage:LNAV:EPHemeris:IODC.....	540
[:SOURCE<hw>]:BB:GNSS:SVID<ch>:GPS:NMESsage:LNAV:EPHemeris:IODE.....	521
[:SOURCE<hw>]:BB:GNSS:SVID<ch>:GPS:NMESsage:LNAV:EPHemeris:IZERo.....	525
[:SOURCE<hw>]:BB:GNSS:SVID<ch>:GPS:NMESsage:LNAV:EPHemeris:IZERo:UNSCaled.....	525
[:SOURCE<hw>]:BB:GNSS:SVID<ch>:GPS:NMESsage:LNAV:EPHemeris:LTPData.....	548
[:SOURCE<hw>]:BB:GNSS:SVID<ch>:GPS:NMESsage:LNAV:EPHemeris:MZERo.....	527
[:SOURCE<hw>]:BB:GNSS:SVID<ch>:GPS:NMESsage:LNAV:EPHemeris:MZERo:UNSCaled.....	527
[:SOURCE<hw>]:BB:GNSS:SVID<ch>:GPS:NMESsage:LNAV:EPHemeris:NDELta.....	530
[:SOURCE<hw>]:BB:GNSS:SVID<ch>:GPS:NMESsage:LNAV:EPHemeris:NDELta:UNSCaled.....	530
[:SOURCE<hw>]:BB:GNSS:SVID<ch>:GPS:NMESsage:LNAV:EPHemeris:ODOT.....	529
[:SOURCE<hw>]:BB:GNSS:SVID<ch>:GPS:NMESsage:LNAV:EPHemeris:ODOT:UNSCaled.....	529
[:SOURCE<hw>]:BB:GNSS:SVID<ch>:GPS:NMESsage:LNAV:EPHemeris:OMEGa.....	526
[:SOURCE<hw>]:BB:GNSS:SVID<ch>:GPS:NMESsage:LNAV:EPHemeris:OMEGa:UNSCaled.....	526
[:SOURCE<hw>]:BB:GNSS:SVID<ch>:GPS:NMESsage:LNAV:EPHemeris:OZERo.....	525
[:SOURCE<hw>]:BB:GNSS:SVID<ch>:GPS:NMESsage:LNAV:EPHemeris:OZERo:UNSCaled.....	525
[:SOURCE<hw>]:BB:GNSS:SVID<ch>:GPS:NMESsage:LNAV:EPHemeris:SF1Reserved<s2us>?.....	549
[:SOURCE<hw>]:BB:GNSS:SVID<ch>:GPS:NMESsage:LNAV:EPHemeris:SQRA.....	523
[:SOURCE<hw>]:BB:GNSS:SVID<ch>:GPS:NMESsage:LNAV:EPHemeris:SQRA:UNSCaled.....	523
[:SOURCE<hw>]:BB:GNSS:SVID<ch>:GPS:NMESsage:LNAV:EPHemeris:SVConfig.....	548
[:SOURCE<hw>]:BB:GNSS:SVID<ch>:GPS:NMESsage:LNAV:EPHemeris:TOE.....	522
[:SOURCE<hw>]:BB:GNSS:SVID<ch>:GPS:NMESsage:LNAV:EPHemeris:TOE:UNSCaled.....	522
[:SOURCE<hw>]:BB:GNSS:SVID<ch>:GPS:NMESsage:LNAV:EPHemeris:URA.....	548
[:SOURCE<hw>]:BB:GNSS:SVID<ch>:GPS:POWER:COPY:EXECute.....	463
[:SOURCE<hw>]:BB:GNSS:SVID<ch>:GPS:POWER:COPY:SVID.....	462
[:SOURCE<hw>]:BB:GNSS:SVID<ch>:GPS:POWER:OFFSet.....	460
[:SOURCE<hw>]:BB:GNSS:SVID<ch>:GPS:POWER:PLOSS.....	460
[:SOURCE<hw>]:BB:GNSS:SVID<ch>:GPS:PRERrors:COPY:EXECute.....	495
[:SOURCE<hw>]:BB:GNSS:SVID<ch>:GPS:PRERrors:COPY:SVID.....	494

[:SOURCE<hw>]:BB:GNSS:SVID<ch>:GPS:PRERRors:FILE.....	494
[:SOURCE<hw>]:BB:GNSS:SVID<ch>:GPS:PRERRors:MODE.....	493
[:SOURCE<hw>]:BB:GNSS:SVID<ch>:GPS:PRERRors:PROFile:APPend.....	497
[:SOURCE<hw>]:BB:GNSS:SVID<ch>:GPS:PRERRors:PROFile:COUNt?.....	497
[:SOURCE<hw>]:BB:GNSS:SVID<ch>:GPS:PRERRors:PROFile:OFFSet.....	496
[:SOURCE<hw>]:BB:GNSS:SVID<ch>:GPS:PRERRors:PROFile<gr>:DELete.....	499
[:SOURCE<hw>]:BB:GNSS:SVID<ch>:GPS:PRERRors:PROFile<gr>:INSert.....	499
[:SOURCE<hw>]:BB:GNSS:SVID<ch>:GPS:PRERRors:PROFile<gr>:REFerence.....	498
[:SOURCE<hw>]:BB:GNSS:SVID<ch>:GPS:PRERRors:PROFile<gr>:VALue.....	498
[:SOURCE<hw>]:BB:GNSS:SVID<ch>:GPS:PRERRors:VALue.....	496
[:SOURCE<hw>]:BB:GNSS:SVID<ch>:GPS:PRESent.....	459
[:SOURCE<hw>]:BB:GNSS:SVID<ch>:GPS:SDYNameS:ACCel:MAX.....	595
[:SOURCE<hw>]:BB:GNSS:SVID<ch>:GPS:SDYNameS:CAPeriod.....	594
[:SOURCE<hw>]:BB:GNSS:SVID<ch>:GPS:SDYNameS:CONFig.....	593
[:SOURCE<hw>]:BB:GNSS:SVID<ch>:GPS:SDYNameS:CPHase.....	591
[:SOURCE<hw>]:BB:GNSS:SVID<ch>:GPS:SDYNameS:CVPerioD.....	594
[:SOURCE<hw>]:BB:GNSS:SVID<ch>:GPS:SDYNameS:IVELocity.....	593
[:SOURCE<hw>]:BB:GNSS:SVID<ch>:GPS:SDYNameS:JERK:MAX.....	595
[:SOURCE<hw>]:BB:GNSS:SVID<ch>:GPS:SDYNameS:PRANge.....	591
[:SOURCE<hw>]:BB:GNSS:SVID<ch>:GPS:SDYNameS:PROFile.....	590
[:SOURCE<hw>]:BB:GNSS:SVID<ch>:GPS:SDYNameS:RPERioD?.....	596
[:SOURCE<hw>]:BB:GNSS:SVID<ch>:GPS:SDYNameS:TOFFset.....	592
[:SOURCE<hw>]:BB:GNSS:SVID<ch>:GPS:SDYNameS:VELocity.....	592
[:SOURCE<hw>]:BB:GNSS:SVID<ch>:GPS:SIGNal:L1Band:CA:DATA:NMESsage:CONTRol.....	470
[:SOURCE<hw>]:BB:GNSS:SVID<ch>:GPS:SIGNal:L1Band:CA:DATA:NMESsage:DSElect.....	474
[:SOURCE<hw>]:BB:GNSS:SVID<ch>:GPS:SIGNal:L1Band:CA:DATA:NMESsage:PATtern.....	476
[:SOURCE<hw>]:BB:GNSS:SVID<ch>:GPS:SIGNal:L1Band:CA:DATA:NMESsage:TYPE.....	472
[:SOURCE<hw>]:BB:GNSS:SVID<ch>:GPS:SIGNal:L1Band:CA:DATA:NMESsage[:STATe].....	590
[:SOURCE<hw>]:BB:GNSS:SVID<ch>:GPS:SIGNal:L1Band:CA:DATA:PCODE[:STATe].....	467
[:SOURCE<hw>]:BB:GNSS:SVID<ch>:GPS:SIGNal:L1Band:CA:PILOt:PCODE[:STATe].....	467
[:SOURCE<hw>]:BB:GNSS:SVID<ch>:GPS:SIGNal:L1Band:CA:POWer:OFFset.....	462
[:SOURCE<hw>]:BB:GNSS:SVID<ch>:GPS:SIGNal:L1Band:CA[:STATe].....	464
[:SOURCE<hw>]:BB:GNSS:SVID<ch>:GPS:SIGNal:L1Band:L1C:DATA:NMESsage:CONTRol.....	470
[:SOURCE<hw>]:BB:GNSS:SVID<ch>:GPS:SIGNal:L1Band:L1C:DATA:NMESsage:DSElect.....	474
[:SOURCE<hw>]:BB:GNSS:SVID<ch>:GPS:SIGNal:L1Band:L1C:DATA:NMESsage:PATtern.....	476
[:SOURCE<hw>]:BB:GNSS:SVID<ch>:GPS:SIGNal:L1Band:L1C:DATA:NMESsage:TYPE.....	472
[:SOURCE<hw>]:BB:GNSS:SVID<ch>:GPS:SIGNal:L1Band:L1C:DATA:NMESsage[:STATe].....	590
[:SOURCE<hw>]:BB:GNSS:SVID<ch>:GPS:SIGNal:L1Band:L1C:DATA:PCODE[:STATe].....	467
[:SOURCE<hw>]:BB:GNSS:SVID<ch>:GPS:SIGNal:L1Band:L1C:PILOt:PCODE[:STATe].....	467
[:SOURCE<hw>]:BB:GNSS:SVID<ch>:GPS:SIGNal:L1Band:L1C:PILOt:SCODE[:STATe].....	468
[:SOURCE<hw>]:BB:GNSS:SVID<ch>:GPS:SIGNal:L1Band:L1C:POWer:OFFset.....	462
[:SOURCE<hw>]:BB:GNSS:SVID<ch>:GPS:SIGNal:L1Band:L1C[:STATe].....	464
[:SOURCE<hw>]:BB:GNSS:SVID<ch>:GPS:SIGNal:L1Band:M:DATA:NMESsage:CONTRol.....	470
[:SOURCE<hw>]:BB:GNSS:SVID<ch>:GPS:SIGNal:L1Band:M:DATA:NMESsage:DSElect.....	474
[:SOURCE<hw>]:BB:GNSS:SVID<ch>:GPS:SIGNal:L1Band:M:DATA:NMESsage:PATtern.....	476
[:SOURCE<hw>]:BB:GNSS:SVID<ch>:GPS:SIGNal:L1Band:M:DATA:NMESsage:TYPE.....	472
[:SOURCE<hw>]:BB:GNSS:SVID<ch>:GPS:SIGNal:L1Band:M:DATA:NMESsage[:STATe].....	590
[:SOURCE<hw>]:BB:GNSS:SVID<ch>:GPS:SIGNal:L1Band:M:DATA:PCODE[:STATe].....	467
[:SOURCE<hw>]:BB:GNSS:SVID<ch>:GPS:SIGNal:L1Band:M:DATA:SCODE[:STATe].....	468
[:SOURCE<hw>]:BB:GNSS:SVID<ch>:GPS:SIGNal:L1Band:M:POWer:OFFset.....	462

[:SOURce<hw>]:BB:GNSS:SVID<ch>:GPS:SIGNal:L1Band:M[:STATe].....464

[:SOURce<hw>]:BB:GNSS:SVID<ch>:GPS:SIGNal:L1Band:P:DATA:NMESsage:CONTRol..... 470

[:SOURce<hw>]:BB:GNSS:SVID<ch>:GPS:SIGNal:L1Band:P:DATA:NMESsage:DSElect..... 474

[:SOURce<hw>]:BB:GNSS:SVID<ch>:GPS:SIGNal:L1Band:P:DATA:NMESsage:PATtern..... 476

[:SOURce<hw>]:BB:GNSS:SVID<ch>:GPS:SIGNal:L1Band:P:DATA:NMESsage:TYPE..... 472

[:SOURce<hw>]:BB:GNSS:SVID<ch>:GPS:SIGNal:L1Band:P:DATA:NMESsage[:STATe]..... 590

[:SOURce<hw>]:BB:GNSS:SVID<ch>:GPS:SIGNal:L1Band:P:DATA:PCODE[:STATe]..... 467

[:SOURce<hw>]:BB:GNSS:SVID<ch>:GPS:SIGNal:L1Band:P:PILot:PCODE[:STATe]..... 467

[:SOURce<hw>]:BB:GNSS:SVID<ch>:GPS:SIGNal:L1Band:P:POWer:OFFset.....462

[:SOURce<hw>]:BB:GNSS:SVID<ch>:GPS:SIGNal:L1Band:P[:STATe]..... 464

[:SOURce<hw>]:BB:GNSS:SVID<ch>:GPS:SIGNal:L1Band:PY:DATA:NMESsage:CONTRol..... 470

[:SOURce<hw>]:BB:GNSS:SVID<ch>:GPS:SIGNal:L1Band:PY:DATA:NMESsage:DSElect..... 474

[:SOURce<hw>]:BB:GNSS:SVID<ch>:GPS:SIGNal:L1Band:PY:DATA:NMESsage:PATtern.....476

[:SOURce<hw>]:BB:GNSS:SVID<ch>:GPS:SIGNal:L1Band:PY:DATA:NMESsage:TYPE..... 472

[:SOURce<hw>]:BB:GNSS:SVID<ch>:GPS:SIGNal:L1Band:PY:DATA:NMESsage[:STATe]..... 590

[:SOURce<hw>]:BB:GNSS:SVID<ch>:GPS:SIGNal:L1Band:PY:DATA:PCODE[:STATe].....467

[:SOURce<hw>]:BB:GNSS:SVID<ch>:GPS:SIGNal:L1Band:PY:DATA:SCODE[:STATe].....468

[:SOURce<hw>]:BB:GNSS:SVID<ch>:GPS:SIGNal:L1Band:PY:POWer:OFFset.....462

[:SOURce<hw>]:BB:GNSS:SVID<ch>:GPS:SIGNal:L1Band:PY[:STATe]..... 464

[:SOURce<hw>]:BB:GNSS:SVID<ch>:GPS:SIGNal:L2Band:CA:DATA:NMESsage:CONTRol.....470

[:SOURce<hw>]:BB:GNSS:SVID<ch>:GPS:SIGNal:L2Band:CA:DATA:NMESsage:DSElect..... 474

[:SOURce<hw>]:BB:GNSS:SVID<ch>:GPS:SIGNal:L2Band:CA:DATA:NMESsage:PATtern..... 476

[:SOURce<hw>]:BB:GNSS:SVID<ch>:GPS:SIGNal:L2Band:CA:DATA:NMESsage:TYPE..... 472

[:SOURce<hw>]:BB:GNSS:SVID<ch>:GPS:SIGNal:L2Band:CA:DATA:NMESsage[:STATe]..... 590

[:SOURce<hw>]:BB:GNSS:SVID<ch>:GPS:SIGNal:L2Band:CA:DATA:PCODE[:STATe]..... 466

[:SOURce<hw>]:BB:GNSS:SVID<ch>:GPS:SIGNal:L2Band:CA:PILot:PCODE[:STATe]..... 466

[:SOURce<hw>]:BB:GNSS:SVID<ch>:GPS:SIGNal:L2Band:CA:POWer:OFFset..... 462

[:SOURce<hw>]:BB:GNSS:SVID<ch>:GPS:SIGNal:L2Band:CA[:STATe].....464

[:SOURce<hw>]:BB:GNSS:SVID<ch>:GPS:SIGNal:L2Band:L2C:DATA:NMESsage:CONTRol..... 470

[:SOURce<hw>]:BB:GNSS:SVID<ch>:GPS:SIGNal:L2Band:L2C:DATA:NMESsage:DSElect..... 474

[:SOURce<hw>]:BB:GNSS:SVID<ch>:GPS:SIGNal:L2Band:L2C:DATA:NMESsage:PATtern.....476

[:SOURce<hw>]:BB:GNSS:SVID<ch>:GPS:SIGNal:L2Band:L2C:DATA:NMESsage:TYPE.....472

[:SOURce<hw>]:BB:GNSS:SVID<ch>:GPS:SIGNal:L2Band:L2C:DATA:NMESsage[:STATe]..... 590

[:SOURce<hw>]:BB:GNSS:SVID<ch>:GPS:SIGNal:L2Band:L2C:DATA:PCODE[:STATe].....466

[:SOURce<hw>]:BB:GNSS:SVID<ch>:GPS:SIGNal:L2Band:L2C:PILot:PCODE[:STATe]..... 466

[:SOURce<hw>]:BB:GNSS:SVID<ch>:GPS:SIGNal:L2Band:L2C:POWer:OFFset.....462

[:SOURce<hw>]:BB:GNSS:SVID<ch>:GPS:SIGNal:L2Band:L2C[:STATe]..... 464

[:SOURce<hw>]:BB:GNSS:SVID<ch>:GPS:SIGNal:L2Band:M:DATA:NMESsage:CONTRol.....470

[:SOURce<hw>]:BB:GNSS:SVID<ch>:GPS:SIGNal:L2Band:M:DATA:NMESsage:DSElect..... 474

[:SOURce<hw>]:BB:GNSS:SVID<ch>:GPS:SIGNal:L2Band:M:DATA:NMESsage:PATtern..... 476

[:SOURce<hw>]:BB:GNSS:SVID<ch>:GPS:SIGNal:L2Band:M:DATA:NMESsage:TYPE..... 472

[:SOURce<hw>]:BB:GNSS:SVID<ch>:GPS:SIGNal:L2Band:M:DATA:NMESsage[:STATe]..... 590

[:SOURce<hw>]:BB:GNSS:SVID<ch>:GPS:SIGNal:L2Band:M:DATA:PCODE[:STATe]..... 467

[:SOURce<hw>]:BB:GNSS:SVID<ch>:GPS:SIGNal:L2Band:M:DATA:SCODE[:STATe]..... 468

[:SOURce<hw>]:BB:GNSS:SVID<ch>:GPS:SIGNal:L2Band:M:POWer:OFFset..... 462

[:SOURce<hw>]:BB:GNSS:SVID<ch>:GPS:SIGNal:L2Band:M[:STATe].....464

[:SOURce<hw>]:BB:GNSS:SVID<ch>:GPS:SIGNal:L2Band:P:DATA:NMESsage:CONTRol..... 470

[:SOURce<hw>]:BB:GNSS:SVID<ch>:GPS:SIGNal:L2Band:P:DATA:NMESsage:DSElect..... 474

[:SOURce<hw>]:BB:GNSS:SVID<ch>:GPS:SIGNal:L2Band:P:DATA:NMESsage:PATtern.....476

[:SOURce<hw>]:BB:GNSS:SVID<ch>:GPS:SIGNal:L2Band:P:DATA:NMESsage:TYPE..... 472

[SOURce<hw>]:BB:GNSS:SVID<ch>:GPS:SIGNaL:L2Band:P:DATA:NMESsage[:STATe].....	590
[SOURce<hw>]:BB:GNSS:SVID<ch>:GPS:SIGNaL:L2Band:P:DATA:PCODE[:STATe].....	467
[SOURce<hw>]:BB:GNSS:SVID<ch>:GPS:SIGNaL:L2Band:P:PILot:PCODE[:STATe].....	467
[SOURce<hw>]:BB:GNSS:SVID<ch>:GPS:SIGNaL:L2Band:P:POWer:OFFset.....	462
[SOURce<hw>]:BB:GNSS:SVID<ch>:GPS:SIGNaL:L2Band:P[:STATe].....	464
[SOURce<hw>]:BB:GNSS:SVID<ch>:GPS:SIGNaL:L2Band:PY:DATA:NMESsage:CONTRol.....	470
[SOURce<hw>]:BB:GNSS:SVID<ch>:GPS:SIGNaL:L2Band:PY:DATA:NMESsage:DSElect.....	474
[SOURce<hw>]:BB:GNSS:SVID<ch>:GPS:SIGNaL:L2Band:PY:DATA:NMESsage:PATTern.....	476
[SOURce<hw>]:BB:GNSS:SVID<ch>:GPS:SIGNaL:L2Band:PY:DATA:NMESsage:TYPE.....	472
[SOURce<hw>]:BB:GNSS:SVID<ch>:GPS:SIGNaL:L2Band:PY:DATA:NMESsage[:STATe].....	590
[SOURce<hw>]:BB:GNSS:SVID<ch>:GPS:SIGNaL:L2Band:PY:DATA:PCODE[:STATe].....	467
[SOURce<hw>]:BB:GNSS:SVID<ch>:GPS:SIGNaL:L2Band:PY:DATA:SCODE[:STATe].....	468
[SOURce<hw>]:BB:GNSS:SVID<ch>:GPS:SIGNaL:L2Band:PY:POWer:OFFset.....	462
[SOURce<hw>]:BB:GNSS:SVID<ch>:GPS:SIGNaL:L2Band:PY[:STATe].....	464
[SOURce<hw>]:BB:GNSS:SVID<ch>:GPS:SIGNaL:L5Band:L5S:DATA:NMESsage:CONTRol.....	470
[SOURce<hw>]:BB:GNSS:SVID<ch>:GPS:SIGNaL:L5Band:L5S:DATA:NMESsage:DSElect.....	474
[SOURce<hw>]:BB:GNSS:SVID<ch>:GPS:SIGNaL:L5Band:L5S:DATA:NMESsage:PATTern.....	476
[SOURce<hw>]:BB:GNSS:SVID<ch>:GPS:SIGNaL:L5Band:L5S:DATA:NMESsage:TYPE.....	472
[SOURce<hw>]:BB:GNSS:SVID<ch>:GPS:SIGNaL:L5Band:L5S:DATA:NMESsage[:STATe].....	590
[SOURce<hw>]:BB:GNSS:SVID<ch>:GPS:SIGNaL:L5Band:L5S:DATA:PCODE[:STATe].....	466
[SOURce<hw>]:BB:GNSS:SVID<ch>:GPS:SIGNaL:L5Band:L5S:DATA:SCODE[:STATe].....	468
[SOURce<hw>]:BB:GNSS:SVID<ch>:GPS:SIGNaL:L5Band:L5S:PILot:PCODE[:STATe].....	466
[SOURce<hw>]:BB:GNSS:SVID<ch>:GPS:SIGNaL:L5Band:L5S:PILot:SCODE[:STATe].....	468
[SOURce<hw>]:BB:GNSS:SVID<ch>:GPS:SIGNaL:L5Band:L5S:POWer:OFFset.....	462
[SOURce<hw>]:BB:GNSS:SVID<ch>:GPS:SIGNaL:L5Band:L5S[:STATe].....	464
[SOURce<hw>]:BB:GNSS:SVID<ch>:GPS:SIMulated:CLOCK:AF<s2us0>.....	490
[SOURce<hw>]:BB:GNSS:SVID<ch>:GPS:SIMulated:CLOCK:TGD.....	491
[SOURce<hw>]:BB:GNSS:SVID<ch>:GPS:SIMulated:CLOCK:TOC.....	490
[SOURce<hw>]:BB:GNSS:SVID<ch>:GPS:SIMulated:CLOCK:WNOC.....	490
[SOURce<hw>]:BB:GNSS:SVID<ch>:GPS:SIMulated:ORBit:CIC.....	489
[SOURce<hw>]:BB:GNSS:SVID<ch>:GPS:SIMulated:ORBit:CIS.....	490
[SOURce<hw>]:BB:GNSS:SVID<ch>:GPS:SIMulated:ORBit:CRC.....	489
[SOURce<hw>]:BB:GNSS:SVID<ch>:GPS:SIMulated:ORBit:CRS.....	489
[SOURce<hw>]:BB:GNSS:SVID<ch>:GPS:SIMulated:ORBit:CUC.....	488
[SOURce<hw>]:BB:GNSS:SVID<ch>:GPS:SIMulated:ORBit:CUS.....	488
[SOURce<hw>]:BB:GNSS:SVID<ch>:GPS:SIMulated:ORBit:ECCentricity.....	486
[SOURce<hw>]:BB:GNSS:SVID<ch>:GPS:SIMulated:ORBit:IDOT.....	487
[SOURce<hw>]:BB:GNSS:SVID<ch>:GPS:SIMulated:ORBit:IZERo.....	486
[SOURce<hw>]:BB:GNSS:SVID<ch>:GPS:SIMulated:ORBit:MZERo.....	487
[SOURce<hw>]:BB:GNSS:SVID<ch>:GPS:SIMulated:ORBit:NDELta.....	488
[SOURce<hw>]:BB:GNSS:SVID<ch>:GPS:SIMulated:ORBit:ODOT.....	488
[SOURce<hw>]:BB:GNSS:SVID<ch>:GPS:SIMulated:ORBit:OMEGa.....	487
[SOURce<hw>]:BB:GNSS:SVID<ch>:GPS:SIMulated:ORBit:OZERo.....	487
[SOURce<hw>]:BB:GNSS:SVID<ch>:GPS:SIMulated:ORBit:SQRA.....	486
[SOURce<hw>]:BB:GNSS:SVID<ch>:GPS:SIMulated:ORBit:TOE.....	484
[SOURce<hw>]:BB:GNSS:SVID<ch>:GPS:SIMulated:ORBit:WNOE.....	484
[SOURce<hw>]:BB:GNSS:SVID<ch>:GPS:STATe.....	459
[SOURce<hw>]:BB:GNSS:SVID<ch>:GPS:VISibility:STATe?.....	446
[SOURce<hw>]:BB:GNSS:SVID<ch>:NAVic:HEALTHy.....	444
[SOURce<hw>]:BB:GNSS:SVID<ch>:NAVic:MCONTRol:COPY:EXECute.....	478

[:SOURCE<hw>]:BB:GNSS:SVID<ch>:NAVic:MCONtrol:CoPY:SVID.....	477
[:SOURCE<hw>]:BB:GNSS:SVID<ch>:NAVic:MPATH[V<us>:A<gr>]:ECHO<s2us0>:AAZimuth.....	426
[:SOURCE<hw>]:BB:GNSS:SVID<ch>:NAVic:MPATH[V<us>:A<gr>]:ECHO<s2us0>:AELEVation.....	427
[:SOURCE<hw>]:BB:GNSS:SVID<ch>:NAVic:MPATH[V<us>:A<gr>]:ECHO<s2us0>:CPDRift.....	423
[:SOURCE<hw>]:BB:GNSS:SVID<ch>:NAVic:MPATH[V<us>:A<gr>]:ECHO<s2us0>:CPHase.....	425
[:SOURCE<hw>]:BB:GNSS:SVID<ch>:NAVic:MPATH[V<us>:A<gr>]:ECHO<s2us0>:DSHift.....	426
[:SOURCE<hw>]:BB:GNSS:SVID<ch>:NAVic:MPATH[V<us>:A<gr>]:ECHO<s2us0>:ICPHase.....	422
[:SOURCE<hw>]:BB:GNSS:SVID<ch>:NAVic:MPATH[V<us>:A<gr>]:ECHO<s2us0>:POWer.....	424
[:SOURCE<hw>]:BB:GNSS:SVID<ch>:NAVic:MPATH[V<us>:A<gr>]:ECHos:CoUNt.....	422
[:SOURCE<hw>]:BB:GNSS:SVID<ch>:NAVic:MPATH[V<us>:A<gr>]:LOS:AAZimuth?.....	426
[:SOURCE<hw>]:BB:GNSS:SVID<ch>:NAVic:MPATH[V<us>:A<gr>]:LOS:AELEVation?.....	427
[:SOURCE<hw>]:BB:GNSS:SVID<ch>:NAVic:MPATH[V<us>:A<gr>]:LOS:CPDRift?.....	423
[:SOURCE<hw>]:BB:GNSS:SVID<ch>:NAVic:MPATH[V<us>:A<gr>]:LOS:CPHase?.....	425
[:SOURCE<hw>]:BB:GNSS:SVID<ch>:NAVic:MPATH[V<us>:A<gr>]:LOS:DSHift?.....	426
[:SOURCE<hw>]:BB:GNSS:SVID<ch>:NAVic:MPATH[V<us>:A<gr>]:LOS:ENABLE.....	421
[:SOURCE<hw>]:BB:GNSS:SVID<ch>:NAVic:MPATH[V<us>:A<gr>]:LOS:ICPHase?.....	422
[:SOURCE<hw>]:BB:GNSS:SVID<ch>:NAVic:MPATH[V<us>:A<gr>]:LOS:POWer?.....	424
[:SOURCE<hw>]:BB:GNSS:SVID<ch>:NAVic:NMESsage:NAV:CCORrection:AF<s2us0>.....	541
[:SOURCE<hw>]:BB:GNSS:SVID<ch>:NAVic:NMESsage:NAV:CCORrection:AF<s2us0>:UNSCaled.....	541
[:SOURCE<hw>]:BB:GNSS:SVID<ch>:NAVic:NMESsage:NAV:CCORrection:TGD.....	542
[:SOURCE<hw>]:BB:GNSS:SVID<ch>:NAVic:NMESsage:NAV:CCORrection:TGD:UNSCaled.....	542
[:SOURCE<hw>]:BB:GNSS:SVID<ch>:NAVic:NMESsage:NAV:CCORrection:TOC.....	540
[:SOURCE<hw>]:BB:GNSS:SVID<ch>:NAVic:NMESsage:NAV:CCORrection:TOC:UNSCaled.....	540
[:SOURCE<hw>]:BB:GNSS:SVID<ch>:NAVic:NMESsage:NAV:EPHemeris:CIC.....	538
[:SOURCE<hw>]:BB:GNSS:SVID<ch>:NAVic:NMESsage:NAV:EPHemeris:CIC:UNSCaled.....	538
[:SOURCE<hw>]:BB:GNSS:SVID<ch>:NAVic:NMESsage:NAV:EPHemeris:CIS.....	539
[:SOURCE<hw>]:BB:GNSS:SVID<ch>:NAVic:NMESsage:NAV:EPHemeris:CIS:UNSCaled.....	539
[:SOURCE<hw>]:BB:GNSS:SVID<ch>:NAVic:NMESsage:NAV:EPHemeris:CRc.....	536
[:SOURCE<hw>]:BB:GNSS:SVID<ch>:NAVic:NMESsage:NAV:EPHemeris:CRc:UNSCaled.....	536
[:SOURCE<hw>]:BB:GNSS:SVID<ch>:NAVic:NMESsage:NAV:EPHemeris:CRS.....	537
[:SOURCE<hw>]:BB:GNSS:SVID<ch>:NAVic:NMESsage:NAV:EPHemeris:CRS:UNSCaled.....	537
[:SOURCE<hw>]:BB:GNSS:SVID<ch>:NAVic:NMESsage:NAV:EPHemeris:CUC.....	534
[:SOURCE<hw>]:BB:GNSS:SVID<ch>:NAVic:NMESsage:NAV:EPHemeris:CUC:UNSCaled.....	534
[:SOURCE<hw>]:BB:GNSS:SVID<ch>:NAVic:NMESsage:NAV:EPHemeris:CUS.....	535
[:SOURCE<hw>]:BB:GNSS:SVID<ch>:NAVic:NMESsage:NAV:EPHemeris:CUS:UNSCaled.....	535
[:SOURCE<hw>]:BB:GNSS:SVID<ch>:NAVic:NMESsage:NAV:EPHemeris:ECcEntricity.....	523
[:SOURCE<hw>]:BB:GNSS:SVID<ch>:NAVic:NMESsage:NAV:EPHemeris:ECcEntricity:UNSCaled.....	523
[:SOURCE<hw>]:BB:GNSS:SVID<ch>:NAVic:NMESsage:NAV:EPHemeris:IDOT.....	527
[:SOURCE<hw>]:BB:GNSS:SVID<ch>:NAVic:NMESsage:NAV:EPHemeris:IDOT:UNSCaled.....	527
[:SOURCE<hw>]:BB:GNSS:SVID<ch>:NAVic:NMESsage:NAV:EPHemeris:IODE.....	521
[:SOURCE<hw>]:BB:GNSS:SVID<ch>:NAVic:NMESsage:NAV:EPHemeris:IZERo.....	524
[:SOURCE<hw>]:BB:GNSS:SVID<ch>:NAVic:NMESsage:NAV:EPHemeris:IZERo:UNSCaled.....	524
[:SOURCE<hw>]:BB:GNSS:SVID<ch>:NAVic:NMESsage:NAV:EPHemeris:L5Health.....	547
[:SOURCE<hw>]:BB:GNSS:SVID<ch>:NAVic:NMESsage:NAV:EPHemeris:MZERo.....	527
[:SOURCE<hw>]:BB:GNSS:SVID<ch>:NAVic:NMESsage:NAV:EPHemeris:MZERo:UNSCaled.....	527
[:SOURCE<hw>]:BB:GNSS:SVID<ch>:NAVic:NMESsage:NAV:EPHemeris:NDELta.....	529
[:SOURCE<hw>]:BB:GNSS:SVID<ch>:NAVic:NMESsage:NAV:EPHemeris:NDELta:UNSCaled.....	529
[:SOURCE<hw>]:BB:GNSS:SVID<ch>:NAVic:NMESsage:NAV:EPHemeris:ODOT.....	528
[:SOURCE<hw>]:BB:GNSS:SVID<ch>:NAVic:NMESsage:NAV:EPHemeris:ODOT:UNSCaled.....	528
[:SOURCE<hw>]:BB:GNSS:SVID<ch>:NAVic:NMESsage:NAV:EPHemeris:OMEGa.....	526

[:SOURCE<hw>]:BB:GNSS:SVID<ch>:NAVic:NMESsage:NAV:EPHemeris:OMEGa:UNSCaled.....	526
[:SOURCE<hw>]:BB:GNSS:SVID<ch>:NAVic:NMESsage:NAV:EPHemeris:OZERo.....	525
[:SOURCE<hw>]:BB:GNSS:SVID<ch>:NAVic:NMESsage:NAV:EPHemeris:OZERo:UNSCaled.....	525
[:SOURCE<hw>]:BB:GNSS:SVID<ch>:NAVic:NMESsage:NAV:EPHemeris:SHEalth.....	547
[:SOURCE<hw>]:BB:GNSS:SVID<ch>:NAVic:NMESsage:NAV:EPHemeris:SQRA.....	522
[:SOURCE<hw>]:BB:GNSS:SVID<ch>:NAVic:NMESsage:NAV:EPHemeris:SQRA:UNSCaled.....	522
[:SOURCE<hw>]:BB:GNSS:SVID<ch>:NAVic:NMESsage:NAV:EPHemeris:TOE.....	521
[:SOURCE<hw>]:BB:GNSS:SVID<ch>:NAVic:NMESsage:NAV:EPHemeris:TOE:UNSCaled.....	521
[:SOURCE<hw>]:BB:GNSS:SVID<ch>:NAVic:NMESsage:NAV:EPHemeris:URA.....	547
[:SOURCE<hw>]:BB:GNSS:SVID<ch>:NAVic:POWER:COPY:EXECute.....	463
[:SOURCE<hw>]:BB:GNSS:SVID<ch>:NAVic:POWER:COPY:SVID.....	462
[:SOURCE<hw>]:BB:GNSS:SVID<ch>:NAVic:POWER:OFFSet.....	460
[:SOURCE<hw>]:BB:GNSS:SVID<ch>:NAVic:POWER:PLOSs.....	460
[:SOURCE<hw>]:BB:GNSS:SVID<ch>:NAVic:PREErrors:COPY:EXECute.....	495
[:SOURCE<hw>]:BB:GNSS:SVID<ch>:NAVic:PREErrors:COPY:SVID.....	494
[:SOURCE<hw>]:BB:GNSS:SVID<ch>:NAVic:PREErrors:FILE.....	494
[:SOURCE<hw>]:BB:GNSS:SVID<ch>:NAVic:PREErrors:MODE.....	493
[:SOURCE<hw>]:BB:GNSS:SVID<ch>:NAVic:PREErrors:PROFile:APPend.....	497
[:SOURCE<hw>]:BB:GNSS:SVID<ch>:NAVic:PREErrors:PROFile:COUNT?.....	496
[:SOURCE<hw>]:BB:GNSS:SVID<ch>:NAVic:PREErrors:PROFile:OFFSet.....	496
[:SOURCE<hw>]:BB:GNSS:SVID<ch>:NAVic:PREErrors:PROFile<gr>:DELeTe.....	499
[:SOURCE<hw>]:BB:GNSS:SVID<ch>:NAVic:PREErrors:PROFile<gr>:INSert.....	499
[:SOURCE<hw>]:BB:GNSS:SVID<ch>:NAVic:PREErrors:PROFile<gr>:REFerence.....	497
[:SOURCE<hw>]:BB:GNSS:SVID<ch>:NAVic:PREErrors:PROFile<gr>:VALue.....	498
[:SOURCE<hw>]:BB:GNSS:SVID<ch>:NAVic:PREErrors:VALue.....	495
[:SOURCE<hw>]:BB:GNSS:SVID<ch>:NAVic:PRESent.....	459
[:SOURCE<hw>]:BB:GNSS:SVID<ch>:NAVic:SDYNamics:ACCel:MAX.....	595
[:SOURCE<hw>]:BB:GNSS:SVID<ch>:NAVic:SDYNamics:CAPeriod.....	594
[:SOURCE<hw>]:BB:GNSS:SVID<ch>:NAVic:SDYNamics:CONFig.....	593
[:SOURCE<hw>]:BB:GNSS:SVID<ch>:NAVic:SDYNamics:CPHase.....	591
[:SOURCE<hw>]:BB:GNSS:SVID<ch>:NAVic:SDYNamics:CVPeriod.....	594
[:SOURCE<hw>]:BB:GNSS:SVID<ch>:NAVic:SDYNamics:IVELocity.....	592
[:SOURCE<hw>]:BB:GNSS:SVID<ch>:NAVic:SDYNamics:JERK:MAX.....	595
[:SOURCE<hw>]:BB:GNSS:SVID<ch>:NAVic:SDYNamics:PRANge.....	591
[:SOURCE<hw>]:BB:GNSS:SVID<ch>:NAVic:SDYNamics:PROFile.....	590
[:SOURCE<hw>]:BB:GNSS:SVID<ch>:NAVic:SDYNamics:RPERiod?.....	596
[:SOURCE<hw>]:BB:GNSS:SVID<ch>:NAVic:SDYNamics:TOFFset.....	592
[:SOURCE<hw>]:BB:GNSS:SVID<ch>:NAVic:SDYNamics:VELocity.....	592
[:SOURCE<hw>]:BB:GNSS:SVID<ch>:NAVic:SIGNal:L5Band:SPS:DATA:NMESsage:CONTRol.....	469
[:SOURCE<hw>]:BB:GNSS:SVID<ch>:NAVic:SIGNal:L5Band:SPS:DATA:NMESsage:DSElect.....	473
[:SOURCE<hw>]:BB:GNSS:SVID<ch>:NAVic:SIGNal:L5Band:SPS:DATA:NMESsage:PATtern.....	475
[:SOURCE<hw>]:BB:GNSS:SVID<ch>:NAVic:SIGNal:L5Band:SPS:DATA:NMESsage:TYPE.....	471
[:SOURCE<hw>]:BB:GNSS:SVID<ch>:NAVic:SIGNal:L5Band:SPS:DATA:NMESsage[:STATe].....	589
[:SOURCE<hw>]:BB:GNSS:SVID<ch>:NAVic:SIGNal:L5Band:SPS:DATA:PCODE[:STATe].....	465
[:SOURCE<hw>]:BB:GNSS:SVID<ch>:NAVic:SIGNal:L5Band:SPS:POWER:OFFset.....	461
[:SOURCE<hw>]:BB:GNSS:SVID<ch>:NAVic:SIGNal:L5Band:SPS[:STATe].....	463
[:SOURCE<hw>]:BB:GNSS:SVID<ch>:NAVic:SIMulated:CLOCK:AF<s2us0>.....	490
[:SOURCE<hw>]:BB:GNSS:SVID<ch>:NAVic:SIMulated:CLOCK:TGD.....	491
[:SOURCE<hw>]:BB:GNSS:SVID<ch>:NAVic:SIMulated:CLOCK:TOC.....	490
[:SOURCE<hw>]:BB:GNSS:SVID<ch>:NAVic:SIMulated:CLOCK:WNOC.....	490

[SOURce<hw>]:BB:GNSS:SVID<ch>:NAVic:SIMulated:ORBit:CIC.....	489
[SOURce<hw>]:BB:GNSS:SVID<ch>:NAVic:SIMulated:ORBit:CIS.....	489
[SOURce<hw>]:BB:GNSS:SVID<ch>:NAVic:SIMulated:ORBit:CRC.....	489
[SOURce<hw>]:BB:GNSS:SVID<ch>:NAVic:SIMulated:ORBit:CRS.....	489
[SOURce<hw>]:BB:GNSS:SVID<ch>:NAVic:SIMulated:ORBit:CUC.....	488
[SOURce<hw>]:BB:GNSS:SVID<ch>:NAVic:SIMulated:ORBit:CUS.....	488
[SOURce<hw>]:BB:GNSS:SVID<ch>:NAVic:SIMulated:ORBit:ECCentricity.....	486
[SOURce<hw>]:BB:GNSS:SVID<ch>:NAVic:SIMulated:ORBit:IDOT.....	487
[SOURce<hw>]:BB:GNSS:SVID<ch>:NAVic:SIMulated:ORBit:IZERo.....	486
[SOURce<hw>]:BB:GNSS:SVID<ch>:NAVic:SIMulated:ORBit:MZERo.....	487
[SOURce<hw>]:BB:GNSS:SVID<ch>:NAVic:SIMulated:ORBit:NDELta.....	488
[SOURce<hw>]:BB:GNSS:SVID<ch>:NAVic:SIMulated:ORBit:ODOT.....	488
[SOURce<hw>]:BB:GNSS:SVID<ch>:NAVic:SIMulated:ORBit:OMEGa.....	487
[SOURce<hw>]:BB:GNSS:SVID<ch>:NAVic:SIMulated:ORBit:OZERo.....	486
[SOURce<hw>]:BB:GNSS:SVID<ch>:NAVic:SIMulated:ORBit:SQRA.....	485
[SOURce<hw>]:BB:GNSS:SVID<ch>:NAVic:SIMulated:ORBit:TOE.....	484
[SOURce<hw>]:BB:GNSS:SVID<ch>:NAVic:SIMulated:ORBit:WNOE.....	484
[SOURce<hw>]:BB:GNSS:SVID<ch>:NAVic:STATe.....	458
[SOURce<hw>]:BB:GNSS:SVID<ch>:NAVic:VISibility:STATe?.....	446
[SOURce<hw>]:BB:GNSS:SVID<ch>:QZSS:HEALthy.....	444
[SOURce<hw>]:BB:GNSS:SVID<ch>:QZSS:MCONtrol:CoPY:EXECute.....	478
[SOURce<hw>]:BB:GNSS:SVID<ch>:QZSS:MCONtrol:CoPY:SVID.....	477
[SOURce<hw>]:BB:GNSS:SVID<ch>:QZSS:MPATH[V<us>:A<gr>]:ECHO<s2us0>:AAZimuth.....	426
[SOURce<hw>]:BB:GNSS:SVID<ch>:QZSS:MPATH[V<us>:A<gr>]:ECHO<s2us0>:AELEVation.....	427
[SOURce<hw>]:BB:GNSS:SVID<ch>:QZSS:MPATH[V<us>:A<gr>]:ECHO<s2us0>:CPDRift.....	423
[SOURce<hw>]:BB:GNSS:SVID<ch>:QZSS:MPATH[V<us>:A<gr>]:ECHO<s2us0>:CPHase.....	425
[SOURce<hw>]:BB:GNSS:SVID<ch>:QZSS:MPATH[V<us>:A<gr>]:ECHO<s2us0>:DSHift.....	426
[SOURce<hw>]:BB:GNSS:SVID<ch>:QZSS:MPATH[V<us>:A<gr>]:ECHO<s2us0>:ICPHase.....	422
[SOURce<hw>]:BB:GNSS:SVID<ch>:QZSS:MPATH[V<us>:A<gr>]:ECHO<s2us0>:POWER.....	424
[SOURce<hw>]:BB:GNSS:SVID<ch>:QZSS:MPATH[V<us>:A<gr>]:ECHos:CoUNT.....	422
[SOURce<hw>]:BB:GNSS:SVID<ch>:QZSS:MPATH[V<us>:A<gr>]:LOS:AAZimuth?.....	426
[SOURce<hw>]:BB:GNSS:SVID<ch>:QZSS:MPATH[V<us>:A<gr>]:LOS:AELEVation?.....	427
[SOURce<hw>]:BB:GNSS:SVID<ch>:QZSS:MPATH[V<us>:A<gr>]:LOS:CPDRift?.....	423
[SOURce<hw>]:BB:GNSS:SVID<ch>:QZSS:MPATH[V<us>:A<gr>]:LOS:CPHase?.....	425
[SOURce<hw>]:BB:GNSS:SVID<ch>:QZSS:MPATH[V<us>:A<gr>]:LOS:DSHift?.....	426
[SOURce<hw>]:BB:GNSS:SVID<ch>:QZSS:MPATH[V<us>:A<gr>]:LOS:ENABLE.....	421
[SOURce<hw>]:BB:GNSS:SVID<ch>:QZSS:MPATH[V<us>:A<gr>]:LOS:ICPHase?.....	422
[SOURce<hw>]:BB:GNSS:SVID<ch>:QZSS:MPATH[V<us>:A<gr>]:LOS:POWER?.....	424
[SOURce<hw>]:BB:GNSS:SVID<ch>:QZSS:NMESsage:CNAV:CCORrection:ISC:L1CA.....	543
[SOURce<hw>]:BB:GNSS:SVID<ch>:QZSS:NMESsage:CNAV:CCORrection:ISC:L1CA:UNSCaled.....	543
[SOURce<hw>]:BB:GNSS:SVID<ch>:QZSS:NMESsage:CNAV:CCORrection:ISC:L2C.....	543
[SOURce<hw>]:BB:GNSS:SVID<ch>:QZSS:NMESsage:CNAV:CCORrection:ISC:L2C:UNSCaled.....	543
[SOURce<hw>]:BB:GNSS:SVID<ch>:QZSS:NMESsage:CNAV:CCORrection:ISC:L5I.....	543
[SOURce<hw>]:BB:GNSS:SVID<ch>:QZSS:NMESsage:CNAV:CCORrection:ISC:L5I:UNSCaled.....	543
[SOURce<hw>]:BB:GNSS:SVID<ch>:QZSS:NMESsage:CNAV:CCORrection:ISC:L5Q.....	543
[SOURce<hw>]:BB:GNSS:SVID<ch>:QZSS:NMESsage:CNAV:CCORrection:ISC:L5Q:UNSCaled.....	543
[SOURce<hw>]:BB:GNSS:SVID<ch>:QZSS:NMESsage:CNAV:CCORrection:AF<s2us0>.....	541
[SOURce<hw>]:BB:GNSS:SVID<ch>:QZSS:NMESsage:CNAV:CCORrection:AF<s2us0>:UNSCaled.....	541
[SOURce<hw>]:BB:GNSS:SVID<ch>:QZSS:NMESsage:CNAV:CCORrection:TGD.....	542
[SOURce<hw>]:BB:GNSS:SVID<ch>:QZSS:NMESsage:CNAV:CCORrection:TGD:UNSCaled.....	542

[:SOURCE<hw>]:BB:GNSS:SVID<ch>:QZSS:NMESsage:CNAV:CCORrection:TOC.....	540
[:SOURCE<hw>]:BB:GNSS:SVID<ch>:QZSS:NMESsage:CNAV:CCORrection:TOC:UNSCaled.....	540
[:SOURCE<hw>]:BB:GNSS:SVID<ch>:QZSS:NMESsage:CNAV:EPHemeris:ADELta.....	531
[:SOURCE<hw>]:BB:GNSS:SVID<ch>:QZSS:NMESsage:CNAV:EPHemeris:ADELta:UNSCaled.....	531
[:SOURCE<hw>]:BB:GNSS:SVID<ch>:QZSS:NMESsage:CNAV:EPHemeris:ADOT.....	531
[:SOURCE<hw>]:BB:GNSS:SVID<ch>:QZSS:NMESsage:CNAV:EPHemeris:ADOT:UNSCaled.....	531
[:SOURCE<hw>]:BB:GNSS:SVID<ch>:QZSS:NMESsage:CNAV:EPHemeris:ALERT.....	545
[:SOURCE<hw>]:BB:GNSS:SVID<ch>:QZSS:NMESsage:CNAV:EPHemeris:CIC.....	538
[:SOURCE<hw>]:BB:GNSS:SVID<ch>:QZSS:NMESsage:CNAV:EPHemeris:CIC:UNSCaled.....	538
[:SOURCE<hw>]:BB:GNSS:SVID<ch>:QZSS:NMESsage:CNAV:EPHemeris:CIS.....	539
[:SOURCE<hw>]:BB:GNSS:SVID<ch>:QZSS:NMESsage:CNAV:EPHemeris:CIS:UNSCaled.....	539
[:SOURCE<hw>]:BB:GNSS:SVID<ch>:QZSS:NMESsage:CNAV:EPHemeris:CRC.....	536
[:SOURCE<hw>]:BB:GNSS:SVID<ch>:QZSS:NMESsage:CNAV:EPHemeris:CRC:UNSCaled.....	536
[:SOURCE<hw>]:BB:GNSS:SVID<ch>:QZSS:NMESsage:CNAV:EPHemeris:CRS.....	537
[:SOURCE<hw>]:BB:GNSS:SVID<ch>:QZSS:NMESsage:CNAV:EPHemeris:CRS:UNSCaled.....	537
[:SOURCE<hw>]:BB:GNSS:SVID<ch>:QZSS:NMESsage:CNAV:EPHemeris:CUC.....	534
[:SOURCE<hw>]:BB:GNSS:SVID<ch>:QZSS:NMESsage:CNAV:EPHemeris:CUC:UNSCaled.....	534
[:SOURCE<hw>]:BB:GNSS:SVID<ch>:QZSS:NMESsage:CNAV:EPHemeris:CUS.....	535
[:SOURCE<hw>]:BB:GNSS:SVID<ch>:QZSS:NMESsage:CNAV:EPHemeris:CUS:UNSCaled.....	535
[:SOURCE<hw>]:BB:GNSS:SVID<ch>:QZSS:NMESsage:CNAV:EPHemeris:DNDot.....	530
[:SOURCE<hw>]:BB:GNSS:SVID<ch>:QZSS:NMESsage:CNAV:EPHemeris:DNDot:UNSCaled.....	530
[:SOURCE<hw>]:BB:GNSS:SVID<ch>:QZSS:NMESsage:CNAV:EPHemeris:DODot.....	529
[:SOURCE<hw>]:BB:GNSS:SVID<ch>:QZSS:NMESsage:CNAV:EPHemeris:DODot:UNSCaled.....	529
[:SOURCE<hw>]:BB:GNSS:SVID<ch>:QZSS:NMESsage:CNAV:EPHemeris:ECCentricity.....	523
[:SOURCE<hw>]:BB:GNSS:SVID<ch>:QZSS:NMESsage:CNAV:EPHemeris:ECCentricity:UNSCaled.....	523
[:SOURCE<hw>]:BB:GNSS:SVID<ch>:QZSS:NMESsage:CNAV:EPHemeris:IDOT.....	528
[:SOURCE<hw>]:BB:GNSS:SVID<ch>:QZSS:NMESsage:CNAV:EPHemeris:IDOT:UNSCaled.....	527
[:SOURCE<hw>]:BB:GNSS:SVID<ch>:QZSS:NMESsage:CNAV:EPHemeris:ISFLag.....	546
[:SOURCE<hw>]:BB:GNSS:SVID<ch>:QZSS:NMESsage:CNAV:EPHemeris:IZERo.....	524
[:SOURCE<hw>]:BB:GNSS:SVID<ch>:QZSS:NMESsage:CNAV:EPHemeris:IZERo:UNSCaled.....	524
[:SOURCE<hw>]:BB:GNSS:SVID<ch>:QZSS:NMESsage:CNAV:EPHemeris:L1Health.....	545
[:SOURCE<hw>]:BB:GNSS:SVID<ch>:QZSS:NMESsage:CNAV:EPHemeris:L2CPhasing.....	546
[:SOURCE<hw>]:BB:GNSS:SVID<ch>:QZSS:NMESsage:CNAV:EPHemeris:L2Health.....	545
[:SOURCE<hw>]:BB:GNSS:SVID<ch>:QZSS:NMESsage:CNAV:EPHemeris:L5Health.....	545
[:SOURCE<hw>]:BB:GNSS:SVID<ch>:QZSS:NMESsage:CNAV:EPHemeris:MZERo.....	527
[:SOURCE<hw>]:BB:GNSS:SVID<ch>:QZSS:NMESsage:CNAV:EPHemeris:MZERo:UNSCaled.....	527
[:SOURCE<hw>]:BB:GNSS:SVID<ch>:QZSS:NMESsage:CNAV:EPHemeris:NDELta.....	530
[:SOURCE<hw>]:BB:GNSS:SVID<ch>:QZSS:NMESsage:CNAV:EPHemeris:NDELta:UNSCaled.....	530
[:SOURCE<hw>]:BB:GNSS:SVID<ch>:QZSS:NMESsage:CNAV:EPHemeris:NED0.....	545
[:SOURCE<hw>]:BB:GNSS:SVID<ch>:QZSS:NMESsage:CNAV:EPHemeris:NED1.....	545
[:SOURCE<hw>]:BB:GNSS:SVID<ch>:QZSS:NMESsage:CNAV:EPHemeris:NED2.....	545
[:SOURCE<hw>]:BB:GNSS:SVID<ch>:QZSS:NMESsage:CNAV:EPHemeris:ODOT.....	528
[:SOURCE<hw>]:BB:GNSS:SVID<ch>:QZSS:NMESsage:CNAV:EPHemeris:ODOT:UNSCaled.....	528
[:SOURCE<hw>]:BB:GNSS:SVID<ch>:QZSS:NMESsage:CNAV:EPHemeris:OMEGa.....	526
[:SOURCE<hw>]:BB:GNSS:SVID<ch>:QZSS:NMESsage:CNAV:EPHemeris:OMEGa:UNSCaled.....	526
[:SOURCE<hw>]:BB:GNSS:SVID<ch>:QZSS:NMESsage:CNAV:EPHemeris:OZERo.....	525
[:SOURCE<hw>]:BB:GNSS:SVID<ch>:QZSS:NMESsage:CNAV:EPHemeris:OZERo:UNSCaled.....	525
[:SOURCE<hw>]:BB:GNSS:SVID<ch>:QZSS:NMESsage:CNAV:EPHemeris:SQRA.....	522
[:SOURCE<hw>]:BB:GNSS:SVID<ch>:QZSS:NMESsage:CNAV:EPHemeris:SQRA:UNSCaled.....	522
[:SOURCE<hw>]:BB:GNSS:SVID<ch>:QZSS:NMESsage:CNAV:EPHemeris:TOE.....	521

[:SOURCE<hw>]:BB:GNSS:SVID<ch>:QZSS:NMESsage:CNAV:EPHemeris:TOE:UNSCaled.....	521
[:SOURCE<hw>]:BB:GNSS:SVID<ch>:QZSS:NMESsage:CNAV:EPHemeris:URA.....	547
[:SOURCE<hw>]:BB:GNSS:SVID<ch>:QZSS:NMESsage:NAV:CCORrection:AF<s2us0>.....	541
[:SOURCE<hw>]:BB:GNSS:SVID<ch>:QZSS:NMESsage:NAV:CCORrection:AF<s2us0>:UNSCaled.....	541
[:SOURCE<hw>]:BB:GNSS:SVID<ch>:QZSS:NMESsage:NAV:CCORrection:TGD.....	542
[:SOURCE<hw>]:BB:GNSS:SVID<ch>:QZSS:NMESsage:NAV:CCORrection:TGD:UNSCaled.....	542
[:SOURCE<hw>]:BB:GNSS:SVID<ch>:QZSS:NMESsage:NAV:CCORrection:TOC.....	540
[:SOURCE<hw>]:BB:GNSS:SVID<ch>:QZSS:NMESsage:NAV:CCORrection:TOC:UNSCaled.....	540
[:SOURCE<hw>]:BB:GNSS:SVID<ch>:QZSS:NMESsage:NAV:EPHemeris:AODO?.....	549
[:SOURCE<hw>]:BB:GNSS:SVID<ch>:QZSS:NMESsage:NAV:EPHemeris:CIC.....	538
[:SOURCE<hw>]:BB:GNSS:SVID<ch>:QZSS:NMESsage:NAV:EPHemeris:CIC:UNSCaled.....	538
[:SOURCE<hw>]:BB:GNSS:SVID<ch>:QZSS:NMESsage:NAV:EPHemeris:CIS.....	539
[:SOURCE<hw>]:BB:GNSS:SVID<ch>:QZSS:NMESsage:NAV:EPHemeris:CIS:UNSCaled.....	539
[:SOURCE<hw>]:BB:GNSS:SVID<ch>:QZSS:NMESsage:NAV:EPHemeris:CLTMode.....	548
[:SOURCE<hw>]:BB:GNSS:SVID<ch>:QZSS:NMESsage:NAV:EPHemeris:CRC.....	536
[:SOURCE<hw>]:BB:GNSS:SVID<ch>:QZSS:NMESsage:NAV:EPHemeris:CRC:UNSCaled.....	536
[:SOURCE<hw>]:BB:GNSS:SVID<ch>:QZSS:NMESsage:NAV:EPHemeris:CRS.....	537
[:SOURCE<hw>]:BB:GNSS:SVID<ch>:QZSS:NMESsage:NAV:EPHemeris:CRS:UNSCaled.....	537
[:SOURCE<hw>]:BB:GNSS:SVID<ch>:QZSS:NMESsage:NAV:EPHemeris:CUC.....	534
[:SOURCE<hw>]:BB:GNSS:SVID<ch>:QZSS:NMESsage:NAV:EPHemeris:CUC:UNSCaled.....	534
[:SOURCE<hw>]:BB:GNSS:SVID<ch>:QZSS:NMESsage:NAV:EPHemeris:CUS.....	535
[:SOURCE<hw>]:BB:GNSS:SVID<ch>:QZSS:NMESsage:NAV:EPHemeris:CUS:UNSCaled.....	535
[:SOURCE<hw>]:BB:GNSS:SVID<ch>:QZSS:NMESsage:NAV:EPHemeris:ECCentricity.....	523
[:SOURCE<hw>]:BB:GNSS:SVID<ch>:QZSS:NMESsage:NAV:EPHemeris:ECCentricity:UNSCaled.....	523
[:SOURCE<hw>]:BB:GNSS:SVID<ch>:QZSS:NMESsage:NAV:EPHemeris:FIFLag.....	549
[:SOURCE<hw>]:BB:GNSS:SVID<ch>:QZSS:NMESsage:NAV:EPHemeris:HEALTH.....	547
[:SOURCE<hw>]:BB:GNSS:SVID<ch>:QZSS:NMESsage:NAV:EPHemeris:IDOT.....	528
[:SOURCE<hw>]:BB:GNSS:SVID<ch>:QZSS:NMESsage:NAV:EPHemeris:IDOT:UNSCaled.....	528
[:SOURCE<hw>]:BB:GNSS:SVID<ch>:QZSS:NMESsage:NAV:EPHemeris:IODC.....	540
[:SOURCE<hw>]:BB:GNSS:SVID<ch>:QZSS:NMESsage:NAV:EPHemeris:IODE.....	521
[:SOURCE<hw>]:BB:GNSS:SVID<ch>:QZSS:NMESsage:NAV:EPHemeris:IZERo.....	524
[:SOURCE<hw>]:BB:GNSS:SVID<ch>:QZSS:NMESsage:NAV:EPHemeris:IZERo:UNSCaled.....	524
[:SOURCE<hw>]:BB:GNSS:SVID<ch>:QZSS:NMESsage:NAV:EPHemeris:LTPData.....	548
[:SOURCE<hw>]:BB:GNSS:SVID<ch>:QZSS:NMESsage:NAV:EPHemeris:MZERo.....	527
[:SOURCE<hw>]:BB:GNSS:SVID<ch>:QZSS:NMESsage:NAV:EPHemeris:MZERo:UNSCaled.....	527
[:SOURCE<hw>]:BB:GNSS:SVID<ch>:QZSS:NMESsage:NAV:EPHemeris:NDELta.....	530
[:SOURCE<hw>]:BB:GNSS:SVID<ch>:QZSS:NMESsage:NAV:EPHemeris:NDELta:UNSCaled.....	530
[:SOURCE<hw>]:BB:GNSS:SVID<ch>:QZSS:NMESsage:NAV:EPHemeris:ODOT.....	528
[:SOURCE<hw>]:BB:GNSS:SVID<ch>:QZSS:NMESsage:NAV:EPHemeris:ODOT:UNSCaled.....	528
[:SOURCE<hw>]:BB:GNSS:SVID<ch>:QZSS:NMESsage:NAV:EPHemeris:OMEGa.....	526
[:SOURCE<hw>]:BB:GNSS:SVID<ch>:QZSS:NMESsage:NAV:EPHemeris:OMEGa:UNSCaled.....	526
[:SOURCE<hw>]:BB:GNSS:SVID<ch>:QZSS:NMESsage:NAV:EPHemeris:OZERo.....	525
[:SOURCE<hw>]:BB:GNSS:SVID<ch>:QZSS:NMESsage:NAV:EPHemeris:OZERo:UNSCaled.....	525
[:SOURCE<hw>]:BB:GNSS:SVID<ch>:QZSS:NMESsage:NAV:EPHemeris:SF1Reserved<s2us>?.....	549
[:SOURCE<hw>]:BB:GNSS:SVID<ch>:QZSS:NMESsage:NAV:EPHemeris:SQRA.....	522
[:SOURCE<hw>]:BB:GNSS:SVID<ch>:QZSS:NMESsage:NAV:EPHemeris:SQRA:UNSCaled.....	522
[:SOURCE<hw>]:BB:GNSS:SVID<ch>:QZSS:NMESsage:NAV:EPHemeris:SVConfig.....	548
[:SOURCE<hw>]:BB:GNSS:SVID<ch>:QZSS:NMESsage:NAV:EPHemeris:TOE.....	521
[:SOURCE<hw>]:BB:GNSS:SVID<ch>:QZSS:NMESsage:NAV:EPHemeris:TOE:UNSCaled.....	521
[:SOURCE<hw>]:BB:GNSS:SVID<ch>:QZSS:NMESsage:NAV:EPHemeris:URA.....	547

[:SOURce<hw>]:BB:GNSS:SVID<ch>:QZSS:POWer:COpy:EXECute.....	463
[:SOURce<hw>]:BB:GNSS:SVID<ch>:QZSS:POWer:COpy:SVID.....	462
[:SOURce<hw>]:BB:GNSS:SVID<ch>:QZSS:POWer:OFFSet.....	460
[:SOURce<hw>]:BB:GNSS:SVID<ch>:QZSS:POWer:PLoSs.....	460
[:SOURce<hw>]:BB:GNSS:SVID<ch>:QZSS:PRERrors:COpy:EXECute.....	495
[:SOURce<hw>]:BB:GNSS:SVID<ch>:QZSS:PRERrors:COpy:SVID.....	494
[:SOURce<hw>]:BB:GNSS:SVID<ch>:QZSS:PRERrors:FILE.....	494
[:SOURce<hw>]:BB:GNSS:SVID<ch>:QZSS:PRERrors:MODE.....	493
[:SOURce<hw>]:BB:GNSS:SVID<ch>:QZSS:PRERrors:PROFile:APPend.....	497
[:SOURce<hw>]:BB:GNSS:SVID<ch>:QZSS:PRERrors:PROFile:COUnT?.....	496
[:SOURce<hw>]:BB:GNSS:SVID<ch>:QZSS:PRERrors:PROFile:OFFSet.....	496
[:SOURce<hw>]:BB:GNSS:SVID<ch>:QZSS:PRERrors:PROFile<gr>:DELete.....	499
[:SOURce<hw>]:BB:GNSS:SVID<ch>:QZSS:PRERrors:PROFile<gr>:INSert.....	499
[:SOURce<hw>]:BB:GNSS:SVID<ch>:QZSS:PRERrors:PROFile<gr>:REFerence.....	497
[:SOURce<hw>]:BB:GNSS:SVID<ch>:QZSS:PRERrors:PROFile<gr>:VALue.....	498
[:SOURce<hw>]:BB:GNSS:SVID<ch>:QZSS:PRERrors:VALue.....	495
[:SOURce<hw>]:BB:GNSS:SVID<ch>:QZSS:PRESent.....	459
[:SOURce<hw>]:BB:GNSS:SVID<ch>:QZSS:SDYNamics:ACCel:MAX.....	595
[:SOURce<hw>]:BB:GNSS:SVID<ch>:QZSS:SDYNamics:CAPeriod.....	594
[:SOURce<hw>]:BB:GNSS:SVID<ch>:QZSS:SDYNamics:CONFig.....	593
[:SOURce<hw>]:BB:GNSS:SVID<ch>:QZSS:SDYNamics:CPHase.....	591
[:SOURce<hw>]:BB:GNSS:SVID<ch>:QZSS:SDYNamics:CVPerioD.....	594
[:SOURce<hw>]:BB:GNSS:SVID<ch>:QZSS:SDYNamics:IVELocity.....	592
[:SOURce<hw>]:BB:GNSS:SVID<ch>:QZSS:SDYNamics:JERK:MAX.....	595
[:SOURce<hw>]:BB:GNSS:SVID<ch>:QZSS:SDYNamics:PRANge.....	591
[:SOURce<hw>]:BB:GNSS:SVID<ch>:QZSS:SDYNamics:PROFile.....	590
[:SOURce<hw>]:BB:GNSS:SVID<ch>:QZSS:SDYNamics:RPERioD?.....	596
[:SOURce<hw>]:BB:GNSS:SVID<ch>:QZSS:SDYNamics:TOFFset.....	592
[:SOURce<hw>]:BB:GNSS:SVID<ch>:QZSS:SDYNamics:VELocity.....	592
[:SOURce<hw>]:BB:GNSS:SVID<ch>:QZSS:SIGNal:L1Band:CA:DATA:NMESsage:CONTRol.....	469
[:SOURce<hw>]:BB:GNSS:SVID<ch>:QZSS:SIGNal:L1Band:CA:DATA:NMESsage:DSElect.....	473
[:SOURce<hw>]:BB:GNSS:SVID<ch>:QZSS:SIGNal:L1Band:CA:DATA:NMESsage:PATtern.....	475
[:SOURce<hw>]:BB:GNSS:SVID<ch>:QZSS:SIGNal:L1Band:CA:DATA:NMESsage:TYPE.....	471
[:SOURce<hw>]:BB:GNSS:SVID<ch>:QZSS:SIGNal:L1Band:CA:DATA:NMESsage[:STATe].....	589
[:SOURce<hw>]:BB:GNSS:SVID<ch>:QZSS:SIGNal:L1Band:CA:DATA:PCODE[:STATe].....	465
[:SOURce<hw>]:BB:GNSS:SVID<ch>:QZSS:SIGNal:L1Band:CA:PILot:PCODE[:STATe].....	465
[:SOURce<hw>]:BB:GNSS:SVID<ch>:QZSS:SIGNal:L1Band:CA:POWer:OFFset.....	461
[:SOURce<hw>]:BB:GNSS:SVID<ch>:QZSS:SIGNal:L1Band:CA[:STATe].....	464
[:SOURce<hw>]:BB:GNSS:SVID<ch>:QZSS:SIGNal:L1Band:L1C:DATA:NMESsage:CONTRol.....	469
[:SOURce<hw>]:BB:GNSS:SVID<ch>:QZSS:SIGNal:L1Band:L1C:DATA:NMESsage:DSElect.....	473
[:SOURce<hw>]:BB:GNSS:SVID<ch>:QZSS:SIGNal:L1Band:L1C:DATA:NMESsage:PATtern.....	475
[:SOURce<hw>]:BB:GNSS:SVID<ch>:QZSS:SIGNal:L1Band:L1C:DATA:NMESsage:TYPE.....	471
[:SOURce<hw>]:BB:GNSS:SVID<ch>:QZSS:SIGNal:L1Band:L1C:DATA:NMESsage[:STATe].....	589
[:SOURce<hw>]:BB:GNSS:SVID<ch>:QZSS:SIGNal:L1Band:L1C:DATA:PCODE[:STATe].....	465
[:SOURce<hw>]:BB:GNSS:SVID<ch>:QZSS:SIGNal:L1Band:L1C:PILot:PCODE[:STATe].....	465
[:SOURce<hw>]:BB:GNSS:SVID<ch>:QZSS:SIGNal:L1Band:L1C:PILot:SCODE[:STATe].....	467
[:SOURce<hw>]:BB:GNSS:SVID<ch>:QZSS:SIGNal:L1Band:L1C:POWer:OFFset.....	461
[:SOURce<hw>]:BB:GNSS:SVID<ch>:QZSS:SIGNal:L1Band:L1C[:STATe].....	464
[:SOURce<hw>]:BB:GNSS:SVID<ch>:QZSS:SIGNal:L2Band:L2C:DATA:NMESsage:CONTRol.....	469
[:SOURce<hw>]:BB:GNSS:SVID<ch>:QZSS:SIGNal:L2Band:L2C:DATA:NMESsage:DSElect.....	473

[:SOURCE<hw>]:BB:GNSS:SVID<ch>:QZSS:SIGNal:L2Band:L2C:DATA:NMESSage:PATtern.....	475
[:SOURCE<hw>]:BB:GNSS:SVID<ch>:QZSS:SIGNal:L2Band:L2C:DATA:NMESSage:TYPE.....	471
[:SOURCE<hw>]:BB:GNSS:SVID<ch>:QZSS:SIGNal:L2Band:L2C:DATA:NMESSage[:STATe].....	589
[:SOURCE<hw>]:BB:GNSS:SVID<ch>:QZSS:SIGNal:L2Band:L2C:DATA:PCODE[:STATe].....	465
[:SOURCE<hw>]:BB:GNSS:SVID<ch>:QZSS:SIGNal:L2Band:L2C:PILot:PCODE[:STATe].....	465
[:SOURCE<hw>]:BB:GNSS:SVID<ch>:QZSS:SIGNal:L2Band:L2C:POWer:OFFset.....	461
[:SOURCE<hw>]:BB:GNSS:SVID<ch>:QZSS:SIGNal:L2Band:L2C[:STATe].....	464
[:SOURCE<hw>]:BB:GNSS:SVID<ch>:QZSS:SIGNal:L5Band:L5S:DATA:NMESSage:CONTRol.....	469
[:SOURCE<hw>]:BB:GNSS:SVID<ch>:QZSS:SIGNal:L5Band:L5S:DATA:NMESSage:DSElect.....	473
[:SOURCE<hw>]:BB:GNSS:SVID<ch>:QZSS:SIGNal:L5Band:L5S:DATA:NMESSage:PATtern.....	475
[:SOURCE<hw>]:BB:GNSS:SVID<ch>:QZSS:SIGNal:L5Band:L5S:DATA:NMESSage:TYPE.....	471
[:SOURCE<hw>]:BB:GNSS:SVID<ch>:QZSS:SIGNal:L5Band:L5S:DATA:NMESSage[:STATe].....	589
[:SOURCE<hw>]:BB:GNSS:SVID<ch>:QZSS:SIGNal:L5Band:L5S:DATA:PCODE[:STATe].....	465
[:SOURCE<hw>]:BB:GNSS:SVID<ch>:QZSS:SIGNal:L5Band:L5S:DATA:SCODE[:STATe].....	467
[:SOURCE<hw>]:BB:GNSS:SVID<ch>:QZSS:SIGNal:L5Band:L5S:PILot:PCODE[:STATe].....	465
[:SOURCE<hw>]:BB:GNSS:SVID<ch>:QZSS:SIGNal:L5Band:L5S:PILot:SCODE[:STATe].....	467
[:SOURCE<hw>]:BB:GNSS:SVID<ch>:QZSS:SIGNal:L5Band:L5S:POWer:OFFset.....	461
[:SOURCE<hw>]:BB:GNSS:SVID<ch>:QZSS:SIGNal:L5Band:L5S[:STATe].....	463
[:SOURCE<hw>]:BB:GNSS:SVID<ch>:QZSS:SIMulated:CLOCK:AF<s2us0>.....	490
[:SOURCE<hw>]:BB:GNSS:SVID<ch>:QZSS:SIMulated:CLOCK:TGD.....	491
[:SOURCE<hw>]:BB:GNSS:SVID<ch>:QZSS:SIMulated:CLOCK:TOC.....	490
[:SOURCE<hw>]:BB:GNSS:SVID<ch>:QZSS:SIMulated:CLOCK:WNOC.....	490
[:SOURCE<hw>]:BB:GNSS:SVID<ch>:QZSS:SIMulated:ORBit:CIC.....	489
[:SOURCE<hw>]:BB:GNSS:SVID<ch>:QZSS:SIMulated:ORBit:CIS.....	489
[:SOURCE<hw>]:BB:GNSS:SVID<ch>:QZSS:SIMulated:ORBit:CRC.....	489
[:SOURCE<hw>]:BB:GNSS:SVID<ch>:QZSS:SIMulated:ORBit:CRS.....	489
[:SOURCE<hw>]:BB:GNSS:SVID<ch>:QZSS:SIMulated:ORBit:CUC.....	488
[:SOURCE<hw>]:BB:GNSS:SVID<ch>:QZSS:SIMulated:ORBit:CUS.....	488
[:SOURCE<hw>]:BB:GNSS:SVID<ch>:QZSS:SIMulated:ORBit:ECCentricity.....	486
[:SOURCE<hw>]:BB:GNSS:SVID<ch>:QZSS:SIMulated:ORBit:IDOT.....	487
[:SOURCE<hw>]:BB:GNSS:SVID<ch>:QZSS:SIMulated:ORBit:IZERo.....	486
[:SOURCE<hw>]:BB:GNSS:SVID<ch>:QZSS:SIMulated:ORBit:MZERo.....	487
[:SOURCE<hw>]:BB:GNSS:SVID<ch>:QZSS:SIMulated:ORBit:NDELta.....	488
[:SOURCE<hw>]:BB:GNSS:SVID<ch>:QZSS:SIMulated:ORBit:ODOT.....	488
[:SOURCE<hw>]:BB:GNSS:SVID<ch>:QZSS:SIMulated:ORBit:OMEGa.....	487
[:SOURCE<hw>]:BB:GNSS:SVID<ch>:QZSS:SIMulated:ORBit:OZERo.....	486
[:SOURCE<hw>]:BB:GNSS:SVID<ch>:QZSS:SIMulated:ORBit:SQRA.....	485
[:SOURCE<hw>]:BB:GNSS:SVID<ch>:QZSS:SIMulated:ORBit:TOE.....	484
[:SOURCE<hw>]:BB:GNSS:SVID<ch>:QZSS:SIMulated:ORBit:WNOE.....	484
[:SOURCE<hw>]:BB:GNSS:SVID<ch>:QZSS:STATe.....	458
[:SOURCE<hw>]:BB:GNSS:SVID<ch>:QZSS:VISibility:STATe?.....	446
[:SOURCE<hw>]:BB:GNSS:SVID<ch>:SBAS:HEALTHy.....	444
[:SOURCE<hw>]:BB:GNSS:SVID<ch>:SBAS:MCONtrol:COPY:EXECute.....	478
[:SOURCE<hw>]:BB:GNSS:SVID<ch>:SBAS:MCONtrol:COPY:SVID.....	477
[:SOURCE<hw>]:BB:GNSS:SVID<ch>:SBAS:MPATH[:V<us>:A<gr>]:ECHO<s2us0>:AAZimuth.....	427
[:SOURCE<hw>]:BB:GNSS:SVID<ch>:SBAS:MPATH[:V<us>:A<gr>]:ECHO<s2us0>:AELEVation.....	427
[:SOURCE<hw>]:BB:GNSS:SVID<ch>:SBAS:MPATH[:V<us>:A<gr>]:ECHO<s2us0>:CPDRift.....	423
[:SOURCE<hw>]:BB:GNSS:SVID<ch>:SBAS:MPATH[:V<us>:A<gr>]:ECHO<s2us0>:CPHase.....	425
[:SOURCE<hw>]:BB:GNSS:SVID<ch>:SBAS:MPATH[:V<us>:A<gr>]:ECHO<s2us0>:DSHift.....	426
[:SOURCE<hw>]:BB:GNSS:SVID<ch>:SBAS:MPATH[:V<us>:A<gr>]:ECHO<s2us0>:ICPHase.....	423

[:SOURce<hw>]:BB:GNSS:SVID<ch>:SBAS:MPATH[V<us>:A<gr>]:ECHO<s2us0>:POWER.....	424
[:SOURce<hw>]:BB:GNSS:SVID<ch>:SBAS:MPATH[V<us>:A<gr>]:ECHOs:COUNT.....	422
[:SOURce<hw>]:BB:GNSS:SVID<ch>:SBAS:MPATH[V<us>:A<gr>]:LOS:AAZimuth?.....	427
[:SOURce<hw>]:BB:GNSS:SVID<ch>:SBAS:MPATH[V<us>:A<gr>]:LOS:AELEVation?.....	427
[:SOURce<hw>]:BB:GNSS:SVID<ch>:SBAS:MPATH[V<us>:A<gr>]:LOS:CPDRift?.....	423
[:SOURce<hw>]:BB:GNSS:SVID<ch>:SBAS:MPATH[V<us>:A<gr>]:LOS:CPHase?.....	425
[:SOURce<hw>]:BB:GNSS:SVID<ch>:SBAS:MPATH[V<us>:A<gr>]:LOS:DSHift?.....	426
[:SOURce<hw>]:BB:GNSS:SVID<ch>:SBAS:MPATH[V<us>:A<gr>]:LOS:ENABLE.....	421
[:SOURce<hw>]:BB:GNSS:SVID<ch>:SBAS:MPATH[V<us>:A<gr>]:LOS:ICPHase?.....	422
[:SOURce<hw>]:BB:GNSS:SVID<ch>:SBAS:MPATH[V<us>:A<gr>]:LOS:POWER?.....	424
[:SOURce<hw>]:BB:GNSS:SVID<ch>:SBAS:NMESsage:NAV:CCORrection:AF<s2us0>.....	541
[:SOURce<hw>]:BB:GNSS:SVID<ch>:SBAS:NMESsage:NAV:CCORrection:AF<s2us0>:UNSCaled.....	541
[:SOURce<hw>]:BB:GNSS:SVID<ch>:SBAS:NMESsage:NAV:EPHemeris:TOE.....	521
[:SOURce<hw>]:BB:GNSS:SVID<ch>:SBAS:NMESsage:NAV:EPHemeris:TOE:UNSCaled.....	521
[:SOURce<hw>]:BB:GNSS:SVID<ch>:SBAS:NMESsage:NAV:EPHemeris:URA.....	547
[:SOURce<hw>]:BB:GNSS:SVID<ch>:SBAS:NMESsage:NAV:EPHemeris:XDDN.....	534
[:SOURce<hw>]:BB:GNSS:SVID<ch>:SBAS:NMESsage:NAV:EPHemeris:XDDN:UNSCaled.....	534
[:SOURce<hw>]:BB:GNSS:SVID<ch>:SBAS:NMESsage:NAV:EPHemeris:XDN.....	533
[:SOURce<hw>]:BB:GNSS:SVID<ch>:SBAS:NMESsage:NAV:EPHemeris:XDN:UNSCaled.....	533
[:SOURce<hw>]:BB:GNSS:SVID<ch>:SBAS:NMESsage:NAV:EPHemeris:YN.....	532
[:SOURce<hw>]:BB:GNSS:SVID<ch>:SBAS:NMESsage:NAV:EPHemeris:YN:UNSCaled.....	532
[:SOURce<hw>]:BB:GNSS:SVID<ch>:SBAS:NMESsage:NAV:EPHemeris:ZDDN.....	534
[:SOURce<hw>]:BB:GNSS:SVID<ch>:SBAS:NMESsage:NAV:EPHemeris:ZDDN:UNSCaled.....	534
[:SOURce<hw>]:BB:GNSS:SVID<ch>:SBAS:NMESsage:NAV:EPHemeris:ZDN.....	533
[:SOURce<hw>]:BB:GNSS:SVID<ch>:SBAS:NMESsage:NAV:EPHemeris:ZDN:UNSCaled.....	533
[:SOURce<hw>]:BB:GNSS:SVID<ch>:SBAS:NMESsage:NAV:EPHemeris:ZN.....	532
[:SOURce<hw>]:BB:GNSS:SVID<ch>:SBAS:NMESsage:NAV:EPHemeris:ZN:UNSCaled.....	532
[:SOURce<hw>]:BB:GNSS:SVID<ch>:SBAS:POWER:COPY:EXECute.....	463
[:SOURce<hw>]:BB:GNSS:SVID<ch>:SBAS:POWER:COPY:SVID.....	462
[:SOURce<hw>]:BB:GNSS:SVID<ch>:SBAS:POWER:OFFSet.....	460
[:SOURce<hw>]:BB:GNSS:SVID<ch>:SBAS:POWER:PLOs.....	460
[:SOURce<hw>]:BB:GNSS:SVID<ch>:SBAS:PRERrors:COPY:EXECute.....	495
[:SOURce<hw>]:BB:GNSS:SVID<ch>:SBAS:PRERrors:COPY:SVID.....	494
[:SOURce<hw>]:BB:GNSS:SVID<ch>:SBAS:PRERrors:FILE.....	494
[:SOURce<hw>]:BB:GNSS:SVID<ch>:SBAS:PRERrors:MODE.....	493
[:SOURce<hw>]:BB:GNSS:SVID<ch>:SBAS:PRERrors:PROFile:APPend.....	497
[:SOURce<hw>]:BB:GNSS:SVID<ch>:SBAS:PRERrors:PROFile:COUNT?.....	496
[:SOURce<hw>]:BB:GNSS:SVID<ch>:SBAS:PRERrors:PROFile:OFFSet.....	496
[:SOURce<hw>]:BB:GNSS:SVID<ch>:SBAS:PRERrors:PROFile<gr>:DELeTe.....	499
[:SOURce<hw>]:BB:GNSS:SVID<ch>:SBAS:PRERrors:PROFile<gr>:INSert.....	499
[:SOURce<hw>]:BB:GNSS:SVID<ch>:SBAS:PRERrors:PROFile<gr>:REFerence.....	497
[:SOURce<hw>]:BB:GNSS:SVID<ch>:SBAS:PRERrors:PROFile<gr>:REFerence.....	498
[:SOURce<hw>]:BB:GNSS:SVID<ch>:SBAS:PRERrors:PROFile<gr>:VALue.....	498
[:SOURce<hw>]:BB:GNSS:SVID<ch>:SBAS:PRERrors:VALue.....	496

[:SOURce<hw>]:BB:GNSS:SVID<ch>:SBAS:PRESet	459
[:SOURce<hw>]:BB:GNSS:SVID<ch>:SBAS:SDYnAmics:ACCel:MAX	595
[:SOURce<hw>]:BB:GNSS:SVID<ch>:SBAS:SDYnAmics:CAPeriod	594
[:SOURce<hw>]:BB:GNSS:SVID<ch>:SBAS:SDYnAmics:CONFig	593
[:SOURce<hw>]:BB:GNSS:SVID<ch>:SBAS:SDYnAmics:CPHase	591
[:SOURce<hw>]:BB:GNSS:SVID<ch>:SBAS:SDYnAmics:CVPeriod	594
[:SOURce<hw>]:BB:GNSS:SVID<ch>:SBAS:SDYnAmics:IVELocity	592
[:SOURce<hw>]:BB:GNSS:SVID<ch>:SBAS:SDYnAmics:JERK:MAX	595
[:SOURce<hw>]:BB:GNSS:SVID<ch>:SBAS:SDYnAmics:PRANge	591
[:SOURce<hw>]:BB:GNSS:SVID<ch>:SBAS:SDYnAmics:PROFile	590
[:SOURce<hw>]:BB:GNSS:SVID<ch>:SBAS:SDYnAmics:RPERiod?	596
[:SOURce<hw>]:BB:GNSS:SVID<ch>:SBAS:SDYnAmics:TOFFset	592
[:SOURce<hw>]:BB:GNSS:SVID<ch>:SBAS:SDYnAmics:VELocity	592
[:SOURce<hw>]:BB:GNSS:SVID<ch>:SBAS:SIGNal:L1Band:CA:DATA:NMESsage:CONTRol	469
[:SOURce<hw>]:BB:GNSS:SVID<ch>:SBAS:SIGNal:L1Band:CA:DATA:NMESsage:DSElect	473
[:SOURce<hw>]:BB:GNSS:SVID<ch>:SBAS:SIGNal:L1Band:CA:DATA:NMESsage:PATtern	475
[:SOURce<hw>]:BB:GNSS:SVID<ch>:SBAS:SIGNal:L1Band:CA:DATA:NMESsage:TYPE	471
[:SOURce<hw>]:BB:GNSS:SVID<ch>:SBAS:SIGNal:L1Band:CA:DATA:NMESsage[:STATe]	589
[:SOURce<hw>]:BB:GNSS:SVID<ch>:SBAS:SIGNal:L1Band:CA:DATA:PCODE[:STATe]	465
[:SOURce<hw>]:BB:GNSS:SVID<ch>:SBAS:SIGNal:L1Band:CA:POWEr:OFFset	461
[:SOURce<hw>]:BB:GNSS:SVID<ch>:SBAS:SIGNal:L1Band:CA[:STATe]	463
[:SOURce<hw>]:BB:GNSS:SVID<ch>:SBAS:SIGNal:L5Band:EL5S:DATA:NMESsage:CONTRol	469
[:SOURce<hw>]:BB:GNSS:SVID<ch>:SBAS:SIGNal:L5Band:EL5S:DATA:NMESsage:DSElect	473
[:SOURce<hw>]:BB:GNSS:SVID<ch>:SBAS:SIGNal:L5Band:EL5S:DATA:NMESsage:PATtern	475
[:SOURce<hw>]:BB:GNSS:SVID<ch>:SBAS:SIGNal:L5Band:EL5S:DATA:NMESsage:TYPE	471
[:SOURce<hw>]:BB:GNSS:SVID<ch>:SBAS:SIGNal:L5Band:EL5S:DATA:NMESsage[:STATe]	589
[:SOURce<hw>]:BB:GNSS:SVID<ch>:SBAS:SIGNal:L5Band:EL5S:DATA:PCODE[:STATe]	465
[:SOURce<hw>]:BB:GNSS:SVID<ch>:SBAS:SIGNal:L5Band:EL5S:POWEr:OFFset	461
[:SOURce<hw>]:BB:GNSS:SVID<ch>:SBAS:SIGNal:L5Band:EL5S[:STATe]	463
[:SOURce<hw>]:BB:GNSS:SVID<ch>:SBAS:SIMulated:CLOCK:AF<s2us0>	490
[:SOURce<hw>]:BB:GNSS:SVID<ch>:SBAS:SIMulated:CLOCK:DATE	485
[:SOURce<hw>]:BB:GNSS:SVID<ch>:SBAS:SIMulated:CLOCK:TIME	485
[:SOURce<hw>]:BB:GNSS:SVID<ch>:SBAS:SIMulated:ORBit:DATE	485
[:SOURce<hw>]:BB:GNSS:SVID<ch>:SBAS:SIMulated:ORBit:TIME	485
[:SOURce<hw>]:BB:GNSS:SVID<ch>:SBAS:SIMulated:ORBit:XDDN	484
[:SOURce<hw>]:BB:GNSS:SVID<ch>:SBAS:SIMulated:ORBit:XDN	483
[:SOURce<hw>]:BB:GNSS:SVID<ch>:SBAS:SIMulated:ORBit:YN	483
[:SOURce<hw>]:BB:GNSS:SVID<ch>:SBAS:SIMulated:ORBit:YDDN	484
[:SOURce<hw>]:BB:GNSS:SVID<ch>:SBAS:SIMulated:ORBit:YDN	483
[:SOURce<hw>]:BB:GNSS:SVID<ch>:SBAS:SIMulated:ORBit:YN	483
[:SOURce<hw>]:BB:GNSS:SVID<ch>:SBAS:SIMulated:ORBit:ZDDN	484
[:SOURce<hw>]:BB:GNSS:SVID<ch>:SBAS:SIMulated:ORBit:ZDN	483
[:SOURce<hw>]:BB:GNSS:SVID<ch>:SBAS:SIMulated:ORBit:ZN	483
[:SOURce<hw>]:BB:GNSS:SVID<ch>:SBAS:STATe	458
[:SOURce<hw>]:BB:GNSS:SVID<ch>:SBAS:SYSTem	578
[:SOURce<hw>]:BB:GNSS:SVID<ch>:SBAS:VISibility:STATe?	446
[:SOURce<hw>]:BB:GNSS:SYSTem:BEIDou:SIGNal:L1Band:B1C[:STATe]	365
[:SOURce<hw>]:BB:GNSS:SYSTem:BEIDou:SIGNal:L1Band:B1I[:STATe]	365
[:SOURce<hw>]:BB:GNSS:SYSTem:BEIDou:SIGNal:L2Band:B3I[:STATe]	365
[:SOURce<hw>]:BB:GNSS:SYSTem:BEIDou:SIGNal:L5Band:B2A[:STATe]	365

[SOURce<hw>]:BB:GNSS:SYSTem:BEIDou:SIGNal:L5Band:B2B[:STATe].....	365
[SOURce<hw>]:BB:GNSS:SYSTem:BEIDou:SIGNal:L5Band:B2[:STATe].....	365
[SOURce<hw>]:BB:GNSS:SYSTem:BEIDou[:STATe].....	364
[SOURce<hw>]:BB:GNSS:SYSTem:GALileo:SIGNal:L1Band:E1OS[:STATe].....	365
[SOURce<hw>]:BB:GNSS:SYSTem:GALileo:SIGNal:L1Band:E1PRs[:STATe].....	365
[SOURce<hw>]:BB:GNSS:SYSTem:GALileo:SIGNal:L2Band:E6PRs[:STATe].....	365
[SOURce<hw>]:BB:GNSS:SYSTem:GALileo:SIGNal:L2Band:E6S[:STATe].....	365
[SOURce<hw>]:BB:GNSS:SYSTem:GALileo:SIGNal:L5Band:E5A[:STATe].....	365
[SOURce<hw>]:BB:GNSS:SYSTem:GALileo:SIGNal:L5Band:E5B[:STATe].....	365
[SOURce<hw>]:BB:GNSS:SYSTem:GALileo[:STATe].....	364
[SOURce<hw>]:BB:GNSS:SYSTem:GLONass:SIGNal:L1Band:CA[:STATe].....	365
[SOURce<hw>]:BB:GNSS:SYSTem:GLONass:SIGNal:L1Band:L1CDma[:STATe].....	365
[SOURce<hw>]:BB:GNSS:SYSTem:GLONass:SIGNal:L2Band:CA[:STATe].....	365
[SOURce<hw>]:BB:GNSS:SYSTem:GLONass:SIGNal:L2Band:L2CDma[:STATe].....	365
[SOURce<hw>]:BB:GNSS:SYSTem:GLONass:SIGNal:L5Band:L3CDma[:STATe].....	365
[SOURce<hw>]:BB:GNSS:SYSTem:GLONass[:STATe].....	364
[SOURce<hw>]:BB:GNSS:SYSTem:GPS:SIGNal:L1Band:CA[:STATe].....	366
[SOURce<hw>]:BB:GNSS:SYSTem:GPS:SIGNal:L1Band:L1C[:STATe].....	366
[SOURce<hw>]:BB:GNSS:SYSTem:GPS:SIGNal:L1Band:M[:STATe].....	366
[SOURce<hw>]:BB:GNSS:SYSTem:GPS:SIGNal:L1Band:P[:STATe].....	366
[SOURce<hw>]:BB:GNSS:SYSTem:GPS:SIGNal:L1Band:PY[:STATe].....	366
[SOURce<hw>]:BB:GNSS:SYSTem:GPS:SIGNal:L2Band:CA[:STATe].....	366
[SOURce<hw>]:BB:GNSS:SYSTem:GPS:SIGNal:L2Band:L2C[:STATe].....	366
[SOURce<hw>]:BB:GNSS:SYSTem:GPS:SIGNal:L2Band:M[:STATe].....	366
[SOURce<hw>]:BB:GNSS:SYSTem:GPS:SIGNal:L2Band:P[:STATe].....	366
[SOURce<hw>]:BB:GNSS:SYSTem:GPS:SIGNal:L2Band:PY[:STATe].....	366
[SOURce<hw>]:BB:GNSS:SYSTem:GPS:SIGNal:L5Band:L5S[:STATe].....	366
[SOURce<hw>]:BB:GNSS:SYSTem:GPS[:STATe].....	364
[SOURce<hw>]:BB:GNSS:SYSTem:NAVic:SIGNal:L5Band:SPS[:STATe].....	365
[SOURce<hw>]:BB:GNSS:SYSTem:NAVic[:STATe].....	364
[SOURce<hw>]:BB:GNSS:SYSTem:QZSS:SIGNal:L1Band:CA[:STATe].....	365
[SOURce<hw>]:BB:GNSS:SYSTem:QZSS:SIGNal:L1Band:L1C[:STATe].....	365
[SOURce<hw>]:BB:GNSS:SYSTem:QZSS:SIGNal:L2Band:L2C[:STATe].....	365
[SOURce<hw>]:BB:GNSS:SYSTem:QZSS:SIGNal:L5Band:L5S[:STATe].....	365
[SOURce<hw>]:BB:GNSS:SYSTem:QZSS[:STATe].....	364
[SOURce<hw>]:BB:GNSS:SYSTem:SBAS:EGNOS:NMESsage:NAV:ALManac:PERiod.....	583
[SOURce<hw>]:BB:GNSS:SYSTem:SBAS:EGNOS:NMESsage:NAV:ALManac:STATe.....	581
[SOURce<hw>]:BB:GNSS:SYSTem:SBAS:EGNOS:NMESsage:NAV:CECovariance:PERiod.....	582
[SOURce<hw>]:BB:GNSS:SYSTem:SBAS:EGNOS:NMESsage:NAV:CECovariance:STATe.....	580
[SOURce<hw>]:BB:GNSS:SYSTem:SBAS:EGNOS:NMESsage:NAV:DFACTor:PERiod.....	582
[SOURce<hw>]:BB:GNSS:SYSTem:SBAS:EGNOS:NMESsage:NAV:DFACTor:STATe.....	580
[SOURce<hw>]:BB:GNSS:SYSTem:SBAS:EGNOS:NMESsage:NAV:FCDegradation:PERiod.....	582
[SOURce<hw>]:BB:GNSS:SYSTem:SBAS:EGNOS:NMESsage:NAV:FCDegradation:STATe.....	580
[SOURce<hw>]:BB:GNSS:SYSTem:SBAS:EGNOS:NMESsage:NAV:FCORrection:PERiod.....	582
[SOURce<hw>]:BB:GNSS:SYSTem:SBAS:EGNOS:NMESsage:NAV:FCORrection:STATe.....	580
[SOURce<hw>]:BB:GNSS:SYSTem:SBAS:EGNOS:NMESsage:NAV:IGRid:PERiod.....	582
[SOURce<hw>]:BB:GNSS:SYSTem:SBAS:EGNOS:NMESsage:NAV:IGRid:STATe.....	580
[SOURce<hw>]:BB:GNSS:SYSTem:SBAS:EGNOS:NMESsage:NAV:LTCorrection:PERiod.....	582
[SOURce<hw>]:BB:GNSS:SYSTem:SBAS:EGNOS:NMESsage:NAV:LTCorrection:STATe.....	580
[SOURce<hw>]:BB:GNSS:SYSTem:SBAS:EGNOS:NMESsage:NAV:PRN<ch>:STATe.....	578

[:SOURCE<hw>]:BB:GNSS:SYSTEM:SBAS:EGNOS:NMESsage:NAV:PRNMask:PERiod.....	582
[:SOURCE<hw>]:BB:GNSS:SYSTEM:SBAS:EGNOS:NMESsage:NAV:PRNMask:STATe.....	580
[:SOURCE<hw>]:BB:GNSS:SYSTEM:SBAS:EGNOS:NMESsage:NAV:RINex:PERiod.....	582
[:SOURCE<hw>]:BB:GNSS:SYSTEM:SBAS:EGNOS:NMESsage:NAV:RINex:STATe.....	580
[:SOURCE<hw>]:BB:GNSS:SYSTEM:SBAS:EGNOS:NMESsage:NAV:SERVice:PERiod.....	582
[:SOURCE<hw>]:BB:GNSS:SYSTEM:SBAS:EGNOS:NMESsage:NAV:SERVice:STATe.....	581
[:SOURCE<hw>]:BB:GNSS:SYSTEM:SBAS:EGNOS:NMESsage:NAV:UTCOffset:PERiod.....	583
[:SOURCE<hw>]:BB:GNSS:SYSTEM:SBAS:EGNOS:NMESsage:NAV:UTCOffset:STATe?.....	581
[:SOURCE<hw>]:BB:GNSS:SYSTEM:SBAS:EGNOS[:STATe].....	364
[:SOURCE<hw>]:BB:GNSS:SYSTEM:SBAS:GAGAN:NMESsage:NAV:ALManac:PERiod.....	581
[:SOURCE<hw>]:BB:GNSS:SYSTEM:SBAS:GAGAN:NMESsage:NAV:ALManac:STATe.....	579
[:SOURCE<hw>]:BB:GNSS:SYSTEM:SBAS:GAGAN:NMESsage:NAV:CECovariance:PERiod.....	581
[:SOURCE<hw>]:BB:GNSS:SYSTEM:SBAS:GAGAN:NMESsage:NAV:CECovariance:STATe.....	579
[:SOURCE<hw>]:BB:GNSS:SYSTEM:SBAS:GAGAN:NMESsage:NAV:DFACTor:PERiod.....	581
[:SOURCE<hw>]:BB:GNSS:SYSTEM:SBAS:GAGAN:NMESsage:NAV:DFACTor:STATe.....	579
[:SOURCE<hw>]:BB:GNSS:SYSTEM:SBAS:GAGAN:NMESsage:NAV:FCDegradation:PERiod.....	581
[:SOURCE<hw>]:BB:GNSS:SYSTEM:SBAS:GAGAN:NMESsage:NAV:FCDegradation:STATe.....	579
[:SOURCE<hw>]:BB:GNSS:SYSTEM:SBAS:GAGAN:NMESsage:NAV:FCORrection:PERiod.....	581
[:SOURCE<hw>]:BB:GNSS:SYSTEM:SBAS:GAGAN:NMESsage:NAV:FCORrection:STATe.....	579
[:SOURCE<hw>]:BB:GNSS:SYSTEM:SBAS:GAGAN:NMESsage:NAV:IGRid:PERiod.....	581
[:SOURCE<hw>]:BB:GNSS:SYSTEM:SBAS:GAGAN:NMESsage:NAV:IGRid:STATe.....	579
[:SOURCE<hw>]:BB:GNSS:SYSTEM:SBAS:GAGAN:NMESsage:NAV:LTCorrection:PERiod.....	581
[:SOURCE<hw>]:BB:GNSS:SYSTEM:SBAS:GAGAN:NMESsage:NAV:LTCorrection:STATe.....	579
[:SOURCE<hw>]:BB:GNSS:SYSTEM:SBAS:GAGAN:NMESsage:NAV:PRN<ch>:STATe.....	578
[:SOURCE<hw>]:BB:GNSS:SYSTEM:SBAS:GAGAN:NMESsage:NAV:PRNMask:PERiod.....	581
[:SOURCE<hw>]:BB:GNSS:SYSTEM:SBAS:GAGAN:NMESsage:NAV:PRNMask:STATe.....	579
[:SOURCE<hw>]:BB:GNSS:SYSTEM:SBAS:GAGAN:NMESsage:NAV:RINex:PERiod.....	581
[:SOURCE<hw>]:BB:GNSS:SYSTEM:SBAS:GAGAN:NMESsage:NAV:RINex:STATe.....	579
[:SOURCE<hw>]:BB:GNSS:SYSTEM:SBAS:GAGAN:NMESsage:NAV:SERVice:PERiod.....	581
[:SOURCE<hw>]:BB:GNSS:SYSTEM:SBAS:GAGAN:NMESsage:NAV:SERVice:STATe.....	579
[:SOURCE<hw>]:BB:GNSS:SYSTEM:SBAS:GAGAN:NMESsage:NAV:UTCOffset:PERiod.....	581
[:SOURCE<hw>]:BB:GNSS:SYSTEM:SBAS:GAGAN:NMESsage:NAV:UTCOffset:STATe?.....	579
[:SOURCE<hw>]:BB:GNSS:SYSTEM:SBAS:GAGAN[:STATe].....	364
[:SOURCE<hw>]:BB:GNSS:SYSTEM:SBAS:MSAS:NMESsage:NAV:ALManac:PERiod.....	581
[:SOURCE<hw>]:BB:GNSS:SYSTEM:SBAS:MSAS:NMESsage:NAV:ALManac:STATe.....	579
[:SOURCE<hw>]:BB:GNSS:SYSTEM:SBAS:MSAS:NMESsage:NAV:CECovariance:PERiod.....	581
[:SOURCE<hw>]:BB:GNSS:SYSTEM:SBAS:MSAS:NMESsage:NAV:CECovariance:STATe.....	579
[:SOURCE<hw>]:BB:GNSS:SYSTEM:SBAS:MSAS:NMESsage:NAV:DFACTor:PERiod.....	581
[:SOURCE<hw>]:BB:GNSS:SYSTEM:SBAS:MSAS:NMESsage:NAV:DFACTor:STATe.....	579
[:SOURCE<hw>]:BB:GNSS:SYSTEM:SBAS:MSAS:NMESsage:NAV:FCDegradation:PERiod.....	581
[:SOURCE<hw>]:BB:GNSS:SYSTEM:SBAS:MSAS:NMESsage:NAV:FCDegradation:STATe.....	579
[:SOURCE<hw>]:BB:GNSS:SYSTEM:SBAS:MSAS:NMESsage:NAV:FCORrection:PERiod.....	581
[:SOURCE<hw>]:BB:GNSS:SYSTEM:SBAS:MSAS:NMESsage:NAV:FCORrection:STATe.....	579
[:SOURCE<hw>]:BB:GNSS:SYSTEM:SBAS:MSAS:NMESsage:NAV:IGRid:PERiod.....	581
[:SOURCE<hw>]:BB:GNSS:SYSTEM:SBAS:MSAS:NMESsage:NAV:IGRid:STATe.....	580
[:SOURCE<hw>]:BB:GNSS:SYSTEM:SBAS:MSAS:NMESsage:NAV:LTCorrection:PERiod.....	582
[:SOURCE<hw>]:BB:GNSS:SYSTEM:SBAS:MSAS:NMESsage:NAV:LTCorrection:STATe.....	580
[:SOURCE<hw>]:BB:GNSS:SYSTEM:SBAS:MSAS:NMESsage:NAV:PRN<ch>:STATe.....	578
[:SOURCE<hw>]:BB:GNSS:SYSTEM:SBAS:MSAS:NMESsage:NAV:PRNMask:PERiod.....	582
[:SOURCE<hw>]:BB:GNSS:SYSTEM:SBAS:MSAS:NMESsage:NAV:PRNMask:STATe.....	580

[:SOURCE<hw>]:BB:GNSS:SYSTEM:SBAS:MSAS:NMESSage:NAV:RINex:PERiod.....	582
[:SOURCE<hw>]:BB:GNSS:SYSTEM:SBAS:MSAS:NMESSage:NAV:RINex:STATe.....	580
[:SOURCE<hw>]:BB:GNSS:SYSTEM:SBAS:MSAS:NMESSage:NAV:SERVice:PERiod.....	582
[:SOURCE<hw>]:BB:GNSS:SYSTEM:SBAS:MSAS:NMESSage:NAV:SERVice:STATe.....	580
[:SOURCE<hw>]:BB:GNSS:SYSTEM:SBAS:MSAS:NMESSage:NAV:UTCoffset:PERiod.....	582
[:SOURCE<hw>]:BB:GNSS:SYSTEM:SBAS:MSAS:NMESSage:NAV:UTCoffset:STATe?.....	580
[:SOURCE<hw>]:BB:GNSS:SYSTEM:SBAS:MSAS[:STATe].....	364
[:SOURCE<hw>]:BB:GNSS:SYSTEM:SBAS:SIGNal:L1Band:CA[:STATe].....	365
[:SOURCE<hw>]:BB:GNSS:SYSTEM:SBAS:SIGNal:L5Band:EL5S[:STATe].....	365
[:SOURCE<hw>]:BB:GNSS:SYSTEM:SBAS:WAAS:NMESSage:NAV:ALManac:PERiod.....	582
[:SOURCE<hw>]:BB:GNSS:SYSTEM:SBAS:WAAS:NMESSage:NAV:ALManac:STATe.....	580
[:SOURCE<hw>]:BB:GNSS:SYSTEM:SBAS:WAAS:NMESSage:NAV:CECovariance:PERiod.....	582
[:SOURCE<hw>]:BB:GNSS:SYSTEM:SBAS:WAAS:NMESSage:NAV:CECovariance:STATe.....	580
[:SOURCE<hw>]:BB:GNSS:SYSTEM:SBAS:WAAS:NMESSage:NAV:DFACTor:PERiod.....	582
[:SOURCE<hw>]:BB:GNSS:SYSTEM:SBAS:WAAS:NMESSage:NAV:DFACTor:STATe.....	580
[:SOURCE<hw>]:BB:GNSS:SYSTEM:SBAS:WAAS:NMESSage:NAV:FCDegradation:PERiod.....	582
[:SOURCE<hw>]:BB:GNSS:SYSTEM:SBAS:WAAS:NMESSage:NAV:FCDegradation:STATe.....	580
[:SOURCE<hw>]:BB:GNSS:SYSTEM:SBAS:WAAS:NMESSage:NAV:FCORrection:PERiod.....	582
[:SOURCE<hw>]:BB:GNSS:SYSTEM:SBAS:WAAS:NMESSage:NAV:FCORrection:STATe.....	580
[:SOURCE<hw>]:BB:GNSS:SYSTEM:SBAS:WAAS:NMESSage:NAV:IGRID:PERiod.....	582
[:SOURCE<hw>]:BB:GNSS:SYSTEM:SBAS:WAAS:NMESSage:NAV:IGRID:STATe.....	580
[:SOURCE<hw>]:BB:GNSS:SYSTEM:SBAS:WAAS:NMESSage:NAV:LTCorrection:PERiod.....	582
[:SOURCE<hw>]:BB:GNSS:SYSTEM:SBAS:WAAS:NMESSage:NAV:LTCorrection:STATe.....	580
[:SOURCE<hw>]:BB:GNSS:SYSTEM:SBAS:WAAS:NMESSage:NAV:PRN<ch>:STATe.....	578
[:SOURCE<hw>]:BB:GNSS:SYSTEM:SBAS:WAAS:NMESSage:NAV:PRNMask:PERiod.....	582
[:SOURCE<hw>]:BB:GNSS:SYSTEM:SBAS:WAAS:NMESSage:NAV:PRNMask:STATe.....	580
[:SOURCE<hw>]:BB:GNSS:SYSTEM:SBAS:WAAS:NMESSage:NAV:RINex:PERiod.....	582
[:SOURCE<hw>]:BB:GNSS:SYSTEM:SBAS:WAAS:NMESSage:NAV:RINex:STATe.....	580
[:SOURCE<hw>]:BB:GNSS:SYSTEM:SBAS:WAAS:NMESSage:NAV:SERVice:PERiod.....	582
[:SOURCE<hw>]:BB:GNSS:SYSTEM:SBAS:WAAS:NMESSage:NAV:SERVice:STATe.....	580
[:SOURCE<hw>]:BB:GNSS:SYSTEM:SBAS:WAAS:NMESSage:NAV:UTCoffset:PERiod.....	582
[:SOURCE<hw>]:BB:GNSS:SYSTEM:SBAS:WAAS:NMESSage:NAV:UTCoffset:STATe?.....	580
[:SOURCE<hw>]:BB:GNSS:SYSTEM:SBAS:WAAS[:STATe].....	364
[:SOURCE<hw>]:BB:GNSS:SYSTEM:SBAS[:STATe]?.....	364
[:SOURCE<hw>]:BB:GNSS:TIME:CONVersion:BEIDou:UTC:AONE.....	379
[:SOURCE<hw>]:BB:GNSS:TIME:CONVersion:BEIDou:UTC:AONE:UNSCaled.....	379
[:SOURCE<hw>]:BB:GNSS:TIME:CONVersion:BEIDou:UTC:AZERo.....	378
[:SOURCE<hw>]:BB:GNSS:TIME:CONVersion:BEIDou:UTC:AZERo:UNSCaled.....	378
[:SOURCE<hw>]:BB:GNSS:TIME:CONVersion:BEIDou:UTC:IOFFset?.....	378
[:SOURCE<hw>]:BB:GNSS:TIME:CONVersion:BEIDou:UTC:TOT.....	377
[:SOURCE<hw>]:BB:GNSS:TIME:CONVersion:BEIDou:UTC:TOT:UNSCaled.....	377
[:SOURCE<hw>]:BB:GNSS:TIME:CONVersion:BEIDou:UTC:WNOT.....	376
[:SOURCE<hw>]:BB:GNSS:TIME:CONVersion:GALileo:UTC:AONE.....	379
[:SOURCE<hw>]:BB:GNSS:TIME:CONVersion:GALileo:UTC:AONE:UNSCaled.....	379
[:SOURCE<hw>]:BB:GNSS:TIME:CONVersion:GALileo:UTC:AZERo.....	379
[:SOURCE<hw>]:BB:GNSS:TIME:CONVersion:GALileo:UTC:AZERo:UNSCaled.....	379
[:SOURCE<hw>]:BB:GNSS:TIME:CONVersion:GALileo:UTC:IOFFset?.....	378
[:SOURCE<hw>]:BB:GNSS:TIME:CONVersion:GALileo:UTC:TOT.....	377
[:SOURCE<hw>]:BB:GNSS:TIME:CONVersion:GALileo:UTC:TOT:UNSCaled.....	377
[:SOURCE<hw>]:BB:GNSS:TIME:CONVersion:GALileo:UTC:WNOT.....	376

[:SOURCE<hw>]:BB:GNSS:TIME:CONVersion:GLONass:UTC:AONE.....	380
[:SOURCE<hw>]:BB:GNSS:TIME:CONVersion:GLONass:UTC:AONE:UNSCaled.....	379
[:SOURCE<hw>]:BB:GNSS:TIME:CONVersion:GLONass:UTC:AZERo.....	379
[:SOURCE<hw>]:BB:GNSS:TIME:CONVersion:GLONass:UTC:AZERo:UNSCaled.....	379
[:SOURCE<hw>]:BB:GNSS:TIME:CONVersion:GLONass:UTC:TOT.....	377
[:SOURCE<hw>]:BB:GNSS:TIME:CONVersion:GLONass:UTC:TOT:UNSCaled.....	377
[:SOURCE<hw>]:BB:GNSS:TIME:CONVersion:GLONass:UTC:WNOT.....	376
[:SOURCE<hw>]:BB:GNSS:TIME:CONVersion:GLONass:UTCSu:AONE.....	380
[:SOURCE<hw>]:BB:GNSS:TIME:CONVersion:GLONass:UTCSu:AONE:UNSCaled.....	380
[:SOURCE<hw>]:BB:GNSS:TIME:CONVersion:GLONass:UTCSu:AZERo.....	379
[:SOURCE<hw>]:BB:GNSS:TIME:CONVersion:GLONass:UTCSu:AZERo:UNSCaled.....	379
[:SOURCE<hw>]:BB:GNSS:TIME:CONVersion:GLONass:UTCSu:IOFFset?.....	378
[:SOURCE<hw>]:BB:GNSS:TIME:CONVersion:GLONass:UTCSu:TOT.....	377
[:SOURCE<hw>]:BB:GNSS:TIME:CONVersion:GLONass:UTCSu:TOT:UNSCaled.....	377
[:SOURCE<hw>]:BB:GNSS:TIME:CONVersion:GLONass:UTCSu:WNOT.....	376
[:SOURCE<hw>]:BB:GNSS:TIME:CONVersion:GPS:UTC:AONE.....	380
[:SOURCE<hw>]:BB:GNSS:TIME:CONVersion:GPS:UTC:AONE:UNSCaled.....	380
[:SOURCE<hw>]:BB:GNSS:TIME:CONVersion:GPS:UTC:AZERo.....	379
[:SOURCE<hw>]:BB:GNSS:TIME:CONVersion:GPS:UTC:AZERo:UNSCaled.....	379
[:SOURCE<hw>]:BB:GNSS:TIME:CONVersion:GPS:UTC:IOFFset?.....	378
[:SOURCE<hw>]:BB:GNSS:TIME:CONVersion:GPS:UTC:TOT.....	377
[:SOURCE<hw>]:BB:GNSS:TIME:CONVersion:GPS:UTC:TOT:UNSCaled.....	377
[:SOURCE<hw>]:BB:GNSS:TIME:CONVersion:GPS:UTC:WNOT.....	376
[:SOURCE<hw>]:BB:GNSS:TIME:CONVersion:LEAP:AUTO.....	372
[:SOURCE<hw>]:BB:GNSS:TIME:CONVersion:LEAP:DATE.....	373
[:SOURCE<hw>]:BB:GNSS:TIME:CONVersion:LEAP:SEConds:AFTer.....	373
[:SOURCE<hw>]:BB:GNSS:TIME:CONVersion:LEAP:SEConds:BEFore.....	373
[:SOURCE<hw>]:BB:GNSS:TIME:CONVersion:NAVic:UTC:AONE.....	379
[:SOURCE<hw>]:BB:GNSS:TIME:CONVersion:NAVic:UTC:AONE:UNSCaled.....	379
[:SOURCE<hw>]:BB:GNSS:TIME:CONVersion:NAVic:UTC:AZERo.....	378
[:SOURCE<hw>]:BB:GNSS:TIME:CONVersion:NAVic:UTC:AZERo:UNSCaled.....	378
[:SOURCE<hw>]:BB:GNSS:TIME:CONVersion:NAVic:UTC:IOFFset?.....	378
[:SOURCE<hw>]:BB:GNSS:TIME:CONVersion:NAVic:UTC:TOT.....	377
[:SOURCE<hw>]:BB:GNSS:TIME:CONVersion:NAVic:UTC:TOT:UNSCaled.....	377
[:SOURCE<hw>]:BB:GNSS:TIME:CONVersion:NAVic:UTC:WNOT.....	376
[:SOURCE<hw>]:BB:GNSS:TIME:CONVersion:QZSS:UTC:AONE.....	379
[:SOURCE<hw>]:BB:GNSS:TIME:CONVersion:QZSS:UTC:AONE:UNSCaled.....	379
[:SOURCE<hw>]:BB:GNSS:TIME:CONVersion:QZSS:UTC:AZERo.....	378
[:SOURCE<hw>]:BB:GNSS:TIME:CONVersion:QZSS:UTC:AZERo:UNSCaled.....	378
[:SOURCE<hw>]:BB:GNSS:TIME:CONVersion:QZSS:UTC:IOFFset?.....	378
[:SOURCE<hw>]:BB:GNSS:TIME:CONVersion:QZSS:UTC:TOT.....	377
[:SOURCE<hw>]:BB:GNSS:TIME:CONVersion:QZSS:UTC:TOT:UNSCaled.....	377
[:SOURCE<hw>]:BB:GNSS:TIME:CONVersion:QZSS:UTC:WNOT.....	376
[:SOURCE<hw>]:BB:GNSS:TIME:CONVersion:SBAS:EGNOS:UTC:AONE.....	379
[:SOURCE<hw>]:BB:GNSS:TIME:CONVersion:SBAS:EGNOS:UTC:AONE:UNSCaled.....	379
[:SOURCE<hw>]:BB:GNSS:TIME:CONVersion:SBAS:EGNOS:UTC:AZERo.....	378
[:SOURCE<hw>]:BB:GNSS:TIME:CONVersion:SBAS:EGNOS:UTC:AZERo:UNSCaled.....	378
[:SOURCE<hw>]:BB:GNSS:TIME:CONVersion:SBAS:EGNOS:UTC:IOFFset?.....	378
[:SOURCE<hw>]:BB:GNSS:TIME:CONVersion:SBAS:EGNOS:UTC:TOT.....	377
[:SOURCE<hw>]:BB:GNSS:TIME:CONVersion:SBAS:EGNOS:UTC:TOT:UNSCaled.....	377

[:SOURCE<hw>]:BB:GNSS:TIME:CONVersion:SBAS:EGNOS:UTC:WNOT.....	376
[:SOURCE<hw>]:BB:GNSS:TIME:CONVersion:SBAS:GAGAN:UTC:AONE.....	379
[:SOURCE<hw>]:BB:GNSS:TIME:CONVersion:SBAS:GAGAN:UTC:AONE:UNSCaled.....	379
[:SOURCE<hw>]:BB:GNSS:TIME:CONVersion:SBAS:GAGAN:UTC:AZERo.....	378
[:SOURCE<hw>]:BB:GNSS:TIME:CONVersion:SBAS:GAGAN:UTC:AZERo:UNSCaled.....	378
[:SOURCE<hw>]:BB:GNSS:TIME:CONVersion:SBAS:GAGAN:UTC:IOFFset?.....	378
[:SOURCE<hw>]:BB:GNSS:TIME:CONVersion:SBAS:GAGAN:UTC:TOT.....	377
[:SOURCE<hw>]:BB:GNSS:TIME:CONVersion:SBAS:GAGAN:UTC:TOT:UNSCaled.....	377
[:SOURCE<hw>]:BB:GNSS:TIME:CONVersion:SBAS:GAGAN:UTC:WNOT.....	376
[:SOURCE<hw>]:BB:GNSS:TIME:CONVersion:SBAS:MSAS:UTC:AONE.....	379
[:SOURCE<hw>]:BB:GNSS:TIME:CONVersion:SBAS:MSAS:UTC:AONE:UNSCaled.....	379
[:SOURCE<hw>]:BB:GNSS:TIME:CONVersion:SBAS:MSAS:UTC:AZERo.....	378
[:SOURCE<hw>]:BB:GNSS:TIME:CONVersion:SBAS:MSAS:UTC:AZERo:UNSCaled.....	378
[:SOURCE<hw>]:BB:GNSS:TIME:CONVersion:SBAS:MSAS:UTC:IOFFset?.....	378
[:SOURCE<hw>]:BB:GNSS:TIME:CONVersion:SBAS:MSAS:UTC:TOT.....	377
[:SOURCE<hw>]:BB:GNSS:TIME:CONVersion:SBAS:MSAS:UTC:TOT:UNSCaled.....	377
[:SOURCE<hw>]:BB:GNSS:TIME:CONVersion:SBAS:MSAS:UTC:WNOT.....	376
[:SOURCE<hw>]:BB:GNSS:TIME:CONVersion:SBAS:WAAS:UTC:AONE.....	379
[:SOURCE<hw>]:BB:GNSS:TIME:CONVersion:SBAS:WAAS:UTC:AONE:UNSCaled.....	379
[:SOURCE<hw>]:BB:GNSS:TIME:CONVersion:SBAS:WAAS:UTC:AZERo.....	378
[:SOURCE<hw>]:BB:GNSS:TIME:CONVersion:SBAS:WAAS:UTC:AZERo:UNSCaled.....	378
[:SOURCE<hw>]:BB:GNSS:TIME:CONVersion:SBAS:WAAS:UTC:IOFFset?.....	378
[:SOURCE<hw>]:BB:GNSS:TIME:CONVersion:SBAS:WAAS:UTC:TOT.....	377
[:SOURCE<hw>]:BB:GNSS:TIME:CONVersion:SBAS:WAAS:UTC:TOT:UNSCaled.....	377
[:SOURCE<hw>]:BB:GNSS:TIME:CONVersion:SBAS:WAAS:UTC:WNOT.....	376
[:SOURCE<hw>]:BB:GNSS:TIME:CONVersion:UTCSu:UTC:AONE.....	380
[:SOURCE<hw>]:BB:GNSS:TIME:CONVersion:UTCSu:UTC:AONE:UNSCaled.....	380
[:SOURCE<hw>]:BB:GNSS:TIME:CONVersion:UTCSu:UTC:AZERo.....	379
[:SOURCE<hw>]:BB:GNSS:TIME:CONVersion:UTCSu:UTC:AZERo:UNSCaled.....	379
[:SOURCE<hw>]:BB:GNSS:TIME:CONVersion:UTCSu:UTC:DATE?.....	376
[:SOURCE<hw>]:BB:GNSS:TIME:CONVersion:UTCSu:UTC:IOFFset?.....	378
[:SOURCE<hw>]:BB:GNSS:TIME:CONVersion:UTCSu:UTC:TOT.....	377
[:SOURCE<hw>]:BB:GNSS:TIME:CONVersion:UTCSu:UTC:TOT:UNSCaled.....	377
[:SOURCE<hw>]:BB:GNSS:TIME:CONVersion:UTCSu:UTC:WNOT.....	376
[:SOURCE<hw>]:BB:GNSS:TIME:START:BEIDou:OFFSet?.....	375
[:SOURCE<hw>]:BB:GNSS:TIME:START:BEIDou:TOWeek?.....	375
[:SOURCE<hw>]:BB:GNSS:TIME:START:BEIDou:WNUMBER?.....	374
[:SOURCE<hw>]:BB:GNSS:TIME:START:DATE.....	370
[:SOURCE<hw>]:BB:GNSS:TIME:START:GALileo:OFFSet?.....	375
[:SOURCE<hw>]:BB:GNSS:TIME:START:GALileo:TOWeek?.....	375
[:SOURCE<hw>]:BB:GNSS:TIME:START:GALileo:WNUMBER?.....	374
[:SOURCE<hw>]:BB:GNSS:TIME:START:GLONass:DATE?.....	374
[:SOURCE<hw>]:BB:GNSS:TIME:START:GLONass:OFFSet?.....	375
[:SOURCE<hw>]:BB:GNSS:TIME:START:GLONass:TIME?.....	374
[:SOURCE<hw>]:BB:GNSS:TIME:START:GPS:OFFSet?.....	375
[:SOURCE<hw>]:BB:GNSS:TIME:START:GPS:TOWeek?.....	375
[:SOURCE<hw>]:BB:GNSS:TIME:START:GPS:WNUMBER?.....	374
[:SOURCE<hw>]:BB:GNSS:TIME:START:NAVic:OFFSet?.....	375
[:SOURCE<hw>]:BB:GNSS:TIME:START:NAVic:TOWeek?.....	375
[:SOURCE<hw>]:BB:GNSS:TIME:START:NAVic:WNUMBER?.....	374

[:SOURCE<hw>]:BB:GNSS:TIME:START:QZSS:OFFSet?.....	375
[:SOURCE<hw>]:BB:GNSS:TIME:START:QZSS:TOWeek?.....	375
[:SOURCE<hw>]:BB:GNSS:TIME:START:QZSS:WNUMber?.....	374
[:SOURCE<hw>]:BB:GNSS:TIME:START:SBAS:EGNOS:OFFSet?.....	375
[:SOURCE<hw>]:BB:GNSS:TIME:START:SBAS:EGNOS:TOWeek?.....	375
[:SOURCE<hw>]:BB:GNSS:TIME:START:SBAS:EGNOS:WNUMber?.....	374
[:SOURCE<hw>]:BB:GNSS:TIME:START:SBAS:GAGAN:OFFSet?.....	375
[:SOURCE<hw>]:BB:GNSS:TIME:START:SBAS:GAGAN:TOWeek?.....	375
[:SOURCE<hw>]:BB:GNSS:TIME:START:SBAS:GAGAN:WNUMber?.....	374
[:SOURCE<hw>]:BB:GNSS:TIME:START:SBAS:MSAS:OFFSet?.....	375
[:SOURCE<hw>]:BB:GNSS:TIME:START:SBAS:MSAS:TOWeek?.....	375
[:SOURCE<hw>]:BB:GNSS:TIME:START:SBAS:MSAS:WNUMber?.....	374
[:SOURCE<hw>]:BB:GNSS:TIME:START:SBAS:WAAS:TOWeek?.....	375
[:SOURCE<hw>]:BB:GNSS:TIME:START:SBAS:WAAS:WNUMber?.....	374
[:SOURCE<hw>]:BB:GNSS:TIME:START:SCTime.....	371
[:SOURCE<hw>]:BB:GNSS:TIME:START:TBASis.....	371
[:SOURCE<hw>]:BB:GNSS:TIME:START:TIME.....	371
[:SOURCE<hw>]:BB:GNSS:TIME:START:TOWeek.....	372
[:SOURCE<hw>]:BB:GNSS:TIME:START:UTC:DATE?.....	374
[:SOURCE<hw>]:BB:GNSS:TIME:START:UTC:OFFSet?.....	375
[:SOURCE<hw>]:BB:GNSS:TIME:START:UTC:TIME?.....	374
[:SOURCE<hw>]:BB:GNSS:TIME:START:WNUMber.....	372
[:SOURCE<hw>]:BB:GNSS:TMODe.....	358
[:SOURCE<hw>]:BB:GNSS:TRIGger:ARM:EXECute.....	643
[:SOURCE<hw>]:BB:GNSS:TRIGger:EXECute.....	643
[:SOURCE<hw>]:BB:GNSS:TRIGger:EXternal:SYNChronize:OUTPut.....	643
[:SOURCE<hw>]:BB:GNSS:TRIGger:OBASeband:DElay.....	644
[:SOURCE<hw>]:BB:GNSS:TRIGger:OBASeband:INHibit.....	644
[:SOURCE<hw>]:BB:GNSS:TRIGger:OUTPut<ch>:DElay.....	646
[:SOURCE<hw>]:BB:GNSS:TRIGger:OUTPut<ch>:HPPS:ADElay.....	647
[:SOURCE<hw>]:BB:GNSS:TRIGger:OUTPut<ch>:HPPS:STATe.....	647
[:SOURCE<hw>]:BB:GNSS:TRIGger:OUTPut<ch>:MODE.....	646
[:SOURCE<hw>]:BB:GNSS:TRIGger:OUTPut<ch>:OFFTime.....	646
[:SOURCE<hw>]:BB:GNSS:TRIGger:OUTPut<ch>:ONTime.....	646
[:SOURCE<hw>]:BB:GNSS:TRIGger:OUTPut<ch>:PATtern.....	647
[:SOURCE<hw>]:BB:GNSS:TRIGger:OUTPut<ch>:PULSe:DIVider.....	647
[:SOURCE<hw>]:BB:GNSS:TRIGger:OUTPut<ch>:PULSe:FREquency?.....	648
[:SOURCE<hw>]:BB:GNSS:TRIGger:OUTPut<ch>:PULSe:WIDTh.....	648
[:SOURCE<hw>]:BB:GNSS:TRIGger:RMODe?.....	641
[:SOURCE<hw>]:BB:GNSS:TRIGger:SLENgth.....	643
[:SOURCE<hw>]:BB:GNSS:TRIGger:SOURce.....	640
[:SOURCE<hw>]:BB:GNSS:TRIGger:TIME:DATE.....	641
[:SOURCE<hw>]:BB:GNSS:TRIGger:TIME:TIME.....	642
[:SOURCE<hw>]:BB:GNSS:TRIGger:TIME[:STATe].....	642
[:SOURCE<hw>]:BB:GNSS:TRIGger[:EXternal]:DElay.....	644
[:SOURCE<hw>]:BB:GNSS:TRIGger[:EXternal]:INHibit.....	645
[:SOURCE<hw>]:BB:GNSS:VEHicle:CATalog:PREDEfined?.....	389
[:SOURCE<hw>]:BB:GNSS:VEHicle:CATalog:USER?.....	389
[:SOURCE<hw>]:BB:GNSS:VEHicle:COUnT.....	639
[:SOURCE<hw>]:BB:GNSS[:TRIGger]:SEqueNce.....	640

Index

Symbols

- *.xtd 656
- *.xvd 662
- 3GPP FDD 2020 test scenarios
 - A-GNSS 676
- 3GPP FDD test scenarios
 - A-GNSS 672
- 3GPP2 test scenarios
 - A-GNSS 673
- A**
- A-GNSS
 - 3GPP 2020 FDD test scenarios 676
 - 3GPP FDD test scenarios 672
 - 3GPP2 test scenarios 673
 - EUTRA/LTE 2020 test scenarios 677
 - EUTRA/LTE test scenarios 673
 - GSM test scenarios 672
- Additive noise
 - About 192
 - Settings 192
 - To add noise 193
 - To shift noise 194
- Advanced GNSS
 - Change composition of GNSS streams 279
 - Change number of GNSS streams 278
 - Enable GNSS advanced mode 269
 - How to 268
 - Lock GNSS streams 278
 - Resolve signal routing conflicts 281
 - Set up a multi-antenna scenario 277
 - Set up a multi-vehicle scenario 275
 - Set up dual-frequency single-GNSS scenario 271
 - Set up multi-frequency GNSS scenarios 270
 - Set up triple-frequency multi-GNSS scenario 273
 - Set up triple-frequency single-GNSS scenario 272
 - To add CW interferer 195
 - To add noise 195
- Advanced GNSS scenarios 267
- Advanced mode 267
 - Output streams settings 285
 - Related settings 282
- Alert
 - Fast correction 258
- Algorithm
 - Prediction 320
- alpha_0 to alpha_3 205
- Altitude 56, 148, 159, 324
- Antenna
 - 3D view 128, 162
 - Active 128, 162
 - Creating 114
 - Modifying 114
 - Pattern 127, 161
 - Saving changes 132
 - Select 128, 162
- Antenna pattern
 - Loading 110
 - OTA measurements 110
 - View type 132
- Visualizing 115
- Zooming 114
- Antenna pattern graph
 - Attenuation 132
 - Azimuth 132
 - Elevation 132
 - Phase 132
 - Resolution 132
 - Settings 127, 161
- Antenna position
 - Bank 129, 163
 - Delta X, Y, Z 129, 162
 - Elevation 129, 163
 - Heading 129, 163
- Antenna profile
 - see antenna pattern 110
- Application cards 15
- Application notes 15
- Arm 340
- Armed_Auto 338
- Armed_Retrigger 338
- Assistance data
 - Date 306
 - Duration 307
 - Navigation data format 302
 - Resolution 307
 - SV state 305
 - Synchronize 302
 - Time 306
 - Time basis 306
 - Time of week 307
 - Week number 306
- Assistance data generation 299
 - General settings 301
 - Generating assistance data 299
 - Settings 300
 - Space vehicle settings 305
 - Time of assistance data settings 305
- Assistance mode 301
- Assisted GNSS
 - Test scenarios 671
- Assisted GNSS 2020
 - Test scenarios 676
- Attitude view 36
 - How to 117
- Auto 338
- B**
- Bank 67
- beta_0 to beta_3 205
- Body mask
 - Effects 108
 - File select 128, 162
- Broadcast rate
 - SBAS message 239
 - SBAS message type 264
- Brochures 15
- Buffer time, additional
 - Compensating HIL command jitter 318

C

Calibration certificate	15
Carrier frequencies	70
Change an antenna pattern	
How to	118
Channel budget	
Hardware resources	683
Instrument setups	685
Clock	
Mode	347
Source	347
Clock drift corrections	259
Clock-Ephemeris	
See C-E	261
Command delay	
Compensating jitter	318
Command jitter (HLL)	
Compensating	318
Definition	318
Common trigger settings	338
Compensation	
Latency	316
Conventions	
SCPI commands	353
Coordinate	
Definition in a *.xtd file	657
First edge	136
Coupled trigger settings	338
CW interferer	
About	192
Settings	192
To add a CW interferer	195

D

Data acquisition	
See Data logging	289
Data download	
See Data logging	289
Data logging	
Application	289
File content	289
File format	289
File names	289
Logged parameters	289
Postprocessing	289
Data sheets	15
Data signal	
Disable	90
Date	48
Default settings	
GNSS	33
Degradation factor	
c_covariance	266
Degradation factors	
C_ltc_v0, I_ltc_v0	265
C_ltc_v1, C_ltc_Isb, I_ltc_v1	265
Degradation for En-route through LNAV	266
Degradation of ionospheric corrections	
RSS_iono, C_iono_step, C_geo_v, I_iono	266
Delay	
Marker	345
Trigger	342
Delta x,y,z	
Long-term correction	259

Derivatives	
Long-term correction	259
Direction	136
Display an antenna pattern	
How to	114
Display type	37
Do not use	
Fast correction	258
Documentation overview	13
DUT	
Test mode	34

E

ECEF WGS84	
Reference frame	56, 63, 159, 324
Elevation	67
Enable	
BeiDou	70
Galileo	70
GLONASS	70
GPS	70
NavIC	70
QZSS	70
SBAS	70
EUTRA/LTE 2020 test scenarios	
A-GNSS	677
EUTRA/LTE test scenarios	
A-GNSS	673
External trigger	342
External trigger delay	342

F

Fast correction degradation	
RSS_UDRE	266
Fast correction degradation factor	260
Fast correction degradation factors	265
File	
Body mask	128, 162
Roadside planes	140
Vertical obstacles	135
Full obscuration	
How to	125
Reference	145
Width	145

G

General workflow	350
Generate	
Acquisition file	303
Almanac file	302
Navigation file	303
RINEX file	303
GEO navigation message degradation	
I_geo, C_geo_Isb, C_geo_v	266
Getting started	14
GNSS	
Active	70
Augmentation	70
Enable	70
Global	70
Regional	70
GNSS overview	19
BeiDou, COMPASS	22
Galileo	21

- GLONASS 21
- GPS 20
- NavIC 23
- QZSS 22
- Greenwich mean time 48
- Ground reflection
 - How to 125
- GSM test scenarios
 - A-GNSS 672
- H**
- Handover
 - Criteria 78
- Handover satellites
 - Criteria 75
- HDOP 42
- Heading 67
- Help 14
- High-precision PPS
 - Additional delay 346
 - Generate 346
- HIL commands
 - Time resolution 328
 - Unstable update rate 318
 - Update rate 328
- How to
 - Change composition of GNSS streams 279
 - Change number of GNSS streams 278
 - Change OSNMA time and position 170
 - Check for non-OSNMA satellites 170
 - Enable GNSS advanced mode 269
 - Export a predefined waypoint file 60
 - Generate OSNMA public keys 169
 - Install OSMA keys on GNSS receivers 170
 - Load OSNMA scenario 167, 178
 - Load waypoint file 59
 - Lock GNSS streams 278
 - Monitor receiver movement 60
 - Play waypoint file 59
 - Reset OSNMA GNSS receiver 169
 - Resolve signal routing conflicts 281
 - Set up a multi-antenna scenario 277
 - Set up a multi-vehicle scenario 275
 - Set up dual-frequency single-GNSS scenario 271
 - Set up multi-frequency GNSS scenarios 270
 - Set up triple-frequency multi-GNSS scenario 273
 - Set up triple-frequency single-GNSS scenario 272
- HW channels 36
- I**
- ifc
 - Fast correction degradation factor 260
- Indicator
 - C-E covariance matrix 261
 - Fast correction degradation factor 260
- Infinite width 143
- Installation 11
- Instrument help 14
- Instrument security procedures 14
- IOD
 - Fast correction 265
 - Ionospheric mask 264
 - PRN mask 265
 - Service 265
- IODE
 - Long-term correction 259
- IODP
 - C-E covariance matrix 261
- Ionospheric grid
 - Parameters 207
- Ionospheric model 205
- K**
- Key features 11
- L**
- Latency
 - Calibration 316
- Latitude 56, 159, 324
- LEO
 - Use earth tangent mask 79
- LNAV/VNAV, LP, LPV
 - C_er 266
- Load an antenna pattern
 - How to 114
- Location
 - Receiver 55, 158, 322
- Long-term correction degradation
 - Factors 265
 - GEO navigation message 266
 - RSS_UDRE 266
 - Velocity code=0 265
 - Velocity code=1 265
- Longitude 56, 159, 324
- M**
- Map
 - Alignment 137
- Map view 36
- Marker
 - Generate High-precision PPS 346
- Marker delay 345
- Matched-spectrum GNSS interferer 187
- Matched-spectrum interferer
 - Settings 188
- Material
 - Permittivity 137, 142
 - Power loss 137, 142
 - Property 136, 141, 147
- Maximum fast correction update interval 260
- Measured external clock 347
- Model
 - Physical 135, 140
- Modify an antenna pattern
 - How to 120
- MOPS
 - Parameters 207
- Motion
 - Simulation 107
- Movement
 - Description 62
 - Duration 63
 - File, readout mode 63
- Moving receiver
 - Export a predefined waypoint file 60
 - Load waypoint file 59
 - Monitor receiver movement 60
 - Play waypoint file 59

- MT 1 254, 258
- MT 2 255
- MT 3 255
- MT 4 255
- MT 5 255
- MT 7 259
- MT 24 258
- MT 25 258
- MT 28 260
- Multipath scenario
 - How to 122
- Multipath, static
 - How to 122
- N**
- Navigation data
 - Logging 289
- Navigation data format
 - Assistance data 302
- Navigation message
 - Components 90
- NeQuick
 - Parameters 206
- Number of
 - Regions 265
 - Service messages 265
- O**
- Obscuration
 - Distance to receiver 148
 - Earth surface 79, 81
 - Height 148
- Obstacle
 - File 135
 - Height 136, 141
 - Length 136
 - Material 136, 141
- Open source acknowledgment (OSA) 15
- Orientation
 - Map 137
- OSNMA
 - About 164
 - About real-time signals 165
 - About test vectors 165
 - Additional data delay 176
 - CMAC AES key length 175
 - Common settings 172
 - Configuration 171
 - Configuration and settings 166
 - Configure realtime parameters 566
 - Configuring the GNSS receiver 168
 - Configuring the R&S SMW200A 167
 - Generating 164
 - Generating test vector signals 178
 - HF field 174
 - KS field 174
 - Load a scenario 448
 - MACLT 173
 - MF field 175
 - NPKT field 174
 - PID field 175
 - PKT duration step 1 178
 - PKT duration step 2 178
 - Public key transitions 177
 - Root key transitions 177
 - State 180
 - Status preemption 176
 - TESLA keys transition settings 176
 - TESLA step 1 177
 - TESLA step 2 177
 - Test phase ADKD4 176
 - Test setup 166
 - Time offset public key 178
 - Time offset root key 177
 - Transition mode 172
 - TS field 173
- OSNMA test vectors
 - Configuring the GNSS receiver 180
 - Configuring the R&S SMW200A 178
 - Related settings 180
- Output streams
 - Access 285
 - Settings 285
- P**
- Parametry Zemli
 - see PZ 56, 63, 159, 324
- PDOP 42
- Period
 - SBAS message 239
 - SBAS message type 264
- Pilot signal
 - Disable 90
- Pitch 67
- Planes
 - File 140
- Position
 - Reference receiver 141
- Position Format 56, 159, 324
- Power view 36
- PRC 258
- Predefined scenario
 - GNSS 34
- Prediction algorithm 320
- Priority code
 - Service message 265
- PRN mask 254, 255
- Property
 - Permittivity 136, 141, 147
 - Power loss 136, 141, 147
- PZ
 - Reference frame 56, 63, 159, 324
- R**
- Range-rate correction degradation
 - B_irc 265
- Real constellations
 - Broadcast data scenarios 680
 - Reference scenarios 680
- Receiver
 - Attitude 44
 - Environment configuration 132
 - Ground altitude 148
 - Number of antennas 54, 127
 - Position 42
 - Type 53
 - Velocity 42
- Receiver position
 - Offset to reference point 137

- Receiver tests signal
 - How to 351
- Receivers
 - Number of 283
- Reference
 - Power 75
- Reference frame
 - ECEF WGS84 56, 63, 159, 324
 - GLONASS 56, 63, 159, 324
 - GPS 56, 63, 159, 324
 - PZ 56, 63, 159, 324
 - Transformation formula 56, 63, 159, 324
- Reference scale 145
- Region
 - Coordinates 265
 - Shape 265
- Release notes 15
- Remote control
 - Programming examples 355
- Repetition interval 142
 - Align with trajectory 142, 145
- Repetition interval 145
- Repetition state 142, 145
- Repetition window 145
- Required options 17
- Retrigger 338
- Roadside planes
 - How to 124
- Roadsides planes
 - Alignment 141
 - Distance 141
- RTK 152
 - Antenna configuration 160
 - Mountpoint 155
 - Number of base stations 154
 - Position configuration 157
 - Protocol configuration 156
 - Settings 154
 - State 154
 - Sync to receiver position 157
- RTK protocol
 - Host IP 156
 - Password 157
 - Port 156
 - Protocol 156
 - User ID 156
- S**
- Safety instructions 15
- SAR
 - Configuring RLM and spare data 479
 - Mode 550
 - RLM data 551
 - Spare data 551
- Satellite
 - Elevation mask 81
 - Maximum number of channels 81, 288
 - Selection configuration 75
- Satellite constellation
 - Reference vehicle 285
- Save/Recall
 - GNSS 33
- SBAS
 - Activating 241
 - Activating SBAS 241
 - Applying SBAS corrections 243
 - Generating 241
 - Loading historical data 239
 - Mapping space vehicles 242
 - PRN assignments 239
 - PRN mapping 244
 - PRN mapping SBAS system 245
- SBAS message
 - Broadcast rate 239
 - Interval 239
 - Periodicity 239
 - Scheduling 239
- SBAS message type
 - Broadcast rate 264
 - Enabling 264
 - Interval 264
 - Periodicity 264
 - Scheduling 264
- Scale
 - Units 145
- Sea reflection
 - How to 125
- Security procedures 14
- Service manual 14
- Service message number 265
- Set to default
 - GNSS 33
- Sigma UDRE 258
- Signal dynamics
 - Acceleration, max 184
 - Carrier phase, initial 183
 - Jerk, max 184
 - Offset start time 183
 - Period of constant acceleration 184
 - Period of constant velocity 184
 - Profile repeated after 184
 - Profile type 182
 - Pseudorange, initial 182
 - Velocity 183
 - Velocity profile type 183
 - Velocity, initial 183, 184
- Signal generation status 339
- Simulating antenna pattern
 - How to 114
- Simulating body masks
 - How to 114, 115
- Simulation
 - Time 42
- Simulation of
 - Antenna pattern 108
 - Motion 107
- Simulation start time 48
- Single 338
- Sky view 36
- Specifications 15
- Spinning
 - Rate 67
- Spinning rate 67
- Standard settings
 - GNSS 33
- Start roll 67
- State
 - GNSS 33
- Streaming rate (HIL)
 - see update rate 328
- Surface
 - Conductivity 148
 - Permittivity 148

Power loss	148
Property	147
SV ID	
Healthy status	86
Include in the constellation	86
SV location	
Long-term correction	259
SV position errors	
Long-term correction	259
Synchronize	
Assistance data	302
Synchronizing	
Flight simulator	315
System latency	
Calibration	316
Querying	316
Reducing	320
System latency time	260
System time	48
T	
Tag	
waypointvector	657
Test mode	34
Aerospace applications	34
TTFF	34
Test scenarios	
Understanding scenario name	670
Time of Day	259
Time of week (TOW)	48
Time-based trigger	
Date	340
State	339
Time	340
Trajectory description	656
Trajectory view	36
Transformation	
Reference frame	56, 63, 159, 324
Trigger	
Synchronize output	341
Trigger delay	342
Trigger mode	338
Trigger signal duration	339
Trigger source	340
Tropospheric model	204
Tutorials	14
U	
UDRE	
Accuracy	258
Value	258
UDREI	258
Service message	265
Update rate	
HIL commands	328
Use antenna pattern for automotive	
How to	119
User manual	14
User time-out interval	
En-route through LANV Approach	260
En-route through LANV/VAN, LV, LP Approach	260
Fast correction degradation factor	260

V

Vehicle description	662
Vehicles	
Number of	283
Velocity	
Component description	657
Velocity magnitude	
Definition in a *.xtd file	657
Vertical obstacles	
Cutting	138
Highway	138
How to	124
Suburban area	138
Videos	15
View	
Type	142
View type	
Map view	138

W

Warning	
Not enough memory	661
Waypoint file too long	661
Waypoint	
Smooth movement	65
Waypoint format	
Parameter definition in a *.xtd file (waypointformat) .	657
Week number	48
WGS84	148
White papers	15

X

xtd file	
datavectorhastimestamp	657
Parameter and tags	657
timeresolution	657
veloc	657
waypointformat	657

Y

Yaw	67
-----------	----

Z

Zoom in/out	
How to, antenna graph	114