

R&S®ESW

Analog Modulation Analysis User Manual



1178366302
Version 12

ROHDE & SCHWARZ
Make ideas real



This manual describes the following R&S®ESW models:

- R&S®ESW8 (1328.4100K08)
- R&S®ESW8 (1328.4100K09)
- R&S®ESW26 (1328.4100K26)
- R&S®ESW26 (1328.4100K27)
- R&S®ESW44 (1328.4100K44)
- R&S®ESW44 (1328.4100K45)

The contents of this manual correspond to firmware version 3.20 and higher.

© 2025 Rohde & Schwarz

Muehldorfstr. 15, 81671 Muenchen, Germany

Phone: +49 89 41 29 - 0

Email: info@rohde-schwarz.com

Internet: www.rohde-schwarz.com

Subject to change – data without tolerance limits is not binding.

R&S® is a registered trademark of Rohde & Schwarz GmbH & Co. KG.

Trade names are trademarks of the owners.

1178.3663.02 | Version 12 | R&S®ESW

Throughout this manual, products from Rohde & Schwarz are indicated without the ® symbol , e.g. R&S®ESW is indicated as R&S ESW.

Contents

1	Preface.....	5
1.1	About this manual.....	5
1.2	Documentation overview.....	6
1.3	Conventions used in the documentation.....	8
2	Welcome to the Analog Modulation Analysis application.....	9
2.1	Starting AM/FM/PM Modulation Analysis.....	9
2.2	Understanding the display information.....	10
3	Measurements and result displays.....	13
4	Measurement basics.....	24
4.1	Demodulation process.....	24
4.2	Demodulation bandwidth.....	26
4.3	Sample rate and demodulation bandwidth.....	27
4.4	AF triggers.....	29
4.5	AF filters.....	29
4.6	Time domain zoom.....	29
4.7	Receiving data input and providing data output.....	31
5	Configuration.....	36
5.1	Configuration according to digital standards.....	36
5.2	Configuration overview.....	38
5.3	Data input and output.....	39
5.4	Amplitude.....	49
5.5	Frequency.....	52
5.6	Trigger configuration.....	53
5.7	Bandwidth settings.....	59
5.8	Sweep settings.....	60
5.9	Demodulation.....	62
5.10	Demodulation display.....	78
5.11	Automatic settings.....	78
6	Analysis.....	81
6.1	Trace configuration.....	81

6.2	Marker settings.....	82
6.3	Display lines and limit lines.....	83
7	How to perform measurements in the Analog Modulation Analysis application.....	84
7.1	How to export trace data and numerical results.....	85
8	Measurement example: demodulating an FM signal.....	86
9	Optimizing and troubleshooting the measurement.....	91
10	Remote commands for Analog Modulation Analysis.....	92
10.1	Introduction.....	92
10.2	Common suffixes.....	97
10.3	Application selection.....	97
10.4	Measurement configuration.....	101
10.5	Result display configuration.....	155
10.6	Measurement results.....	163
10.7	Analysis.....	174
10.8	Data import and export.....	176
10.9	Programming example.....	177
	Annex.....	180
A	Reference.....	180
A.1	Predefined standards and settings.....	180
A.2	Formats for returned values: ASCII format and binary format.....	182
A.3	Reference: ASCII file export format.....	183
A.4	I/Q data file format (iq-tar).....	183
	List of commands.....	192
	Index.....	197

1 Preface

1.1 About this manual

This Analog Modulation Analysis User Manual provides all the information **specific to the application**. All general instrument functions and settings common to all applications and operating modes are described in the main R&S ESW User Manual.

The main focus in this manual is on the measurement results and the tasks required to obtain them. The following topics are included:

- **Welcome to the Analog Modulation Analysis Application**
Introduction to and getting familiar with the application
- **Measurements and Result Displays**
Details on supported measurements and their result types
- **Measurement Basics**
Background information on basic terms and principles in the context of the measurement
- **Configuration + Analysis**
A concise description of all functions and settings available to configure measurements and analyze results with their corresponding remote control command
- **I/Q Data Import and Export**
Description of general functions to import and export raw I/Q (measurement) data
- **How to Perform Measurements in the Analog Modulation Analysis Application**
The basic procedure to perform each measurement and step-by-step instructions for more complex tasks or alternative methods
- **Measurement Examples**
Detailed measurement examples to guide you through typical measurement scenarios and allow you to try out the application immediately
- **Optimizing and Troubleshooting the Measurement**
Hints and tips on how to handle errors and optimize the measurement configuration
- **Remote Commands for Analog Modulation Analysis Measurements**
Remote commands required to configure and perform Analog Modulation Analysis measurements in a remote environment, sorted by tasks
(Commands required to set up the environment or to perform common tasks on the instrument are provided in the main R&S ESW User Manual)
Programming examples demonstrate the use of many commands and can usually be executed directly for test purposes
- **List of remote commands**
Alphabetical list of all remote commands described in the manual
- **Index**

1.2 Documentation overview

This section provides an overview of the R&S ESW user documentation. Unless specified otherwise, you find the documents at:

www.rohde-schwarz.com/manual/esw

1.2.1 Getting started manual

Introduces the R&S ESW and describes how to set up and start working with the product. Includes basic operations, typical measurement examples, and general information, e.g. safety instructions, etc.

A printed version is delivered with the instrument. A PDF version is available for download on the Internet.

1.2.2 User manuals and help

Separate user manuals are provided for the base unit and the firmware applications:

- Base unit manual
Contains the description of all instrument modes and functions. It also provides an introduction to remote control, a complete description of the remote control commands with programming examples, and information on maintenance, instrument interfaces and error messages. Includes the contents of the getting started manual.
- Firmware application manual
Contains the description of the specific functions of a firmware application, including remote control commands. Basic information on operating the R&S ESW is not included.

The contents of the user manuals are available as help in the R&S ESW. The help offers quick, context-sensitive access to the complete information for the base unit and the firmware applications.

All user manuals are also available for download or for immediate display on the Internet.

1.2.3 Service manual

Describes the performance test for checking the rated specifications, module replacement and repair, firmware update, troubleshooting and fault elimination, and contains mechanical drawings and spare part lists.

The service manual is available for registered users on the global Rohde & Schwarz information system (GLORIS):

<https://gloris.rohde-schwarz.com>

1.2.4 Instrument security procedures

Deals with security issues when working with the R&S ESW in secure areas. It is available for download on the internet.

1.2.5 Printed safety instructions

Provides safety information in many languages. The printed document is delivered with the product.

1.2.6 Specifications and brochures

The specifications document, also known as the data sheet, contains the technical specifications of the R&S ESW. It also lists the firmware applications and their order numbers, and optional accessories.

The brochure provides an overview of the instrument and deals with the specific characteristics.

See www.rohde-schwarz.com/brochure-datasheet/esw

1.2.7 Release notes and open source acknowledgment (OSA)

The release notes list new features, improvements and known issues of the current software version, and describe the software installation.

The software uses several valuable open source software packages. An open source acknowledgment document provides verbatim license texts of the used open source software.

See www.rohde-schwarz.com/firmware/esw

1.2.8 Application notes, application cards, white papers, etc.

These documents deal with special applications or background information on particular topics.

See www.rohde-schwarz.com/application/esw

1.2.9 Videos

Find various videos on Rohde & Schwarz products and test and measurement topics on YouTube: <https://www.youtube.com/@Rohde-Schwarz>

1.3 Conventions used in the documentation

1.3.1 Typographical conventions

The following text markers are used throughout this documentation:

Convention	Description
"Graphical user interface elements"	All names of graphical user interface elements on the screen, such as dialog boxes, menus, options, buttons, and softkeys are enclosed by quotation marks.
[Keys]	Key and knob names are enclosed by square brackets.
Filenames, commands, program code	Filenames, commands, coding samples and screen output are distinguished by their font.
<i>Input</i>	Input to be entered by the user is displayed in italics.
Links	Links that you can click are displayed in blue font.
"References"	References to other parts of the documentation are enclosed by quotation marks.

1.3.2 Conventions for procedure descriptions

When operating the instrument, several alternative methods may be available to perform the same task. In this case, the procedure using the touchscreen is described. Any elements that can be activated by touching can also be clicked using an additionally connected mouse. The alternative procedure using the keys on the instrument or the on-screen keyboard is only described if it deviates from the standard operating procedures.

The term "select" may refer to any of the described methods, i.e. using a finger on the touchscreen, a mouse pointer in the display, or a key on the instrument or on a keyboard.

1.3.3 Notes on screenshots

When describing the functions of the product, we use sample screenshots. These screenshots are meant to illustrate as many as possible of the provided functions and possible interdependencies between parameters. The shown values may not represent realistic usage scenarios.

The screenshots usually show a fully equipped product, that is: with all options installed. Thus, some functions shown in the screenshots may not be available in your particular product configuration.

2 Welcome to the Analog Modulation Analysis application

The Analog Modulation Analysis application converts the R&S ESW into an analog modulation analyzer for amplitude-, frequency- or phase-modulated signals. It measures not only characteristics of the useful modulation, but also factors such as residual FM or synchronous modulation.

The digital signal processing in the R&S ESW, used in the Spectrum application for digital IF filters, is also ideally suited for demodulating AM, FM, or PM signals.

The Analog Modulation Analysis application features:

- AM, FM, and PM demodulation, with various result displays:
 - Modulation signal versus time
 - Spectrum of the modulation signal (FFT)
 - RF signal power versus time
 - Spectrum of the RF signal
- Determining maximum, minimum and average or current values in parallel over a selected number of measurements
- Maximum accuracy and temperature stability due to sampling (digitization) already at the IF and digital down-conversion to the baseband (I/Q)
- Error-free AM to FM conversion and vice versa, without deviation errors, frequency response or frequency drift at DC coupling
- Relative demodulation, in relation to a user-defined or measured reference value

This user manual contains a description of the functionality that the application provides, including remote control operation.

All functions not discussed in this manual are the same as in the base unit and are described in the R&S ESW User Manual. The latest version is available for download at the product homepage <http://www.rohde-schwarz.com/product/esw>.

Installation

You can find detailed installation instructions in the R&S ESW Getting Started manual or in the Release Notes.

2.1 Starting AM/FM/PM Modulation Analysis

AM/FM/PM Modulation Analysis is a separate application on the R&S ESW.

To activate AM/FM/PM Modulation Analysis

1. Select [MODE].

A dialog box opens that contains all operating modes and applications currently available on your R&S ESW.

2. Select the "AM FM PM Analog Demod" item.



The R&S ESW opens a new channel for the application for analog modulation analysis.

The measurement is started immediately with the default settings. It can be configured in the analog modulation analysis [Configuration overview](#) dialog box, which is displayed when you select "Overview" from any menu.

Multiple Channels and Sequencer Function

When you activate an application, a new channel is created which determines the measurement settings for that application ("Channel"). The same application can be activated with different measurement settings by creating several "Channel"s for the same application.

The number of channels that can be configured at the same time depends on the available memory on the instrument.

Only one measurement can be performed at any time, namely the one in the currently active channel. However, to perform the configured measurements consecutively, a Sequencer function is provided.

If activated, the measurements configured in the currently defined "Channel"s are performed one after the other in the order of the tabs. The currently active measurement is indicated by a  symbol in the tab label.

The result displays of the individual channels are updated in the tabs (as well as the "MultiView") as the measurements are performed. Sequential operation itself is independent of the currently *displayed* tab.

For details on the Sequencer function, see the R&S ESW User Manual.

2.2 Understanding the display information

The following figure shows a measurement diagram during analog modulation analysis. All different information areas are labeled. They are explained in more detail in the following sections.



- 1 = Channel bar for firmware and measurement settings
- 2 = Window title bar with diagram-specific (trace) information
- 3 = Diagram area
- 4 = Diagram footer with diagram-specific information, depending on result display
- 5 = Instrument status bar with error messages and date/time display

Channel bar information

In the Analog Modulation Analysis application, the R&S ESW shows the following settings:

Table 2-1: Information displayed in the channel bar in the application for analog modulation analysis

Ref Level	Reference level
m.+el.Att	Mechanical and electronic RF attenuation
Offset	Reference level offset
AQT	Measurement time for data acquisition.
RBW	Resolution bandwidth
DBW	Demodulation bandwidth
Freq	Center frequency for the RF signal

Window title bar information

For each diagram, the header provides the following information:



Figure 2-1: Window title bar information in the application for analog modulation analysis

- 1 = Window number
- 2 = Window type
- 3 = Trace color
- 4 = Trace number
- 5 = Detector
- 6 = Trace mode
- 7 = Reference value (at the defined reference position)
- 8 = AF coupling (AC/DC), only in AF time domains, if applicable
- 9 = Results are selected for demodulation output

Diagram footer information

The diagram footer (beneath the diagram) contains the following information, depending on the evaluation:

"RF Spectrum"		
CF: Center frequency of input signal	Sweep points	Span: measured span

RF Time domain		
CF: Center frequency of input signal	Sweep points	Time per division

AF Spectrum		
AF CF: center frequency of demodulated signal	Sweep points	AF Span: evaluated span

AF Time domain		
CF: Center frequency of input signal	Sweep points	Time per division

For most modes, the number of sweep points shown in the display are indicated in the diagram footer. In zoom mode, the (rounded) number of currently displayed points are indicated.

Status bar information

Global instrument settings, the instrument status and any irregularities are indicated in the status bar beneath the diagram.

Furthermore, the progress of the current operation is displayed in the status bar.

3 Measurements and result displays

Access: "Overview" > "Display Config"

Or: [MEAS] > "Display Config"

The data that was measured by the R&S ESW can be evaluated using various different methods. In the Analog Modulation Analysis application, up to six evaluation methods can be displayed simultaneously in separate windows. The results can be displayed as absolute deviations or relative to a reference value or level.



The abbreviation "AF" (for Audio Frequency) refers to the demodulated AM, FM or PM signal.

Basis for evaluation

All evaluations are based on the I/Q data set acquired during the measurement. The spectrum of the modulated signal to be evaluated is determined by the demodulation bandwidth. However, it can be restricted to a limited span ("AF Span") if only part of the signal is of interest. Furthermore, the time base for evaluations in the time domain can be restricted to analyze a smaller extract in more detail, see [Section 4.6, "Time domain zoom"](#), on page 29.

AM Time Domain	13
FM Time Domain	14
PM Time Domain	15
AM Spectrum	16
FM Spectrum	17
PM Spectrum	18
RF Time Domain	19
RF Spectrum	20
Result Summary	21
Marker Table	23
Marker Peak List	23

AM Time Domain

Displays the modulation depth of the demodulated AM signal (in %) versus time.

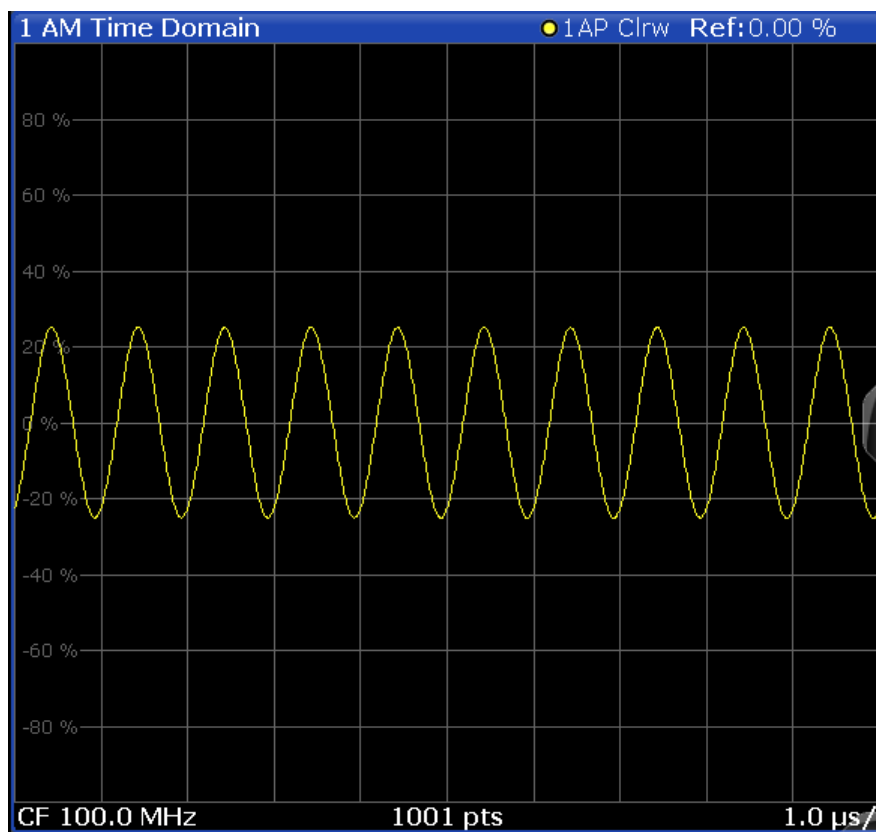

Remote command:

```
LAY:ADD? '1',RIGH,'XTIM:AM:REL'
```

(See [LAYout:ADD\[:WINDow\]?](#) on page 157)

FM Time Domain

Displays the frequency spectrum of the demodulated FM signal versus time.

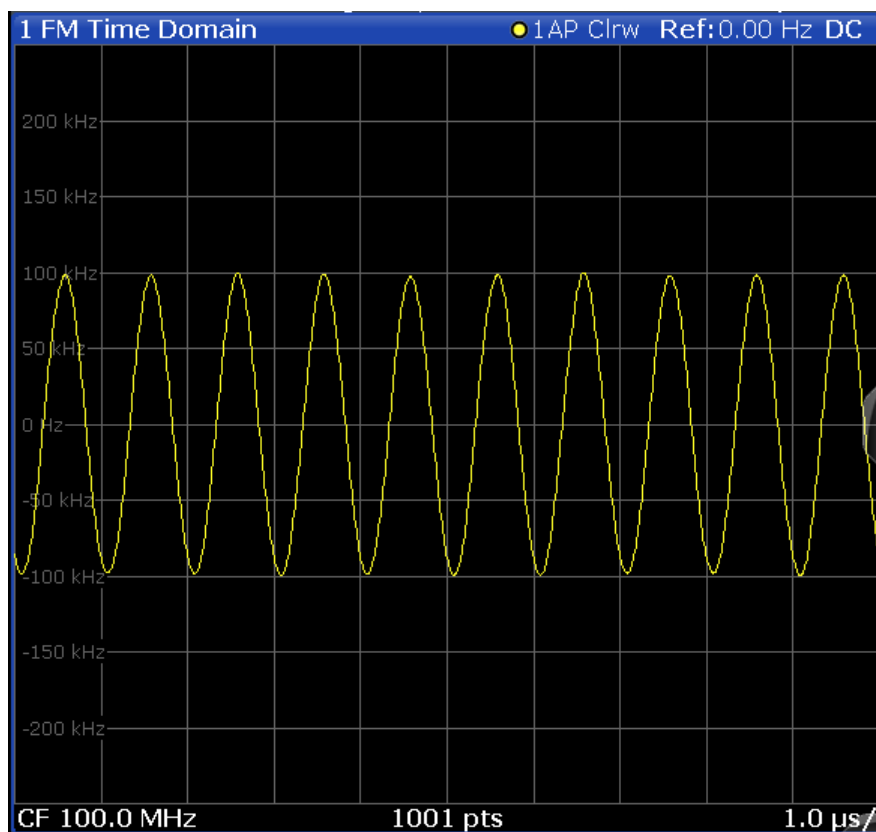

Remote command:

```
LAY:ADD? '1',RIGH,'XTIM:FM'
```

(See [LAYout:ADD\[:WINDow\]?](#) on page 157)

PM Time Domain

Displays the phase deviations of the demodulated PM signal (in rad or °) versus time.

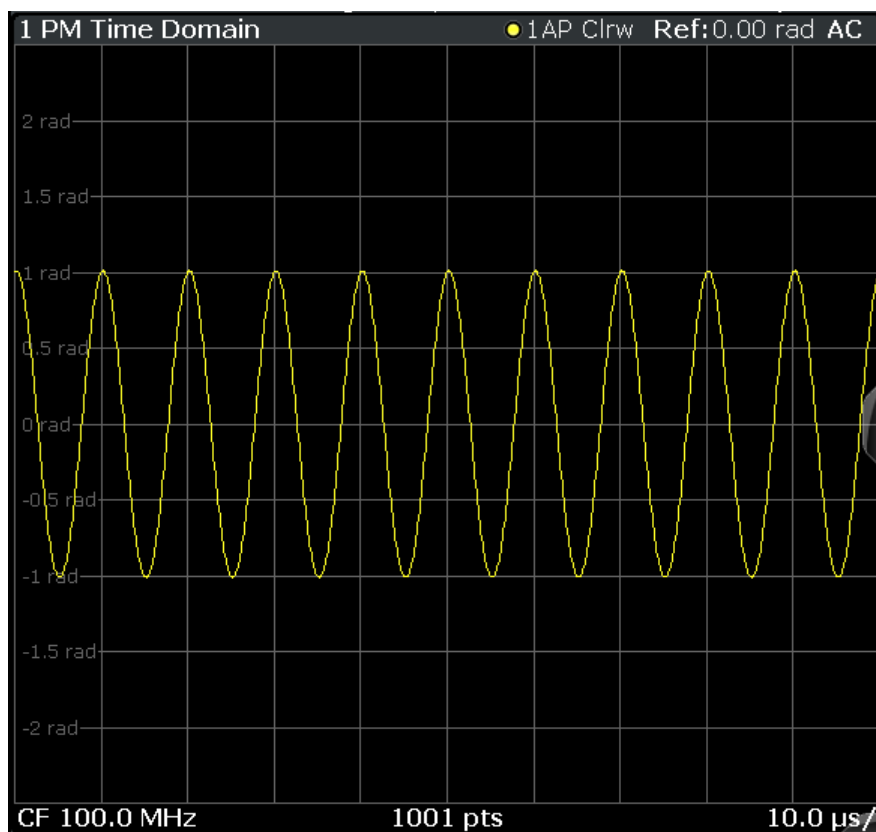

Remote command:

```
LAY:ADD? '1',RIGH,'XTIM:PM'
```

(See [LAYout:ADD\[:WINDow\]?](#) on page 157)

AM Spectrum

Displays the modulation depth of the demodulated AM signal (in % or dB) versus AF span. The spectrum is calculated from the demodulated AM signal in the time domain via FFT.

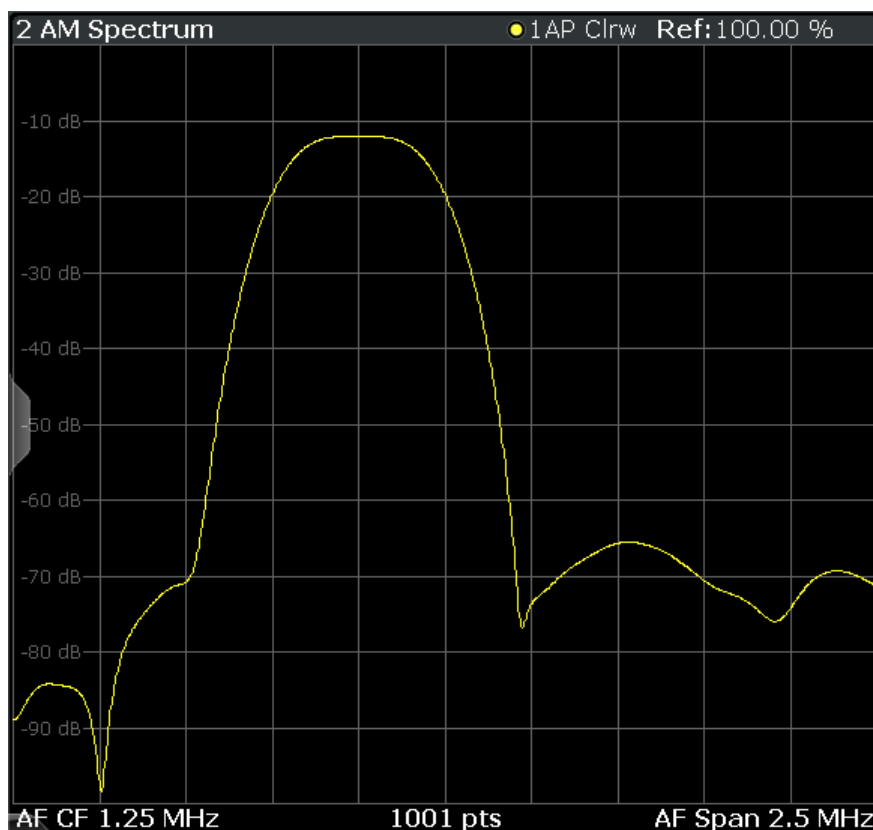

Note: If a high pass or low pass AF filter is defined, the filter is indicated by a vertical red line in the spectrum display.

Remote command:

```
LAY:ADD? '1',RIGH,'XTIME:AM:REL:AFSPpectrum1'
```

(see [LAYout:ADD\[:WINDow\]?](#) on page 157)

FM Spectrum

Displays the frequency deviations of the demodulated FM signal (in Hz or dB) versus AF span. The spectrum is calculated from the demodulated AM signal in the time domain via FFT.

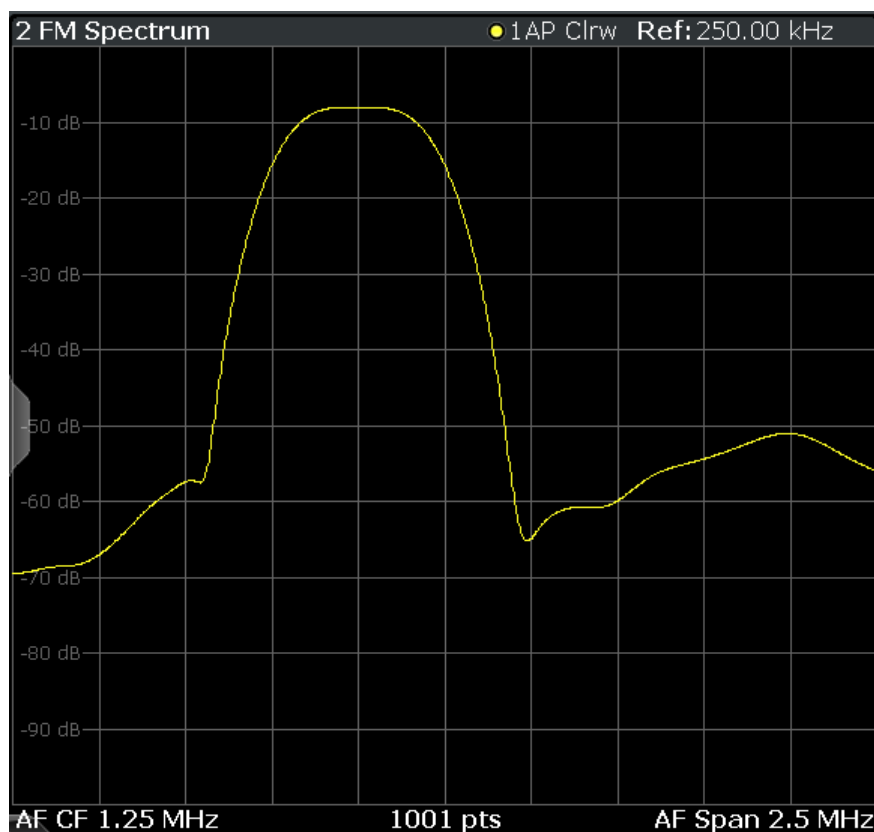

Note: If a high pass or low pass AF filter is defined, the filter is indicated by a vertical red line in the spectrum display.

Remote command:

```
LAY:ADD? '1',RIGH,'XTIME:FM:AFSPpectrum1'
```

(see [LAYout:ADD\[:WINDow\]?](#) on page 157)

PM Spectrum

Displays the phase deviations of the demodulated PM signal (in rad, ° or dB) versus AF span. The spectrum is calculated from the demodulated AM signal in the time domain via FFT.

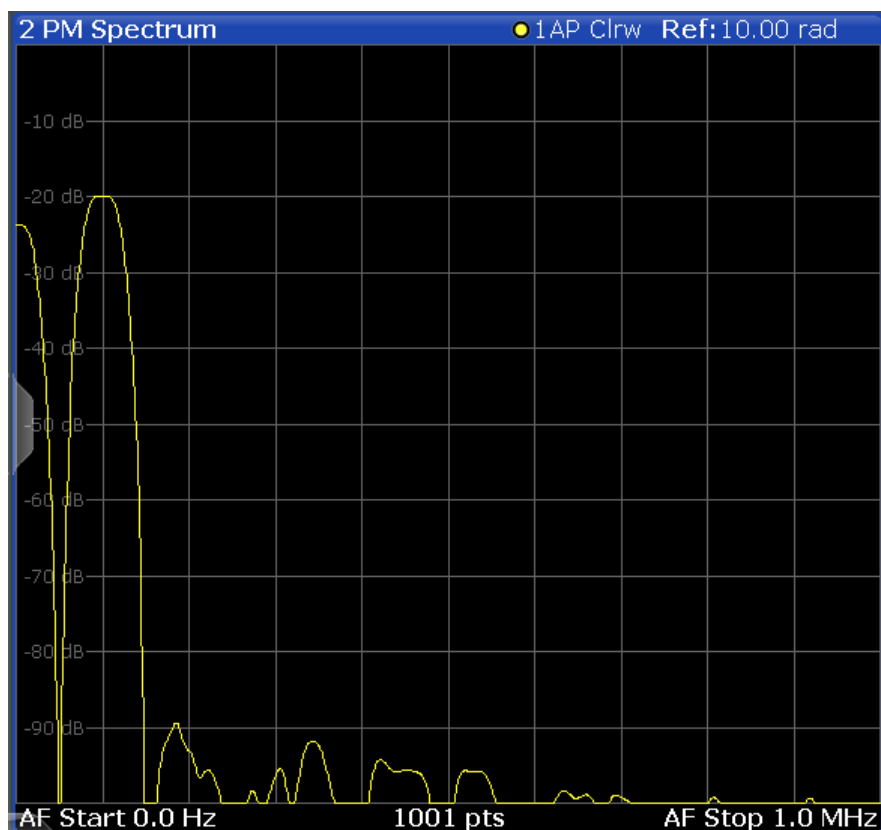

Note: If a high pass or low pass AF filter is defined, the filter is indicated by a vertical red line in the spectrum display.

Remote command:

```
LAY:ADD? '1',RIGH,'XTIME:PM:AFSPpectrum1'
```

(see [LAYout:ADD\[:WINDow\]?](#) on page 157)

RF Time Domain

Displays the RF power of the input signal versus time. The level values represent the magnitude of the I/Q data set.

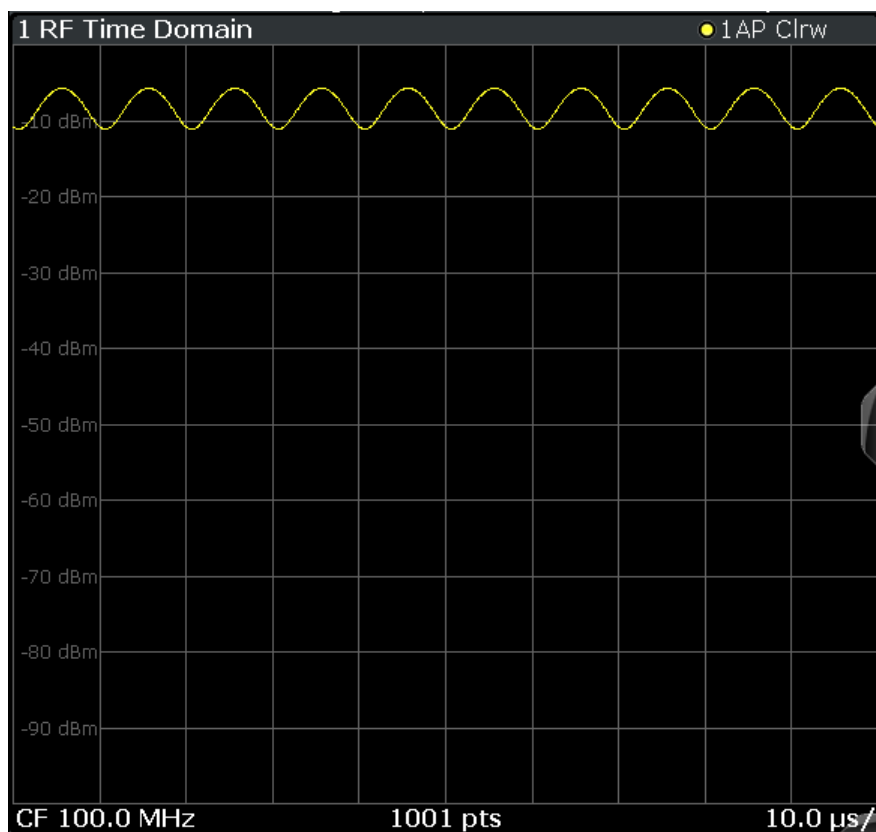

Remote command:

```
LAY:ADD? '1',RIGH,'XTIM:AM'
```

(see [LAYout:ADD\[:WINDow\]?](#) on page 157)

RF Spectrum

Displays the spectrum of the input signal. In contrast to the Spectrum application, the frequency values are determined using FFT from the recorded I/Q data set.

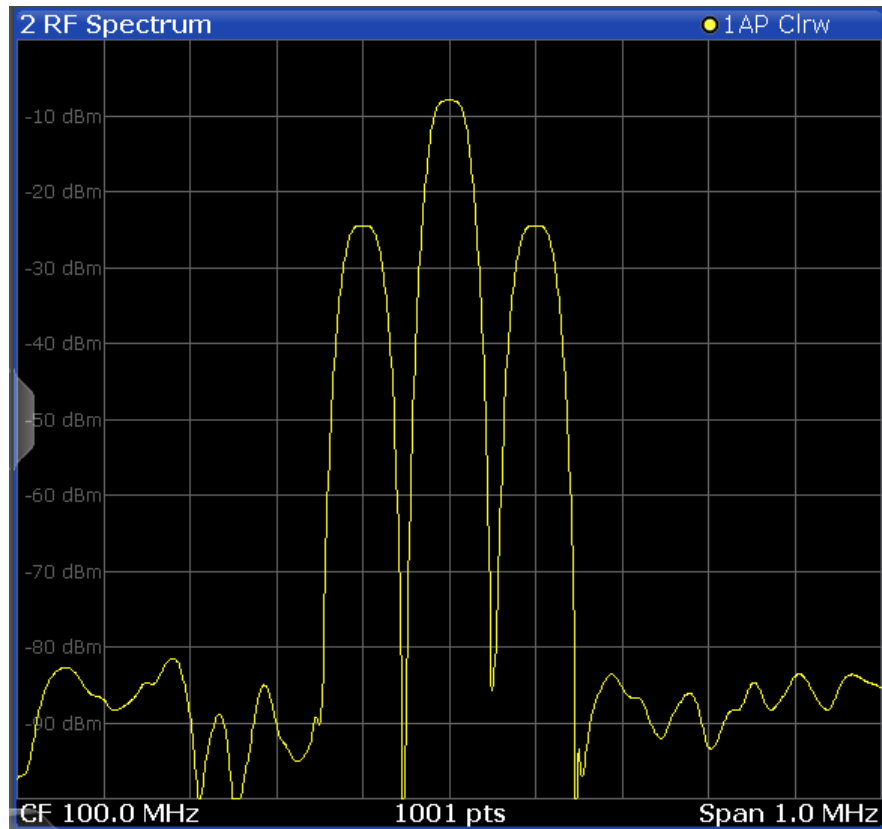

Remote command:

```
LAY:ADD? '1',RIGH,'XTIM:SPECTRUM'
```

(see [LAYout:ADD\[:WINDow\]?](#) on page 157)

Result Summary

The "result summary" displays the results of the demodulation functions for all windows in a table.

4 Result Summary	
Carr Power	-33.57 dBm
Carr Offset	-3.077124 kHz
AM	
+Peak	4.58 %
-Peak	0.678 %
±Peak/2	1.13 %
RMS	7.036 %
Mod. Freq.	---
Mod. Depth	9.82 %
SINAD	---
DISTORT	---
THD	---

The following general results are provided:

For each demodulation, the following results are provided:

Label	Description
"Carr Power"	Measured carrier power
"Carr Offset"	Carrier offset to nominal center frequency
"Mod. Depth"	Modulation depth

Table 3-1: Result summary description

Label	Description
"+Peak"	Positive peak (maximum)
"-Peak"	Negative peak (minimum)
" +/-Peak/2"	Average of positive and negative peaks
"RMS"	Root Mean Square value
"Mod Freq"	Modulation frequency
"SINAD"	<p>Signal-to-noise-and-distortion (Calculated only if AF Spectrum is displayed)</p> <p>Measures the ratio of the total power to the power of noise and harmonic distortions. The noise and harmonic power is calculated inside the AF spectrum span. The DC offset is removed before the calculation.</p> $SINAD[dB] = 20 \cdot \log\left[\frac{P_{total}}{P_{Noise} + P_{distortion}}\right]$
"DISTORT"	<p>Modulation distortion in % (Calculated only if "SINAD" is also calculated)</p> <p>Measures the distortion of the modulation in relation to the total power of the signal inside the AF spectrum span. Indicates the quality of the modulation.</p> $Modulation\ distortion = \frac{\sqrt{P_{total} - P_{signal}}}{\sqrt{P_{total}}} * 100\%$
"THD"	<p>Total harmonic distortion</p> <p>The ratio of the harmonics to the fundamental and harmonics. All harmonics inside the AF spectrum span are considered up to the tenth harmonic. (Calculated only if AF Spectrum is displayed)</p> $THD[dB] = 20 \cdot \log\left[\frac{\sqrt{\sum_{i=2}^{\infty} U_i^2}}{\sqrt{\sum_{i=1}^{\infty} U_i^2}}\right]$

Note: Relative demodulation results. Optionally, the demodulation results in relation to user-defined or measured reference values are determined. See [Section 5.9.6, "Result table settings"](#), on page 75.

In addition, the following general information for the input signal is provided:

- "Carrier Power": the power of the carrier without modulation
- "Carrier Offset": the deviation of the calculated carrier frequency to the ideal carrier frequency
- "Modulation Depth" (AM or "RF Time Domain" only): the difference in amplitude the carrier signal is modulated with

Remote command:

LAY:ADD? '1', RIGH, RSUM, see LAYout:ADD[:WINDow]? on page 157

Results:

[Section 10.6.2, "Retrieving result summary values"](#), on page 169

Marker Table

Displays a table with the current marker values for the active markers.

This table is displayed automatically if configured accordingly.

1 Marker Table							
Wnd	Type	Ref	Trc	X-Value	Y-Value	Function	Function Result
2	M1		1	2.1725 ms	-6.80 dBm		
2	D2	M1	1	13.859 ms	-0.00 dB		
2	D3	M1	1	4.6259 ms	-0.00 dB		
2	D4	M1	1	9.2331 ms	-0.00 dB		

Tip: To navigate within long marker tables, simply scroll through the entries with your finger on the touchscreen.

Remote command:

LAY:ADD? '1', RIGH, MTAB, see LAYout:ADD[:WINDow]? on page 157

Results:

[CALCulate<n>:MARKer<m>:X](#) on page 168

[CALCulate<n>:MARKer<m>:Y?](#) on page 168

Marker Peak List

The marker peak list determines the frequencies and levels of peaks in the spectrum or time domain. How many peaks are displayed can be defined, as well as the sort order. In addition, the detected peaks can be indicated in the diagram. The peak list can also be exported to a file for analysis in an external application.

3 Marker Peak List				
Wnd	No	X-Value	Y-Value	
2	1	1.086245 ms	-75.810 dBm	
2	2	2.172490 ms	-6.797 dBm	
2	3	3.258736 ms	-76.448 dBm	
2	4	4.831918 ms	-76.676 dBm	
2	5	6.255274 ms	-76.482 dBm	
2	6	6.798397 ms	-6.800 dBm	
2	7	9.233084 ms	-76.519 dBm	
2	8	10.075861 ms	-76.172 dBm	
2	9	11.405574 ms	-6.801 dBm	

Tip: To navigate within long marker peak lists, simply scroll through the entries with your finger on the touchscreen.

Remote command:

LAY:ADD? '1', RIGH, PEAK, see LAYout:ADD[:WINDow]? on page 157

Results:

[CALCulate<n>:MARKer<m>:X](#) on page 168

[CALCulate<n>:MARKer<m>:Y?](#) on page 168

4 Measurement basics

Some background knowledge on basic terms and principles used in Analog Modulation Analysis measurements is provided here for a better understanding of the required configuration settings.

- [Demodulation process](#)..... 24
- [Demodulation bandwidth](#).....26
- [Sample rate and demodulation bandwidth](#).....27
- [AF triggers](#).....29
- [AF filters](#).....29
- [Time domain zoom](#).....29
- [Receiving data input and providing data output](#).....31

4.1 Demodulation process

The demodulation process is shown in [Figure 4-1](#). All calculations are performed simultaneously with the same I/Q data set. Magnitude (= amplitude) and phase of the complex I/Q pairs are determined. The frequency result is obtained from the differential phase.

For details on general I/Q data processing in the R&S ESW, refer to the reference part of the I/Q Analysis remote control description in the R&S ESW User Manual.

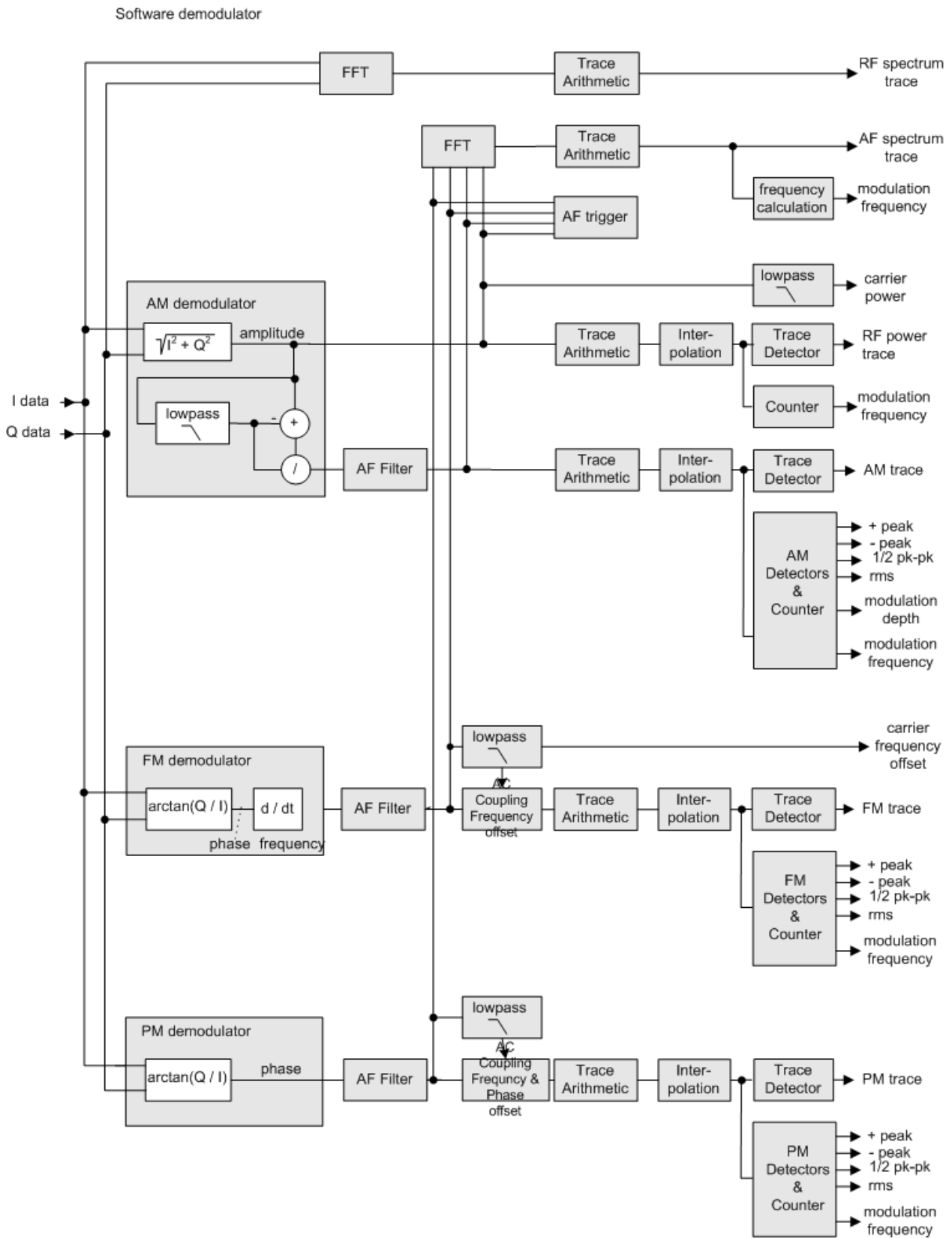

Figure 4-1: Block diagram of software demodulator

The AM DC, FM DC and PM DC raw data of the demodulators is fed into the "Trace Arithmetic" block that combines consecutive data sets. Possible trace modes are: Clear Write, Max Hold, Min Hold and Average. The output data of the "Trace Arithmetic" block can be read via remote control ([SENS:]ADEM:<evaluation>:RES?, see [SENSe:]ADEMod:AM[:ABSolute] [:TDOMain]:RESult? on page 164.

The collected measured values are evaluated by the selected detector. The result is displayed on the screen and can be read out via remote control.

In addition, important parameters are calculated:

- A counter determines the modulation frequency for AM, FM, and PM.
- average power = carrier power (RF power)
- average frequency = carrier frequency offset (FM)
- The modulation depth or the frequency or phase deviation; the deviations are determined from the trace data

AC coupling is possible with FM and PM display.

4.2 Demodulation bandwidth

The demodulation bandwidth determines the span of the signal that is demodulated. It is not the 3-dB bandwidth of the filter, but the useful bandwidth which is distortion-free regarding phase and amplitude.

Therefore the following formulas apply:

- AM: demodulation bandwidth $\geq 2 \times$ modulation frequency
- FM: demodulation bandwidth $\geq 2 \times$ (frequency deviation + modulation frequency)
- PM: demodulation bandwidth $\geq 2 \times$ modulation frequency \times (1 + phase deviation)



If the center frequency of the analyzer is not set exactly to the signal frequency, the demodulation bandwidth must be increased by the carrier offset, in addition to the requirement described above. The bandwidth must also be increased if FM or PM AC coupling is selected.

In general, select the demodulation bandwidth as narrow as possible to improve the S/N ratio. The residual FM caused by noise floor and phase noise increases dramatically with the bandwidth, especially with FM.

For help on determining the adequate demodulation bandwidth, see "[Determining the demodulation bandwidth](#)" on page 91.

A practical example is described in [Section 8, "Measurement example: demodulating an FM signal"](#), on page 86.

4.3 Sample rate and demodulation bandwidth

The maximum demodulation bandwidths that can be obtained during the measurement, depending on the sample rate, are listed in the tables below for different demodulation filter types. The allowed value range of the measurement time and trigger offset depends on the selected demodulation bandwidth and demodulation filter. If the AF filter or the AF trigger are not active, the measurement time increases by 20 %.



A maximum of 24 million samples can be captured, assuming sufficient memory is available; thus the maximum measurement time can be determined according to the following formula:

$$\text{Meas.time}_{\text{max}} = \text{Sample count}_{\text{max}} / \text{sample rate}$$

The minimum trigger offset is $(-\text{Meas.time}_{\text{max}})$

Table 4-1: Available demodulation bandwidths and corresponding sample rates

Demodulation BW	Sample Rate (Flat Top)	Sample Rate (Gaussian Top)
100 Hz	125 Hz	400 Hz
200 Hz	250 Hz	800 Hz
300 Hz	375.00375003750037 Hz	1.200019200307205 kHz
400 Hz	500 Hz	1.6 kHz
500 Hz	625 Hz	2 kHz
800 Hz	1 kHz	3.2 kHz
1 kHz	1.25 kHz	4 kHz
1.6 kHz	2 kHz	6.400409626216077 kHz
2 kHz	2.5 kHz	8 kHz
3 kHz	3.7503750375037503 kHz	12.00192030724916 kHz
3.2 kHz	4 kHz	12.800819252432155 kHz
5 kHz	6.25 kHz	20 kHz
6.4 kHz	8 kHz	25.60163850486431 kHz
10 kHz	12.5 kHz	40 kHz
12.5 kHz	15.625 kHz	50 kHz
20 kHz	25 kHz	80 kHz
25 kHz	31.25 kHz	100 kHz
30 kHz	37.509377344336084 kHz	120.19230769230769 kHz
50 kHz	62.5 kHz	200 kHz
100 kHz	125 kHz	400 kHz
200 kHz	250 kHz	806.4516129032258 kHz
300 kHz	375.939.84962406015 kHz	1.2195121951219512 MHz

Demodulation BW	Sample Rate (Flat Top)	Sample Rate (Gaussian Top)
400 kHz	500 kHz	1.6129032258064516 MHz
500 kHz	625 kHz	2 MHz
800 kHz	1 MHz	3.333333333333335 MHz
1 MHz	1.25 MHz	4.166666666666665 MHz
1.6 MHz	2 MHz	6.25 MHz
2 MHz	2.5 MHz	8.333333333333333 MHz
3 MHz	3.846153846153846 MHz	12.5 MHz
5 MHz	6.25 MHz	25 MHz
8 MHz	10 MHz	50 MHz
10 MHz	12.5 MHz	50 MHz
18 MHz	25 MHz	100 MHz
20 MHz	25 MHz	100 MHz
28 MHz	50 MHz	100 MHz
30 MHz	50 MHz	100 MHz
40 MHz	50 MHz	n/a
50 MHz	100 MHz	n/a
80 MHz	100 MHz	n/a

Large numbers of samples

Principally, the R&S ESW can handle up to 24 million samples. However, when 480001 samples are exceeded, all traces that are not currently being displayed in a window are deactivated to improve performance. The traces can only be activated again when the samples are reduced.



Effects of measurement time on the stability of measurement results

Despite amplitude and frequency modulation, the display of carrier power and carrier frequency offset is stable.

Stability is achieved by a digital filter which sufficiently suppresses the modulation. As a prerequisite, the measurement time must be $\geq 3 \times 1 / \text{modulation frequency}$, i.e. at least three periods of the AF signal are recorded.

The mean carrier power for calculating the AM is also calculated with a digital filter. The filter returns stable results after a measurement time of $\geq 3 \times 1 / \text{modulation frequency}$, i.e. at least three cycles of the AF signal must be recorded before a stable AM can be shown.

4.4 AF triggers

The Analog Modulation Analysis application allows triggering to the demodulated signal. The display is stable if a minimum of five modulation periods are within the recording time.

Triggering is always DC-coupled. Therefore triggering is possible directly to the point where a specific carrier level, phase or frequency is exceeded or not attained.

4.5 AF filters

Additional filters applied after demodulation help filter out unwanted signals, or correct pre-emphasized input signals. A CCITT filter allows you to evaluate the signal by simulating the characteristics of human hearing.

4.6 Time domain zoom

For evaluations in the time domain, the demodulated data for a particular time span can be extracted and displayed in more detail using the "Time Domain Zoom" function. Zooming is useful if the measurement time is very large and thus each sweep point represents a large time span. The time domain zoom function distributes the available sweep points only among the time span defined by the zoom area length. The time span displayed per division of the diagram is decreased. Thus, the display of the extracted time span becomes more precise.

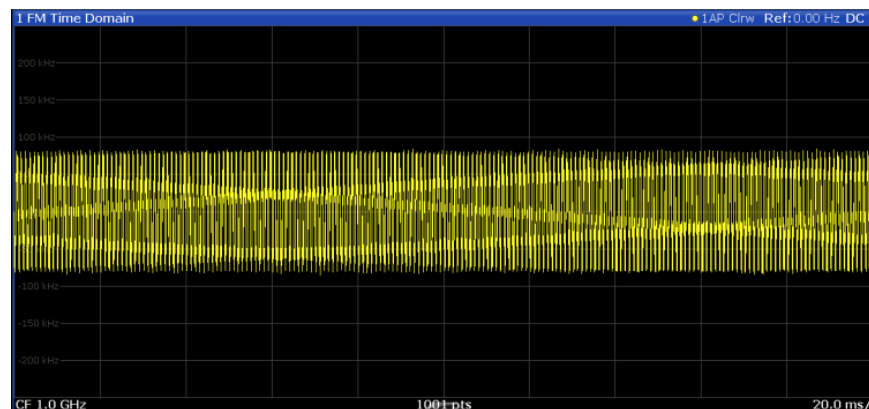

Figure 4-2: FM time domain measurement with a very long measurement time (200 ms)

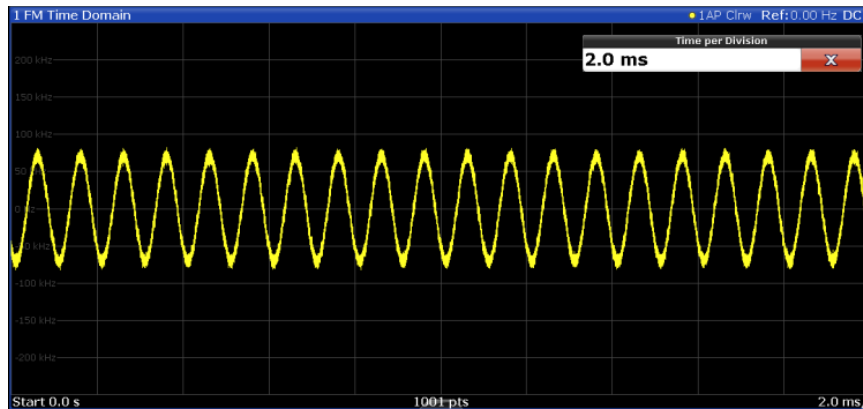
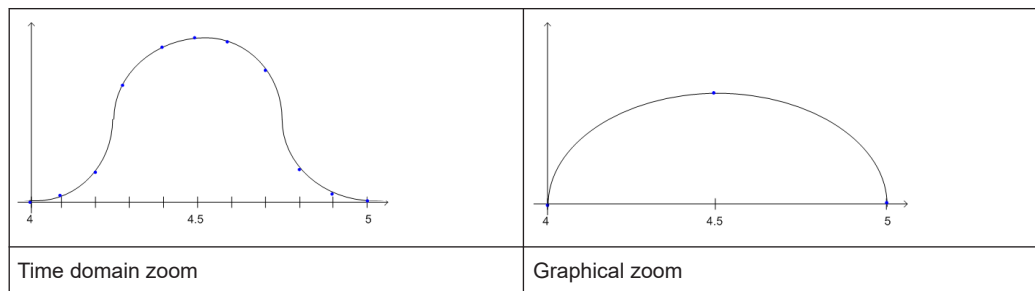
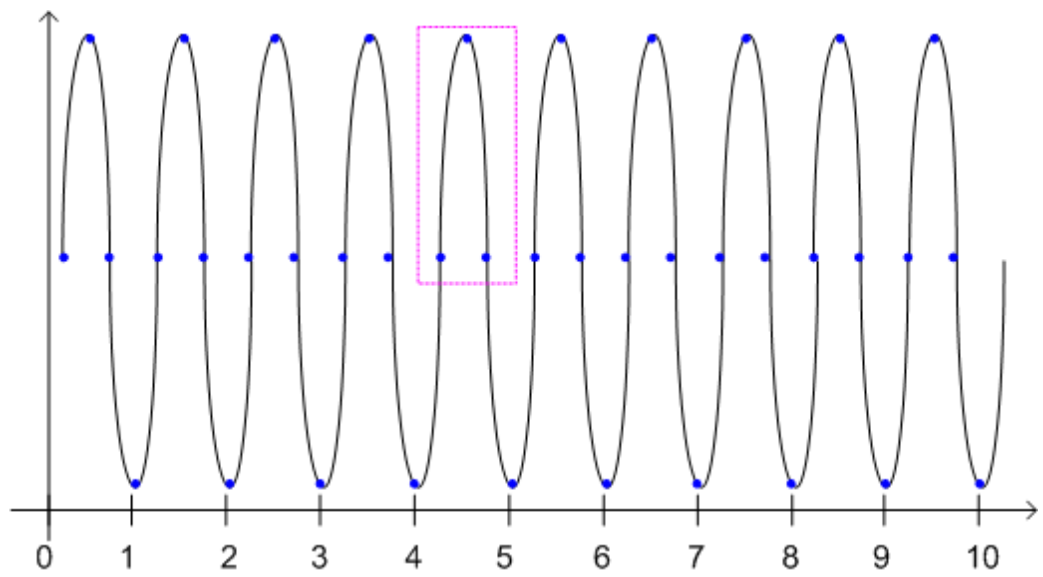

Figure 4-3: FM time domain measurement with time domain zoom (2.0 ms per division)

The time domain zoom area affects not only the diagram display, but the entire evaluation for the current window.

In contrast to the time domain zoom, the graphical zoom is available for all diagram evaluations. However, the graphical zoom is useful only if more measured values than trace points are available. The (time) span represented by each measurement point remains the same.



4.7 Receiving data input and providing data output

The R&S ESW can analyze signals from different input sources and provide various types of output (such as noise or trigger signals).

- [Increasing measurement sensitivity \(or avoiding an input mixer overload\)](#).....31
- [Receiving and providing trigger signals](#)..... 34

4.7.1 Increasing measurement sensitivity (or avoiding an input mixer overload)

Measurements often confront you with unknown or unintentional signals with unknown signal levels (and often with pulse characteristics). Such signals can either have very weak signal levels, in which case you might miss them during the measurement. Or they can have very strong signal levels, in which case they can damage the input mixer.

Protecting the input mixer

Always consider how to protect the input mixer from damage when setting up a measurement.

- ▶ **NOTICE!** EMC measurements often measure unknown signals that contain pulses with possibly strong signal levels. Strong signal levels can damage the input mixer. Read the following topics carefully before you apply a signal to learn more about protecting the input mixer and avoid an overload.

Note that pulses have different level characteristics. Refer to the specifications document for more information on the allowed maximum pulse energy.

The signal level at the input mixer is calculated as follows.

Mixer Level = Input Level - attenuation + gain



The R&S ESW is equipped with an overload protection mechanism. This mechanism becomes active as soon as the signal level at the input mixer exceeds the specified limit. It ensures that the connection between RF input and input mixer is cut off.

In this case, you must decrease the level at the RF input connector and then close the message box. Then measurements are possible again.

- [Using the RF attenuator](#).....31
- [Using the preamplifier](#)..... 32
- [Using the preselector](#)..... 33

4.7.1.1 Using the RF attenuator

The first tool provided by the R&S ESW to control measurement sensitivity is the RF attenuator.

The RF attenuator is available in all hardware configurations of the R&S ESW.

Attenuation has the following effects on the measurement:

- High attenuation protects the input mixer: the main purpose of the attenuator is to protect the input mixer.
- High attenuation makes sure that the measurement results are reliable (signals that are stronger than allowed can distort the results)
- High attenuation helps you to avoid intermodulation
- High attenuation increases inherent noise (i.e. the noise floor) and thus decreases measurement sensitivity: if you increase attenuation by 10 dB, the sensitivity is reduced by 10 dB (in other words: the displayed noise increases by 10 dB)

Depending on the required test setup, you must find a compromise between a high sensitivity, low intermodulation and input mixer protection. We recommend to let the R&S ESW determine the ideal attenuation automatically.

You can determine the attenuation automatically with the auto ranging feature in the receiver application and the auto attenuation feature in the other applications. Determining the attenuation automatically might not necessarily utilize the maximum dynamic range, but still yields valid and reliable results.

When you select the attenuation manually and are measuring unknown signals, especially DUTs with a high RFI voltage, always select the highest possible attenuation level before you apply the signal.

If you need a better sensitivity or signal-to-noise ratio, make sure that the applied signal does not exceed the specified limits, before you lower the attenuation.

For further protection of the input mixer, the R&S ESW does not allow you to select attenuation levels of less than 10 dB unless you explicitly turn on this feature ("[10 dB Minimum Attenuation](#)").

Protecting the input mixer

1. **NOTICE!** EMC measurements often measure unknown signals that contain pulses with possibly strong signal levels. Strong signal levels can damage the input mixer. Select an appropriate attenuation when you measure unknown signals or RFI voltage in combination with an artificial network (LISN). Do not apply a 0 dB attenuation for such measurements. During phase switching, such test setups generate very strong pulses which can damage the input mixer.
2. Make sure that the signal level at the RF input does not exceed the allowed limits when you allow attenuation of less than 10 dB in combination with auto ranging. Exceeding the limits can damage the input mixer.

4.7.1.2 Using the preamplifier

The second tool that allows you to control measurement sensitivity is the preamplifier.

In addition to the standard preamplifier available in every R&S ESW, an additional low noise amplifier is available as an optional component (R&S ESW-B24).

Signal gain has the following effects on the measurement:

- The preamplifier allows you to detect even weak signals.
- The preamplifier reduces the noise figure of the R&S ESW and thus increases its sensitivity. Thus, it is recommended to use the preamplifier for measurements that require maximum sensitivity.
- The preamplifier reduces the dynamic range. To perform a measurement using the maximum dynamic range, turn off the preamplifier.
- The preamplifier is located after the preselection filters, reducing the risk of overloading the input mixer by strong out-of-band signals.
- The optional low noise amplifier is located in front of the preselection filters which increases the measurement sensitivity.

The gain of the preamplifier is automatically considered in the level display. The disadvantage of a lower large-signal immunity (intermodulation) is reduced by the "preselector".

4.7.1.3 Using the preselector

The "preselector" is another tool to control measurement sensitivity.

Preselection has the following effects on the measurement:

- Preselection rejects most of the spectral energy which helps to protect the input mixer and thus makes sure that the measurement results are valid and reliable.
- Preselection filters out signals that you do not want to be displayed (selectivity) and thus allows you to analyze only the frequency range you are interested in.

The preselector of the R&S ESW consists of several filters which are automatically applied during measurements. The filter that is used depends on the frequency that is currently measured. You can see the list of filters and the progress in the "Preselector" result display. The currently applied filter is indicated by a green LED, filters that are outside the scan range are ignored.

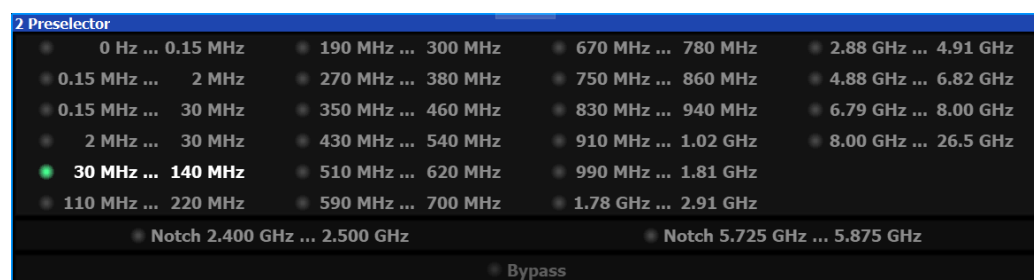

Figure 4-4: Preselector result display. The green LED indicates the currently applied filter.

In the frequency range from 150 kHz to 30 MHz, you can preselect in a single stage (150 kHz to 30 MHz). Or, you can split the preselection into two stages, each of which applies a separate filter: one from 150 kHz to 2 MHz, and another from 2 MHz to 30 MHz.

In addition, the R&S ESW provides several notch filters to suppress certain frequency ranges completely.



Using the preselector

Switching the filters is a mechanical process. Avoid excessive filters switches, because the hardware can wear out.

Note that results in a frequency band are only displayed if there is at least one valid measurement point in the corresponding range. If a particular measurement point is captured by more than one filter, the R&S ESW displays the combined results.



Notch filter

The R&S ESW provides additional notch filters that suppress signals in the frequency bands from 2.4 GHz to 2.5 GHz and 5.725 GHz to 5.875 GHz.

4.7.2 Receiving and providing trigger signals

Using one of the "trigger" connectors of the R&S ESW, the R&S ESW can use a signal from an external device as a trigger to capture data. Alternatively, the internal trigger signal used by the R&S ESW can be output for use by other connected devices. Using the same trigger on several devices is useful to synchronize the transmitted and received signals within a measurement.

For details on the connectors see the R&S ESW "Getting Started" manual.

External trigger as input

If the trigger signal for the R&S ESW is provided by an external device, the trigger signal source must be connected to the R&S ESW and the trigger source must be defined as "External" in the R&S ESW.

Trigger output

The R&S ESW can provide output to another device either to pass on the internal trigger signal, or to indicate that the R&S ESW itself is ready to trigger.

The trigger signal can be output by the R&S ESW automatically, or manually by the user. If it is provided automatically, a high signal is output when the R&S ESW has triggered due to a measurement start ("Device Triggered"), or when the R&S ESW is ready to receive a trigger signal after a measurement start ("Trigger Armed").

Manual triggering

If the trigger output signal is initiated manually, the length and level (high/low) of the trigger pulse is also user-definable. Note, however, that the trigger pulse level is always opposite to the constant signal level defined by the output "Level" setting, e.g. for "Level" = "High", a constant high signal is output to the connector until "Send Trigger" is selected. Then, a low pulse is provided.

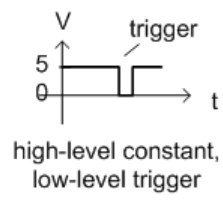
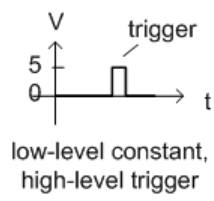

5 Configuration

Access: [MODE] > "Analog Demod"

When you activate the Analog Modulation Analysis application, a Analog Modulation Analysis measurement for the input signal is started automatically with the default configuration. It can be configured in the Analog Modulation Analysis "Overview" dialog box, which is displayed when you select the "Overview" softkey from any menu.



The main configuration settings and dialog boxes are also available via the "Analog Demod" menu which is displayed when you press the [MEAS CONFIG] key.

Predefined settings

For commonly performed measurements, standard setup files are provided for quick and easy configuration. Simply load an existing standard settings file and, if necessary, adapt the measurement settings to your specific requirements.

For an overview of predefined standards and settings see [Section A.1, "Predefined standards and settings"](#), on page 180.

• Configuration according to digital standards	36
• Configuration overview	38
• Data input and output	39
• Amplitude	49
• Frequency	52
• Trigger configuration	53
• Bandwidth settings	59
• Sweep settings	60
• Demodulation	62
• Demodulation display	78
• Automatic settings	78

5.1 Configuration according to digital standards

Access: "Overview" > "Setup Standard"

Various predefined settings files for common digital standards are provided for use with the Analog Modulation Analysis application. In addition, you can create your own settings files for user-specific measurements.

For details on which settings are defined and an overview of predefined standards see [Section A.1, "Predefined standards and settings"](#), on page 180.

The remote commands required to configure digital standards are described in [Section 10.4.1, "Standard selection"](#), on page 101.

Setup Standard	37
L Selecting Storage Location - Drive/ Path/ Files	37
L File Name	37

L Load Standard.....	37
L Save Standard.....	37
L Delete Standard.....	37
L Restore Standard Files.....	38

Setup Standard

Opens a file selection dialog box to select a predefined setup file. The predefined settings are configured in the Analog Modulation Analysis application, which allows for quick and easy configuration for commonly performed measurements.

Selecting Storage Location - Drive/ Path/ Files ← Setup Standard

Select the storage location of the file on the <instrument> or an external drive.

The default storage location for the settings files is:

```
C:\R_S\Instr\User\predefined\AdemodPredefined.
```

Note: Saving instrument settings in secure user mode.

In secure user mode, settings that are stored on the instrument are stored to volatile memory, which is restricted to 256 MB. Thus, a "memory limit reached" error can occur although the hard disk indicates that storage space is still available.

To store data permanently, select an external storage location such as a USB memory device.

For details, see "Protecting Data Using the Secure User Mode" in the "Data Management" section of the R&S ESW base unit user manual.

File Name ← Setup Standard

Contains the name of the data file without the path or extension.

File names must be compatible with the Windows conventions for file names. In particular, they must not contain special characters such as ":", "*", "?".

For details on the filename and location, see the "Data Management" topic in the R&S ESW User Manual.

Load Standard ← Setup Standard

Loads the selected measurement settings file.

Remote command:

```
[SENSe:]ADEMod:PRESet[:STANdard] on page 101
```

Save Standard ← Setup Standard

Saves the current measurement settings for a specific standard as a file with the defined name.

Remote command:

```
[SENSe:]ADEMod:PRESet:STORe on page 102
```

Delete Standard ← Setup Standard

Deletes the selected standard. Standards predefined by Rohde & Schwarz can also be deleted. A confirmation query is displayed to avoid unintentional deletion of the standard.

Note: Restoring predefined standard files. The standards predefined by Rohde & Schwarz available at the time of delivery can be restored using the "Restore Standard Files" function (see "Restore Standard Files" on page 38).

Restore Standard Files ← Setup Standard

Restores the standards predefined by Rohde & Schwarz available at the time of delivery.

Note that this function overwrites customized standards that have the same name as predefined standards.

Remote command:

[SENSe:]ADEMod:PRESet:REStore on page 102

5.2 Configuration overview



Throughout the measurement configuration, an overview of the most important currently defined settings is provided in the "Overview". The "Overview" is displayed when you select the "Overview" icon, which is available at the bottom of all softkey menus.

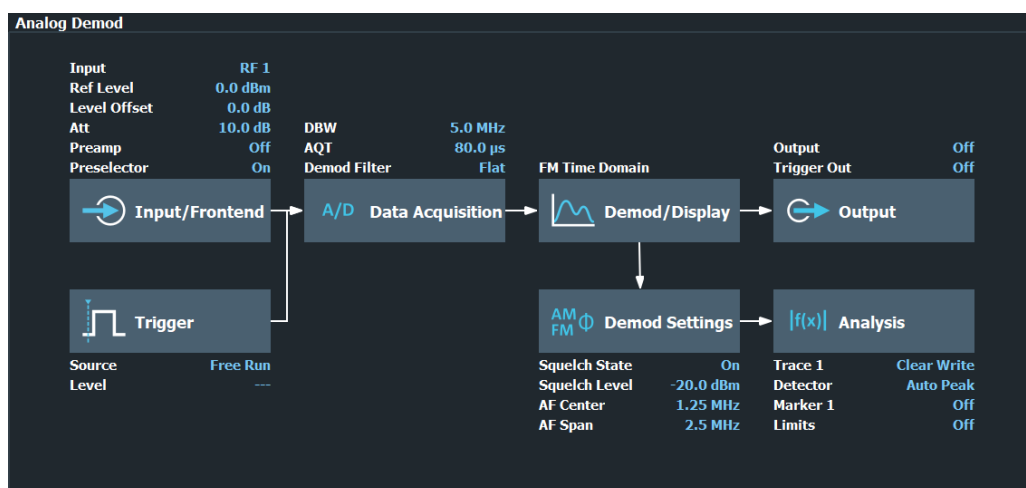

In addition to the main measurement settings, the "Overview" provides quick access to the main settings dialog boxes. Thus, you can easily configure an entire Analog Modulation Analysis measurement channel from input over processing to output and analysis by stepping through the dialog boxes as indicated in the "Overview".

Functions in the "Overview" dialog box described elsewhere:

- "Setup Standard" on page 37

Preset Channel.....	38
Specific Settings for.....	39

Preset Channel

Select "Preset Channel" in the lower left-hand corner of the "Overview" to restore all measurement settings *in the current channel* to their default values.

Note: Do not confuse "Preset Channel" with the [Preset] key, which restores the entire instrument to its default values and thus closes *all channels* on the R&S ESW (except for the default channel)!

Remote command:

`SYSTem:PRESet:CHANnel [:EXEC]` on page 101

Specific Settings for

The channel can contain several windows for different results. Thus, the settings indicated in the "Overview" and configured in the dialog boxes vary depending on the selected window.

Select an active window from the "Specific Settings for" selection list that is displayed in the "Overview" and in all window-specific configuration dialog boxes.

The "Overview" and dialog boxes are updated to indicate the settings for the selected window.

5.3 Data input and output

Access: "Overview" > "Input / Frontend"

Access: "Overview" > "Output"

The R&S ESW can analyze signals from different input sources and provide various types of output (such as video or trigger signals).

I/Q data import and export

You can also analyze I/Q data that you have previously recorded.

For a comprehensive description about I/Q data import and export, refer to the user manual of the R&S ESW.

- [Configuring the RF input](#)..... 39
- [Configuring external mixers](#)..... 41
- [Configuring the preselector](#).....41
- [Configuring external generators](#).....41
- [Configuring outputs \(IF / video / demodulation\)](#)..... 42
- [Configuring line impedance stabilization networks \(LISN\)](#).....46
- [Configuring additional outputs](#).....46

5.3.1 Configuring the RF input

Access: "Overview" > "Input / Frontend" > "Input Source" > "Radio Frequency"

The R&S ESW supports various signal input sources. The default input source is the RF input.

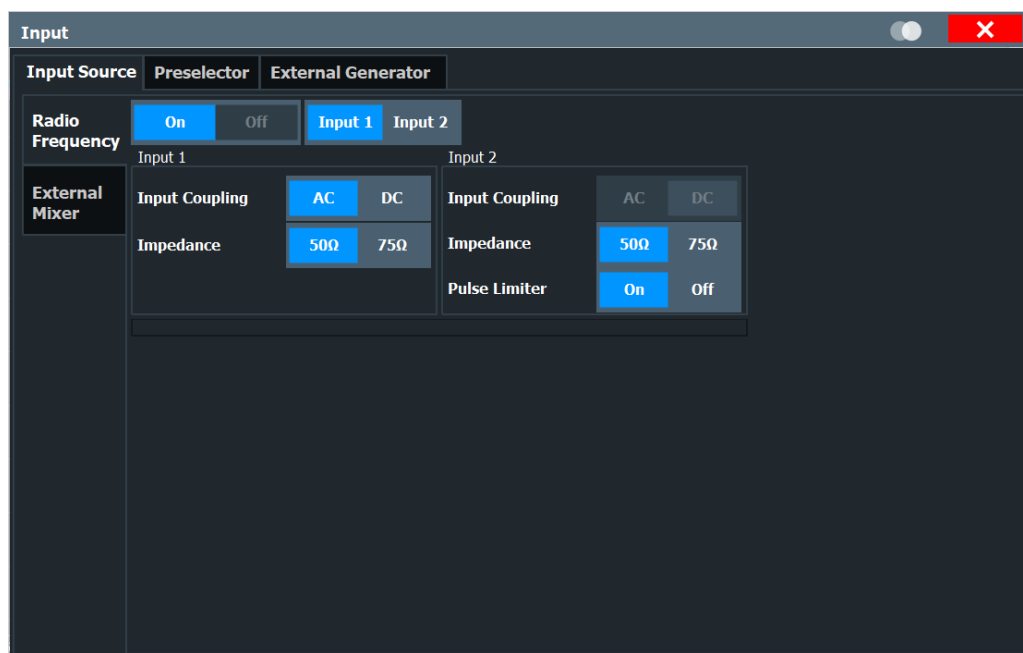

Functions in the "Input" dialog box described elsewhere:

- "Input Selection" on page 40

The remote commands required to configure the RF input are described in [Section 10.4.2.1, "RF input"](#), on page 102.

Input Selection	40
Input Coupling	40
Impedance	41
Pulse Limiter	41

Input Selection

Selects the RF input connector that is used for the scan.

Note that you cannot use both RF inputs simultaneously.

Remote command:

Global: `INPut:TYPE` on page 103

Input Coupling

The RF input of the R&S ESW can be coupled by alternating current (AC) or direct current (DC).

Note that the "Input Coupling" feature is only available for input 2 when the [pulse limiter](#) is turned off. When the pulse limiter is on, the input is always DC coupled.

AC coupling blocks any DC voltage from the input signal. AC coupling is activated by default to prevent damage to the instrument. Very low frequencies in the input signal can be distorted.

However, some specifications require DC coupling. In this case, you must protect the instrument from damaging DC input voltages manually. For details, refer to the specifications document.

Remote command:

[INPut:COUPling](#) on page 103

Impedance

For some measurements, the reference impedance for the measured levels of the R&S ESW can be set to 50 Ω or 75 Ω .

Select 75 Ω if the 50 Ω input impedance is transformed to a higher impedance using a 75 Ω adapter of the RAZ type. (That corresponds to 25 Ω in series to the input impedance of the instrument.) The correction value in this case is 1.76 dB = 10 log (75 Ω /50 Ω).

This value also affects the unit conversion.

Remote command:

[INPut:IMPedance](#) on page 103

Pulse Limiter

The pulse limiter, available for the second RF input, is a protection mechanism against high level pulses or signals (which can damage the input mixer).

When you turn on the pulse limiter, the attenuation is always at least 10 dB. Attenuation smaller than 10 dB is only available when you turn off the pulse limiter.

Remote command:

[INPut:ATTenuation:LIMiter\[:STATe\]](#) on page 102

5.3.2 Configuring external mixers

Access: "Overview" > "Input / Frontend" > "Input Source" > "External Mixer"

Controlling external mixer is available with the optional External Mixer support.

The functionality is the same as in the spectrum application.

For more information about configuring external mixers, refer to the user manual of the spectrum application.

5.3.3 Configuring the preselector

Access: "Overview" > "Input / Frontend" > "Preselector"

The preselector works the same as in the Receiver application.

For more information refer to the user manual of the R&S ESW.

5.3.4 Configuring external generators

Access: "Overview" > "Input / Frontend" > "External Generator"

Controlling external generators is available with the optional External Generator Control. The functionality is the same as in the Receiver application.

For more information about using external generators, refer to the user manual of the R&S ESW.

5.3.5 Configuring outputs (IF / video / demodulation)

Access: "Overview" > "Output" > "Output Config"

The R&S ESW provides several outputs that you can use to transfer a signal to other devices. The R&S ESW allows you to configure the output as required.

For details on the connectors refer to the R&S ESW Getting Started manual, chapter "Instrument Tour".

The "Output" dialog box contains two tabs: one to configure the IF/Video/Demod outputs ("Output Config") and the headphone jack, and another tab to configure other outputs ("Additional Outputs").

The remote commands required to configure the outputs are described in [Section 10.4.3.1, "Signal output"](#), on page 104.

Output Coupling.....	43
Selecting the output type.....	43
L Configuring the output of the IF signal.....	43
L Configuring the output of the Video signal.....	43
L Configuring the output of an AM signal.....	43
L Configuring the output of an FM signal.....	44
Controlling and configuring the output.....	44
L Selecting the window with the output signal.....	44
L IF Output Frequency.....	44
L Coupling.....	44
L Reference Level for Output.....	44
L Low Pass.....	45
L Phones.....	45

L Squelch.....	45
L Scale.....	45
Controlling the volume.....	45

Output Coupling

Selects the scope of the output settings.

"Global"	The output settings apply to all measurement channels / applications.
"Channel Specific"	The output settings apply to the current measurement channel / application only. You can configure each channel separately.

Remote command:

`OUTPut<ou>:LINK` on page 108

Selecting the output type

Selects the type of analog signal you want to output.

"IF Output"	Outputs the IF signal (see " Configuring the output of the IF signal " on page 43 for available settings). (Unavailable for audio output.)
"Video"	Outputs the video signal (see " Configuring the output of the Video signal " on page 43 for available settings).
"AM"	Outputs the AM demodulated signal (see " Configuring the output of an AM signal " on page 43 for available settings).
"FM"	Outputs the FM demodulated signal (see " Configuring the output of an FM signal " on page 44 for available settings).
"Current Focus"	Outputs the data of the currently selected measurement window (highlighted with a blue frame). Available in the Analog Modulation Analysis application.
"Off"	Turns off the output.

Remote command:

`OUTPut<ou>:IF[:SOURce]` on page 107

Configuring the output of the IF signal ← Selecting the output type

For the output of the IF signal, you can adjust the following parameters.

- "[IF Output Frequency](#)" on page 44
- "[Reference Level for Output](#)" on page 44 (read only)

Configuring the output of the Video signal ← Selecting the output type

Additional settings for video signal output are not supported.

Configuring the output of an AM signal ← Selecting the output type

For the output of AM demodulated signals, you can adjust the following parameters.

- "[Selecting the window with the output signal](#)" on page 44
- "[Scale](#)" on page 45
- "[Low Pass](#)" on page 45
- "[Phones](#)" on page 45

Configuring the output of an FM signal ← Selecting the output type

For the output of FM demodulated signals, you can adjust the following parameters.

- "Selecting the window with the output signal" on page 44
- "Coupling" on page 44
- "Scale" on page 45
- "Low Pass" on page 45
- "Phones" on page 45

Controlling and configuring the output

Depending on the selected [output type](#), you can configure one or more of the following output characteristics.

Selecting the window with the output signal ← Controlling and configuring the output

In the Analog Modulation Analysis application, you can analyze a signal in several measurement windows of the same type independently.

In a case like this, you can select the window that the output is based on from the "Window Selection" dropdown menu. This dropdown menu is only available if several windows of the same type are open.

Available in the Analog Modulation Analysis application and for the "AM Time Domain" and "FM Time Domain" results.

Remote command:

`OUTPut:ADEMod[:ONLine]:SOURCE` on page 108

IF Output Frequency ← Controlling and configuring the output

Defines the output frequency of the IF signal.

The range is: $(RBW / 2)$ to $(240 \text{ MHz} - (RBW / 2))$

Remote command:

`OUTPut<ou>:IF:IFFrequency` on page 105

Coupling ← Controlling and configuring the output

Selects the type of current that is transferred at the output.

Available for linear signal output.

"AC Coupling" Rejects the DC component of the signal.
This coupling protects the output from damage, but can distort very low frequencies.

"DC Coupling" Transfers the complete signal (DC and AC components).

Remote command:

`OUTPut<ou>:IF:COUpling` on page 105

Reference Level for Output ← Controlling and configuring the output

Shows the reference level of the signal, if the level of the output signal depends on the reference level of the current measurement.

Remote command:

not supported

Low Pass ← Controlling and configuring the output

Turns a low pass filter to control the frequencies that are output on and off.

When you turn on the filter, you can define its **cutoff frequency**. The available cutoff frequencies depend on the type of output and the individual settings of the selected [output type](#).

Remote command:

[OUTPut<ou>:IF:LPASs\[:STATe\]](#) on page 106

[OUTPut<ou>:IF:LPASs:FREQuency:MANual](#) on page 106

Phones ← Controlling and configuring the output

Turns additional output of the signal on the headphone jack on and off.

When you turn on this feature, you can listen to the signal with speakers or headphones. To control the volume of the output, use either the volume control knob on the front panel or the [volume slider](#) available in the "Phones" dialog box.

Remote command:

[OUTPut<ou>:IF:AUDio](#) on page 105

Squelch ← Controlling and configuring the output

You can suppress noise during audio output over the headphone jack for demodulated AM or FM signals with the "Squelch" feature.

When you turn on this feature, you can define a relative "Squelch Level" in %, below which the signal is not demodulated (and thus not audible). The squelch level is indicated by a red line in the diagram.

Remote command:

[\[SENSe:\]DEMod:SQUelch\[:STATe\]](#) on page 109

[\[SENSe:\]DEMod:SQUelch:LEVel](#) on page 108

Scale ← Controlling and configuring the output

Defines the scale for the data you are transferring.

The unit depends on the signal type you are transferring.

- AM signals: a value in %.
- FM signals: a value in Hz

Remote command:

[OUTPut<ou>:IF:SCALE\[:VALue\]](#) on page 107

Controlling the volume

CAUTION! Risk of hearing damage. To protect your hearing, make sure that the volume setting is not too high before putting on the headphones.

When you output an audio signal and listen to it with headphones, for example, you can control the volume of the output.

One way to control the volume is to use the **volume control knob** on the front panel of the R&S ESW.

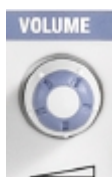

A similar functionality is available in the "Phones" tab of the "Output Config" dialog box.

The **volume control slider** has the same effect as the volume control knob. For the slider, the volume is a percentage from 0 % to 100 % with 100 % being the loudest.

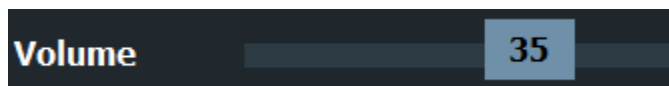

In addition to simply changing the volume, you can also define a **maximum volume level**. The maximum volume level limits the audio output to a certain level.

The volume control knob and slider will not go further than this level.

Remote command:

Volume: [SYSTem:SPEaker:VOLume](#) on page 110

Maximum volume: [SYSTem:SPEaker:MAXVolume](#) on page 109

Mute: [SYSTem:SPEaker:MUTE](#) on page 110

5.3.6 Configuring line impedance stabilization networks (LISN)

Access: "Overview" > "Output" > "LISN"

The R&S ESW supports several LISN models and provides functionality to control these devices. The functionality is the same as in the Receiver application.

For more information refer to the user manual of the R&S ESW.

5.3.7 Configuring additional outputs

Access: "Overview" > "Output" > "Additional Outputs"

The R&S ESW provides additional outputs that you can use for various tasks.

The remote commands required to configure the outputs are described in [Section 10.4.3.2, "Other outputs"](#), on page 110.

Probe Power Supply	46
Trigger 2/3	47
L Output Type	47
L Level	48
L Pulse Length	48
L Send Trigger	48

Probe Power Supply

Selects the probe connector that is supplied with power.

The probe power supply is a global setting - when you change it in one measurement channel, it is also changed in the others.

- "Probe 1" Supplies the 3-pin probe connector with power.
- "Probe 2" Supplies the 5-pin probe connector with power.
- "Off" Turns off the power supply for the probe connectors.

Remote command:

`OUTPut<ou>:PROBe<pb>[:POWer]` on page 110

Trigger 2/3

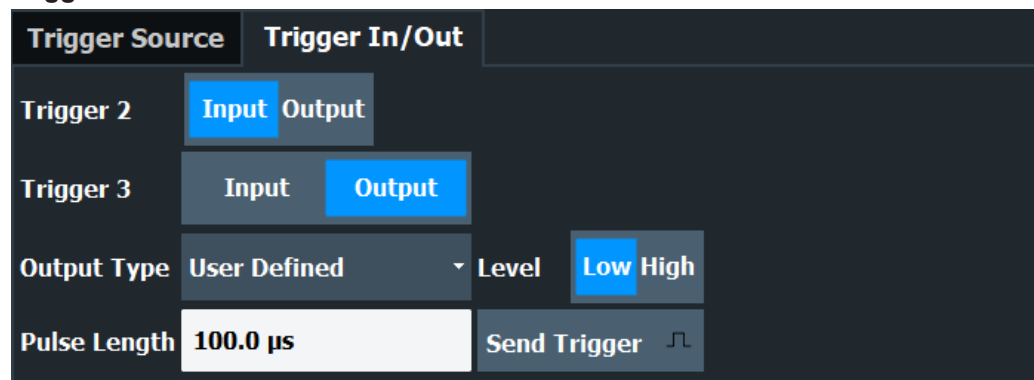

The trigger input and output functionality depends on how the variable "Trigger Input/Output" connectors are used.

Note: Providing trigger signals as output is described in detail in the R&S ESW base unit user manual.

- "Trigger 1" "Trigger 1" is input only.
- "Trigger 2" Defines the usage of the variable "Trigger Input/Output" connector on the front panel
- "Trigger 3" Defines the usage of the variable "Trigger 3 Input/Output" connector on the rear panel
- "Input" The signal at the connector is used as an external trigger source by the R&S ESW. Trigger input parameters are available in the "Trigger" dialog box.
- "Output" The R&S ESW sends a trigger signal to the output connector to be used by connected devices. Further trigger parameters are available for the connector.
Note: For offline AF or RF triggers, no output signal is provided.

Remote command:

`OUTPut:TRIGger<tp>:DIRection` on page 111

Output Type ← Trigger 2/3

Type of signal to be sent to the output

- "Device Triggered" (Default) Sends a trigger when the R&S ESW triggers.

- "Trigger Armed" Sends a (high level) trigger when the R&S ESW is in "Ready for trigger" state.
This state is indicated by a status bit in the `STATUS:OPERation` register (bit 5), as well as by a low-level signal at the "AUX" port (pin 9). For details, see the description of the `STATUS:OPERation` register in the R&S ESW base unit user manual and the description of the "AUX" port in the R&S ESW Getting Started manual.
- "User Defined" Sends a trigger when you select "Send Trigger".
In this case, further parameters are available for the output signal.

Remote command:

`OUTPut:TRIGger<tp>:OTYPe` on page 111

Level ← Output Type ← Trigger 2/3

Defines whether a high (1) or low (0) constant signal is sent to the trigger output connector (for "Output Type": "User Defined").

The trigger pulse level is always opposite to the constant signal level defined here. For example, for "Level" = "High", a constant high signal is output to the connector until you select the [Send Trigger](#) function. Then, a low pulse is provided.

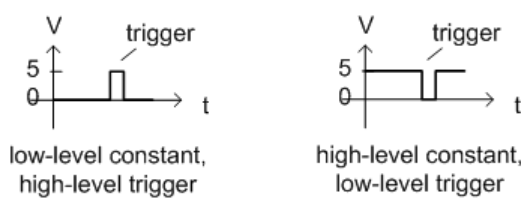

Remote command:

`OUTPut:TRIGger<tp>:LEVel` on page 111

Pulse Length ← Output Type ← Trigger 2/3

Defines the duration of the pulse (pulse width) sent as a trigger to the output connector.

Remote command:

`OUTPut:TRIGger<tp>:PULSe:LENGth` on page 112

Send Trigger ← Output Type ← Trigger 2/3

Sends a user-defined trigger to the output connector immediately.

Note that the trigger pulse level is always opposite to the constant signal level defined by the output [Level](#) setting. For example, for "Level" = "High", a constant high signal is output to the connector until you select the "Send Trigger" function. Then, a low pulse is sent.

Which pulse level is sent is indicated by a graphic on the button.

Remote command:

`OUTPut:TRIGger<tp>:PULSe:IMMediate` on page 112

5.4 Amplitude

Access: "Overview" > "Input / Frontend" > "Amplitude"

The amplitude is configured in the "Amplitude" tab of the "Input" dialog box.

For background information on amplitude settings see the R&S ESW User Manual.

Input Source	Preselector	External Generator	Amplitude	Frequency
Reference Level		Input Settings		
Value	0.0 dBm	Preamplifier	Off	LN Amplifier
Offset	0.0 dB	Input Coupling	AC	DC
Unit	dBm	Impedance	50Ω	75Ω
	Auto Level			
Attenuation				
Mode	Auto	Manual		
Value	10.0 dB			
10 dB Min	On	Off		

The remote commands required to define these settings are described in [Section 10.4.4, "Amplitude configuration"](#), on page 113.

Functions to configure level characteristics described elsewhere:

- "Input Coupling" on page 40
- "Impedance" on page 41

Reference Level.....	49
L Shifting the Display (Offset).....	50
L Unit.....	50
L Setting the Reference Level Automatically (Auto Level).....	50
Attenuation.....	51
10 dB Minimum Attenuation.....	51
Preamplifier.....	51

Reference Level

Defines the expected maximum reference level. Signal levels above this value are possibly not measured correctly. Signals above the reference level are indicated by an "IF Overload" or "OVLD" status display.

The reference level can also be used to scale power diagrams; the reference level is then used for the calculation of the maximum on the y-axis.

Since the hardware of the R&S ESW is adapted according to this value, it is recommended that you set the reference level close above the expected maximum signal level. Thus you ensure an optimal measurement (no compression, good signal-to-noise ratio).

Note that for input from the External Mixer (R&S ESW-B21) the maximum reference level also depends on the conversion loss; see the R&S ESW base unit user manual for details.

Remote command:

`DISPlay[:WINDow<n>][:SUBWindow<w>]:TRACe<t>:Y[:SCALe]:RLEVel`
on page 113

Shifting the Display (Offset) ← Reference Level

Defines an arithmetic level offset. This offset is added to the measured level. In some result displays, the scaling of the y-axis is changed accordingly.

Define an offset if the signal is attenuated or amplified before it is fed into the R&S ESW so the application shows correct power results. All displayed power level results are shifted by this value.

The setting range is ± 200 dB in 0.01 dB steps.

Note, however, that the *internal* reference level (used to adjust the hardware settings to the expected signal) ignores any "Reference Level Offset". Thus, it is important to keep in mind the actual power level the R&S ESW must handle. Do not rely on the displayed reference level (internal reference level = displayed reference level - offset).

Remote command:

`DISPlay[:WINDow<n>][:SUBWindow<w>]:TRACe<t>:Y[:SCALe]:RLEVel:`
`OFFSet` on page 114

Unit ← Reference Level

The R&S ESW measures the signal voltage at the RF input.

Remote command:

`INPut:IMPedance` on page 103
`CALCulate<n>:UNIT:POWer` on page 113

Setting the Reference Level Automatically (Auto Level) ← Reference Level

Automatically determines a reference level which ensures that no overload occurs at the R&S ESW for the current input data. At the same time, the internal attenuators are adjusted. As a result, the signal-to-noise ratio is optimized, while signal compression and clipping are minimized.

To determine the required reference level, a level measurement is performed on the R&S ESW.

If necessary, you can optimize the reference level further. Decrease the attenuation level manually to the lowest possible value before an overload occurs, then decrease the reference level in the same way.

You can change the measurement time for the level measurement if necessary (see "(Meas Time Manual)" on page 79).

Remote command:

`[SENSe:]ADJust:LEVel` on page 116

Attenuation

Defines the attenuation of the signal.

You can attenuate the signal in 1 dB steps. The range is specified in the datasheet. Attenuation of less than 10 dB is only possible if you turn off [10 dB Minimum Attenuation](#).

If you are using the preamplifier in frequency ranges above 8 GHz, the available attenuation can be reduced.

The auto ranging feature in the receiver remains active even if you change the attenuation and preamplifier properties in other measurement channels and then return to the receiver application.

The R&S ESW also allows you to determine the best attenuation automatically.

- In the receiver application, turn on the "Auto Ranging" feature.
- In the other applications, select attenuation "Mode" → "Auto"

Remote command:

Global: `INPut:ATTenuation[:VALue]` on page 115

Attenuation mode: `INPut:ATTenuation:AUTO` on page 114

10 dB Minimum Attenuation

Turns the availability of attenuation levels of less than 10 dB on and off.

When you turn on this feature, the attenuation is always at least 10 dB. This minimum attenuation protects the input mixer and avoids accidental setting of 0 dB, especially if you measure EUTs with high RFI voltage.

When you turn it off, you can also select attenuation levels of less than 10 dB.

The setting applies to a manual selection of the attenuation as well as the automatic selection of the attenuation.

Remote command:

`INPut:ATTenuation:PROTection[:STATe]` on page 115

Preamplifier

Configures the preamplifier.

In addition to the standard preamplifier, a low noise amplifier is available as an optional hardware component.

- **"Off"**
Turns off the preamplifier.
- **"LN Amplifier"**
Turns on the optional low noise amplifier.
- **"Auto Preamp"**
Turns on the preamplifier (only possible when the preselector is "On").
Using both preamplifiers at the same time is not possible.

Note that if you want to use the standard preamplifier, you have to route the signal through the preselector.

For more information, see [Section 4.7.1, "Increasing measurement sensitivity \(or avoiding an input mixer overload\)"](#), on page 31.

Remote command:

Preamplifier:

State (global): `INPut:GAIN:STATE` on page 116

Low noise preamplifier:

State (global): `INPut:GAIN:LNA:STATE` on page 116

5.5 Frequency

Access: "Overview" > "Input / Frontend" > "Frequency"

The center frequency of the input signal is configured in the "Frequency" tab of the "Input/Frontend" dialog box.

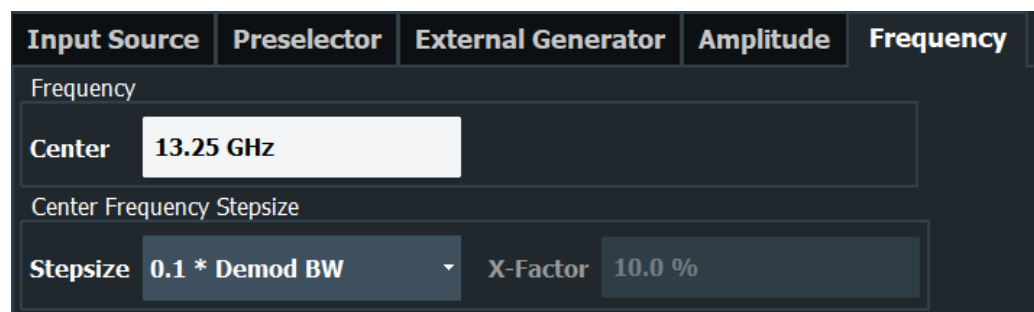

The remote commands required to configure the frequency are described in [Section 10.4.5, "Frequency configuration"](#), on page 116.

Center Frequency	52
Center Frequency Stepsize	52

Center Frequency

Defines the center frequency of the signal in Hertz.

The allowed range of values for the center frequency depends on the frequency span.

$$\text{span} > 0: \text{span}_{\min}/2 \leq f_{\text{center}} \leq f_{\max} - \text{span}_{\min}/2$$

f_{\max} and span_{\min} depend on the instrument and are specified in the specifications document.

Remote command:

`[SENSe:] FREQuency:CENTer` on page 116

Center Frequency Stepsize

Defines the step size of the center frequency. The step size can be coupled to the demodulation bandwidth, or you can set it to a fixed value manually.

"0.1 * Demod BW" (default:) Sets the step size for the center frequency to 10 % of the demodulation bandwidth.

"0.5 * Demod BW" Sets the step size for the center frequency to 50 % of the demodulation bandwidth.

"X * Demod BW"	Sets the step size for the center frequency to a manually defined factor of the demodulation bandwidth. The "X-Factor" defines the percentage of the demodulation bandwidth. Values between 1 % and 100 % in steps of 1 % are allowed. The default setting is 10 %.
"= Center"	Sets the step size to the value of the center frequency and removes the coupling of the step size to the demodulation bandwidth. The used value is indicated in the "Value" field.
"Manual"	Defines a fixed step size for the center frequency. Enter the step size in the "Value" field.

Remote command:

[\[SENSe:\] FREQuency:CENTer:STEP:LINK](#) on page 117

[\[SENSe:\] FREQuency:CENTer:STEP:LINK:FACTor](#) on page 118

[\[SENSe:\] FREQuency:CENTer:STEP](#) on page 117

5.6 Trigger configuration

Access: "Overview" > "Trigger"

Triggering means to capture the interesting part of the signal. Choosing the right trigger type and configuring all trigger settings correctly allows you to detect various incidents in your demodulated signals.

Optionally, the trigger signal used by the R&S ESW can be output to a connected device, and an external trigger signal from a connected device can be used by the R&S ESW.

For more information, refer to the description of the Spectrum application in User Manual of the R&S ESW.

- [Trigger source settings](#).....53
- [Trigger input and output settings](#).....57

5.6.1 Trigger source settings

Access: "Overview" > "Trigger" > "Trigger Source"

Trigger Source.....	54
L Free Run.....	54
L Ext. Trigger 1/2.....	54
L I/Q Power.....	54
L IF Power.....	55
L FM / AM / PM / RF (Offline).....	55
L Time.....	55
L Repetition Interval.....	55
L RF Power.....	55
Trigger Level.....	56
Trigger Offset.....	56

Hysteresis.....	56
Drop-Out Time.....	57
Slope.....	57
Trigger Holdoff.....	57

Trigger Source

In the Analog Modulation Analysis application, the next measurement can be triggered if the selected input signal exceeds the threshold specified using the "Trigger Level" setting (see "Trigger Level" on page 56). Thus, a periodic signal modulated onto the carrier frequency can be displayed. It is recommended that the measurement time covers at least five periods of the audio signal.

Remote command:

`TRIGger [: SEquence] : SOURce` on page 119

Free Run ← Trigger Source

No trigger source is considered. Data acquisition is started manually or automatically and continues until stopped explicitly.

Remote command:

`TRIGger [: SEquence] : SOURce` on page 119

Ext. Trigger 1/2 ← Trigger Source

Data acquisition starts when the TTL signal fed into the specified input connector meets or exceeds the specified trigger level.

Note: "External Trigger 1" automatically selects the trigger signal from the "TRIGGER 1 INPUT" connector on the front panel.

For details, see the "Instrument Tour" section in the R&S ESW Getting Started manual.

"External Trigger 1"

Trigger signal from the "TRIGGER 1 INPUT" connector.

"External Trigger 2"

Trigger signal from the "TRIGGER 2 INPUT / OUTPUT" connector.

Note: Connector must be configured for "Input" in the "Output" configuration

(See the R&S ESW base unit user manual).

"External Trigger 3"

Trigger signal from the "TRIGGER 3 INPUT / OUTPUT" connector on the rear panel.

Note: Connector must be configured for "Input" in the "Output" configuration.

(See R&S ESW base unit user manual).

Remote command:

`TRIGger [: SEquence] : SOURce` on page 119

I/Q Power ← Trigger Source

Triggers the measurement when the magnitude of the sampled I/Q data exceeds the trigger threshold.

The trigger bandwidth corresponds to the resolution bandwidth setting for data acquisition (see "Resolution Bandwidth" on page 60).

Remote command:

[TRIGger \[:SEquence\] :SOURce](#) on page 119

IF Power ← Trigger Source

The R&S ESW starts capturing data as soon as the trigger level is exceeded around the third intermediate frequency.

For frequency sweeps, the third IF represents the start frequency. The trigger threshold depends on the defined trigger level, as well as on the RF attenuation and preamplification. A reference level offset, if defined, is also considered. The trigger bandwidth at the intermediate frequency depends on the RBW and sweep type. For details on available trigger levels and trigger bandwidths, see the instrument specifications document.

For measurements on a fixed frequency (e.g. zero span or I/Q measurements), the third IF represents the center frequency.

This trigger source is only available for RF input.

The available trigger levels depend on the RF attenuation and preamplification. A reference level offset, if defined, is also considered.

For details on available trigger levels and trigger bandwidths, see the specifications document.

Remote command:

[TRIGger \[:SEquence\] :SOURce](#) on page 119

FM / AM / PM / RF (Offline) ← Trigger Source

Triggers when the demodulated input signal exceeds the trigger level.

Remote command:

[TRIGger \[:SEquence\] :SOURce](#) on page 119

Time ← Trigger Source

Triggers in a specified repetition interval.

See "[Repetition Interval](#)" on page 55.

Remote command:

[TRIGger \[:SEquence\] :SOURce](#) on page 119

Repetition Interval ← Trigger Source

Defines the repetition interval for a time trigger.

The shortest interval is 2 ms.

Set the repetition interval to the exact pulse period, burst length, frame length or other repetitive signal characteristic. If the required interval cannot be set with the available granularity, configure a multiple of the interval that can be set. Thus, the trigger remains synchronized to the signal.

Remote command:

[TRIGger \[:SEquence\] :TIME:RINTerval](#) on page 124

RF Power ← Trigger Source

Defines triggering of the measurement via signals which are outside the displayed measurement range.

For this purpose, the <instrument> uses a level detector at the first intermediate frequency.

The input signal must be in the frequency range between 500 MHz and 8 GHz.

The resulting trigger level at the RF input depends on the RF attenuation and preamplification. For details on available trigger levels, see the instrument's specifications document.

Note: If the input signal contains frequencies outside of this range (e.g. for fullspan measurements), the measurement can be aborted. A message indicating the allowed input frequencies is displayed in the status bar.

A "Trigger Offset", "Trigger Polarity" and "Trigger Holdoff" (to improve the trigger stability) can be defined for the RF trigger, but no "Hysteresis".

Remote command:

[TRIGger\[:SEquence\]:SOURce](#) on page 119

Trigger Level

Defines the trigger level for the specified trigger source.

For details on supported trigger levels, see the instrument specifications document.

Remote command:

[TRIGger\[:SEquence\]:LEVel:IFPower](#) on page 122

[TRIGger\[:SEquence\]:LEVel:IQPower](#) on page 123

[TRIGger\[:SEquence\]:LEVel\[:EXTernal\]](#) on page 122

[TRIGger\[:SEquence\]:LEVel:RFPower](#) on page 123

[TRIGger\[:SEquence\]:LEVel:AM:RELative](#) on page 122

[TRIGger\[:SEquence\]:LEVel:AM\[:ABSolute\]](#) on page 121

[TRIGger\[:SEquence\]:LEVel:FM](#) on page 122

[TRIGger\[:SEquence\]:LEVel:PM](#) on page 123

Trigger Offset

Defines the time offset between the trigger event and the start of the measurement.

Offset > 0:	Start of the measurement is delayed
Offset < 0:	Measurement starts earlier (pretrigger)

For the "Time" trigger source in swept measurements, this function is not available.

Remote command:

[TRIGger\[:SEquence\]:HOLDoff\[:TIME\]](#) on page 120

Hysteresis

Defines the distance in dB to the trigger level that the trigger source must exceed before a trigger event occurs. Setting a hysteresis avoids unwanted trigger events caused by noise oscillation around the trigger level.

This setting is only available for "IF Power" trigger sources. The range of the value is between 3 dB and 50 dB with a step width of 1 dB.

Remote command:

[TRIGger\[:SEquence\]:IFPower:HYSteresis](#) on page 121

Drop-Out Time

Defines the time that the input signal must stay below the trigger level before triggering again.

Remote command:

[TRIGger \[:SEQuence\] :DTIME](#) on page 120

Slope

For all trigger sources except time, you can define whether triggering occurs when the signal rises to the trigger level or falls down to it.

Remote command:

[TRIGger \[:SEQuence\] :SLOPe](#) on page 124

Trigger Holdoff

Defines the minimum time (in seconds) that must pass between two trigger events. Trigger events that occur during the holdoff time are ignored.

Remote command:

[TRIGger \[:SEQuence\] :IFPower:HOLDoff](#) on page 120

5.6.2 Trigger input and output settings

Access: "Overview" > "Trigger" > "Trigger In/Out"

[Trigger 2/3](#)..... 57

- L [Output Type](#)..... 58
 - L [Level](#)..... 58
 - L [Pulse Length](#)..... 59
 - L [Send Trigger](#)..... 59

Trigger 2/3

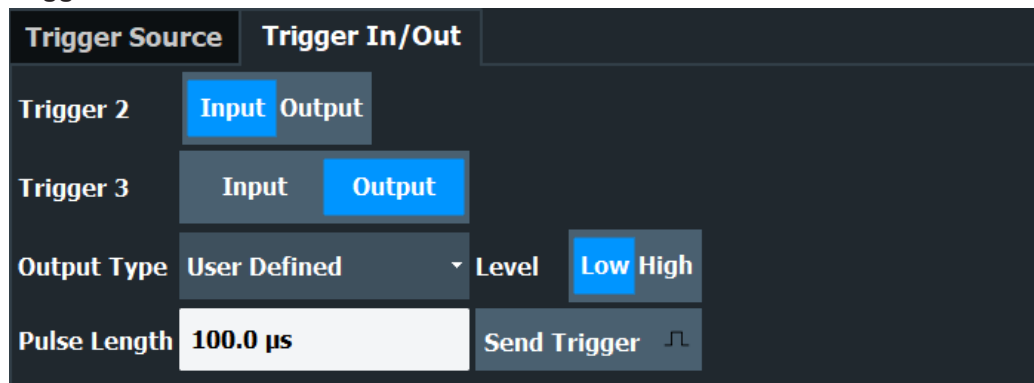

The trigger input and output functionality depends on how the variable "Trigger Input/Output" connectors are used.

Note: Providing trigger signals as output is described in detail in the R&S ESW base unit user manual.

"Trigger 1" "Trigger 1" is input only.

"Trigger 2"	Defines the usage of the variable "Trigger Input/Output" connector on the front panel
"Trigger 3"	Defines the usage of the variable "Trigger 3 Input/Output" connector on the rear panel
"Input"	The signal at the connector is used as an external trigger source by the R&S ESW. Trigger input parameters are available in the "Trigger" dialog box.
"Output"	The R&S ESW sends a trigger signal to the output connector to be used by connected devices. Further trigger parameters are available for the connector. Note: For offline AF or RF triggers, no output signal is provided.

Remote command:

[OUTPut:TRIGger<tp>:DIRection](#) on page 111

Output Type ← Trigger 2/3

Type of signal to be sent to the output

"Device Triggered"	(Default) Sends a trigger when the R&S ESW triggers.
"Trigger Armed"	Sends a (high level) trigger when the R&S ESW is in "Ready for trigger" state. This state is indicated by a status bit in the <code>STATUS:OPERation</code> register (bit 5), as well as by a low-level signal at the "AUX" port (pin 9). For details, see the description of the <code>STATUS:OPERation</code> register in the R&S ESW base unit user manual and the description of the "AUX" port in the R&S ESW Getting Started manual.
"User Defined"	Sends a trigger when you select "Send Trigger". In this case, further parameters are available for the output signal.

Remote command:

[OUTPut:TRIGger<tp>:OTYPe](#) on page 111

Level ← Output Type ← Trigger 2/3

Defines whether a high (1) or low (0) constant signal is sent to the trigger output connector (for "Output Type": "User Defined").

The trigger pulse level is always opposite to the constant signal level defined here. For example, for "Level" = "High", a constant high signal is output to the connector until you select the [Send Trigger](#) function. Then, a low pulse is provided.

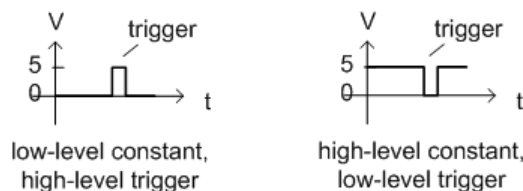

Remote command:

[OUTPut:TRIGger<tp>:LEVel](#) on page 111

Pulse Length ← Output Type ← Trigger 2/3

Defines the duration of the pulse (pulse width) sent as a trigger to the output connector.

Remote command:

[OUTPut:TRIGger<tp>:PULSe:LENGth](#) on page 112

Send Trigger ← Output Type ← Trigger 2/3

Sends a user-defined trigger to the output connector immediately.

Note that the trigger pulse level is always opposite to the constant signal level defined by the output [Level](#) setting. For example, for "Level" = "High", a constant high signal is output to the connector until you select the "Send Trigger" function. Then, a low pulse is sent.

Which pulse level is sent is indicated by a graphic on the button.

Remote command:

[OUTPut:TRIGger<tp>:PULSe:IMMediate](#) on page 112

5.7 Bandwidth settings

Access: "Overview" > "Data Acquisition" > "Bandwidth" tab

The bandwidth settings define which parts of the input signal are acquired and then demodulated.

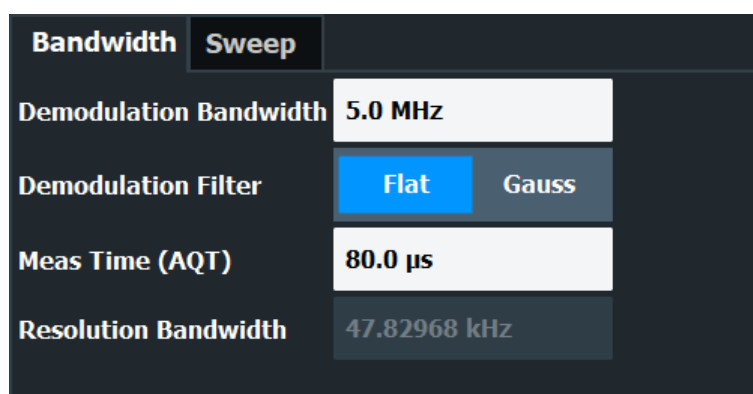

Demodulation Bandwidth	59
Demodulation Filter	60
Measurement Time (AQT)	60
Resolution Bandwidth	60

Demodulation Bandwidth

Defines the demodulation bandwidth of the measurement. The demodulation bandwidth determines the sample rate with which the input signal is captured and analyzed.

For recommendations on finding the correct demodulation bandwidth, see [Section 4.2, "Demodulation bandwidth"](#), on page 26.

For details on the relation between demodulation bandwidth and sample rate, refer to [Section 4.3, "Sample rate and demodulation bandwidth"](#), on page 27.

Remote command:

[SENSe:] BWIDth:DEMod on page 133

Demodulation Filter

Defines the filter to be used for demodulation.

For details on sample rates, measurement times and trigger offsets for various demodulation bandwidths when using a Gaussian filter, see [Section 4.3, "Sample rate and demodulation bandwidth"](#), on page 27.

"Flat" Default

"Gauss" Optimizes the settling behavior of the filter

Remote command:

[SENSe:] BWIDth:DEMod:TYPE on page 133

Measurement Time (AQT)

Defines how long data is acquired for demodulation.

Remote command:

[SENSe:] ADEMod:MTIME on page 131

Resolution Bandwidth

Defines the resolution bandwidth for data acquisition. The available range is defined in the specifications document.

Remote command:

[SENSe:] BANDwidth[:RESolution] on page 134

5.8 Sweep settings

Access: "Overview" > "Data Acquisition" > "Sweep" tab

The sweep settings define how often data from the input signal is acquired and then demodulated.

Bandwidth	Sweep
Meas Time (AQT)	80.0 µs
Sweep Points	1001
Sweep Count	0
Specifics for	1: FM Time Domain

Continuous Sweep / Run Cont.....	61
Single Sweep / Run Single.....	61
Continue Single Sweep.....	61

Measurement Time (AQT).....	62
Sweep Points.....	62
Sweep/Average Count.....	62

Continuous Sweep / Run Cont

After triggering, starts the sweep and repeats it continuously until stopped. This is the default setting.

While the measurement is running, "Continuous Sweep" and [RUN CONT] are highlighted. The running measurement can be aborted by selecting the highlighted softkey or key again. The results are not deleted until a new measurement is started.

Note: Sequencer. If the Sequencer is active, "Continuous Sweep" only controls the sweep mode for the currently selected channel. However, the sweep mode only takes effect the next time the Sequencer activates that channel, and only for a channel-defined sequence. In this case, a channel in continuous sweep mode is swept repeatedly.

Furthermore, [RUN CONT] controls the Sequencer, not individual sweeps. [RUN CONT] starts the Sequencer in continuous mode.

For details on the Sequencer, see the R&S ESW base unit user manual.

Remote command:

Measurement mode: [INITiate<n>:CONTinuous](#) on page 129

Run measurement: [INITiate<mt>\[:IMMediate\]](#) on page 130

Single Sweep / Run Single

After triggering, starts the number of sweeps set in "Sweep Count". The measurement stops after the defined number of sweeps has been performed.

While the measurement is running, "Single Sweep" and [RUN SINGLE] are highlighted. The running measurement can be aborted by selecting the highlighted softkey or key again.

Note: Sequencer. If the Sequencer is active, "Single Sweep" only controls the sweep mode for the currently selected channel. However, the sweep mode only takes effect the next time the Sequencer activates that channel, and only for a channel-defined sequence. In this case, the Sequencer sweeps a channel in single sweep mode only once.

Furthermore, [RUN SINGLE] controls the Sequencer, not individual sweeps. [RUN SINGLE] starts the Sequencer in single mode.

If the Sequencer is off, only the evaluation for the currently displayed channel is updated.

For details on the Sequencer, see the R&S ESW base unit user manual.

Remote command:

Measurement mode: [INITiate<n>:CONTinuous](#) on page 129

Run measurement: [INITiate<mt>\[:IMMediate\]](#) on page 130

Continue Single Sweep

After triggering, repeats the number of sweeps set in "Sweep Count", without deleting the trace of the last measurement.

While the measurement is running, "Continue Single Sweep" and [RUN SINGLE] are highlighted. The running measurement can be aborted by selecting the highlighted softkey or key again.

Remote command:

[INITiate<n>:CONMeas](#) on page 129

Measurement Time (AQT)

Defines how long data is acquired for demodulation.

Remote command:

[\[SENSe:\]ADEMod:MTIME](#) on page 131

Sweep Points

Defines the number of measured values to be collected during one sweep.

All values from 101 to 100001 can be set. The default value is 1001 sweep points.

The R&S ESW supports values between 101 and 100001. Zero span measurements support up to 1,000,001 sweep points (multiple traces) or 10,000,001 (one trace).

Remote command:

[\[SENSe:\]SWEep\[:WINDow<n>\]:POINTs](#) on page 135

Sweep/Average Count

Defines the number of measurements to be performed in the single sweep mode. Values from 0 to 200000 are allowed. If the values 0 or 1 are set, one measurement is performed.

The sweep count is applied to all the traces in all diagrams.

If the trace modes "Average", "Max Hold" or "Min Hold" are set, this value also determines the number of averaging or maximum search procedures.

In continuous sweep mode, if "Sweep Count" = 0 (default), averaging is performed over 10 measurements. For "Sweep Count" = 1, no averaging, maxhold or minhold operations are performed.

Remote command:

[\[SENSe:\]SWEep:COUNT](#) on page 134

5.9 Demodulation

Access: "Overview" > "Demod Settings"

Or: "Meas Setup" > "Demod"

- [Basic demodulation measurement parameters \(Demod\)](#).....63
- [Demodulation spectrum](#).....65
- [AF filter](#).....68
- [Scaling](#).....71
- [Units](#).....75
- [Result table settings](#).....75

5.9.1 Basic demodulation measurement parameters (Demod)

Access: "Overview" > "Demod Settings" > "Demod"

Or: "Meas Setup" > "Demod" > "Demod" tab

The basic demodulation measurement parameters define how the measurement is performed.

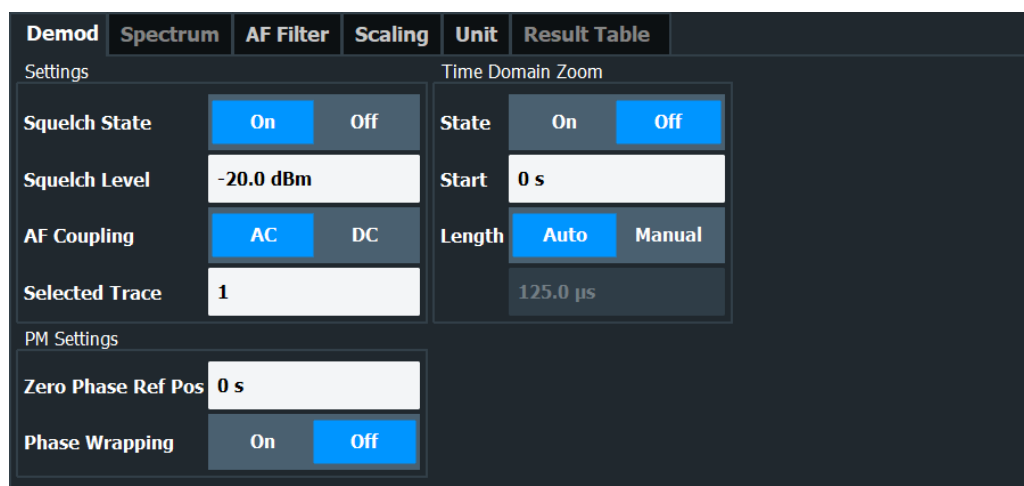

Squelch State.....63
 Squelch Level.....63
 AF Coupling.....64
 Selected Trace.....64
 Time Domain Zoom.....64
 L State.....64
 L Start.....65
 L Length.....65
 L Time per Division.....65
 Phase Wrap On/Off (PM Time Domain only).....65

Squelch State

Activates the squelch function, that is: if the signal falls below a defined threshold, the demodulated data is automatically set to 0. This is useful, for example, to avoid demodulation noise during transmission breaks.

This function is only available for FM demodulation.

Remote command:

[SENSe:]ADEMod:SQUelch[:STATe] on page 137

Squelch Level

Defines the level threshold below which the demodulated data is set to 0 if squelching is enabled. The squelch level is an absolute value.

Remote command:

[SENSe:]ADEMod:SQUelch:LEVel on page 137

AF Coupling

Controls the automatic correction of the frequency offset and phase offset of the input signal:

This function is only available for FM or PM time domain evaluations.

- FM time evaluation
 - If DC is selected, the absolute frequency is displayed. That means, an input signal with an offset relative to the center frequency is not displayed symmetrically to the zero line.
 - If AC is selected, the frequency offset is automatically corrected, i.e. the trace is always symmetric to the zero line.
- PM time evaluation
 - If DC is selected, the phase runs according to the existing frequency offset. In addition, the DC signal contains a phase offset of $\pm \pi$.
 - If AC is selected, the frequency offset and phase offset are automatically corrected, i.e. the trace is always symmetric to the zero line.

Remote command:

[\[SENSe:\]ADEMod<n>:AF:COUPling](#) on page 136

Selected Trace

Defines the trace used to determine the results in the "Result Summary".

Time Domain Zoom

Using the time domain zoom, the demodulated data for a particular time span is extracted and displayed in more detail. Time domain zoom is useful if the measurement time is very large and thus each sweep point represents a large time span. The time domain zoom function distributes the available sweep points only among the time span defined by the zoom area length. The time span displayed per division of the diagram is decreased. Thus, the display of the extracted time span becomes more precise. Note that the time domain zoom area affects not only the diagram display, but the entire evaluation for the current window.

This function is only available for evaluations in the time domain.

Tip: In addition to the Time Domain Zoom, a graphical zoom is available for all diagram evaluations. However, the graphical zoom is useful only if more measured values than trace points are available. The (time) span represented by each measurement point remains the same.

For details see the R&S ESW User Manual.

State ← Time Domain Zoom

Activates or deactivates the time domain zoom mode.

- | | |
|-------|--|
| "On" | Activates the time domain zoom. |
| "Off" | Deactivates the time domain zoom and restores the original display. If more measured values than measurement points are available, several measured values are combined in one measurement point according to the method of the selected trace detector.
For details on detectors refer to the R&S ESW User Manual. |

Remote command:

[\[SENSe:\]ADEMod<n>:ZOOM\[:STATe\]](#) on page 140

Start ← Time Domain Zoom

Defines the start time for the time domain zoom area. For spectrum evaluations, the start time is always 0.

Remote command:

[SENSe:] ADEMod<n>: ZOOM: START on page 139

Length ← Time Domain Zoom

Defines the length of the time domain zoom area. Enter the length as a time value manually, or use the "Auto" setting to set the length to the current number of sweep points automatically.

Remote command:

[SENSe:] ADEMod<n>: ZOOM: LENGTH on page 138

[SENSe:] ADEMod<n>: ZOOM: LENGTH: MODE on page 139

Time per Division ← Time Domain Zoom

Enables the "Time Domain Zoom" function and defines the zoom area length in one step. The width of the zoom display is divided into 10 divisions; thus, by entering the time that is displayed in each division, you indirectly define the zoom area length ("Time per Division" * 10). The starting point of the zoom area is determined automatically. To specify the starting point manually, use the [Start](#) setting.

"Time per Division" is available from the main "AM FM PM Analog Demod" menu.

Phase Wrap On/Off (PM Time Domain only)

Activates/deactivates the phase wrap.

On	The phase is displayed in the range $\pm 180^\circ$ ($\pm \Pi$). For example, if the phase exceeds $+180^\circ$, 360° is subtracted from the phase value, with the display thus showing $>-180^\circ$.
Off	The phase is not wrapped.

This setting is only available for PM time domain displays with DC coupling.

Remote command:

CALC: FORM PHAS/CALC: FORM UPH, see [CALCulate<n>: FORMat](#) on page 138

5.9.2 Demodulation spectrum

Access: "Overview" > "Demod Settings" > "Spectrum"

Or: "Meas Setup" > "Demod" > "Spectrum" tab

The demodulation spectrum defines which span of the demodulated data is evaluated.

Depending on the evaluation (AF or RF display), the settings vary.

- [AF evaluation](#)..... 65
- [RF evaluation](#)..... 67

5.9.2.1 AF evaluation

Access: "Overview" > "Demod Settings" > "Spectrum"

Or: "Meas Setup" > "Demod" > "Spectrum" tab

These settings are only available for AF Spectrum evaluations, not in the time domain.



AF Center.....	66
AF Start.....	66
AF Stop.....	66
AF Span.....	66
AF Full Span.....	66

AF Center

Defines the center frequency of the demodulated data to evaluate.

Remote command:

[\[SENSe:\]ADEMod:AF:CENTer](#) on page 142

AF Start

Defines the start frequency of the demodulated data to evaluate.

Remote command:

[\[SENSe:\]ADEMod:AF:START](#) on page 143

AF Stop

Defines the stop frequency of the demodulated data to evaluate.

The maximum AF stop frequency corresponds to half the demodulation bandwidth.

Remote command:

[\[SENSe:\]ADEMod:AF:STOP](#) on page 143

AF Span

Defines the span (around the center frequency) of the demodulated data to evaluate.

The maximum span is DBW/2.

Remote command:

[\[SENSe:\]ADEMod:AF:SPAN](#) on page 142

AF Full Span

Sets the span (around the center frequency) of the demodulated data to the maximum of DBW/2.

Remote command:

[\[SENSe:\]ADEMod:AF:SPAN:FULL](#) on page 142

5.9.2.2 RF evaluation

Access: "Overview" > "Demod Settings" > "Spectrum"

Or: "Meas Setup" > "Demod" > "Spectrum" tab

These settings are only available for RF evaluation, both in time and frequency domain. Note that for RF data the center frequency and demodulation bandwidth correspond to the settings defined in the "Input" and "Data Acquisition" configuration.

Demod	Spectrum	Scaling	Unit	Result Table
Center		15.0 MHz		
Span		5.0 MHz		
Demodulation Bandwidth		5.0 MHz		
		RF Full Span (=DBW)		

Center Frequency.....	67
Span.....	67
Demodulation Bandwidth.....	68
RF Full Span.....	68

Center Frequency

Defines the center frequency of the signal in Hertz.

The allowed range of values for the center frequency depends on the frequency span.

$$\text{span} > 0: \text{span}_{\min}/2 \leq f_{\text{center}} \leq f_{\text{max}} - \text{span}_{\min}/2$$

f_{max} and span_{\min} depend on the instrument and are specified in the specifications document.

Remote command:

[SENSe:] FREQuency:CENTer on page 116

Span

Defines the frequency span. The center frequency is kept constant. The following range is allowed:

$$\text{span} = 0: 0 \text{ Hz}$$

$$\text{span} > 0:$$

$$\text{span}_{\min} \leq f_{\text{span}} \leq f_{\text{max}}$$

$$\text{and } f_{\text{max}} = \text{DBW}/2$$

f_{max} and span_{\min} are specified in the specifications document.

Remote command:

[SENSe:] ADEMod: SPECTrum: SPAN[:MAXimum] on page 144

[SENSe:] ADEMod: SPECTrum: SPAN: ZOOM on page 143

Demodulation Bandwidth

Defines the demodulation bandwidth of the measurement. The demodulation bandwidth determines the sample rate with which the input signal is captured and analyzed.

For recommendations on finding the correct demodulation bandwidth, see [Section 4.2, "Demodulation bandwidth"](#), on page 26.

For details on the relation between demodulation bandwidth and sample rate, refer to [Section 4.3, "Sample rate and demodulation bandwidth"](#), on page 27.

Remote command:

[SENSe:] BWIDth:DEMod on page 133

RF Full Span

Sets the span (around the center frequency) of the RF data to be evaluated to the demodulation bandwidth.

Remote command:

[SENSe:] ADEMod:SPECTrum:SPAN[:MAXimum] on page 144

5.9.3 AF filter

Access: "Overview" > "Demod Settings" > "AF Filter"

Or: "Meas Setup" > "Demod" > "AF Filter" tab

The AF filter reduces the evaluated bandwidth of the demodulated signal and can define a weighting function.



AF filters are only available for AF evaluations, not for RF evaluation.

Demod	Spectrum	AF Filter	Scaling	Unit	Result Table
High Pass	Low Pass	Weighting	Deemphasis		
None	None	None	None		
All Filters Off					

High Pass	68
Low Pass	69
Weighting	69
Deemphasis	70
Deactivating all AF Filters	71

High Pass

Defines a high pass filter with the given limit to separate the DC component. The filters are indicated by the 3 dB cutoff frequency. The 50 Hz and 300 Hz filters are designed as 2nd-order Butterworth filter (12 dB/octave). The 20 Hz filter is designed as 3rd-order Butterworth filter (18 dB/octave).

The high pass filters are active in the following demodulation bandwidth range:

None	No AF Filter used (default)
20 Hz	100 Hz ≤ demodulation bandwidth ≤ 1.6 MHz
50 Hz:	200 Hz ≤ demodulation bandwidth ≤ 3 MHz
300 Hz:	800 Hz ≤ demodulation bandwidth ≤ 8 MHz
Manual:	A high pass filter with the manually defined frequency is used.

Note: When you are using one of the [signal outputs](#), selecting the high pass filter is not possible.

Remote command:

[\[SENSe:\] FILTER<n>:HPASs\[:STATe\]](#) on page 148

[\[SENSe:\] FILTER<n>:HPASs:FREQuency\[:ABSolute\]](#) on page 147

[\[SENSe:\] FILTER<n>:HPASs:FREQuency:MANual](#) on page 147

Low Pass

Defines a low pass filter type. Relative and absolute low pass filter are available.

- Absolute low pass filters:
Absolute filters are indicated by the 3 dB cutoff frequency. The 3 kHz, 15 kHz and 23 kHz filters are designed as 5th-order Butterworth filters (30 dB/octave). The 150 kHz filter is designed as 8th-order Butterworth filter (48 dB/octave).
The absolute low pass filters are active in the following demodulation bandwidth range:

Filter type	Demodulation bandwidth
3 kHz:	6.4 kHz ≤ demodulation bandwidth ≤ 3 MHz
15 kHz:	50 kHz ≤ demodulation bandwidth ≤ 8 MHz
23 kHz	50 kHz ≤ demodulation bandwidth ≤ 18 MHz
150 kHz:	400 kHz ≤ demodulation bandwidth ≤ 8 MHz
Manual:	A low pass filter with the manually defined frequency is used.

Note: When you are using one of the [signal outputs](#), you can only select the low pass filter. High pass filters are not available in that case.

- Relative low pass filters:
Relative filters (3 dB) can be selected in % of the demodulation bandwidth. The filters are designed as 5th-order Butterworth filter (30 dB/octave) and active for all demodulation bandwidths.
- "NONE" deactivates the AF low pass filter (default).

Remote command:

[\[SENSe:\] FILTER<n>:LPASs\[:STATe\]](#) on page 149

[\[SENSe:\] FILTER<n>:LPASs:FREQuency\[:ABSolute\]](#) on page 148

[\[SENSe:\] FILTER<n>:LPASs:FREQuency:RELative](#) on page 149

[\[SENSe:\] FILTER<n>:LPASs:FREQuency:MANual](#) on page 148

Weighting

Selects a weighting AF filter. By default, no weighting filter is active.

"A weighted"	Switches on the A weighted filter. The weighting filter is active in the following demodulation bandwidth range: 100 kHz ≤ demodulation bandwidth ≤ 800 kHz
"CCITT"	Switches on a CCITT P.53 weighting filter. The weighting filter is active in the following demodulation bandwidth range: 20 kHz ≤ demodulation bandwidth ≤ 3 MHz
"CCIR weighed"	Switches on the CCIR weighted filter. The weighting filter is active in the following demodulation bandwidth range: 100 kHz ≤ demodulation bandwidth ≤ 3.0 MHz
"CCIR unweighted"	Switches on the CCIR unweighted filter, which is the combination of the 20 Hz highpass and 23 kHz low pass filter. The weighting filter is active in the following demodulation bandwidth range: 50 kHz ≤ demodulation bandwidth ≤ 1.6 MHz

Remote command:

[SENSe:] FILTer<n>:CCITt[:STATe] on page 146

[SENSe:] FILTer<n>:CCIR[:UNWeighted][:STATe] on page 145

[SENSe:] FILTer<n>:CCIR:WEIGhted[:STATe] on page 145

[SENSe:] FILTer<n>:AWEIGhted[:STATe] on page 144

Deemphasis

Activates a deemphasis filter with the given time constant.

Sometimes a modulated signal is extorted by a pre-emphasis filter before transmission, for example to eliminate frequencies that are more prone to interferences. In this case, the emphasis function must be reversed after demodulation, which is done by the deemphasis filter.

The deemphasis filter is active in the following demodulation bandwidth range:

25 μs:	25 kHz ≤ demodulation bandwidth ≤ 40 MHz
50 μs:	6.4 kHz ≤ demodulation bandwidth ≤ 18 MHz
75 μs:	6.4 kHz ≤ demodulation bandwidth ≤ 18 MHz
750 μs:	800 Hz ≤ demodulation bandwidth ≤ 3 MHz

Depending on the deemphasis filter, a minimum demodulation bandwidth is required for an error less than 0.5 dB, up to a maximum AF frequency. The following table shows the dependencies.

Deemphasis [us]	25 μs	50 μs	75 μs	750 μs
Max. AF frequency	25 kHz	12 kHz	8 kHz	800 Hz
Required demodulation bandwidth	≥ 200 kHz	≥ 100 kHz	≥ 50 kHz	≥ 6.4 kHz

For higher AF frequencies, you must increase the demodulation bandwidth.

Remote command:

[SENSe:] FILTer<n>:DEMPhasis[:STATe] on page 146

[SENSe:] FILTer<n>:DEMPhasis:TCONstant on page 146

Deactivating all AF Filters

"All Filter Off" deactivates all AF filters for the selected evaluation.

Remote command:

[SENSe:] FILTer<n>:AOFF on page 145

5.9.4 Scaling

Access: "Overview" > "Demod Settings" > "Scaling"

Or: "Meas Setup" > "Demod" > "Scaling" tab

The scaling parameters define the range of the demodulated data to be displayed.

- [AF evaluation](#).....71
- [RF evaluation](#).....73

5.9.4.1 AF evaluation

Access: "Overview" > "Demod Settings" > "Scaling"

Or: "Meas Setup" > "Demod" > "Scaling" tab

These settings are only available for AF evaluations.

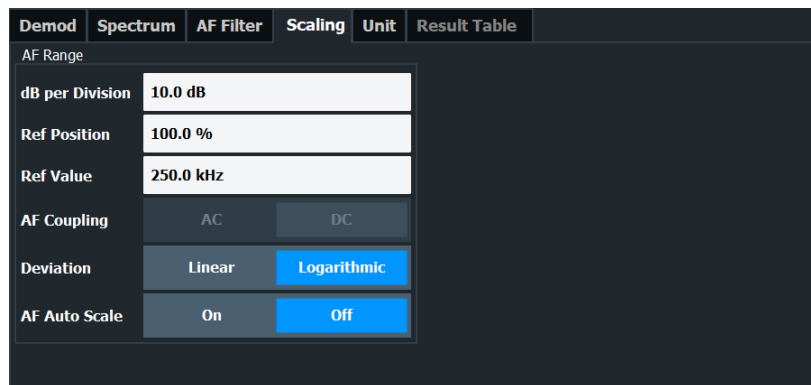

[Dev per Division/ dB per Division](#).....71

[Reference Value Position](#).....72

[Reference Value](#).....72

[AF Coupling](#).....72

[Deviation](#).....73

[AF Auto Scale](#).....73

Dev per Division/ dB per Division

Defines the modulation depth or the phase deviation or frequency deviation per division (logarithmic: 0.1 dB to 20 dB):

AM display:	0.0001 % to 1000 %
FM display:	1 Hz/div to 500 MHz/div
PM display:	0.0001 rad/div to 1000 rad/div

Note: The value defined per division refers to the default display of 10 divisions on the y-axis. If fewer divisions are displayed (e.g. because the window is reduced in height), the range per division is increased. Thus, the same result range is displayed in the smaller window. In this case, the per division value does not correspond to the actual display.

Remote command:

`DISPlay[:WINDow<n>][:SUBWindow<w>]:TRACe<t>:Y[:SCALe]:PDIVision`
on page 140

Reference Value Position

Determines the position of the reference value for the modulation depth or the phase deviation or frequency deviation on the y-axis of the diagram.

The position is entered as a percentage of the diagram height with 100 % corresponding to the upper diagram border. The default setting is 50 % (diagram center) for the AF time evaluations and 100 % (upper diagram border) for the AF spectrum evaluations.

Remote command:

`DISPlay[:WINDow<n>][:SUBWindow<w>]:TRACe<t>:Y[:SCALe]:RPOSition`
on page 141

Reference Value

Determines the modulation depth or the phase deviation or the frequency deviation at the reference line of the y-axis. The reference value can be set specifically for each evaluation.

- AF time display
The trace display takes individual frequency/phase offsets into account (in contrast, the **AF Coupling** setting permits automatic correction by the average frequency/phase offset of the signal, and therefore cannot be activated simultaneously).
- AF spectrum display
In the default setting, the reference value defines the modulation depth or the FM/PM deviation at the upper diagram border.

Possible values:

- AM: 0 and ± 10000 %
- FM: 0 and ± 10 MHz
- PM: 0 and ± 10000 rad

Note: The reference value for the AF range in the **window title bar** is displayed with respect to the defined reference *position*. The position can vary for different windows. For time domain and frequency domain windows, for example, a different reference value can be displayed, although the same reference is actually used (but the positions vary).

Remote command:

`DISPlay[:WINDow<n>][:SUBWindow<w>]:TRACe<t>:Y[:SCALe]:RVALue`
on page 150

AF Coupling

Controls the automatic correction of the frequency offset and phase offset of the input signal:

This function is only available for FM or PM time domain evaluations.

- FM time evaluation
If DC is selected, the absolute frequency is displayed. That means, an input signal with an offset relative to the center frequency is not displayed symmetrically to the zero line.
If AC is selected, the frequency offset is automatically corrected, i.e. the trace is always symmetric to the zero line.
- PM time evaluation
If DC is selected, the phase runs according to the existing frequency offset. In addition, the DC signal contains a phase offset of $\pm \pi$.
If AC is selected, the frequency offset and phase offset are automatically corrected, i.e. the trace is always symmetric to the zero line.

Remote command:

[\[SENSe:\]ADEMod<n>:AF:COUPLing](#) on page 136

Deviation

Switches between logarithmic and linear display of the modulation depth or the phase deviation or the frequency deviation.

Remote command:

[DISPlay\[:WINDow<n>\]\[:SUBWindow<w>\]:TRACe<t>:Y:SPACing](#) on page 141

AF Auto Scale

Activates automatic scaling of the y-axis for AF measurements. RF power and RF spectrum measurements are not affected by the auto-scaling.

Remote command:

[\[SENSe:\]ADJust:SCALE\[:Y\]:AUTO\[:CONTinuous\]](#) on page 127

5.9.4.2 RF evaluation

Access: "Overview" > "Demod Settings" > "Scaling"

Or: "Meas Setup" > "Demod" > "Scaling" tab

These settings are only available for RF evaluations and the "result summary".

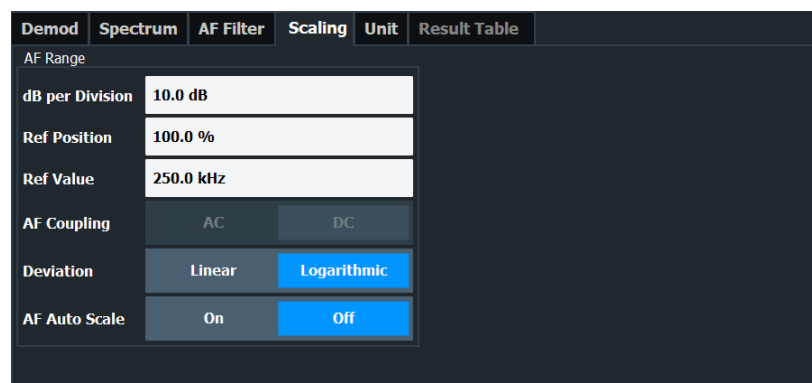

Range.....	74
Ref Level Position.....	74
Auto Scale Once.....	74
Scaling.....	74

Range

Defines the displayed y-axis range in dB.

The default value is 100 dB.

For Analog Modulation Analysis measurements, time domain scaling is defined in Hz (default: 500 kHz).

Remote command:

`DISPlay[:WINDow<n>][:SUBWindow<w>]:TRACe<t>:Y[:SCALe]` on page 151

Ref Level Position

Defines the reference level position, i.e. the position of the maximum AD converter value on the level axis in %.

0 % corresponds to the lower and 100 % to the upper limit of the diagram.

Values from -120 % to +280 % are available.

Larger values are useful for small scales, such as a power range of 10 dB or 20 dB, and low signal levels, for example 60 dB below the reference level. In this case, large reference level position values allow you to see the trace again.

Only available for RF measurements.

Remote command:

`DISPlay[:WINDow<n>][:SUBWindow<w>]:TRACe<t>:Y[:SCALe]:RPOSition` on page 141

Auto Scale Once

Automatically determines the optimal range and reference level position to be displayed for the current measurement settings.

The display is only set once; it is not adapted further if the measurement settings are changed again.

Remote command:

`DISPlay[:WINDow<n>][:SUBWindow<w>]:TRACe<t>:Y[:SCALe]:AUTO ONCE` on page 151

Scaling

Defines the scaling method for the y-axis.

"Logarithmic"	Logarithmic scaling (only available for logarithmic units - dB..., and A, V, Watt)
"Linear with Unit"	Linear scaling in the unit of the measured signal
"Linear Percent"	Linear scaling in percentages from 0 to 100
"Absolute"	The labeling of the level lines refers to the absolute value of the reference level (not available for "Linear Percent")

"Relative" The scaling is in dB, relative to the reference level (only available for logarithmic units - dB...). The upper line of the grid (reference level) is always at 0 dB.

Remote command:

`DISPlay[:WINDow<n>][:SUBWindow<w>]:TRACe<t>:Y:SPACing` on page 141
`DISPlay[:WINDow<n>][:SUBWindow<w>]:TRACe<t>:Y[:SCALE]:MODE`
 on page 151

5.9.5 Units

Access: "Overview" > "Demod Settings" > "Unit"

Or: "Meas Setup" > "Demod" > "Unit" tab

The units define how the demodulated data is displayed.

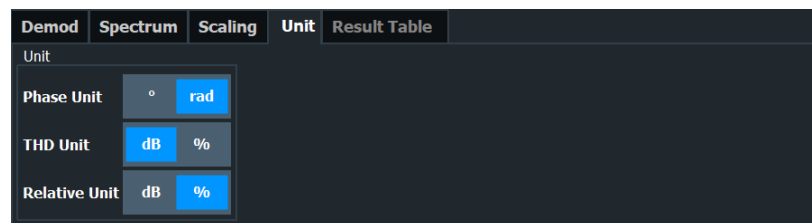

Phase Unit (Rad/Deg)	75
THD Unit (%/ DB)	75
Relative Unit	75

Phase Unit (Rad/Deg)

Sets the phase unit to rad or deg for displaying PM signals.

Remote command:

`UNIT<n>:ANGLE` on page 152

THD Unit (%/ DB)

Sets the unit to percent or DB for the calculation of the THD (in the "Result Summary").

Remote command:

`UNIT<n>:THD` on page 152

Relative Unit

Defines the unit for relative demodulation results (see [Section 5.9.6, "Result table settings"](#), on page 75).

Remote command:

`CONFigure:ADEMod:RESults:UNIT` on page 155

5.9.6 Result table settings

Access: "Overview" > "Demod Settings" > "Result Table"

Or: "Meas Setup" > "Demod" > "Result Table" tab

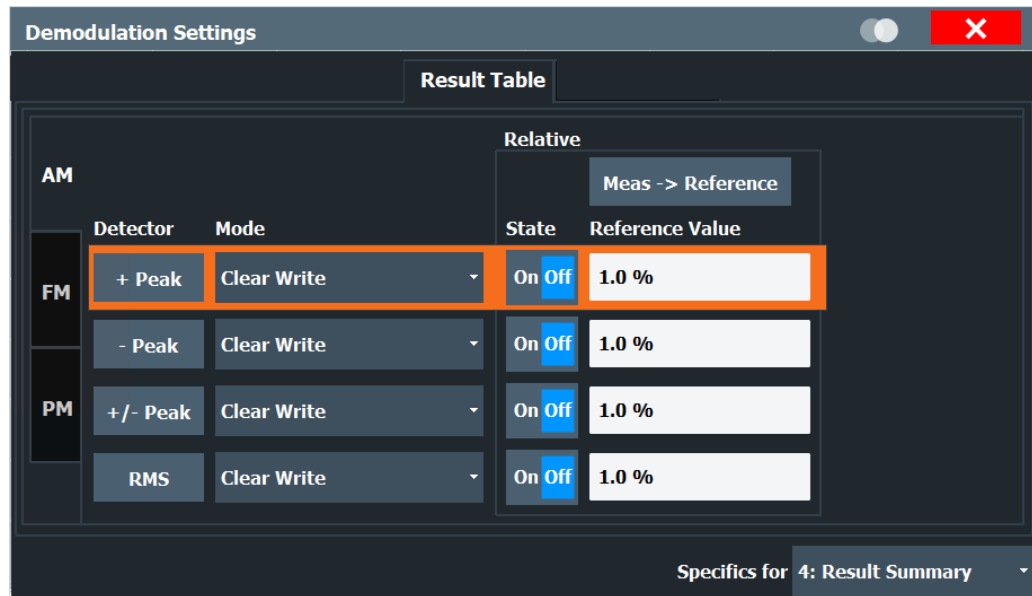

The demodulation results are displayed in the "Result Summary" table (see also "Result Summary" on page 21). The detectors used to determine the results can be configured.

In addition to common absolute demodulation, the Analog Modulation Analysis application also provides demodulation results relative to user-defined or measured reference values in the "Result Summary".

The settings for the "Result Summary" can be defined individually for the different modulation types (FM, AM, PM). For each modulation type, a separate tab is provided in the dialog box.

Detector.....	76
Mode.....	76
State.....	77
Reference Value.....	77
Meas -> Reference.....	77

Detector

Detector type for demodulation results

"+ Peak"	Positive peak
"- Peak"	Negative peak
"+/- Peak"	Autopick
"RMS"	Root mean square

Remote command:

The detector is specified by the `DETECTOR<det>` suffix in `CONFIGURE:RELATIVE:AM|FM|PM:DETECTOR<det>... commands`.

Mode

Defines the mode with which the demodulation result is determined.

- "Clear Write" Overwrite mode: the detector value is overwritten by each sweep. This is the default setting.
- "Max Hold" The maximum value is determined over several sweeps and displayed. The R&S ESW saves each result only if the new value is greater than the previous one.
- "Average" The average result is determined over all sweeps.

Remote command:

[CONFigure:ADEMod:RESults:AM:DETEctor<det>:MODE](#) on page 154

[CONFigure:ADEMod:RESults:FM:DETEctor<det>:MODE](#) on page 154

[CONFigure:ADEMod:RESults:PM:DETEctor<det>:MODE](#) on page 154

State

Activates relative demodulation for the selected detector. If activated, the demodulated result is set in relation to the [Reference Value](#).

Remote command:

[CONFigure:ADEMod:RESults:AM:DETEctor<det>:STATE](#) on page 153

[CONFigure:ADEMod:RESults:FM:DETEctor<det>:STATE](#) on page 153

[CONFigure:ADEMod:RESults:PM:DETEctor<det>:STATE](#) on page 153

Reference Value

Defines the reference value to be used for relative demodulation results and recalculates the results. If necessary, the detector is activated.

Note: A reference value 0 would provide infinite results and is thus automatically corrected to 0.1.

Remote command:

[CONFigure:ADEMod:RESults:AM:DETEctor<det>:REFerence](#) on page 153

[CONFigure:ADEMod:RESults:FM:DETEctor<det>:REFerence](#) on page 153

[CONFigure:ADEMod:RESults:PM:DETEctor<det>:REFerence](#) on page 153

Meas -> Reference

Sets the [Reference Value](#) to be used for relative demodulation results to the currently measured value *for all relative detectors*.

Note: A reference value 0 would provide infinite results and is thus automatically corrected to 0.1.

If necessary, the detectors are activated.

Remote command:

[CONFigure:ADEMod:RESults:AM:DETEctor<det>:REFerence:MEASStoref<t>](#)
on page 154

[CONFigure:ADEMod:RESults:FM:DETEctor<det>:REFerence:MEASStoref<t>](#)
on page 154

[CONFigure:ADEMod:RESults:PM:DETEctor<det>:REFerence:MEASStoref<t>](#)
on page 154

5.10 Demodulation display



Access: "Overview" > "Demod/Display"

The demodulated signal can be displayed using various evaluation methods. All evaluation methods available for the Analog Modulation Analysis application are displayed in the evaluation bar in SmartGrid mode when you do one of the following:

Up to six evaluation methods can be displayed simultaneously in separate windows. The Analog Modulation Analysis evaluation methods are described in [Section 3, "Measurements and result displays"](#), on page 13.



For details on working with the SmartGrid, see the R&S ESW Getting Started manual.

5.11 Automatic settings

Access: [AUTO SET]

Some settings can be adjusted by the R&S ESW automatically according to the current measurement settings.

The remote commands required for automatic configuration are described in [Section 10.4.7, "Automatic configuration"](#), on page 124.

Adjusting all Determinable Settings Automatically (Auto All).....	78
Adjusting the Center Frequency Automatically (Auto Frequency).....	78
Setting the Reference Level Automatically (Auto Level).....	79
Resetting the Automatic Measurement Time (Meas Time Auto).....	79
(Meas Time Manual).....	79
Upper Level Hysteresis.....	79
Lower Level Hysteresis.....	80
AF Auto Scale.....	80

Adjusting all Determinable Settings Automatically (Auto All)

Activates all automatic adjustment functions for the current measurement settings, including:

- [Auto Frequency](#)
- [Auto Level](#)
- ["AF Auto Scale"](#) on page 73

Remote command:

[SENSe:]ADJust:ALL on page 125

Adjusting the Center Frequency Automatically (Auto Frequency)

The R&S ESW adjusts the center frequency automatically.

The optimum center frequency is the frequency with the highest S/N ratio in the frequency span. As this function uses the signal counter, it is intended for use with sinusoidal signals.

Remote command:

[\[SENSe:\]ADJust:FREQuency](#) on page 127

Setting the Reference Level Automatically (Auto Level)

Automatically determines a reference level which ensures that no overload occurs at the R&S ESW for the current input data. At the same time, the internal attenuators are adjusted. As a result, the signal-to-noise ratio is optimized, while signal compression and clipping are minimized.

To determine the required reference level, a level measurement is performed on the R&S ESW.

If necessary, you can optimize the reference level further. Decrease the attenuation level manually to the lowest possible value before an overload occurs, then decrease the reference level in the same way.

You can change the measurement time for the level measurement if necessary (see "[\(Meas Time Manual\)](#)" on page 79).

Remote command:

[\[SENSe:\]ADJust:LEVel](#) on page 116

Resetting the Automatic Measurement Time (Meas Time Auto)

Resets the measurement duration for automatic settings to the default value.

Remote command:

[\[SENSe:\]ADJust:CONFigure:LEVel:DURation:MODE](#) on page 125

(Meas Time Manual)

This function allows you to change the measurement duration for automatic setting adjustments. Enter the value in seconds.

Note: The maximum measurement duration depends on the currently selected measurement and the installed (optional) hardware. Thus, the measurement duration actually used to determine the automatic settings can be shorter than the value you define here.

Remote command:

[\[SENSe:\]ADJust:CONFigure:LEVel:DURation:MODE](#) on page 125

[\[SENSe:\]ADJust:CONFigure:LEVel:DURation](#) on page 125

Upper Level Hysteresis

When the reference level is adjusted automatically using the [Auto Level](#) function, the internal attenuators and the preamplifier are also adjusted. To avoid frequent adaptation due to small changes in the input signal, you can define a hysteresis. This setting defines an upper threshold that the signal must exceed (compared to the last measurement) before the reference level is adapted automatically.

Remote command:

[\[SENSe:\]ADJust:CONFigure:HYSTeresis:UPPer](#) on page 126

Lower Level Hysteresis

When the reference level is adjusted automatically using the [Auto Level](#) function, the internal attenuators and the preamplifier are also adjusted. To avoid frequent adaptation due to small changes in the input signal, you can define a hysteresis. This setting defines a lower threshold that the signal must fall below (compared to the last measurement) before the reference level is adapted automatically.

Remote command:

[\[SENSe:\]ADJust:CONFigure:HYSTeresis:LOWer](#) on page 126

AF Auto Scale

Activates automatic scaling of the y-axis for AF measurements. RF power and RF spectrum measurements are not affected by the auto-scaling.

Remote command:

[\[SENSe:\]ADJust:SCALE\[:Y\]:AUTO\[:CONTinuous\]](#) on page 127

6 Analysis

Access

- "Overview" > "Analysis"

General result analysis settings concerning the trace, markers, lines etc. are similar to the analysis functions in the Spectrum application, except for the features described here.

For more information, refer to the R&S ESW User Manual.

- [Trace configuration](#)..... 81
- [Marker settings](#).....82
- [Display lines and limit lines](#)..... 83

6.1 Trace configuration

Access

- "Overview" > "Analysis" > "Trace"

For more information, refer to the user manual of the R&S ESW.

Spectrograms in the Analog Modulation Analysis application

Basically, spectrograms work the same as in the Receiver application.

However, in the Analog Demodulator, they have the following distinctive features.

- Not all result displays support spectrograms.
- Compared to the Receiver or Spectrum application, a spectrogram can not be added as an independent result display. Instead, spectrograms relate to a certain measurement window (or result display). Result diagram and spectrogram are a single entity in that case and can not be divided.

To view results in a spectrogram, select a window (indicated by a blue frame), then select [TRACE] > "Spectrogram Config".

Spectrograms are either displayed in "Split" mode (spectrogram is displayed below the trace diagram), in "Full" mode (trace diagram is not displayed), or not displayed at all ("Off").

When the "Spectrogram Config" softkey is greyed out, spectrograms are not supported by the selected result display.

[State](#).....81

State

Activates and deactivates a Spectrogram subwindow.

"Split" Displays the Spectrogram as a subwindow in the original result display.

"Full" Displays the Spectrogram in a subwindow in the full size of the original result display.

"Off" Closes the Spectrogram subwindow.

Remote command:

[CALCulate<n>:SPECTrogram:LAYout](#) on page 175

6.2 Marker settings

Access

- "Overview" > "Analysis" > "Marker"
- "Overview" > "Analysis" > "Marker Function"

For more information, refer to the user manual of the R&S ESW.

Link AF Spectrum Marker	82
Link Time Marker	82
AF Phase Marker	82

Link AF Spectrum Marker

Links the markers in all AF spectrum displays.

Remote command:

[CALCulate<n>:MARKer<m>:LINK](#) on page 174

Link Time Marker

Links the markers in all time domain diagrams.

Remote command:

[CALCulate<n>:MARKer<m>:LINK](#) on page 174

AF Phase Marker

Access: "Overview" > "Analysis" > "Marker Functions" > "AF Phase"

or: [MKR FUNC] > "Select Marker Function" > "AF Phase"

This marker function is only available for AF spectrum result displays. If enabled, the phase value at each marker position is included in the marker table. The function is always enabled for all active markers in the selected display, it cannot be disabled for individual markers. Note that the phase value is always wrapped, and always absolute, also for delta markers. The unit depends on the phase unit setting (see "[Phase Unit \(Rad/Deg\)](#)" on page 75).

4 Marker Table							
Wnd	Type	Ref	Trc	X-Value	Y-Value	Function	Function Result
1	M1		1	96.2 kHz	30.00 %	Phase-Value	660.99 mrad
1	D1	M1	1	354.67 kHz	-54.93 dB	Phase-Value	1.87 rad
2	M1		1	96.2 kHz	440.08 µrad	Phase-Value	2.83 rad
2	D1	M1	1	354.7 kHz	-8.22 dB	Phase-Value	-2.91 rad

Remote command:

[CALCulate<n>:MARKer<m>:FUNCTION:AFPHase\[:STATE\]](#) on page 175

[CALCulate<n>:MARKer<m>:FUNCTION:AFPHase:RESult?](#) on page 175

[CALCulate<n>:DELTaMarker<m>:FUNCTION:AFPHase\[:STATe\]](#) on page 175

[CALCulate<n>:DELTaMarker<m>:FUNCTION:AFPHase:RESult?](#) on page 175

6.3 Display lines and limit lines

Access (limit lines): "Overview" > "Analysis" > "Lines" > "Limit Lines"

Access (display lines): "Overview" > "Analysis" > "Lines" > "Display Lines"

For more information, refer to the user manual of the R&S ESW.

7 How to perform measurements in the Analog Modulation Analysis application

1. Press [MODE].
2. Select the "AM/FM/PM Modulation Analysis" application.
3. Select "Overview" to display the "Overview" for AM/FM/PM Modulation Analysis.
4. Select "Input/Frontend" > "Frequency" tab to define the input signal's center frequency.
5. Select "Data Acquisition" and define the bandwidth parameters for the input signal:
 - "Demodulation Bandwidth": the span of the input signal to demodulate
 - "Measurement Time": how long the input signal is measured
 - "Resolution Bandwidth": how precise the signal is demodulated
 - "Capture Offset" (multistandard mode only): the offset of the analysis interval from the start of the capture buffer
6. Optionally, select "Trigger" and define a trigger for data acquisition, for example an offline demodulation trigger to start capturing data only when a useful signal is transmitted.
7. Select "Demod/Display" and select the demodulation displays that are of interest to you (up to 6).
Arrange them on the display to suit your preferences.
8. Exit the SmartGrid mode and select "Overview" to display the "Overview" again.
9. Select "Demodulation Settings" to define demodulation parameters for each evaluation:
 - Configure the "Squelch" function (on the "Demod" tab) to suppress noise during demodulation.
 - For time domain evaluations, zoom into the areas of interest by defining a zoom area (on the "Demod" tab).
 - For AF evaluations, use special filters to eliminate certain effects of demodulation or to correct pre-emphasized modulated signals (on the "AF Filters" tab).
 - Adapt the diagram scaling to the displayed data (on the "Scaling" tab).
10. Select "Overview" > "Analysis" to use the advanced analysis functions in the demodulation displays.
 - Configure a trace to display the average over a series of sweeps (on the "Trace" tab. If necessary, increase the "Sweep Count" in the "Data Acquisition" settings).
 - Configure markers and delta markers to determine deviations and offsets within the demodulated signal (on the "Marker" tab).
 - Use special marker functions to calculate phase noise or an n-dB-down bandwidth (on the "Marker Config" tab).

- Configure a limit check to detect excessive deviations (on the "Lines" tab).
11. Start a new sweep with the defined settings.
In multistandard mode, to stop the continuous measurement mode by the Sequencer and perform a single data acquisition:
 - a) Select the Sequencer () from the toolbar.
 - b) Set the Sequencer state to "Off".
 - c) Press [RUN SINGLE].
 12. Optionally, export the trace data of the demodulated signal to a file.
 - a) In the "Traces" tab of the "Analysis" dialog box, switch to the "Trace Export" tab.
 - b) Select "Export Trace to ASCII File".
 - c) Define a file name and storage location and select "OK".

7.1 How to export trace data and numerical results

The measured trace data and numerical measurement results in tables can be exported to an ASCII file. For each measurement point, the measured trace position and value are output.

The file is stored with a `.DAT` or `.CSV` extension. For details on the storage format, see [Section A.3, "Reference: ASCII file export format"](#), on page 183.

To export trace data and table results

1. Select [TRACE] > "Trace Config" > "Trace / Data Export" tab.
2. Select "Export all Traces and all Table Results" to export all available measurement result data for the current application, or select a specific "Trace to Export".
3. Optionally, select "Include Instrument & Measurement Settings" to insert additional information in the export file header.
4. If necessary, change the decimal separator for the ASCII export file.
5. Select "Export Trace to ASCII File".
6. In the file selection dialog box, select the storage location and file name for the export file.
7. Select "Save" to close the dialog box and export the data to the file.

8 Measurement example: demodulating an FM signal

A practical example for a basic Analog Modulation Analysis measurement is provided here. It demonstrates how operating and measurement errors can be avoided using correct configuration settings.

The measurement is performed using the following devices:

- A vector signal generator, e.g. R&S SMW



Figure 8-1: Test setup

Signal generator settings (e.g. R&S SMW):

Frequency:	500 MHz
Level:	-10 dBm
Modulation:	FM
Modulation frequency:	10 kHz
Frequency deviation:	50 kHz

Procedure:

1. Preset the R&S ESW.
2. Set the center frequency to *500 MHz*.
3. Set the reference level to *0 dBm*.
4. Select [MODE] and then "AM FM PM Analog Demod".

By default, the "FM Time Domain" result display and a "Result Summary" are shown.

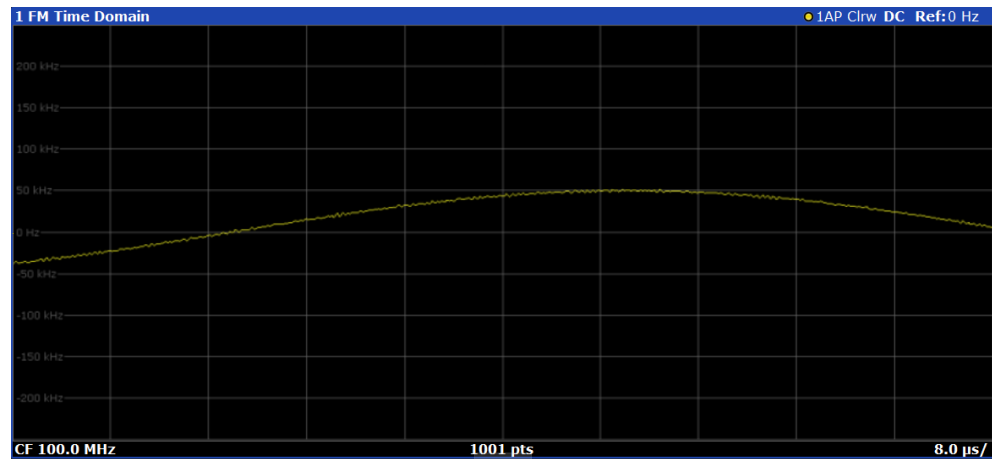

Figure 8-2: Default Analog Modulation Analysis measurement result display

5. Set the measurement time (AQT) to 1 ms to measure 10 periods of the signal.
6. Adjust the y-axis scaling to the measured frequency deviation automatically by selecting "Scale Config" > "Scaling" tab > "AF Auto Scale": "On".

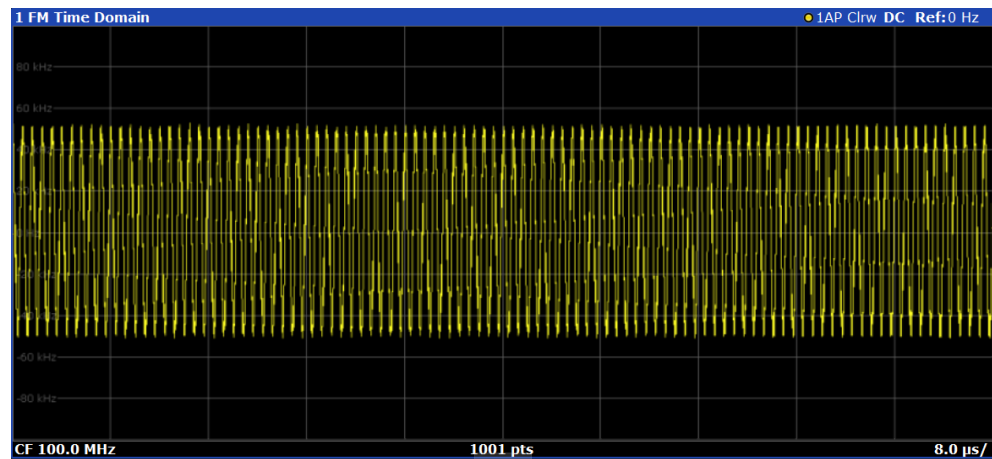

Figure 8-3: Auto-scaled measurement of 10 signal periods (continuous)

7. Display the RF spectrum of the measured signal to determine the required demodulation bandwidth. Select "Display Config" and add an "RF Spectrum" window to the display.

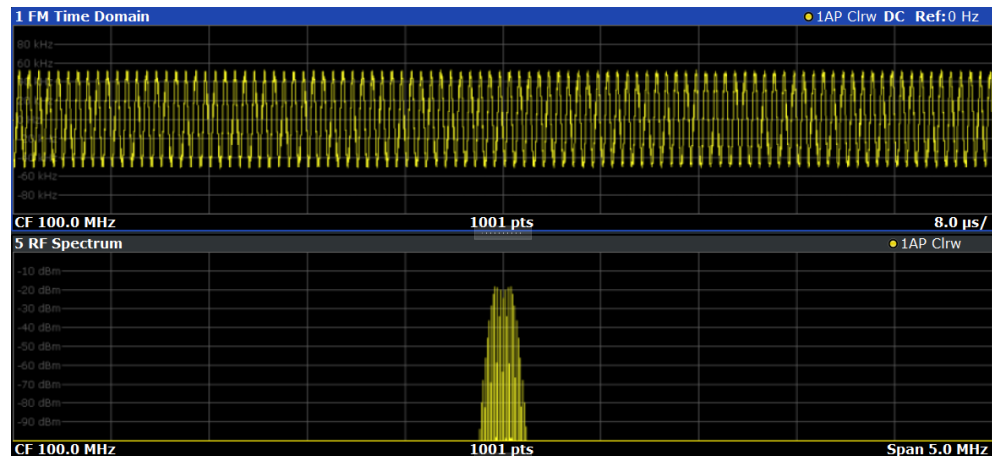

Figure 8-4: RF spectrum of FM signal with default demodulation bandwidth = 5 MHz

8. As you can see in Figure 8-4, the default demodulation bandwidth of 5 MHz is much too large - the actual signal takes up only a small part of the displayed range. That means that any noise or additional signals apart from the FM signal of interest may be included in the measured results. Select "Demod BW" and reduce the value to 200 kHz.

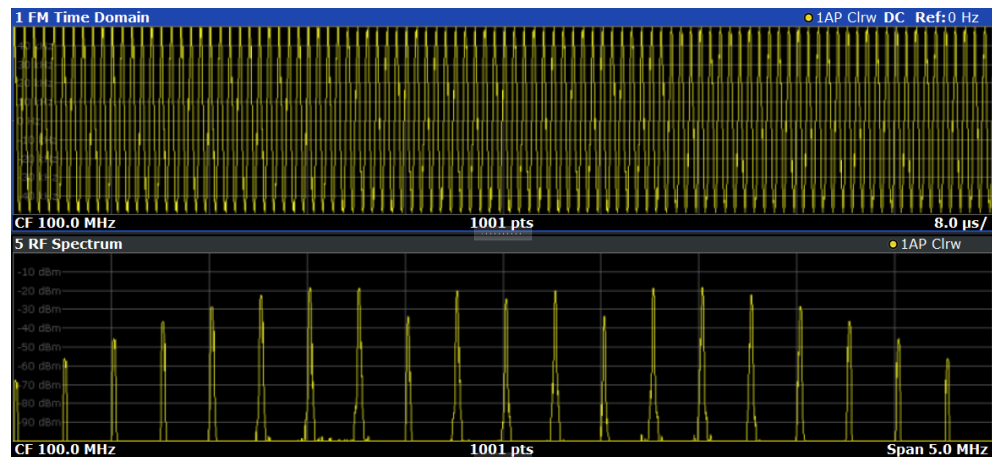

Figure 8-5: RF spectrum with demodulation bandwidth = 200 kHz

The span is automatically reduced to 200 kHz as well, as only the demodulated range can be displayed.

9. Now the RF spectrum shows that part of the FM signal is cut off. The missing signal parts are not included in the calculated results. Increase the demodulation bandwidth to 400 kHz to include the entire signal, but no interfering frequencies. The span is not automatically increased for the wider DBW since it may be useful to display only a small range from the demodulated bandwidth. However, this means the RF spectrum will still not show the entire signal.
10. Increase the span manually to show the entire demodulated bandwidth:
- Select the "RF Spectrum" window.

- b) Press [SPAN].
- c) Select "Full Span".

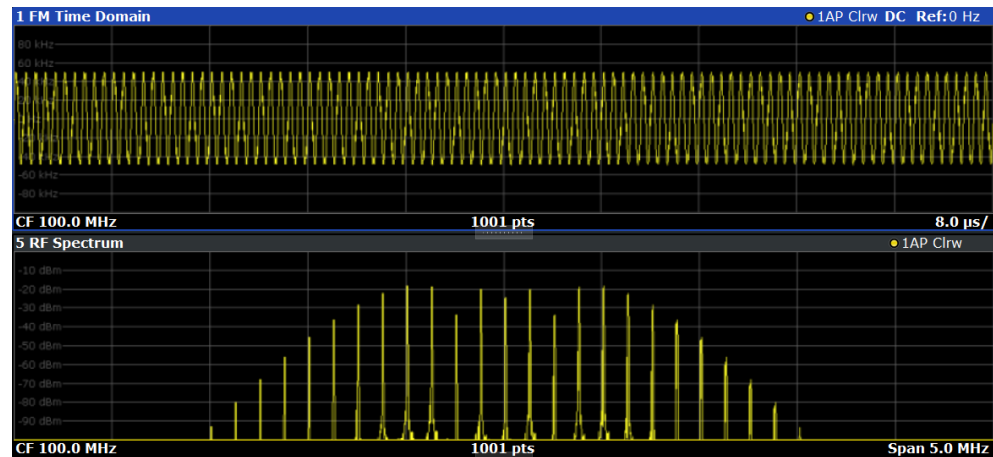

Figure 8-6: RF spectrum with demodulation bandwidth = 400 kHz

11. Once the correct DBW has been determined, you can replace the RF spectrum by the FM spectrum result display to analyze the spectrum of the FM signal. Select "Display Config" and move an "FM Spectrum" window over the "RF Spectrum" window in the display.

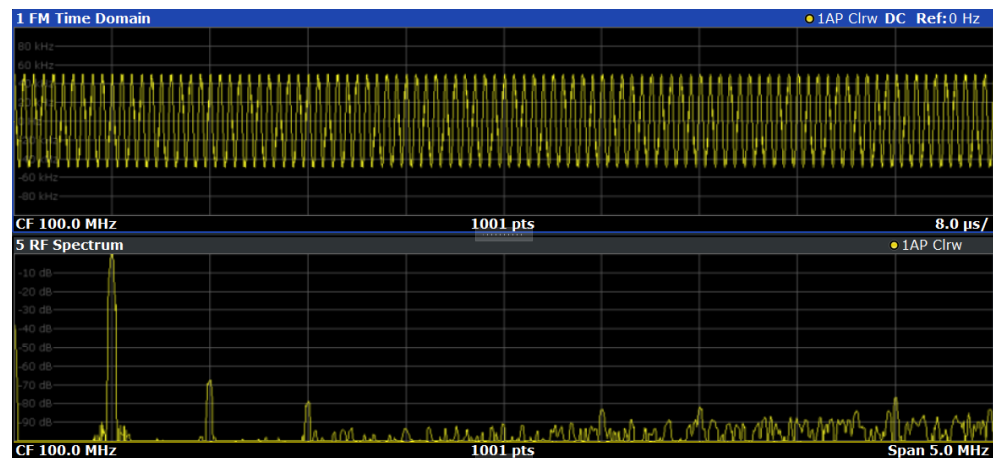
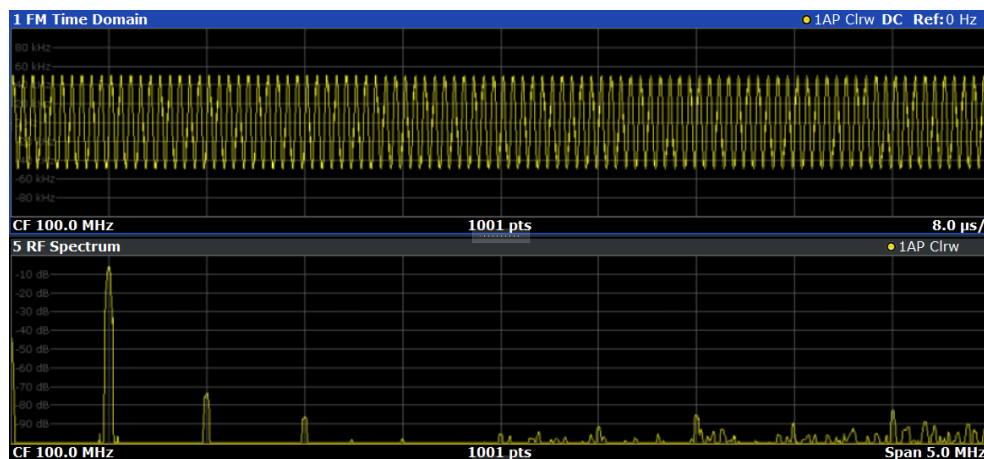

Figure 8-7: FM spectrum and Result Summary including SINAD and THD values

From the FM spectrum, the SINAD and THD are also calculated and displayed in the "Result Summary".

12. Since the "AF Auto Scale" function is enabled, the "FM Spectrum" diagram is scaled according to the current measurement automatically. Each diagram is scaled individually, so that the reference values at the top of the two diagrams can differ (100 kHz in the "FM Time Domain" versus 50 kHz in the "FM Spectrum". However, you can adjust the values manually.
 - a) Select the "FM Spectrum" window to set the focus in it.
 - b) Press [AMPT].

- c) Select "Scale Config".
- d) Disable the "AF Auto Scale" function.
- e) Define the new reference value (at 100% = top of the diagram) as *100 kHz*.



Note that while the reference values at the top of both y-axes are now identical, the reference values indicated in the window title bars are not. This is due to the fact that, by default, in AF time domain displays the reference value is defined at the reference position 50 % (=center of diagram), while in AF frequency domains it is defined at the position 100 % (= top of diagram).

9 Optimizing and troubleshooting the measurement

If the results do not meet your expectations, consider the following notes and tips to optimize the measurement.

Determining the demodulation bandwidth

A frequent cause for measurement errors and false results is an **incorrectly defined demodulation bandwidth (DBW)**.

If the DBW is too large, the actual signal takes up only a small part of the demodulated range. That means that any noise or additional signal parts can be included in the measured results, which are then false.

On the other hand, if the DBW is too small, part of the signal is cut off and thus not included in the calculation of the results.

An easy way to determine the required DBW is to display the RF spectrum of the input signal. If the entire signal is displayed there and takes up most of the diagram width, the DBW is probably appropriate.

For further recommendations on finding the correct demodulation bandwidth, see [Section 4.2, "Demodulation bandwidth"](#), on page 26.

Adjusting the displayed span

Be aware that the span of the "RF Spectrum" display is not automatically increased for a wider DBW. Sometimes, it can be useful to display only a small range from the demodulated bandwidth. Thus, if the RF spectrum does not show the entire demodulated bandwidth, you must increase the span manually to show the entire signal.

Determining the SINAD and THD

The signal-to-noise-and-distortion ratio (SINAD) and the total harmonic distortion (THD) of the demodulated signal are a good indicator of the signal quality sent by the DUT. Both values are calculated inside the AF spectrum span and thus only if an AF spectrum window is displayed. If either value deviates strongly from the expected result, make sure that the demodulation bandwidth is defined correctly (see [Determining the demodulation bandwidth](#)).

10 Remote commands for Analog Modulation Analysis

The following commands are specific to performing measurements in the Analog Modulation Analysis application in a remote environment. The R&S ESW must already be set up for remote operation in a network as described in the base unit manual.

• Introduction	92
• Common suffixes	97
• Application selection	97
• Measurement configuration	101
• Result display configuration	155
• Measurement results	163
• Analysis	174
• Data import and export	176
• Programming example	177

10.1 Introduction

Commands are program messages that a controller (e.g. a PC) sends to the instrument or software. They operate its functions ('setting commands' or 'events') and request information ('query commands'). Some commands can only be used in one way, others work in two ways (setting and query). If not indicated otherwise, the commands can be used for settings and queries.

The syntax of a SCPI command consists of a header and, usually, one or more parameters. To use a command as a query, you have to append a question mark after the last header element, even if the command contains a parameter.

A header contains one or more keywords, separated by a colon. Header and parameters are separated by a "white space" (ASCII code 0 to 9, 11 to 32 decimal, e.g. blank). If there is more than one parameter for a command, they are separated by a comma from one another.

Only the most important characteristics that you need to know when working with SCPI commands are described here. For a more complete description, refer to the user manual of the R&S ESW.



Remote command examples

Note that some remote command examples mentioned in this general introduction are possibly not supported by this particular application.

10.1.1 Conventions used in descriptions

The following conventions are used in the remote command descriptions:

- *Command usage*

If not specified otherwise, commands can be used both for setting and for querying parameters.

If a command can be used for setting or querying only, or if it initiates an event, the usage is stated explicitly.

- *Parameter usage*

If not specified otherwise, a parameter can be used to set a value, and it is the result of a query.

Parameters required only for setting are indicated as "Setting parameters".

Parameters required only to refine a query are indicated as "Query parameters".

Parameters that are only returned as the result of a query are indicated as "Return values".

- *Conformity*

Commands that are taken from the SCPI standard are indicated as "SCPI confirmed". All commands used by the R&S ESW follow the SCPI syntax rules.

- *Asynchronous commands*

A command which does not automatically finish executing before the next command starts executing (overlapping command) is indicated as an "Asynchronous command".

- *Reset values (*RST)*

Default parameter values that are used directly after resetting the instrument (*RST command) are indicated as "*RST" values, if available.

- *Default unit*

The default unit is used for numeric values if no other unit is provided with the parameter.

- *Manual operation*

If the result of a remote command can also be achieved in manual operation, a link to the description is inserted.

10.1.2 Long and short form

The keywords have a long and a short form. You can use either the long or the short form, but no other abbreviations of the keywords.

The short form is emphasized in uppercase letters. Note however, that this emphasis only serves the purpose to distinguish the short from the long form in the manual. For the instrument, the case does not matter.

Example:

SENSe:FREQuency:CENTer is the same as SENS:FREQ:CENT.

10.1.3 Numeric suffixes

Some keywords have a numeric suffix if the command can be applied to multiple instances of an object. In that case, the suffix selects a particular instance (e.g. a measurement window).

Numeric suffixes are indicated by angular brackets (<n>) next to the keyword.

If you do not quote a suffix for keywords that support one, a 1 is assumed.

Example:

`DISPlay[:WINDow<1...4>]:ZOOM:STATe` enables the zoom in a particular measurement window, selected by the suffix at `WINDow`.

`DISPlay:WINDow4:ZOOM:STATe ON` refers to window 4.

10.1.4 Optional keywords

Some keywords are optional and are only part of the syntax because of SCPI compliance. You can include them in the header or not.



If an optional keyword has a numeric suffix and you need to use the suffix, you have to include the optional keyword. Otherwise, the suffix of the missing keyword is assumed to be the value 1.

Optional keywords are emphasized with square brackets.

Example:

Without a numeric suffix in the optional keyword:

`[SENSe:]FREQuency:CENTer` is the same as `FREQuency:CENTer`

With a numeric suffix in the optional keyword:

`DISPlay[:WINDow<1...4>]:ZOOM:STATe`

`DISPlay:ZOOM:STATe ON` enables the zoom in window 1 (no suffix).

`DISPlay:WINDow4:ZOOM:STATe ON` enables the zoom in window 4.

10.1.5 Alternative keywords

A vertical stroke indicates alternatives for a specific keyword. You can use both keywords to the same effect.

Example:

`[SENSe:]BANDwidth|BWIDth[:RESolution]`

In the short form without optional keywords, `BAND 1MHZ` would have the same effect as `BWID 1MHZ`.

10.1.6 SCPI parameters

Many commands feature one or more parameters.

If a command supports more than one parameter, they are separated by a comma.

Example:

```
LAYout:ADD:WINDow Spectrum,LEFT,MTABLE
```

Parameters can have different forms of values.

- [Numeric values](#)..... 95
- [Boolean](#)..... 96
- [Character data](#)..... 96
- [Character strings](#)..... 96
- [Block data](#)..... 96

10.1.6.1 Numeric values

Numeric values can be entered in any form, i.e. with sign, decimal point or exponent. For physical quantities, you can also add the unit. If the unit is missing, the command uses the basic unit.

Example:

With unit: `SENSe:FREQuency:CENTer 1GHZ`

Without unit: `SENSe:FREQuency:CENTer 1E9` would also set a frequency of 1 GHz.

Values exceeding the resolution of the instrument are rounded up or down.

If the number you have entered is not supported (e.g. for discrete steps), the command returns an error.

Instead of a number, you can also set numeric values with a text parameter in special cases.

- **MIN/MAX**
Defines the minimum or maximum numeric value that is supported.
- **DEF**
Defines the default value.
- **UP/DOWN**
Increases or decreases the numeric value by one step. The step size depends on the setting. Sometimes, you can customize the step size with a corresponding command.

Querying numeric values

When you query numeric values, the system returns a number. For physical quantities, it applies the basic unit (e.g. Hz for frequencies). The number of digits after the decimal point depends on the type of numeric value.

Example:

Setting: `SENSe:FREQuency:CENTer 1GHZ`

Query: `SENSe:FREQuency:CENTer?` would return `1E9`

Sometimes, numeric values are returned as text.

- INF/NINF
Infinity or negative infinity. Represents the numeric values 9.9E37 or -9.9E37.
- NAN
Not a number. Represents the numeric value 9.91E37. NAN is returned if errors occur.

10.1.6.2 Boolean

Boolean parameters represent two states. The "on" state (logically true) is represented by "ON" or the numeric value 1. The "off" state (logically untrue) is represented by "OFF" or the numeric value 0.

Querying Boolean parameters

When you query Boolean parameters, the system returns either the value 1 ("ON") or the value 0 ("OFF").

Example:

Setting: `DISPlay:WINDow:ZOOM:STATe ON`

Query: `DISPlay:WINDow:ZOOM:STATe?` would return 1

10.1.6.3 Character data

Character data follows the syntactic rules of keywords. You can enter text using a short or a long form. For more information, see [Section 10.1.2, "Long and short form"](#), on page 93.

Querying text parameters

When you query text parameters, the system returns its short form.

Example:

Setting: `SENSe:BANDwidth:RESolution:TYPE NORMAL`

Query: `SENSe:BANDwidth:RESolution:TYPE?` would return NORM

10.1.6.4 Character strings

Strings are alphanumeric characters. They have to be in straight quotation marks. You can use a single quotation mark (') or a double quotation mark (").

Example:

`INSTRument:DELeTe 'Spectrum'`

10.1.6.5 Block data

Block data is a format which is suitable for the transmission of large amounts of data.

The ASCII character # introduces the data block. The next number indicates how many of the following digits describe the length of the data block. The data bytes follow. During the transmission of these data bytes, all end or other control signs are ignored until all bytes are transmitted. #0 specifies a data block of indefinite length. The use of the indefinite format requires an NL^END message to terminate the data block. This format is useful when the length of the transmission is not known or if speed or other considerations prevent segmentation of the data into blocks of definite length.

10.2 Common suffixes

In the Analog Modulation Analysis application, the following common suffixes are used in remote commands:

Table 10-1: Common suffixes used in remote commands in the Analog Modulation Analysis application

Suffix	Value range	Description
<m>	1..16	Marker
<n>	1..16	Window (in the currently selected channel)
<t>	1..6	Trace
	1 to 8	Limit line
<i>	1..3	Selects one of the analog output channels (1, 2 or Phones).
<k>	1..8 (Limit line) 1 2 (Display line)	Selects a limit or display line.
<peak>	1..3000	Selects a peak.
<sr>	1..10	Selects a scan range.



Selecting windows in multiple channels

Note that the suffix <n> always refers to a window in the currently selected channel.

10.3 Application selection

INSTRument:CREate:DUPLicate.....	98
INSTRument:CREate[:NEW].....	98
INSTRument:CREate:REPLace.....	98
INSTRument:DELeTe.....	99
INSTRument:LIST?.....	99
INSTRument:REName.....	100
INSTRument[:SELeCt].....	100
SYSTem:PRESet:CHANnel[:EXEC].....	101

INSTrument:CREate:DUPLicate

Duplicates the currently selected channel, i.e creates a new channel of the same type and with the identical measurement settings. The name of the new channel is the same as the copied channel, extended by a consecutive number (e.g. "IQAnalyzer" -> "IQAnalyzer 2").

The channel to be duplicated must be selected first using the `INST:SEL` command.

Example:

```
INST:SEL 'Receiver'
INST:CRE:DUPL
```

Duplicates the channel named 'Receiver' and creates a new channel named 'Receiver 2'.

Usage: Event

INSTrument:CREate[:NEW] <ChannelType>, <ChannelName>

Adds a measurement channel. You can configure up to 10 measurement channels at the same time (depending on available memory).

Parameters:

<ChannelType> Channel type of the new channel.
For a list of available channel types, see [INSTrument:LIST?](#) on page 99.

<ChannelName> String containing the name of the channel.
Note that you cannot assign an existing channel name to a new channel. If you do, an error occurs.

Example:

```
INST:CRE SAN, 'Spectrum 2'
```

Adds a spectrum display named "Spectrum 2".

INSTrument:CREate:REPLace <ChannelName1>, <ChannelType>, <ChannelName2>

Replaces a channel with another one.

Setting parameters:

<ChannelName1> String containing the name of the channel you want to replace.

<ChannelType> Channel type of the new channel.
For a list of available channel types, see [INSTrument:LIST?](#) on page 99.

<ChannelName2> String containing the name of the new channel.
Note: If the specified name for a new channel already exists, the default name, extended by a sequential number, is used for the new channel (see [INSTrument:LIST?](#) on page 99).
Channel names can have a maximum of 31 characters, and must be compatible with the Windows conventions for file names. In particular, they must not contain special characters such as ":", "*", "?".

Example: `INST:CRE:REPL 'Receiver',REC,'REC2'`
Replaces the channel named "Receiver" by a new channel of type "Receiver" named "REC2".

Usage: Setting only

INSTrument:DELeTe <ChannelName>

Deletes a channel.

If you delete the last channel, the default "Receiver" channel is activated.

Setting parameters:

<ChannelName> String containing the name of the channel you want to delete. A channel must exist to delete it.

Example: `INST:DEL 'Receiver'`
Deletes the channel with the name 'Receiver'.

Usage: Setting only

INSTrument:LIST?

Queries all active channels. The query is useful to obtain the names of the existing channels, which are required to replace or delete the channels.

Return values:

<ChannelType>, <ChannelName> For each channel, the command returns the channel type and channel name (see tables below).
Tip: to change the channel name, use the [INSTrument:REName](#) command.

Example: `INST:LIST?`
Result for 2 channels:
'REC', 'Receiver', 'REC', 'Receiver 2'

Usage: Query only

Table 10-2: Available channel types and default channel names

Application	<ChannelType> Parameter	Default Channel Name*)
Analog Modulation Analysis	ADEMod	Analog Demod
CISPR APD	n/a	CISPR APD
Click Rate Analyzer	CRAnalyzer	Click Rate Analyzer
I/Q Analyzer	IQ	IQ Analyzer
Multi CISPR APD	MAPD	Multi CISPR APD
Real-Time Spectrogram	RTSG	Real-Time Spectrogram
Real-Time Spectrum	RTIM	Real-Time Spectrum

Note: the default channel name is also listed in the table. If the specified name for a new channel already exists, the default name, extended by a sequential number, is used for the new channel.

Application	<ChannelType> Parameter	Default Channel Name*)
Receiver	RECeiver	Receiver
Spectrum	SANalyzer	Spectrum

Note: the default channel name is also listed in the table. If the specified name for a new channel already exists, the default name, extended by a sequential number, is used for the new channel.

INSTrument:REName <ChannelName1>, <ChannelName2>

Renames a channel.

Setting parameters:

<ChannelName1> String containing the name of the channel you want to rename.

<ChannelName2> String containing the new channel name.
 Note that you cannot assign an existing channel name to a new channel. If you do, an error occurs.
 Channel names can have a maximum of 31 characters, and must be compatible with the Windows conventions for file names. In particular, they must not contain special characters such as ":", "*", "?".

Example: `INST:REN 'Receiver', 'REC'`
 Renames the channel with the name 'Receiver' to 'REC'.

Usage: Setting only

INSTrument[:SElect] <ChannelType> | <ChannelName>

Activates a new channel with the defined channel type, or selects an existing channel with the specified name.

Also see

- [INSTrument:CREate\[:NEW\]](#) on page 98

Parameters:

<ChannelType> Channel type of the new channel.
 For a list of available channel types see [INSTrument:LIST?](#) on page 99.

<ChannelName> String containing the name of the channel.

Example: `INST IQ`
 Activates a channel for the I/Q Analyzer application (evaluation mode).
`INST 'MyIQSpectrum'`
 Selects the channel named 'MyIQSpectrum' (for example before executing further commands for that channel).

SYSTem:PRESet:CHANnel[:EXEC]

Restores the default <instrument> settings in the current channel.

Use `INST:SEL` to select the channel.

Example:

```
INST:SEL 'Spectrum2'
```

Selects the channel for "Spectrum2".

```
SYST:PRESet:CHAN:EXEC
```

Restores the factory default settings to the "Spectrum2" channel.

Usage:

Event

Manual operation: See "[Preset Channel](#)" on page 38

10.4 Measurement configuration

- [Standard selection](#)..... 101
- [Input configuration](#)..... 102
- [Output configuration](#)..... 104
- [Amplitude configuration](#)..... 113
- [Frequency configuration](#)..... 116
- [Trigger configuration](#)..... 118
- [Automatic configuration](#)..... 124
- [Data acquisition](#)..... 128
- [Demodulation settings](#)..... 136

10.4.1 Standard selection

- [\[SENSe:\]ADEMod:PRESet\[:STANdard\]](#)..... 101
- [\[SENSe:\]ADEMod:PRESet:RESTore](#)..... 102
- [\[SENSe:\]ADEMod:PRESet:STORe](#)..... 102

[SENSe:]ADEMod:PRESet[:STANdard] <Standard>

Loads a measurement configuration.

Standard definitions are stored in an xml file. The default directory for Analog Modulation Analysis standards is C:

```
\R_S\Instr\User\predefined\AdemodPredefined.
```

Parameters:

<Standard>

String containing the file name.

If you have stored the file in a subdirectory of the directory mentioned above, you have to include the relative path to the file.

Manual operation: See "[Load Standard](#)" on page 37

[SENSe:]ADEMod:PRESet:RESTore

Manual operation: See ["Restore Standard Files"](#) on page 38

[SENSe:]ADEMod:PRESet:STORE <Standard>

Saves the current Analog Modulation Analysis measurement configuration.

Standard definitions are stored in an XML file. The default directory for Analog Modulation Analysis standards is C :

\R_S\Instr\User\predefined\AdemodPredefined.

Parameters:

<Standard> String containing the file name.
You can save the file in a subdirectory of the directory mentioned above. In that case, you have to include the relative path to the file.

Manual operation: See ["Save Standard"](#) on page 37

10.4.2 Input configuration

- [RF input](#).....102
- [External mixer \(Optional\)](#)..... 104
- [Preselector configuration](#)..... 104
- [External generator configuration \(Optional\)](#)..... 104
- [LISN configuration](#).....104

10.4.2.1 RF input

INPut:ATTenuation:LIMiter[:STATe]	102
INPut:ATTenuation:PROTection:RESet	103
INPut:COUPling	103
INPut:IMPedance	103
INPut:TYPE	103

INPut:ATTenuation:LIMiter[:STATe] <State>

This command turns the pulse limiter on and off.

The pulse limiter is an additional protection mechanism for the second RF input that attenuates high level pulses.

Parameters:

<State> ON | OFF | 1 | 0
*RST: ON

Example: //Turn on pulse limiter
INP:ATT:LIM ON

Manual operation: See ["Pulse Limiter"](#) on page 41

INPut:ATTenuation:PROTection:RESet

Resets the attenuator and reconnects the RF input with the input mixer for the R&S ESW after an overload condition occurred and the protection mechanism intervened. The error status bit (bit 3 in the `STAT:QUES:POW` status register) and the `INPUT OVLD` message in the status bar are cleared.

(For details on the status register see the R&S ESW base unit user manual).

The command works only if the overload condition has been eliminated first.

Example: `INP:ATT:PROT:RES`

INPut:COUPling <CouplingType>

Selects the coupling type of the RF input.

Parameters:

<CouplingType> AC | DC
AC
 AC coupling
DC
 DC coupling
 *RST: AC

Example: `INP:COUP DC`

Manual operation: See "[Input Coupling](#)" on page 40

INPut:IMPedance <Impedance>

Selects the nominal input impedance of the RF input. In some applications, only 50 Ω are supported.

Parameters:

<Impedance> 50 | 75
 *RST: 50 Ω
 Default unit: OHM

Example: `INP:IMP 75`

Manual operation: See "[Impedance](#)" on page 41
 See "[Unit](#)" on page 50

INPut:TYPE <Input>

The command selects the input path.

Parameters:

<Input> **INPUT1**
 Selects RF input 1.

INPUT2

Selects RF input 2.

`*RST: INPUT1`

Example: `//Select input path`
`INP:TYPE INPUT1`

Manual operation: See "[Input Selection](#)" on page 40

10.4.2.2 External mixer (Optional)

The remote commands to configure external mixers are the same as in the Spectrum application.

For a comprehensive list of commands, refer to the user manual of the R&S ESW Spectrum application.

10.4.2.3 Preselector configuration

The remote commands to configure the preselector are the same as in the Receiver application.

For a comprehensive list of commands, refer to the user manual of the R&S ESW.

10.4.2.4 External generator configuration (Optional)

The remote commands to configure external generator are the same as in the Receiver application.

For a comprehensive list of commands, refer to the user manual of the R&S ESW.

10.4.2.5 LISN configuration

The remote commands to configure LISNs are the same as in the Receiver application.

For a comprehensive list of commands, refer to the user manual of the R&S ESW.

10.4.3 Output configuration

- [Signal output](#)..... 104
- [Other outputs](#)..... 110

10.4.3.1 Signal output

OUTPut<ou>:IF:AUDio	105
OUTPut<ou>:IF:COUPling	105
OUTPut<ou>:IF:IFFRequency	105
OUTPut<ou>:IF:LPASs:FREQuency:MANual	106
OUTPut<ou>:IF:LPASs[:STATe]	106

OUTPut<ou>:IF:SCALe[:VALue].....	107
OUTPut<ou>:IF[:SOURce].....	107
OUTPut<ou>:LINK.....	108
OUTPut:ADEMod[:ONLine]:SOURce.....	108
[SENSe:]DEMod:SQUelch:LEVel.....	108
[SENSe:]DEMod:SQUelch[:STATe].....	109
SYSTem:SPEaker:MAXVolume.....	109
SYSTem:SPEaker:MUTE.....	110
SYSTem:SPEaker:VOLume.....	110

OUTPut<ou>:IF:AUDio <State>

This command turns additional signal output on the headphone jack on and off.

Available for output 1 and output 2.

Suffix:

<ou> irrelevant

Parameters:

<State> ON | OFF | 1 | 0

Example:

```
//Turn on audio output
OUTP:IF:AUD ON
```

Manual operation: See "[Phones](#)" on page 45

OUTPut<ou>:IF:COUPling <Coupling>

This command selects the output coupling type.

Available for the following output types:

- Video
- FM

Suffix:

<ou> [Output](#)

Parameters:

<Coupling> **AC**
 AC coupling: rejects the DC component of the signal.
DC
 DC coupling: transfers the complete signal.

Example:

```
//Select AC coupling for output 2
OUTP2:IF:COUP AC
```

Manual operation: See "[Coupling](#)" on page 44

OUTPut<ou>:IF:IFFRequency <Frequency>

This command defines the frequency of the IF signal that is output.

Available for output of the IF signal.

Suffix:

<ou> [Output](#)

Parameters:

<Frequency> Default unit: Hz

Example:

```
//Output IF signal with a frequency of 100 MHz
OUTP:IF IF
OUTP:IF:IFFR 100MHZ
```

Manual operation: See "[IF Output Frequency](#)" on page 44

OUTPut<ou>:IF:LPASs:FREQuency:MANual <Frequency>

This command defines the cutoff frequency of the low pass filter available for signal output.

Available for the following output types:

- Video
- AM
- FM
- PM

This command is available after you have turned on the low pass filter with [OUTPut<ou>:IF:LPASs\[:STATe\]](#).

Suffix:

<ou> [Output](#)

Parameters:

<Frequency> Default unit: Hz

Example:

```
//Turn on low pass filter with a cutoff frequency of 100 kHz
OUTP:IF:LPAS ON
OUTP:IF:LPAS:FREQ:MAN 100KHZ
```

Manual operation: See "[Low Pass](#)" on page 45

OUTPut<ou>:IF:LPASs[:STATe] <State>

This command turns a low pass filter to control the output on and off.

Available for the following output types:

- Video
- AM
- FM
- PM

Suffix:

<ou> [Output](#)

Parameters:

<State> ON | OFF | 1 | 0

Example: //Turn on low pass filter with a cutoff frequency of 100 kHz
 OUTP:IF:LPAS ON
 OUTP:IF:LPAS:FREQ:MAN 100KHZ

Manual operation: See "[Low Pass](#)" on page 45

OUTPut<ou>:IF:SCALe[:VALue] <Scale>

This command defines the scale of the transferred signal.

Available for the following output types:

- AM
- FM

Suffix:

<ou> [Output](#)

Parameters:

<Scale> Numeric value whose unit depends on the output type:

- % for AM output
- Hz for FM output

Example: //Select a scale of 100 kHz for FM output on output 1
 OUTP:IF FM
 OUTP:IF:SCAL 100KHZ

Manual operation: See "[Scale](#)" on page 45

OUTPut<ou>:IF[:SOURce] <Type>

This command selects the type of signal data that is output.

Suffix:

<ou> [Output](#)

Parameters:

<Type>

AM
Outputs the AM signal.

FM
Outputs the FM signal.

FOCUS
Outputs the data of the currently selected measurement window.
Available for Analog Modulation Analysis.

IF
Outputs the IF signal.
Unavailable for audio output.

OFF
Turns off the output.

VIDeo
Outputs the video signal.
Unavailable for audio output.

Example: //Select output of AM signal data
 OUTP:IF:SOUR AM

Manual operation: See ["Selecting the output type"](#) on page 43

OUTPut<ou>:LINK <Scope>

This command selects the scope of the output settings.

Suffix:

<ou> irrelevant

Parameters:

<Scope> **ON | 1**
 Output settings apply to the current measurement channel.
OFF | 0
 Output settings apply to all measurement channels.

Example: //Apply output configuration to all measurement channels
 OUTP:LINK OFF

Manual operation: See ["Output Coupling"](#) on page 43

OUTPut:ADEMod[:ONLine]:SOURce <WindowName>

Selects the result display whose results are output. Only active time domain results can be selected.

Parameters:

<WindowName> **<string>**
 String containing the name of the window.
 By default, the name of a window is the same as its index. To determine the name and index of all active windows, use the [LAYout:CATalog\[:WINDow\]?](#) query.

FOCUS

Dynamically switches to the currently selected window. If a window is selected that does not contain a time-domain result display, the selection is ignored and the previous setting is maintained.

Example: OUTP:ADEM:ONL:SOUR 'AnalogDemod'
 OR:
 DISP:WIND1:SEL
 OUTP:ADEM:SOUR FOC

Manual operation: See ["Selecting the window with the output signal"](#) on page 44

[SENSe:]DEMod:SQUelch:LEVel <Level>

This command defines the relative squelch level for audio output, below which the output is not demodulated.

If you are using the "Marker Demodulation" marker function in the spectrum application, the command instead selects the level below which the signal at the marker position is not demodulated.

Parameters:

<Level> <numeric value>
 Default unit: PCT

Example:

```
//Configure squelch for audio output
DEM:SQU ON
DEM:SQU:LEV 10
```

Manual operation: See "[Squelch](#)" on page 45

[SENSe:]DEMod:SQUelch[:STATe] <State>

This command turns a squelch for the audio output on and off.

The squelch is available for the following outputs.

- AM
- FM

If you are using the "Marker Demodulation" marker function in the spectrum application, the command instead turns selective demodulation at the marker position on and off. For selective demodulation, the R&S ESW turns on a video trigger whose level corresponds to the squelch level. Therefore it turns off other triggers or gates.

In both cases, you can define the squelch level with [\[SENSe:\]DEMod:SQUelch:LEVel](#).

Parameters:

<State> ON | OFF | 1 | 0
 *RST: OFF

Example:

```
//Configure squelch for audio output
DEM:SQU ON
DEM:SQU:LEV 10
```

Manual operation: See "[Squelch](#)" on page 45

SYSTem:SPEaker:MAXVolume <Volume>

This command defines the maximum volume level for audio output (for example over headphones).

Parameters:

<Volume> Numeric value between 0 and 1, with 1 being the loudest.

Example:

```
//Define a maximum volume of 60 %
SYST:SPE:MAXV 0.6
```

Manual operation: See "[Controlling the volume](#)" on page 45

SYSTem:SPEaker:MUTE

This command turns off audio output.

To turn the volume back on again, use [SYSTem:SPEaker:VOLume](#).

Example: //Turn off audio output
 SYST:SPE:MUTE
 //Turn audio output back on
 SYST:SPE:VOL 25

Usage: Event

Manual operation: See "[Controlling the volume](#)" on page 45

SYSTem:SPEaker:VOLume <Volume>

This command defines the volume with which audio signals are output.

Parameters:

<Volume> Numeric value between 0 and 1, with 1 being the loudest.
 Note that if you have defined a maximum volume level with
[SYSTem:SPEaker:MAXVolume](#), the value range is limited by
 the maximum volume.

Example: //Define a volume of 25 %.
 SYST:SPE:VOL 0.25

Manual operation: See "[Controlling the volume](#)" on page 45

10.4.3.2 Other outputs

OUTPut<ou>:PROBe<pb>[:POWER]	110
OUTPut:TRIGger<tp>:DIRection	111
OUTPut:TRIGger<tp>:LEVel	111
OUTPut:TRIGger<tp>:OTYPe	111
OUTPut:TRIGger<tp>:PULSe:IMMediate	112
OUTPut:TRIGger<tp>:PULSe:LENGth	112

OUTPut<ou>:PROBe<pb>[:POWER] <State>

This command selects the probe connector that is supplied with power.

Suffix:

<ou> irrelevant
 <pb> Selects the probe power connector.

Parameters:

<State> ON | OFF | 1 | 0

Example: //Supply 5-pin probe connector with power
 OUTP:PROB2 ON

Manual operation: See "[Probe Power Supply](#)" on page 46

OUTPut:TRIGger<tp>:DIRection <Direction>

Selects the trigger direction for trigger ports that serve as an input as well as an output.

Suffix:

<tp> Selects the used trigger port.
 2 = trigger port 2 (front)
 3 = trigger port 3 (rear panel)

Parameters:

<Direction> INPut | OUTPut

INPut
 Port works as an input.

OUTPut
 Port works as an output.

*RST: INPut

Manual operation: See "[Trigger 2/3](#)" on page 47

OUTPut:TRIGger<tp>:LEVel <Level>

Defines the level of the (TTL compatible) signal generated at the trigger output.

Works only if you have selected a user-defined output with [OUTPut:TRIGger<tp>:OTYPe](#).

Suffix:

<tp> 1..n
 Selects the trigger port to which the output is sent.
 2 = trigger port 2 (front)
 3 = trigger port 3 (rear)

Parameters:

<Level> **HIGH**
 5 V

LOW
 0 V

*RST: LOW

Example: OUTP:TRIG2:LEV HIGH

Manual operation: See "[Level](#)" on page 48

OUTPut:TRIGger<tp>:OTYPe <OutputType>

Selects the type of signal generated at the trigger output.

Note: For offline AF or RF triggers, no output signal is provided.

Suffix:

<tp> 1..n
 Selects the trigger port to which the output is sent.
 2 = trigger port 2 (front)
 3 = trigger port 3 (rear)

Parameters:

<OutputType> **DEvice**
 Sends a trigger signal when the R&S ESW has triggered internally.

TARMed
 Sends a trigger signal when the trigger is armed and ready for an external trigger event.

UDEFined
 Sends a user-defined trigger signal. For more information, see [OUTPut:TRIGger<tp>:LEVel](#).

*RST: DEvice

Manual operation: See "[Output Type](#)" on page 47

OUTPut:TRIGger<tp>:PULSe:IMMediate

Generates a pulse at the trigger output.

Suffix:

<tp> 1..n
 Selects the trigger port to which the output is sent.
 2 = trigger port 2 (front)
 3 = trigger port 3 (rear)

Manual operation: See "[Send Trigger](#)" on page 48

OUTPut:TRIGger<tp>:PULSe:LENGth <Length>

Defines the length of the pulse generated at the trigger output.

Suffix:

<tp> Selects the trigger port to which the output is sent.
 2 = trigger port 2 (front)
 3 = trigger port 3 (rear)

Parameters:

<Length> Pulse length in seconds.
 Default unit: S

Example: `OUTP:TRIG2:PULS:LENG 0.02`

Manual operation: See "[Pulse Length](#)" on page 48

10.4.4 Amplitude configuration

Commands to configure the amplitude described elsewhere.

- `INPut:COUPling` on page 103
- `INPut:IMPedance` on page 103

<code>CALCulate<n>:UNIT:POWER</code>	113
<code>DISPlay[:WINDow<n>][:SUBWindow<w>]:TRACe<t>:Y[:SCALE]:RLEVel</code>	113
<code>DISPlay[:WINDow<n>][:SUBWindow<w>]:TRACe<t>:Y[:SCALE]:RLEVel:OFFSet</code>	114
<code>INPut:ATTenuation:AUTO</code>	114
<code>INPut:ATTenuation:PROTection[:STATe]</code>	115
<code>INPut:ATTenuation[:VALue]</code>	115
<code>INPut:GAIN:AUTO</code>	115
<code>INPut:GAIN:LNA:AUTO</code>	115
<code>INPut:GAIN:LNA:STATe</code>	116
<code>INPut:GAIN:STATe</code>	116
<code>[SENSe:]ADJust:LEVel</code>	116

`CALCulate<n>:UNIT:POWER <Unit>`

Selects the power unit.

The unit applies to all power-based measurement windows with absolute values.

In addition, the unit of the reference level is adapted to the same unit.

Suffix:

<n> irrelevant

Parameters:

<Unit> *RST: dBm

Example:

`CALC:UNIT:POW DBM`

Sets the power unit to dBm.

Manual operation: See "[Unit](#)" on page 50

`DISPlay[:WINDow<n>][:SUBWindow<w>]:TRACe<t>:Y[:SCALE]:RLEVel <ReferenceLevel>`

Defines the reference level (for all traces in all windows).

With a reference level offset $\neq 0$, the value range of the reference level is modified by the offset.

Suffix:

<n> irrelevant

<w> subwindow
Not supported by all applications

<t> irrelevant

Parameters:

<ReferenceLevel> The unit is variable.
 Range: see specifications document
 *RST: 0 dBm
 Default unit: DBM

Example: `DISP:TRAC:Y:RLEV -60dBm`

Manual operation: See ["Reference Level"](#) on page 49

DISPlay[:WINDow<n>][:SUBWindow<w>]:TRACe<t>:Y[:SCALE]:RLEVel:OFFSet
 <Offset>

Defines a reference level offset (for all traces in all windows).

Suffix:

<n> irrelevant
 <w> subwindow
 Not supported by all applications
 <t> irrelevant

Parameters:

<Offset> Range: -200 dB to 200 dB
 *RST: 0dB
 Default unit: DB

Example: `DISP:TRAC:Y:RLEV:OFFS -10dB`

Manual operation: See ["Shifting the Display \(Offset\)"](#) on page 50

INPut:ATTenuation:AUTO <State>

This command turns automatic determination of the attenuation level on and off.

When you turn it on, the R&S ESW selects an attenuation that results in a good signal-to-noise ratio without overloading the RF input.

Parameters:

<State> ON | OFF
ON
 Selects automatic attenuation mode.
OFF
 Selects manual attenuation mode.
 *RST: ON

Example: `//Turn on auto ranging`
`INP:ATT:AUTO ON`

Manual operation: See ["Attenuation"](#) on page 51

INPut:ATTenuation:PROTection[:STATe] <State>

This command turns the availability of attenuation levels of 10 dB or less on and off.

Parameters:

<State> ON | OFF | 1 | 0
*RST: 1

Example: //Turn on input protection
 INP:ATT:PROT ON

Manual operation: See "[10 dB Minimum Attenuation](#)" on page 51

INPut:ATTenuation[:VALue] <Attenuation>

This command defines the attenuation at the RF input.

To protect the input mixer, attenuation levels of 10 dB or less are possible only if you have turned off the input protection with [INPut:ATTenuation:PROTection\[:STATe\]](#) on page 115.

Example: //Define attenuation
 INP:ATT 40dB

Manual operation: See "[Attenuation](#)" on page 51

INPut:GAIN:AUTO <State>

This command includes and excludes the preamplifier from the auto ranging feature.

Parameters:

<State> ON | OFF | 1 | 0
*RST: OFF

Example: //Consider preamplifier for auto ranging
 INP:GAIN:AUTO ON

INPut:GAIN:LNA:AUTO <State>

This command includes and excludes the optional low noise amplifier from the auto ranging feature.

Parameters:

<State> ON | OFF | 1 | 0
*RST: OFF

Example: //Allow to turn the amplifier on and off manually
 INP:GAIN:LNA:STAT ON
 INP:GAIN:LNA:AUTO OFF

INPut:GAIN:LNA:STATe <State>

This command turns the optional low noise amplifier on and off.

Note that it is not possible to use the low noise amplifier and the preamplifier at the same time.

Parameters:

<State> ON | OFF | 1 | 0
*RST: OFF

Example: //Turn on low noise preamplifier
INP:GAIN:LNA:STAT ON

Manual operation: See "[Preamplifier](#)" on page 51

INPut:GAIN:STATe <State>

This command turns the preamplifier on and off.

Parameters:

<State> ON | OFF | 1 | 0
*RST: OFF

Example: //Turn on preamplifier
INP:GAIN:STAT ON

Manual operation: See "[Preamplifier](#)" on page 51

[SENSe:]ADJJust:LEVel

Initiates a single (internal) measurement that evaluates and sets the ideal reference level for the current input data and measurement settings. Thus, the settings of the RF attenuation and the reference level are optimized for the signal level. The R&S ESW is not overloaded and the dynamic range is not limited by an S/N ratio that is too small.

Example: ADJ:LEV

Manual operation: See "[Setting the Reference Level Automatically \(Auto Level\)](#)" on page 50

10.4.5 Frequency configuration

[SENSe:]FREQuency:CENTer	116
[SENSe:]FREQuency:CENTer:STEP	117
[SENSe:]FREQuency:CENTer:STEP:LINK	117
[SENSe:]FREQuency:CENTer:STEP:LINK:FACTor	118

[SENSe:]FREQuency:CENTer <Frequency>

Defines the center frequency.

CW, pulsed and VCO measurements:

This command defines or queries (in case of automatic frequency search) the current signal frequency.

Transient measurement:

This command defines the center frequency of the transient measurement.

Parameters:

<Frequency> For the allowed range and f_{max} , refer to the specifications document.

*RST: $f_{max}/2$

Default unit: Hz

Example:

```
FREQ:CENT 100 MHz
```

```
FREQ:CENT:STEP 10 MHz
```

```
FREQ:CENT UP
```

Sets the center frequency to 110 MHz.

Manual operation: See "[Center Frequency](#)" on page 52

[SENSe:]FREQuency:CENTer:STEP <StepSize>

Defines the center frequency step size.

You can increase or decrease the center frequency quickly in fixed steps using the `SENS:FREQ UP` AND `SENS:FREQ DOWN` commands, see [\[SENSe:\]FREQuency:CENTer](#) on page 116.

Parameters:

<StepSize> For f_{max} , refer to the specifications document.

Range: 1 to f_{MAX}

*RST: 0.1 x span

Default unit: Hz

Example:

```
//Set the center frequency to 110 MHz.
```

```
FREQ:CENT 100 MHz
```

```
FREQ:CENT:STEP 10 MHz
```

```
FREQ:CENT UP
```

Manual operation: See "[Center Frequency Stepsize](#)" on page 52

[SENSe:]FREQuency:CENTer:STEP:LINK <CouplingType>

Couples and decouples the center frequency step size to the span or the resolution bandwidth.

Parameters:

<CouplingType> SPAN | RBW | OFF

SPAN

Couples the step size to the span. Available for measurements in the frequency domain.
(for RF spectrum result display)

RBW

Couples the step size to the resolution bandwidth. Available for measurements in the time domain.
(for all result displays except RF spectrum)

OFF

Decouples the step size.

*RST: SPAN

Example: //Couple step size to span
FREQ:CENT:STEP:LINK SPAN

Manual operation: See "[Center Frequency Stepsize](#)" on page 52

[SENSe:]FREQuency:CENTer:STEP:LINK:FACTor <Factor>

Defines a step size factor if the center frequency step size is coupled to the span or the resolution bandwidth.

Parameters:

<Factor> 1 to 100 PCT
*RST: 10
Default unit: PCT

Example: //Couple frequency step size to span and define a step size factor
FREQ:CENT:STEP:LINK SPAN
FREQ:CENT:STEP:LINK:FACT 20PCT

Manual operation: See "[Center Frequency Stepsize](#)" on page 52

10.4.6 Trigger configuration

Useful commands to configure triggered measurements described elsewhere:

- [OUTPut:TRIGger<tp>:DIRection](#) on page 111
- [OUTPut:TRIGger<tp>:LEVel](#) on page 111
- [OUTPut:TRIGger<tp>:OTYPe](#) on page 111
- [OUTPut:TRIGger<tp>:PULSe:IMMediate](#) on page 112
- [OUTPut:TRIGger<tp>:PULSe:LENGth](#) on page 112

TRIGger[:SEQuence]:SOURce	119
TRIGger[:SEQuence]:DTIME	120
TRIGger[:SEQuence]:HOLDoff[:TIME]	120
TRIGger[:SEQuence]:IFPower:HOLDoff	120
TRIGger[:SEQuence]:IFPower:HYSteresis	121
TRIGger[:SEQuence]:LEVel:AM[:ABSolute]	121

TRIGger[:SEquence]:LEVel:AM:RELative.....	122
TRIGger[:SEquence]:LEVel[:EXternal].....	122
TRIGger[:SEquence]:LEVel:FM.....	122
TRIGger[:SEquence]:LEVel:IFPower.....	122
TRIGger[:SEquence]:LEVel:IQPower.....	123
TRIGger[:SEquence]:LEVel:PM.....	123
TRIGger[:SEquence]:LEVel:RFPower.....	123
TRIGger[:SEquence]:SLOPe.....	124
TRIGger[:SEquence]:TIME:RINTerval.....	124

TRIGger[:SEquence]:SOURce <Source>

Selects the trigger source.

For triggering with AF, AM, AMRelative, FM, and PM trigger sources to be successful, the measurement time must cover at least 5 periods of the audio signal. For details on trigger sources, see [Section 5.6.1, "Trigger source settings"](#), on page 53.

Note on external triggers:

If a measurement is configured to wait for an external trigger signal in a remote control program, remote control is blocked until the trigger is received and the program can continue. Make sure that this situation is avoided in your remote control programs.

Parameters:

<Source> See table below.
*RST: IMMEDIATE

Example: //Select external trigger input as source of the trigger signal
TRIG:SOUR EXT

Manual operation: See ["Trigger Source"](#) on page 54
See ["Free Run"](#) on page 54
See ["Ext. Trigger 1/2"](#) on page 54
See ["I/Q Power"](#) on page 54
See ["IF Power"](#) on page 55
See ["FM / AM / PM / RF \(Offline\)"](#) on page 55
See ["Time"](#) on page 55
See ["RF Power"](#) on page 55

Table 10-3: Available trigger sources

SCPI parameter	Trigger source
AF	AF power signal
AM	Corresponds to the RF power signal
EXTernal	Trigger signal from the [Trigger Input] connector.
EXT2 EXT3	Trigger signal from the [Trigger Input/Output] connector. Note: Connector must be configured for "Input".
FM	FM power signal
IFPower	Second intermediate frequency.

SCPI parameter	Trigger source
IMMEDIATE	Free Run trigger.
IQPower	Magnitude of sampled I/Q data. For applications that process I/Q data, such as the I/Q analyzer or optional applications.
PM	PM power signal
RFPower	First intermediate frequency.
TIME	Time interval

TRIGGER[:SEQUENCE]:DTIME <DropoutTime>

Defines the time the input signal must stay below the trigger level before a trigger is detected again.

Parameters:

<DropoutTime> Dropout time of the trigger.
 Range: 0 s to 10.0 s
 *RST: 0 s
 Default unit: S

Manual operation: See "[Drop-Out Time](#)" on page 57

TRIGGER[:SEQUENCE]:HOLDoff[:TIME] <Offset>

Defines the time offset between the trigger event and the start of the measurement (data capturing).

A negative offset is possible for time domain measurements.

For the trigger sources "External" or "IF Power", a common input signal is used for both trigger and gate. Therefore, changes to the gate delay affect the trigger offset as well.

Parameters:

<Offset> Range for measurements in the frequency domain:
 0 s to 30 s
 Range for measurements in the time domain:
 negative sweep time to 30 s
 *RST: 0 s
 Default unit: s

Example: //Define a trigger offset
 TRIG:HOLD 500us

Manual operation: See "[Trigger Offset](#)" on page 56

TRIGGER[:SEQUENCE]:IFPower:HOLDoff <Period>

Defines the holding time before the next trigger event.

Note that this command can be used for **any trigger source**, not just IF Power (despite the legacy keyword).

Note: If you perform gated measurements in combination with the IF Power trigger, the R&S ESW ignores the holding time for frequency sweep, FFT sweep, zero span and I/Q data measurements.

Parameters:

<Period> Range: 0 s to 10 s
 *RST: 0 s
 Default unit: S

Example:

TRIG:SOUR EXT
 Sets an external trigger source.
 TRIG:IFP:HOLD 200 ns
 Sets the holding time to 200 ns.

Manual operation: See "[Trigger Holdoff](#)" on page 57

TRIGger[:SEquence]:IFPower:HYSteresis <Hysteresis>

Defines the trigger hysteresis, which is only available for "IF Power" trigger sources.

Parameters:

<Hysteresis> Range: 3 dB to 50 dB
 *RST: 3 dB
 Default unit: DB

Example:

TRIG:SOUR IFP
 Sets the IF power trigger source.
 TRIG:IFP:HYST 10DB
 Sets the hysteresis limit value.

Manual operation: See "[Hysteresis](#)" on page 56

TRIGger[:SEquence]:LEVel:AM[:ABSolute] <Level>

The command sets the level when RF power signals are used as trigger source.

For triggering to be successful, the measurement time must cover at least 5 periods of the audio signal.

Parameters:

<Level> Range: -100 to +30
 *RST: -20 dBm
 Default unit: dBm

Example:

TRIG:LEV:AM -30 dBm
 Sets the RF power signal trigger threshold to -30 dBm

Manual operation: See "[Trigger Level](#)" on page 56

TRIGger[:SEQuence]:LEVel:AM:RELative <Level>

The command sets the level when AM-modulated signals are used as trigger source.

For triggering to be successful, the measurement time must cover at least 5 periods of the audio signal.

Parameters:

<Level> Range: -100 to +100
 *RST: 0 %
 Default unit: %

Example:

```
TRIG:LEV:AM:REL -20 %  
Sets the AM trigger threshold to -20 %
```

Manual operation: See "[Trigger Level](#)" on page 56

TRIGger[:SEQuence]:LEVel[:EXTernal] <Level>

Defines the level the external signal must exceed to cause a trigger event.

Note that the variable [Input/Output] connectors must be set for use as input using the [OUTPut:TRIGger<tp>:DIRection](#) command.

Parameters:

<Level> Default unit: V

Example:

```
//Define a trigger level of 2 V for an external trigger source  
TRIG:SOUR EXT  
TRIG:LEV 2V
```

Manual operation: See "[Trigger Level](#)" on page 56

TRIGger[:SEQuence]:LEVel:FM <Level>

The command sets the level when FM-modulated signals are used as trigger source.

For triggering to be successful, the measurement time must cover at least 5 periods of the audio signal.

Parameters:

<Level> Range: -10 to +10
 *RST: 0 Hz
 Default unit: MHz

Example:

```
TRIG:LEV:FM 10 kHz  
Sets the FM trigger threshold to 10 kHz
```

Manual operation: See "[Trigger Level](#)" on page 56

TRIGger[:SEQuence]:LEVel:IFPower <TriggerLevel>

Defines the power level at the third intermediate frequency that must be exceeded to cause a trigger event.

Note that any RF attenuation or preamplification is considered when the trigger level is analyzed. If defined, a reference level offset is also considered.

Parameters:

<TriggerLevel> For details on available trigger levels and trigger bandwidths, see the specifications document.
 *RST: -20 dBm
 Default unit: DBM

Example: TRIG:LEV:IFP -30DBM

Manual operation: See "[Trigger Level](#)" on page 56

TRIGger[:SEQuence]:LEVel:IQPower <TriggerLevel>

Defines the magnitude the I/Q data must exceed to cause a trigger event.

Note that any RF attenuation or preamplification is considered when the trigger level is analyzed. If defined, a reference level offset is also considered.

Parameters:

<TriggerLevel> Range: -130 dBm to 30 dBm
 *RST: -20 dBm
 Default unit: DBM

Example: TRIG:LEV:IQP -30DBM

Manual operation: See "[Trigger Level](#)" on page 56

TRIGger[:SEQuence]:LEVel:PM <Level>

The command sets the level when PM-modulated signals are used as trigger source.

For triggering to be successful, the measurement time must cover at least 5 periods of the audio signal.

Parameters:

<Level> Range: -1000 to +1000
 *RST: 0 RAD
 Default unit: RAD | DEG

Example: TRIG:LEV:PM 1.2 RAD
 Sets the PM trigger threshold to 1.2 rad

Manual operation: See "[Trigger Level](#)" on page 56

TRIGger[:SEQuence]:LEVel:RFPower <TriggerLevel>

Defines the power level the RF input must exceed to cause a trigger event. Note that any RF attenuation or preamplification is considered when the trigger level is analyzed. If defined, a reference level offset is also considered.

The input signal must be between 500 MHz and 8 GHz.

Parameters:

<TriggerLevel> For details on available trigger levels and trigger bandwidths, see the specifications document.

*RST: -20 dBm
Default unit: DBM

Example:

TRIG:LEV:RFP -30dBm

Manual operation: See ["Trigger Level"](#) on page 56

TRIGger[:SEQUence]:SLOPe <Type>

Selects the trigger slope.

Parameters:

<Type> **POSitive**
Triggers when the signal rises to the trigger level (rising edge).
NEGative
Triggers when the signal drops to the trigger level (falling edge).
*RST: POSitive

Example:

//Select trigger slope
TRIG:SLOP NEG

Manual operation: See ["Slope"](#) on page 57

TRIGger[:SEQUence]:TIME:RINTerval <Interval>

Defines the repetition interval for the time trigger.

Parameters:

<Interval> numeric value
Range: 2 ms to 5000 s
*RST: 1.0 s
Default unit: S

Example:

TRIG:SOUR TIME
Selects the time trigger input for triggering.
TRIG:TIME:RINT 5
The measurement starts every 5 s.

Manual operation: See ["Repetition Interval"](#) on page 55

10.4.7 Automatic configuration

Commands for automatic configuration described elsewhere.

- [\[SENSe:\]ADJust:LEVel](#) on page 116

[SENSe:]ADJust:ALL	125
[SENSe:]ADJust:CONFigure:LEVel:DURation	125
[SENSe:]ADJust:CONFigure:LEVel:DURation:MODE	125

[SENSe:]ADJust:CONFigure:HYSteresis:LOWer.....	126
[SENSe:]ADJust:CONFigure:HYSteresis:UPPer.....	126
[SENSe:]ADJust:CONFigure:TRIGger.....	127
[SENSe:]ADJust:FREQuency.....	127
[SENSe:]ADJust:SCALe[:Y]:AUTO[:CONTinuous].....	127

[SENSe:]ADJust:ALL

Initiates a measurement to determine and set the ideal settings for the current task automatically (only once for the current measurement).

This includes:

- Center frequency
- Reference level
- Scaling

Example: ADJ:ALL

Manual operation: See "[Adjusting all Determinable Settings Automatically \(Auto All\)](#)" on page 78

[SENSe:]ADJust:CONFigure:LEVel:DURation <Duration>

To determine the ideal reference level, the R&S ESW performs a measurement on the current input data. This command defines the length of the measurement if [SENSe:]ADJust:CONFigure:LEVel:DURation:MODE is set to MANual.

Parameters:

<Duration> Numeric value in seconds
 Range: 0.001 to 16000.0
 *RST: 0.001
 Default unit: s

Example: ADJ:CONF:DUR:MODE MAN
 Selects manual definition of the measurement length.
 ADJ:CONF:LEV:DUR 5ms
 Length of the measurement is 5 ms.

Manual operation: See "[\(Meas Time Manual\)](#)" on page 79

[SENSe:]ADJust:CONFigure:LEVel:DURation:MODE <Mode>

To determine the ideal reference level, the R&S ESW performs a measurement on the current input data. This command selects the way the R&S ESW determines the length of the measurement .

Parameters:

<Mode> **AUTO**
 The R&S ESW determines the measurement length automatically according to the current input data.

MANual

The R&S ESW uses the measurement length defined by `[SENSe:]ADJust:CONFigure:LEVel:DURation` on page 125.

*RST: AUTO

Manual operation: See "[Resetting the Automatic Measurement Time \(Meas Time Auto\)](#)" on page 79
See "[\(Meas Time Manual\)](#)" on page 79

[SENSe:]ADJust:CONFigure:HYSTeresis:LOWer <Threshold>

When the reference level is adjusted automatically using the `[SENSe:]ADJust:LEVel` on page 116 command, the internal attenuators and the preamplifier are also adjusted. To avoid frequent adaptation due to small changes in the input signal, you can define a hysteresis. This setting defines a lower threshold the signal must fall below (compared to the last measurement) before the reference level is adapted automatically.

Parameters:

<Threshold> Range: 0 dB to 200 dB
*RST: +1 dB
Default unit: dB

Example:

`SENS:ADJ:CONF:HYST:LOW 2`

For an input signal level of currently 20 dBm, the reference level is only adjusted when the signal level falls below 18 dBm.

Manual operation: See "[Lower Level Hysteresis](#)" on page 80

[SENSe:]ADJust:CONFigure:HYSTeresis:UPPer <Threshold>

When the reference level is adjusted automatically using the `[SENSe:]ADJust:LEVel` on page 116 command, the internal attenuators and the preamplifier are also adjusted. To avoid frequent adaptation due to small changes in the input signal, you can define a hysteresis. This setting defines an upper threshold the signal must exceed (compared to the last measurement) before the reference level is adapted automatically.

Parameters:

<Threshold> Range: 0 dB to 200 dB
*RST: +1 dB
Default unit: dB

Example:

`SENS:ADJ:CONF:HYST:UPP 2`

Example:

For an input signal level of currently 20 dBm, the reference level is only adjusted when the signal level rises above 22 dBm.

Manual operation: See "[Upper Level Hysteresis](#)" on page 79

[SENSe:]ADJust:CONFigure:TRIGger <State>

Defines the behavior of a triggered measurement when adjusting a setting automatically (using `SENS:ADJ:LEV ON`, for example).

Parameters:

<State> ON | OFF | 0 | 1

ON | 1
(default:) The measurement for adjustment waits for the next trigger.

OFF | 0
The measurement for adjustment is performed without waiting for a trigger (corresponds to "Continue" in manual operation).

*RST: 0

Example:

```
//Use default ref level at 0.00 dBm.
//Define an RF power trigger at -20 dBm
:TRIG:SEQ:SOUR RFP
:TRIG:SEQ:LEV:RFP -20
//Perform adjustment measurement without waiting for trigger
SENS:ADJ:CONF:TRIG OFF
//Perform auto level adjustment
:SENS:ADJ:LEV;*WAI
```

[SENSe:]ADJust:FREQuency

Sets the center frequency to the frequency with the highest signal level in the current frequency range.

Example: ADJ:FREQ

Manual operation: See ["Adjusting the Center Frequency Automatically \(Auto Frequency\)"](#) on page 78

[SENSe:]ADJust:SCALe[:Y]:AUTO[:CONTInuous] <State>

Activates automatic scaling of the y-axis in all diagrams according to the current measurement results. Currently auto-scaling is only available for AF measurements. RF power and RF spectrum measurements are not affected by the auto-scaling.

Parameters:

<State> ON | OFF | 0 | 1

OFF | 0
Switches the function off

ON | 1
Switches the function on

Example: SENS:ADJ:SCAL:Y:AUTO ON

Manual operation: See ["AF Auto Scale"](#) on page 73

10.4.8 Data acquisition

ABORT	128
INITiate<n>:CONMeas	129
INITiate<n>:CONTinuous	129
INITiate:SEQuencer:ABORT	130
INITiate:SEQuencer:IMMediate	130
INITiate:SEQuencer:MODE	130
INITiate<mt>[:IMMediate]	130
[SENSe:]ADEMod:MTIME	131
[SENSe:]ADEMod:REnGth	131
[SENSe:]ADEMod:SET	131
[SENSe:]ADEMod:SPECtrum:BWIDth[:RESolution]	132
[SENSe:]ADEMod:SRATE	133
[SENSe:]AVERage<n>:COUNT	133
[SENSe:]BWIDth:DEMod	133
[SENSe:]BWIDth:DEMod:TYPE	133
[SENSe:]BANDwidth[:RESolution]	134
[SENSe:]SWEep:COUNT	134
[SENSe:]SWEep[:WINDow<n>]:POINTS	135
SYSTem:SEQuencer	135

ABORT

This command aborts the measurement in the current measurement channel and resets the trigger system.

To prevent overlapping execution of the subsequent command before the measurement has been aborted successfully, use the `*OPC` or `*WAI` command after `ABORT` and before the next command.

For details, see the "Remote Basics" chapter in the R&S ESW User Manual.

To abort a sequence of measurements by the Sequencer, use the `INITiate:SEQuencer:ABORT` command.

Note on blocked remote control programs:

If a sequential command cannot be completed, for example because a triggered sweep never receives a trigger, the remote control program will never finish. The remote channel to the R&S ESW is blocked for further commands. In this case, you must interrupt processing on the remote channel first to abort the measurement.

To do so, send a "Device Clear" command from the control instrument to the R&S ESW on a parallel channel to clear all currently active remote channels. Depending on the used interface and protocol, send the following commands:

- **Visa:** `viClear()`
- **GPIB:** `ibclr()`
- **RSIB:** `RSDLLibclr()`

Now you can send the `ABORT` command on the remote channel that runs the measurement.

Example: `ABOR; INIT: IMM`
Aborts the measurement and restarts it.

Usage: Event

INITiate<n>:CONMeas

Restarts a (single) measurement that has been stopped (using `ABORT`) or finished in single measurement mode.

The measurement is restarted at the beginning, not where the previous measurement was stopped.

Suffix:
<n> irrelevant

Usage: Asynchronous command

Manual operation: See "[Continue Single Sweep](#)" on page 61

INITiate<n>:CONTInuous <State>

Controls the measurement mode for an individual channel.

Note that in single measurement mode, you can synchronize to the end of the measurement with `*OPC`, `*OPC?` or `*WAI`. In continuous measurement mode, synchronization to the end of the measurement is not possible. Thus, it is not recommended that you use continuous measurement mode in remote control, as results like trace data or markers are only valid after a single measurement end synchronization.

For details on synchronization see [Remote control via SCPI](#).

Suffix:
<n> 1 | 2
INITiate1 selects single or continuous bargraph measurements.
INITiate2 selects single or continuous scans.

Parameters:
<State> ON | OFF | 0 | 1
ON | 1
Continuous measurement
OFF | 0
Single measurement
***RST:** 1 (some applications can differ)

Example: `INIT:CONT OFF`
Switches the measurement mode to single measurement.
`INIT:CONT ON`
Switches the measurement mode to continuous measurement.

Manual operation: See "[Continuous Sweep / Run Cont](#)" on page 61
See "[Single Sweep / Run Single](#)" on page 61

INITiate:SEQuencer:ABORt

Stops the currently active sequence of measurements.

You can start a new sequence any time using `INITiate:SEQuencer:IMMediate` on page 130.

Usage: Event

INITiate:SEQuencer:IMMediate

Starts a new sequence of measurements by the Sequencer.

Before this command can be executed, the Sequencer must be activated (see `SYSTem:SEQuencer` on page 135).

Example:

```
SYST:SEQ ON
Activates the Sequencer.
INIT:SEQ:MODE SING
Sets single sequence mode so each active measurement is performed once.
INIT:SEQ:IMM
Starts the sequential measurements.
```

INITiate:SEQuencer:MODE <Mode>

Defines the capture mode for the entire measurement sequence and all measurement groups and channels it contains.

Note: To synchronize to the end of a measurement sequence using `*OPC`, `*OPC?` or `*WAI`, use `SINGle` Sequencer mode.

Parameters:

<Mode>

SINGle

Each measurement group is started one after the other in the order of definition. All measurement channels in a group are started simultaneously and performed once. After *all* measurements are completed, the next group is started. After the last group, the measurement sequence is finished.

CONTInuous

Each measurement group is started one after the other in the order of definition. All measurement channels in a group are started simultaneously and performed once. After *all* measurements are completed, the next group is started. After the last group, the measurement sequence restarts with the first one and continues until it is stopped explicitly.

*RST: CONTInuous

INITiate<mt>[:IMMediate]

The command initiates a new measurement.

For a single measurement, the R&S ESW stops measuring when it has reached the end frequency. When you start a continuous measurement, it stops only if you abort it deliberately.

If you are using trace modes MAXHold, MINHold and AVERage, previous results are reset when you restart the measurement.

- **Single measurements**

Synchronization to the end of the measurement is possible with *OPC, *OPC? or *WAI.

- **Continuous measurements**

Synchronization to the end of the measurement is not possible.

It is thus recommended to use a single measurement for remote controlled measurements, because results like trace data or markers are only valid after synchronization.

Suffix:

<mt> INITiate1 initiates a bargraph measurement.
 INITiate2 initiates a scan.

Example: //Start a single scan (with a scan count = 20), and wait until the measurement is done

```
INIT2:CONT OFF
SWE:COUN 20
INIT2;*WAI
```

Usage: Event

Manual operation: See ["Continuous Sweep / Run Cont"](#) on page 61
 See ["Single Sweep / Run Single"](#) on page 61

[SENSe:]ADEMod:MTIME <Time>

Defines the measurement time for Analog Modulation Analysis.

Parameters:

<Time> *RST: 62.5us
 Default unit: S

Example: ADEM:MTIM 62.5us
 Sets the measurement time to 62.5 µs.

Manual operation: See ["Measurement Time \(AQT\)"](#) on page 60

[SENSe:]ADEMod:RLENgth

**[SENSe:]ADEMod:SET <SampleRate>, <RecordLength>, <TriggerSource>,
 <TriggerSlope>, <OffsetSamples>, <NoOfMeas>**

Configures the analog demodulator of the <instrument>.

Parameters:

<SampleRate>	numeric value The frequency at which measurement values are taken from the A/D-converter and stored in I/Q memory. *RST: 8 MHz Default unit: HZ
<RecordLength>	Number of samples to be stored in I/Q memory. Range: 1 to 400001 with AF filter or AF trigger active, 1 to 480001 with both AF filter and AF trigger deactive *RST: 501)
<TriggerSource>	Note: After selecting IF Power, the trigger threshold can be set with the <code>TRIGger[:SEquence]:LEVel:IFPower</code> command. *RST: IMMEDIATE
<TriggerSlope>	POSitive NEGative Used slope of the trigger signal. The value indicated here will be ignored for <trigger source> = IMMEDIATE. *RST: POSitive
<OffsetSamples>	Number of samples to be used as an offset to the trigger signal. The value indicated here is ignored for <trigger source> = "IMMEDIATE". *RST: 0
<NoOfMeas>	Number of repetitions of the measurement to be executed. The value indicated here is especially necessary for the average/maxhold/minhold function. Range: 0 to 32767 *RST: 0

Example:

```
ADEM:SET 8MHz,32000,EXT,POS,-500,30
```

Performs a measurement at:

sample rate = 8 MHz

record length = 32000

trigger source = EXTERNAL

trigger slope = POSitive

offset samples = -500 (500 samples before trigger occurred)

of meas = 30

[SENSe:]ADEMod:SPECTrum:BWIDth[:RESolution] <Bandwidth>

Defines the resolution bandwidth for data acquisition.

From the specified RBW and the demodulation span set by `[SENSe:]ADEMod:SPECTrum:SPAN[:MAXimum]` on page 144 or `[SENSe:]BWIDth:DEMod` on page 133, the required measurement time is calculated. If the available measurement time is not sufficient for the given bandwidth, the measurement time is set to its maximum and the resolution bandwidth is increased to the resulting bandwidth.

Is identical to `SENS:BAND:RES`, see the R&S ESW User Manual.

Parameters:

<Bandwidth> Refer to specifications document.
 *RST: 61.2 kHz
 Default unit: HZ

Example:

`ADEM:SPEC:BAND 61.2kHz`
 Sets the resolution bandwidth to 61.2 kHz.

[SENSe:]ADEMod:SRATe

[SENSe:]AVERAge<n>:COUNT <AverageCount>

Defines the number of measurements that the application uses to average traces.

In case of continuous sweep mode, the application calculates the moving average over the average count.

In case of single sweep mode, the application stops the measurement and calculates the average after the average count has been reached.

Suffix:

<n> irrelevant

Parameters:

<AverageCount> If you set an average count of 0 or 1, the application performs one single measurement in single sweep mode.
 In continuous sweep mode, if the average count is set to 0, a moving average over 10 measurements is performed.
 Range: 0 to 200000
 *RST: 0

[SENSe:]BWIDth:DEMod <Bandwidth>

Sets the bandwidth for Analog Modulation Analysis. Depending on the selected demodulation bandwidth, the <instrument> selects the required sample rate.

Is identical to `SENS:ADEM:BAND:DEM`.

Parameters:

<Bandwidth> *RST: 5 MHz
 Default unit: HZ

Example:

`BAND:DEM 1MHz`
 Sets demodulation bandwidth to 1 MHz

Manual operation: See "[Demodulation Bandwidth](#)" on page 59

[SENSe:]BWIDth:DEMod:TYPE <FilterType>

Defines the type of demodulation filter to be used.

Is identical to `SENS:ADEM:BAND:DEM:TYPE:`

Parameters:

<FilterType> **FLAT**
Standard flat demodulation filter

GAUSS
Gaussian filter for optimized settling behavior

*RST: FLAT

Manual operation: See "[Demodulation Filter](#)" on page 60

[SENSe:]BANDwidth[:RESolution] <Bandwidth>

Defines the resolution bandwidth and decouples the resolution bandwidth from the span.

For statistics measurements, this command defines the **demodulation** bandwidth.

Parameters:

<Bandwidth> refer to specifications document

*RST: RBW: AUTO is set to ON; DBW: 3MHz

Default unit: Hz

Example: BAND 1 MHz
Sets the resolution bandwidth to 1 MHz

Manual operation: See "[Resolution Bandwidth](#)" on page 60

[SENSe:]SWEep:COUNT <SweepCount>

Defines the number of measurements that the application uses to average traces.

In continuous measurement mode, the application calculates the moving average over the average count.

In single measurement mode, the application stops the measurement and calculates the average after the average count has been reached.

Parameters:

<SweepCount> When you set a sweep count of 0 or 1, the R&S ESW performs one single measurement in single measurement mode. In continuous measurement mode, if the sweep count is set to 0, a moving average over 10 measurements is performed.

Range: 0 to 200000

*RST: 0

Example: SWE:COUN 64
Sets the number of measurements to 64.

 INIT:CONT OFF
Switches to single measurement mode.

 INIT;*WAI
Starts a measurement and waits for its end.

Manual operation: See "[Sweep/Average Count](#)" on page 62

[SENSe:]SWEep[:WINDow<n>]:POINTs <SweepPoints>

This command defines the number of measurement points to analyze after a measurement.

Suffix:

<n>

Parameters:

<SweepPoints> <numeric value> (integer)
 Range: 101 to 100001
 *RST: 1001

Example: SWE:POIN 251

Manual operation: See "[Sweep Points](#)" on page 62

SYSTem:SEQuencer <State>

Turns the Sequencer on and off. The Sequencer must be active before any other Sequencer commands (INIT:SEQ...) are executed, otherwise an error occurs.

A detailed programming example is provided in the "Operating Modes" section in the R&S ESW User Manual.

Parameters:

<State> ON | OFF | 0 | 1

ON | 1

The Sequencer is activated and a sequential measurement is started immediately.

OFF | 0

The Sequencer is deactivated. Any running sequential measurements are stopped. Further Sequencer commands (INIT:SEQ...) are not available.

*RST: 0

Example:

SYST:SEQ ON

Activates the Sequencer.

INIT:SEQ:MODE SING

Sets single Sequencer mode so each active measurement is performed once.

INIT:SEQ:IMM

Starts the sequential measurements.

SYST:SEQ OFF

10.4.9 Demodulation settings

• Basic demodulation settings.....	136
• Time domain zoom settings.....	138
• Demodulation spectrum configuration.....	140
• AF filters (Post-Processing).....	144
• AF evaluation scaling.....	150
• RF evaluation scale.....	150
• Units.....	152
• Relative demodulation results.....	152

10.4.9.1 Basic demodulation settings

Commands to configure the demodulation described elsewhere.

- [Section 10.4.9.2, "Time domain zoom settings"](#), on page 138

[SENSe:]ADEMod<n>:AF:COUPling.....	136
[SENSe:]ADEMod:PM:RPOint[:X].....	136
[SENSe:]ADEMod:PM:RPOint[:X]:MODE.....	137
[SENSe:]ADEMod:SQUelch[:STATe].....	137
[SENSe:]ADEMod:SQUelch:LEVel.....	137
CALCulate<n>:FORMat.....	138

[SENSe:]ADEMod<n>:AF:COUPling <Coupling>

Selects the coupling of the AF path of the analyzer in the specified window.

Suffix:

<n> irrelevant

Parameters:

<Coupling> AC | DC
*RST: AC (PM); DC (FM)

Example:

ADEM:AF:COUP DC
Switches on DC coupling.

Manual operation: See "[AF Coupling](#)" on page 64

[SENSe:]ADEMod:PM:RPOint[:X] <Time>

Determines the position where the phase of the PM-demodulated signal is set to 0 rad. The maximum value depends on the measurement time selected in the instrument; this value is output in response to the query ADEM:PM:RPO:X? MAX.

Parameters:

<Time> 0 s to measurement time
*RST: 0 s
Default unit: S

Example:

ADEM:PM:RPO 500us
Sets the position where the phase to 0 rad setting to 500 µs.

[SENSe:]ADEMod:PM:RPOint[:X]:MODE <Mode>

Defines how the reference position in time for 0 rad is determined.

Parameters:

<Mode> MANual | RIGHT

MANual

The time is defined using [\[SENSe:\]ADEMod:PM:RPOint\[:X\]](#) on page 136.

RIGHT

The time of the last measured value is used as the reference position. The time of the last measured value corresponds to the acquisition time, regarding the trigger event and trigger offset, if applicable. If the acquisition time or the trigger values are changed, the reference position is automatically adapted.

*RST: MANual

Example:

ADEMod:MTIM 500us

ADEMod:PM:RPO:MODE RIGHT

Sets the position of the 0 rad phase setting to 500 µs.

[SENSe:]ADEMod:SQUelch[:STATe] <State>

Activates the squelch function, i.e. if the signal falls below a defined threshold (see [\[SENSe:\]ADEMod:SQUelch:LEVel](#) on page 137), the demodulated data is automatically set to 0.

Parameters:

<State> ON | OFF | 0 | 1

OFF | 0

Switches the function off

ON | 1

Switches the function on

Example:

DEM:SQU ON

Signals below the level threshold are squelched.

Manual operation: See "[Squelch State](#)" on page 63

[SENSe:]ADEMod:SQUelch:LEVel <Threshold>

Defines the level threshold below which the demodulated data is set to 0 if squelching is enabled (see [\[SENSe:\]ADEMod:SQUelch\[:STATe\]](#) on page 137).

Parameters:

<Threshold> numeric value

The absolute threshold level

Range: -150 dBm to 30 dBm

*RST: -40 dBm

Example: DEM:SQU:LEV -80
If the signal drops below -80 dBm, the demodulated data is set to 0.

Manual operation: See "[Squelch Level](#)" on page 63

CALCulate<n>:FORMat <Evaluation>

This command activates/deactivates the phase wrap for the specified PM time domain display with DC coupling.

Suffix:
<n> 1..n

Parameters:
<Evaluation> **PHAS**
The phase is wrapped.
UPH
The phase is not wrapped.
*RST: UPH

Example: LAY:ADD? '1',BEL,'XTIM:PM'
Activates PM time domain display. Result: window '2'
INP:COUP DC
Selects DC coupling.
CALC2:FORM PHAS
Selects a wrapped phase display in the PM time domain window.

Manual operation: See "[Phase Wrap On/Off \(PM Time Domain only\)](#)" on page 65

10.4.9.2 Time domain zoom settings

[SENSe:]ADEMod<n>:ZOOM:LENGth.....	138
[SENSe:]ADEMod<n>:ZOOM:LENGth:MODE.....	139
[SENSe:]ADEMod<n>:ZOOM:START.....	139
[SENSe:]ADEMod<n>:ZOOM[:STATe].....	140

[SENSe:]ADEMod<n>:ZOOM:LENGth <Length>

The command allows you to define the length of the time domain zoom area for the analog-demodulated measurement data in the specified window manually. If the length is defined manually using this command, the zoom mode is also set to manual.

Suffix:
<n> [Window](#)

Parameters:
<Length> *RST: sweep time
Default unit: S
Length of the zoom area in seconds.

Example: ADEM:ZOOM:LENG 2s
Zoom mode is set to manual and the zoom length to 2 seconds.

Manual operation: See "[Length](#)" on page 65

[SENSe:]ADEMod<n>:ZOOM:LENGth:MODE <Mode>

The command defines whether the length of the zoom area for the analog-demodulated measurement data is defined automatically or manually in the specified window.

Suffix:

<n> [Window](#)

Parameters:

<Mode> AUTO | MAN

AUTO

(Default:) The number of sweep points is used as the zoom length.

MAN

The zoom length is defined manually using [\[SENSe:\]ADEMod<n>:ZOOM:LENGth](#).

*RST: AUTO

Example: ADEM:ZOOM:LENG:MODE MAN
Zoom function uses the length defined manually.

Manual operation: See "[Length](#)" on page 65

[SENSe:]ADEMod<n>:ZOOM:STARt <Time>

The command selects the start time for the zoomed display of analog-demodulated measurements in the specified window. The maximum value depends on the measurement time, which is set and can be queried with the [\[SENSe:\]ADEMod:MTIME](#) command.

If the zoom function is enabled, the defined number of sweep points are displayed from the start time specified with this command.

Suffix:

<n> [Window](#)

Parameters:

<Time> Range: 0 s to (measurement time – zoom length)
*RST: 0 s
Default unit: S

Example: ADEM:ZOOM:STAT ON
Switches on the zoom function
ADEM:ZOOM:STAR 500us
Sets the starting point of the display to 500 µs.

Manual operation: See "[Start](#)" on page 65

[SENSe:]ADEMod<n>:ZOOM[:STATe] <State>

The command enables or disables the time domain zoom function for the analog-demodulated measurement data in the specified window.

If the zoom function is enabled, the defined number of sweep points are displayed from the start time specified with `[SENSe:]ADEMod<n>:ZOOM:START` on page 139.

If the zoom function is disabled, data reduction is used to adapt the measurement points to the number of points available on the display.

Suffix:

<n> [Window](#)

Parameters:

<State> ON | OFF | 0 | 1
OFF | 0
 Switches the function off
ON | 1
 Switches the function on

Example: `ADEM:ZOOM ON`
 Switches on the zoom function

Manual operation: See ["State"](#) on page 64

10.4.9.3 Demodulation spectrum configuration

- [AF evaluation](#)..... 140
- [RF evaluation](#)..... 143

AF evaluation

These settings are only available for AF Spectrum evaluations, not in the time domain.

<code>DISPlay[:WINDow<n>][:SUBWindow<w>]:TRACe<t>:Y[:SCALE]:PDIVision</code>	140
<code>DISPlay[:WINDow<n>][:SUBWindow<w>]:TRACe<t>:Y[:SCALE]:RPOSition</code>	141
<code>DISPlay[:WINDow<n>][:SUBWindow<w>]:TRACe<t>:Y:SPACing</code>	141
<code>[SENSe:]ADEMod:AF:CENTer</code>	142
<code>[SENSe:]ADEMod:AF:SPAN</code>	142
<code>[SENSe:]ADEMod:AF:SPAN:FULL</code>	142
<code>[SENSe:]ADEMod:AF:START</code>	143
<code>[SENSe:]ADEMod:AF:STOP</code>	143

DISPlay[:WINDow<n>][:SUBWindow<w>]:TRACe<t>:Y[:SCALE]:PDIVision
 <Value>

This remote command determines the grid spacing on the Y-axis for all diagrams, where possible.

In spectrum displays, for example, this command is not available.

Suffix:

<n> [Window](#)

<w>	subwindow Not supported by all applications
<t>	irrelevant
Parameters:	
<Value>	numeric value WITHOUT UNIT (unit according to the result display) Defines the range per division (total range = 10*<Value>) *RST: depends on the result display Default unit: DBM
Example:	DISP:TRAC:Y:PDIV 10 Sets the grid spacing to 10 units (e.g. dB) per division
Manual operation:	See " Dev per Division/ dB per Division " on page 71

DISPlay[:WINDow<n>][:SUBWindow<w>]:TRACe<t>:Y[:SCALe]:RPOSITION
<Position>

Defines the vertical position of the reference level on the display grid (for all traces).

The R&S ESW adjusts the scaling of the y-axis accordingly.

For measurements with the optional external generator control, the command defines the position of the reference value.

Suffix:

<n>	Window
<w>	subwindow Not supported by all applications
<t>	irrelevant

Parameters:

<Position>	*RST: 100 PCT = AF spectrum display; 50 PCT = time display
------------	--

Example: DISP:TRAC:Y:RPOS 50PCT

Manual operation: See "[Reference Value Position](#)" on page 72
See "[Ref Level Position](#)" on page 74

DISPlay[:WINDow<n>][:SUBWindow<w>]:TRACe<t>:Y:SPACing <ScalingType>

Selects the scaling of the y-axis (for all traces, <t> is irrelevant).

For AF spectrum displays, only the parameters "LINear" and "LOGarithmic" are permitted.

Suffix:

<n>	Window
<w>	subwindow

<t>	Trace
Parameters:	
<ScalingType>	LOGarithmic Logarithmic scaling.
	LINear Linear scaling in %.
	LDB Linear scaling in the specified unit.
	PERCent Linear scaling in %.
	*RST: LOGarithmic
Example:	DISP:TRAC:Y:SPAC LIN Selects linear scaling in %.
Manual operation:	See " Deviation " on page 73 See " Scaling " on page 74

[SENSe:]ADEMod:AF:CENTer <Frequency>	
Sets the center frequency for AF spectrum result display.	
Parameters:	
<Frequency>	*RST: 1.25 MHz Default unit: HZ
Manual operation:	See " AF Center " on page 66

[SENSe:]ADEMod:AF:SPAN 	
Sets the span (around the center frequency) for AF spectrum result display.	
The span is limited to DBW/2 (see [SENSe:]BWIDth:DEMod on page 133).	
Parameters:	
	*RST: 9 MHz Default unit: HZ
Example:	ADEM:AF:SPAN 200 kHz Sets the AF span to 200 kHz
Manual operation:	See " AF Span " on page 66

[SENSe:]ADEMod:AF:SPAN:FULL	
Sets the maximum span for AF spectrum result display.	
The maximum span corresponds to DBW/2 (see [SENSe:]BWIDth:DEMod on page 133).	

Example: ADEM:BAND 5 MHz
Sets the demodulation bandwidth to 5 MHz
ADEM:AF:SPAN:FULL
Sets the AF span to 2.5 MHz

Manual operation: See "[AF Full Span](#)" on page 66

[SENSe:]ADEMod:AF:STARt <Frequency>

Sets the start frequency for AF spectrum result display.

Parameters:

<Frequency> *RST: 0 MHz
Default unit: HZ

Example: ADEM:AF:STAR 0 kHz
Sets the AF start frequency to 0 kHz
ADEM:AF:STOP 500 kHz
Sets the AF stop frequency to 500 kHz

Manual operation: See "[AF Start](#)" on page 66

[SENSe:]ADEMod:AF:STOP <Frequency>

Sets the stop frequency for AF spectrum result display.

Parameters:

<Frequency> *RST: 9 MHz
Default unit: HZ

Example: ADEM:AF:STAR 0 kHz
Sets the AF start frequency to 0 kHz
ADEM:AF:STOP 500 kHz
Sets the AF stop frequency to 500 kHz

Manual operation: See "[AF Stop](#)" on page 66

RF evaluation

These settings are only available for RF evaluation, both in time and frequency domain.

Commands to configure the RF evaluation described elsewhere.

- [\[SENSe:\]FREQUENCY:CENTer](#) on page 116
- [\[SENSe:\]BWIDth:DEMod](#) on page 133

[\[SENSe:\]ADEMod:SPECTrum:SPAN:ZOOM](#)..... 143

[\[SENSe:\]ADEMod:SPECTrum:SPAN\[:MAXimum\]](#)..... 144

**[SENSe:]ADEMod:SPECTrum:SPAN:ZOOM **

Sets the span (around the center frequency) for RF spectrum result display.

The span is limited to the demodulation bandwidth (see [SENSe:]BWIDth:DEMod on page 133).

Parameters:

 *RST: 5 MHz
Default unit: HZ

Example:

ADEM:SPEC:SPAN:ZOOM 200 kHz
Sets the rF span to 200 kHz

Manual operation: See "Span" on page 67

[SENSe:]ADEMod:SPECTrum:SPAN[:MAXimum] <FreqRange>

Sets the DBW to the specified value and the span (around the center frequency) of the RF data to be evaluated to its new maximum (the demodulation bandwidth).

Parameters:

<FreqRange> *RST: 5 MHz
Default unit: Hz

Manual operation: See "Span" on page 67
See "RF Full Span" on page 68

10.4.9.4 AF filters (Post-Processing)

The AF filter reduces the evaluated bandwidth of the demodulated signal and can define a weighting function. AF filters are only available for AM or FM time domain evaluations.

[SENSe:]FILTer<n>:AWEighted[:STATe].....	144
[SENSe:]FILTer<n>:AOFF.....	145
[SENSe:]FILTer<n>:CCIR:WEIGhted[:STATe].....	145
[SENSe:]FILTer<n>:CCIR[:UNWeighted][:STATe].....	145
[SENSe:]FILTer<n>:CCIT[:STATe].....	146
[SENSe:]FILTer<n>:DEMPHasis:TCONstant.....	146
[SENSe:]FILTer<n>:DEMPHasis[:STATe].....	146
[SENSe:]FILTer<n>:HPASs:FREQuency[:ABSolute].....	147
[SENSe:]FILTer<n>:HPASs:FREQuency:MANual.....	147
[SENSe:]FILTer<n>:HPASs[:STATe].....	148
[SENSe:]FILTer<n>:LPASs:FREQuency[:ABSolute].....	148
[SENSe:]FILTer<n>:LPASs:FREQuency:MANual.....	148
[SENSe:]FILTer<n>:LPASs:FREQuency:RELative.....	149
[SENSe:]FILTer<n>:LPASs[:STATe].....	149

[SENSe:]FILTer<n>:AWEighted[:STATe] <State>

Activates/deactivates the "A" weighting filter for the specified evaluation.

For details on weighting filters, see "Weighting" on page 69.

Suffix:<n> [Window](#)**Parameters:**

<State> ON | OFF | 0 | 1
OFF | 0
 Switches the function off
ON | 1
 Switches the function on

Example:

FILT:AWE ON
 Activates the A weighting filter.

Manual operation: See ["Weighting"](#) on page 69

[SENSe:]FILTer<n>:AOFF**Suffix:**

<n> 1..n

Manual operation: See ["Deactivating all AF Filters"](#) on page 71

[SENSe:]FILTer<n>:CCIR:WEIGhted[:STATE] <State>

Activates/deactivates the weighted CCIR filter for the specified evaluation.

For details on weighting filters, see ["Weighting"](#) on page 69.

Suffix:<n> [Window](#)**Parameters:**

<State> ON | OFF | 0 | 1
OFF | 0
 Switches the function off
ON | 1
 Switches the function on

Example:

FILT:CCIR:WEIG ON
 Activates the weighted CCIR filter.

Manual operation: See ["Weighting"](#) on page 69

[SENSe:]FILTer<n>:CCIR[:UNWeighted][:STATE] <State>

Activates/deactivates the unweighted CCIR filter in the specified window.

For details on weighting filters, see ["Weighting"](#) on page 69.

Suffix:<n> [Window](#)**Parameters:**

<State> ON | OFF | 0 | 1
OFF | 0
 Switches the function off
ON | 1
 Switches the function on

Example:

FILT:CCIR:UNW ON
 Activates the unweighted CCIR filter.

Manual operation: See ["Weighting"](#) on page 69

[SENSe:]FILTer<n>:CCITt[:STATe] <State>

Suffix:

<n> 1..n

Parameters:

<State>

Manual operation: See ["Weighting"](#) on page 69

[SENSe:]FILTer<n>:DEMPHasis:TCONstant <Value>

Selects the deemphasis for the specified evaluation.

For details on deemphasis refer to ["Deemphasis"](#) on page 70.

Suffix:<n> [Window](#)**Parameters:**

<Value> 25 us | 50 us | 75 us | 750 us
 *RST: 50 us
 Default unit: S

Example:

FILT:DEMP:TCON 750us
 Selects the deemphasis for the demodulation bandwidth range from 800 Hz to 4 MHz with a time constant of 750 µs.

Manual operation: See ["Deemphasis"](#) on page 70

[SENSe:]FILTer<n>:DEMPHasis[:STATe] <State>

Activates/deactivates the selected deemphasis for the specified evaluation.

For details about deemphasis refer to ["Deemphasis"](#) on page 70.

Suffix:<n> [Window](#)**Parameters:**

<State> ON | OFF | 0 | 1
OFF | 0
 Switches the function off
ON | 1
 Switches the function on

Example:

FILT:DEMP ON
 Activates the selected deemphasis.

Manual operation: See "[Deemphasis](#)" on page 70

[SENSe:]FILTer<n>:HPASs:FREQuency[:ABSolute] <Frequency>

Selects the high pass filter type for the specified evaluation.

For details on the high pass filters, refer to "[High Pass](#)" on page 68.

Suffix:<n> [Window](#)**Parameters:**

<Frequency> 20 Hz | 50 Hz | 300 Hz
 *RST: 300Hz
 Default unit: Hz

Example:

FILT:HPAS:FREQ 300Hz
 Selects the high pass filter for the demodulation bandwidth range from 800 Hz to 8 MHz.

Manual operation: See "[High Pass](#)" on page 68

[SENSe:]FILTer<n>:HPASs:FREQuency:MANual <Frequency>

Selects the cutoff frequency of the high pass filter for the specified evaluation.

For details on the high pass filters, refer to "[High Pass](#)" on page 68.

Suffix:<n> [Window](#)**Parameters:**

<Frequency> numeric value
 Range: 0 to 3 MHz
 *RST: 15kHz
 Default unit: HZ

Example:

FILT:HPAS:FREQ:MAN 3MHz
 The AF results are restricted to frequencies lower than 3 MHz.

Manual operation: See "[High Pass](#)" on page 68

[SENSe:]FILTeR<n>:HPASs[:STATe] <State>

Activates/deactivates the selected high pass filter for the specified evaluation.

For details on the high pass filter, refer to "[High Pass](#)" on page 68.

Suffix:

<n> [Window](#)

Parameters:

<State> ON | OFF | 0 | 1
OFF | 0
 Switches the function off
ON | 1
 Switches the function on

Example:

FILT:HPAS ON
 Activates the selected high pass filter.

Manual operation: See "[High Pass](#)" on page 68

[SENSe:]FILTeR<n>:LPASs:FREQuency[:ABSolute] <Frequency>

Selects the absolute low pass filter type for the specified evaluation

For details on the low pass filter, refer to "[Low Pass](#)" on page 69.

Suffix:

<n> [Window](#)

Parameters:

<Frequency> 3kHz | 15kHz | 150kHz
 *RST: 15kHz
 Default unit: HZ

Example:

FILT:LPAS:FREQ 150kHz
 Selects the low pass filter for the demodulation bandwidth range from 400 kHz to 16 MHz.

Manual operation: See "[Low Pass](#)" on page 69

[SENSe:]FILTeR<n>:LPASs:FREQuency:MANual <Frequency>

Selects the cutoff frequency of the low pass filter for the specified evaluation.

For details on the low pass filter, refer to "[Low Pass](#)" on page 69.

Suffix:

<n> [Window](#)

Parameters:

<Frequency> numeric value
 Range: 0 to 3 MHz
 *RST: 15kHz
 Default unit: HZ

Example:

```
FILT:LPAS:FREQ:MAN 150kHz
```

The AF results are restricted to frequencies lower than 150 kHz.

Manual operation: See "[Low Pass](#)" on page 69

[SENSe:]FILTer<n>:LPASs:FREQuency:RELative <Frequency>

Selects the relative low pass filter type for the specified evaluation

For details on the low pass filter, refer to "[Low Pass](#)" on page 69.

Suffix:

<n> [Window](#)

Parameters:

<Frequency> 5PCT | 10PCT | 25PCT
 *RST: 25PCT
 Default unit: PCT

Example:

```
FILT:LPAS:FREQ:REL 25PCT
```

Selects the low pass filter as 25 % of the demodulation bandwidth.

Manual operation: See "[Low Pass](#)" on page 69

[SENSe:]FILTer<n>:LPASs[:STATe] <State>

Activates/deactivates the selected low pass filter for the specified evaluation.

For details on the low pass filter, refer to "[Low Pass](#)" on page 69.

Suffix:

<n> [Window](#)

Parameters:

<State> ON | OFF | 0 | 1
OFF | 0
 Switches the function off
ON | 1
 Switches the function on

Example:

```
FILT:LPAS ON
```

Activates the selected low pass filter.

Manual operation: See "[Low Pass](#)" on page 69

10.4.9.5 AF evaluation scaling

These settings are only available for AF evaluations.

Commands to configure the scale of AF evaluation described elsewhere.

- `[SENSe:]ADJust:SCALe[:Y]:AUTO[:CONTinuous]` on page 127
- `[SENSe:]ADEMod<n>:AF:COUPling` on page 136
- `DISPlay[:WINDow<n>][:SUBWindow<w>]:TRACe<t>:Y[:SCALe]:RPOSition` on page 141
- `DISPlay[:WINDow<n>][:SUBWindow<w>]:TRACe<t>:Y:SPACing` on page 141

`DISPlay[:WINDow<n>][:SUBWindow<w>]:TRACe<t>:Y[:SCALe]:RVALue`..... 150

DISPlay[:WINDow<n>][:SUBWindow<w>]:TRACe<t>:Y[:SCALe]:RVALue <Value>

Defines the reference value assigned to the reference position in the specified window. Separate reference values are maintained for the various displays.

Suffix:

<n>	Window
<w>	subwindow
<t>	irrelevant

Parameters:

<Value> Default unit: DB

Example:

`DISP:TRAC:Y:RVAL 0`

Sets the value assigned to the reference position to 0 Hz

Manual operation: See "Reference Value" on page 72

10.4.9.6 RF evaluation scale

These commands are required for RF evaluations and the result summary.

Commands to configure the scale of RF evaluation described elsewhere.

- `DISPlay[:WINDow<n>][:SUBWindow<w>]:TRACe<t>:Y[:SCALe]:RPOSition` on page 141
- `DISPlay[:WINDow<n>][:SUBWindow<w>]:TRACe<t>:Y:SPACing` on page 141
- `DISPlay[:WINDow<n>][:SUBWindow<w>]:TRACe<t>:Y[:SCALe]:MODE` on page 151

`DISPlay[:WINDow<n>][:SUBWindow<w>]:TRACe<t>:Y[:SCALe]`..... 151

`DISPlay[:WINDow<n>][:SUBWindow<w>]:TRACe<t>:Y[:SCALe]:AUTO ONCE`..... 151

`DISPlay[:WINDow<n>][:SUBWindow<w>]:TRACe<t>:Y[:SCALe]:MODE`..... 151

DISPlay[:WINDow<n>][:SUBWindow<w>]:TRACe<t>:Y[:SCALe] <Range>

Defines the display range of the y-axis (for all traces).

Suffix:

<n>	Window
<w>	subwindow Not supported by all applications
<t>	irrelevant

Parameters:

<Range>	If the y-axis shows the power, the unit is dB with a range from 10 dB to 200 dB. If the y-axis shows the frequency, the unit is Hz with a variable range. *RST: 100 dB (frequency domain), 500 kHz (time domain)
---------	--

Example: DISP:TRAC:Y 110dB

Manual operation: See "Range" on page 74

DISPlay[:WINDow<n>][:SUBWindow<w>]:TRACe<t>:Y[:SCALe]:AUTO ONCE

Automatic scaling of the y-axis is performed once, then switched off again (for all traces).

Suffix:

<n>	Window
<t>	irrelevant

Manual operation: See "Auto Scale Once" on page 74

DISPlay[:WINDow<n>][:SUBWindow<w>]:TRACe<t>:Y[:SCALe]:MODE <Mode>

Selects the type of scaling of the y-axis (for all traces).

When the display update during remote control is off, this command has no immediate effect.

Suffix:

<n>	Window
<w>	subwindow
<t>	irrelevant

Parameters:

<Mode>	ABSolute absolute scaling of the y-axis RELative relative scaling of the y-axis *RST: ABSolute
--------	--

Example: DISP:TRAC:Y:MODE REL

Manual operation: See "Scaling" on page 74

10.4.9.7 Units

UNIT<n>:ANGLE.....	152
UNIT<n>:THD.....	152

UNIT<n>:ANGLE <Unit>

Selects the unit for angles (for PM display, <n> is irrelevant).

Is identical to CALC:UNIT:ANGL

Suffix:

<n> [Window](#)

Parameters:

<Unit> DEG | RAD
*RST: RAD

Example: UNIT:ANGL DEG

Manual operation: See "Phase Unit (Rad/Deg)" on page 75

UNIT<n>:THD <Mode>

Selects the unit for THD measurements (<n> is irrelevant).

Is identical to CALC:UNIT:THD

Suffix:

<n> [Window](#)

Parameters:

<Mode> DB | PCT
*RST: DB

Example: UNIT:THD PCT

Manual operation: See "THD Unit (%/ DB)" on page 75

10.4.9.8 Relative demodulation results

CONFigure:ADEMod:RESults:AM:DETEctor<det>:REFerence.....	153
CONFigure:ADEMod:RESults:FM:DETEctor<det>:REFerence.....	153
CONFigure:ADEMod:RESults:PM:DETEctor<det>:REFerence.....	153
CONFigure:ADEMod:RESults:AM:DETEctor<det>:STATe.....	153
CONFigure:ADEMod:RESults:FM:DETEctor<det>:STATe.....	153
CONFigure:ADEMod:RESults:PM:DETEctor<det>:STATe.....	153
CONFigure:ADEMod:RESults:AM:DETEctor<det>:REFerence:MEASStoref<t>.....	154
CONFigure:ADEMod:RESults:FM:DETEctor<det>:REFerence:MEASStoref<t>.....	154

CONFigure:ADEMod:RESults:PM:DETEctor<det>:REFerence:MEASStoref<t>	154
CONFigure:ADEMod:RESults:AM:DETEctor<det>:MODE	154
CONFigure:ADEMod:RESults:FM:DETEctor<det>:MODE	154
CONFigure:ADEMod:RESults:PM:DETEctor<det>:MODE	154
CONFigure:ADEMod:RESults:UNIT	155

CONFigure:ADEMod:RESults:AM:DETEctor<det>:REFerence <RefValue>

CONFigure:ADEMod:RESults:FM:DETEctor<det>:REFerence <RefValue>

CONFigure:ADEMod:RESults:PM:DETEctor<det>:REFerence <RefValue>

Defines the reference value to be used for relative demodulation results and recalculates the results. If necessary, the detector is activated.

A reference value 0 would provide infinite results and is thus automatically corrected to 0.1.

Suffix:

<det> Detector function used for relative demodulation

Parameters:

<RefValue> double value

The unit depends on the demodulation type:

ACV: V

AM: %

FM: Hz

PM: depends on [UNIT<n>:ANGLE](#) setting

*RST: 1.0

Default unit: RAD

Example: See [CONFigure:ADEMod:RESults:PM:DETEctor<det>:STATE](#) on page 153

Manual operation: See "Reference Value" on page 77

CONFigure:ADEMod:RESults:AM:DETEctor<det>:STATE <State>

CONFigure:ADEMod:RESults:FM:DETEctor<det>:STATE <State>

CONFigure:ADEMod:RESults:PM:DETEctor<det>:STATE <State>

Activates relative demodulation for the selected detector. If activated, the demodulated result is set in relation to the reference value defined by [CONFigure:ADEMod:RESults:PM:DETEctor<det>:REFerence](#).

Suffix:

<det> Detector function used for relative demodulation

Parameters:

<State> ON | OFF | 0 | 1

OFF | 0

Switches the function off

ON | 1

Switches the function on

Example:

```
CONF:ADEM:RES:PM:DET2:STAT ON
```

Activates relative demodulation for the negative peak detector.

```
CONF:ADEM:RES:UNIT PCT
```

Defines the unit for relative values as percent.

```
CONF:ADEM:RES:PM:DET2:REF 1.415%
```

Sets the reference value for the negative peak detector to 1.415 %.

```
CONF:ADEM:RES:PM:DET2:MODE AVER
```

Sets the negative peak detector to average mode.

```
CONF:ADEM:RES:PM:DET2:REF:MEAS2
```

Sets the reference value for the negative peak detector to the average of the currently calculated value and the previous reference value on trace 2.

Manual operation: See ["State"](#) on page 77

CONFigure:ADEMod:RESults:AM:DETEctor<det>:REFerence:MEASStoref<t>

CONFigure:ADEMod:RESults:FM:DETEctor<det>:REFerence:MEASStoref<t>

CONFigure:ADEMod:RESults:PM:DETEctor<det>:REFerence:MEASStoref<t>

Sets the reference value to be used for relative demodulation results to the currently measured value on the specified trace *for all relative detectors*.

If necessary, the detectors are activated.

A reference value 0 would provide infinite results and is thus automatically corrected to 0.1.

Suffix:

<det> irrelevant

<t> 1..n
[Trace](#)

Example: See [CONFigure:ADEMod:RESults:PM:DETEctor<det>:STATe](#) on page 153

Manual operation: See ["Meas -> Reference"](#) on page 77

CONFigure:ADEMod:RESults:AM:DETEctor<det>:MODE <Mode>

CONFigure:ADEMod:RESults:FM:DETEctor<det>:MODE <Mode>

CONFigure:ADEMod:RESults:PM:DETEctor<det>:MODE <Mode>

Defines the mode with which the demodulation result is determined.

Suffix:

<det> Detector function used for relative demodulation

Parameters:

<Mode> **WRITE**

Overwrite mode: the detector value is overwritten by each sweep. This is the default setting.

AVERage

The average result is determined over all sweeps.

MAXHold

The maximum value is determined over several sweeps and displayed. The R&S ESW saves each result only if the new value is greater than the previous one.

*RST: WRITe

Example: See [CONFigure:ADEMod:RESults:PM:DETEctor<det>:STATe](#) on page 153

Manual operation: See ["Mode"](#) on page 76

CONFigure:ADEMod:RESults:UNIT <Unit>

Selects the unit for relative demodulation results.

Parameters:

<Unit> PCT | DB
*RST: PCT

Example: CONF:ADEM:RES:AM:DET2:STAT ON
Activates relative demodulation for the negative peak detector.
CONF:ADEM:RES:AM:DET2:MODE AVER
Sets the negative peak detector to average mode.
CONF:ADEM:RES:UNIT PCT
Defines the unit for relative values as percent.
CONF:ADEM:RES:AM:DET2:REF 1.415%
Sets the reference value for relative results to 1.415 %.

Manual operation: See ["Relative Unit"](#) on page 75

10.5 Result display configuration

- [General window commands](#)..... 155
- [Screen layout](#)..... 156

10.5.1 General window commands

Note that the suffix <n> always refers to the window in the **currently selected measurement channel**.

[DISPlay:FORMat](#)..... 156
[DISPlay\[:WINDow<n>\]:SIZE](#)..... 156

DISPlay:FORMat <Format>

Determines which tab is displayed.

Parameters:

<Format>

SPLit

Displays the MultiView tab with an overview of all active channels

SINGle

Displays the measurement channel that was previously focused.

*RST: SING

Example:

```
DISP:FORM SPL
```

DISPlay[:WINDow<n>]:SIZE <Size>

Maximizes the size of the selected result display window *temporarily*. To change the size of several windows on the screen permanently, use the `LAY:SPL` command (see [LAYout:SPLitter](#) on page 159).

Suffix:

<n>

Window

Parameters:

<Size>

LARGE

Maximizes the selected window to full screen. Other windows are still active in the background.

SMALI

Reduces the size of the selected window to its original size. If more than one measurement window was displayed originally, these are visible again.

*RST: SMALI

Example:

```
DISP:WIND2:SIZE LARG
```

10.5.2 Screen layout

The following commands are required to change the evaluation type and rearrange the screen layout for a measurement channel as you do using the SmartGrid in manual operation. Since the available evaluation types depend on the selected application, some parameters for the following commands also depend on the selected measurement channel.

Note that the suffix <n> always refers to the window in the **currently selected measurement channel**.

LAYout:ADD[:WINDow]?	157
LAYout:CATalog[:WINDow]?	158
LAYout:IDENtify[:WINDow]?	158
LAYout:REMove[:WINDow]	159
LAYout:REPLace[:WINDow]	159

LAYout:SPLitter	159
LAYout:WINDow<n>:ADD?	161
LAYout:WINDow<n>:IDENTify?	161
LAYout:WINDow<n>:REMOve	162
LAYout:WINDow<n>:REPLace	162

LAYout:ADD[:WINDow]? <WindowName>, <Direction>, <WindowType>

Adds a window to the display in the active channel.

Is always used as a query so that you immediately obtain the name of the new window as a result.

To replace an existing window, use the [LAYout:REPLace\[:WINDow\]](#) command.

Query parameters:

<WindowName>	String containing the name of the existing window the new window is inserted next to. By default, the name of a window is the same as its index. To determine the name and index of all active windows, use the LAYout:CATalog[:WINDow]? query.
<Direction>	LEFT RIGHT ABOVE BELOW Direction the new window is added relative to the existing window.
<WindowType>	text value Type of result display (evaluation method) you want to add. See the table below for available parameter values.

Return values:

<NewWindowName>	When adding a new window, the command returns its name (by default the same as its number) as a result.
-----------------	---

Example: `LAY:ADD? '1',BEL,'XTIM:AM:RElative[:TDOMain]'`
Adds an "AM Time Domain" display below window 1.

Usage: Query only

Manual operation: See ["AM Time Domain"](#) on page 13
See ["FM Time Domain"](#) on page 14
See ["PM Time Domain"](#) on page 15
See ["AM Spectrum"](#) on page 16
See ["FM Spectrum"](#) on page 17
See ["PM Spectrum"](#) on page 18
See ["RF Time Domain"](#) on page 19
See ["RF Spectrum"](#) on page 20
See ["Result Summary"](#) on page 21
See ["Marker Table"](#) on page 23
See ["Marker Peak List"](#) on page 23

Table 10-4: <WindowType> parameter values for AnalogDemod application

Parameter value	Window type
MTABle	"Marker table"
PEAKlist	"Marker peak list"
RSUMmary	"Result summary"
'XTIM:AM'	"RF Time Domain" (= RF power)
'XTIM:AM:RELative'	"AM Time Domain"
'XTIM:AM:RELative:AFSPec- trum'	"AM Spectrum"
'XTIM:FM'	"FM Time Domain"
'XTIM:FM:AFSPpectrum'	"FM Spectrum"
'XTIM:PM'	"PM Time Domain"
'XTIM:PM:AFSPpectrum'	"PM Spectrum"
'XTIM:SPEctrum'	"RF Spectrum"

LAYout:CATalog[:WINDow]?

Queries the name and index of all active windows in the active channel from top left to bottom right. The result is a comma-separated list of values for each window, with the syntax:

<WindowName_1>,<WindowIndex_1>..<<WindowName_n>,<WindowIndex_n>

Return values:

<WindowName> string
Name of the window.
In the default state, the name of the window is its index.

<WindowIndex> **numeric value**
Index of the window.

Example:

LAY:CAT?

Result:

'2',2,'1',1

Two windows are displayed, named '2' (at the top or left), and '1' (at the bottom or right).

Usage: Query only

LAYout:IDENTify[:WINDow]? <WindowName>

Queries the **index** of a particular display window in the active channel.

Query parameters:

<WindowName> String containing the name of a window.

Return values:

<WindowIndex> Index number of the window.

Example:

```
LAY:IDEN:WIND? '2'
```

Queries the index of the result display named '2'.

Response:

```
2
```

Usage:

Query only

LAYout:REMove[:WINDow] <WindowName>

Removes a window from the display in the active channel.

Setting parameters:

<WindowName> String containing the name of the window. In the default state, the name of the window is its index.

Example:

```
LAY:REM '2'
```

Removes the result display in the window named '2'.

Usage:

Setting only

LAYout:REPLace[:WINDow] <WindowName>, <WindowType>

Replaces the window type (for example from "Diagram" to "Result Summary") of an already existing window in the active channel while keeping its position, index and window name.

To add a new window, use the [LAYout:ADD\[:WINDow\]?](#) command.

Setting parameters:

<WindowName> String containing the name of the existing window.
By default, the name of a window is the same as its index. To determine the name and index of all active windows in the active channel, use the [LAYout:CATalog\[:WINDow\]?](#) query.

<WindowType> Type of result display you want to use in the existing window.
See [LAYout:ADD\[:WINDow\]?](#) on page 157 for a list of available window types.

Example:

```
LAY:REPL:WIND '1',MTAB
```

Replaces the result display in window 1 with a marker table.

Usage:

Setting only

LAYout:SPLitter <Index1>, <Index2>, <Position>

Changes the position of a splitter and thus controls the size of the windows on each side of the splitter.

Note that windows must have a certain minimum size. If the position you define conflicts with the minimum size of any of the affected windows, the command does not work, but does not return an error.

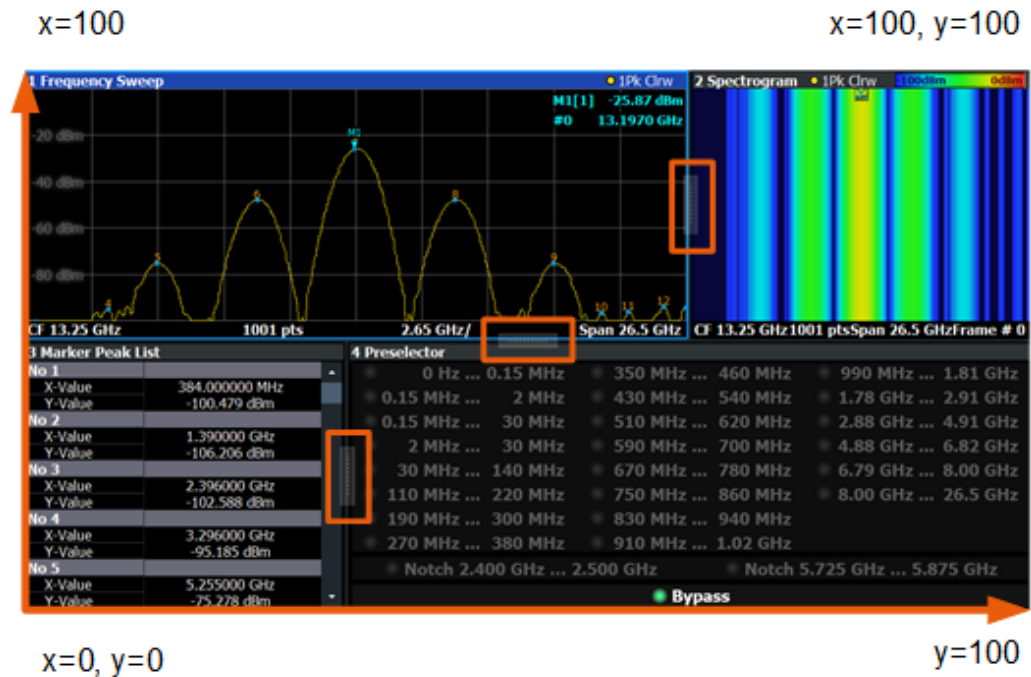

Figure 10-1: SmartGrid coordinates for remote control of the splitters

Setting parameters:

- <Index1> The index of one window the splitter controls.
- <Index2> The index of a window on the other side of the splitter.
- <Position> New vertical or horizontal position of the splitter as a fraction of the screen area (without channel and status bar and softkey menu).
The point of origin ($x = 0$, $y = 0$) is in the lower left corner of the screen. The end point ($x = 100$, $y = 100$) is in the upper right corner of the screen. (See Figure 10-1.)
The direction in which the splitter is moved depends on the screen layout. If the windows are positioned horizontally, the splitter also moves horizontally. If the windows are positioned vertically, the splitter also moves vertically.

Range: 0 to 100

Example:

LAY:SPL 1,3,50

Moves the splitter between window 1 ("Frequency Sweep") and 3 ("Marker Table") to the center (50%) of the screen, i.e. in the figure above, to the left.

Example: `LAY:SPL 1,4,70`
 Moves the splitter between window 1 ('Frequency Sweep') and 3 ('Marker Peak List') towards the top (70%) of the screen. The following commands have the exact same effect, as any combination of windows above and below the splitter moves the splitter vertically.
`LAY:SPL 3,2,70`
`LAY:SPL 4,1,70`
`LAY:SPL 2,1,70`

Usage: Setting only

LAYout:WINDow<n>:ADD? <Direction>,<WindowType>

Adds a measurement window to the display. Note that with this command, the suffix <n> determines the existing window next to which the new window is added. Unlike [LAYout:ADD\[:WINDow\]?](#), for which the existing window is defined by a parameter.

To replace an existing window, use the [LAYout:WINDow<n>:REPLace](#) command.

Is always used as a query so that you immediately obtain the name of the new window as a result.

Suffix:

<n> [Window](#)

Query parameters:

<Direction> LEFT | RIGHT | ABOVE | BELOW

<WindowType> Type of measurement window you want to add.
 See [LAYout:ADD\[:WINDow\]?](#) on page 157 for a list of available window types.

Return values:

<NewWindowName> When adding a new window, the command returns its name (by default the same as its number) as a result.

Example: `LAY:WIND1:ADD? LEFT,MTAB`
Result:
`'2'`
 Adds a new window named '2' with a marker table to the left of window 1.

Usage: Query only

LAYout:WINDow<n>:IDENTify?

Queries the **name** of a particular display window (indicated by the <n> suffix) in the active channel.

Note: to query the **index** of a particular window, use the [LAYout:IDENTify\[:WINDow\]?](#) command.

Suffix:	
<n>	Window
Return values:	
<WindowName>	String containing the name of a window. In the default state, the name of the window is its index.
Example:	LAY:WIND2:IDEN? Queries the name of the result display in window 2. Response: '2'
Usage:	Query only

LAYout:WINDow<n>:REMOve

Removes the window specified by the suffix <n> from the display in the active channel.
The result of this command is identical to the [LAYout:REMOve\[:WINDow\]](#) command.

Suffix:	
<n>	Window
Example:	LAY:WIND2:REM Removes the result display in window 2.
Usage:	Event

LAYout:WINDow<n>:REPLace <WindowType>

Changes the window type of an existing window (specified by the suffix <n>) in the active channel.

The effect of this command is identical to the [LAYout:REPLace\[:WINDow\]](#) command.

To add a new window, use the [LAYout:WINDow<n>:ADD?](#) command.

Suffix:	
<n>	Window
Setting parameters:	
<WindowType>	Type of measurement window you want to replace another one with. See LAYout:ADD[:WINDow]? on page 157 for a list of available window types.
Example:	LAY:WIND2:REPL MTAB Replaces the result display in window 2 with a marker table.
Usage:	Setting only

10.6 Measurement results

- [Result retrieval](#)..... 163
- [Retrieving result summary values](#)..... 169
- [Trace export](#)..... 173

10.6.1 Result retrieval

Commands to retrieve results described elsewhere.

- [\[SENSe:\]ADEMod:PM:RPoint\[:X\]](#) on page 136

[SENSe:]ADEMod:AM[:ABSolute][:TDOMain][:TYPE]?.....	163
[SENSe:]ADEMod:AM:RELative[:TDOMain][:TYPE]?.....	163
[SENSe:]ADEMod:AM:RELative:AFSPectrum[:TYPE]?.....	163
[SENSe:]ADEMod:FM[:TDOMain][:TYPE]?.....	163
[SENSe:]ADEMod:FM:AFSPectrum[:TYPE]?.....	163
[SENSe:]ADEMod:PM[:TDOMain][:TYPE]?.....	163
[SENSe:]ADEMod:PM:AFSPectrum[:TYPE]?.....	163
[SENSe:]ADEMod:SPEctrum[:TYPE].....	163
[SENSe:]ADEMod:AM[:ABSolute][:TDOMain]:RESult?.....	164
[SENSe:]ADEMod:AM:RELative[:TDOMain]:RESult?.....	164
[SENSe:]ADEMod:AM:RELative:AFSPectrum:RESult?.....	165
[SENSe:]ADEMod:FM[:TDOMain]:RESult?.....	165
[SENSe:]ADEMod:FM:AFSPectrum:RESult?.....	165
[SENSe:]ADEMod:PM[:TDOMain]:RESult?.....	165
[SENSe:]ADEMod:PM:AFSPectrum:RESult?.....	165
[SENSe:]ADEMod:SPEctrum:RESult?.....	165
FORMat[:DATA].....	166
TRACe<n>[:DATA].....	167
CALCulate<n>:DELTaMarker<m>:X.....	167
CALCulate<n>:DELTaMarker<m>:Y?.....	167
CALCulate<n>:MARKer<m>:X.....	168
CALCulate<n>:MARKer<m>:Y?.....	168

```

[SENSe:]ADEMod:AM[:ABSolute][:TDOMain][:TYPE]? <TraceMode>
[SENSe:]ADEMod:AM:RELative[:TDOMain][:TYPE]? <TraceMode>
[SENSe:]ADEMod:AM:RELative:AFSPectrum[:TYPE]? <TraceMode>
[SENSe:]ADEMod:FM[:TDOMain][:TYPE]? <TraceMode>
[SENSe:]ADEMod:FM:AFSPectrum[:TYPE]? <TraceMode>
[SENSe:]ADEMod:PM[:TDOMain][:TYPE]? <TraceMode>
[SENSe:]ADEMod:PM:AFSPectrum[:TYPE]? <TraceMode>
[SENSe:]ADEMod:SPEctrum[:TYPE] <TraceMode>...

```

Selects the trace modes of the evaluated signal to be measured simultaneously. For each of the six available traces a mode can be defined.

The trace modes are configured identically for all windows with a specific evaluation. The following table indicates which command syntax refers to which evaluation method.

Command syntax	Evaluation method
AM[:ABSolute][:TDOMain]	RF time domain
AM:RELative[:TDOMain]	AM time domain
AM:RELative:AFSPectrum	AM spectrum (relative)
FM[:TDOMain]	FM time domain
FM:AFSPectrum	FM spectrum
PM[:TDOMain]	PM time domain
PM:AFSPectrum	PM spectrum
SPECtrum	RF spectrum

Parameters:

<TraceMode>

WRITE | AVERage | MAXHold | MINHold | VIEW | OFF

WRITE

Overwrite mode: the trace is overwritten by each sweep. This is the default setting.

AVERage

The average is formed over several sweeps.

MAXHold

The maximum value is determined over several sweeps and displayed. The R&S ESW saves the sweep result in the trace memory only if the new value is greater than the previous one.

MINHold

The minimum value is determined from several measurements and displayed. The R&S ESW saves the sweep result in the trace memory only if the new value is lower than the previous one.

VIEW

The current contents of the trace memory are frozen and displayed.

OFF

Hides the selected trace.

*RST: WRITE,OFF,OFF,OFF,OFF,OFF

Example:

ADEM:AM AVER,MAXH,MINH,OFF,OFF,OFF

Determines average, max hold and min hold values simultaneously for the traces 1-3 of the RF time domain evaluation.

ADEM:AM WRIT,OFF,OFF,OFF,OFF,OFF

Determines only the current measurement values for trace 1.

ADEM:AM OFF,OFF,OFF,OFF,OFF,OFF

Switches AM demodulation off.

[SENSe:]ADEMod:AM[:ABSolute][:TDOMain]:RESult? <TraceMode>

[SENSe:]ADEMod:AM:RELative[:TDOMain]:RESult? <TraceMode>

[SENSe:]ADEMod:AM:RElative:AFSPepectrum:RESult? <TraceMode>
[SENSe:]ADEMod:FM[:TDOMain]:RESult? <TraceMode>
[SENSe:]ADEMod:FM:AFSPepectrum:RESult? <TraceMode>
[SENSe:]ADEMod:PM[:TDOMain]:RESult? <TraceMode>
[SENSe:]ADEMod:PM:AFSPepectrum:RESult? <TraceMode>
[SENSe:]ADEMod:SPEctrum:RESult? <TraceMode>

Reads the result data of the evaluated signal in the specified trace mode. The data format of the output data block is defined by the **FORMat [: DATA]** on page 166).

The trace results are configured for a specific evaluation. The following table indicates which command syntax refers to which evaluation method, as well as the output unit of the results.

Command syntax	Evaluation method	Output unit
ACV[:TDOMain]	AC-Video time domain	V
ACV:AFSPepectrum	AC-Video spectrum	V
AM[:ABSolute][:TDOMain]	RF time domain	dBm
AM:RElative[:TDOMain]	AM time domain	%
AM:RElative:AFSPepectrum	AM spectrum	%
FM[:TDOMain]	FM time domain	kHz
FM:AFSPepectrum	FM spectrum	kHz
PM[:TDOMain]	PM time domain	rad or °
PM:AFSPepectrum	PM spectrum	rad or °
SPEctrum	RF spectrum	dBm (logarithmic display) or V (linear display).

Query parameters:

<TraceMode> WRITe | AVERage | MAXHold | MINHold

Return values:

<TraceModeResult> The specified trace mode must be one of those configured by **SENS:ADEM:<Evaluation>:TYPE**, see **[SENSe:]ADEMod:SPEctrum[:TYPE]** on page 163. Otherwise a query error is generated.

Example: ADEM:AM AVER,MAXH,MINH
 Sets up RF time domain results to be measured
 INIT; *WAI
 Starts measurement and waits for sync
 FORM ASC
 Selects output format
 ADEM:AM:RES? AVER
 Reads RF time domain average results
 ADEM:AM:RES? MAXH
 Reads RF time domain max hold results
 ADEM:AM:RES? MINH
 Reads RF time domain min hold results

Usage: Query only

FORMat[:DATA] <Format>[, <BitLength>]

Selects the data format that is used for transmission of trace data from the R&S ESW to the controlling computer.

Note that the command has no effect for data that you send to the R&S ESW. The R&S ESW automatically recognizes the data it receives, regardless of the format.

Parameters:

<Format>

ASCii

ASCII format, separated by commas.

This format is almost always suitable, regardless of the actual data format. However, the data is not as compact as other formats can be.

REAL

Floating-point numbers (according to IEEE 754) in the "definite length block format".

The format setting **REAL** is used for the binary transmission of trace data.

<BitLength>

Length in bits for floating-point results

16

16-bit floating-point numbers.

Compared to **REAL, 32** format, half as many numbers are returned.

32

32-bit floating-point numbers

For I/Q data, 8 bytes per sample are returned for this format setting.

64

64-bit floating-point numbers

Compared to **REAL, 32** format, twice as many numbers are returned.

Example: FORM REAL, 32

TRACe<n>[:DATA]

This command queries current trace data and measurement results.

The data format depends on `FORMat[:DATA]` on page 166.

Suffix:

<n> [Window](#)

Query parameters:

<ResultType> Selects the type of result to be returned.

TRACE1 | ... | TRACE6

Returns the trace data for the corresponding trace.

The trace data consists of a list of measured power levels. The number of power levels in the list depends on the currently selected number of sweep points. The unit depends on the measurement and on the configured unit.

For the auto peak detector, the command returns positive peak values only. (To retrieve negative peak values, define a second trace with a negative peak detector.)

Example:

`TRAC? TRACE3`

Queries the data of trace 3.

CALCulate<n>:DELTamarker<m>:X <Position>

Moves a delta marker to a particular coordinate on the x-axis.

If necessary, the command activates the delta marker and positions a reference marker to the peak power.

Suffix:

<n> [Window](#)

<m> [Marker](#)

Parameters:

<Position> Numeric value that defines the marker position on the x-axis. The position is relative to the reference marker.

A query returns the absolute position of the delta marker.

Range: The value range and unit depend on the measurement and scale of the x-axis.

Default unit: HZ

Example:

`CALC:DELT:X?`

Outputs the absolute x-value of delta marker 1.

CALCulate<n>:DELTamarker<m>:Y?

Queries the result at the position of the specified delta marker.

Suffix:

<n> 1..n

<m> 1..n

Return values:

<Result> Result at the position of the delta marker.
The unit is variable and depends on the one you have currently set.
Default unit: DBM

Usage: Query only

CALCulate<n>:MARKer<m>:X <Position>

Moves a marker to a specific coordinate on the x-axis.

If necessary, the command activates the marker.

If the marker has been used as a delta marker, the command turns it into a normal marker.

Suffix:

<n> [Window](#)

<m> [Marker](#)

Parameters:

<Position> Numeric value that defines the marker position on the x-axis.
The unit depends on the result display.
Range: The range depends on the current x-axis range.
Default unit: Hz

Example: `CALC:MARK2:X 1.7MHz`
Positions marker 2 to frequency 1.7 MHz.

Manual operation: See "[Marker Table](#)" on page 23
See "[Marker Peak List](#)" on page 23

CALCulate<n>:MARKer<m>:Y?

Queries the result at the position of the specified marker.

Suffix:

<n> 1..n

<m> 1..n

Return values:

<Result> Default unit: DBM

Usage: Query only

Manual operation: See "[Marker Table](#)" on page 23
See "[Marker Peak List](#)" on page 23

10.6.2 Retrieving result summary values

The result summary contains measurement values that are calculated from the trace data.

For details see "Result Summary" on page 21.

CALCulate<n>:MARKer<m>:FUNction:ADEMod:AFRequency[:RESult<t>]?	169
CALCulate<n>:MARKer<m>:FUNction:ADEMod:AM[:RESult<t>]?	169
CALCulate<n>:MARKer<m>:FUNction:ADEMod:FM[:RESult<t>]?	169
CALCulate<n>:MARKer<m>:FUNction:ADEMod:PM[:RESult<t>]?	169
CALCulate<n>:MARKer<m>:FUNction:ADEMod:AM[:RESult<t>]:RELative?	170
CALCulate<n>:MARKer<m>:FUNction:ADEMod:FM[:RESult<t>]:RELative?	170
CALCulate<n>:MARKer<m>:FUNction:ADEMod:PM[:RESult<t>]:RELative?	170
CALCulate<n>:MARKer<m>:FUNction:ADEMod:CARRier[:RESult<t>]?	171
CALCulate<n>:MARKer<m>:FUNction:ADEMod:DISTortion[:WRITe]:RESult<t>?	171
CALCulate<n>:MARKer<m>:FUNction:ADEMod:FERRor[:RESult<t>]?	171
CALCulate<n>:MARKer<m>:FUNction:ADEMod:SINad:RESult<t>?	172
CALCulate<n>:MARKer<m>:FUNction:ADEMod:THD:RESult<t>?	172

CALCulate<n>:MARKer<m>:FUNction:ADEMod:AFRequency[:RESult<t>]?

Queries the modulation (audio) frequency for the demodulation method in the specified window.

Suffix:

<n>	Window
<m>	irrelevant
<t>	Trace

Return values:

<ModFreq> Modulation frequency in Hz.

Usage: Query only

CALCulate<n>:MARKer<m>:FUNction:ADEMod:AM[:RESult<t>]? <MeasType>
CALCulate<n>:MARKer<m>:FUNction:ADEMod:FM[:RESult<t>]? <MeasType>
CALCulate<n>:MARKer<m>:FUNction:ADEMod:PM[:RESult<t>]? <MeasType>

Queries the current value of the demodulated signal for the specified trace (as displayed in the "Result Summary" in manual operation).

Note that all windows with the same evaluation method have the same traces, thus the window is irrelevant.

Suffix:

<n>	Window
<m>	irrelevant
<t>	Trace

Query parameters:

<MeasType> PPEak | MPEak | MIDDLE | RMS

PPEak

Positive peak (+PK)

MPEak | NPEak

Negative peak (-PK)

MIDDLEAverage of positive and negative peaks \pm PK/2**RMS**

Root mean square value

Return values:

<MeasTypeResult>

Example:`CALC:FEED 'XTIM:PM:TDOM'`

Switches on the PM time domain result display.

`DISP:TRAC ON`

Switches on the trace.

`CALC:MARK:FUNC:ADEM:PM? PPE`

Queries the peak value of the demodulated PM trace.

Usage:

Query only

CALCulate<n>:MARKer<m>:FUNCTION:ADEMod:AM[:RESult<t>]:RELative?

<MeasType>

CALCulate<n>:MARKer<m>:FUNCTION:ADEMod:FM[:RESult<t>]:RELative?

<MeasType>

CALCulate<n>:MARKer<m>:FUNCTION:ADEMod:PM[:RESult<t>]:RELative?

<MeasType>

Queries the current *relative* value of the demodulated signal for the specified trace (as displayed in the "Result Summary" in manual operation).

Note that all windows with the same evaluation method have the same traces.

The unit of the results depends on the `CONFigure:ADEMod:RESults:UNIT` setting.**Suffix:**

<n> irrelevant

<m> irrelevant

<t> [Trace](#)**Query parameters:**

<MeasType>

PPEak

Positive peak (+PK)

MPEak | NPEak

Negative peak (-PK)

MIDDLEAverage of positive and negative peaks \pm PK/2**RMS**

Root mean square value

Return values:

<MeasTypeResult>

Example:

CALC:FEED 'XTIM:PM:TDOM'

Switches on the PM time domain result display.

DISP:TRAC ON

Switches on the trace.

CALC:MARK:FUNC:ADEM:PM? PPE

Queries the peak value of the demodulated PM trace.

Usage:

Query only

CALCulate<n>:MARKer<m>:FUNction:ADEMod:CARRier[:RESult<t>]?

Queries the carrier power, which is determined from the Clr/Write data.

Suffix:<n> [Window](#)

<m> irrelevant

<t> [Trace](#)**Return values:**

<CPower> Power of the carrier without modulation in dBm.

Usage:

Query only

CALCulate<n>:MARKer<m>:FUNction:ADEMod:DISTortion[:WRITe]:RESult<t>?

Queries the result of the modulation distortion measurement in the specified window for the specified trace.

Note that this value is only calculated if an AF Spectrum window is displayed.

Suffix:<n> [Window](#)

<m> irrelevant

<t> [Trace](#)**Return values:**

<DISTORT> numeric value
 Modulation distortion in percent.
 Default unit: %

Usage:

Query only

CALCulate<n>:MARKer<m>:FUNction:ADEMod:FERRor[:RESult<t>]?

Queries the carrier offset (= frequency error) for FM and PM demodulation. The carrier offset is determined from the current measurement data (CLR/WRITE). The modulation is removed using low pass filtering.

Suffix:<n> [Window](#)

<m> irrelevant

<t> [Trace](#)**Return values:**

<CarrOffset> The deviation of the calculated carrier frequency to the ideal carrier frequency in Hz.

Usage: Query only**CALCulate<n>:MARKer<m>:FUNction:ADEMod:SINad:RESult<t>?**

Queries the result of the signal-to-noise-and-distortion (SINAD) measurement in the specified window for the specified trace.

Note that this value is only calculated if an AF Spectrum window is displayed.

Suffix:<n> [Window](#)

<m> irrelevant

<t> [Trace](#)**Return values:**

<SINAD> The signal-to-noise-and-distortion ratio in dB.

Usage: Query only**CALCulate<n>:MARKer<m>:FUNction:ADEMod:THD:RESult<t>?**

Queries the result of the total harmonic distortion (THD) measurement in the specified window.

Note that this value is only calculated if an AF Spectrum window is displayed.

Suffix:<n> [Window](#)

<m> irrelevant

<t> [Trace](#)**Return values:**

<THD> Total harmonic distortion of the demodulated signal in dB.

Usage: Query only

10.6.3 Trace export

MMEMory:STORe<n>:TRACe.....	173
FORMat:DEXPort:DSEParator.....	173
FORMat:DEXPort:HEADer.....	174
FORMat:DEXPort:TRACes.....	174

MMEMory:STORe<n>:TRACe <Trace>, <FileName>

Exports trace data from the specified window to an ASCII file.

Secure User Mode

In secure user mode, settings that are stored on the instrument are stored to volatile memory, which is restricted to 256 MB. Thus, a "memory limit reached" error can occur although the hard disk indicates that storage space is still available.

To store data permanently, select an external storage location such as a USB memory device.

For details, see "Protecting Data Using the Secure User Mode" in the "Data Management" section of the R&S ESW base unit user manual.

Suffix:

<n> [Window](#)

Parameters:

<Trace> Number of the trace to be stored
(This parameter is ignored if the option "Export all Traces and all Table Results" is activated in the Export configuration settings, see [FORMat:DEXPort:TRACes](#) on page 174).

<FileName> String containing the path and name of the target file.

Example:

```
MMEM:STOR1:TRAC 1, 'C:\TEST.ASC'
```

Stores trace 1 from window 1 in the file TEST.ASC.

FORMat:DEXPort:DSEParator <Separator>

Selects the decimal separator for data exported in ASCII format.

Parameters:

<Separator> **COMMa**
Uses a comma as decimal separator, e.g. 4,05.

POINT
Uses a point as decimal separator, e.g. 4.05.

*RST: *RST has no effect on the decimal separator.
Default is POINT.

Example:

```
FORM:DEXP:DSEP POIN
```

Sets the decimal point as separator.

FORMat:DEXPort:HEADer <State>

If enabled, additional instrument and measurement settings are included in the header of the export file for result data. If disabled, only the pure result data from the selected traces and tables is exported.

See [Section A.3, "Reference: ASCII file export format"](#), on page 183 for details.

Parameters:

<State> ON | OFF | 0 | 1
*RST: 1

FORMat:DEXPort:TRACes <Selection>

Selects the data to be included in a data export file (see [MMEMory:STORe<n>:TRACe](#) on page 173).

Parameters:

<Selection> SINGle | ALL

SINGle

Only a single trace is selected for export, namely the one specified by the [MMEMory:STORe<n>:TRACe](#) command.

ALL

Selects all active traces and result tables (e.g. "Result Summary", marker peak list etc.) in the current application for export to an ASCII file.

The <trace> parameter for the [MMEMory:STORe<n>:TRACe](#) command is ignored.

*RST: SINGle

10.7 Analysis

The functionality to analyze measurement results is the same as that of the Spectrum application.

For a comprehensive list and description of remote commands, refer to the corresponding topics in the user manual of the R&S ESW.

CALCulate<n>:MARKer<m>:LINK	174
CALCulate<n>:SGRam:LAYout	175
CALCulate<n>:SPECtrogram:LAYout	175
CALCulate<n>:DELTamarker<m>:FUNCTion:AFPHase:RESult?	175
CALCulate<n>:DELTamarker<m>:FUNCTion:AFPHase[:STATe]	175
CALCulate<n>:MARKer<m>:FUNCTion:AFPHase:RESult?	175
CALCulate<n>:MARKer<m>:FUNCTion:AFPHase[:STATe]	175

CALCulate<n>:MARKer<m>:LINK <DisplayType>

Links the specified marker in all displays of the specified type.

Suffix:

<n> irrelevant

<m> [Marker](#)

Parameters:

<DisplayType> TIME | SPECTrum | BOTH | NONE

TIME

Links the markers in all time domain diagrams

SPECTrum

Links the markers in all AF Spectrum displays

BOTH

Links the markers both in the time domain diagrams and in the AF Spectrum displays

NONE

Markers are not linked.

*RST: NONE

Manual operation: See ["Link AF Spectrum Marker"](#) on page 82
See ["Link Time Marker"](#) on page 82

CALCulate<n>:SGRam:LAYout <State>

CALCulate<n>:SPECTrogram:LAYout <State>

CALCulate<n>:DELTaMarker<m>:FUNctIon:AFPHase:RESult?

CALCulate<n>:DELTaMarker<m>:FUNctIon:AFPHase[:STATe] <State>

CALCulate<n>:MARKer<m>:FUNctIon:AFPHase:RESult?

CALCulate<n>:MARKer<m>:FUNctIon:AFPHase[:STATe] <State>

Is only available for AF spectrum result displays. If enabled, the phase value at each marker position is included in the marker table. The function is always enabled for all active markers in the selected display, it cannot be disabled for individual markers.

Suffix:

<n> 1..n
[Window](#)

<m> 1..n
irrelevant

Parameters:

<State> ON | OFF | 0 | 1

OFF | 0

Switches the function off

ON | 1

Switches the function on

*RST: 0

Example: CALC3:MARK:FUNC:AFPH:STAT ON

Manual operation: See ["AF Phase Marker"](#) on page 82

10.8 Data import and export

<code>MMEemory:LOAD:IQ:STATe</code>	176
<code>MMEemory:STORe<n>:IQ:COMMeNt</code>	176
<code>MMEemory:STORe<n>:IQ:STATe</code>	176

`MMEemory:LOAD:IQ:STATe 1, <FileName>`

Restores I/Q data from a file.

Setting parameters:

`<FileName>` string
String containing the path and name of the source file.
The file type is determined by the file extension. If no file extension is provided, the file type is assumed to be `.iq.tar`.
For `.mat` files, Matlab® v4 is assumed.

Example: Loads IQ data from the specified file.

Usage: Setting only

`MMEemory:STORe<n>:IQ:COMMeNt <Comment>`

Adds a comment to a file that contains I/Q data.

Suffix:

`<n>` irrelevant

Parameters:

`<Comment>` String containing the comment.

Example: `MME:STOR:IQ:COMM 'Device test 1b'`
Creates a description for the export file.
`MME:STOR:IQ:STAT 1, 'C:\R_S\Instr\user\data.iq.tar'`
Stores I/Q data and the comment to the specified file.

`MMEemory:STORe<n>:IQ:STATe <1>, <FileName>`

Writes the captured I/Q data to a file.

By default, the contents of the file are in 32-bit floating point format.

Suffix:

`<n>` 1..n

Parameters:

`<1>`

`<FileName>` String containing the path and name of the target file.
The file type is determined by the file extension. If no file extension is provided, the file type is assumed to be `.iq.tar`.
For `.mat` files, Matlab® v4 is assumed.

Example: MMEM:STOR:IQ:STAT 1, 'C:
 \R_S\Instr\user\data.iq.tar'
 Stores the captured I/Q data to the specified file.

Usage: Asynchronous command

10.9 Programming example

In this example we will configure and perform an Analog Modulation Analysis measurement to demonstrate the remote control commands.

Signal generator settings (e.g. R&S SMW):

Frequency:	500 MHz
Level:	-10 dBm
Modulation:	FM
Modulation frequency:	10 kHz
Frequency deviation:	50 kHz

```
//-----Preparing the measurement -----
//Reset the instrument
*RST

//Set the center frequency to 500 MHz
FREQ:CENT 500 MHz
//Set the reference level to 0 dBm
DISP:TRAC:Y:SCAL:RLEV 0

//----- Activating an Analog Modulation Analysis measurement channel -----
//Activate an Analog Modulation Analysis measurement channel named "FMDemodulation"
INST:CRE:NEW ADEM,'FMDemodulation'

//----- Configuring data acquisition -----
//Set the measurement time to 1 ms (=10 periods)
ADEM:MTIM 1ms
//Optimize the scaling of the y-axis for the current measurement (continuously)
SENS:ADJ:SCAL:Y:AUTO ON
//Set the demodulation bandwidth to 400 kHz
BAND:DEM 400 kHz
//Trigger when magnitude of I/Q data reaches -50dBm
TRIG:SOUR IQP
TRIG:LEV:IQP -50

//----- Configuring the result display -----
```

```

//Add an FM Spectrum result display below FM Time Domain
LAY:ADD:WIND? '1',BEL,'XTIM:FM:AFSP'
//Define two traces in the FM Spectrum: 1: Clear/write, 2: average
ADEM:FM:AFSP WRIT,AVER,OFF,OFF,OFF,OFF
//Set analog demodulator to execute 30 sweeps with 32000 samples each
//at a sample rate of 8 MHz; use IQ trigger, trigger on positive slope
//with a pretrigger offset of 500 samples
ADEM:SET 8MHz,32000,IQP,POS,-500,30

//-----Performing the Measurement-----

//Stop continuous sweep
INIT:CONT OFF

//Start a new measurement with 30 sweeps and wait for the end
INIT;*WAI

//-----Retrieving Results-----
//Query the carrier power
CALC:MARK:FUNC:ADEM:CARR?
//Result: -10.37 [dBm]

//Query the signal-to-noise-and-distortion ratio from the FM Spectrum
CALC2:MARK:FUNC:ADEM:SIN:RES?
//Result: 65.026 [dB]

//Query the total harmonic distortion of the demodulated signal
//from the FM Spectrum
CALC2:MARK:FUNC:ADEM:THD:RES?
//Result: -66.413 [dB]

//Query the FM carrier offset (=frequency error) for the most recent
//measurement (trace 1)
CALC:MARK:FUNC:ADEM:FERR?
//Result: 649.07 [Hz]

//Query FM carrier offset averaged over 30 measurements
ADEM:FM:OFFS? AVER
//Result: 600 [Hz]

//Retrieve the trace data of the most recent measurement (trace 1)
TRAC:DATA? TRACE1
//Result: -1.201362252,-1.173495054,-1.187217355,-1.186594367,-1.171583891,
//-1.188250422,-1.204138160,-1.181404829,-1.186317205,-1.197872400, [...]

//Retrieve the averaged trace data for all 30 measurements (trace 2)

```

```
TRAC:DATA? TRACE2//Result: -1.201362252,-1.173495054,-1.187217355,-1.186594367,-1.171583891,  
//-1.188250422,-1.204138160,-1.181404829,-1.186317205,-1.197872400, [...]
```

Annex

A Reference

A.1 Predefined standards and settings

You can configure the Analog Modulation Analysis application using predefined standard settings. This allows for quick and easy configuration for commonly performed measurements.

For details see [Section 5.1, "Configuration according to digital standards"](#), on page 36.

Provided standard files

The instrument comes prepared with the following standard settings:

- AM Broadcast
- FM Narrowband
- FM Broadcast
- Frequency Settling
- None (default settings)

The default storage location for the settings files is:

```
C:\R_S\Instr\User\predefined\AdemodPredefined.
```

Predefined settings

The following parameters can be stored in a standard settings file. Any parameters that are not included in the xml file are set to their default values when the standard is loaded.

Measurement settings:

- DBW
- AQT
- Demod Filter
- Sweep Points
- Squelch (State, Level)
- Units (Phase, THD)
- RF Span

Window display settings:

- Position
- State
- Window number

Predefined standards and settings

- Window type (all evaluation methods supported by the Analog Modulation Analysis application; see [Section 3, "Measurements and result displays"](#), on page 13)
- Scaling (Ref Position, Dev per Division)
- Time Domain Zoom (State, Start, Length)

AF specific settings:

- AF Center
- AF Span
- AF Filters (Lowpass, Highpass, Deemphasis, Weighting)
- Scaling for Spectrum (Ref Value, Deviation)
- Scaling for Time Domain (Ref Value, AF Coupling (FM/PM only))

Table A-1: List of predefined standards and settings

Setting	AM Broadcast	FM Narrowband	FM Broadcast	Frequency Settling *)	None (Default)
Demod. bandwidth	100 kHz	100 kHz	400 kHz	5 MHz	5 MHz
Aquisition time	100 ms	100 ms	100 ms	10 ms	62.5 μ s
Input coupling	AC	AC	AC		AC
Squelch level				-30 dBm	-20 dBm
Windows	"RF Spectrum" "AM Time Domain" "AM Spectrum" "Result Summary"	"RF Spectrum" "FM Time Domain" "FM Spectrum" "Result Summary"	"RF Spectrum" "FM Time Domain" "FM Spectrum" "Result Summary"	"FM Time Domain" "RF Time Domain" "Result Summary"	"FM Time Domain" "Result Summary"
AF filter - High-pass	20 kHz	50 Hz			-
AF filter - Low-pass	15 kHz	3 kHz	150 kHz		-
RF Spectrum					
Span	50 kHz	25 kHz	400 kHz		
AM/FM Time Domain					
Time domain zoom	10 ms	10 ms	10 ms		-
Dev per division		1 kHz	20 kHz	100 kHz	50 kHz
Time domain					
Settling Time State				ON	
AM/FM Spectrum					
Start freq.	0 Hz	0 Hz	0 Hz		
*) The Frequency Settling scenario requires a manually defined trigger					

Formats for returned values: ASCII format and binary format

Setting	AM Broadcast	FM Narrowband	FM Broadcast	Frequency Settling *)	None (Default)
Stop freq.	15 kHz	5 kHz	63.33 kHz		
Ref. value		5 kHz	75 kHz		

*) The Frequency Settling scenario requires a manually defined trigger

A.2 Formats for returned values: ASCII format and binary format

When trace data is retrieved using the `TRAC:DATA` or `TRAC:IQ:DATA` command, the data is returned in the format defined using the `FORMat[:DATA]` on page 166. The possible formats are described here.

- **ASCII Format (FORMat ASCII):**
The data is stored as a list of comma-separated values (CSV) of the measured values in floating point format.
- **Binary Format (FORMat REAL,16/32/64):**
The data is stored as binary data (definite length block data according to IEEE 488.2), each measurement value being formatted in 16-bit/32-bit/64-bit IEEE 754 floating-point-format.
The schema of the result string is as follows:
#<Length of length><Length of data><value1><value2>...<value n>
with:

<Length of length>	Number of digits of the following number of data bytes
<Length of data>	Number of following data bytes
<Value>	2-byte/4-byte/8-byte floating point value

Example: #41024<Data>... contains 1024 data bytes

Data blocks larger than 999,999,999 bytes

According to SCPI, the header of the block data format allows for a maximum of 9 characters to describe the data length. Thus, the maximum REAL 32 data that can be represented is 999,999,999 bytes. However, the R&S ESW is able to send larger data blocks. In this case, the length of the data block is placed in brackets, e.g.

#(1234567890) <value1><value2>...



Reading out data in binary format is quicker than in ASCII format. Thus, binary format is recommended for large amounts of data.

A.3 Reference: ASCII file export format

Trace data can be exported to a file in ASCII format for further evaluation in other applications. This reference describes in detail the format of the export files for result data.

The file consists of the header information (general configuration of the measurement) and the measurement results. Optionally, the header can be excluded from the file.

The data of the file header consist of three columns, each separated by a semicolon: parameter name; numeric value; basic unit. The data section starts with the keyword "Trace <n>" (<n> = number of stored trace). The measured data follows in one or several columns (depending on the measurement), which are also separated by a semicolon.

The results are output in the same order as they are displayed on the screen: window by window, trace by trace, and table row by table row.

Generally, the format of this ASCII file can be processed by spreadsheet calculation programs, e.g. MS Excel. Different language versions of evaluation programs can require a different handling of the decimal point. Thus, you can define the decimal separator to use (decimal point or comma).

A.4 I/Q data file format (iq-tar)

I/Q data is packed in a file with the extension `.iq.tar`. An `iq-tar` file contains I/Q data in binary format together with meta information that describes the nature and the source of data, e.g. the sample rate. The objective of the `iq-tar` file format is to separate I/Q data from the meta information while still having both inside one file. In addition, the file format allows you to include user-specific data and to preview the I/Q data in a web browser (not supported by all web browsers).

The `iq-tar` container packs several files into a single `.tar` archive file. Files in `.tar` format can be unpacked using standard archive tools (see http://en.wikipedia.org/wiki/Comparison_of_file_archivers) available for most operating systems. The advantage of `.tar` files is that the archived files inside the `.tar` file are not changed (not compressed) and thus it is possible to read the I/Q data directly within the archive without the need to unpack (untar) the `.tar` file first.



Sample iq-tar files

Some sample `iq-tar` files are provided in the `C:\R_S\Instr\User/Demo/` directory on the R&S ESW.



An application note on converting Rohde & Schwarz I/Q data files is available from the Rohde & Schwarz website:

[1EF85: Converting R&S I/Q data files](#)

Contained files

An `iq-tar` file must contain the following files:

- **I/Q parameter XML file**, e.g. `xyz.xml`
Contains meta information about the I/Q data (e.g. sample rate). The filename can be defined freely, but there must be only one single I/Q parameter XML file inside an `iq-tar` file.
- **I/Q data binary file**, e.g. `xyz.complex.float32`
Contains the binary I/Q data of all channels. There must be only one single I/Q data binary file inside an `iq-tar` file.

Optionally, an `iq-tar` file can contain the following file:

- **I/Q preview XSLT file**, e.g. `open_IqTar_xml_file_in_web_browser.xslt`
Contains a stylesheet to display the I/Q parameter XML file and a preview of the I/Q data in a web browser (not supported by all web browsers).
A sample stylesheet is available at http://www.rohde-schwarz.com/file/open_IqTar_xml_file_in_web_browser.xslt.

- [I/Q parameter XML file specification](#)..... 184
- [I/Q data binary file](#)..... 189

A.4.1 I/Q parameter XML file specification



The content of the I/Q parameter XML file must comply with the XML schema `RsIqTar.xsd` available at: <http://www.rohde-schwarz.com/file/RsIqTar.xsd>.

In particular, the order of the XML elements must be respected, i.e. `iq-tar` uses an "ordered XML schema". For your own implementation of the `iq-tar` file format make sure to validate your XML file against the given schema.

The following example shows an I/Q parameter XML file. The XML elements and attributes are explained in the following sections.

Sample I/Q parameter XML file: `xyz.xml`

```
<?xml version="1.0" encoding="UTF-8"?>
<?xml-stylesheet type="text/xsl"
href="open_IqTar_xml_file_in_web_browser.xslt"?>
<RS_IQ_TAR_FileFormat fileFormatVersion="1"
xsi:noNamespaceSchemaLocation="RsIqTar.xsd"
xmlns:xsi="http://www.w3.org/2001/XMLSchema-instance">
  <Name>R&S ESW</Name>
  <Comment>Here is a comment</Comment>
  <DateTime>2011-01-24T14:02:49</DateTime>
  <Samples>68751</Samples>
  <Clock unit="Hz">6.5e+006</Clock>
  <Format>complex</Format>
  <DataType>float32</DataType>
  <ScalingFactor unit="V">1</ScalingFactor>
```

```

    <NumberOfChannels>1</NumberOfChannels>
<DataFilename>xyz.complex.float32</DataFilename>
<UserData>
  <UserDefinedElement>Example</UserDefinedElement>
</UserData>
  <PreviewData>...</PreviewData>
</RS_IQ_TAR_FileFormat>

```

A.4.1.1 Minimum data elements

The following data elements are the minimum required for a valid `iq-tar` file. They are always provided by an `iq-tar` file export from a Rohde & Schwarz product. If not specified otherwise, it must be available in all `iq-tar` files used to import data to a Rohde & Schwarz product.

Element	Possible Values	Description
<RS_IQ_TAR_FileFormat>	-	The root element of the XML file. It must contain the attribute <code>fileFormatVersion</code> that contains the number of the file format definition.
<Name>	string	Optional: describes the device or application that created the file.
<Comment>	string	Optional: contains text that further describes the contents of the file.
<DateTime>	yyyy-mm-ddThh:mm:ss	Contains the date and time of the creation of the file. Its type is <code>xs:dateTime</code> (see <code>RsIqTar.xsd</code>).
<Samples>	integer	Contains the number of samples of the I/Q data. For multi-channel signals all channels have the same number of samples. One sample can be: <ul style="list-style-type: none"> • A complex number represented as a pair of I and Q values • A complex number represented as a pair of magnitude and phase values • A real number represented as a single real value See also <Format> element.
<Clock>	double	Contains the clock frequency in Hz, i.e. the sample rate of the I/Q data. A signal generator typically outputs the I/Q data at a rate that equals the clock frequency. If the I/Q data was captured with a signal analyzer, the signal analyzer used the clock frequency as the sample rate. The attribute <code>unit</code> must be set to "Hz".
<Format>	complex real polar	Specifies how the binary data is saved in the I/Q data binary file (see <DataFilename> element). Every sample must be in the same format. The format can be one of the following: <ul style="list-style-type: none"> • <code>complex</code>: Complex number in cartesian format, i.e. I and Q values interleaved. I and Q are unitless • <code>real</code>: Real number (unitless) • <code>polar</code>: Complex number in polar format, i.e. magnitude (unitless) and phase (rad) values interleaved. Requires <code>DataType = float32 or float64</code>

I/Q data file format (iq-tar)

Element	Possible Values	Description
<DataType>	int8 int16 int32 float32 float64	Specifies the binary format used for samples in the I/Q data binary file (see <DataFilename> element and Section A.4.2, "I/Q data binary file" , on page 189). The following data types are allowed: <ul style="list-style-type: none"> • int8: 8 bit signed integer data • int16: 16 bit signed integer data • int32: 32 bit signed integer data • float32: 32 bit floating point data (IEEE 754) • float64: 64 bit floating point data (IEEE 754)
<ScalingFactor>	double	Optional: describes how the binary data can be transformed into values in the unit Volt. The binary I/Q data itself has no unit. To get an I/Q sample in the unit Volt the saved samples have to be multiplied by the value of the <ScalingFactor>. For polar data only the magnitude value has to be multiplied. For multi-channel signals the <ScalingFactor> must be applied to all channels. The attribute unit must be set to "v". The <ScalingFactor> must be > 0. If the <ScalingFactor> element is not defined, a value of 1 V is assumed.
<NumberOfChannels>	integer	Optional: specifies the number of channels, e.g. of a MIMO signal, contained in the I/Q data binary file. For multi-channels, the I/Q samples of the channels are expected to be interleaved within the I/Q data file (see Section A.4.2, "I/Q data binary file" , on page 189). If the <NumberOfChannels> element is not defined, one channel is assumed.
<DataFilename>		Contains the filename of the I/Q data binary file that is part of the iq-tar file. It is recommended that the filename uses the following convention: <xyz>.<Format>.<Channels>ch.<Type> <ul style="list-style-type: none"> • <xyz> = a valid Windows file name • <Format> = complex, polar or real (see Format element) • <Channels> = Number of channels (see NumberOfChannels element) • <Type> = float32, float64, int8, int16, int32 or int64 (see DataType element) Examples: <ul style="list-style-type: none"> • xyz.complex.1ch.float32 • xyz.polar.1ch.float64 • xyz.real.1ch.int16 • xyz.complex.16ch.int8
<UserData>	xml	Optional: contains user, application or device-specific XML data which is not part of the iq-tar specification. This element can be used to store additional information, e.g. the hardware configuration. User data must be valid XML content.
<PreviewData>	xml	Optional: contains further XML elements that provide a preview of the I/Q data. The preview data is determined by the routine that saves an iq-tar file (e.g. R&S ESW). For the definition of this element refer to the RsIqTar.xsd schema. Note that the preview can be only displayed by current web browsers that have JavaScript enabled and if the XSLT stylesheet open_IqTar_xml_file_in_web_browser.xslt is available.

A.4.1.2 Example

The following example demonstrates the XML description inside the `iq-tar` file. Note that this preview is not supported by all web browsers.

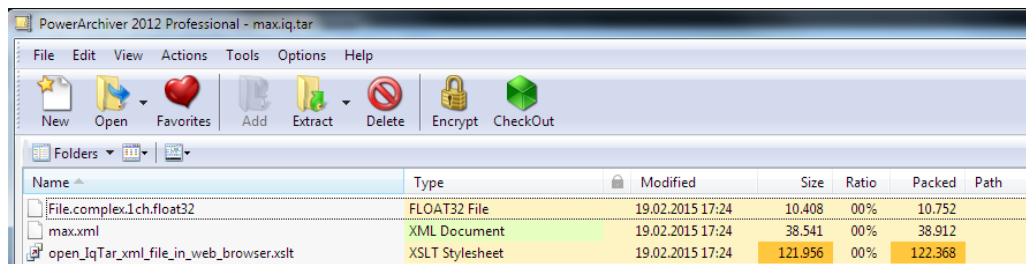

Name	Type	Modified	Size	Ratio	Packed	Path
File.complex1ch.float32	FLOAT32 File	19.02.2015 17:24	10.408	00%	10.752	
max.xml	XML Document	19.02.2015 17:24	38.541	00%	38.912	
open_IqTar_xml_file_in_web_browser.xslt	XSLT Stylesheet	19.02.2015 17:24	121.956	00%	122.368	

Open the `xml` file in a web browser. If the stylesheet `open_IqTar_xml_file_in_web_browser.xslt` is in the same directory, the web browser displays the `xml` file in a readable format.

max.xml (of .iq.tar file)

Description	
Saved by	VSE_1.10
Date & Time	2014-11-24 14:34:06
Sample rate	32 MHz
Number of samples	3200300
Duration of signal	100.009 ms
Data format	complex, float32
Data filename	File.complex.1ch.float32
Scaling factor	1 V

IQ Analyzer

Power vs time
y-axis: 10 dB /div
x-axis: 10 ms /div

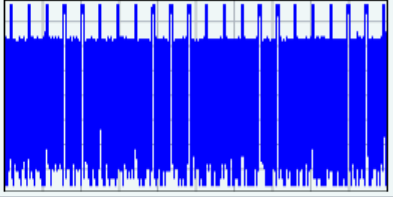

Spectrum
y-axis: 10 dB /div
x-axis: 5 MHz /div

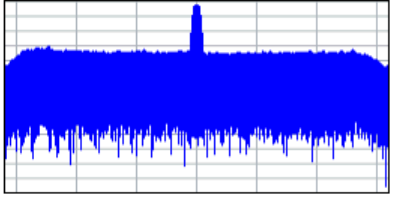

I/Q

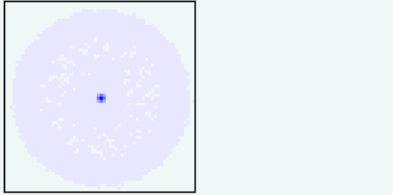

```
<?xml version="1.0" encoding="UTF-8"?>
<?xml-stylesheet type="text/xsl" href="open_IqTar_xml_file_in_web_browser.xslt"?>
<RS_IQ_TAR_FileFormat fileFormatVersion="1" xsi:noNamespaceSchemaLocation=
"http://www.rohde-schwarz.com/file/RsIqTar.xsd" xmlns:xsi=
"http://www.w3.org/2001/XMLSchema-instance">
  <Name>VSE_1.10a 29 Beta</Name>
  <Comment></Comment>
  <DateTime>2015-02-19T15:24:58</DateTime>
  <Samples>1301</Samples>
  <Clock unit="Hz">32000000</Clock>
  <Format>complex</Format>
  <DataType>float32</DataType>
```

```

<ScalingFactor unit="V">1</ScalingFactor>
<NumberOfChannels>1</NumberOfChannels>
<DataFilename>File.complex.1ch.float32</DataFilename>

<UserData>
  <RohdeSchwarz>
    <DataImportExport_MandatoryData>
      <ChannelNames>
        <ChannelName>IQ Analyzer</ChannelName>
      </ChannelNames>
      <CenterFrequency unit="Hz">0</CenterFrequency>
    </DataImportExport_MandatoryData>
    <DataImportExport_OptionalData>
      <Key name="Ch1_NumberOfPostSamples">150</Key>
      <Key name="Ch1_NumberOfPreSamples">150</Key>
    </DataImportExport_OptionalData>
  </RohdeSchwarz>
</UserData>

</RS_IQ_TAR_FileFormat>

```

Example: ScalingFactor

Data stored as int16 and a desired full scale voltage of 1 V

ScalingFactor = 1 V / maximum int16 value = 1 V / 2^{15} = 3.0517578125e-5 V

Scaling Factor	Numerical value	Numerical value x ScalingFactor
Minimum (negative) int16 value	$-2^{15} = -32768$	-1 V
Maximum (positive) int16 value	$2^{15}-1 = 32767$	0.999969482421875 V

A.4.2 I/Q data binary file

The I/Q data is saved in binary format according to the format and data type specified in the XML file (see <Format> element and <DataType> element). To allow reading and writing of streamed I/Q data, all data is interleaved, i.e. complex values are interleaved pairs of I and Q values and multi-channel signals contain interleaved (complex) samples for channel 0, channel 1, channel 2 etc. If the <NumberOfChannels> element is not defined, one channel is presumed.

Example: Element order for real data (1 channel)

```

I[0],           // Real sample 0
I[1],           // Real sample 1
I[2],           // Real sample 2
...

```

Example: Element order for complex cartesian data (1 channel)

```
I[0], Q[0],           // Real and imaginary part of complex sample 0
I[1], Q[1],           // Real and imaginary part of complex sample 1
I[2], Q[2],           // Real and imaginary part of complex sample 2
...
```

Example: Element order for complex polar data (1 channel)

```
Mag[0], Phi[0],      // Magnitude and phase part of complex sample 0
Mag[1], Phi[1],      // Magnitude and phase part of complex sample 1
Mag[2], Phi[2],      // Magnitude and phase part of complex sample 2
...
```

Example: Element order for complex cartesian data (3 channels)

Complex data: I[channel no][time index], Q[channel no][time index]

```
I[0][0], Q[0][0],      // Channel 0, Complex sample 0
I[1][0], Q[1][0],      // Channel 1, Complex sample 0
I[2][0], Q[2][0],      // Channel 2, Complex sample 0

I[0][1], Q[0][1],      // Channel 0, Complex sample 1
I[1][1], Q[1][1],      // Channel 1, Complex sample 1
I[2][1], Q[2][1],      // Channel 2, Complex sample 1

I[0][2], Q[0][2],      // Channel 0, Complex sample 2
I[1][2], Q[1][2],      // Channel 1, Complex sample 2
I[2][2], Q[2][2],      // Channel 2, Complex sample 2
...
```

Example: Element order for complex cartesian data (1 channel)

This example demonstrates how to store complex cartesian data in float32 format using MATLAB®.

```
% Save vector of complex cartesian I/Q data, i.e. iqiqiq...
N = 100
iq = randn(1,N)+1j*randn(1,N)
fid = fopen('xyz.complex.float32','w');
for k=1:length(iq)
    fwrite(fid, single(real(iq(k))), 'float32');
    fwrite(fid, single(imag(iq(k))), 'float32');
end
fclose(fid)
```

Example: PreviewData in XML

```
<PreviewData>
  <ArrayOfChannel length="1">
    <Channel>
      <PowerVsTime>
        <Min>
```

```

        <ArrayOfFloat length="256">
            <float>-134</float>
            <float>-142</float>
            ...
            <float>-140</float>
        </ArrayOfFloat>
    </Min>
    <Max>
        <ArrayOfFloat length="256">
            <float>-70</float>
            <float>-71</float>
            ...
            <float>-69</float>
        </ArrayOfFloat>
    </Max>
</PowerVsTime>
<Spectrum>
    <Min>
        <ArrayOfFloat length="256">
            <float>-133</float>
            <float>-111</float>
            ...
            <float>-111</float>
        </ArrayOfFloat>
    </Min>
    <Max>
        <ArrayOfFloat length="256">
            <float>-67</float>
            <float>-69</float>
            ...
            <float>-70</float>
            <float>-69</float>
        </ArrayOfFloat>
    </Max>
</Spectrum>
<IQ>
    <Histogram width="64" height="64">0123456789...0</Histogram>
</IQ>
</Channel>
</ArrayOfChannel>
</PreviewData>

```

List of commands

[SENSe:]ADEMod:AF:CENTer.....	142
[SENSe:]ADEMod:AF:SPAN.....	142
[SENSe:]ADEMod:AF:SPAN:FULL.....	142
[SENSe:]ADEMod:AF:STARt.....	143
[SENSe:]ADEMod:AF:STOP.....	143
[SENSe:]ADEMod:AM:RELative:AFSPectrum:RESult?.....	165
[SENSe:]ADEMod:AM:RELative:AFSPectrum[:TYPE]?.....	163
[SENSe:]ADEMod:AM:RELative[:TDOMain]:RESult?.....	164
[SENSe:]ADEMod:AM:RELative[:TDOMain][:TYPE]?.....	163
[SENSe:]ADEMod:AM[:ABSolute][:TDOMain]:RESult?.....	164
[SENSe:]ADEMod:AM[:ABSolute][:TDOMain][:TYPE]?.....	163
[SENSe:]ADEMod:FM:AFSPectrum:RESult?.....	165
[SENSe:]ADEMod:FM:AFSPectrum[:TYPE]?.....	163
[SENSe:]ADEMod:FM[:TDOMain]:RESult?.....	165
[SENSe:]ADEMod:FM[:TDOMain][:TYPE]?.....	163
[SENSe:]ADEMod:MTIME.....	131
[SENSe:]ADEMod:PM:AFSPectrum:RESult?.....	165
[SENSe:]ADEMod:PM:AFSPectrum[:TYPE]?.....	163
[SENSe:]ADEMod:PM:RPOint[:X].....	136
[SENSe:]ADEMod:PM:RPOint[:X]:MODE.....	137
[SENSe:]ADEMod:PM[:TDOMain]:RESult?.....	165
[SENSe:]ADEMod:PM[:TDOMain][:TYPE]?.....	163
[SENSe:]ADEMod:PRESet:RESTore.....	102
[SENSe:]ADEMod:PRESet:STORe.....	102
[SENSe:]ADEMod:PRESet[:STANdard].....	101
[SENSe:]ADEMod:RLENgth.....	131
[SENSe:]ADEMod:SET.....	131
[SENSe:]ADEMod:SPECTrum:BWIDth[:RESolution].....	132
[SENSe:]ADEMod:SPECTrum:RESult?.....	165
[SENSe:]ADEMod:SPECTrum:SPAN:ZOOM.....	143
[SENSe:]ADEMod:SPECTrum:SPAN[:MAXimum].....	144
[SENSe:]ADEMod:SPECTrum[:TYPE].....	163
[SENSe:]ADEMod:SQUelch:LEVel.....	137
[SENSe:]ADEMod:SQUelch[:STATe].....	137
[SENSe:]ADEMod:SRATe.....	133
[SENSe:]ADEMod<n>:AF:COUPling.....	136
[SENSe:]ADEMod<n>:ZOOM:LENgth.....	138
[SENSe:]ADEMod<n>:ZOOM:LENgth:MODE.....	139
[SENSe:]ADEMod<n>:ZOOM:STARt.....	139
[SENSe:]ADEMod<n>:ZOOM[:STATe].....	140
[SENSe:]ADJust:ALL.....	125
[SENSe:]ADJust:CONFigure:HYSTEResis:LOWer.....	126
[SENSe:]ADJust:CONFigure:HYSTEResis:UPPer.....	126
[SENSe:]ADJust:CONFigure:LEVel:DURation.....	125
[SENSe:]ADJust:CONFigure:LEVel:DURation:MODE.....	125
[SENSe:]ADJust:CONFigure:TRIGger.....	127
[SENSe:]ADJust:FREQUency.....	127

[SENSe:]ADJust:LEVel.....	116
[SENSe:]ADJust:SCALe[:Y]:AUTO[:CONTInuous].....	127
[SENSe:]AVERAge<n>:COUNT.....	133
[SENSe:]BANDwidth[:RESolution].....	134
[SENSe:]BWIDth:DEMod.....	133
[SENSe:]BWIDth:DEMod:TYPE.....	133
[SENSe:]DEMod:SQUelch:LEVel.....	108
[SENSe:]DEMod:SQUelch[:STATe].....	109
[SENSe:]FILTer<n>:AOFF.....	145
[SENSe:]FILTer<n>:AWEighted[:STATe].....	144
[SENSe:]FILTer<n>:CCIR:WEIGhted[:STATe].....	145
[SENSe:]FILTer<n>:CCIR[:UNWeighted][:STATe].....	145
[SENSe:]FILTer<n>:CCITt[:STATe].....	146
[SENSe:]FILTer<n>:DEMPHasis:TCONstant.....	146
[SENSe:]FILTer<n>:DEMPHasis[:STATe].....	146
[SENSe:]FILTer<n>:HPASs:FREQuency:MANual.....	147
[SENSe:]FILTer<n>:HPASs:FREQuency[:ABSolute].....	147
[SENSe:]FILTer<n>:HPASs[:STATe].....	148
[SENSe:]FILTer<n>:LPASs:FREQuency:MANual.....	148
[SENSe:]FILTer<n>:LPASs:FREQuency:RELative.....	149
[SENSe:]FILTer<n>:LPASs:FREQuency[:ABSolute].....	148
[SENSe:]FILTer<n>:LPASs[:STATe].....	149
[SENSe:]FREQuency:CENTer.....	116
[SENSe:]FREQuency:CENTer:STEP.....	117
[SENSe:]FREQuency:CENTer:STEP:LINK.....	117
[SENSe:]FREQuency:CENTer:STEP:LINK:FACTor.....	118
[SENSe:]SWEep:COUNT.....	134
[SENSe:]SWEep[:WINDow<n>]:POINTs.....	135
ABORT.....	128
CALCulate<n>:DELTaMarker<m>:FUNCTion:AFPHase:RESult?.....	175
CALCulate<n>:DELTaMarker<m>:FUNCTion:AFPHase[:STATe].....	175
CALCulate<n>:DELTaMarker<m>:X.....	167
CALCulate<n>:DELTaMarker<m>:Y?.....	167
CALCulate<n>:FORMat.....	138
CALCulate<n>:MARKer<m>:FUNCTion:ADEMod:AFREquency[:RESult<t>]?.....	169
CALCulate<n>:MARKer<m>:FUNCTion:ADEMod:AM[:RESult<t>]:RELative?.....	170
CALCulate<n>:MARKer<m>:FUNCTion:ADEMod:AM[:RESult<t>]?.....	169
CALCulate<n>:MARKer<m>:FUNCTion:ADEMod:CARRier[:RESult<t>]?.....	171
CALCulate<n>:MARKer<m>:FUNCTion:ADEMod:DISToRtion[:WRITe]:RESult<t>?.....	171
CALCulate<n>:MARKer<m>:FUNCTion:ADEMod:FERRor[:RESult<t>]?.....	171
CALCulate<n>:MARKer<m>:FUNCTion:ADEMod:FM[:RESult<t>]:RELative?.....	170
CALCulate<n>:MARKer<m>:FUNCTion:ADEMod:FM[:RESult<t>]?.....	169
CALCulate<n>:MARKer<m>:FUNCTion:ADEMod:PM[:RESult<t>]:RELative?.....	170
CALCulate<n>:MARKer<m>:FUNCTion:ADEMod:PM[:RESult<t>]?.....	169
CALCulate<n>:MARKer<m>:FUNCTion:ADEMod:SINad:RESult<t>?.....	172
CALCulate<n>:MARKer<m>:FUNCTion:ADEMod:THD:RESult<t>?.....	172
CALCulate<n>:MARKer<m>:FUNCTion:AFPHase:RESult?.....	175
CALCulate<n>:MARKer<m>:FUNCTion:AFPHase[:STATe].....	175
CALCulate<n>:MARKer<m>:LINK.....	174
CALCulate<n>:MARKer<m>:X.....	168

CALCulate<n>:MARKer<m>:Y?	168
CALCulate<n>:SGRam:LAYout	175
CALCulate<n>:SPECTrogram:LAYout	175
CALCulate<n>:UNIT:POWer	113
CONFigure:ADEMod:RESults:AM:DETEctor<det>:MODE	154
CONFigure:ADEMod:RESults:AM:DETEctor<det>:REFerence	153
CONFigure:ADEMod:RESults:AM:DETEctor<det>:REFerence:MEASStoref<t>	154
CONFigure:ADEMod:RESults:AM:DETEctor<det>:STATe	153
CONFigure:ADEMod:RESults:FM:DETEctor<det>:MODE	154
CONFigure:ADEMod:RESults:FM:DETEctor<det>:REFerence	153
CONFigure:ADEMod:RESults:FM:DETEctor<det>:REFerence:MEASStoref<t>	154
CONFigure:ADEMod:RESults:FM:DETEctor<det>:STATe	153
CONFigure:ADEMod:RESults:PM:DETEctor<det>:MODE	154
CONFigure:ADEMod:RESults:PM:DETEctor<det>:REFerence	153
CONFigure:ADEMod:RESults:PM:DETEctor<det>:REFerence:MEASStoref<t>	154
CONFigure:ADEMod:RESults:PM:DETEctor<det>:STATe	153
CONFigure:ADEMod:RESults:UNIT	155
DISPlay:FORMat	156
DISPlay[:WINDow<n>]:SIZE	156
DISPlay[:WINDow<n>][:SUBWIndow<w>]:TRACe<t>:Y:SPACing	141
DISPlay[:WINDow<n>][:SUBWIndow<w>]:TRACe<t>:Y[:SCALe]	151
DISPlay[:WINDow<n>][:SUBWIndow<w>]:TRACe<t>:Y[:SCALe]:AUTO ONCE	151
DISPlay[:WINDow<n>][:SUBWIndow<w>]:TRACe<t>:Y[:SCALe]:MODE	151
DISPlay[:WINDow<n>][:SUBWIndow<w>]:TRACe<t>:Y[:SCALe]:PDIVision	140
DISPlay[:WINDow<n>][:SUBWIndow<w>]:TRACe<t>:Y[:SCALe]:RLEVel	113
DISPlay[:WINDow<n>][:SUBWIndow<w>]:TRACe<t>:Y[:SCALe]:RLEVel:OFFSet	114
DISPlay[:WINDow<n>][:SUBWIndow<w>]:TRACe<t>:Y[:SCALe]:RPOStion	141
DISPlay[:WINDow<n>][:SUBWIndow<w>]:TRACe<t>:Y[:SCALe]:RVALue	150
FORMat:DEXPort:DSEParator	173
FORMat:DEXPort:HEADer	174
FORMat:DEXPort:TRACes	174
FORMat[:DATA]	166
INITiate:SEQuencer:ABORt	130
INITiate:SEQuencer:IMMediate	130
INITiate:SEQuencer:MODE	130
INITiate<mt>[:IMMediate]	130
INITiate<n>:CONMeas	129
INITiate<n>:CONTInuous	129
INPut:ATTenuation:AUTO	114
INPut:ATTenuation:LIMiter[:STATe]	102
INPut:ATTenuation:PROTEction:RESet	103
INPut:ATTenuation:PROTEction[:STATe]	115
INPut:ATTenuation[:VALue]	115
INPut:COUPLing	103
INPut:GAIN:AUTO	115
INPut:GAIN:LNA:AUTO	115
INPut:GAIN:LNA:STATe	116
INPut:GAIN:STATe	116
INPut:IMPedance	103
INPut:TYPE	103

INSTrument:CREate:DUPLicate.....	98
INSTrument:CREate:REPLace.....	98
INSTrument:CREate[:NEW].....	98
INSTrument:DELeTe.....	99
INSTrument:LIST?.....	99
INSTrument:REName.....	100
INSTrument[:SELeCt].....	100
LAYout:ADD[:WINDow]?.....	157
LAYout:CATalog[:WINDow]?.....	158
LAYout:IDENtify[:WINDow]?.....	158
LAYout:REMOve[:WINDow].....	159
LAYout:REPLace[:WINDow].....	159
LAYout:SPLitter.....	159
LAYout:WINDow<n>:ADD?.....	161
LAYout:WINDow<n>:IDENtify?.....	161
LAYout:WINDow<n>:REMOve.....	162
LAYout:WINDow<n>:REPLace.....	162
MMEMory:LOAD:IQ:STATe.....	176
MMEMory:STORe<n>:IQ:COMMeNt.....	176
MMEMory:STORe<n>:IQ:STATe.....	176
MMEMory:STORe<n>:TRACe.....	173
OUTPut:ADEMod[:ONLine]:SOURce.....	108
OUTPut:TRIGger<tp>:DIReCtion.....	111
OUTPut:TRIGger<tp>:LEVel.....	111
OUTPut:TRIGger<tp>:OTYPe.....	111
OUTPut:TRIGger<tp>:PULSe:IMMeDiate.....	112
OUTPut:TRIGger<tp>:PULSe:LENGth.....	112
OUTPut<ou>:IF:AUDio.....	105
OUTPut<ou>:IF:COUPLing.....	105
OUTPut<ou>:IF:IFFRequency.....	105
OUTPut<ou>:IF:LPASs:FREQuency:MANual.....	106
OUTPut<ou>:IF:LPASs[:STATe].....	106
OUTPut<ou>:IF:SCALe[:VALue].....	107
OUTPut<ou>:IF[:SOURce].....	107
OUTPut<ou>:LINK.....	108
OUTPut<ou>:PROBe<pb>[:POWer].....	110
SYSTem:PRESet:CHANnel[:EXEC].....	101
SYSTem:SEQuencer.....	135
SYSTem:SPEaker:MAXVolumE.....	109
SYSTem:SPEaker:MUTE.....	110
SYSTem:SPEaker:VOLume.....	110
TRACe<n>[:DATA].....	167
TRIGger[:SEQuence]:DTIME.....	120
TRIGger[:SEQuence]:HOLDoff[:TIME].....	120
TRIGger[:SEQuence]:IFPower:HOLDoff.....	120
TRIGger[:SEQuence]:IFPower:HYSTerEsis.....	121
TRIGger[:SEQuence]:LEVel:AM:RELative.....	122
TRIGger[:SEQuence]:LEVel:AM[:ABSolute].....	121
TRIGger[:SEQuence]:LEVel:FM.....	122
TRIGger[:SEQuence]:LEVel:IFPower.....	122

TRIGger[:SEQuence]:LEVel:IQPower.....	123
TRIGger[:SEQuence]:LEVel:PM.....	123
TRIGger[:SEQuence]:LEVel:RFPower.....	123
TRIGger[:SEQuence]:LEVel[:EXTernal].....	122
TRIGger[:SEQuence]:SLOPe.....	124
TRIGger[:SEQuence]:SOURce.....	119
TRIGger[:SEQuence]:TIME:RINTerval.....	124
UNIT<n>:ANGLE.....	152
UNIT<n>:THD.....	152

Index

A

A weighted filter
 AF filters 69

Aborting
 Sweep 61

AC/DC coupling 26, 40, 64, 72

AF 13

AF Auto Scale
 Y-axis 73, 80

AF center
 Demodulation spectrum 66

AF CF 12

AF coupling 64, 72

AF filters 27
 A weighted 69
 CCIR 69
 CCITT 69
 Configuration 68
 Deactivating 71
 Deemphasis 70
 High pass 68
 Low pass 69
 Weighting 69

AF full span
 Demodulation spectrum 66

AF span
 Demodulation spectrum 66
 Displayed 12
 Remote control 142

AF spectrum 65

AF start
 Demodulation spectrum 66

AF stop
 Demodulation spectrum 66

AF trigger 27, 29

AM (Offline)
 Softkey 55

AM Spectrum
 Evaluation method 16

AM Time Domain
 Evaluation method 13

Amplitude
 Scaling 74
 Settings 49

Analog Modulation Analysis
 Measurement examples 86

Analysis
 Settings 81

Application cards 7

Application notes 7

AQT
 see Measurement time 11

ASCII trace export 183

Attenuation 51
 Displayed 11
 Protective (remote) 103

Audio frequency
 see AF 13

Auto adjustment
 Triggered measurement 127

Auto all 78

Auto frequency 78

Auto level
 Hysteresis 79, 80
 Reference level 50, 79
 Softkey 50, 79

Auto scaling 73, 74, 80

Auto settings 78
 Meastime Auto 79
 Meastime Manual 79

Average count 62

B

Bandwidth settings 59

Brochures 7

C

Carrier
 Offset 22, 26
 Power 22

CCIR filter
 AF filters 69

CCITT filter
 AF filters 69

Center frequency 52, 67
 Automatic configuration 78
 Displayed 11, 12
 Softkey 52, 67
 Step size 52

Channel
 Creating (remote) 98, 100
 Deleting (remote) 99
 Duplicating (remote) 98
 Querying (remote) 99
 Renaming (remote) 100
 Replacing (remote) 98
 Selecting (remote) 100

Closing
 Channels (remote) 99
 Windows (remote) 162

Conditions
 Measurement 24

Continue single sweep
 Softkey 61

Continuous sweep
 Softkey 61

Conventions
 SCPI commands 92

Copying
 Channel (remote) 98

D

Data format
 ASCII 182
 Binary 182
 Remote 174

Data sheets 7

DB per division
 Scaling 71

DBW
 see Demodulation bandwidth 11

- Deemphasis filter
 - AF filters 70
 - Remote control 146
 - Deleting
 - Settings files 37
 - Standards 37
 - Demodulation
 - AF spectrum 65
 - Configuration 63
 - Display 78
 - Filter types 27, 60
 - Process 24
 - Relative (remote control) 154
 - Relative (remote) 153
 - RF spectrum 67
 - Scaling 68, 71
 - Settings 62, 63
 - Spectrum 65
 - Spectrum (Result Summary) 67
 - Squelch 45
 - Units 75
 - Demodulation bandwidth 59, 68
 - Conditions 26
 - Deemphasis filter 70
 - Displayed 11
 - Maximum 27
 - Remote control 133
 - Troubleshooting 91
 - Detectors
 - Relative demodulation 154
 - Relative demodulation (remote) 153
 - Remote control 153
 - Dev per division
 - Scaling 71
 - Deviation
 - Scaling 73
 - Diagram footer information 12
 - Digital standards
 - Configuration 36
 - Display configuration
 - Softkey 78
 - Drop-out time
 - Trigger 57
 - Duplicating
 - Channel (remote) 98
- E**
- ENV216 (LISN) 46
 - ENV4200 (LISN) 46
 - Errors
 - IF OVLD 49
 - ESH2-Z5 (LISN) 46
 - ESH3-Z5 (LISN) 46
 - Evaluation
 - Data basis 13
 - Methods 13
 - Evaluation methods
 - Remote 157
 - Examples
 - Remote control 177
 - Export format
 - Traces 183
 - Exporting
 - I/Q data 183, 189
 - Trace data 85
 - External trigger 54
 - EZ-27 (LISN adapter) 46
- F**
- File format
 - Export Files 183
 - Trace export 183
 - filename
 - Settings 37
 - Files
 - Format, I/Q data 183
 - I/Q data binary XML 189
 - I/Q parameter XML 184
 - Filters
 - A weighted (AF) 69
 - AF 68
 - CCIR (AF) 69
 - CCITT (AF) 69
 - Demodulation 26, 27, 60
 - High pass (AF) 68
 - Low pass (AF) 69
 - Weighting (AF) 69
 - FM (Offline)
 - Softkey 55
 - FM Spectrum
 - Evaluation method 17
 - FM Time Domain
 - Evaluation method 14
 - Format
 - Data 182
 - Data (remote) 174
 - see also File format 183
 - Free Run
 - Trigger 54
 - Frequency
 - Configuration 65
 - Deemphasis filter 70
 - Deviation 26
 - Deviation, scaling 71
 - Settings 52
 - Span 67
 - Frontend settings 39
- G**
- Gain level 51
 - Getting started 6
- H**
- Hardware settings
 - Displayed 11
 - High pass filter
 - AF filters 68
 - Hysteresis
 - Lower (Auto level) 80
 - Trigger 56
 - Upper (Auto level) 79
- I**
- I/Q data
 - Export file binary data description 189
 - Export file parameter description 184
 - I/Q Power
 - Trigger 54
 - Trigger level (remote) 123

IF Power	
Trigger	55
Trigger level (remote)	122
Impedance	
Setting	41
Importing	
I/Q data	184
Input	40
Coupling	40
Overload (remote)	103
Settings	39
Signal, parameters	31
Input sources	39
Installation	9
Instrument security procedures	7
iq-tar	
Example file	187
Mandatory data elements	185
K	
Keys	
RUN CONT	61
RUN SINGLE	61
L	
Linking	
Markers	82
LISN	46
Loading	
Settings files	37
Low pass filter	
AF filters	69
Lower Level Hysteresis	80
M	
Marker table	
Evaluation method	23
Markers	
Linked in AF spectrum display	82
Linked in time domain	82
Table (evaluation method)	23
Maximizing	
Windows (remote)	156
Measurement examples	
Analog Modulation Analysis	86
Measurement time	60, 62
Auto settings	79
Displayed	11
Effects	28
Value range	27
Minimum attenuation	51
Modulation	
Depth	22
Depth, scaling	71
Frequency	22, 26
Multiple	
Channels	10
O	
Offset	
Reference level	50
Output	
Analog Modulation Analysis (remote)	108
Configuration (softkey)	42
Parameters	31
Probe power	46
Settings	42
Trigger	46, 47, 57
Overload	
RF input (remote)	103
Overview	
Softkey	38
P	
Parameters	
Input signal	31
Output	31
Peak list	
Evaluation method	23
Performance	
Improving	28
Performing	
AM/FM/PM Modulation Analysis	84
Phase	
Deviation	26
Deviation, scaling	71
Unit	75
Phase Wrap	
Activating	65
PM (Offline)	
Softkey	55
PM Spectrum	
Evaluation method	18
PM Time Domain	
Evaluation method	15
Preamplifier	51
Presetting	
Channels	38
Pretrigger	56
Probe power supply	46
Protection	
RF input (remote)	103
R	
Range	74
Scaling	74
RBW	60
Displayed	11
Remote control	132
Reference level	49
Auto level	50, 79
Displayed	11
Offset	50
Offset, displayed	11
Position	74
Unit	49, 50
Value	49
Reference value	72
Position	72
Release notes	7
Remote commands	
Basics on syntax	92
Boolean values	96
Capitalization	93
Character data	96
Data blocks	96

- Numeric values 95
- Optional keywords 94
- Parameters 94
- Strings 96
- Suffixes 93
- Repetition interval 55
- Res BW
 - see RBW 60
- Resetting
 - RF input protection 103
- Residual FM 26
- Resolution bandwidth
 - see RBW 60
- Restoring
 - Channel settings 38
 - Standard files 38
- Result Display 10
- Result displays
 - Marker table 23
 - Peak list 23
- Result Summary
 - Demodulation spectrum 67
 - Evaluation method 21
 - Retrieving values (remote) 169
- Results 13
 - Analyzing 81
 - Data format (remote) 174
 - Stability 28
- RF (Offline)
 - Softkey 55
- RF attenuation 51
- RF full span 68
- RF input
 - Overload protection (remote) 103
- RF Power
 - Trigger 55
 - Trigger level (remote) 123
- RF Spectrum
 - Evaluation method 20
 - Troubleshooting 91
- RF Time Domain
 - Evaluation method 19
- RUN CONT
 - Key 61
- RUN SINGLE
 - Key 61
- S**
- Safety instructions 7
- Sample rate 27
- Samples
 - Performance 28
- Saving
 - Settings 37
- Scaling
 - AF 71
 - Amplitude range, automatically 74
 - Automatic 73, 80
 - Configuration 71
 - Result Summary 73
 - RF 73
 - Y-axis 74
 - Y-axis (remote control) 141
- Screen layout 10
- Secure user mode
 - Storage location 37
- Security procedures 7
- Sequencer 10
 - Activating (remote) 130
 - Remote 129
- Sequences
 - Aborting (remote) 130
 - Mode (remote) 130
- Service manual 6
- Settings
 - Displayed 38
 - filename 37
 - Restoring files 38
 - Storage location 37
- Settings files
 - Deleting 37
 - Loading 37
 - Predefined 180
 - Saving 37
- Signal-to-noise ratio 26
- Signal-to-noise-and-distortion
 - see SINAD 22
- SINAD 22
 - Querying (remote) 172
 - Troubleshooting 91
- Single sweep
 - Softkey 61
- Slope
 - Trigger 57
- Softkeys
 - AF Center 66
 - AF Filter Config 68
 - AF Full Span 66
 - AF Span Manual 66
 - AF Start 66
 - AF Stop 66
 - AM (Offline) 55
 - Auto Level 50, 79
 - Center 52, 67
 - Continue Single Sweep 61
 - Continuous Sweep 61
 - Demod Config 63
 - Display Config 78
 - External 54
 - FM (Offline) 55
 - Free Run 54
 - Frequency Config 65
 - Outputs Config 42
 - Overview 38
 - PM (Offline) 55
 - Ref Level 49
 - Ref Level Offset 50
 - RF (Offline) 55
 - Scale Config 71
 - Single Sweep 61
 - Span Manual 67
 - Trigger Offset 56
- Span 67
 - Displayed 12
 - Manual 67
- Specifics for
 - Configuration 39
- Spectrograms
 - Activating/Deactivating 81
 - Size 81
- Spectrum
 - Demodulation 65

- Squelch 45
 - AF 63
 - Level 63
 - Remote control 137
 - State 63
- Standards
 - Predefined 180
 - Presetting 37
 - see Digital standards 36
- Status registers
 - STAT:QUES:POW 103
- Storage location
 - Secure user mode 37
 - Settings 37
- Subwindows
 - Spectrogram 81
- Suffixes
 - Common 97
 - Remote commands 93
- Sweep
 - Aborting 61
 - Settings 60
- Sweep Count 62
- Sweep points
 - Displayed 12
- Sweep Points 62
- T**
- THD 22
 - Querying (remote) 172
 - Troubleshooting 91
 - Unit 75
- Time domain zoom 29, 64
 - Length 65
 - Start 65
 - State 64
 - Time per division 65
- Time per division
 - Displayed 12
 - Time domain zoom 65
- Time trigger
 - Repetition interval 55
- Total harmonic distortion
 - see THD 22
- Traces
 - Detector (remote control) 153
 - Exporting 85
- Trigger
 - Drop-out time 57
 - Holdoff 57
 - Hysteresis 56
 - Offset 56
 - Offset, value range 27
 - Output 47, 57
 - Settings 53
 - Slope 57
- Trigger level 56
 - I/Q Power (remote) 123
 - IF Power (remote) 122
 - RF Power (remote) 123
- Trigger output 46
- Trigger source 54
 - AF 29
 - AM (Offline) 55
 - External 54
 - FM (Offline) 55
- Free Run 54
- I/Q Power 54
- IF Power 55
- PM (Offline) 55
- RF (Offline) 55
- RF Power 55
- Settings 53
- Time 55
- Troubleshooting 91
 - Demodulation bandwidth 91
 - Input overload 103
 - RF Spectrum 91
 - SINAD 91
 - THD 91
- U**
- Units 75
 - Reference level 49, 50
- Upper Level Hysteresis 79
- V**
- Videos 7
- W**
- Weighting filter
 - AF filters 69
- White papers 7
- Window title bar information 11
- Windows
 - Adding (remote) 157
 - Closing (remote) 162
 - Configuring 39
 - Layout (remote) 159
 - Maximizing (remote) 156
 - Querying (remote) 158
 - Replacing (remote) 159
 - Splitting (remote) 156
 - Types (remote) 157
- Y**
- Y-axis
 - Scaling 74
- Z**
- Zero Phase
 - Reference Position (remote) 136
- Zooming
 - Time domain 29, 64