

R&S®FSWP

I/Q Analyzer and Spectrum Monitor

User Manual

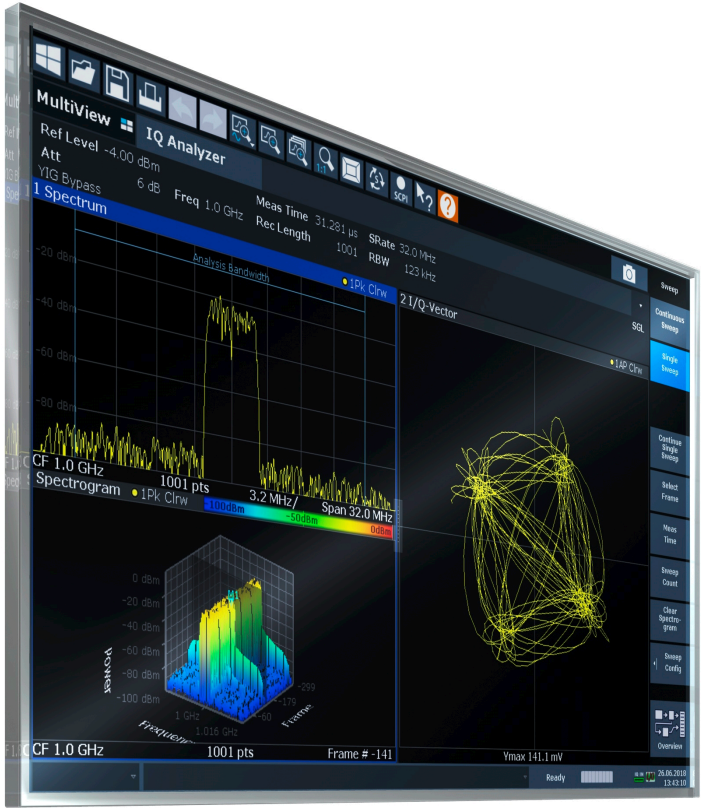

1177585602
Version 11

ROHDE & SCHWARZ
Make ideas real



This manual describes the following R&S®FSWP models with firmware version 4.10 or higher:

- R&S®FSWP8 (1322.8003K08)
- R&S®FSWP8 (1322.8003K09)
- R&S®FSWP26 (1322.8003K26)
- R&S®FSWP26 (1322.8003K27)
- R&S®FSWP50 (1322.8003K50)
- R&S®FSWP50 (1322.8003K51)

The Spectrum Monitor is integral part of the R&S FSWP and is always available with firmware versions 1.60 and higher.

The full I/Q Analyzer is integral part of the following options:

- R&S FSWP-B1 (1322.9997.08)
- R&S FSWP-B1 (1322.9997.26)
- R&S FSWP-B1 (1322.9997.50)

© 2025 Rohde & Schwarz

Muehldorfstr. 15, 81671 Muenchen, Germany

Phone: +49 89 41 29 - 0

Email: info@rohde-schwarz.com

Internet: www.rohde-schwarz.com

Subject to change – data without tolerance limits is not binding.

R&S® is a registered trademark of Rohde & Schwarz GmbH & Co. KG.

Trade names are trademarks of the owners.

1177.5856.02 | Version 11 | R&S®FSWP

Throughout this manual, products from Rohde & Schwarz are indicated without the ® symbol , e.g. R&S®FSWP is indicated as R&S FSWP.

Contents

1	Preface	9
1.1	About this manual	9
1.2	Documentation overview	10
1.2.1	Getting started manual.....	10
1.2.2	User manuals and help.....	10
1.2.3	Service manual.....	10
1.2.4	Instrument security procedures.....	10
1.2.5	Printed safety instructions.....	11
1.2.6	Specifications and brochures.....	11
1.2.7	Release notes and open source acknowledgment (OSA).....	11
1.2.8	Application notes, application cards, white papers, etc.....	11
1.2.9	Videos.....	11
1.3	Conventions used in the documentation	11
1.3.1	Typographical conventions.....	11
1.3.2	Conventions for procedure descriptions.....	12
1.3.3	Notes on screenshots.....	12
2	Welcome to the I/Q Analyzer application	13
2.1	Starting the I/Q Analyzer application	14
2.2	Understanding the display information	15
3	Measurement and result displays	18
4	Basics on I/Q data acquisition and processing	23
4.1	Processing analog I/Q data from RF input	23
4.1.1	Sample rate and maximum usable I/Q bandwidth for RF input.....	25
4.1.1.1	Bandwidth extension options.....	25
4.1.1.2	Relationship between sample rate, record length and usable I/Q bandwidth.....	26
4.1.1.3	R&S FSWP without additional bandwidth extension options.....	27
4.1.1.4	R&S FSWP with I/Q bandwidth extension option B80.....	27
4.1.1.5	R&S FSWP with activated I/Q bandwidth extension option B320.....	28
4.2	Basics on input from I/Q data files	29
4.3	Receiving and providing trigger signals	30

4.4	I/Q data import and export.....	31
4.5	Basics on FFT.....	32
4.5.1	Window functions.....	32
4.5.2	Overlapping.....	33
4.5.3	Dependencies between FFT parameters.....	35
4.5.4	Frequency resolution of FFT results - RBW.....	36
4.5.5	FFT calculation methods.....	37
4.6	I/Q analyzer in MSRA operating mode.....	38
4.7	Measurements in the time and frequency domain.....	39
5	Configuration.....	40
5.1	Configuration overview.....	40
5.2	Import/export functions.....	42
5.3	Configuring data inputs and outputs.....	47
5.3.1	Inputs.....	47
5.3.1.1	RF input.....	47
5.3.1.2	Power sensors.....	49
5.3.1.3	External generators.....	49
5.3.1.4	Probes.....	49
5.3.1.5	External mixers.....	49
5.3.1.6	Settings for input from I/Q data files.....	49
5.3.2	Outputs.....	50
5.4	Configuring the amplitude.....	53
5.4.1	Configuring level characteristics.....	53
5.4.2	Scaling the level axis.....	56
5.5	Configuring frequency characteristics.....	58
5.6	Configuring triggered measurements.....	60
5.7	Data acquisition and bandwidth settings.....	64
5.7.1	Data acquisition.....	64
5.7.2	Sweep settings.....	70
5.8	Display configuration.....	72
5.9	Adjusting settings automatically.....	73
6	Analysis.....	76
6.1	Trace configuration.....	76

6.2	Marker settings.....	77
6.3	Display lines and limit lines.....	77
7	How to work with I/Q data.....	79
7.1	How to perform measurements in the I/Q Analyzer application.....	79
7.1.1	How to capture baseband (I/Q) data as RF input.....	79
7.1.2	How to analyze data in the I/Q Analyzer.....	80
7.2	How to export and import I/Q data.....	80
8	Remote commands for the I/Q analyzer.....	83
8.1	Introduction.....	83
8.1.1	Conventions used in descriptions.....	83
8.1.2	Long and short form.....	84
8.1.3	Numeric suffixes.....	84
8.1.4	Optional keywords.....	85
8.1.5	Alternative keywords.....	85
8.1.6	SCPI parameters.....	85
8.1.6.1	Numeric values.....	86
8.1.6.2	Boolean.....	87
8.1.6.3	Character data.....	87
8.1.6.4	Character strings.....	87
8.1.6.5	Block data.....	87
8.2	Common suffixes.....	88
8.3	Activating I/Q analyzer measurements.....	89
8.4	Performing measurements.....	95
8.5	Retrieving results.....	102
8.5.1	Retrieving captured I/Q data.....	103
8.5.2	Retrieving I/Q trace data.....	106
8.5.3	Retrieving marker and peak search results.....	111
8.6	Configuring I/Q analyzer measurements.....	114
8.6.1	Configuring input sources.....	114
8.6.2	Configuring outputs.....	119
8.6.3	Configuring level characteristics.....	120
8.6.4	Configuring the attenuator.....	122
8.6.5	Configuring the preamplifier.....	123

8.6.6	Scaling the Y-Axis.....	124
8.6.7	Configuring the frequency.....	126
8.6.8	Configuring trigger.....	128
8.6.9	Configuring trigger output.....	133
8.6.10	Configuring gated measurements.....	135
8.6.11	Configuring data acquisition.....	137
8.6.12	Automatic configuration.....	145
8.6.13	Configuring the result display.....	148
8.7	Analyzing results.....	156
8.8	Importing and exporting I/Q data.....	157
8.9	Querying the status registers.....	158
8.10	Programming examples.....	159
8.10.1	I/Q analysis with graphical evaluation.....	159
8.10.2	Basic I/Q analysis with improved performance.....	160
	Annex.....	162
A	Annex: reference.....	162
A.1	Formats for returned values: ASCII format and binary format.....	163
A.2	Reference: format description for I/Q data files.....	163
A.3	Reference: supported I/Q file formats.....	165
A.3.1	I/Q data file format (iq-tar).....	166
A.3.1.1	I/Q parameter XML file specification.....	167
	Minimum data elements.....	168
	Example.....	169
A.3.1.2	I/Q data binary file.....	171
A.3.2	CSV file format.....	174
A.3.2.1	Mandatory data elements.....	174
A.3.2.2	Optional data elements.....	174
A.3.2.3	Example.....	175
A.3.2.4	Simple CSV format.....	176
A.3.3	IQW file format.....	176
A.3.4	Matlab® v. 4 / v. 7.3 file format.....	177
A.3.4.1	Mandatory data elements.....	177
A.3.4.2	Optional data elements.....	178

A.3.4.3	Example.....	179
A.3.4.4	Simple matlab® format.....	179
A.3.5	AID format.....	180
A.3.5.1	Data body.....	182
A.3.6	WV format.....	189
A.3.6.1	Mandatory elements.....	189
A.3.6.2	Optional elements.....	190
	List of Remote Commands (I/Q Analyzer).....	191
	Index.....	194

1 Preface

1.1 About this manual

This R&S FSWP I/Q Analyzer User Manual provides all the information **specific to the application and processing I/Q data**. All general instrument functions and settings common to all applications are described in the main R&S FSWP User Manual.

The main focus in this manual is on the measurement results and the tasks required to obtain them. The following topics are included:

- **Welcome to the I/Q Analyzer application**
Introduction to and getting familiar with the application
- **Typical Applications for the I/Q Analyzer and optional input interfaces**
Example measurement scenarios for I/Q data import and analysis
- **Measurements and Result Displays**
Details on supported measurements and their result types
- **Basics on I/Q Data Acquisition**
Background information on basic terms and principles in the context of the I/Q Analyzer application as well as processing I/Q data in general
- **Configuration and Analysis**
A concise description of all functions and settings available to import, capture and analyze I/Q data in the I/Q Analyzer, with or without optional interfaces, with their corresponding remote control command
- **How to Work with I/Q Data**
The basic procedure to perform an I/Q Analyzer measurement or capture data via the R&S "Digital Baseband" interface with step-by-step instructions
- **Optimizing and Troubleshooting the Measurement**
Hints and tips on how to handle errors and optimize the test setup
- **Remote Commands to perform Measurements with I/Q Data**
Remote commands required to configure and perform I/Q Analyzer measurements or process digital I/Q data in a remote environment, sorted by tasks;
(Commands required to set up the environment or to perform common tasks on the instrument are provided in the main R&S FSWP User Manual.)
Programming examples demonstrate the use of many commands and can usually be executed directly for test purposes.
- **Annex**
Reference material, e.g. I/Q file formats and a detailed description of the LVDS connector
- **List of remote commands**
Alphabetical list of all remote commands described in the manual
- **Index**

1.2 Documentation overview

This section provides an overview of the R&S FSWP user documentation. Unless specified otherwise, you find the documents at:

www.rohde-schwarz.com/manual/FSWP

1.2.1 Getting started manual

Introduces the R&S FSWP and describes how to set up and start working with the product. Includes basic operations, typical measurement examples, and general information, e.g. safety instructions, etc.

A printed version is delivered with the instrument. A PDF version is available for download on the Internet.

1.2.2 User manuals and help

The user manual contains the description of all instrument modes and functions. It also provides an introduction to remote control, a complete description of the remote control commands with programming examples, and information on maintenance, instrument interfaces and error messages. Includes the contents of the getting started manual.

The contents of the user manual are available as help in the R&S FSWP. The help offers quick, context-sensitive access to the complete information for the instrument and its firmware.

The user manual is also available for download or for immediate display on the Internet.

1.2.3 Service manual

Describes the performance test for checking the rated specifications, module replacement and repair, firmware update, troubleshooting and fault elimination, and contains mechanical drawings and spare part lists.

The service manual is available for registered users on the global Rohde & Schwarz information system (GLORIS):

<https://gloris.rohde-schwarz.com>

1.2.4 Instrument security procedures

Deals with security issues when working with the R&S FSWP in secure areas. It is available for download on the internet.

1.2.5 Printed safety instructions

Provides safety information in many languages. The printed document is delivered with the product.

1.2.6 Specifications and brochures

The specifications document, also known as the data sheet, contains the technical specifications of the R&S FSWP. It also lists the firmware applications and their order numbers, and optional accessories.

The brochure provides an overview of the instrument and deals with the specific characteristics.

See www.rohde-schwarz.com/brochure-datasheet/FSWP

1.2.7 Release notes and open source acknowledgment (OSA)

The release notes list new features, improvements and known issues of the current software version, and describe the software installation.

The software uses several valuable open source software packages. An open source acknowledgment document provides verbatim license texts of the used open source software.

See www.rohde-schwarz.com/firmware/FSWP

1.2.8 Application notes, application cards, white papers, etc.

These documents deal with special applications or background information on particular topics.

See www.rohde-schwarz.com/application/FSWP

1.2.9 Videos

Find various videos on Rohde & Schwarz products and test and measurement topics on YouTube: <https://www.youtube.com/@Rohde-Schwarz>

1.3 Conventions used in the documentation

1.3.1 Typographical conventions

The following text markers are used throughout this documentation:

Convention	Description
"Graphical user interface elements"	All names of graphical user interface elements on the screen, such as dialog boxes, menus, options, buttons, and softkeys are enclosed by quotation marks.
[Keys]	Key and knob names are enclosed by square brackets.
Filenames, commands, program code	Filenames, commands, coding samples and screen output are distinguished by their font.
<i>Input</i>	Input to be entered by the user is displayed in italics.
Links	Links that you can click are displayed in blue font.
"References"	References to other parts of the documentation are enclosed by quotation marks.

1.3.2 Conventions for procedure descriptions

When operating the instrument, several alternative methods may be available to perform the same task. In this case, the procedure using the touchscreen is described. Any elements that can be activated by touching can also be clicked using an additionally connected mouse. The alternative procedure using the keys on the instrument or the on-screen keyboard is only described if it deviates from the standard operating procedures.

The term "select" may refer to any of the described methods, i.e. using a finger on the touchscreen, a mouse pointer in the display, or a key on the instrument or on a keyboard.

1.3.3 Notes on screenshots

When describing the functions of the product, we use sample screenshots. These screenshots are meant to illustrate as many as possible of the provided functions and possible interdependencies between parameters. The shown values may not represent realistic usage scenarios.

The screenshots usually show a fully equipped product, that is: with all options installed. Thus, some functions shown in the screenshots may not be available in your particular product configuration.

2 Welcome to the I/Q Analyzer application

The R&S FSWP I/Q Analyzer is a firmware application that adds functionality to perform I/Q data acquisition and analysis to the R&S FSWP.

The R&S FSWP I/Q Analyzer features:

- Acquisition of analog I/Q data
- Import of stored I/Q data from other applications
- Spectrum, magnitude, I/Q vector and separate I and Q component analysis of any I/Q data on the instrument
- Export of I/Q data to other applications



Availability of the I/Q Analyzer and Spectrum Monitor

The full I/Q Analyzer becomes available when you equip the R&S FSWP with the optional Spectrum Analyzer hardware (R&S FSWP-B1).

You can still analyze I/Q data without this hardware option in the Spectrum Monitor application.

It runs on the phase noise analyzer hardware and is available for free with firmware version 1.60.

Compared to the full I/Q analyzer, which runs on the optional spectrum analyzer hardware, it has the following characteristics and limitations.

- When you open a spectrum monitor, the frequency, level and input parameters are initially adopted from the phase noise application (you can change them in the spectrum monitor, of course).
Those settings are the same as in the full I/Q analyzer.
- Maximum analysis bandwidth of 20 MHz and sample rate of 25 MHz (and no support of bandwidth extensions).
- Advanced data acquisition settings are unavailable.
- I/Q data import and export are the same as in the full I/Q analyzer.
- Spectrograms, general marker functionality, marker functions and limit lines are the same as in the full I/Q analyzer.
- Only external triggers are supported.
- Only evaluation of the frequency spectrum is supported.
- Trace mathematics are not available.

All other functionality is the same as that of the I/Q analyzer.

This user manual contains a description of the functionality that the application provides, including remote control operation.

All functions not discussed in this manual are the same as in the base unit and are described in the R&S FSWP User Manual. The latest version is available for download at the product homepage <http://www.rohde-schwarz.com/product/fswp>.

Additional information

Several application notes discussing I/Q analysis are available from the Rohde & Schwarz website:

[1EF85: Converting R&S I/Q data files](#)

[1EF92: Wideband Signal Analysis](#)

[1MA257: Wideband mm-Wave Signal Generation and Analysis](#)

[1EF84: Differential measurements with Spectrum Analyzers and Probes](#)

Installation

The R&S FSWP I/Q Analyzer application is part of the optional "Spectrum" application and requires no further installation.

2.1 Starting the I/Q Analyzer application

The I/Q Analyzer is an application on the R&S FSWP.

To activate the I/Q Analyzer application

1. Select the [MODE] key.

A dialog box opens that contains all applications currently available on your R&S FSWP.

2. Select the "I/Q Analyzer" item.



The R&S FSWP opens a new channel for the I/Q Analyzer application.

The measurement is started immediately with the default settings.

It can be configured in the I/Q Analyzer "Overview" dialog box, which is displayed when you select the "Overview" softkey from any menu (see [Section 5, "Configuration"](#), on page 40).

Multiple Channels and Sequencer Function

When you activate an application, a new channel is created which determines the measurement settings for that application (channel). The same application can be activated with different measurement settings by creating several channels for the same application.

The number of channels that can be configured at the same time depends on the available memory on the instrument.

Only one measurement can be performed at any time, namely the one in the currently active channel. However, in order to perform the configured measurements consecutively, a Sequencer function is provided.

If activated, the measurements configured in the currently defined channels are performed one after the other in the order of the tabs. The currently active measurement is indicated by a  symbol in the tab label.

The result displays of the individual channels are updated in the tabs (as well as the "MultiView") as the measurements are performed. Sequential operation itself is independent of the currently *displayed* tab.

For details on the Sequencer function see the R&S FSWP User Manual.

2.2 Understanding the display information

The following figure shows a measurement diagram during I/Q Analyzer operation. All different information areas are labeled. They are explained in more detail in the following sections.

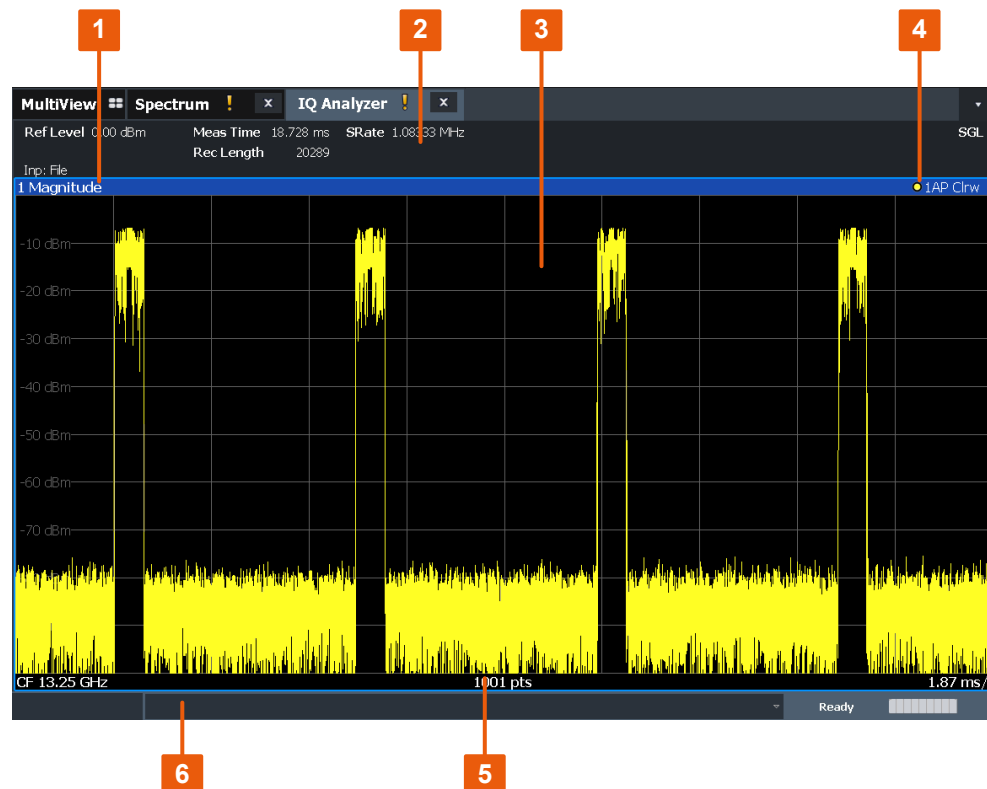

Figure 2-1: Screen elements in the I/Q Analyzer application

- 1+4 = Window title bar with diagram-specific (trace) information
- 2 = Channel bar for firmware and measurement settings
- 3 = Diagram area
- 5 = Diagram footer with diagram-specific information, depending on result display
- 6 = Instrument status bar with error messages and date/time display



MSRA operating mode

In MSRA operating mode, additional tabs and elements are available. A colored background of the screen behind the channel tabs indicates that you are in MSRA operating mode.

For details on the MSRA operating mode see the R&S FSWP MSRA User Manual.

Channel bar information

In the I/Q Analyzer application, the R&S FSWP shows the following settings:

Table 2-1: Information displayed in the channel bar for the I/Q Analyzer application

"Ref Level"	Reference level
"m.+el.Att"	Mechanical and electronic RF attenuation
"Ref Offset"	Reference level offset
"Freq"	Center frequency
"Meas Time"	Measurement time
"Rec Length"	Defined record length (number of samples to capture)
"SRate"	Defined sample rate for data acquisition
"RBW"	(Spectrum evaluation only) Resolution bandwidth calculated from the sample rate and record length

In addition, the channel bar also displays information on instrument settings that affect the measurement results even though this is not immediately apparent from the display of the measured values (e.g. transducer or trigger settings). This information is displayed only when applicable for the current measurement.

For details see the R&S FSWP Getting Started manual.

Window title bar information

For each diagram, the header provides the following information:



Figure 2-2: Window title bar information in the I/Q Analyzer application

- 1 = Window number
- 2 = Window type
- 3 = Trace color
- 4 = Trace number
- 5 = Detector
- 6 = Trace mode

Diagram footer information

The information in the diagram footer (beneath the diagram) depends on the evaluation:

- Center frequency
- Number of sweep points
- Range per division (x-axis)
- Span (Spectrum)

Status bar information

Global instrument settings, the instrument status and any irregularities are indicated in the status bar beneath the diagram.

Furthermore, the progress of the current operation is displayed in the status bar.

3 Measurement and result displays

Access: "Overview" > "Display Config"

Or: [MEAS] > "Display Config"

The I/Q Analyzer can capture I/Q data. The I/Q data that was captured by or imported to the R&S FSWP can then be evaluated in various different result displays. Select the result displays using the SmartGrid functions.

Up to 6 evaluations can be displayed in the I/Q Analyzer at any time, including several graphical diagrams, marker tables or peak lists.

For details on working with the SmartGrid see the R&S FSWP Getting Started manual.



Note that the Spectrum Monitor only supports the "Spectrum" result display.

Measurements in the time and frequency domain

The I/Q Analyzer secondary application (*not primary* in MSRA mode) can also perform measurements on the captured I/Q data in the time and frequency domain (see also [Section 4.6, "I/Q analyzer in MSRA operating mode"](#), on page 38). They are configured using the same settings and provide similar results. In addition, the analysis interval used for the measurement is indicated as in all multistandard applications.

The time and frequency domain measurements and the available results are described in detail in the R&S FSWP User Manual.

Result displays for I/Q data:

Magnitude.....	18
Spectrum.....	19
I/Q-Vector.....	19
Real/Imag (I/Q).....	20
Phase vs. Time.....	21
Marker Table.....	21
Marker Peak List.....	22

Magnitude

Shows the level values in time domain.

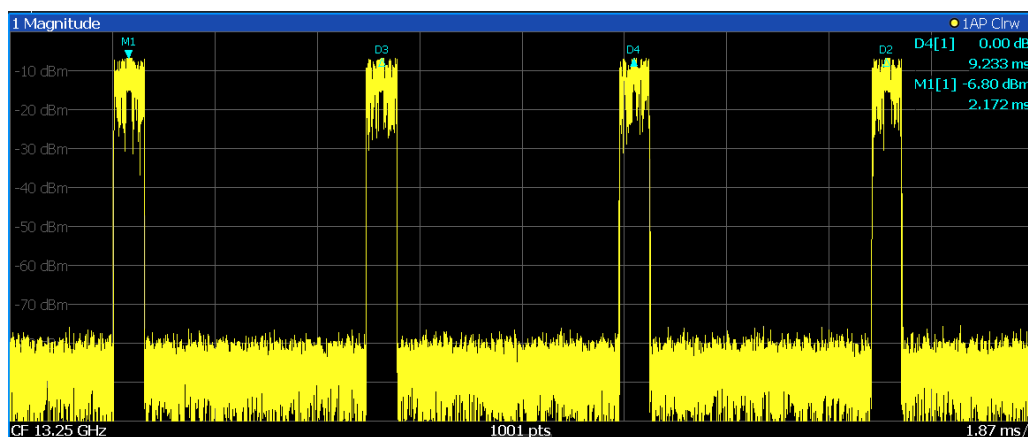

Remote command:

LAY:ADD:WIND? '1', RIGH, MAGN, see [LAYout:ADD\[:WINDow\]?](#) on page 149

Results:

[TRACe<n>\[:DATA\]?](#) on page 109

Spectrum

Displays the frequency spectrum of the captured I/Q samples.

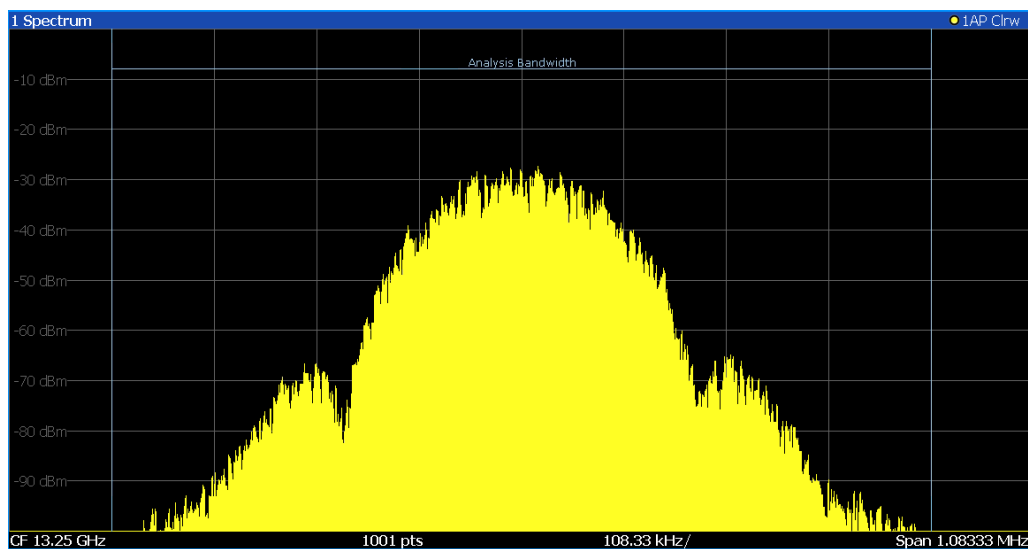

Remote command:

LAY:ADD:WIND? '1', RIGH, FREQ, see [LAYout:ADD\[:WINDow\]?](#) on page 149

Results:

[TRACe<n>\[:DATA\]?](#) on page 109

I/Q-Vector

Displays the captured samples in an I/Q-plot. The samples are connected by a line.

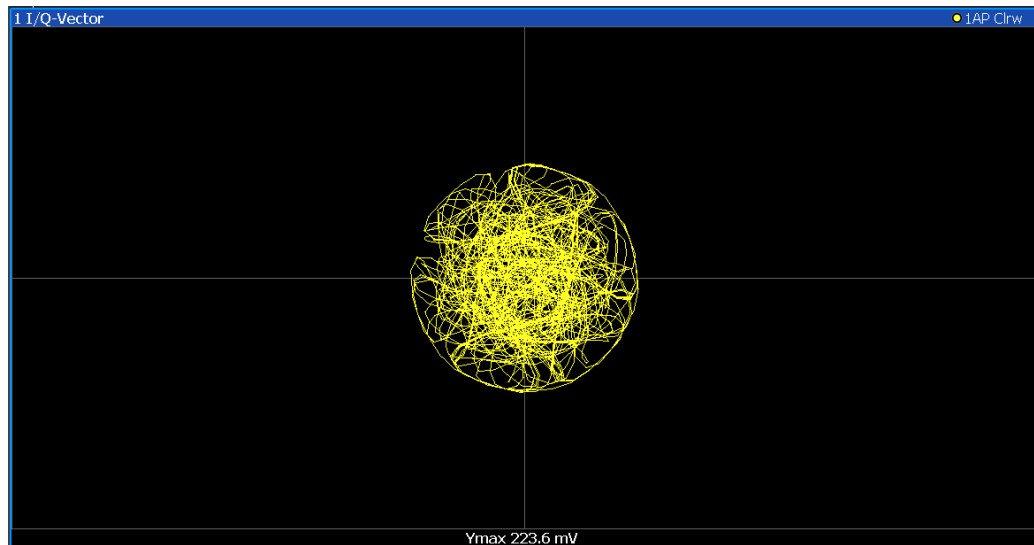

Note: For the I/Q vector result display, the number of I/Q samples to record ("Record Length") must be identical to the number of trace points to be displayed ("Sweep Points"; for I/Q Analyzer: 10001). For record lengths outside the valid range of sweep points the diagram does not show valid results.

Remote command:

LAY:ADD:WIND? '1', RIGH, VECT, see [LAYout:ADD\[:WINDow\]?](#) on page 149

Results:

[TRACe<n>\[:DATA\]?](#) on page 109

Real/Imag (I/Q)

Displays the I and Q values in separate diagrams.

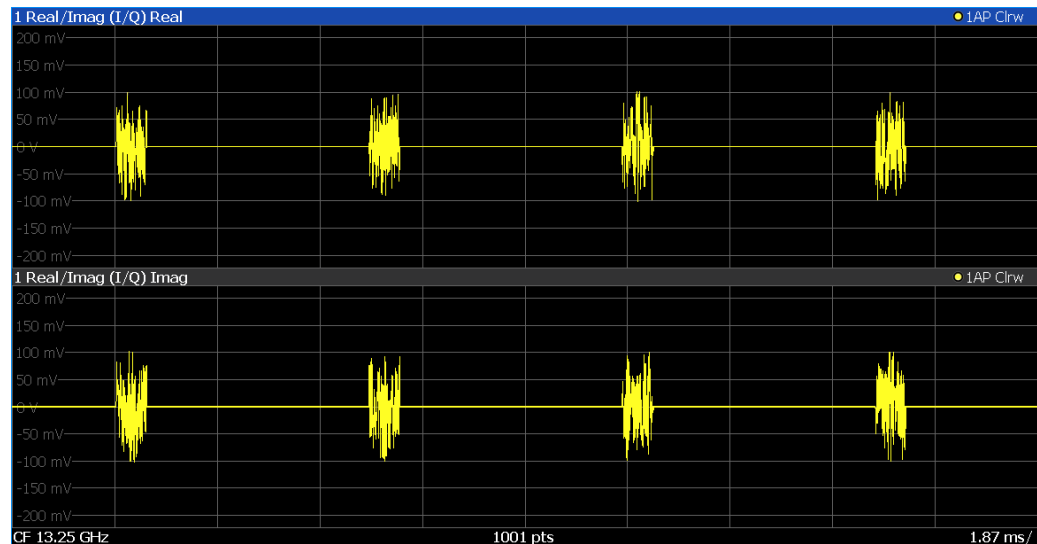

Remote command:

LAY:ADD:WIND? '1', RIGH, RIM, see [LAYout:ADD\[:WINDow\]?](#) on page 149

Results:

[TRACe<n>\[:DATA\]?](#) on page 109

Phase vs. Time

Shows the phase values in the time domain.

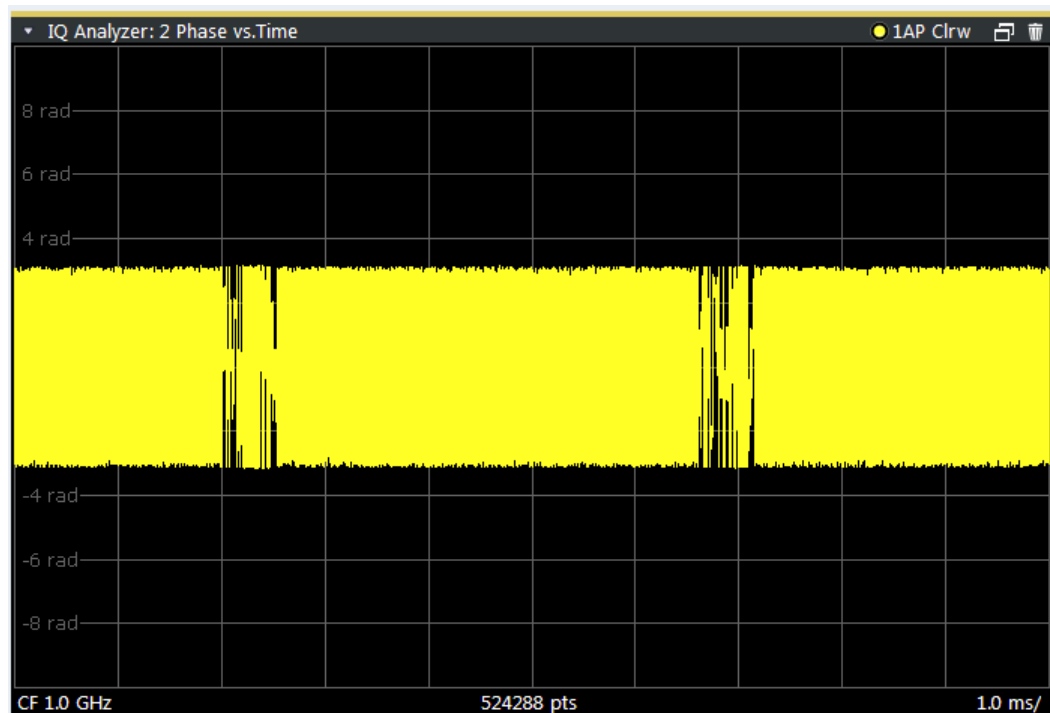

Remote command:

LAY:ADD? '1',RIGH, PHASe, see [LAYout:ADD\[:WINDow\]?](#) on page 149

Marker Table

Displays a table with the current marker values for the active markers.

This table is displayed automatically if configured accordingly.

Type	Shows the marker type and number ("M" for a normal marker, "D" for a delta marker).		
Ref	Shows the reference marker that a delta marker refers to.		
Trace	Shows the trace that the marker is positioned on.		
X- / Y-Value	Shows the marker coordinates (usually frequency and level).		

2 Marker						
Type	Ref	Trc	Stimulus	Response	Function	Function Result
N1		1	13.197 GHz	-25.87 dBm	Count	13.197052
D1	N1	1	-7.942 GHz	-49.41 dB		
D2	N1	2	-3.918 GHz	-21.90 dB		
D3	N1	3	4.024 GHz	-21.99 dB		

Tip: To navigate within long marker tables, simply scroll through the entries with your finger on the touchscreen.

Remote command:

LAY:ADD? '1',RIGH, MTAB, see [LAYout:ADD\[:WINDow\]?](#) on page 149

Results:

[CALCulate<n>:MARKer<m>:X](#) on page 113

[CALCulate<n>:MARKer<m>:Y?](#) on page 113

Marker Peak List

The marker peak list determines the frequencies and levels of peaks in the spectrum or time domain. How many peaks are displayed can be defined, as well as the sort order. In addition, the detected peaks can be indicated in the diagram. The peak list can also be exported to a file for analysis in an external application.

3 Marker Peak List			
Wnd	No	X-Value	Y-Value
2	1	1.086245 ms	-75.810 dBm
2	2	2.172490 ms	-6.797 dBm
2	3	3.258736 ms	-76.448 dBm
2	4	4.831918 ms	-76.676 dBm
2	5	6.255274 ms	-76.482 dBm
2	6	6.798397 ms	-6.800 dBm
2	7	9.233084 ms	-76.519 dBm
2	8	10.075861 ms	-76.172 dBm
2	9	11.405574 ms	-6.801 dBm

Tip: To navigate within long marker peak lists, simply scroll through the entries with your finger on the touchscreen.

Remote command:

LAY:ADD? '1',RIGH, PEAK, see [LAYout:ADD\[:WINDow\]?](#) on page 149

Results:

[CALCulate<n>:MARKer<m>:X](#) on page 113

[CALCulate<n>:MARKer<m>:Y?](#) on page 113

4 Basics on I/Q data acquisition and processing

Some background knowledge on basic terms and principles used when describing I/Q data acquisition on the R&S FSWP in general, and in the I/Q Analyzer application in particular, is provided here for a better understanding of the required configuration settings.

The I/Q Analyzer provides various possibilities to acquire the I/Q data to be analyzed:

- Capturing analog I/Q data from the "RF Input" connector
- Importing I/Q data from a file

Background information for all these scenarios and more is provided in the following sections.

- [Processing analog I/Q data from RF input](#).....23
- [Basics on input from I/Q data files](#)..... 29
- [Receiving and providing trigger signals](#)..... 30
- [I/Q data import and export](#)..... 31
- [Basics on FFT](#)..... 32
- [I/Q analyzer in MSRA operating mode](#).....38
- [Measurements in the time and frequency domain](#)..... 39

4.1 Processing analog I/Q data from RF input

Complex baseband data

In the telephone systems of the past, baseband data was transmitted unchanged as an analog signal. In modern phone systems and in radio communication, however, the baseband data is modulated on a carrier frequency, which is then transmitted. The receiver must demodulate the data based on the carrier frequency. When using modern modulation methods (e.g. QPSK, QAM etc.), the baseband signal becomes complex. Complex data (or: I/Q data) consists of an imaginary (I) and a real (Q) component.

Sweep vs sampling

The standard Spectrum application on the R&S FSWP performs frequency sweeps on the input signal and measurements in the frequency and time domain. Other applications on the R&S FSWP, such as the I/Q Analyzer, sample and process the individual I and Q components of the complex signal.

I/Q Analyzer - processing complex data from RF input

The I/Q Analyzer is a standard application used to capture and analyze I/Q data on the R&S FSWP. By default, it assumes the I/Q data is modulated on a carrier frequency and input via the "RF Input" connector on the R&S FSWP.

The A/D converter samples the IF signal at a rate of 200 MHz. The digital signal is down-converted to the complex baseband, lowpass-filtered, and the sample rate is reduced. The analog filter stages in the analyzer cause a frequency response which adds to the modulation errors. An **equalizer filter** before the **resampler** compensates for this frequency response. The continuously adjustable sample rates are realized using an optimal decimation filter and subsequent resampling on the set sample rate.

A dedicated memory (**capture buffer**) is available in the R&S FSWP for a maximum of 400 Msamples (400*1000*1000) of complex samples (pairs of I and Q data). The number of complex samples to be captured can be defined (for restrictions refer to [Section 4.1.1, "Sample rate and maximum usable I/Q bandwidth for RF input"](#), on page 25).

The block diagram in [Figure 4-1](#) shows the analyzer hardware from the IF section to the processor.

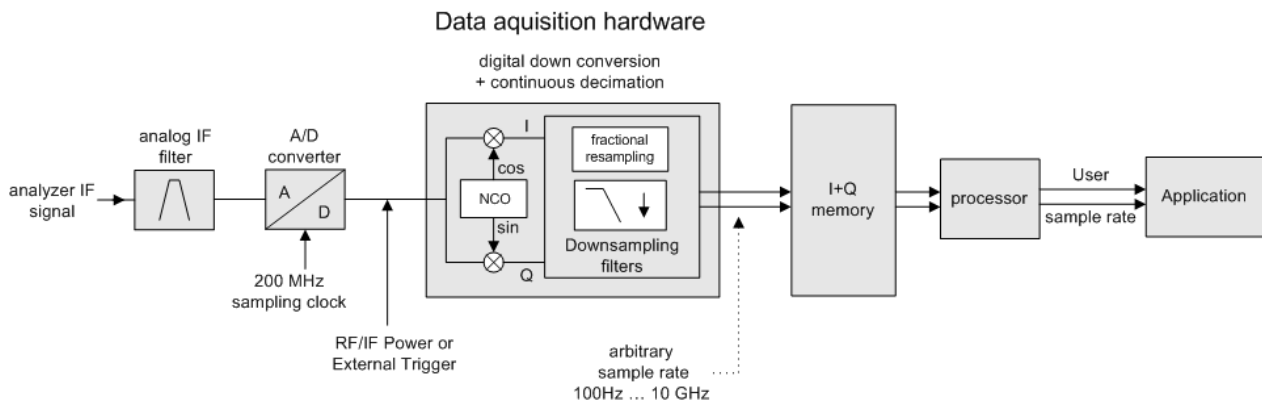

Figure 4-1: Block diagram illustrating the R&S FSWP signal processing for analog I/Q data (without bandwidth extension options)

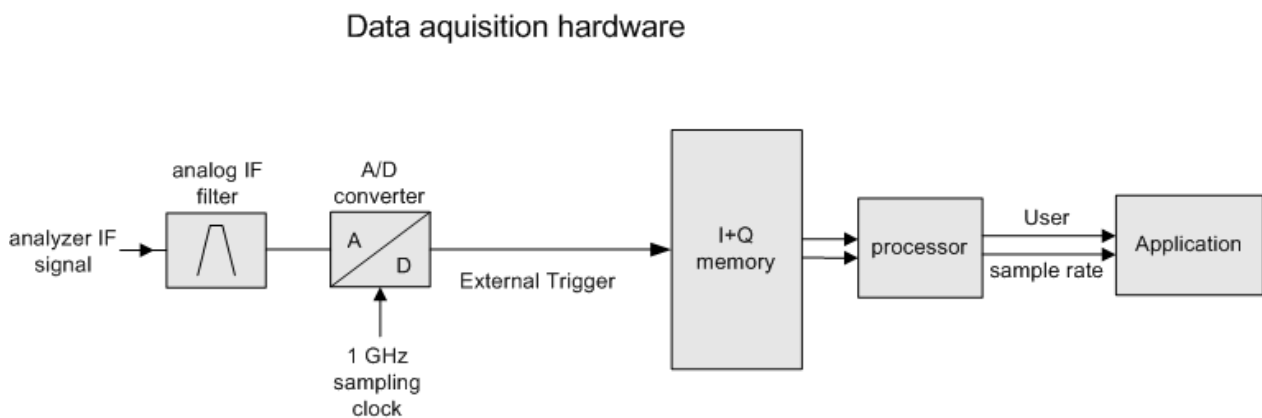

Figure 4-2: Block diagram illustrating the R&S FSWP signal processing for analog I/Q data (with option B320)

4.1.1 Sample rate and maximum usable I/Q bandwidth for RF input

Definitions

- **Input sample rate (ISR):** the sample rate of the useful data provided by the device connected to the input of the R&S FSWP
- (User, Output) **Sample rate (SR):** the user-defined sample rate (e.g. in the "Data Acquisition" dialog box in the "I/Q Analyzer" application) which is used as the basis for analysis or output
- **Usable I/Q (Analysis) bandwidth:** the bandwidth range in which the signal remains undistorted in regard to amplitude characteristic and group delay; this range can be used for accurate analysis by the R&S FSWP
- **Record length:** Number of I/Q samples to capture during the specified measurement time; calculated as the measurement time multiplied by the sample rate

For the I/Q data acquisition, digital decimation filters are used internally in the R&S FSWP. The passband of these digital filters determines the *maximum usable I/Q bandwidth*. In consequence, signals within the usable I/Q bandwidth (passband) remain unchanged, while signals outside the usable I/Q bandwidth (passband) are suppressed. Usually, the suppressed signals are noise, artifacts, and the second IF side band. If frequencies of interest to you are also suppressed, try to increase the output sample rate, which increases the maximum usable I/Q bandwidth.



Bandwidth extension options

You can extend the maximum usable I/Q bandwidth provided by the R&S FSWP in the basic installation by adding options. The maximum bandwidth provided by the individual option is indicated by its number, for example, B40 extends the bandwidth to 40 MHz.

As a rule, the usable I/Q bandwidth is proportional to the output sample rate. Yet, when the I/Q bandwidth reaches the bandwidth of the analog IF filter (at very high output sample rates), the curve breaks.

- [Bandwidth extension options](#)..... 25
- [Relationship between sample rate, record length and usable I/Q bandwidth](#)..... 26
- [R&S FSWP without additional bandwidth extension options](#)..... 27
- [R&S FSWP with I/Q bandwidth extension option B80](#)..... 27
- [R&S FSWP with activated I/Q bandwidth extension option B320](#).....28

4.1.1.1 Bandwidth extension options

Max. usable I/Q BW	Required B-option
80 MHz	B80
320 MHz	B320

4.1.1.2 Relationship between sample rate, record length and usable I/Q bandwidth

Up to the maximum bandwidth, the following rule applies:

$$\text{Usable I/Q bandwidth} = 0.8 * \text{Output sample rate}$$

Regarding the record length, the following rule applies:

$$\text{Record length} = \text{Measurement time} * \text{sample rate}$$

Maximum record length for RF input

The maximum record length, that is, the maximum number of samples that can be captured, depends on the sample rate.

Table 4-1: Maximum record length (without I/Q bandwidth extension options)

Sample rate	Maximum record length
100 Hz to 200 MHz	440 Msamples
200 MHz to 10 GHz (upsampling) MSRA primary: 200 MHz to 600 MHz	220 Msamples



MSRA operating mode

In MSRA operating mode, the MSRA primary is restricted to a sample rate of 600 MHz.

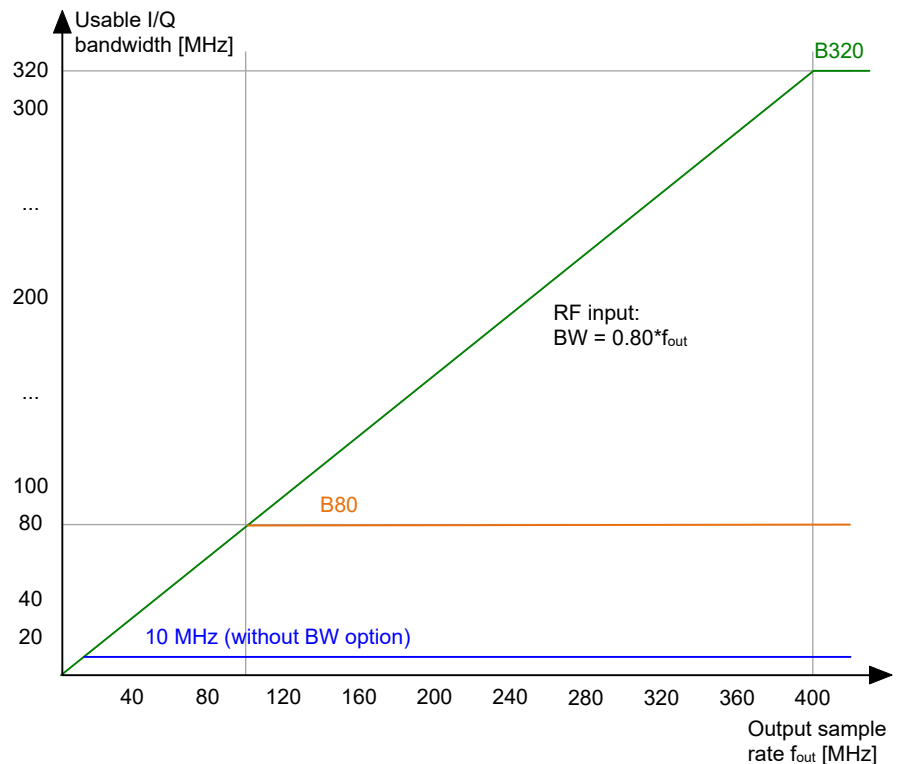

Figure 4-3: Relationship between maximum usable I/Q bandwidth and output sample rate with and without bandwidth extensions

4.1.1.3 R&S FSWP without additional bandwidth extension options

Sample rate: 100 Hz - 20 GHz

Maximum I/Q bandwidth: 10 MHz



MSRA operating mode

In MSRA operating mode, the MSRA primary is restricted to a sample rate of 600 MHz.

Table 4-2: Maximum I/Q bandwidth

Sample rate	Maximum I/Q bandwidth
100 Hz to 10 MHz	Proportional up to maximum 10 MHz
10 MHz to 20 GHz MSRA primary: 10 MHz to 600 MHz	10 MHz

4.1.1.4 R&S FSWP with I/Q bandwidth extension option B80

Sample rate: 100 Hz - 20 GHz

Maximum bandwidth: 80 MHz



MSRA operating mode

In MSRA operating mode, the MSRA primary is restricted to a sample rate of 600 MHz.

Sample rate	Maximum I/Q bandwidth
100 Hz to 100 MHz	Proportional up to maximum 80 MHz
100 MHz to 20 GHz MSRA primary: 100 MHz to 600 MHz	80 MHz

4.1.1.5 R&S FSWP with activated I/Q bandwidth extension option B320

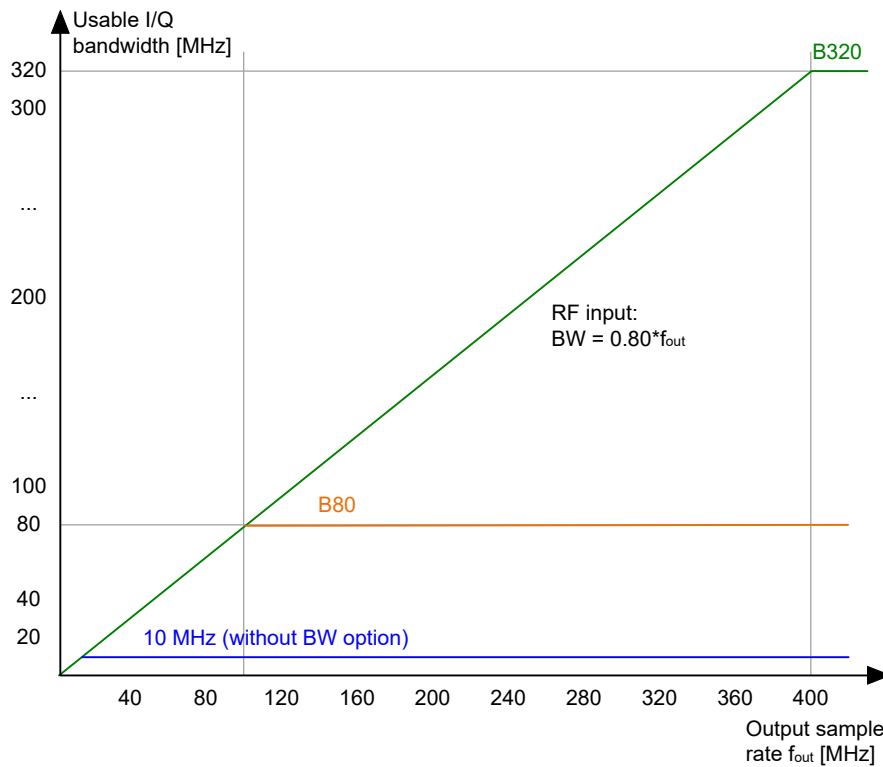

Figure 4-4: Relationship between maximum usable I/Q bandwidth and output sample rate with and without bandwidth extensions

Sample rate	Maximum I/Q bandwidth
100 Hz to 400 MHz	Proportional up to maximum 320 MHz
400 MHz to 20 GHz MSRA primary: 400 MHz to 600 MHz	320 MHz

Table 4-3: Maximum record length with activated I/Q bandwidth extension option B320

Sample rate	Maximum record length
100 Hz to 200 MHz*)	440 Msamples
200 MHz to 468 MHz	470 Msamples * sample rate / 1GHz
468 MHz to 20 GHz MSRA primary: 468 MHz to 600 MHz	220 Msamples
*) for sample rates up to 200 MHz the I/Q Bandwidth Extension B320 is not used	

4.2 Basics on input from I/Q data files

The I/Q data to be evaluated in a particular R&S FSWP application cannot only be captured by the application itself, it can also be loaded from a file, provided it has the correct format. The file is then used as the input source for the application.

For example, you can capture I/Q data using the I/Q Analyzer application, store it to a file, and then analyze the signal parameters for that data later using the AM/FM/PM Modulation Analysis application.

The I/Q data file must be in one of the following supported formats:

- .iq.tar
- .iqw
- .csv
- .mat
- .wv
- .aid



An application note on converting Rohde & Schwarz I/Q data files is available from the Rohde & Schwarz website:

[1EF85: Converting R&S I/Q data files](#)

When importing data from an I/Q data file using the import functions provided by some R&S FSWP applications, the data is only stored temporarily in the capture buffer. It overwrites the current measurement data and is in turn overwritten by a new measurement. If you use an I/Q data file as input, the stored I/Q data remains available for any number of subsequent measurements. Furthermore, the (temporary) data import requires the current measurement settings in the current application to match the settings that were applied when the measurement results were stored (possibly in a different application). When the data is used as an input source, however, the data acquisition settings in the current application (attenuation, center frequency, measurement bandwidth, sample rate) can be ignored. As a result, these settings cannot be changed in the current application. Only the measurement time can be decreased, to perform measurements on an extract of the available data (from the beginning of the file) only.

For input files that contain multiple data streams from different channels, you can define which data stream to be used for the currently selected channel in the input settings. You can define whether the data stream is used only once, or repeatedly, to create a larger amount of input data.

When using input from an I/Q data file, the [RUN SINGLE] function starts a single measurement (i.e. analysis) of the stored I/Q data, while the [RUN CONT] function repeatedly analyzes the same data from the file.



Sample iq.tar files

If you have the optional R&S FSWP VSA application (R&S FSWP-K70), some sample `iq.tar` files are provided in the `C:\R_S\INSTR\USER\vsa\DemoSignals` directory on the R&S FSWP.

Furthermore, you can create your own `iq.tar` files in the I/Q Analyzer, see [Section 7.2, "How to export and import I/Q data"](#), on page 80.

Pre-trigger and post-trigger samples

In applications that use pre-triggers or post-triggers, if no pre-trigger or post-trigger samples are specified in the I/Q data file, or too few trigger samples are provided to satisfy the requirements of the application, the missing pre- or post-trigger values are filled up with zeros. Superfluous samples in the file are dropped, if necessary. For pre-trigger samples, values are filled up or omitted at the beginning of the capture buffer. For post-trigger samples, values are filled up or omitted at the end of the capture buffer.

4.3 Receiving and providing trigger signals

Using one of the "trigger" connectors of the R&S FSWP, the R&S FSWP can use a signal from an external device as a trigger to capture data. Alternatively, the internal trigger signal used by the R&S FSWP can be output for use by other connected devices. Using the same trigger on several devices is useful to synchronize the transmitted and received signals within a measurement.

For details on the connectors see the R&S FSWP "Getting Started" manual.

External trigger as input

If the trigger signal for the R&S FSWP is provided by an external device, the trigger signal source must be connected to the R&S FSWP and the trigger source must be defined as "External" in the R&S FSWP.

Trigger output

The R&S FSWP can provide output to another device either to pass on the internal trigger signal, or to indicate that the R&S FSWP itself is ready to trigger.

The trigger signal can be output by the R&S FSWP automatically, or manually by the user. If it is provided automatically, a high signal is output when the R&S FSWP has

triggered due to a measurement start ("Device Triggered"), or when the R&S FSWP is ready to receive a trigger signal after a measurement start ("Trigger Armed").

Manual triggering

If the trigger output signal is initiated manually, the length and level (high/low) of the trigger pulse is also user-definable. Note, however, that the trigger pulse level is always opposite to the constant signal level defined by the output "Level" setting, e.g. for "Level" = "High", a constant high signal is output to the connector until "Send Trigger" is selected. Then, a low pulse is provided.

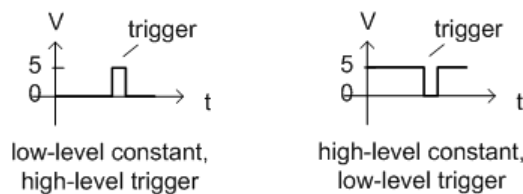

4.4 I/Q data import and export

Baseband signals mostly occur as so-called complex baseband signals, i.e. a signal representation that consists of two channels; the inphase (I) and the quadrature (Q) channel. Such signals are referred to as I/Q signals. The complete modulation information and even distortion that originates from the RF, IF or baseband domains can be analyzed in the I/Q baseband.

Importing and exporting I/Q signals is useful for various applications:



- Generating and saving I/Q signals in an RF or baseband signal generator or in external software tools to analyze them with the R&S FSWP later.
The R&S FSWP supports various I/Q data formats for import.
See [Section A.3, "Reference: supported I/Q file formats"](#), on page 165.
- Capturing and saving I/Q signals with the R&S FSWP to analyze them with the R&S FSWP or an external software tool later
As opposed to storing trace data, which can be averaged or restricted to peak values, I/Q data is stored as it was captured, without further processing. Multi-channel data is not supported.
The data is stored as complex values in 32-bit floating-point format.
The file type is determined by the file extension. If no file extension is provided, the file type is assumed to be `.iq.tar`. For `.mat` files, Matlab® v4 is assumed.

For example, you can capture I/Q data using the I/Q Analyzer application and then perform analog demodulation on that data using the R&S FSWP Analog Demodulation application, if available.



An application note on converting Rohde & Schwarz I/Q data files is available from the Rohde & Schwarz website:

[1EF85: Converting R&S I/Q data files](#)

The import and export functions are available in the "Save/Recall" menu which is displayed when you select the  "Save" or  "Open" icon in the toolbar.

See [Section 5.2, "Import/export functions"](#), on page 42.



Export only in MSRA mode

In MSRA mode, I/Q data can only be exported to other applications; I/Q data cannot be imported to the MSRA primary or any MSRA secondary applications.

4.5 Basics on FFT

The I/Q Analyzer measures the power of the signal input over time. To convert the time domain signal to a frequency spectrum, an FFT (Fast Fourier Transformation) is performed which converts a vector of input values into a discrete spectrum of frequencies.

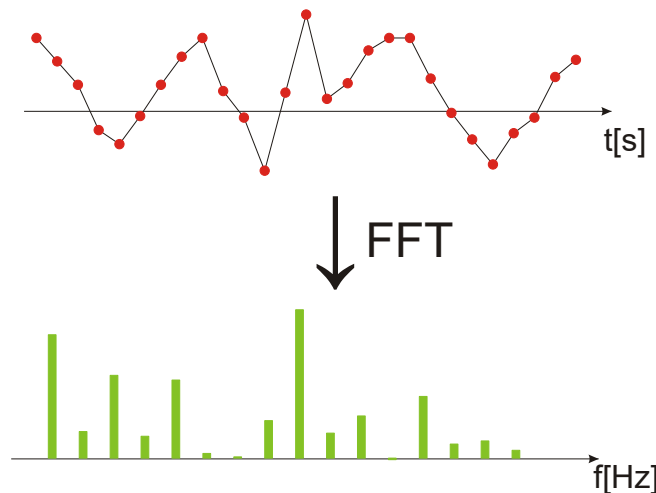

4.5.1 Window functions

The Fourier transformation is not performed on the entire captured data in one step. Only a limited number of samples is used to calculate an individual result. This process is called windowing.

After sampling in the time domain, each window is multiplied with a specific window function. Windowing helps minimize the discontinuities at the end of the measured signal interval and thus reduces the effect of spectral leakage, increasing the frequency resolution.

Various different window functions are provided in the R&S FSWP to suit different input signals. Each of the window functions has specific characteristics, including some advantages and some trade-offs. Consider these characteristics to find the optimum solution for the measurement task.



Ignoring the window function - rectangular window

The rectangular window function is in effect not a function at all, it maintains the original sampled data. This may be useful to minimize the required bandwidth. However, be aware that if the window does not contain exactly one period of your signal, heavy sidelobes may occur, which do not exist in the original signal.

Table 4-4: Characteristics of typical FFT window functions

Window type	Frequency resolution	Magnitude resolution	Sidelobe suppression	Measurement recommendation
Rectangular	Best	Worst	Worst	No function applied. Separation of two tones with almost equal amplitudes and a small frequency distance
Blackman-Harris (default)	Good	Good	Good	Harmonic detection and spurious emission detection
Gauss (Alpha = 0.4)	Good	Good	Good	Weak signals and short duration
Flattop	Worst	Best	Good	Accurate single tone measurements
5-Term	Good	Good	Best	Measurements with very high dynamic range

4.5.2 Overlapping

The I/Q Analyzer calculates multiple FFTs per measurement by dividing one captured record into several windows. Furthermore, the I/Q Analyzer allows consecutive windows to overlap. Overlapping "reuses" samples that were already used to calculate the preceding FFT result.

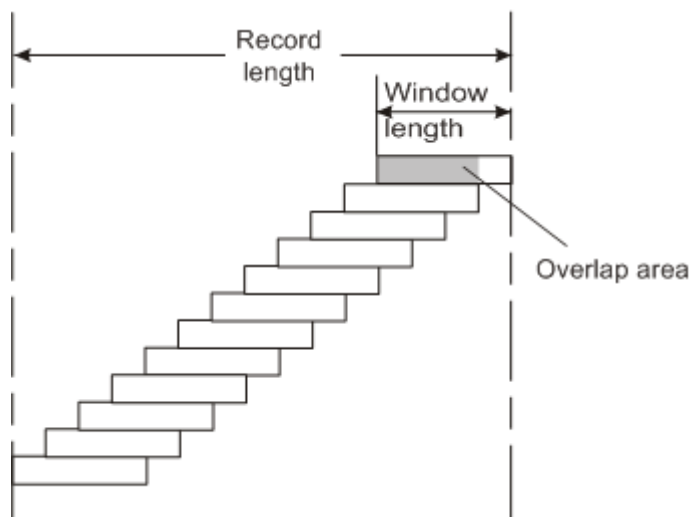

In advanced FFT mode with averaging, the overlapping factor can be set freely. The higher the overlap factor, the more windows are used. This leads to more individual results and improves detection of transient signal effects. However, it also extends the

duration of the calculation. The size of the window can be defined manually according to the record length, the overlap factor, and the FFT length.

An FFT overlap of 67%, for example, means the second FFT calculation uses the last 67% of the data of the first FFT. It uses only 33% new data. The third FFT still covers 33% of the first FFT and 67% of the second FFT, and so on.

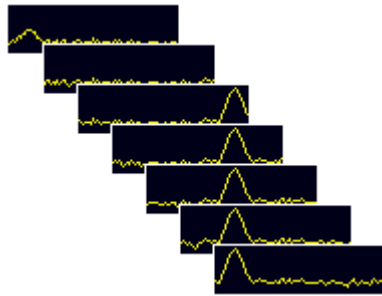

Figure 4-5: Overlapping FFTs

In "Manual" or "Auto" FFT mode, an FFT length of 4096 and a window length of 4096 (or the record length, if shorter) is used to calculate the spectrum.

Combining results - trace detector

If the record length permits, multiple overlapping windows are calculated and combined to create the final spectrum using the selected trace detector. If necessary, the trace detector is also used to reduce the number of calculated frequency points (defined by the FFT length) to the defined number of measurement points. By default, the Auto-peak trace detector is used.



Since the frequency points are reduced to the number of measurement points, using a detector other than "Auto Peak" and fewer than 4096 measurement points can lead to false level results.

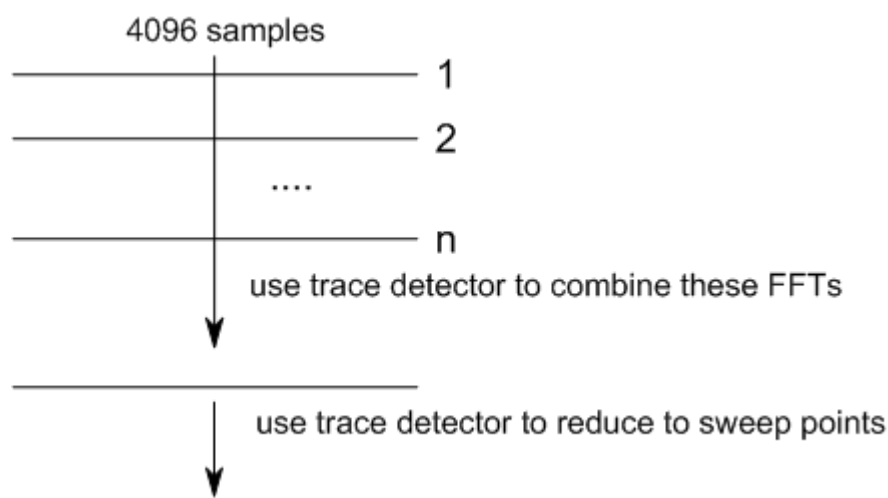

4.5.3 Dependencies between FFT parameters

FFT analysis in the R&S FSWP is highly configurable. Several parameters, including the resolution bandwidth, record length, and FFT length, are user-definable. Note, however, that several parameters are correlated and not all can be configured independently of the others.

Record Length

Defines the number of I/Q samples to capture. By default, the number of measurement points is used. The record length is calculated as the measurement time multiplied by the sample rate.

If you change the record length, the [Meas Time](#) is automatically changed, as well.

For FFTs using only a single window ("Single" mode), the record length (which is then identical to the FFT length) must not exceed 512k.

FFT Length

Defines the number of frequency points determined by each FFT calculation. The more points are used, the higher the resolution in the spectrum becomes, but the longer the calculation takes.

In "Auto" or "Manual" mode, an FFT length of 4096 is used.

In advanced FFT mode, the FFT length is user-definable. If you use the arrow keys or the rotary knob to change the FFT length, the value is incremented or decremented by powers of 2. If you enter the value manually, any integer value from 3 to 524288 is available.

If the FFT length is longer than the [Window Length](#) the sample data is filled up with zeros up to the FFT length. The FFT is then performed using interpolated frequency points.

For an FFT length that is not a power of 2, a DFT (discrete Fourier transform) is performed, which requires more time for calculation, but avoids the effects of interpolation.

To display all calculated frequency points (defined by the FFT length), the number of measurement points is set to the FFT length automatically in advanced FFT mode.

Window Length

Defines the number of samples to be included in a single window in averaging mode. (In single mode, the window length corresponds to the ["Record Length"](#) on page 67.)

Values from 3 to 4096 are available in "Manual" mode; in "Advanced" FFT mode, values from 3 to 524288 are available. However, the window length must not be longer than the [FFT Length](#).

If the window length is shorter than the [FFT Length](#), the sample data is filled up with zeros up to the FFT length.

If the window length is longer than the [Record Length](#) (that is, not enough samples are available), a window length the size of the [Record Length](#) is used for calculation.

The window length and the [Window Overlap](#) determine how many FFT calculations must be performed for each record in averaging mode (see "[Transformation Algorithm](#)" on page 68).

4.5.4 Frequency resolution of FFT results - RBW

The **resolution bandwidth** defines the minimum frequency separation at which the individual components of a spectrum can be distinguished. Small values result in high precision, as the distance between two distinguishable frequencies is small. Higher values decrease the precision, but increase measurement speed.

The RBW is determined by the following equation:

$$RBW = \text{Normalized Bandwidth} * \frac{\text{Sample Rate}}{\text{Window Length}}$$

Equation 4-1: Definition of RBW

(Note: The normalized bandwidth is a fixed value that takes the noise bandwidth of the window function into consideration.)

If a higher spectral resolution is required, the number of samples must be increased by using a higher sample rate or longer record length.

The minimum achievable RBW depends on the sample rate and record length, according to the following equation:

$$RBW_{min} = \frac{\text{Normalized Bandwidth} * \text{Sample Rate}}{\min(4096, \text{Record Length})}$$

To simplify operation, some parameters are coupled and automatically calculated, such as record length and RBW.

RBW mode

Depending on the selected RBW mode, the resolution bandwidth is either determined automatically or can be defined manually.

Auto mode:

This is the default mode in the I/Q Analyzer. The RBW is determined automatically depending on the [Sample Rate](#) and [Window Length](#), where the window length corresponds to the [Record Length](#), or a maximum of 4096.

If the record length is larger than the window length, multiple windows are combined; the FFT length is 4096.

A Flatop window function is used.

Manual mode:

The RBW is user-definable.

The **Window Length** is adapted to comply with [Equation 4-1](#). Since only window lengths with integer values can be employed, the **Sample Rate** is adapted, if necessary, to obtain an integer window length value.

If the record length is larger than the window length, multiple windows are combined; the FFT length is 4096.

A Flatop window function is used.

Advanced FFT mode

The RBW is determined by the [advanced FFT parameters](#), depending on the selected [FFT calculation methods](#) method.

4.5.5 FFT calculation methods

FFT calculation can be performed using different methods.

Single

In single mode, one FFT is calculated for the entire record length, that means the window length is identical to the record length.

If the defined **FFT Length** is larger than the record length, zeros are appended to the captured data to reach the FFT length.



Figure 4-6: FFT parameters for single FFT calculation

Averaging

In averaging mode, several overlapping FFTs are calculated for each record; the results are combined to determine the final FFT result for the record.

The number of FFTs to be combined is determined by the **Window Overlap** and the **Window Length**.



Figure 4-7: FFT parameters for averaged FFT calculation

4.6 I/Q analyzer in MSRA operating mode

The I/Q Analyzer can also be used in MSRA operating mode. The MSRA primary channel is implemented as an I/Q Analyzer application. Only this channel captures data in MSRA mode. Thus, the functions and settings described for data acquisition in the I/Q Analyzer application also apply to the MSRA primary. Furthermore, the I/Q Analyzer can be used to analyze data in MSRA mode. Thus, the result displays and analysis functions provided by the I/Q Analyzer can also be used in MSRA mode.

Note that the available functions and settings for the I/Q Analyzer in MSRA mode vary depending on whether the MSRA primary channel or an I/Q Analyzer application channel is selected. For example, data acquisition settings for an I/Q Analyzer **application** channel in MSRA mode configure the analysis interval, not an actual data capture from the input signal. And measurements in the time and frequency domain are only available in an I/Q Analyzer **application** channel in MSRA mode.

Analysis line

A frequent question when analyzing multi-standard signals is how each data channel is correlated (in time) to others. Thus, an analysis line has been introduced. The analysis line is a common time marker for all MSRA secondary applications. It can be positioned in any MSRA secondary application or the MSRA primary and is then adjusted in all other secondary applications. Thus, you can easily analyze the results at a specific time in the measurement in all secondary applications and determine correlations.

If the analysis interval of the secondary application contains the marked point in time, the line is indicated in all time-based result displays, such as time, symbol, slot or bit diagrams. By default, the analysis line is displayed. However, you can hide it from view manually. In all result displays, the "AL" label in the window title bar indicates whether the analysis line lies within the analysis interval or not:

- **orange "AL"**: the line lies within the interval
- **white "AL"**: the line lies within the interval, but is not displayed (hidden)
- **no "AL"**: the line lies outside the interval

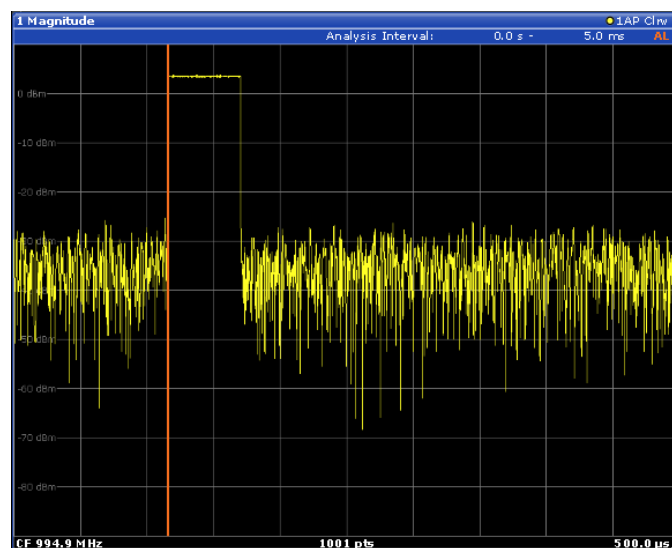

For details on the MSRA operating mode see the R&S FSWP MSRA User Manual.

4.7 Measurements in the time and frequency domain

The I/Q Analyzer secondary application (*not Primary*) in **multistandard mode** can also perform measurements on the captured I/Q data in the time and frequency domain. In order to do so, the I/Q Analyzer performs an FFT sweep on the captured I/Q data, providing power vs frequency results, or uses the RBW filter to obtain power vs time (zero span) results. This data is then used for the common frequency or time domain measurements provided by the R&S FSWP Spectrum application, such as ACLR, SEM or CCDF.

Configuration

Apart from the data capturing process, the measurements are identical in the Spectrum and I/Q Analyzer secondary applications. They are configured using the same settings and provide the same results. The "Magnitude" result display in the I/Q Analyzer, for instance, will principally show the same results as the zero span measurement for the same data. However, while the "Magnitude" evaluation is configured by the I/Q analysis bandwidth and the measurement time, the zero span measurement is configured by the center frequency, RBW and sweep time settings. Internally, these "time domain" settings are converted to the required I/Q settings by the I/Q Analyzer.

The time and frequency domain measurements and the required settings are described in detail in the R&S FSWP User Manual.

Limitations

However, since the data in the I/Q Analyzer secondary application is captured by the Primary, independently of the specific time or frequency measurement requirements concerning the RBW, filter type and number of sweep points in the secondary application, some restrictions may apply to these measurements in the I/Q Analyzer. If not enough samples are available in the captured and converted I/Q data, for example, an error message is displayed in the secondary application.

The **maximum span** for a frequency sweep on I/Q-based data corresponds to the maximum I/Q bandwidth.

The **maximum resolution bandwidth (RBW)** is 1 MHz.

Furthermore, the following **functions** are not available for time and frequency domain measurements in multistandard mode:

- Marker demodulation
- Frequency counter marker
- Gated measurement
- Video trigger

5 Configuration

The I/Q Analyzer is a special application on the R&S FSWP, which you activate using the [MODE] key on the front panel.

When you switch to an I/Q Analyzer measurement channel the first time, a set of parameters is passed on from the currently active application. After initial setup, the parameters for the measurement channel are stored upon exiting and restored upon re-entering the channel. Thus, you can switch between applications quickly and easily.

When you activate a measurement channel for the I/Q Analyzer application, data acquisition from the input signal is started automatically with the default configuration. It can be configured in the I/Q Analyzer "Overview" dialog box, which is displayed when you select the "Overview" softkey from any menu.



The main configuration settings and dialog boxes are also available via the "I/Q Analyzer" menu which is displayed when you press the [MEAS CONFIG] key.

The remote commands required to perform these tasks are described in [Section 8.6, "Configuring I/Q analyzer measurements"](#), on page 114.



Importing and Exporting I/Q Data

The I/Q data to be evaluated in the I/Q Analyzer application can not only be captured by the I/Q Analyzer itself, it can also be imported to the R&S FSWP, provided it has the correct format. Furthermore, the captured I/Q data from the I/Q Analyzer can be exported for further analysis in external applications.

For details see [Section 4.4, "I/Q data import and export"](#), on page 31.

- [Configuration overview](#).....40
- [Import/export functions](#).....42
- [Configuring data inputs and outputs](#)..... 47
- [Configuring the amplitude](#)..... 53
- [Configuring frequency characteristics](#)..... 58
- [Configuring triggered measurements](#).....60
- [Data acquisition and bandwidth settings](#)..... 64
- [Display configuration](#).....72
- [Adjusting settings automatically](#)..... 73

5.1 Configuration overview



Throughout the measurement channel configuration, an overview of the most important currently defined settings is provided in the "Overview". The "Overview" is displayed when you select the "Overview" icon, which is available at the bottom of all softkey menus.

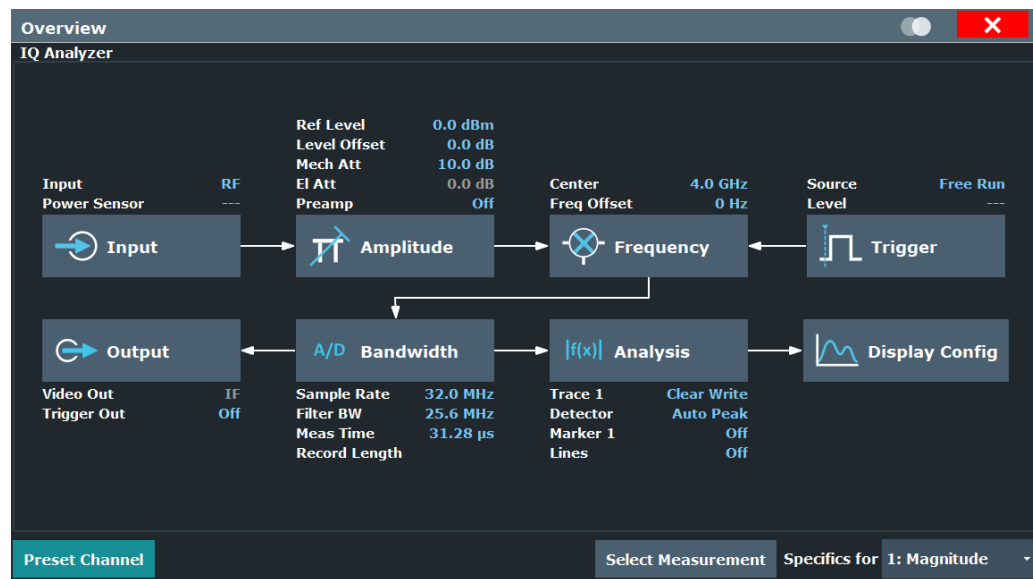

In addition to the main measurement settings, the "Overview" provides quick access to the main settings dialog boxes. The individual configuration steps are displayed in the order of the data flow. Thus, you can easily configure an entire measurement channel from input over processing to output and analysis by stepping through the dialog boxes as indicated in the "Overview".



The Overview varies depending on the application; for detailed descriptions see the corresponding application User Manual.

The "Overview" for the I/Q Analyzer Master provides quick access to the following configuration dialog boxes (listed in the recommended order of processing):

1. Configuring the input
See [Section 5.3.1, "Inputs"](#), on page 47
2. Configuring level characteristics
See [Section 5.4, "Configuring the amplitude"](#), on page 53
3. Configuring Frequency Characteristics
See [Section 5.5, "Configuring frequency characteristics"](#), on page 58
4. Configuring triggered and gated measurements
See [Section 5.6, "Configuring triggered measurements"](#), on page 60
5. Configuring the output
See [Section 5.3.2, "Outputs"](#), on page 50
6. Configuring the bandwidth
See [Section 5.7, "Data acquisition and bandwidth settings"](#), on page 64
7. Analyzing results
See the User Manual of the R&S FSWP
8. Configuring the display

See [Section 5.8, "Display configuration"](#), on page 72

To configure settings

- ▶ Select any button in the "Overview" to open the corresponding dialog box. Select a setting in the channel bar (at the top of the measurement channel tab) to change a specific setting.

For step-by-step instructions on configuring I/Q Analyzer measurements, see [Section 7.1, "How to perform measurements in the I/Q Analyzer application"](#), on page 79.

Preset Channel	42
Specific Settings for	42

Preset Channel

Select "Preset Channel" in the lower left-hand corner of the "Overview" to restore all measurement settings *in the current channel* to their default values.

Note: Do not confuse "Preset Channel" with the [Preset] key, which restores the entire instrument to its default values and thus closes *all channels* on the R&S FSWP (except for the default channel)!

Remote command:

[SYSTem:PRESet:CHANnel\[:EXEC\]](#) on page 93

Specific Settings for

The channel can contain several windows for different results. Thus, the settings indicated in the "Overview" and configured in the dialog boxes vary depending on the selected window.

Select an active window from the "Specific Settings for" selection list that is displayed in the "Overview" and in all window-specific configuration dialog boxes.

The "Overview" and dialog boxes are updated to indicate the settings for the selected window.

5.2 Import/export functions



Access: "Save"/ "Open" icon in the toolbar > "Import" / "Export"



The R&S FSWP provides various evaluation methods for the results of the performed measurements. However, you may want to evaluate the data with further, external applications. In this case, you can export the measurement data to a standard format file (ASCII or XML). Some of the data stored in these formats can also be re-imported to the R&S FSWP for further evaluation later, for example in other applications.

The following data types can be exported (depending on the application):

- Trace data
- Table results, such as result summaries, marker peak lists etc.
- I/Q data (in applications that process I/Q data)

The following data types can be imported (depending on the application):

- I/Q data (in applications that process I/Q data)



I/Q data can only be imported and exported in applications that process I/Q data, such as the I/Q analyzer or other optional applications.

See the corresponding user manuals for those applications for details.



These functions are only available if no measurement is running.

In particular, if **Continuous Sweep / Run Cont** is active, the import/export functions are not available.

Import.....	43
L I/Q Import.....	43
L File Explorer.....	43
Export.....	44
L Export Trace to ASCII File.....	44
L File Type.....	45
L Decimal Separator.....	45
L Column Separator.....	45
L File Explorer.....	45
L Export Configuration.....	45
L I/Q Export.....	45
L File Type.....	46
L File Explorer.....	46



Import

Access: "Save/Recall" > Import



Provides functions to import data.

I/Q Import ← Import

Opens a file selection dialog box to select an import file that contains I/Q data. This function is only available in single sweep mode and only in applications that process I/Q data, such as the I/Q Analyzer or optional applications.

Input from I/Q data files is imported as it was stored, including any correction factors, for example from transducers or SnP files. Any currently configured correction factors at the time of import, however, are not applied.

I/Q import is not available in MSRA mode.

Remote command:

MMEMory:LOAD:IQ:STATe on page 157

File Explorer ← I/Q Import ← Import

Opens the Microsoft Windows File Explorer.

Remote command:

not supported

**Export**

Access: "Save/Recall" > Export



Opens a submenu to configure data export.

Export Trace to ASCII File ← Export

Saves the selected trace or all traces in the currently active result display to the specified file and directory in the selected ASCII format.

"File Explorer": Instead of using the file manager of the R&S FSWP firmware, you can also use the Microsoft Windows File Explorer to manage files.

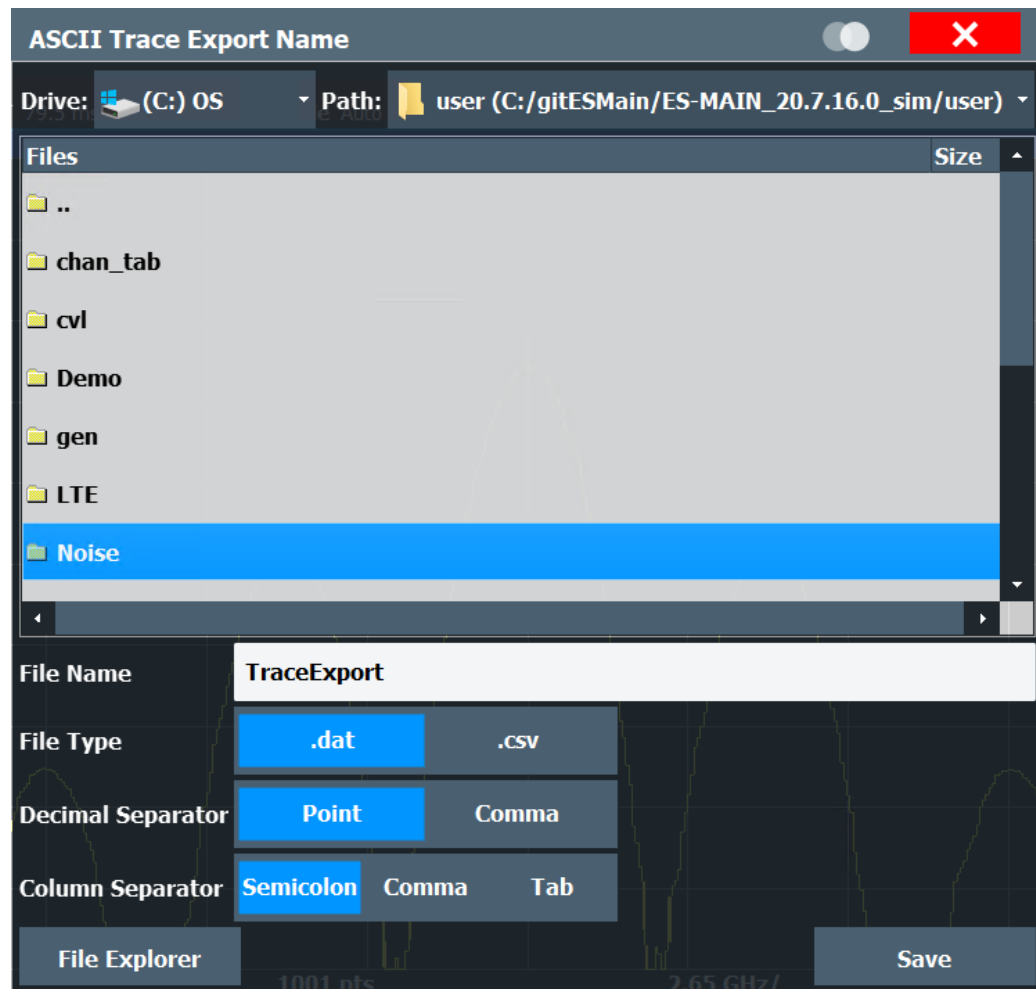

Note: Secure user mode.

In secure user mode, settings that are stored on the instrument are stored to volatile memory, which is restricted to 256 MB. Thus, a "memory limit reached" error can occur although the hard disk indicates that storage space is still available.

To store data permanently, select an external storage location such as a USB memory device.

For details, see "Protecting Data Using the Secure User Mode" in the "Data Management" section of the R&S FSWP base unit user manual.

Remote command:

[MMEMory:STORE<n>:TRACe](#) on page 108

File Type ← Export Trace to ASCII File ← Export

Determines the format of the ASCII file to be imported or exported.

Depending on the external program in which the data file was created or is evaluated, a comma-separated list (CSV) or a plain data format (DAT) file is required.

Remote command:

[FORMat:DEXPort:FORMat](#) on page 108

Decimal Separator ← Export Trace to ASCII File ← Export

Defines the decimal separator for floating-point numerals for the data export/import files. Evaluation programs require different separators in different languages.

Remote command:

[FORMat:DEXPort:DSEParator](#) on page 107

Column Separator ← Export Trace to ASCII File ← Export

Selects the character that separates columns in the exported ASCII file. The character can be either a semicolon, a comma or a tabulator (tab).

Example for semicolon:

```
Type;FSWP26;Version;1.00;Date;01.Jan 3000;
```

Example for comma:

```
Type,FSWP26,
Version,1.00,
Date,01.Jan 3000,
```

Example for tabulator (tab after the last column is not visible):

```
Type      FSWP26
Version   1.00
Date      01.Jan 3000
```

The selected column separator setting remains the same, even after a preset.

Remote command:

[FORMat:DEXPort:CSEParator](#) on page 108

File Explorer ← Export Trace to ASCII File ← Export

Opens the Microsoft Windows File Explorer.

Remote command:

not supported

Export Configuration ← Export

Opens the "Traces" dialog box to configure the trace and data export settings.

I/Q Export ← Export

Opens a file selection dialog box to define an export filename to which the I/Q data is stored. This function is only available in single sweep mode.

It is not available in the Spectrum application, only in applications that process I/Q data, such as the I/Q Analyzer or optional applications.

For details, see the description in the R&S FSWP I/Q Analyzer User Manual ("Importing and Exporting I/Q Data").

Note: Storing large amounts of I/Q data (several Gigabytes) can exceed the available (internal) storage space on the R&S FSWP. In this case, it can be necessary to use an external storage medium.

Note: Secure user mode.

In secure user mode, settings that are stored on the instrument are stored to volatile memory, which is restricted to 256 MB. Thus, a "memory limit reached" error can occur although the hard disk indicates that storage space is still available.

To store data permanently, select an external storage location such as a USB memory device.

For details, see "Protecting Data Using the Secure User Mode" in the "Data Management" section of the R&S FSWP base unit user manual.

Remote command:

[MMEMory:STORe<n>:IQ:STATe](#) on page 158

[MMEMory:STORe<n>:IQ:COMMeNt](#) on page 158

File Type ← I/Q Export ← Export

The I/Q data file can be stored in one of the following supported formats:

- .iq.tar
- .iqw
- .csv
- .mat
- .aid

Note: Not all applications support all formats.

For details on formats, see [Section A.3, "Reference: supported I/Q file formats"](#), on page 165.

Remote command:

The file type is determined by the file extension of the file name parameter. If no file extension is provided, the file type is assumed to be .iq.tar. For .mat files, Matlab® v4 is assumed.

File Explorer ← I/Q Export ← Export

Opens the Microsoft Windows File Explorer.

Remote command:

not supported

5.3 Configuring data inputs and outputs

The R&S FSWP can analyze signals from different input sources and provide various types of output (such as video or trigger signals).

- [Inputs](#)..... 47
- [Outputs](#).....50

5.3.1 Inputs

The I/Q Analyzer supports several input sources.

- [RF input](#).....47
- [Power sensors](#)..... 49
- [External generators](#).....49
- [Probes](#).....49
- [External mixers](#)..... 49
- [Settings for input from I/Q data files](#).....49

5.3.1.1 RF input

Access: "Overview" > "Input/Frontend" > "Input Source" > "Radio Frequency"

The remote commands required to configure inputs are described in [Section 8.6.3, "Configuring level characteristics"](#), on page 120, [Section 8.6.4, "Configuring the attenuator"](#), on page 122 and [Section 8.6.5, "Configuring the preamplifier"](#), on page 123.

Radio Frequency State	47
Input Coupling	47
Impedance	48
High Pass Filter 1 to 3 GHz	48
YIG-Preselector	48

Radio Frequency State

Activates input from the "RF Input" connector.

Remote command:

`INPut:SElect` on page 118

Input Coupling

The RF input of the R&S FSWP can be coupled by alternating current (AC) or direct current (DC).

AC coupling blocks any DC voltage from the input signal. AC coupling is activated by default to prevent damage to the instrument. Very low frequencies in the input signal can be distorted.

However, some specifications require DC coupling. In this case, you must protect the instrument from damaging DC input voltages manually. For details, refer to the specifications document.

Remote command:

[INPut:COUPling](#) on page 115

Impedance

The R&S FSWP has an internal impedance of 50 Ω . However, some applications use other impedance values. To match the impedance of an external application to the impedance of the R&S FSWP, an *impedance matching pad* can be inserted at the input. If the type and impedance value of the used matching pad is known to the R&S FSWP, it can convert the measured units accordingly so that the results are calculated correctly.

The impedance conversion does not affect the level of the output signals (such as IF, video, demod, digital I/Q output).

"50 Ω "	(Default:) no conversion takes place
"75 Ω "	The 50 Ω input impedance is transformed to a higher impedance using a 75 Ω adapter of the selected "Pad Type": "Series-R" (default) or "MLP" (Minimum Loss Pad)
"User"	The 50 Ω input impedance is transformed to a user-defined impedance value according to the selected "Pad Type": "Series-R" (default) or "MLP" (Minimum Loss Pad)

Remote command:

[INPut:IMPedance](#) on page 117

[INPut:IMPedance:PTYPe](#) on page 117

High Pass Filter 1 to 3 GHz

Activates an additional internal highpass filter for RF input signals from 1 GHz to 3 GHz. This filter is used to remove the harmonics of the analyzer to measure the harmonics for a DUT, for example.

This function requires an additional hardware option.

Note: For RF input signals outside the specified range, the high-pass filter has no effect. For signals with a frequency of approximately 4 GHz upwards, the harmonics are suppressed sufficiently by the YIG-preselector, if available.)

Remote command:

[INPut:FILTer:HPASs\[:STATe\]](#) on page 116

YIG-Preselector

Enables or disables the YIG-preselector.

This setting requires an additional option on the R&S FSWP.

An internal YIG-preselector at the input of the R&S FSWP ensures that image frequencies are rejected. However, image rejection is only possible for a restricted bandwidth. To use the maximum bandwidth for signal analysis you can disable the YIG-preselector at the input of the R&S FSWP, which can lead to image-frequency display.

Note: Note that the YIG-preselector is active only on frequencies greater than 8 GHz. Therefore, switching the YIG-preselector on or off has no effect if the frequency is below that value.

Note:

For the following measurements, the YIG-"Preselector" is off by default (if available).

- VSA

Remote command:

`INPut:FILTer:YIG[:STATe]` on page 117

5.3.1.2 Power sensors

Access: "Overview" > "Input" > "Power Sensors"

The functionality to use power sensors is the same as in the optional spectrum application.

For a comprehensive description, refer to the user manual of the optional R&S FSWP spectrum application.

5.3.1.3 External generators

Access: "Overview" > "Input" > "External Generator"

Controlling external generators is available with the optional external generator control. The functionality is the same as in the optional spectrum application.

For a comprehensive description, refer to the user manual of the optional R&S FSWP spectrum application.

5.3.1.4 Probes

Access: "Overview" > "Input" > "Probes"

The functionality to use probes (via the RF input) is the same as in the optional spectrum application.

For a comprehensive description, refer to the user manual of the optional R&S FSWP spectrum application.

5.3.1.5 External mixers

Access: "Overview" > "Input" > "Input Source" > "External Mixer"

Input through external mixers is available with the optional external mixer control hardware.

The features are the same as in the phase noise application. For a comprehensive description, refer to the R&S FSWP user manual.

5.3.1.6 Settings for input from I/Q data files

Access: "Overview" > "Input/Frontend" > "Input Source" > "I/Q File"

Or: [INPUT/OUTPUT] > "Input Source Config" > "Input Source" > "I/Q File"

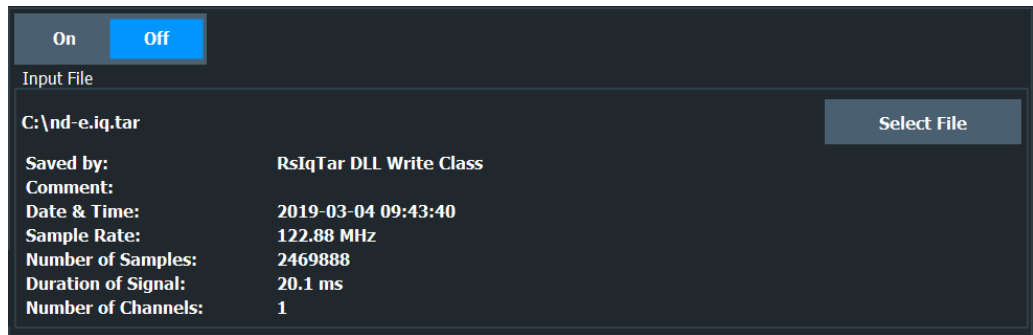

For details, see [Section 4.2, "Basics on input from I/Q data files"](#), on page 29.

[I/Q Input File State](#)..... 50
[Select I/Q data file](#)..... 50

I/Q Input File State

Enables input from the selected I/Q input file.

If enabled, the application performs measurements on the data from this file. Thus, most measurement settings related to data acquisition (attenuation, center frequency, measurement bandwidth, sample rate) cannot be changed. The measurement time can only be decreased to perform measurements on an extract of the available data only.

Note: Even when the file input is disabled, the input file remains selected and can be enabled again quickly by changing the state.

Remote command:

[INPut:SElect](#) on page 118

Select I/Q data file

Opens a file selection dialog box to select an input file that contains I/Q data.

The I/Q data must have a specific format (.iq.tar) as described in [Section A.3.1, "I/Q data file format \(iq-tar\)"](#), on page 166.

The default storage location for I/Q data files is C:\R_S\INSTR\USER.

Remote command:

[INPut:FILE:PATH](#) on page 115

5.3.2 Outputs

Access: "Overview" > "Output"

The output supported by the I/Q Analyzer are similar to those in the Phase Noise Spectrum applications.

For a comprehensive description on how to configure the DC Power sources and the Signal Source, refer to the documentation of the R&S FSWP.

[Noise Source Control](#)..... 51
[Trigger 1/2](#)..... 51
 L [Output Type](#)..... 52

- L Level..... 52
- L Pulse Length.....52
- L Send Trigger..... 52

Noise Source Control

Enables or disables the 28 V voltage supply for an external noise source connected to the "Noise source control / Power sensor") connector. By switching the supply voltage for an external noise source on or off in the firmware, you can enable or disable the device as required.

External noise sources are useful when you are measuring power levels that fall below the noise floor of the R&S FSWP itself, for example when measuring the noise level of an amplifier.

In this case, you can first connect an external noise source (whose noise power level is known in advance) to the R&S FSWP and measure the total noise power. From this value, you can determine the noise power of the R&S FSWP. Then when you measure the power level of the actual DUT, you can deduct the known noise level from the total power to obtain the power level of the DUT.

Remote command:

[DIAGnostic:SERvice:NSource](#) on page 119

Trigger 1/2

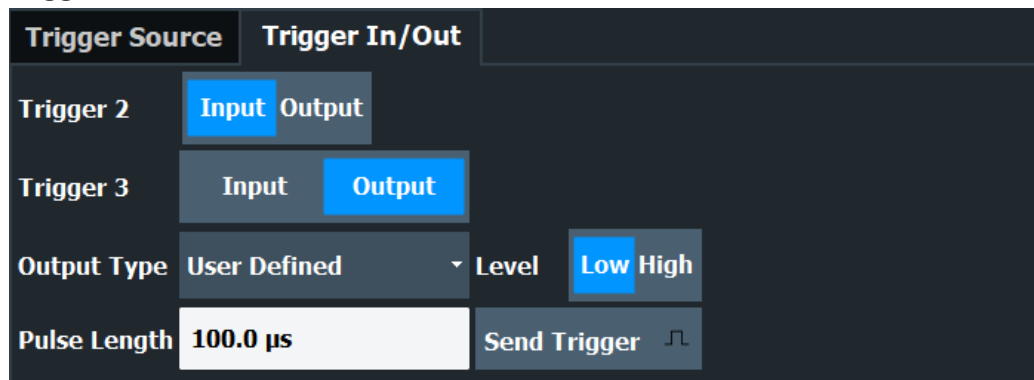

The trigger input and output functionality depends on how the variable "Trigger Input/Output" connectors are used.

Note: Providing trigger signals as output is described in detail in the R&S FSWP base unit user manual.

- "Trigger 1" "Trigger 1": "Trigger Input/Output" connector on the front panel
- "Trigger 2" Defines the usage of the variable "Trigger Input/Output" connector on the rear panel.
- "Input" The signal at the connector is used as an external trigger source by the R&S FSWP. Trigger input parameters are available in the "Trigger" dialog box.
- "Output" The R&S FSWP sends a trigger signal to the output connector to be used by connected devices. Further trigger parameters are available for the connector.

Remote command:

[OUTPut:TRIGger<tp>:DIRection](#) on page 133

Output Type ← Trigger 1/2

Type of signal to be sent to the output

- | | |
|--------------------|---|
| "Device Triggered" | (Default) Sends a trigger when the R&S FSWP triggers. |
| "Trigger Armed" | Sends a (high level) trigger when the R&S FSWP is in "Ready for trigger" state.
This state is indicated by a status bit in the <code>STATUS:OPERation</code> register (bit 5), as well as by a low-level signal at the "AUX" port (pin 9). |
| "User Defined" | Sends a trigger when you select "Send Trigger".
In this case, further parameters are available for the output signal. |

Remote command:

[OUTPut:TRIGger<tp>:OTYPe](#) on page 134

Level ← Output Type ← Trigger 1/2

Defines whether a high (1) or low (0) constant signal is sent to the trigger output connector (for "Output Type": "User Defined").

The trigger pulse level is always opposite to the constant signal level defined here. For example, for "Level" = "High", a constant high signal is output to the connector until you select the [Send Trigger](#) function. Then, a low pulse is provided.

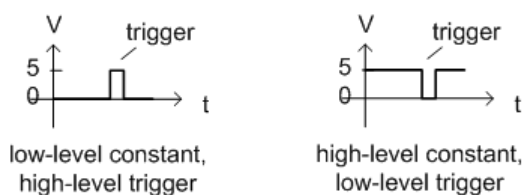

Remote command:

[OUTPut:TRIGger<tp>:LEVEl](#) on page 133

Pulse Length ← Output Type ← Trigger 1/2

Defines the duration of the pulse (pulse width) sent as a trigger to the output connector.

Remote command:

[OUTPut:TRIGger<tp>:PULSe:LENGth](#) on page 135

Send Trigger ← Output Type ← Trigger 1/2

Sends a user-defined trigger to the output connector immediately.

Note that the trigger pulse level is always opposite to the constant signal level defined by the output [Level](#) setting. For example, for "Level" = "High", a constant high signal is output to the connector until you select the "Send Trigger" function. Then, a low pulse is sent.

Which pulse level is sent is indicated by a graphic on the button.

Remote command:

[OUTPut:TRIGger<tp>:PULSe:IMMediate](#) on page 134

5.4 Configuring the amplitude

The amplitude is configured in the "Amplitude" dialog box. Amplitude settings are similar to those of the Spectrum application, except for a few functions

- [Configuring level characteristics](#)..... 53
- [Scaling the level axis](#).....56

5.4.1 Configuring level characteristics

Access: "Overview" > "Amplitude" > "Amplitude"



The electronic attenuator and its settings are not supported by the R&S FSWP.

Functions to configure amplitude characteristics described elsewhere:

- ["Input Coupling"](#) on page 47
- ["Impedance"](#) on page 48
- Scaling settings are described in [Section 5.4.2, "Scaling the level axis"](#), on page 56.

The remote commands required to configure amplitude characteristics are described in [Section 8.6.3, "Configuring level characteristics"](#), on page 120, [Section 8.6.4, "Config-](#)

uring the attenuator", on page 122 and Section 8.6.5, "Configuring the preamplifier", on page 123.

Reference Level.....	54
L Shifting the Display (Offset).....	54
L Unit.....	54
L Setting the Reference Level Automatically (Auto Level).....	55
Attenuation Mode / Value.....	55
Optimization.....	55
Preamplifier.....	56
Noise Cancellation.....	56

Reference Level

Defines the expected maximum reference level. Signal levels above this value are possibly not measured correctly. Signals above the reference level are indicated by an "IF Overload" or "OVLd" status display.

The reference level can also be used to scale power diagrams; the reference level is then used for the calculation of the maximum on the y-axis.

Since the hardware of the R&S FSWP is adapted according to this value, it is recommended that you set the reference level close above the expected maximum signal level. Thus you ensure an optimal measurement (no compression, good signal-to-noise ratio).

Note that for input from the External Mixer (R&S FSWP-B21) the maximum reference level also depends on the conversion loss; see the R&S FSWP base unit user manual for details.

Remote command:

```
DISPlay[:WINDow<n>][:SUBWindow<w>]:TRACe<t>:Y[:SCALE]:RLEVel
```

on page 121

Shifting the Display (Offset) ← Reference Level

Defines an arithmetic level offset. This offset is added to the measured level. In some result displays, the scaling of the y-axis is changed accordingly.

Define an offset if the signal is attenuated or amplified before it is fed into the R&S FSWP so the application shows correct power results. All displayed power level results are shifted by this value.

The setting range is ± 200 dB in 0.01 dB steps.

Note, however, that the *internal* reference level (used to adjust the hardware settings to the expected signal) ignores any "Reference Level Offset". Thus, it is important to keep in mind the actual power level the R&S FSWP must handle. Do not rely on the displayed reference level (internal reference level = displayed reference level - offset).

Remote command:

```
DISPlay[:WINDow<n>][:SUBWindow<w>]:TRACe<t>:Y[:SCALE]:RLEVel:OFFSet
```

on page 121

Unit ← Reference Level

The R&S FSWP measures the signal voltage at the RF input.

In the default state, the level is displayed at a power level of 1 mW (= dBm). Via the known input impedance (50 Ω or 75 Ω, see "[Impedance](#)" on page 48), conversion to other units is possible.

Remote command:

[INPut:IMPedance](#) on page 117

[CALCulate<n>:UNIT:POWer](#) on page 120

Setting the Reference Level Automatically (Auto Level) ← Reference Level

Automatically determines a reference level which ensures that no overload occurs at the R&S FSWP for the current input data. At the same time, the internal attenuators are adjusted. As a result, the signal-to-noise ratio is optimized, while signal compression and clipping are minimized.

To determine the required reference level, a level measurement is performed on the R&S FSWP.

If necessary, you can optimize the reference level further. Decrease the attenuation level manually to the lowest possible value before an overload occurs, then decrease the reference level in the same way.

You can change the measurement time for the level measurement if necessary (see "[\(Meas Time Manual\)](#)" on page 74).

Remote command:

[\[SENSe:\]ADJust:LEVel](#) on page 148

Attenuation Mode / Value

Defines the attenuation applied to the RF input of the R&S FSWP.

The RF attenuation can be set automatically as a function of the selected reference level (Auto mode). Automatic attenuation ensures that no overload occurs at the RF Input connector for the current reference level. It is the default setting.

In "Manual" mode, you can set the RF attenuation in 1 dB steps (down to 0 dB). Other entries are rounded to the next integer value. The range is specified in the specifications document. If the defined reference level cannot be set for the defined RF attenuation, the reference level is adjusted accordingly and the warning "limit reached" is displayed.

NOTICE! Risk of hardware damage due to high power levels. When decreasing the attenuation manually, ensure that the power level does not exceed the maximum level allowed at the RF input, as an overload can lead to hardware damage.

Remote command:

[INPut:ATTenuation](#) on page 122

[INPut:ATTenuation:AUTO](#) on page 122

Optimization

Selects the priority for signal processing *after* the RF attenuation has been applied.

"Low distortion"

(Default:) Optimized for low distortion by avoiding intermodulation

"Low noise"

Optimized for high sensitivity and low noise levels

If this setting is selected, "Low noise" is indicated in the channel information bar.

Remote command:

[INPut:ATTenuation:AUTO:MODE](#) on page 123

Preamplifier

If the (optional) internal preamplifier hardware is installed on the R&S FSWP, a preamplifier can be activated for the RF input signal.

You can use a preamplifier to analyze signals from DUTs with low output power.

The preamplifier amplifies the signal by 15 dB or 30 dB and is only available for frequencies above 8 GHz for the phase noise measurement. In the spectrum analyzer, the preamplifier is available for the whole frequency range.

Note that the preamplifier is located before the point where the signal is split into two paths. Consequently, the influence of cross-correlation is limited in this configuration.

Note: The preamplifier is useful for signals with power levels of -20 dBm or less, particularly when large offsets are important.

"Off" Deactivates the preamplifier.

"On" The RF input signal is amplified.

Remote command:

[INPut:GAIN:STATe](#) on page 123

[INPut:GAIN\[:VALue\]](#) on page 124

Noise Cancellation

The R&S FSWP can correct the results by removing the inherent noise of the analyzer, which increases the dynamic range.

In this case, a reference measurement of the inherent noise of the analyzer is carried out. The measured noise power is then subtracted from the power in the channel that is being analyzed (first active trace only).

The inherent noise of the instrument depends on the selected center frequency, resolution bandwidth and level setting. Therefore, the correction function is disabled whenever one of these parameters is changed. A disable message is displayed on the screen. To enable the correction function after changing one of these settings, activate it again. A new reference measurement is carried out.

Noise cancellation is also available in zero span.

Currently, noise cancellation is only available for the following trace detectors:

- RMS
- Average
- Sample
- Positive peak

Remote command:

[\[SENSe:\]POWer:NCORrection](#) on page 122

5.4.2 Scaling the level axis

Access: "Overview" > "Amplitude" > "Scale"

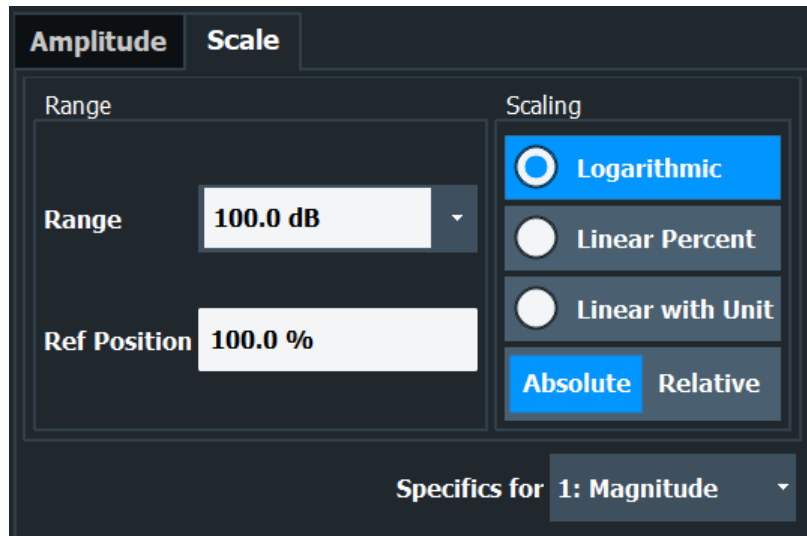

The remote commands required to scale the y-axis are described in [Section 8.6.6, "Scaling the Y-Axis"](#), on page 124.

Range.....	57
Ref Level Position.....	57
Auto Scale Once.....	57
Scaling.....	58
Y-Axis Max.....	58

Range

Defines the displayed y-axis range in dB.

The default value is 100 dB.

Remote command:

`DISPlay[:WINDow<n>][:SUBWindow<w>]:TRACe<t>:Y[:SCALe]` on page 124

Ref Level Position

Defines the reference level position, i.e. the position of the maximum AD converter value on the level axis in %.

0 % corresponds to the lower and 100 % to the upper limit of the diagram.

Values from -120 % to +280 % are available.

Larger values are useful for small scales, such as a power range of 10 dB or 20 dB, and low signal levels, for example 60 dB below the reference level. In this case, large reference level position values allow you to see the trace again.

Remote command:

`DISPlay[:WINDow<n>][:SUBWindow<w>]:TRACe<t>:Y[:SCALe]:RPOSition` on page 125

Auto Scale Once

Automatically determines the optimal range and reference level position to be displayed for the current measurement settings.

The display is only set once; it is not adapted further if the measurement settings are changed again.

Remote command:

`DISPlay[:WINDow<n>][:SUBWindow<w>]:TRACe<t>:Y[:SCALe]:AUTO ONCE`
on page 125

Scaling

Defines the scaling method for the y-axis.

"Logarithmic"	Logarithmic scaling (only available for logarithmic units - dB..., and A, V, Watt)
"Linear with Unit"	Linear scaling in the unit of the measured signal
"Linear Percent"	Linear scaling in percentages from 0 to 100
"Absolute"	The labeling of the level lines refers to the absolute value of the reference level (not available for "Linear Percent")
"Relative"	The scaling is in dB, relative to the reference level (only available for logarithmic units - dB...). The upper line of the grid (reference level) is always at 0 dB.

Remote command:

`DISPlay[:WINDow<n>][:SUBWindow<w>]:TRACe<t>:Y:SPACing` on page 126
`DISPlay[:WINDow<n>][:SUBWindow<w>]:TRACe<t>:Y[:SCALe]:MODE`
on page 125

Y-Axis Max

Defines the maximum value of the y-axis in the currently selected diagram in either direction (in Volts). Thus, the y-axis scale starts at $-<Y\text{-Axis Max}>$ and ends at $+<Y\text{-Axis Max}>$.

The maximum y-axis value depends on the current reference level. If the reference level is changed, the "Y-Axis Max" value is automatically set to the new reference level (in V).

This command is only available if the evaluation mode for the I/Q Analyzer is set to "I/Q-Vector" or "Real/Imag (I/Q)".

Remote command:

`DISPlay[:WINDow<n>][:SUBWindow<w>]:TRACe<t>:Y[:SCALe]` on page 124

5.5 Configuring frequency characteristics

Access: "Overview" > "Frequency"

Frequency	
Center	13.25 GHz
Center Frequency Stepsize	
Stepsize	Manual Value 1.0 MHz
Frequency Offset	
Value	0.0 Hz

The remote commands required to configure the frequency are described in [Section 8.6.7, "Configuring the frequency"](#), on page 126.

Center Frequency	59
Center Frequency Stepsize	59
Frequency Offset	59

Center Frequency

Defines the center frequency of the signal in Hertz.

The allowed range of values for the center frequency depends on the frequency span.

$$\text{span} > 0: \text{span}_{\min}/2 \leq f_{\text{center}} \leq f_{\text{max}} - \text{span}_{\min}/2$$

f_{max} and span_{\min} depend on the instrument and are specified in the specifications document.

Remote command:

[\[SENSe:\] FREQuency:CENTer](#) on page 127

Center Frequency Stepsize

Defines the step size by which the center frequency is increased or decreased using the arrow keys.

When you use the rotary knob the center frequency changes in steps of only 1/10 of the span.

The step size can be coupled to another value or it can be manually set to a fixed value.

"= Center" Sets the step size to the value of the center frequency. The used value is indicated in the "Value" field.

"Manual" Defines a fixed step size for the center frequency. Enter the step size in the "Value" field.

Remote command:

[\[SENSe:\] FREQuency:CENTer:STEP](#) on page 127

Frequency Offset

Shifts the displayed frequency range along the x-axis by the defined offset.

This parameter has no effect on the instrument's hardware, on the captured data, or on data processing. It is simply a manipulation of the final results in which absolute frequency values are displayed. Thus, the x-axis of a spectrum display is shifted by a constant offset if it shows absolute frequencies. However, if it shows frequencies relative to the signal's center frequency, it is not shifted.

A frequency offset can be used to correct the display of a signal that is slightly distorted by the measurement setup, for example.

The allowed values range from -1 THz to 1 THz. The default setting is 0 Hz.

Note: In MSRA mode, this function is only available for the MSRA primary.

Remote command:

[SENSe:] FREQuency: OFFSet on page 128

5.6 Configuring triggered measurements

Access (trigger source): "Overview" > "Trigger / Gate" > "Trigger Source"

Access (trigger connectors): "Overview" > "Trigger / Gate" > "Trigger In / Out"

Trigger settings determine when the input signal is measured.

Trigger Source	Trigger In/Out	
Source	Ext Trigger 1	
Level	1.4 V	Drop-Out Time 0.0 s
Offset	0.0 s	Slope Rising Falling
Hysteresis	3.0 dB	Holdoff 0.0 s



Conventional gating as in the Spectrum application is not available for the I/Q Analyzer; however, a special gating mode is available in remote control, see [Section 8.6.10, "Configuring gated measurements"](#), on page 135.

For step-by-step instructions on configuring triggered measurements, see the user manual of the spectrum application.

Functions to configure trigger output described elsewhere:

- ["Trigger 1/2"](#) on page 51

The remote commands required to configure triggered measurements are described in [Section 8.6.8, "Configuring trigger"](#), on page 128.

Trigger Source.....	61
└ Free Run.....	61
└ Ext. Trigger 1/2.....	61

L IF Power.....	62
L I/Q Power.....	62
L RF Power.....	62
L Time.....	63
Trigger Level.....	63
Repetition Interval.....	63
Trigger Offset.....	63
Hysteresis.....	63
Drop-Out Time.....	64
Trigger Holdoff.....	64
Slope.....	64

Trigger Source

Selects the trigger source. If a trigger source other than "Free Run" is set, "TRG" is displayed in the channel bar and the trigger source is indicated.

Remote command:

TRIGger [: SEQuence] : SOURce on page 132

Free Run ← Trigger Source

No trigger source is considered. Data acquisition is started manually or automatically and continues until stopped explicitly.

Remote command:

TRIG: SOUR IMM, see TRIGger [: SEQuence] : SOURce on page 132

Ext. Trigger 1/2 ← Trigger Source

Data acquisition starts when the TTL signal fed into the specified input connector meets or exceeds the specified trigger level.

Note: "External Trigger 1" automatically selects the trigger signal from the "Trigger Input / Output" connector on the front panel.

In the I/Q Analyzer application, only "External Trigger 1" is supported.

For details, see the "Instrument Tour" section in the R&S FSWP Getting Started manual.

"External Trigger 1"

Trigger signal from the "Trigger Input / Output" connector.
(front panel)

"External Trigger 2"

Trigger signal from the "Sync Trigger Input / Output" connector.
(rear panel)

Note: Connector must be configured for "Input" in the "Output" configuration
(See the R&S FSWP base unit user manual).

Remote command:

TRIG: SOUR EXT, TRIG: SOUR EXT2

See TRIGger [: SEQuence] : SOURce on page 132

IF Power ← Trigger Source

The R&S FSWP starts capturing data as soon as the trigger level is exceeded around the third intermediate frequency.

For frequency sweeps, the third IF represents the start frequency. The trigger threshold depends on the defined trigger level, as well as on the RF attenuation and preamplification. A reference level offset, if defined, is also considered. The trigger bandwidth at the intermediate frequency depends on the RBW and sweep type. For details on available trigger levels and trigger bandwidths, see the instrument specifications document.

For measurements on a fixed frequency (e.g. zero span or I/Q measurements), the third IF represents the center frequency.

This trigger source is only available for RF input.

The available trigger levels depend on the RF attenuation and preamplification. A reference level offset, if defined, is also considered.

For details on available trigger levels and trigger bandwidths, see the specifications document.

Remote command:

TRIG:SOUR IFP, see [TRIGger\[:SEquence\]:SOURce](#) on page 132

I/Q Power ← Trigger Source

This trigger source is only available in the I/Q Analyzer application and in applications that process I/Q data.

Triggers the measurement when the magnitude of the sampled I/Q data exceeds the trigger threshold.

The trigger bandwidth corresponds to the bandwidth setting for I/Q data acquisition.

(See "[Analysis Bandwidth](#)" on page 66).

Remote command:

TRIG:SOUR IQP, see [TRIGger\[:SEquence\]:SOURce](#) on page 132

RF Power ← Trigger Source

Defines triggering of the measurement via signals which are outside the displayed measurement range.

For this purpose, the instrument uses a level detector at the first intermediate frequency.

The input signal must be in the frequency range between 500 MHz and 8 GHz.

The resulting trigger level at the RF input depends on the RF attenuation and preamplification. For details on available trigger levels, see the instrument's specifications document.

Note: If the input signal contains frequencies outside of this range (e.g. for fullspan measurements), the measurement can be aborted. A message indicating the allowed input frequencies is displayed in the status bar.

A "Trigger Offset", "Trigger Polarity" and "Trigger Holdoff" (to improve the trigger stability) can be defined for the RF trigger, but no "Hysteresis".

Remote command:

TRIG:SOUR RFP, see [TRIGger\[:SEquence\]:SOURce](#) on page 132

Time ← Trigger Source

Triggers in a specified repetition interval.

See "[Repetition Interval](#)" on page 63.

Remote command:

TRIG:SOUR TIME, see [TRIGger\[:SEquence\]:SOURce](#) on page 132

Trigger Level

Defines the trigger level for the specified trigger source.

For details on supported trigger levels, see the instrument specifications document.

For time triggers, the repetition interval is defined. See "[Repetition Interval](#)" on page 63.

Remote command:

[TRIGger\[:SEquence\]:LEVel:IFPower](#) on page 130

[TRIGger\[:SEquence\]:LEVel:IQPower](#) on page 131

[TRIGger\[:SEquence\]:LEVel\[:EXternal<port>\]](#) on page 130

[TRIGger\[:SEquence\]:LEVel:RFPower](#) on page 131

Repetition Interval

Defines the repetition interval for a time trigger.

The shortest interval is 2 ms.

Set the repetition interval to the exact pulse period, burst length, frame length or other repetitive signal characteristic. If the required interval cannot be set with the available granularity, configure a multiple of the interval that can be set. Thus, the trigger remains synchronized to the signal.

Remote command:

[TRIGger\[:SEquence\]:TIME:RINterval](#) on page 133

Trigger Offset

Defines the time offset between the trigger event and the start of the measurement.

Offset > 0:	Start of the measurement is delayed
Offset < 0:	Measurement starts earlier (pretrigger) Only possible for zero span (e.g. I/Q Analyzer application) and gated trigger switched off Maximum allowed range limited by the measurement time: $\text{Pretrigger}_{\text{max}} = \text{measurement time}_{\text{max}}$

Tip: To determine the trigger point in the sample (for "External" or "IF Power" trigger source), use the [TRACe:IQ:TPISample?](#) command.

Remote command:

[TRIGger\[:SEquence\]:HOLDoff\[:TIME\]](#) on page 129

Hysteresis

Defines the distance in dB to the trigger level that the trigger source must exceed before a trigger event occurs. Setting a hysteresis avoids unwanted trigger events caused by noise oscillation around the trigger level.

This setting is only available for "IF Power" trigger sources. The range of the value is between 3 dB and 50 dB with a step width of 1 dB.

Remote command:

[TRIGger\[:SEquence\]:IFPower:HYSteresis](#) on page 130

Drop-Out Time

Defines the time that the input signal must stay below the trigger level before triggering again.

Remote command:

[TRIGger\[:SEquence\]:DTIME](#) on page 129

Trigger Holdoff

Defines the minimum time (in seconds) that must pass between two trigger events. Trigger events that occur during the holdoff time are ignored.

Remote command:

[TRIGger\[:SEquence\]:IFPower:HOLDoff](#) on page 129

Slope

For all trigger sources except time, you can define whether triggering occurs when the signal rises to the trigger level or falls down to it.

For gated measurements in "Edge" mode, the slope also defines whether the gate starts on a falling or rising edge.

Remote command:

[TRIGger\[:SEquence\]:SLOPe](#) on page 131

5.7 Data acquisition and bandwidth settings

Access: "Overview" > "Bandwidth"

- [Data acquisition](#).....64
- [Sweep settings](#).....70

5.7.1 Data acquisition

Access: "Overview" > "Bandwidth" > "Data Acquisition" tab

The data acquisition settings define which parts of the input signal are captured for further evaluation in the applications.

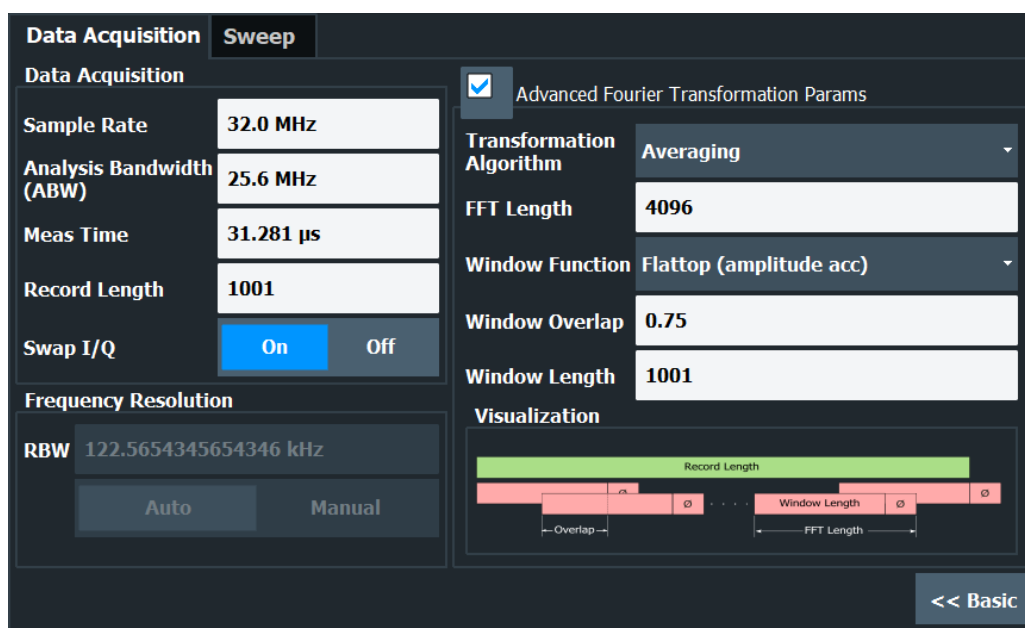

Figure 5-1: Data acquisition settings with advanced FFT parameters



MSRA operating mode

In MSRA operating mode, only the MSRA Master channel actually captures data from the input signal. The data acquisition settings for the I/Q Analyzer application in MSRA mode define the analysis interval.

For details on the MSRA operating mode see the R&S FSWP MSRA User Manual.

The remote commands required to configure the data acquisition are described in [Section 8.6.11, "Configuring data acquisition"](#), on page 137.

Sample Rate.....	65
Analysis Bandwidth.....	66
Maximum Bandwidth.....	66
200 MHz Filter.....	66
Meas Time.....	67
Record Length.....	67
Swap I/Q.....	67
RBW.....	68
Advanced FFT mode / Basic Settings.....	68
L Transformation Algorithm.....	68
L FFT Length.....	69
L Window Function.....	69
L Window Overlap.....	69
L Window Length.....	69
Capture Offset.....	70

Sample Rate

Defines the I/Q data sample rate of the R&S FSWP. This value depends on the defined [Analysis Bandwidth](#).

Note: The Spectrum Monitor is limited to a maximum sample rate of 25 MHz.

The following rule applies:

$$\text{sample rate} = \text{analysis bandwidth} / 0.8$$

For details on the dependencies see [Section 4.1.1, "Sample rate and maximum usable I/Q bandwidth for RF input"](#), on page 25.

Remote command:

[TRACe: IQ:SRATe](#) on page 143

Analysis Bandwidth

Defines the flat, usable bandwidth of the final I/Q data. This value depends on the defined [Sample Rate](#).

Note: The Spectrum Monitor is limited to a maximum analysis bandwidth of 20 MHz.

The following rule applies:

$$\text{analysis bandwidth} = 0.8 * \text{sample rate}$$

Remote command:

[TRACe: IQ:BWIDth](#) on page 141

Maximum Bandwidth

Defines the maximum bandwidth to be used by the R&S FSWP for I/Q data acquisition. Which options are available depends on which bandwidth extension options are installed.

This setting is only available if the 320 MHz bandwidth extension option is installed on the R&S FSWP. Otherwise the maximum bandwidth is determined automatically.

"Auto" (Default:) All installed bandwidth extension options are enabled. The currently available maximum bandwidth is allowed.
Note that the 320 MHz bandwidth extension may cause more spurious effects.

Note: If the 320 MHz bandwidth extension is active on the R&S FSWP, the "IF WIDE OUTPUT" connector is automatically used to provide IF output.

See the R&S FSWP getting started manual for details on the connector.

"80 MHz" Restricts the analysis bandwidth to a maximum of 80 MHz.

"160 MHz" Restricts the analysis bandwidth to a maximum of 160 MHz. The bandwidth extension option for 320 MHz is disabled.

Remote command:

[TRACe: IQ:WBANd\[:STATe\]](#) on page 145

[TRACe: IQ:WBANd:MBWidth](#) on page 144

200 MHz Filter

Activates a 200 MHz filter before the A/D converter, thus restricting the processed bandwidth to 200 MHz while using the wideband processing path in the R&S FSWP.

This is useful for signals that have a bandwidth of approximately 200 MHz (for example Doccis 3.1). In this case, the R&S FSWP can optimize signal processing for the relevant signal and filter out unwanted signal parts from adjacent channels, while taking advantage of a higher sample rate.

If you simply reduce the specified [Analysis Bandwidth](#), the sample rate, which is coupled, is also reduced.

This function is only available under the following conditions:

- One of the following options that provide a separate wideband processing path in the R&S FSWP is installed:
 - Bandwidth extension R&S FSWP-B320
- An I/Q bandwidth that requires the wideband path is used.

If the filter is active, "200 MHz" is indicated in the channel information bar.

Remote command:

[TRACe:IQ:WFILter](#) on page 145

Meas Time

Defines the I/Q acquisition time. By default, the measurement time is calculated as the number of I/Q samples ("Record Length") divided by the sample rate. If you change the measurement time, the [Record Length](#) is automatically changed, as well.

For details on the maximum number of samples see also [Section 4.1.1, "Sample rate and maximum usable I/Q bandwidth for RF input"](#), on page 25.

Remote command:

[\[SENSe:\]SWEep:TIME](#) on page 101

Record Length

Defines the number of I/Q samples to record. By default, the number of measurement points is used. The record length is calculated as the measurement time multiplied by the sample rate. If you change the record length, the [Meas Time](#) is automatically changed, as well.

Note: For the I/Q vector result display, the number of I/Q samples to record ("Record Length") must be identical to the number of trace points to be displayed ("Sweep Points"). Thus, the measurement points are not editable for this result display. If the "Record Length" is edited, the measurement points are adapted automatically.

For record lengths outside the valid range of measurement points, i.e. fewer than 101 points or more than 100001 points, the diagram does not show valid results.

Remote command:

[TRACe:IQ:RLENgth](#) on page 141

[TRACe:IQ:SET](#) on page 142

Swap I/Q

Activates or deactivates the inverted I/Q modulation. If the I and Q parts of the signal from the DUT are interchanged, the R&S FSWP can do the same to compensate for it.

On	I and Q signals are interchanged Inverted sideband, $Q+j*I$
Off	I and Q signals are not interchanged Normal sideband, $I+j*Q$

Remote command:

[\[SENSe:\]SWAPiQ](#) on page 141

RBW

Defines the resolution bandwidth for Spectrum results. The available RBW values depend on the sample rate and record length.

(See [Section 4.5.4, "Frequency resolution of FFT results - RBW"](#), on page 36).

Depending on the selected RBW mode, the value is either determined automatically or can be defined manually. As soon as you enter a value in the input field, the RBW mode is changed to "Manual".

If the "Advanced Fourier Transformation Params" option is enabled, advanced FFT mode is selected and the RBW cannot be defined directly.

Note that the RBW is correlated with the [Sample Rate](#) and [Record Length](#) (and possibly the [Window Function](#) and [Window Length](#)). Changing any one of these parameters may cause a change to one or more of the other parameters. For more information see [Section 4.5, "Basics on FFT"](#), on page 32.

- "Auto mode" (Default) The RBW is determined automatically depending on the [Sample Rate](#) and [Record Length](#).
- "Manual mode" The RBW can be defined by the user. The user-defined RBW is used and the [Window Length](#) (and possibly [Sample Rate](#)) are adapted accordingly.
- "Advanced FFT mode" This mode is used if the "Advanced Fourier Transformation Params" option is enabled. The RBW is determined by the [advanced FFT parameters](#).

Remote command:

[\[SENSe:\]IQ:BWIDth:MODE](#) on page 138

[\[SENSe:\]IQ:BWIDth:RESolution](#) on page 138

Advanced FFT mode / Basic Settings

Shows or hides the "Advanced Fourier Transformation" parameters in the "Data Acquisition" dialog box.

These parameters are only available and required for the advanced FFT mode.

Note: The advanced settings are not supported by the Spectrum Monitor.

Note that if the advanced FFT mode is used, the [RBW](#) settings are not available.

For more information see [Section 4.5.4, "Frequency resolution of FFT results - RBW"](#), on page 36.

Transformation Algorithm ← Advanced FFT mode / Basic Settings

Defines the FFT calculation method.

"Single"	One FFT is calculated for the entire record length; if the FFT Length is larger than the record length, zeros are appended to the captured data.
"Averaging"	Several overlapping FFTs are calculated for each record; the results are combined to determine the final FFT result for the record. The number of FFTs to be averaged is determined by the Window Overlap and the Window Length .

Remote command:

[\[SENSe:\] IQ:FFT:ALGORITHM](#) on page 139

FFT Length ← **Advanced FFT mode / Basic Settings**

Defines the number of frequency points determined by each FFT calculation. The more points are used, the higher the resolution in the spectrum becomes, but the longer the calculation takes.

In advanced FFT mode, the number of measurement points is set to the FFT length automatically.

Note: If you use the arrow keys or the rotary knob to change the FFT length, the value is incremented or decremented by powers of 2.

If you enter the value manually, any integer value from 3 to 524288 is available.

Remote command:

[\[SENSe:\] IQ:FFT:LENGTH](#) on page 139

Window Function ← **Advanced FFT mode / Basic Settings**

In the I/Q analyzer you can select one of several FFT window types.

The following window types are available:

- Blackman-Harris
- Flattop
- Gauss
- Rectangular
- 5-Term

Remote command:

[\[SENSe:\] IQ:FFT:WINDOW:TYPE](#) on page 140

Window Overlap ← **Advanced FFT mode / Basic Settings**

Defines the part of a single FFT window that is re-calculated by the next FFT calculation when using multiple FFT windows.

Remote command:

[\[SENSe:\] IQ:FFT:WINDOW:OVERlap](#) on page 140

Window Length ← **Advanced FFT mode / Basic Settings**

Defines the number of samples to be included in a single FFT window in averaging mode. (In single mode, the window length corresponds to the ["Record Length"](#) on page 67.)

Values from 3 to 4096 are available in "Manual" mode; in "Advanced" FFT mode, values from 3 to 524288 are available.

However, the window length may not be longer than the [FFT Length](#).

Remote command:

[SENSe:] IQ:FFT:WINDow:LENGth on page 139

Capture Offset

This setting is only available for secondary applications in **MSRA operating mode**. It has a similar effect as the trigger offset in other measurements: it defines the time offset between the capture buffer start and the start of the extracted secondary application data.

In MSRA mode, the offset must be a positive value, as the capture buffer starts at the trigger time = 0.

For details on the MSRA operating mode, see the R&S FSWP MSRA User Manual.

Remote command:

[SENSe:]MSRA:CAPTure:OFFSet on page 140

5.7.2 Sweep settings

Access: "Overview" > "Bandwidth" > "Sweep" tab

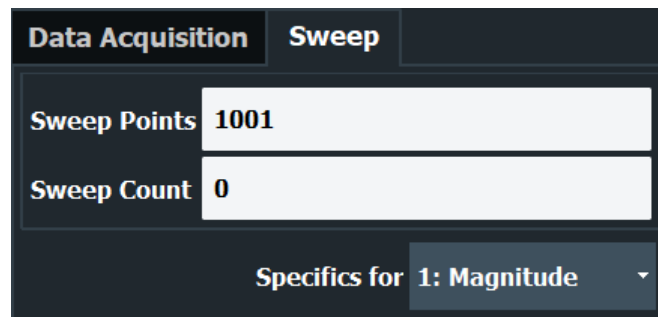

For more information on the spectrogram settings that become available when you turn on a spectrogram, refer to the R&S FSWP user manual.

The remote commands required to configure the sweep are described in [Section 8.6.11, "Configuring data acquisition"](#), on page 137.

Sweep Points.....	70
Sweep/Average Count.....	71
Continuous Sweep / Run Cont.....	71
Single Sweep / Run Single.....	71
Continue Single Sweep.....	72

Sweep Points

In the I/Q Analyzer application, a specific frequency bandwidth is swept for a specified measurement time. During this time, a defined number of samples (= "Record Length") are captured. These samples are then evaluated by the applications. Therefore, in this case the number of sweep points does not define the amount of data to be acquired, but rather the number of trace points that are evaluated and displayed in the result diagrams.

Note: As opposed to previous versions of the I/Q Analyzer, the sweep settings are now window-specific.

For some result displays, the sweep points may not be editable as they are determined automatically, or restrictions may apply. For the I/Q vector result display, the number of I/Q samples to record ("Record Length") must be identical to the number of trace points to be displayed ("Sweep Points"). Thus, the sweep points are not editable for this result display. If the "Record Length" is edited, the sweep points are adapted automatically. For record lengths outside the valid range of sweep points, i.e. less than 101 points or more than 100001 points, the diagram does not show valid results.

Using fewer than 4096 sweep points with a detector other than "Auto Peak" may lead to wrong level results. For details see ["Combining results - trace detector"](#) on page 34.

Remote command:

[\[SENSe:\] SWEep\[:WINDow<n>\]:POINTs](#) on page 101

Sweep/Average Count

Defines the number of measurements to be performed in the single sweep mode. Values from 0 to 200000 are allowed. If the values 0 or 1 are set, one measurement is performed.

The sweep count is applied to all the traces in all diagrams.

If the trace modes "Average", "Max Hold" or "Min Hold" are set, this value also determines the number of averaging or maximum search procedures.

In continuous sweep mode, if "Sweep Count" = 0 (default), averaging is performed over 10 measurements. For "Sweep Count" = 1, no averaging, maxhold or minhold operations are performed.

Remote command:

[\[SENSe:\] SWEep:COUNT](#) on page 100

[TRACe:IQ:AVERAge:COUNT](#) on page 99

Continuous Sweep / Run Cont

After triggering, starts the sweep and repeats it continuously until stopped. This is the default setting.

While the measurement is running, "Continuous Sweep" and [RUN CONT] are highlighted. The running measurement can be aborted by selecting the highlighted softkey or key again. The results are not deleted until a new measurement is started.

Note: Sequencer. If the Sequencer is active, "Continuous Sweep" only controls the sweep mode for the currently selected channel. However, the sweep mode only takes effect the next time the Sequencer activates that channel, and only for a channel-defined sequence. In this case, a channel in continuous sweep mode is swept repeatedly.

Furthermore, [RUN CONT] controls the Sequencer, not individual sweeps. [RUN CONT] starts the Sequencer in continuous mode.

Remote command:

[INITiate<n>:CONTinuous](#) on page 97

Single Sweep / Run Single

After triggering, starts the number of sweeps set in "Sweep Count". The measurement stops after the defined number of sweeps has been performed.

While the measurement is running, "Single Sweep" and [RUN SINGLE] are highlighted. The running measurement can be aborted by selecting the highlighted softkey or key again.

Note: Sequencer. If the Sequencer is active, "Single Sweep" only controls the sweep mode for the currently selected channel. However, the sweep mode only takes effect the next time the Sequencer activates that channel, and only for a channel-defined sequence. In this case, the Sequencer sweeps a channel in single sweep mode only once.

Furthermore, [RUN SINGLE] controls the Sequencer, not individual sweeps. [RUN SINGLE] starts the Sequencer in single mode.

If the Sequencer is off, only the evaluation for the currently displayed channel is updated.

For details on the Sequencer, see the R&S FSWP base unit user manual.

Remote command:

[INITiate<n>\[:IMMEDIATE\]](#) on page 98

Continue Single Sweep

After triggering, repeats the number of sweeps set in "Sweep Count", without deleting the trace of the last measurement.

While the measurement is running, "Continue Single Sweep" and [RUN SINGLE] are highlighted. The running measurement can be aborted by selecting the highlighted softkey or key again.

Remote command:

[INITiate<n>:CONMeas](#) on page 96

5.8 Display configuration

Access: "Overview" > "Display Config"

The captured signal can be displayed using various evaluation methods. All evaluation methods available for the current application are displayed in the evaluation bar in SmartGrid mode.

For a description of the available evaluation methods see [Section 3, "Measurement and result displays"](#), on page 18.



Up to 6 evaluations can be displayed in the I/Q Analyzer at any time, including several graphical diagrams, marker tables or peak lists.

The selected evaluation method not only affects the result display in a window, but also the results of the trace data query in remote control (see [TRACe<n>\[:DATA\]?](#) on page 109).

5.9 Adjusting settings automatically

Access: [AUTO SET]

Some settings can be adjusted by the R&S FSWP automatically according to the current measurement settings. To do so, a measurement is performed. You can configure this measurement.



MSRA operating mode

In MSRA operating mode, settings related to data acquisition can only be adjusted automatically for the MSRA primary, not the secondary applications.



Adjusting settings automatically during triggered measurements

When you select an auto adjust function, a measurement is performed to determine the optimal settings. If you select an auto adjust function for a triggered measurement, you are asked how the R&S FSWP should behave:

- (Default:) The measurement for adjustment waits for the next trigger
- The measurement for adjustment is performed without waiting for a trigger. The trigger source is temporarily set to "Free Run". After the measurement is completed, the original trigger source is restored. The trigger level is adjusted as follows for "IF Power" and "RF Power" triggers:
Trigger level = Reference level - 15 dB

Remote command:

[SENSe:]ADJust:CONFigure:TRIGger on page 147

Adjusting all Determinable Settings Automatically (Auto All).....	73
Adjusting the Center Frequency Automatically (Auto Frequency).....	73
Setting the Reference Level Automatically (Auto Level).....	74
Resetting the Automatic Measurement Time (Meas Time Auto).....	74
(Meas Time Manual).....	74
Upper Level Hysteresis.....	74
Lower Level Hysteresis.....	75

Adjusting all Determinable Settings Automatically (Auto All)

Activates all automatic adjustment functions for the current measurement settings, including:

- [Auto Frequency](#)
- [Auto Level](#)

Note: MSRA operating modes. In MSRA operating mode, this function is only available for the MSRA primary, not the secondary applications.

Remote command:

[SENSe:]ADJust:ALL on page 146

Adjusting the Center Frequency Automatically (Auto Frequency)

The R&S FSWP adjusts the center frequency automatically.

The optimum center frequency is the frequency with the highest S/N ratio in the frequency span. As this function uses the signal counter, it is intended for use with sinusoidal signals.

Remote command:

[\[SENSe:\]ADJust:FREQuency](#) on page 148

Setting the Reference Level Automatically (Auto Level)

Automatically determines a reference level which ensures that no overload occurs at the R&S FSWP for the current input data. At the same time, the internal attenuators are adjusted. As a result, the signal-to-noise ratio is optimized, while signal compression and clipping are minimized.

To determine the required reference level, a level measurement is performed on the R&S FSWP.

If necessary, you can optimize the reference level further. Decrease the attenuation level manually to the lowest possible value before an overload occurs, then decrease the reference level in the same way.

You can change the measurement time for the level measurement if necessary (see "[\(Meas Time Manual\)](#)" on page 74).

Remote command:

[\[SENSe:\]ADJust:LEVel](#) on page 148

Resetting the Automatic Measurement Time (Meas Time Auto)

Resets the measurement duration for automatic settings to the default value.

Remote command:

[\[SENSe:\]ADJust:CONFigure:LEVel:DURation:MODE](#) on page 146

(Meas Time Manual)

This function allows you to change the measurement duration for automatic setting adjustments. Enter the value in seconds.

Note: The maximum measurement duration depends on the currently selected measurement and the installed (optional) hardware. Thus, the measurement duration actually used to determine the automatic settings can be shorter than the value you define here.

Remote command:

[\[SENSe:\]ADJust:CONFigure:LEVel:DURation:MODE](#) on page 146

[\[SENSe:\]ADJust:CONFigure:LEVel:DURation](#) on page 146

Upper Level Hysteresis

When the reference level is adjusted automatically using the [Auto Level](#) function, the internal attenuators and the preamplifier are also adjusted. To avoid frequent adaptation due to small changes in the input signal, you can define a hysteresis. This setting defines an upper threshold that the signal must exceed (compared to the last measurement) before the reference level is adapted automatically.

Remote command:

[\[SENSe:\]ADJust:CONFigure:HYSTeresis:UPPer](#) on page 147

Lower Level Hysteresis

When the reference level is adjusted automatically using the [Auto Level](#) function, the internal attenuators and the preamplifier are also adjusted. To avoid frequent adaptation due to small changes in the input signal, you can define a hysteresis. This setting defines a lower threshold that the signal must fall below (compared to the last measurement) before the reference level is adapted automatically.

Remote command:

`[SENSe:]ADJust:CONFigure:HYSTeresis:LOWer` on page 147

6 Analysis

General result analysis settings concerning the trace, markers, lines etc. can be configured via the "Analysis" button in the "Overview". They are similar to the analysis functions in the Spectrum application, except for the features described here.

For more information, please refer to the R&S FSWP User Manual.

- [Trace configuration](#)..... 76
- [Marker settings](#).....77
- [Display lines and limit lines](#)..... 77

6.1 Trace configuration

Access

- "Overview" > "Analysis" > "Trace"

For more information, refer to the R&S FSWP user manual.

Spectrograms in the I/Q analyzer

Basically, spectrograms work the same as in the spectrum application (including the 3D spectrogram).

However, in the I/Q analyzer, they have the following distinctive features.

- Not all result displays support spectrograms.
- Compared to the spectrum application, a spectrogram can not be added as an independent result display. Instead, spectrograms relate to a certain measurement window (or result display). Result diagram and spectrogram are a single entity in that case and can not be divided.
- You can assign a specific trace to the spectrogram.

To view results in a spectrogram, select a window (indicated by a blue frame), then select [TRACE] > "Spectrogram Config".

Spectrograms are either displayed in "Split" mode (spectrogram is displayed below the trace diagram), in "Full" mode (trace diagram is not displayed), or not displayed at all ("Off").

When the "Spectrogram Config" softkey is greyed out, spectrograms are not supported by the selected result display.

State	76
Trace	77

State

Activates and deactivates a Spectrogram subwindow.

- | | |
|---------|---|
| "Split" | Displays the Spectrogram as a subwindow in the original result display. |
|---------|---|

"Full" Displays the Spectrogram in a subwindow in the full size of the original result display.

"Off" Closes the Spectrogram subwindow.

Remote command:

[CALCulate<n>:SPECTrogram:LAYout](#) on page 156

Trace

Selects the diagram trace on which the spectrogram is based.

Remote command:

[CALCulate<n>:SGRam:TRACe](#) on page 157

6.2 Marker settings

Access

- "Overview" > "Analysis" > "Marker"
- "Overview" > "Analysis" > "Marker Function"

For more information, refer to the R&S FSWP user manual.

[Branch for Peaksearch](#).....77

Branch for Peaksearch

Defines which data is used for marker search functions in I/Q data.

This function is only available for the display configuration "Real/Imag (I/Q)" (see ["Real/Imag \(I/Q\)"](#) on page 20).

Note: The search settings apply to all markers, not only the currently selected one.

"Real"

Marker search functions are performed on the real trace of the I/Q measurement.

"Imag"

Marker search functions are performed on the imaginary trace of the I/Q measurement.

"Magnitude"

Marker search functions are performed on the magnitude of the I and Q data.

Remote command:

[CALCulate<n>:MARKer<m>:SEARch](#) on page 156

6.3 Display lines and limit lines

Access (limit lines): "Overview" > "Analysis" > "Lines" > "Limit Lines"

Access (display lines): "Overview" > "Analysis" > "Lines" > "Display Lines"

For more information, refer to the R&S FSWP user manual.

7 How to work with I/Q data

The following step-by-step procedures demonstrate in detail how to perform various tasks when working with I/Q data.

- [How to perform measurements in the I/Q Analyzer application](#).....79
- [How to export and import I/Q data](#)..... 80

7.1 How to perform measurements in the I/Q Analyzer application

The following step-by-step instructions demonstrate how to capture I/Q data on the R&S FSWP and how to analyze data in the I/Q Analyzer application.



How to perform a measurement in the time or frequency domain on I/Q data (in MSRA mode only) is described in the R&S FSWP MSRA User Manual.

- [How to capture baseband \(I/Q\) data as RF input](#).....79
- [How to analyze data in the I/Q Analyzer](#).....80

7.1.1 How to capture baseband (I/Q) data as RF input

By default, the I/Q Analyzer assumes the I/Q data is modulated on a carrier frequency and input via the "RF Input" connector on the R&S FSWP.

1. Select [MODE] and select the "I/Q Analyzer" application.
2. Select "Overview" to display the "Overview" for an I/Q Analyzer measurement.
3. Select "Input" to select and configure the "RF Input" signal source.
4. Select "Amplitude" to define the attenuation, reference level or other settings that affect the input signal's amplitude and scaling.
5. Select "Frequency" to define the input signal's center frequency.
6. Optionally, select "Trigger" and define a trigger for data acquisition, for example an I/Q Power trigger to start capturing data only when a specific power is exceeded.
7. Select "Bandwidth" and define the bandwidth parameters for data acquisition:
 - "Sample Rate" or "Analysis Bandwidth" the span of the input signal to be captured for analysis, or the rate at which samples are captured (both values are correlated)
 - "Measurement Time" how long the data is to be captured
 - "Record Length": the number of samples to be captured (also defined by sample rate and measurement time)

8. Select "Display Config" and select up to six displays that are of interest to you. Arrange them on the display to suit your preferences.
9. Exit the SmartGrid mode.
10. Start a new sweep with the defined settings.
 - a) Select the Sequencer icon () from the toolbar.
 - b) Set the Sequencer state to "Off".
 - c) Select [RUN SINGLE].

7.1.2 How to analyze data in the I/Q Analyzer

1. Select [MODE] and select the "I/Q Analyzer" application.
2. Select "Overview" to display the "Overview" for an I/Q Analyzer measurement.
3. Select "Display Config" and select up to six displays that are of interest to you. Arrange them on the display to suit your preferences.
4. Exit the SmartGrid mode and select "Overview" to display the "Overview" again.
5. Select "Analysis" in the "Overview" to make use of the advanced analysis functions in the displays.
 - Configure a trace to display the average over a series of sweeps (on the "Trace" tab; if necessary, increase the "Average Count").
 - Configure markers and delta markers to determine deviations and offsets within the signal (on the "Marker" tab).

7.2 How to export and import I/Q data



I/Q data can only be exported in applications that process I/Q data, such as the I/Q Analyzer or optional applications.

Capturing and exporting I/Q data

1. Press [PRESET].
2. Press [MODE] and select the I/Q Analyzer or any other application that supports I/Q data.
3. Configure the data acquisition.
4. Press [RUN SINGLE] to perform a single sweep measurement.
5. Select the  "Save" icon in the toolbar.
6. Select "I/Q Export".

7. In the file selection dialog box, select a storage location and enter a file name.
8. Select "Save".

The captured data is stored to a file.

The file type is determined by the file extension. If no file extension is provided, the file type is assumed to be `.iq.tar`. For `.mat` files, Matlab® v4 is assumed.

Importing I/Q data

1. Press [MODE] and select the "I/Q Analyzer" or any other application that supports I/Q data.
2. If necessary, switch to single sweep mode by pressing [RUN SINGLE].
3. Select the  "Open" icon in the toolbar.
4. Select "I/Q Import".
5. Select the storage location and the file name.
The file type is determined by the file extension. If no file extension is provided, the file type is assumed to be `.iq.tar`. For `.mat` files, Matlab® v4 is assumed.
6. Select "Open".

The stored data is loaded from the file and displayed in the current application.

Previewing the I/Q data in a web browser

The `iq-tar` file format allows you to preview the I/Q data in a web browser.

1. Use an archive tool (e.g. WinZip® or PowerArchiver®) to unpack the `iq-tar` file into a folder.
2. Locate the folder using Windows Explorer.
3. Open your web browser.

4. Drag the I/Q parameter XML file, e.g. `example.xml`, into your web browser.

xzy.xml (of .iq.tar file)

Description	
Saved by	FSV IQ Analyzer
Comment	Here is a comment
Date & Time	2011-03-03 14:33:05
Sample rate	6.5 MHz
Number of samples	65000
Duration of signal	10 ms
Data format	complex, float32
Data filename	xzy.complex.1ch.float32
Scaling factor	1 V

Channel 1

Comment	Channel 1 of 1
Power vs time y-axis: 10 dB /div x-axis: 1 ms /div	
Spectrum y-axis: 20 dB /div x-axis: 500 kHz /div	

E-mail: info@rohde-schwarz.com
 Internet: <http://www.rohde-schwarz.com>
 Fileformat version: 1

8 Remote commands for the I/Q analyzer

The following commands are specific to performing measurements in the I/Q Analyzer application in a remote environment. The R&S FSWP must already be set up for remote operation in a network as described in the R&S FSWP user manual.

• Introduction	83
• Common suffixes	88
• Activating I/Q analyzer measurements	89
• Performing measurements	95
• Retrieving results	102
• Configuring I/Q analyzer measurements	114
• Analyzing results	156
• Importing and exporting I/Q data	157
• Querying the status registers	158
• Programming examples	159

8.1 Introduction

Commands are program messages that a controller (e.g. a PC) sends to the instrument or software. They operate its functions ('setting commands' or 'events') and request information ('query commands'). Some commands can only be used in one way, others work in two ways (setting and query). If not indicated otherwise, the commands can be used for settings and queries.

The syntax of a SCPI command consists of a header and, usually, one or more parameters. To use a command as a query, you have to append a question mark after the last header element, even if the command contains a parameter.

A header contains one or more keywords, separated by a colon. Header and parameters are separated by a "white space" (ASCII code 0 to 9, 11 to 32 decimal, e.g. blank). If there is more than one parameter for a command, they are separated by a comma from one another.

Only the most important characteristics that you need to know when working with SCPI commands are described here. For a more complete description, refer to the user manual of the R&S FSWP.



Remote command examples

Note that some remote command examples mentioned in this general introduction are possibly not supported by this particular application.

8.1.1 Conventions used in descriptions

The following conventions are used in the remote command descriptions:

- *Command usage*

If not specified otherwise, commands can be used both for setting and for querying parameters.

If a command can be used for setting or querying only, or if it initiates an event, the usage is stated explicitly.

- *Parameter usage*

If not specified otherwise, a parameter can be used to set a value, and it is the result of a query.

Parameters required only for setting are indicated as "Setting parameters".

Parameters required only to refine a query are indicated as "Query parameters".

Parameters that are only returned as the result of a query are indicated as "Return values".

- *Conformity*

Commands that are taken from the SCPI standard are indicated as "SCPI confirmed". All commands used by the R&S FSWP follow the SCPI syntax rules.

- *Asynchronous commands*

A command which does not automatically finish executing before the next command starts executing (overlapping command) is indicated as an "Asynchronous command".

- *Reset values (*RST)*

Default parameter values that are used directly after resetting the instrument (*RST command) are indicated as "*RST" values, if available.

- *Default unit*

The default unit is used for numeric values if no other unit is provided with the parameter.

- *Manual operation*

If the result of a remote command can also be achieved in manual operation, a link to the description is inserted.

8.1.2 Long and short form

The keywords have a long and a short form. You can use either the long or the short form, but no other abbreviations of the keywords.

The short form is emphasized in uppercase letters. Note however, that this emphasis only serves the purpose to distinguish the short from the long form in the manual. For the instrument, the case does not matter.

Example:

SENSe:FREQuency:CENTer is the same as SENS:FREQ:CENT.

8.1.3 Numeric suffixes

Some keywords have a numeric suffix if the command can be applied to multiple instances of an object. In that case, the suffix selects a particular instance (e.g. a measurement window).

Numeric suffixes are indicated by angular brackets (<n>) next to the keyword.

If you do not quote a suffix for keywords that support one, a 1 is assumed.

Example:

`DISPlay[:WINDow<1...4>]:ZOOM:STATe` enables the zoom in a particular measurement window, selected by the suffix at `WINDow`.

`DISPlay:WINDow4:ZOOM:STATe ON` refers to window 4.

8.1.4 Optional keywords

Some keywords are optional and are only part of the syntax because of SCPI compliance. You can include them in the header or not.



If an optional keyword has a numeric suffix and you need to use the suffix, you have to include the optional keyword. Otherwise, the suffix of the missing keyword is assumed to be the value 1.

Optional keywords are emphasized with square brackets.

Example:

Without a numeric suffix in the optional keyword:

`[SENSe:]FREQuency:CENTer` is the same as `FREQuency:CENTer`

With a numeric suffix in the optional keyword:

`DISPlay[:WINDow<1...4>]:ZOOM:STATe`

`DISPlay:ZOOM:STATe ON` enables the zoom in window 1 (no suffix).

`DISPlay:WINDow4:ZOOM:STATe ON` enables the zoom in window 4.

8.1.5 Alternative keywords

A vertical stroke indicates alternatives for a specific keyword. You can use both keywords to the same effect.

Example:

`[SENSe:]BANDwidth|BWIDth[:RESolution]`

In the short form without optional keywords, `BAND 1MHZ` would have the same effect as `BWID 1MHZ`.

8.1.6 SCPI parameters

Many commands feature one or more parameters.

If a command supports more than one parameter, they are separated by a comma.

Example:

```
LAYout:ADD:WINDow Spectrum,LEFT,MTABLE
```

Parameters can have different forms of values.

- [Numeric values](#)..... 86
- [Boolean](#)..... 87
- [Character data](#)..... 87
- [Character strings](#)..... 87
- [Block data](#)..... 87

8.1.6.1 Numeric values

Numeric values can be entered in any form, i.e. with sign, decimal point or exponent. For physical quantities, you can also add the unit. If the unit is missing, the command uses the basic unit.

Example:

With unit: `SENSe:FREQuency:CENTer 1GHZ`

Without unit: `SENSe:FREQuency:CENTer 1E9` would also set a frequency of 1 GHz.

Values exceeding the resolution of the instrument are rounded up or down.

If the number you have entered is not supported (e.g. for discrete steps), the command returns an error.

Instead of a number, you can also set numeric values with a text parameter in special cases.

- **MIN/MAX**
Defines the minimum or maximum numeric value that is supported.
- **DEF**
Defines the default value.
- **UP/DOWN**
Increases or decreases the numeric value by one step. The step size depends on the setting. Sometimes, you can customize the step size with a corresponding command.

Querying numeric values

When you query numeric values, the system returns a number. For physical quantities, it applies the basic unit (e.g. Hz for frequencies). The number of digits after the decimal point depends on the type of numeric value.

Example:

Setting: `SENSe:FREQuency:CENTer 1GHZ`

Query: `SENSe:FREQuency:CENTer?` would return `1E9`

Sometimes, numeric values are returned as text.

- **INF/NINF**
Infinity or negative infinity. Represents the numeric values 9.9E37 or -9.9E37.
- **NAN**
Not a number. Represents the numeric value 9.91E37. NAN is returned if errors occur.

8.1.6.2 Boolean

Boolean parameters represent two states. The "on" state (logically true) is represented by "ON" or the numeric value 1. The "off" state (logically untrue) is represented by "OFF" or the numeric value 0.

Querying Boolean parameters

When you query Boolean parameters, the system returns either the value 1 ("ON") or the value 0 ("OFF").

Example:

Setting: `DISPlay:WINDow:ZOOM:STATe ON`

Query: `DISPlay:WINDow:ZOOM:STATe?` would return 1

8.1.6.3 Character data

Character data follows the syntactic rules of keywords. You can enter text using a short or a long form. For more information, see [Section 8.1.2, "Long and short form"](#), on page 84.

Querying text parameters

When you query text parameters, the system returns its short form.

Example:

Setting: `SENSe:BANDwidth:RESolution:TYPE NORMAL`

Query: `SENSe:BANDwidth:RESolution:TYPE?` would return NORM

8.1.6.4 Character strings

Strings are alphanumeric characters. They have to be in straight quotation marks. You can use a single quotation mark (') or a double quotation mark (").

Example:

`INSTRument:DELeTe 'Spectrum'`

8.1.6.5 Block data

Block data is a format which is suitable for the transmission of large amounts of data.

The ASCII character # introduces the data block. The next number indicates how many of the following digits describe the length of the data block. The data bytes follow. During the transmission of these data bytes, all end or other control signs are ignored until all bytes are transmitted. #0 specifies a data block of indefinite length. The use of the indefinite format requires an `NL^END` message to terminate the data block. This format is useful when the length of the transmission is not known or if speed or other considerations prevent segmentation of the data into blocks of definite length.

8.2 Common suffixes

In the I/Q Analyzer, the following common suffixes are used in remote commands:

Table 8-1: Common suffixes used in remote commands in the I/Q Analyzer

Suffix	Value range	Description
<m>	1 to 16	Marker (or spot noise marker)
<n>	1 to 6	Window (in the currently selected channel)
<t>	1 to 6	Trace
	1 to 8	Limit line By default, the suffixes 1 to 8 correspond to the lines REM1 to REM8. If they are used but do not yet exist, they are created automatically. If a name has been set via <code>CALCulate:LIMit:NAME</code> , you can access the corresponding line using its index.



Selecting windows in multiple channels

Note that the suffix <n> always refers to a window in the currently selected channel.

<m>	1 to 16	Marker (or spot noise marker)
<j>	1..10	Selects an integrated measurement range.
<k>	1..8 (Limit line) 1 2 (Display line)	Selects a limit or display line.
<r>	1..x	Selects a half decade. The value range depends on the number of half decades. The first half decade in the measurement always has the value "1". For subsequent half decades, add "1" to get the value "x" (the fourth half decade, for example, would have the value "4").

<s>	1..6	Selects a (user defined) spot noise marker.
<x>	1..2	Selects a mixer in the test setup.



Selecting windows in multiple channels

Note that the suffix <n> always refers to a window in the currently selected channel.

8.3 Activating I/Q analyzer measurements

I/Q Analyzer measurements require a special measurement channel on the R&S FSWP. It can be activated using the common `INSTrument:CREate[:NEW]` or `INSTrument:CREate:REPLace` commands. In this case, some - but not all - parameters from the previously selected application are passed on to the I/Q Analyzer channel. In order to retain *all* relevant parameters from the current application for the I/Q measurement, use the `TRACe:IQ[:STATe]` command to change the application of the current channel.

A measurement is started immediately with the default settings when the channel is activated.



Different remote modes available

In remote control, two different modes for the I/Q Analyzer measurements are available:

- A quick mode for pure data acquisition
This mode is activated by default with the `TRACe:IQ[:STATe]` command. The evaluation functions are not available; however, performance is slightly improved.
- A more sophisticated mode for acquisition and analysis.
This mode is activated when a new channel is opened for the I/Q Analyzer application (`INST:CRE:NEW/ INST:CRE:REPL`) or by an additional command (see `TRACe:IQ:EVAL` on page 94).

<code>CALCulate<n>:IQ:MODE</code>	90
<code>INSTrument:CREate:DUPLicate</code>	90
<code>INSTrument:CREate[:NEW]</code>	90
<code>INSTrument:CREate:REPLace</code>	91
<code>INSTrument:DELeTe</code>	91
<code>INSTrument:LIST?</code>	92
<code>INSTrument:REName</code>	92
<code>INSTrument[:SELeCt]</code>	93
<code>SYSTem:PRESet:CHANnel[:EXEC]</code>	93
<code>TRACe:IQ:EVAL</code>	94
<code>TRACe:IQ[:STATe]</code>	94

CALCulate<n>:IQ:MODE <EvalMode>

This command defines whether the captured I/Q data is evaluated directly, or if it is converted (via FFT) to spectral or time data first.

It is currently only available for I/Q Analyzer secondary applications in multistandard mode (not the MSRA primary application).

Suffix:

<n> irrelevant

Parameters:

<EvalMode>

TDOMain
Evaluation in time domain (zero span).

FDOMain
Evaluation in frequency domain.

IQ
Evaluation using I/Q data.

INSTrument:CREate:DUPLicate

Duplicates the currently selected channel, i.e. creates a new channel of the same type and with the identical measurement settings. The name of the new channel is the same as the copied channel, extended by a consecutive number (e.g. "IQAnalyzer" -> "IQAnalyzer 2").

The channel to be duplicated must be selected first using the `INST:SEL` command.

Is not available if the MSRA primary channel is selected.

Example:

```
INST:SEL 'PhaseNoise'
INST:CRE:DUPL
```

Duplicates the channel named 'PhaseNoise' and creates a new channel named 'PhaseNoise 2'.

Usage:

Event

INSTrument:CREate[:NEW] <ChannelType>, <ChannelName>

Adds a measurement channel. You can configure up to 10 measurement channels at the same time (depending on available memory).

Parameters:

<ChannelType> Channel type of the new channel.
For a list of available channel types, see [INSTrument:LIST?](#) on page 92.

<ChannelName> String containing the name of the channel.
 Note that you cannot assign an existing channel name to a new channel. If you do, an error occurs.
 Channel names can have a maximum of 31 characters, and must be compatible with the Windows conventions for file names. In particular, they must not contain special characters such as ":", "*", "?".

Example: `INST:CRE SAN, 'Spectrum 2'`
 Adds a spectrum display named "Spectrum 2".

INSTrument:CREate:REPLace <ChannelName1>, <ChannelType>, <ChannelName2>

Replaces a channel with another one.

Setting parameters:

<ChannelName1> String containing the name of the channel you want to replace.

<ChannelType> Channel type of the new channel.
 For a list of available channel types, see [INSTrument:LIST?](#) on page 92.

<ChannelName2> String containing the name of the new channel.
Note: If the specified name for a new channel already exists, the default name, extended by a sequential number, is used for the new channel (see [INSTrument:LIST?](#) on page 92).
 Channel names can have a maximum of 31 characters, and must be compatible with the Windows conventions for file names. In particular, they must not contain special characters such as ":", "*", "?".

Example: `INST:CRE:REPL 'PhaseNoise', PNO, 'PNO2'`
 Replaces the channel named "PhaseNoise" by a new channel of type "Phase Noise" named "PNO2".

Usage: Setting only

INSTrument:DELeTe <ChannelName>

Deletes a channel.

If you delete the last channel, the default "Phase Noise" channel is activated.

Setting parameters:

<ChannelName> String containing the name of the channel you want to delete.
 A channel must exist to delete it.

Example: `INST:DEL 'PhaseNoise'`
 Deletes the channel with the name 'PhaseNoise'.

Usage: Setting only

INSTrument:LIST?

Queries all active channels. The query is useful to obtain the names of the existing channels, which are required to replace or delete the channels.

Return values:

<ChannelType>, For each channel, the command returns the channel type and
<ChannelName> channel name (see tables below).

Tip: to change the channel name, use the `INSTrument:REName` command.

Example:

`INST:LIST?`

Result for 2 channels:

`'PNO', 'PhaseNoise', 'PNO', 'Phase Noise 2'`

Usage:

Query only

Table 8-2: Available channel types and default channel names

Application	<ChannelType> Parameter	Default Channel Name*)
Phase Noise	PNOise	Phase Noise
Spectrum Monitor	SMONitor	Spectrum Monitor
Spectrum (R&S FSWP-B1)	SANalyzer	Spectrum
I/Q Analyzer (R&S FSWP-B1)	IQ	IQ Analyzer
Pulse Measurements (R&S FSWP-K6)	PULSe	Pulse
Analog Modulation Analysis (R&S FSWP-K7)	ADEMod	Analog Demod
Noise Figure Measurements (R&S FSWP-K30)	NOISe	Noise
Fast Spur Search (R&S FSWP-K50)	SPUR	Spurious
Transient Analysis (R&S FSWP-K60)	TA	Transient Analysis
Vector Signal Analysis (R&S FSWP-K70)	DDEM	VSA

Note: the default channel name is also listed in the table. If the specified name for a new channel already exists, the default name, extended by a sequential number, is used for the new channel.

INSTrument:REName <ChannelName1>, <ChannelName2>

Renames a channel.

Setting parameters:

<ChannelName1> String containing the name of the channel you want to rename.

<ChannelName2> String containing the new channel name.
 Note that you cannot assign an existing channel name to a new channel. If you do, an error occurs.
 Channel names can have a maximum of 31 characters, and must be compatible with the Windows conventions for file names. In particular, they must not contain special characters such as ":", "*", "?".

Example: `INST:REN 'PhaseNoise', 'PNO'`
 Renames the channel with the name 'PhaseNoise' to 'PNO'.

Usage: Setting only

INSTrument[:SElect] <ChannelType> | <ChannelName>

Activates a new channel with the defined channel type, or selects an existing channel with the specified name.

Also see

- [INSTrument:CREate\[:NEW\]](#) on page 90

Parameters:

<ChannelType> Channel type of the new channel.
 For a list of available channel types see [INSTrument:LIST?](#) on page 92.

<ChannelName> String containing the name of the channel.

Example: `INST IQ`
 Activates a channel for the I/Q Analyzer application (evaluation mode).
 To start a channel in the simple I/Q Analyzer mode, use [TRACe:IQ\[:STATE\]](#).
`INST 'MyIQSpectrum'`
 Selects the channel named 'MyIQSpectrum' (for example before executing further commands for that channel).

SYSTem:PRESet:CHANnel[:EXEC]

Restores the default instrument settings in the current channel.

Use `INST:SEL` to select the channel.

Example: `INST:SEL 'Spectrum2'`
 Selects the channel for "Spectrum2".
`SYST:PRESet:CHAN:EXEC`
 Restores the factory default settings to the "Spectrum2" channel.

Usage: Event

Manual operation: See "[Preset Channel](#)" on page 42

TRACe:IQ:EVAL <State>

Turns I/Q data analysis on and off.

Before you can use this command, you have to turn on the I/Q data acquisition using `INST:CRE:NEW IQ` or `INST:CRE:REPL`, or using the `TRACe:IQ[:STATe]` command to replace the current channel while retaining the settings.

Parameters:

<State> **ON | OFF | 0 | 1**
 OFF | 0
 Switches the function off
 ON | 1
 Switches the function on

Example:

```
TRAC:IQ ON
Enables I/Q data acquisition
TRAC:IQ:EVAL ON
Enables the I/Q data analysis mode.
```

TRACe:IQ[:STATe] <State>

Activates the simple I/Q data acquisition mode (see [Section 8.3, "Activating I/Q analyzer measurements"](#), on page 89).

Executing this command also has the following effects:

- The sweep, amplitude, input and trigger settings from the measurement are retained.
- All measurements are turned off.
- All traces are set to "Blank" mode.
- The I/Q data analysis mode is turned off (`TRAC:IQ:EVAL OFF`).

Note: To turn trace display back on or to enable the evaluation functions of the I/Q Analyzer, execute the `TRAC:IQ:EVAL ON` command (see [TRACe:IQ:EVAL](#) on page 94).

Parameters:

<State> **ON | OFF | 0 | 1**
 OFF | 0
 Switches the function off
 ON | 1
 Switches the function on

Example:

```
TRAC:IQ ON
Switches on I/Q data acquisition
```

8.4 Performing measurements



Different measurement procedures

Two different procedures to capture I/Q data remotely are available:

- Measurement and result query with one command (see [TRACe:IQ:DATA?](#) on page 103)
This method causes the least delay between measurement and output of the result data, but it requires the control computer to wait actively for the response data.
- Setting up the instrument, starting the measurement via `INIT` and querying the result list at the end of the measurement (see [TRACe:IQ:DATA:MEMory?](#) on page 104)
With this method, the control computer can be used for other activities during the measurement. However, the additional time needed for synchronization via service request must be taken into account.

ABORt	95
INITiate<n>:CONMeas	96
INITiate<n>:CONTinuous	97
INITiate<n>[:IMMEDIATE]	98
INITiate:SEQuencer:ABORt	98
INITiate:SEQuencer:IMMEDIATE	98
INITiate:SEQuencer:MODE	99
INITiate:SEQuencer:REFRESH[:ALL]	99
[SENSe:]AVERAge:COUNT	99
TRACe:IQ:AVERAge:COUNT	99
[SENSe:]AVERAge<n>[:STATe<t>]	100
TRACe:IQ:AVERAge[:STATe]	100
[SENSe:]SWEep:COUNT	100
[SENSe:]SWEep:COUNT:CURRent?	101
[SENSe:]SWEep[:WINDow<n>]:POINts	101
[SENSe:]SWEep:TIME	101
SYSTem:SEQuencer	102

ABORt

Aborts the measurement in the current channel and resets the trigger system.

To prevent overlapping execution of the subsequent command before the measurement has been aborted successfully, use the `*OPC?` or `*WAI` command after `ABOR` and before the next command.

For details on overlapping execution see [Remote control via SCPI](#).

To abort a sequence of measurements by the Sequencer, use the `INITiate:SEQuencer:ABORt` command.

Note on blocked remote control programs:

If a sequential command cannot be completed, for example because a triggered sweep never receives a trigger, the remote control program will never finish and the remote channel to the R&S FSWP is blocked for further commands. In this case, you must interrupt processing on the remote channel first in order to abort the measurement.

To do so, send a "Device Clear" command from the control instrument to the R&S FSWP on a parallel channel to clear all currently active remote channels. Depending on the used interface and protocol, send the following commands:

- **Visa:** `viClear()`
- **GPIB:** `ibclr()`
- **RSIB:** `RSDLLibclr()`

Now you can send the `ABORt` command on the remote channel performing the measurement.

Example: `ABOR; :INIT:IMM`
Aborts the current measurement and immediately starts a new one.

Example: `ABOR; *WAI`
`INIT:IMM`
Aborts the current measurement and starts a new one once abortion has been completed.

Usage: Event

INITiate<n>:CONMeas

Restarts a (single) measurement that has been stopped (using `ABORt`) or finished in single measurement mode.

The measurement is restarted at the beginning, not where the previous measurement was stopped.

As opposed to `INITiate<n>[:IMMEDIATE]`, this command does not reset traces in maxhold, minhold or average mode. Therefore it can be used to continue measurements using maxhold or averaging functions.

Suffix:
<n> irrelevant

Example:	<pre>INIT:CONT OFF</pre> <p>Switches to single measurement mode.</p> <pre>DISP:WIND:TRAC:MODE AVER</pre> <p>Switches on trace averaging.</p> <pre>SWE:COUN 20</pre> <p>Setting the measurement counter to 20 measurements.</p> <pre>INIT;*WAI</pre> <p>Starts the measurement and waits for the end of the 20 measurements.</p> <pre>INIT:CONM;*WAI</pre> <p>Continues the measurement (next 20 measurements) and waits for the end.</p> <p>Result: Averaging is performed over 40 measurements.</p>
Usage:	Asynchronous command
Manual operation:	See " Continue Single Sweep " on page 72

INITiate<n>:CONTInuous <State>

Controls the measurement mode for an individual channel.

Note that in single measurement mode, you can synchronize to the end of the measurement with *OPC, *OPC? or *WAI. In continuous measurement mode, synchronization to the end of the measurement is not possible. Thus, it is not recommended that you use continuous measurement mode in remote control, as results like trace data or markers are only valid after a single measurement end synchronization.

For details on synchronization see [Remote control via SCPI](#).

If the measurement mode is changed for a channel while the Sequencer is active, the mode is only considered the next time the measurement in that channel is activated by the Sequencer.

Suffix:

<n> irrelevant

Parameters:

<State> ON | OFF | 0 | 1

ON | 1
Continuous measurement

OFF | 0
Single measurement

*RST: 1 (some applications can differ)

Example:	<pre>INIT:CONT OFF</pre> <p>Switches the measurement mode to single measurement.</p> <pre>INIT:CONT ON</pre> <p>Switches the measurement mode to continuous measurement.</p>
-----------------	--

Manual operation: See "[Continuous Sweep / Run Cont](#)" on page 71

INITiate<n>[:IMMediate]

Starts a (single) new measurement.

With measurement count or average count > 0, this means a restart of the corresponding number of measurements. With trace mode MAXHold, MINHold and AVERage, the previous results are reset on restarting the measurement.

You can synchronize to the end of the measurement with *OPC, *OPC? or *WAI.

For details on synchronization see [Remote control via SCPI](#).

Suffix:

<n> irrelevant

Example:

```
INIT:CONT OFF
```

Switches to single measurement mode.

```
DISP:WIND:TRAC:MODE AVER
```

Switches on trace averaging.

```
SWE:COUN 20
```

Sets the measurement counter to 20 measurements.

```
INIT;*WAI
```

Starts the measurement and waits for the end of the 20 measurements.

Usage: Asynchronous command

Manual operation: See "[Single Sweep / Run Single](#)" on page 71

INITiate:SEQuencer:ABORt

Stops the currently active sequence of measurements.

You can start a new sequence any time using [INITiate:SEQuencer:IMMediate](#) on page 98.

Usage: Event

INITiate:SEQuencer:IMMediate

Starts a new sequence of measurements by the Sequencer.

Its effect is similar to the [INITiate<n>\[:IMMediate\]](#) command used for a single measurement.

Before this command can be executed, the Sequencer must be activated (see [SYSTem:SEQuencer](#) on page 102).

Example:

```
SYST:SEQ ON
```

Activates the Sequencer.

```
INIT:SEQ:MODE SING
```

Sets single sequence mode so each active measurement is performed once.

```
INIT:SEQ:IMM
```

Starts the sequential measurements.

INITiate:SEQuencer:MODE <Mode>

Defines the capture mode for the entire measurement sequence and all measurement groups and channels it contains.

Note: To synchronize to the end of a measurement sequence using *OPC, *OPC? or *WAI, use **SINGLe** Sequencer mode.

Parameters:

<Mode>

SINGle

Each measurement group is started one after the other in the order of definition. All measurement channels in a group are started simultaneously and performed once. After *all* measurements are completed, the next group is started. After the last group, the measurement sequence is finished.

CONTInuous

Each measurement group is started one after the other in the order of definition. All measurement channels in a group are started simultaneously and performed once. After *all* measurements are completed, the next group is started. After the last group, the measurement sequence restarts with the first one and continues until it is stopped explicitly.

*RST: CONTInuous

INITiate:SEQuencer:REFResh[:ALL]

Is only available if the Sequencer is deactivated (**SYSTem:SEQuencer** **SYST:SEQ:OFF**) and only in MSRA mode.

The data in the capture buffer is re-evaluated by all active MSRA secondary applications.

Example:

SYST:SEQ:OFF

Deactivates the scheduler

INIT:CONT OFF

Switches to single sweep mode.

INIT;*WAI

Starts a new data measurement and waits for the end of the sweep.

INIT:SEQ:REFR

Refreshes the display for all channels.

[SENSe:]AVERAge:COUnT <AverageCount>**TRACe:IQ:AVERAge:COUnT** <NumberSets>

This command defines the number of I/Q data sets that the averaging is based on.

Parameters:

<NumberSets>

Range: 0 to 32767

*RST: 0

Example:

```
TRAC:IQ ON
Switches on acquisition of I/Q data.
TRAC:IQ:AVER ON
Enables averaging of the I/Q measurement data
TRAC:IQ:AVER:COUN 10
Selects averaging over 10 data sets
TRAC:IQ:DATA?
Starts the measurement and reads out the averaged data.
```

Manual operation: See "[Sweep/Average Count](#)" on page 71

[SENSe:]AVERage<n>[:STATe<t>] <State>
TRACe:IQ:AVERage[:STATe] <State>

This command turns averaging of the I/Q data on and off.

Before you can use the command you have to turn the I/Q data acquisition on with [TRACe:IQ\[:STATe\]](#).

If averaging is on, the maximum amount of I/Q data that can be recorded is 512kS (524288 samples).

Parameters:

<State>

ON | OFF | 0 | 1

OFF | 0
Switches the function off

ON | 1
Switches the function on

Example:

```
TRAC:IQ ON
Switches on acquisition of I/Q data.
TRAC:IQ:AVER ON
Enables averaging of the I/Q measurement data.
TRAC:IQ:AVER:COUN 10
Selects averaging over 10 data sets.
TRAC:IQ:DATA?
Starts the measurement and reads out the averaged data.
```

[SENSe:]SWEep:COUNT <SweepCount>

Defines the number of measurements that the application uses to average traces.

In continuous measurement mode, the application calculates the moving average over the average count.

In single measurement mode, the application stops the measurement and calculates the average after the average count has been reached.

Example: SWE:COUN 64
 Sets the number of measurements to 64.
 INIT:CONT OFF
 Switches to single measurement mode.
 INIT;*WAI
 Starts a measurement and waits for its end.

Manual operation: See "[Sweep/Average Count](#)" on page 71

[SENSe:]SWEep:COUNT:CURRent?

This query returns the current number of started sweeps or measurements. This command is only available if a sweep count value is defined and the instrument is in single sweep mode.

Return values:
 <CurrentCount>

Example: SWE:COUNT 64
 Sets sweep count to 64
 INIT:CONT OFF
 Switches to single sweep mode
 INIT
 Starts a sweep (without waiting for the sweep end!)
 SWE:COUN:CURR?
 Queries the number of started sweeps

Usage: Query only

[SENSe:]SWEep[:WINDow<n>]:POINTs <SweepPoints>

This command defines the number of measurement points to analyze after a measurement.

Suffix:
 <n>

Example: SWE:POIN 251

Manual operation: See "[Sweep Points](#)" on page 70

[SENSe:]SWEep:TIME <Time>

Defines the measurement time. It automatically decouples the time from any other settings.

Parameters:
 <Time> refer to specifications document
 *RST: depends on current settings (determined automatically)
 Default unit: S

Manual operation: See "[Meas Time](#)" on page 67

SYSTem:SEQuencer <State>

Turns the Sequencer on and off. The Sequencer must be active before any other Sequencer commands (`INIT:SEQ...`) are executed, otherwise an error occurs.

A detailed programming example is provided in the "Operating Modes" section in the R&S FSWP User Manual.

Parameters:

<State>

ON | OFF | 0 | 1

ON | 1

The Sequencer is activated and a sequential measurement is started immediately.

OFF | 0

The Sequencer is deactivated. Any running sequential measurements are stopped. Further Sequencer commands (`INIT:SEQ...`) are not available.

*RST: 0

Example:`SYST:SEQ ON`

Activates the Sequencer.

`INIT:SEQ:MODE SING`

Sets single Sequencer mode so each active measurement is performed once.

`INIT:SEQ:IMM`

Starts the sequential measurements.

`SYST:SEQ OFF`

8.5 Retrieving results

The following commands can be used to retrieve the results of the I/Q Analyzer measurement.



Storing large amounts of I/Q data

When storing large amounts of I/Q data to a file, consider the following tips to improve performance:

- If capturing and storing the I/Q data is the main goal of the measurement and evaluation functions are not required, use the basic I/Q data acquisition mode (see [TRACe: IQ\[:STATe\]](#) on page 94).
- Use a HiSlip or raw socket connection to export the data from the R&S FSWP to a PC.
- Export the data in binary format rather than ASCII format (see [Section A.1, "Formats for returned values: ASCII format and binary format"](#), on page 163).
- Use the "Compatible" or "IQPair" data mode (see [Section A.2, "Reference: format description for I/Q data files"](#), on page 163).
- If only an extract of the available data is relevant, use the [TRACe<n>\[:DATA\]:MEMory?](#) command to store only the required section of data.

- [Retrieving captured I/Q data](#)..... 103
- [Retrieving I/Q trace data](#)..... 106
- [Retrieving marker and peak search results](#)..... 111

8.5.1 Retrieving captured I/Q data

The captured I/Q data is output in the form of a list, three different formats can be selected for this list (see [TRACe: IQ:DATA:FORMat](#) on page 104).

For details on formats refer to [Section A.2, "Reference: format description for I/Q data files"](#), on page 163.

TRACe:IQ:DATA?	103
TRACe:IQ:DATA:FORMat	104
TRACe:IQ:DATA:MEMory?	104

TRACe:IQ:DATA?

Initiates a measurement with the current settings and returns the captured data from I/Q measurements.

Corresponds to:

```
INIT:IMM;*WAI;:TRACe:IQ:DATA:MEMory?
```

However, the [TRACe: IQ:DATA?](#) command is quicker in comparison.

Note: Using the command with the *RST values for the [TRACe: IQ:SET](#) command, the following minimum buffer sizes for the response data are recommended: ASCII format 10 kBytes, binary format: 2 kBytes

Return values:

<Results> Measured voltage for I and Q component for each sample that has been captured during the measurement.
 The number of samples depends on `TRACe:IQ:SET`. In ASCII format, the number of results is 2* the number of samples.
 The data format depends on `TRACe:IQ:DATA:FORMat` on page 104.
 Default unit: V

Example:

```
TRAC:IQ:STAT ON
Enables acquisition of I/Q data
TRAC:IQ:SET NORM,10MHz,32MHz,EXT,POS,0,4096
Measurement configuration:
Sample Rate = 32 MHz
Trigger Source = External
Trigger Slope = Positive
Pretrigger Samples = 0
Number of Samples = 4096
FORMat REAL,32
Selects format of response data
TRAC:IQ:DATA?
Starts measurement and reads results
```

Usage:

Query only

TRACe:IQ:DATA:FORMat <Format>

Selects the order of the I/Q data.

For details see [Section A.2, "Reference: format description for I/Q data files"](#), on page 163.

Parameters:

<Format> COMPatible | IQBLock | IQPair

COMPatible

I and Q values are separated and collected in blocks: A block (512k) of I values is followed by a block (512k) of Q values, followed by a block of I values, followed by a block of Q values etc.
 (I,I,I,I,Q,Q,Q,Q,I,I,I,I,Q,Q,Q,Q...)

IQBLock

First all I-values are listed, then the Q-values
 (I,I,I,I,I,...Q,Q,Q,Q,Q,Q)

IQPair

One pair of I/Q values after the other is listed
 (I,Q,I,Q,I,Q...).

*RST: IQBL

TRACe:IQ:DATA:MEMory? [<OffsetSamples>,<NoOfSamples>]

Queries the I/Q data currently stored in the capture buffer of the R&S FSWP.

By default, the command returns all I/Q data in the memory. You can, however, narrow down the amount of data that the command returns using the optional parameters.

If no parameters are specified with the command, the entire trace data is retrieved.

In this case, the command returns the same results as `TRACe:IQ:DATA?`. (Note, however, that the `TRAC:IQ:DATA?` command initiates a new measurement before returning the captured values, rather than returning the existing data in the memory.)

The command returns a comma-separated list of the measured values in floating point format (comma-separated values = CSV). The number of values returned is 2 * the number of complex samples.

The total number of complex samples is displayed in the channel bar in manual operation and can be calculated as:

$$\langle \text{SampleRate} \rangle * \langle \text{CaptureTime} \rangle$$

(See `TRACe:IQ:SET`, `TRACe:IQ:SRATe` on page 143 and `[SENSe:]SWEep:TIME` on page 101)

Query parameters:

`<OffsetSamples>` Selects an offset at which the output of data should start in relation to the first data. If omitted, all captured samples are output, starting with the first sample.

Range: 0 to `<# of samples> - 1`, with `<# of samples>` being the maximum number of captured values

*RST: 0

`<NoOfSamples>` Number of samples you want to query, beginning at the offset you have defined. If omitted, all captured samples (starting at offset) are output.

Range: 1 to `<# of samples> - <offset samples>` with `<# of samples>` maximum number of captured values

*RST: `<# of samples>`

Return values:

`<IQData>` Measured value pair (I,Q) for each sample that has been recorded.

By default, the first half of the list contains the I values, the second half the Q values. The order can be configured using

`TRACe:IQ:DATA:FORMat`.

The data format of the individual values depends on `FORMat[:DATA]` on page 106.

Default unit: V

Example:

```
TRAC:IQ:STAT ON
```

Enables acquisition of I/Q data

```
TRAC:IQ:SET NORM,10MHz,32MHz,EXT,POS,100,4096
```

Measurement configuration:

Sample Rate = 32 MHz

Trigger Source = External

Trigger Slope = Positive

Pretrigger Samples = 100

Number of Samples = 4096

```
INIT;*WAI
```

Starts measurement and wait for sync

```
FORMat REAL,32
```

Determines output format

To read the results:

```
TRAC:IQ:DATA:MEM?
```

Reads all 4096 I/Q data

```
TRAC:IQ:DATA:MEM? 0,2048
```

Reads 2048 I/Q data starting at the beginning of data acquisition

```
TRAC:IQ:DATA:MEM? 2048,1024
```

Reads 1024 I/Q data from half of the recorded data

```
TRAC:IQ:DATA:MEM? 100,512
```

Reads 512 I/Q data starting at the trigger point (<Pretrigger Samples> was 100)

Example:

```
// Perform a single I/Q capture.
```

```
INIT;*WAI
```

```
// Determine output format (binary float32)
```

```
FORMat REAL,32
```

```
// Read 1024 I/Q samples starting at sample 2048.
```

```
TRAC:IQ:DATA:MEM? 2048,1024
```

Usage:

Query only

8.5.2 Retrieving I/Q trace data

FORMat[:DATA].....	106
FORMat:DEXPort:DSEPARATOR.....	107
FORMat:DEXPort:CSEPARATOR.....	108
FORMat:DEXPort:FORMat.....	108
MMEMory:STORE<n>:TRACe.....	108
TRACe<n>[:DATA]?.....	109
TRACe<n>[:DATA]:MEMory?.....	110
TRACe<n>[:DATA]:X?.....	111

FORMat[:DATA] <Format>[, <BitLength>]

Selects the data format that is used for transmission of trace data from the R&S FSWP to the controlling computer.

Note that the command has no effect for data that you send to the R&S FSWP. The R&S FSWP automatically recognizes the data it receives, regardless of the format.

Parameters:

<Format>

ASCIi

ASCIi format, separated by commas.

This format is almost always suitable, regardless of the actual data format. However, the data is not as compact as other formats can be.

REAL

Floating-point numbers (according to IEEE 754) in the "definite length block format".

The format setting `REAL` is used for the binary transmission of trace data.

<BitLength>

Length in bits for floating-point results

16

16-bit floating-point numbers.

Compared to `REAL, 32` format, half as many numbers are returned.

32

32-bit floating-point numbers

For I/Q data, 8 bytes per sample are returned for this format setting.

64

64-bit floating-point numbers

Compared to `REAL, 32` format, twice as many numbers are returned.

Example:

`FORM REAL, 32`

FORMat:DEXPort:DSEParator <Separator>

Selects the decimal separator for data exported in ASCII format.

Parameters:

<Separator>

POINT | COMMa

COMMa

Uses a comma as decimal separator, e.g. `4,05`.

POINT

Uses a point as decimal separator, e.g. `4.05`.

*RST: *RST has no effect on the decimal separator.
Default is POINT.

Example:

`FORM:DEXP:DSEP POIN`

Sets the decimal point as separator.

Manual operation:

See "[Decimal Separator](#)" on page 45

FORMat:DEXPort:CSEParator <Separator>

Selects the column separator for exported trace data.

The selected value is not affected by a preset. The command therefore has no reset value.

Parameters:

<Separator>

COMMa

Selects a comma as a separator.

SEMicolon

Selects a semicolon as a separator.

TAB

Selects a tabulator as a separator.

*RST: n/a

Example:

```
//Select column separator
FORM:DEXP:CSEP TAB
```

Manual operation: See "[Column Separator](#)" on page 45

FORMat:DEXPort:FORMat <FileFormat>

Determines the format of the ASCII file to be imported or exported. Depending on the external program that creates the data file or evaluates it, a comma-separated list (CSV) or a plain data format (DAT) file is required.

Parameters:

<FileFormat>

CSV | DAT

*RST: DAT

Example:

```
FORM:DEXP:FORM CSV
```

Manual operation: See "[File Type](#)" on page 45

MMEMory:STORe<n>:TRACe <Trace>, <FileName>

Exports trace data from the specified window to an ASCII file.

Secure User Mode

In secure user mode, settings that are stored on the instrument are stored to volatile memory, which is restricted to 256 MB. Thus, a "memory limit reached" error can occur although the hard disk indicates that storage space is still available.

To store data permanently, select an external storage location such as a USB memory device.

For details, see "Protecting Data Using the Secure User Mode" in the "Data Management" section of the R&S FSWP base unit user manual.

Suffix:

<n>

[Window](#)

Parameters:

<Trace> Number of the trace to be stored

<FileName> String containing the path and name of the target file.

Example:

```
MMEM:STOR1:TRAC 1, 'C:\TEST.ASC'
```

Stores trace 1 from window 1 in the file TEST.ASC.

Manual operation: See ["Export Trace to ASCII File"](#) on page 44

TRACe<n>[:DATA]? <ResultType>

This command queries current trace data and measurement results.

The data format depends on [FORMat \[:DATA\]](#) on page 106.

Suffix:

<n> [Window](#)

Query parameters:

<ResultType> Selects the type of result to be returned.
See [Table 8-3](#).

Example:

```
TRAC? TRACE3
```

Queries the data of trace 3.

Manual operation: See ["Magnitude"](#) on page 18
See ["Spectrum"](#) on page 19
See ["I/Q-Vector"](#) on page 19
See ["Real/Imag \(I/Q\)"](#) on page 20

Table 8-3: Return values for result type parameters

Parameter	Result display / measurement	Results
TRACE1 ... TRACE6		Returns the sweep point values as shown in the result display. For the auto peak detector, the command returns positive peak values only. (To retrieve negative peak values, define a second trace with a negative peak detector.)
	"Magnitude" "Spectrum"	Magnitude of the I and Q values (I+jQ) for each sweep point (=1001 values)
	"Real/Imag (I/Q)"	First the real parts for each trace point, then the imaginary parts (I ₁ ,...,I ₁₀₀₁ , Q ₁ ,...,Q ₁₀₀₁).
	"I/Q Vector"	The I and Q values for each trace point are returned (1001 pairs of I and Q values).
LIST	SEM measurements	Peak list evaluation, one peak per range is returned.

Parameter	Result display / measurement	Results
	Spurious emission measurements	Peak list evaluation For each peak, the command returns 11 values in the following order: <ul style="list-style-type: none"> • <No>: range number • <StartFreq>,<StopFreq>: start and stop frequency of the range • <RBW>: resolution bandwidth • <PeakFreq>: frequency of the peak in a range • <PowerAbs>: absolute power of the peak in dBm • <PowerRel>: power of the peak in relation to the channel power in dBc • <PowerDelta>: distance from the peak to the limit line in dB, positive values indicate a failed limit check • <LimitCheck>: state of the limit check (0 = PASS, 1 = FAIL) • <Unused1>,<Unused2>: reserved (0.0)
SPURious		Peak list evaluation of Spurious Emission measurements.
SPECTrogram SGRam		For every frame in the spectrogram, the command returns the power levels that have been measured, one for each sweep point. The number of frames depends on the size of the history depth. The power level depends on the configured unit. Only REAL, 32 format is supported.

TRACe<n>[:DATA]:MEMory? <Trace>,<OffsSwPoint>,<NoOfSwPoints>

Queries the previously captured trace data for the specified trace from the memory. As an offset and number of sweep points to be retrieved can be specified, the trace data can be retrieved in smaller portions, making the command faster than the TRAC:DATA? command. This is useful if only specific parts of the trace data are of interest.

If no parameters are specified with the command, the entire trace data is retrieved; in this case, the command returns the same results as TRAC:DATA? TRACE1.

Suffix:

<n> [Window](#)

Query parameters:

<Trace> TRACE1 | TRACE2 | TRACE3 | TRACE4 | TRACE5 | TRACE6

<OffsSwPoint> The offset in sweep points related to the start of the measurement at which data retrieval is to start.

<NoOfSwPoints> Number of sweep points to be retrieved from the trace.

Return values:

<SweepPointValues>

Example:

TRAC:DATA:MEM? TRACE1,25,100

Retrieves 100 sweep points from trace 1, starting at sweep point 25.

Usage:

Query only

TRACe<n>[:DATA]:X? <TraceNumber>

Queries the horizontal trace data for each sweep point in the specified window, for example the frequency in frequency domain or the time in time domain measurements.

This is especially useful for traces with non-equidistant x-values.

Suffix:

<n> [Window](#)

Query parameters:

<TraceNumber> Trace number.

TRACE1 | TRACE2 | TRACE3 | TRACE4 | TRACE5 | TRACE6

Return values:

<X-Values>

Example:

TRAC3:X? TRACE1

Returns the x-values for trace 1 in window 3.

Usage:

Query only

8.5.3 Retrieving marker and peak search results

CALCulate<n>:MARKer<m>:FUNCTion:FPEaks:SORT.....	111
CALCulate<n>:MARKer<m>:FUNCTion:FPEaks:X?.....	112
CALCulate<n>:MARKer<m>:FUNCTion:FPEaks:Y?.....	112
CALCulate<n>:DELTamarker<m>:X.....	112
CALCulate<n>:DELTamarker<m>:Y?.....	113
CALCulate<n>:MARKer<m>:X.....	113
CALCulate<n>:MARKer<m>:Y?.....	113
MMEMory:STORe<n>:LIST.....	114

CALCulate<n>:MARKer<m>:FUNCTion:FPEaks:SORT <SortMode>

Selects the order in which the results of a peak search are returned.

Suffix:

<n> [Window](#)

<m> [Marker](#)

Parameters:

<SortMode> **X**
Sorts the peaks according to increasing position on the x-axis.

Y
Sorts the peaks according to decreasing position on the y-axis.

*RST: X

Example:

CALC:MARK:FUNC:FPE:SORT Y

Sets the sort mode to decreasing y values

CALCulate<n>:MARKer<m>:FUNCTION:FPEaks:X?

Queries the position of the peaks on the x-axis.

The order depends on the sort order that has been set with [CALCulate<n>:MARKer<m>:FUNCTION:FPEaks:SORT](#).

Suffix:

<n> irrelevant

<m> irrelevant

Return values:

<PeakPosition> Position of the peaks on the x-axis. The unit depends on the measurement.

Usage: Query only

CALCulate<n>:MARKer<m>:FUNCTION:FPEaks:Y?

Queries the position of the peaks on the y-axis.

The order depends on the sort order that has been set with [CALCulate<n>:MARKer<m>:FUNCTION:FPEaks:SORT](#).

Suffix:

<n> irrelevant

<m> irrelevant

Return values:

<PeakPosition> Position of the peaks on the y-axis. The unit depends on the measurement.

Usage: Query only

CALCulate<n>:DELTamarker<m>:X <Position>

Moves a delta marker to a particular coordinate on the x-axis.

If necessary, the command activates the delta marker and positions a reference marker to the peak power.

Suffix:

<n> [Window](#)

<m> [Marker](#)

Parameters:

<Position> Numeric value that defines the marker position on the x-axis.

Range: The value range and unit depend on the measurement and scale of the x-axis.

Example:

`CALC:DELT:X?`

Outputs the absolute x-value of delta marker 1.

CALCulate<n>:DELTaMarker<m>:Y?

Queries the result at the position of the specified delta marker.

Suffix:

<n> 1..n

<m> 1..n

Return values:

<Result> Result at the position of the delta marker.
The unit is variable and depends on the one you have currently set.

Default unit: DBM

Usage: Query only

CALCulate<n>:MARKer<m>:X <Position>

Moves a marker to a specific coordinate on the x-axis.

If necessary, the command activates the marker.

If the marker has been used as a delta marker, the command turns it into a normal marker.

Suffix:

<n> [Window](#)

<m> [Marker](#)

Parameters:

<Position> Numeric value that defines the marker position on the x-axis.
The unit depends on the result display.

Range: The range depends on the current x-axis range.
Default unit: Hz

Example:

CALC:MARK2:X 1.7MHz

Positions marker 2 to frequency 1.7 MHz.

Manual operation: See ["Marker Table"](#) on page 21
See ["Marker Peak List"](#) on page 22

CALCulate<n>:MARKer<m>:Y?

Queries the result at the position of the specified marker.

Suffix:

<n> 1..n

<m> 1..n

Return values:

<Result> Default unit: DBM

Usage: Query only

Manual operation: See "Marker Table" on page 21
See "Marker Peak List" on page 22

MMEMory:STORe<n>:LIST <FileName>

Exports the SEM and spurious emission list evaluation to a file.

The file format is *.dat.

Suffix:

<n> [Window](#)

Parameters:

<FileName> String containing the path and name of the target file.

Example:

```
MMEM:STOR:LIST 'test'
```

Stores the current list evaluation results in the test.dat file.

8.6 Configuring I/Q analyzer measurements

• Configuring input sources	114
• Configuring outputs	119
• Configuring level characteristics	120
• Configuring the attenuator	122
• Configuring the preamplifier	123
• Scaling the Y-Axis	124
• Configuring the frequency	126
• Configuring trigger	128
• Configuring trigger output	133
• Configuring gated measurements	135
• Configuring data acquisition	137
• Automatic configuration	145
• Configuring the result display	148

8.6.1 Configuring input sources

INPut:ATTenuation:PROTection:RESet	115
INPut:COUPling	115
INPut:FILE:PATH	115
INPut:FILTer:HPASs[:STATe]	116
INPut:FILTer:YIG[:STATe]	117
INPut:IMPedance	117
INPut:IMPedance:PTYPE	117
INPut:SElect	118
INPut:UPORt:STATe	118
INPut:UPORt[:VALue]	118
TRACe:IQ:FILE:REPetition:COUNT	118

INPut:ATTenuation:PROTection:RESet

Resets the attenuator and reconnects the RF input with the input mixer for the R&S FSWP after an overload condition occurred and the protection mechanism intervened. The error status bit (bit 3 in the `STAT:QUES:POW` status register) and the `INPUT OVLD` message in the status bar are cleared.

The command works only if the overload condition has been eliminated first.

Example: `INP:ATT:PROT:RES`

INPut:COUPling <CouplingType>

Selects the coupling type of the RF input.

Parameters:

<CouplingType>	AC DC
	AC
	AC coupling
	DC
	DC coupling
	*RST: AC

Example: `INP:COUP DC`

Manual operation: See "[Input Coupling](#)" on page 47

INPut:FILE:PATH <FileName>[, <AnalysisBW>]

Selects the I/Q data file to be used as input for further measurements.

The I/Q data file must be in one of the following supported formats:

- `.iq.tar`
- `.iqw`
- `.csv`
- `.mat`
- `.wv`
- `.aid`

Only a single data stream or channel can be used as input, even if multiple streams or channels are stored in the file.

For some file formats that do not provide the sample rate and measurement time or record length, you must define these parameters manually. Otherwise the traces are not visible in the result displays.

For details, see [Table A-1](#).

Parameters:

<FileName> String containing the path and name of the source file. The file type is determined by the file extension. If no file extension is provided, the file type is assumed to be `.iq.tar`. For `.mat` files, Matlab® v4 is assumed.

<AnalysisBW> Optionally: The analysis bandwidth to be used by the measurement. The bandwidth must be smaller than or equal to the bandwidth of the data that was stored in the file.
Default unit: HZ

Example:

```
INP:FILE:PATH 'C:\R_S\Instr\user\data.iq.tar'
```

Uses I/Q data from the specified file as input.

Example:

```
//Load an IQW file
INP:SEL:FIQ
INP:FILE:PATH 'C:\R_S\Instr\user\data.iqw'
//Define the sample rate
TRAC:IQ:SRAT 10MHz
//Define the measurement time
SENSe:SWEp:TIME 0.001001
//Start the measurement
INIT:IMM
```

Manual operation: See "[Select I/Q data file](#)" on page 50

INPut:FILTer:HPASs[:STATe] <State>

Activates an additional internal high-pass filter for RF input signals from 1 GHz to 3 GHz. This filter is used to remove the harmonics of the R&S FSWP to measure the harmonics for a DUT, for example.

Requires an additional high-pass filter hardware option.

(Note: for RF input signals outside the specified range, the high-pass filter has no effect. For signals with a frequency of approximately 4 GHz upwards, the harmonics are suppressed sufficiently by the YIG-preselector, if available.)

Parameters:

<State> ON | OFF | 0 | 1
OFF | 0
 Switches the function off
ON | 1
 Switches the function on
***RST: 0**

Example:

```
INP:FILT:HPAS ON
```

Turns on the filter.

Manual operation: See "[High Pass Filter 1 to 3 GHz](#)" on page 48

INPut:FILTer:YIG[:STATE] <State>

Enables or disables the YIG filter.

Parameters:

<State> ON | OFF | 0 | 1
*RST: 0

Example: INP:FILT:YIG OFF
Deactivates the YIG-preselector.

Manual operation: See "YIG-Preselector" on page 48

INPut:IMPedance <Impedance>

Selects the nominal input impedance of the RF input. In some applications, only 50 Ω are supported.

Parameters:

<Impedance> 50 | 75
numeric value
User-defined impedance from 50 Ohm to 100000000 Ohm (=100 MOhm)
User-defined values are only available for the Spectrum application, the I/Q Analyzer, and some optional applications.
*RST: 50 Ω
Default unit: OHM

Example: INP:IMP 75

Manual operation: See "Impedance" on page 48
See "Unit" on page 54

INPut:IMPedance:PTYPe <PadType>

Defines the type of matching pad used for impedance conversion for RF input.

Parameters:

<PadType> SRESistor | MLPad
SRESistor
Series-R
MLPad
Minimum Loss Pad
*RST: SRESistor

Example: INP:IMP 100
INP:IMP:PTYP MLP

Manual operation: See "Impedance" on page 48

INPut:SElect <Source>

Selects the signal source for measurements, i.e. it defines which connector is used to input data to the R&S FSWP.

Parameters:

<Source> **RF**
Radio Frequency ("RF INPUT" connector)

FIQ
I/Q data file
(selected by [INPut:FILE:PATH](#) on page 115)

*RST: RF

Manual operation: See "[Radio Frequency State](#)" on page 47
 See "[I/Q Input File State](#)" on page 50

INPut:UPORt:STATe <State>

Toggles the control lines of the user ports for the **AUX PORT** connector. This SUB-D male connector is located on the rear panel of the R&S FSWP.

See the R&S FSWP Getting Started manual for details.

Parameters:

<State> **ON | 1**
User port is switched to INPut

OFF | 0
User port is switched to OUTPut

*RST: 1

INPut:UPORt[:VALue]

Queries the control lines of the user ports.

For details see [OUTPut:UPORt\[:VALue\]](#) on page 119.

Return values:

<Level> bit values in hexadecimal format
 TTL type voltage levels (max. 5V)
Range: #B00000000 to #B00111111

Example:

```
INP:UPOR?
//Result: #B00100100
Pins 5 and 7 are active.
```

TRACe:IQ:FILE:REPetition:COUNT <RepetitionCount>

Determines how often the data stream is repeatedly copied in the I/Q data memory. If the available memory is not sufficient for the specified number of repetitions, the largest possible number of complete data streams is used.

Parameters:

<RepetitionCount> integer

Example:

TRAC:IQ:FILE:REP:COUN 3

8.6.2 Configuring outputs

DIAGnostic:SERvice:NSOource.....	119
OUTPut:UPORt[:VALue].....	119
OUTPut:UPORt:STATe.....	120

DIAGnostic:SERvice:NSOource <State>

Turns the 28 V supply of the BNC connector labeled [noise source control] on the R&S FSWP on and off.

Parameters:

<State> ON | OFF | 0 | 1
OFF | 0
 Switches the function off
ON | 1
 Switches the function on

Example:

DIAG:SERV:NSO ON

Manual operation: See "[Noise Source Control](#)" on page 51**OUTPut:UPORt[:VALue] <Value>**

Sets the control lines of the user ports.

The assignment of the pin numbers to the bits is as follows:

Bit	7	6	5	4	3	2	1	0
Pin	N/A	N/A	19	18	17	16	15	14

Bits 7 and 6 are not assigned to pins and must always be 0.

The user port is written to with the given binary pattern.

If the user port is programmed to input instead of output (see [INPut:UPORt:STATe](#) on page 118), the output value is temporarily stored.

Parameters:

<Value> bit values in hexadecimal format
 TTL type voltage levels (max. 5V)
 Range: #B00000000 to #B00111111

Example:

OUTP:UPOR #B00100100
 Sets pins 5 and 7 to 5 V.

OUTPut:UPORt:STATe <State>

Toggles the control lines of the user ports for the **AUX PORT** connector. This 9-pole SUB-D male connector is located on the rear panel of the R&S FSWP.

Parameters:

<State> ON | OFF | 0 | 1
 OFF | 0
 User port is switched to INPut
 ON | 1
 User port is switched to OUTPut

Example: OUTP:UPOR:STAT ON

8.6.3 Configuring level characteristics

Commands useful to configure level characteristics described elsewhere:

- [\[SENSe:\]ADJust:LEVel](#) on page 148

CALCulate<n>:MARKer<m>:FUNction:REFerence	120
CALCulate<n>:UNIT:POWER	120
DISPlay[:WINDow<n>][:SUBWindow<w>]:TRACe<t>:Y[:SCALe]:RLEVel	121
DISPlay[:WINDow<n>][:SUBWindow<w>]:TRACe<t>:Y[:SCALe]:RLEVel:OFFSet	121
[SENSe:]POWER:NCORrection	122

CALCulate<n>:MARKer<m>:FUNction:REFerence

Matches the reference level to the power level of a marker.

If you use the command in combination with a delta marker, that delta marker is turned into a normal marker.

Suffix:

<n> Window
 <m> Marker

Example: CALC:MARK2:FUNC:REF
 Sets the reference level to the level of marker 2.

CALCulate<n>:UNIT:POWER <Unit>

Selects the power unit.

The unit applies to all power-based measurement windows with absolute values.

In addition, the unit of the reference level is adapted to the same unit.

Suffix:

<n> irrelevant

Parameters:

<Unit> DBM | V | A | W | DBPW | WATT | DBUV | DBMV | VOLT |
 DBUA | AMPere
 *RST: dBm

Example:

CALC:UNIT:POW DBM
 Sets the power unit to dBm.

Manual operation: See "[Unit](#)" on page 54

DISPlay[:WINDow<n>][:SUBWindow<w>]:TRACe<t>:Y[:SCALe]:RLEVel
 <ReferenceLevel>

Defines the reference level (for all traces in all windows).

With a reference level offset $\neq 0$, the value range of the reference level is modified by the offset.

Suffix:

<n> irrelevant
 <w> subwindow
 Not supported by all applications
 <t> irrelevant

Parameters:

<ReferenceLevel> The unit is variable.
 Range: see specifications document
 *RST: 0 dBm
 Default unit: DBM

Example: DISP:TRAC:Y:RLEV -60dBm

Manual operation: See "[Reference Level](#)" on page 54

DISPlay[:WINDow<n>][:SUBWindow<w>]:TRACe<t>:Y[:SCALe]:RLEVel:OFFSet
 <Offset>

Defines a reference level offset (for all traces in all windows).

Suffix:

<n> irrelevant
 <w> subwindow
 Not supported by all applications
 <t> irrelevant

Parameters:

<Offset> Range: -200 dB to 200 dB
 *RST: 0dB
 Default unit: DB

Example: DISP:TRAC:Y:RLEV:OFFS -10dB

Manual operation: See ["Shifting the Display \(Offset\)"](#) on page 54

[SENSe:]POWer:NCORrection <State>

Turns noise cancellation on and off.

If noise cancellation is on, the R&S FSWP performs a reference measurement to determine its inherent noise and subtracts the result from the channel power measurement result (first active trace only).

For more information see ["Noise Cancellation"](#) on page 56.

Parameters:

<State> ON | OFF | 1 | 0
 *RST: 0

Example: POW:NCOR ON

Manual operation: See ["Noise Cancellation"](#) on page 56

8.6.4 Configuring the attenuator

INPut:ATTenuation	122
INPut:ATTenuation:AUTO	122
INPut:ATTenuation:AUTO:MODE	123

INPut:ATTenuation <Attenuation>

Defines the total attenuation for RF input.

If you set the attenuation manually, it is no longer coupled to the reference level, but the reference level is coupled to the attenuation. Thus, if the current reference level is not compatible with an attenuation that has been set manually, the command also adjusts the reference level.

Parameters:

<Attenuation> Range: see specifications document
 Increment: 5 dB (with optional electr. attenuator: 1 dB)
 *RST: 10 dB (AUTO is set to ON)
 Default unit: DB

Example: INP:ATT 30dB
 Defines a 30 dB attenuation and decouples the attenuation from the reference level.

Manual operation: See ["Attenuation Mode / Value"](#) on page 55

INPut:ATTenuation:AUTO <State>

Couples or decouples the attenuation to the reference level. Thus, when the reference level is changed, the R&S FSWP determines the signal level for optimal internal data processing and sets the required attenuation accordingly.

Parameters:

<State> ON | OFF | 0 | 1
 *RST: 1

Example:

INP:ATT:AUTO ON
 Couples the attenuation to the reference level.

Manual operation: See "[Attenuation Mode / Value](#)" on page 55

INPut:ATTenuation:AUTO:MODE <OptMode>

Selects the priority for signal processing *after* the RF attenuation has been applied.

Parameters:

<OptMode> LNOise | LDISTortion

LNOise

Optimized for high sensitivity and low noise levels

LDISTortion

Optimized for low distortion by avoiding intermodulation

*RST: LDISTortion (WLAN application: LNOise)

Example:

INP:ATT:AUTO:MODE LNO

Manual operation: See "[Optimization](#)" on page 55

8.6.5 Configuring the preamplifier

INPut:GAIN:STATe	123
INPut:GAIN[:VALue]	124

INPut:GAIN:STATe <State>

Turns the internal preamplifier on and off. It requires the optional preamplifier hardware.

The preamplification value is defined using the [INPut:GAIN\[:VALue\]](#) on page 124.

Parameters:

<State> ON | OFF | 0 | 1
OFF | 0
 Switches the function off
ON | 1
 Switches the function on
 *RST: 0

Example:

INP:GAIN:STAT ON
 INP:GAIN:VAL 15
 Switches on 15 dB preamplification.

Manual operation: See "[Preamplifier](#)" on page 56

INPut:GAIN[:VALue] <Gain>

Selects the "gain" if the preamplifier is activated (INP:GAIN:STAT ON, see INPut:GAIN:STATe on page 123).

The command requires the additional preamplifier hardware option.

Parameters:

<Gain> For R&S FSWP models 1322.8003K08, 1322.8003K09, 1322.8003K27 and 1322.8003K51, the following settings are available:
15 dB and 30 dB
All other values are rounded to the nearest of these two.
For R&S FSWP models 1322.8003K26 and 1322.8003K50:
30 dB
Default unit: DB

Example: INP:GAIN:STAT ON
INP:GAIN:VAL 30
Switches on 30 dB preamplification.

Manual operation: See "Preamplifier" on page 56

8.6.6 Scaling the Y-Axis

DISPlay[:WINDow<n>][:SUBWindow<w>]:TRACe<t>:Y[:SCALe].....	124
DISPlay[:WINDow<n>][:SUBWindow<w>]:TRACe<t>:Y[:SCALe]:AUTO ONCE.....	125
DISPlay[:WINDow<n>][:SUBWindow<w>]:TRACe<t>:Y[:SCALe]:MODE.....	125
DISPlay[:WINDow<n>][:SUBWindow<w>]:TRACe<t>:Y[:SCALe]:RPOSition.....	125
DISPlay[:WINDow<n>][:SUBWindow<w>]:TRACe<t>:Y:SPACing.....	126

DISPlay[:WINDow<n>][:SUBWindow<w>]:TRACe<t>:Y[:SCALe] <Range>

Defines the display range of the y-axis (for all traces).

Note that the command works only for a logarithmic scaling. You can select the scaling with DISPlay[:WINDow<n>][:SUBWindow<w>]:TRACe<t>:Y:SPACing.

Suffix:

<n> Window
<w> subwindow
Not supported by all applications
<t> irrelevant

Parameters:

<Range> Range: 1 dB to 200 dB
*RST: 100 dB
Default unit: HZ

Example: DISP:TRAC:Y 110dB

Manual operation: See "Range" on page 57
See "Y-Axis Max" on page 58

DISPlay[:WINDow<n>][:SUBWindow<w>]:TRACe<t>:Y[:SCALe]:AUTO ONCE

Automatic scaling of the y-axis is performed once, then switched off again (for all traces).

Suffix:

<n> [Window](#)

<t> irrelevant

Manual operation: See "Auto Scale Once" on page 57

DISPlay[:WINDow<n>][:SUBWindow<w>]:TRACe<t>:Y[:SCALe]:MODE <Mode>

Selects the type of scaling of the y-axis (for all traces).

When the display update during remote control is off, this command has no immediate effect.

Suffix:

<n> [Window](#)

<w> subwindow

<t> irrelevant

Parameters:

<Mode> **ABSolute**
absolute scaling of the y-axis

RELative
relative scaling of the y-axis

*RST: ABSolute

Example: DISP:TRAC:Y:MODE REL

Manual operation: See "Scaling" on page 58

**DISPlay[:WINDow<n>][:SUBWindow<w>]:TRACe<t>:Y[:SCALe]:RPOSition
<Position>**

Defines the vertical position of the reference level on the display grid (for all traces).

The R&S FSWP adjusts the scaling of the y-axis accordingly.

For measurements with the optional external generator control, the command defines the position of the reference value.

Suffix:

<n> [Window](#)

<w> subwindow
Not supported by all applications

<t> irrelevant

Parameters:

<Position> 0 PCT corresponds to the lower display border, 100% corresponds to the upper display border.
 *RST: 100 PCT = frequency display; 50 PCT = time display
 Default unit: PCT

Example: DISP:TRAC:Y:RPOS 50PCT

Manual operation: See "Ref Level Position" on page 57

DISPlay[:WINDow<n>][:SUBWindow<w>]:TRACe<t>:Y:SPACing <ScalingType>

Selects the scaling of the y-axis (for all traces, <t> is irrelevant).

Suffix:

<n> [Window](#)

<w> subwindow

<t> [Trace](#)

Parameters:

<ScalingType> **LOGarithmic**
 Logarithmic scaling.
LINear
 Linear scaling in %.
LDB
 Linear scaling in the specified unit.
PERCent
 Linear scaling in %.
 *RST: LOGarithmic

Example: DISP:TRAC:Y:SPAC LIN
 Selects linear scaling in %.

Manual operation: See "Scaling" on page 58

8.6.7 Configuring the frequency

CALCulate<n>:MARKer<m>:FUNCTion:CENTer	126
[SENSe:]FREQUency:CENTer	127
[SENSe:]FREQUency:CENTer:STEP	127
[SENSe:]FREQUency:CENTer:STEP:AUTO	128
[SENSe:]FREQUency:OFFSet	128

CALCulate<n>:MARKer<m>:FUNCTion:CENTer

Matches the center frequency to the frequency of a marker.

If you use the command in combination with a delta marker, that delta marker is turned into a normal marker.

Suffix:

<n> [Window](#)

<m> [Marker](#)

Example:

```
CALC:MARK2:FUNC:CENT
```

Sets the center frequency to the frequency of marker 2.

[SENSe:]FREQuency:CENTer <Frequency>

Defines the center frequency.

CW, pulsed and VCO measurements:

This command defines or queries (in case of automatic frequency search) the current signal frequency.

Transient measurement:

This command defines the center frequency of the transient measurement.

Parameters:

<Frequency> For the allowed range and f_{max} , refer to the specifications document.

*RST: $f_{max}/2$

Default unit: Hz

Example:

```
FREQ:CENT 100 MHz
```

```
FREQ:CENT:STEP 10 MHz
```

```
FREQ:CENT UP
```

Sets the center frequency to 110 MHz.

Manual operation: See "[Center Frequency](#)" on page 59

[SENSe:]FREQuency:CENTer:STEP <StepSize>

Defines the center frequency step size.

You can increase or decrease the center frequency quickly in fixed steps using the `SENS:FREQ UP AND SENS:FREQ DOWN` commands, see [\[SENSe:\]FREQuency:CENTer](#) on page 127.

Parameters:

<StepSize> For f_{max} , refer to the specifications document.

Range: 1 to f_{MAX}

*RST: 0.1 x span

Default unit: Hz

Example:

```
//Set the center frequency to 110 MHz.
```

```
FREQ:CENT 100 MHz
```

```
FREQ:CENT:STEP 10 MHz
```

```
FREQ:CENT UP
```

Manual operation: See "[Center Frequency Stepsize](#)" on page 59

[SENSe:]FREQuency:CENTer:STEP:AUTO <State>

Couples or decouples the center frequency step size to the span.

In time domain (zero span) measurements, the center frequency is coupled to the RBW.

Parameters:

<State> ON | OFF | 0 | 1
 *RST: 1

Example:

FREQ:CENT:STEP:AUTO ON
 Activates the coupling of the step size to the span.

[SENSe:]FREQuency:OFFSet <Offset>

Defines a frequency offset.

If this value is not 0 Hz, the application assumes that the input signal was frequency shifted outside the application. All results of type "frequency" will be corrected for this shift numerically by the application.

See also "[Frequency Offset](#)" on page 59.

Note: In MSRA mode, the setting command is only available for the MSRA primary application. For MSRA secondary applications, only the query command is available.

Parameters:

<Offset> Range: -1 THz to 1 THz
 *RST: 0 Hz
 Default unit: HZ

Example:

FREQ:OFFS 1GHZ

Manual operation: See "[Frequency Offset](#)" on page 59

8.6.8 Configuring trigger



*OPC should be used after requesting data. This will hold off any subsequent changes to the selected trigger source, until after the sweep is completed and the data is returned.

TRIGger[:SEQuence]:DTIME.....	129
TRIGger[:SEQuence]:HOLDoff[:TIME].....	129
TRIGger[:SEQuence]:IFPower:HOLDoff.....	129
TRIGger[:SEQuence]:IFPower:HYSTeresis.....	130
TRIGger[:SEQuence]:LEVel[:EXTernal<port>].....	130
TRIGger[:SEQuence]:LEVel:IFPower.....	130
TRIGger[:SEQuence]:LEVel:IQPower.....	131

TRIGger[:SEQuence]:LEVel:RFPower.....	131
TRIGger[:SEQuence]:SLOPe.....	131
TRIGger[:SEQuence]:SOURce.....	132
TRIGger[:SEQuence]:TIME:RINTerval.....	133

TRIGger[:SEQuence]:DTIME <DropoutTime>

Defines the time the input signal must stay below the trigger level before a trigger is detected again.

Parameters:

<DropoutTime> Dropout time of the trigger.
 Range: 0 s to 10.0 s
 *RST: 0 s
 Default unit: S

Manual operation: See "[Drop-Out Time](#)" on page 64

TRIGger[:SEQuence]:HOLDoff[:TIME] <Offset>

Defines the time offset between the trigger event and the start of the measurement.

Parameters:

<Offset> For measurements in the frequency domain, the range is 0 s to 30 s.
 For measurements in the time domain, the range is the negative measurement time to 30 s.
 *RST: 0 s
 Default unit: S

Example: TRIG:HOLD 500us

Manual operation: See "[Trigger Offset](#)" on page 63

TRIGger[:SEQuence]:IFPower:HOLDoff <Period>

Defines the holding time before the next trigger event.

Note that this command can be used for **any trigger source**, not just IF Power (despite the legacy keyword).

Note: If you perform gated measurements in combination with the IF Power trigger, the R&S FSWP ignores the holding time for frequency sweep, FFT sweep, zero span and I/Q data measurements.

Parameters:

<Period> Range: 0 s to 10 s
 *RST: 0 s
 Default unit: S

Example: TRIG:SOUR EXT
Sets an external trigger source.
TRIG:IFP:HOLD 200 ns
Sets the holding time to 200 ns.

Manual operation: See ["Trigger Holdoff"](#) on page 64

TRIGger[:SEQuence]:IFPower:HYSTeresis <Hysteresis>

Defines the trigger hysteresis, which is only available for "IF Power" trigger sources.

Parameters:

<Hysteresis> Range: 3 dB to 50 dB
 *RST: 3 dB
 Default unit: DB

Example: TRIG:SOUR IFP
Sets the IF power trigger source.
TRIG:IFP:HYST 10DB
Sets the hysteresis limit value.

Manual operation: See ["Hysteresis"](#) on page 63

TRIGger[:SEQuence]:LEVel[:EXTernal<port>] <TriggerLevel>

Defines the level the external signal must exceed to cause a trigger event.

In the I/Q Analyzer, only EXTERNAL1 is supported.

Suffix:

<port> Selects the trigger port.
 1 = trigger port 1 (TRIGGER INPUT connector on front panel)
 2 = trigger port 2 (TRIGGER INPUT/OUTPUT connector on rear panel)

Parameters:

<TriggerLevel> Range: 0.5 V to 3.5 V
 *RST: 1.4 V
 Default unit: V

Example: TRIG:LEV 2V

Manual operation: See ["Trigger Level"](#) on page 63

TRIGger[:SEQuence]:LEVel:IFPower <TriggerLevel>

Defines the power level at the third intermediate frequency that must be exceeded to cause a trigger event.

Note that any RF attenuation or preamplification is considered when the trigger level is analyzed. If defined, a reference level offset is also considered.

Parameters:

<TriggerLevel> For details on available trigger levels and trigger bandwidths, see the specifications document.

*RST: -20 dBm
Default unit: DBM

Example:

TRIG:LEV:IFP -30DBM

Manual operation: See "[Trigger Level](#)" on page 63

TRIGger[:SEQuence]:LEVel:IQPower <TriggerLevel>

Defines the magnitude the I/Q data must exceed to cause a trigger event.

Note that any RF attenuation or preamplification is considered when the trigger level is analyzed. If defined, a reference level offset is also considered.

Parameters:

<TriggerLevel> Range: -130 dBm to 30 dBm
*RST: -20 dBm
Default unit: DBM

Example:

TRIG:LEV:IQP -30DBM

Manual operation: See "[Trigger Level](#)" on page 63

TRIGger[:SEQuence]:LEVel:RFPower <TriggerLevel>

Defines the power level the RF input must exceed to cause a trigger event. Note that any RF attenuation or preamplification is considered when the trigger level is analyzed. If defined, a reference level offset is also considered.

The input signal must be between 500 MHz and 8 GHz.

Parameters:

<TriggerLevel> For details on available trigger levels and trigger bandwidths, see the specifications document.

*RST: -20 dBm
Default unit: DBM

Example:

TRIG:LEV:RFP -30dBm

Manual operation: See "[Trigger Level](#)" on page 63

TRIGger[:SEQuence]:SLOPe <Type>

Selects the trigger slope.

Parameters:

<Type> POSitive | NEGative

POSitive

Triggers when the signal rises to the trigger level (rising edge).

NEGative

Triggers when the signal drops to the trigger level (falling edge).

*RST: POSitive

Example: TRIG:SLOP NEG

Manual operation: See ["Slope"](#) on page 64

TRIGger[:SEQUence]:SOURce <Source>

Selects the trigger source.

For details on trigger sources, see ["Trigger Source"](#) on page 61.

Note on external triggers:

If a measurement is configured to wait for an external trigger signal in a remote control program, remote control is blocked until the trigger is received and the program can continue. Make sure that this situation is avoided in your remote control programs.

Parameters:

<Source>

IMMediate

Free Run

EXT | EXT2

Trigger signal from one of the "Trigger Input/Output" connectors.

Note: Connector must be configured for "Input".

RFPower

First intermediate frequency

(Frequency and time domain measurements only.)

IFPower

Second intermediate frequency

IQPower

Magnitude of sampled I/Q data

For applications that process I/Q data, such as the I/Q Analyzer or optional applications.

VIDeo

Video mode is available in the time domain and only in the Spectrum application.

*RST: IMMediate

Example: TRIG:SOUR EXT

Selects the external trigger input as source of the trigger signal

Manual operation: See ["Trigger Source"](#) on page 61
 See ["Free Run"](#) on page 61
 See ["Ext. Trigger 1/2"](#) on page 61
 See ["IF Power"](#) on page 62
 See ["I/Q Power"](#) on page 62
 See ["RF Power"](#) on page 62
 See ["Time"](#) on page 63

TRIGger[:SEQuence]:TIME:RINTerval <Interval>

Defines the repetition interval for the time trigger.

Parameters:

<Interval> numeric value
 Range: 2 ms to 5000 s
 *RST: 1.0 s
 Default unit: S

Example:

TRIG:SOUR TIME
 Selects the time trigger input for triggering.
 TRIG:TIME:RINT 5
 The measurement starts every 5 s.

Manual operation: See "[Repetition Interval](#)" on page 63

8.6.9 Configuring trigger output

OUTPut:TRIGger<tp>:DIRection	133
OUTPut:TRIGger<tp>:LEVel	133
OUTPut:TRIGger<tp>:OTYPe	134
OUTPut:TRIGger<tp>:PULSe:IMMediate	134
OUTPut:TRIGger<tp>:PULSe:LENGth	135

OUTPut:TRIGger<tp>:DIRection <Direction>

Selects the trigger direction for trigger ports that serve as an input as well as an output.

Suffix:

<tp> Selects the used trigger port.
 <2>: selects trigger port 2 (on the rear panel).

Parameters:

<Direction> INPut | OUTPut
 INPut
 Port works as an input.
 OUTPut
 Port works as an output.
 *RST: INPut

Manual operation: See "[Trigger 1/2](#)" on page 51

OUTPut:TRIGger<tp>:LEVel <Level>

Defines the level of the (TTL compatible) signal generated at the trigger output.

Works only if you have selected a user-defined output with [OUTPut:TRIGger<tp>:OTYPe](#).

Suffix:

<tp> 1..n
 Selects the trigger port to which the output is sent.
 2 = trigger port 2 (rear)

Parameters:

<Level> **HIGH**
 5 V
LOW
 0 V
 *RST: LOW

Example: OUTP:TRIG2:LEV HIGH

Manual operation: See "[Level](#)" on page 52

OUTPut:TRIGger<tp>:OTYPe <OutputType>

Selects the type of signal generated at the trigger output.

Suffix:

<tp> 1..n
 Selects the trigger port to which the output is sent.
 2 = trigger port 2 (rear)

Parameters:

<OutputType> **DEvice**
 Sends a trigger signal when the R&S FSWP has triggered internally.

TARMed
 Sends a trigger signal when the trigger is armed and ready for an external trigger event.

UDEFineD
 Sends a user-defined trigger signal. For more information, see [OUTPut:TRIGger<tp>:LEVel](#).

*RST: DEvice

Manual operation: See "[Output Type](#)" on page 52

OUTPut:TRIGger<tp>:PULSe:IMMediate

Generates a pulse at the trigger output.

Suffix:

<tp> 1..n
 Selects the trigger port to which the output is sent.
 2 = trigger port 2 (rear)

Manual operation: See "[Send Trigger](#)" on page 52

OUTPut:TRIGger<tp>:PULSe:LENGth <Length>

Defines the length of the pulse generated at the trigger output.

Suffix:

<tp> Selects the trigger port to which the output is sent.
2 = trigger port 2 (rear)

Parameters:

<Length> Pulse length in seconds.
Default unit: S

Example: OUTP:TRIG2:PULS:LENG 0.02

Manual operation: See "Pulse Length" on page 52

8.6.10 Configuring gated measurements

Usually in spectrum analysis, measurements are based on a certain length of time called the gate area. With I/Q gating, you can define the gate area using the gate length, the distance between the capture periods and the number of periods. The gate length and the distance between the capture periods are specified in samples.



I/Q gating is only available using remote commands; manual configuration is not possible.

Using I/Q gating, the gate area can be defined using the following methods:

- Edge triggered capturing
After a trigger signal, the gate period is defined by a gate length and a gate distance. All data in the gate period is captured until the required number of samples has been captured.

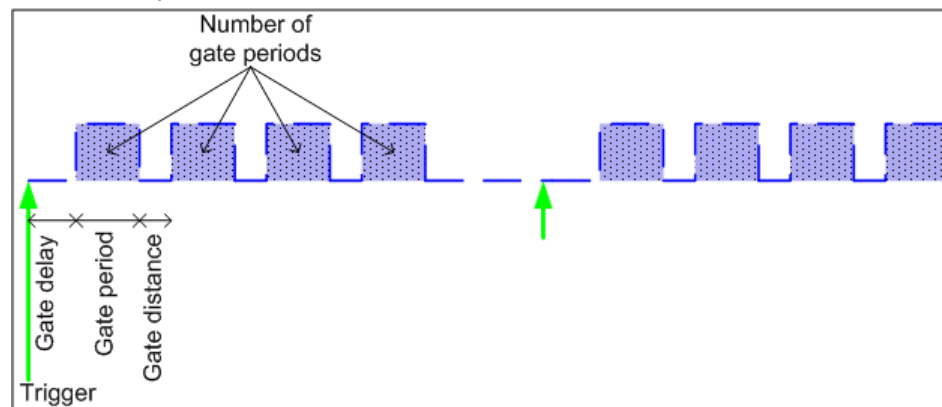

- Level triggered capturing
After a trigger signal, all data is captured in which the gate signal is set to 1, which means it has exceeded a level. In this case, the gate signal can be generated by the IFP trigger, for example: each time the IFP level is exceeded, the IFP trigger signal is set to 1 and the samples in this area are captured as gate samples.

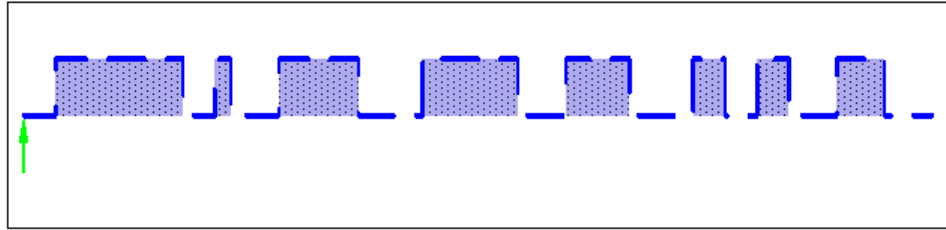

The number of complex samples to be captured prior to the trigger event can be selected (see [TRACe:IQ:SET](#) on page 142) for all available trigger sources, except for "Free Run".

TRACe:IQ:EGATe[:STATe] <State>

Turns gated measurements with the I/Q analyzer on and off.

Before you can use the command you have to turn on the I/Q analyzer and select an external or IF power trigger source.

Parameters:

<State> ON | OFF

Example: TRAC:IQ:EGAT ON

TRACe:IQ:EGATe:GAP <Samples>

Defines the interval between several gate periods for gated measurements with the I/Q analyzer.

Parameters:

<Samples> <numeric value>

Max = (440 MS * sample rate/200MHz) -1
pretrigger samples defined by [TRACe:IQ:SET](#);
sample rate defined by [TRACe:IQ:SRATe](#))

Range: 1...Max (samples)

*RST: 1

Example: TRAC:IQ:EGAT:GAP 2

TRACe:IQ:EGATe:LENGth <GateLength>

Defines the gate length for gated measurements with the I/Q analyzer.

Parameters:

<GateLength> <numeric value>

Max = (440 MS * sample rate/200MHz) -1
pretrigger samples defined by [TRACe:IQ:SET](#);
sample rate defined by [TRACe:IQ:SRATe](#))

Range: 1...Max (samples)

*RST: 100

Example: TRAC:IQ:EGAT:LENG 2000

TRACe:IQ:EGATe:NOF <Number>

Defines the number of gate periods after the trigger signal for gated measurements with the I/Q analyzer.

Parameters:

<Number> Range: 1 to 1023
 *RST: 1

Example: TRAC:IQ:EGAT:NOF 2

TRACe:IQ:EGATe:TYPE <Type>

Selects the gate mode for gated measurements with the I/Q analyzer.

Note: The IF power trigger holdoff time is ignored if you are using the "Level" gate mode in combination with an IF Power trigger.

Parameters:

<Type> **LEVEl**
 EDGE
 *RST: EDGE

Example: TRAC:IQ:EGAT:TYPE LEV

8.6.11 Configuring data acquisition

Useful commands for I/Q data acquisition described elsewhere

- [SENSe:]SWEep:COUNT on page 100
- [SENSe:]SWEep[:WINDow<n>]:POINTs on page 101
- [SENSe:]SWEep:TIME on page 101

[SENSe:]IQ:BWIDth:MODE.....	138
[SENSe:]IQ:BWIDth:RESolution.....	138
[SENSe:]IQ:FFT:ALGORITHM.....	139
[SENSe:]IQ:FFT:LENGth.....	139
[SENSe:]IQ:FFT:WINDow:LENGth.....	139
[SENSe:]IQ:FFT:WINDow:OVERlap.....	140
[SENSe:]IQ:FFT:WINDow:TYPE.....	140
[SENSe:]MSRA:CAPTure:OFFSet.....	140
[SENSe:]SWAPiq.....	141
TRACe:IQ:BWIDth.....	141
TRACe:IQ:RLENGth.....	141
TRACe:IQ:SET.....	142
TRACe:IQ:SRATe.....	143
TRACe:IQ:TPISample?.....	144
TRACe:IQ:WBANd:MBWidth.....	144
TRACe:IQ:WBANd[:STATe].....	145
TRACe:IQ:WFILter.....	145

[SENSe:]IQ:BWIDth:MODE <Mode>

Defines how the resolution bandwidth is determined.

Parameters:

<Mode>

AUTO | MANual | FFT

AUTO

(Default) The RBW is determined automatically depending on the sample rate and record length.

MANual

The user-defined RBW is used and the (FFT) window length (and possibly the sample rate) are adapted accordingly. The RBW is defined using the `[SENSe:]IQ:BWIDth:RESolution` command.

FFT

The RBW is determined by the FFT parameters.

*RST: AUTO

Example:

```
IQ:BAND:MODE MAN
```

Switches to manual RBW mode.

```
IQ:BAND:RES 120000
```

Sets the RBW to 120 kHz.

Manual operation: See "[RBW](#)" on page 68

[SENSe:]IQ:BWIDth:RESolution <Bandwidth>

Defines the resolution bandwidth manually if `[SENSe:]IQ:BWIDth:MODE` is set to MAN.

Defines the resolution bandwidth. The available RBW values depend on the sample rate and record length.

For details see [Section 4.5.4, "Frequency resolution of FFT results - RBW"](#), on page 36.

Parameters:

<Bandwidth>

refer to specifications document

*RST: RBW: AUTO mode is used

Default unit: HZ

Example:

```
IQ:BAND:MODE MAN
```

Switches to manual RBW mode.

```
IQ:BAND:RES 120000
```

Sets the RBW to 120 kHz.

Manual operation: See "[RBW](#)" on page 68

[SENSe:]IQ:FFT:ALGORITHM <Method>

Defines the FFT calculation method.

Parameters:

<Method>

SINGLE

One FFT is calculated for the entire record length; if the FFT length is larger than the record length (see [\[SENSe:\]IQ:FFT:LENGTH](#) and [TRACe:IQ:RLENGth](#)), zeros are appended to the captured data.

AVERAGE

Several overlapping FFTs are calculated for each record; the results are averaged to determine the final FFT result for the record.

The user-defined window length and window overlap are used. See [\[SENSe:\]IQ:FFT:WINDOW:LENGTH](#) and [\[SENSe:\]IQ:FFT:WINDOW:OVERlap](#).

*RST: AVER

Example: IQ:FFT:ALG SING

Manual operation: See "[Transformation Algorithm](#)" on page 68

[SENSe:]IQ:FFT:LENGTH <NoOfBins>

Defines the number of frequency points determined by each FFT calculation. The more points are used, the higher the resolution in the spectrum becomes, but the longer the calculation takes.

Parameters:

<NoOfBins>

integer value

Range: 3 to 524288

*RST: 4096

Example: IQ:FFT:LENG 2048

Manual operation: See "[FFT Length](#)" on page 69

[SENSe:]IQ:FFT:WINDOW:LENGTH <NoOfFFT>

Defines the number of samples to be included in a single FFT window when multiple FFT windows are used.

Parameters:

<NoOfFFT>

integer value

Range: 3 to 4096

*RST: record length

Example: IQ:FFT:WIND:LENG 500

Manual operation: See "[Window Length](#)" on page 69

[SENSe:]IQ:FFT:WINDow:OVERlap <Rate>

Defines the part of a single FFT window that is re-calculated by the next FFT calculation.

Parameters:

<Rate> double value
 Percentage rate
 Range: 0 to 1
 *RST: 0.75

Example:

`IQ:FFT:WIND:OVER 0.5`

Half of each window overlaps the previous window in FFT calculation.

Manual operation: See "[Window Overlap](#)" on page 69

[SENSe:]IQ:FFT:WINDow:TYPE <Function>

In the I/Q Analyzer you can select one of several FFT window types.

Parameters:

<Function> **BLACKharris**
 Blackman-Harris
 FLATtop
 Flattop
 GAUSSian
 Gauss
 RECTangular
 Rectangular
 P5
 5-Term
 *RST: FLAT

Example:

`IQ:FFT:WIND:TYPE GAUS`

Manual operation: See "[Window Function](#)" on page 69

[SENSe:]MSRA:CAPTure:OFFSet <Offset>

This setting is only available for secondary applications in MSRA mode, not for the MSRA primary application. It has a similar effect as the trigger offset in other measurements.

Parameters:

<Offset>

This parameter defines the time offset between the capture buffer start and the start of the extracted secondary application data. The offset must be a positive value, as the secondary application can only analyze data that is contained in the capture buffer.

Range: 0 to <Record length>

*RST: 0

Default unit: S

Manual operation: See "[Capture Offset](#)" on page 70**[SENSe:]SWAPiq <State>**

Defines whether or not the recorded I/Q pairs should be swapped (I<->Q) before being processed. Swapping I and Q inverts the sideband.

This is useful if the DUT interchanged the I and Q parts of the signal; then the R&S FSWP can do the same to compensate for it.

Parameters:

<State>

ON | 1

I and Q signals are interchanged

Inverted sideband, $Q+jI$ **OFF | 0**

I and Q signals are not interchanged

Normal sideband, $I+jQ$

*RST: 0

Manual operation: See "[Swap I/Q](#)" on page 67**TRACe:IQ:BWIDth**

Defines or queries the bandwidth of the resampling filter.

The bandwidth of the resampling filter depends on the sample rate.

Parameters:

<Bandwidth>

For details on the maximum bandwidth see [Section 4.1.1, "Sample rate and maximum usable I/Q bandwidth for RF input"](#), on page 25.

Default unit: HZ

Manual operation: See "[Analysis Bandwidth](#)" on page 66**TRACe:IQ:RLENgth <NoOfSamples>**

Sets the record length for the acquired I/Q data.

Increasing the record length also increases the measurement time.

Note: Alternatively, you can define the measurement time using the `SENS:SWE:TIME` command.

Parameters:

<NoOfSamples> Number of samples to record.
 See [Section 4.1.1, "Sample rate and maximum usable I/Q bandwidth for RF input"](#), on page 25.
 *RST: 1001

Example: `TRAC:IQ:RLEN 256`

Manual operation: See ["Record Length"](#) on page 67

TRACe:IQ:SET <NORM>, <0>, <SampleRate>, <TriggerMode>, <TriggerSlope>, <PretriggerSamp>, <NumberSamples>

Sets up the R&S FSWP for I/Q measurements.

If you do not use this command to set up I/Q measurements, the R&S FSWP will use its current settings for I/Q measurements.

If the I/Q Analyzer has not been turned on previously, the command also switches to the I/Q Analyzer.

Note: If you use the default settings with `TRACe:IQ:DATA??`, the following minimum buffer sizes for the response data are recommended:

ASCII format: 10 kBytes

Binary format: 2 kBytes

Parameters:

<NORM> This value is always `NORM`.

<0> Default unit: HZ
 This value is always 0.

<SampleRate> Sample rate for the data acquisition.
 Range: 100 Hz to 20 GHz, continuously adjustable
 *RST: 32000000
 Default unit: HZ

<TriggerMode> Selection of the trigger source used for the measurement.
IMMediate | **EXT**ernal | **EXT**2 | **EXT**3 | **IF**Power
 For IMM mode, gating is automatically deactivated.
 *RST: IMM

<TriggerSlope> Used trigger slope.
POSitive | **NEG**ative
 *RST: POS

<PretriggerSamp> Defines the trigger offset in terms of pretrigger samples. Negative values correspond to a trigger delay. This value also defines the interval between the trigger signal and the gate edge in samples.

Range: -1399999999 to 1399999999

*RST: 0

<NumberSamples> Number of measurement values to record (including the pretrigger samples).

See [Section 4.1.1, "Sample rate and maximum usable I/Q bandwidth for RF input"](#), on page 25.

*RST: 1001

Example:

```
TRAC:IQ:SET NORM,0,32MHz,EXT,POS,0,2048
```

Reads 2048 I/Q-values starting at the trigger point.

sample rate = 32 MHz

trigger = External

slope = Positive

```
TRAC:IQ:SET NORM,0,4 MHz,EXT,POS,1024,512
```

Reads 512 I/Q-values from 1024 measurement points before the trigger point.

filter type = NORMAL

sample rate = 4 MHz

trigger = External

slope = Positive

Manual operation: See ["Record Length"](#) on page 67

TRACe:IQ:SRATe <SampleRate>

Sets the final user sample rate for the acquired I/Q data. Thus, the user sample rate can be modified without affecting the actual data capturing settings on the R&S FSWP.

Note: The smaller the user sample rate, the smaller the usable I/Q bandwidth, see [Section 4.1.1, "Sample rate and maximum usable I/Q bandwidth for RF input"](#), on page 25.

Parameters:

<SampleRate> The valid sample rates are described in [Section 4.1.1, "Sample rate and maximum usable I/Q bandwidth for RF input"](#), on page 25.

*RST: 32 MHz

Default unit: HZ

Manual operation: See ["Sample Rate"](#) on page 65

TRACe:IQ:TPISample?

Queries the time offset from the sample start to the trigger event (trigger point in sample = TPIS). Since the R&S FSWP usually samples with a much higher sample rate than the specific application actually requires, the trigger point determined internally is much more precise than the one determined from the (downsampled) data in the application. Thus, the TPIS indicates the offset from the sample start to the actual trigger event.

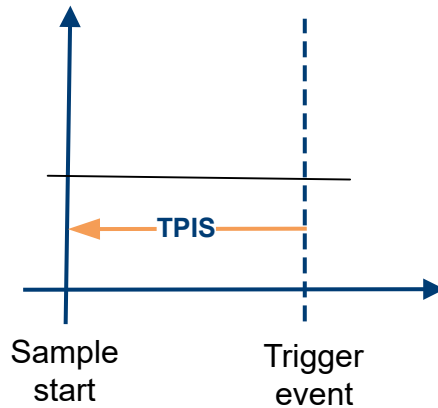

This value can only be determined in triggered measurements using external or IFPower triggers, otherwise the value is 0.

Return values:

<TPIS> numeric value
 Default unit: s

Example:

TRAC:IQ:TPIS?

Result for a sample rate of 1 MHz: between 0 and 1/1 MHz, i.e. between 0 and 1 μ s (the duration of 1 sample).

Usage:

Query only

TRACe:IQ:WBAND:MBWidth <Limit>

Defines the maximum analysis bandwidth. Any value can be specified; the next higher fixed bandwidth is used.

Parameters:

<Limit>

80 MHz

Restricts the analysis bandwidth to a maximum of 80 MHz. The bandwidth extension option R&S FSWP-B320 is deactivated.

TRACe:IQ:WBAND[:STATe] is set to OFF.

160 MHz

Restricts the analysis bandwidth to a maximum of 160 MHz. The bandwidth extension option R&S FSWP-B320 is deactivated.

TRACe:IQ:WBAND[:STATe] is set to ON.

160 MHz | MAX

The bandwidth extension option is activated. The currently available maximum bandwidth is allowed.

`TRACe:IQ:WBANd[:STATe]` is set to ON.

*RST: maximum available

Default unit: Hz

Example:

```
TRAC:IQ:WBAN:MBW 82 MHZ
TRAC:IQ:WBAN:MBW?
160000000
```

Manual operation: See "[Maximum Bandwidth](#)" on page 66

TRACe:IQ:WBANd[:STATe] <State>

Determines whether the wideband provided by bandwidth extension options is used or not (if installed).

Parameters:

<State> ON | OFF | 0 | 1
OFF | 0
 Switches the function off
ON | 1
 Switches the function on

Manual operation: See "[Maximum Bandwidth](#)" on page 66

TRACe:IQ:WFILter <State>

Activates a 200 MHz filter before the A/D converter, thus restricting the processed bandwidth to 200 MHz while using the wideband processing path in the R&S FSWP. For prerequisites see manual operation.

Parameters:

<State> ON | OFF | 0 | 1
OFF | 0
 Switches the function off
ON | 1
 Switches the function on
 *RST: 0

Manual operation: See "[200 MHz Filter](#)" on page 66

8.6.12 Automatic configuration

<code>[SENSe:]ADJust:ALL</code>	146
<code>[SENSe:]ADJust:CONFigure:LEVel:DURation</code>	146
<code>[SENSe:]ADJust:CONFigure:LEVel:DURation:MODE</code>	146
<code>[SENSe:]ADJust:CONFigure:HYSTeresis:LOWer</code>	147

[SENSe:]ADJust:CONFigure:HYSteresis:UPPer.....	147
[SENSe:]ADJust:CONFigure:TRIGger.....	147
[SENSe:]ADJust:FREQuency.....	148
[SENSe:]ADJust:LEVel.....	148

[SENSe:]ADJust:ALL

Initiates a measurement to determine and set the ideal settings for the current task automatically (only once for the current measurement).

This includes:

- Reference level

Example: ADJ:ALL

Manual operation: See "[Adjusting all Determinable Settings Automatically \(Auto All\)](#)" on page 73

[SENSe:]ADJust:CONFigure:LEVel:DURation <Duration>

To determine the ideal reference level, the R&S FSWP performs a measurement on the current input data. This command defines the length of the measurement if [SENSe:]ADJust:CONFigure:LEVel:DURation:MODE is set to MANual.

Parameters:

<Duration> Numeric value in seconds
 Range: 0.001 to 16000.0
 *RST: 0.001
 Default unit: s

Example: ADJ:CONF:DUR:MODE MAN
 Selects manual definition of the measurement length.
 ADJ:CONF:LEV:DUR 5ms
 Length of the measurement is 5 ms.

Manual operation: See "[\(Meas Time Manual\)](#)" on page 74

[SENSe:]ADJust:CONFigure:LEVel:DURation:MODE <Mode>

To determine the ideal reference level, the R&S FSWP performs a measurement on the current input data. This command selects the way the R&S FSWP determines the length of the measurement .

Parameters:

<Mode> **AUTO**
 The R&S FSWP determines the measurement length automatically according to the current input data.

MANual
 The R&S FSWP uses the measurement length defined by [SENSe:]ADJust:CONFigure:LEVel:DURation on page 146.

*RST: AUTO

Manual operation: See "[Resetting the Automatic Measurement Time \(Meas Time Auto\)](#)" on page 74
See "[\(Meas Time Manual\)](#)" on page 74

[SENSe:]ADJJust:CONFigure:HYSTeresis:LOWer <Threshold>

When the reference level is adjusted automatically using the [SENSe:]ADJJust:LEVEl on page 148 command, the internal attenuators and the preamplifier are also adjusted. To avoid frequent adaptation due to small changes in the input signal, you can define a hysteresis. This setting defines a lower threshold the signal must fall below (compared to the last measurement) before the reference level is adapted automatically.

Parameters:

<Threshold> Range: 0 dB to 200 dB
 *RST: +1 dB
 Default unit: dB

Example:

SENS:ADJ:CONF:HYST:LOW 2

For an input signal level of currently 20 dBm, the reference level is only adjusted when the signal level falls below 18 dBm.

Manual operation: See "[Lower Level Hysteresis](#)" on page 75

[SENSe:]ADJJust:CONFigure:HYSTeresis:UPPer <Threshold>

When the reference level is adjusted automatically using the [SENSe:]ADJJust:LEVEl on page 148 command, the internal attenuators and the preamplifier are also adjusted. To avoid frequent adaptation due to small changes in the input signal, you can define a hysteresis. This setting defines an upper threshold the signal must exceed (compared to the last measurement) before the reference level is adapted automatically.

Parameters:

<Threshold> Range: 0 dB to 200 dB
 *RST: +1 dB
 Default unit: dB

Example:

SENS:ADJ:CONF:HYST:UPP 2

Example:

For an input signal level of currently 20 dBm, the reference level is only adjusted when the signal level rises above 22 dBm.

Manual operation: See "[Upper Level Hysteresis](#)" on page 74

[SENSe:]ADJJust:CONFigure:TRIGger <State>

Defines the behavior of a triggered measurement when adjusting a setting automatically (using SENS:ADJ:LEV ON, for example).

See ["Adjusting settings automatically during triggered measurements"](#) on page 73.

Parameters:

<State> ON | OFF | 0 | 1
ON | 1
 (default:) The measurement for adjustment waits for the next trigger.
OFF | 0
 The measurement for adjustment is performed without waiting for a trigger (corresponds to "Continue" in manual operation).
 *RST: 0

Example:

```
//Use default ref level at 0.00 dBm.
//Define an RF power trigger at -20 dBm
:TRIG:SEQ:SOUR RFP
:TRIG:SEQ:LEV:RFP -20
//Perform adjustment measurement without waiting for trigger
SENS:ADJ:CONF:TRIG OFF
//Perform auto level adjustment
:SENS:ADJ:LEV;*WAI
```

[SENSe:]ADJust:FREQuency

Sets the center frequency to the frequency with the highest signal level in the current frequency range.

Example: ADJ:FREQ

Manual operation: See ["Adjusting the Center Frequency Automatically \(Auto Frequency\)"](#) on page 73

[SENSe:]ADJust:LEVel

Initiates a single (internal) measurement that evaluates and sets the ideal reference level for the current input data and measurement settings. Thus, the settings of the RF attenuation and the reference level are optimized for the signal level. The R&S FSWP is not overloaded and the dynamic range is not limited by an S/N ratio that is too small.

Example: ADJ:LEV

Manual operation: See ["Setting the Reference Level Automatically \(Auto Level\)"](#) on page 55

8.6.13 Configuring the result display

DISPlay:FORMat.....	149
DISPlay[:WINDow<n>]:SIZE.....	149
LAYout:ADD[:WINDow]?.....	149
LAYout:CATalog[:WINDow]?.....	151
LAYout:IDENtify[:WINDow]?.....	151

LAYout:REMove[:WINDow]	151
LAYout:REPLace[:WINDow]	152
LAYout:SPLitter	152
LAYout:WINDow<n>:ADD?	154
LAYout:WINDow<n>:IDENTify?	154
LAYout:WINDow<n>:REMove	155
LAYout:WINDow<n>:REPLace	155

DISPlay:FORMat <Format>

Determines which tab is displayed.

Parameters:

<Format>

SPLit

Displays the MultiView tab with an overview of all active channels

SINGle

Displays the measurement channel that was previously focused.

*RST: SING

Example:

DISP:FORM SPL

DISPlay[:WINDow<n>]:SIZE <Size>

Maximizes the size of the selected result display window *temporarily*. To change the size of several windows on the screen permanently, use the [LAY:SPL](#) command (see [LAYout:SPLitter](#) on page 152).

Suffix:

<n>

Window

Parameters:

<Size>

LARGE

Maximizes the selected window to full screen. Other windows are still active in the background.

SMALI

Reduces the size of the selected window to its original size. If more than one measurement window was displayed originally, these are visible again.

*RST: SMALI

Example:

DISP:WIND2:SIZE LARG

LAYout:ADD[:WINDow]? <WindowName>, <Direction>, <WindowType>

Adds a window to the display in the active channel.

Is always used as a query so that you immediately obtain the name of the new window as a result.

To replace an existing window, use the [LAYout:REPLace\[:WINDow\]](#) command.

Query parameters:

<WindowName>	String containing the name of the existing window the new window is inserted next to. By default, the name of a window is the same as its index. To determine the name and index of all active windows, use the LAYout:CATalog[:WINDow]? query .
<Direction>	LEFT RIGHT ABOVE BELOW Direction the new window is added relative to the existing window.
<WindowType>	text value Type of result display (evaluation method) you want to add. See the table below for available parameter values.

Return values:

<NewWindowName>	When adding a new window, the command returns its name (by default the same as its number) as a result.
-----------------	---

Example:

```
LAY:ADD? '1', LEFT, MTAB
```

Result:

```
'2'
```

Adds a new window named '2' with a marker table to the left of window 1.

Usage:

Query only

Manual operation:

See ["Magnitude"](#) on page 18
 See ["Spectrum"](#) on page 19
 See ["I/Q-Vector"](#) on page 19
 See ["Real/Imag \(I/Q\)"](#) on page 20
 See ["Phase vs. Time"](#) on page 21
 See ["Marker Table"](#) on page 21
 See ["Marker Peak List"](#) on page 22

Table 8-4: <WindowType> parameter values for IQ Analyzer application

Parameter value	Window type
FREQ	"Spectrum"
MAGN	"Magnitude"
MTABle	"Marker table"
PEAKlist	"Marker peak list"
PHASe	"Phase vs. time"
RIMAG	"Real/Imag (I/Q)"
VECT	"I/Q Vector"

LAYout:CATalog[:WINDow]?

Queries the name and index of all active windows in the active channel from top left to bottom right. The result is a comma-separated list of values for each window, with the syntax:

<WindowName_1>,<WindowIndex_1>..<WindowName_n>,<WindowIndex_n>

Return values:

<WindowName> string
Name of the window.
In the default state, the name of the window is its index.

<WindowIndex> **numeric value**
Index of the window.

Example: LAY:CAT?
Result:
'2',2,'1',1
Two windows are displayed, named '2' (at the top or left), and '1' (at the bottom or right).

Usage: Query only

LAYout:IDENtify[:WINDow]? <WindowName>

Queries the **index** of a particular display window in the active channel.

Query parameters:

<WindowName> String containing the name of a window.

Return values:

<WindowIndex> Index number of the window.

Example: LAY:IDEN:WIND? '2'
Queries the index of the result display named '2'.
Response:
2

Usage: Query only

LAYout:REMOve[:WINDow] <WindowName>

Removes a window from the display in the active channel.

Setting parameters:

<WindowName> String containing the name of the window. In the default state, the name of the window is its index.

Example: LAY:REM '2'
Removes the result display in the window named '2'.

Usage: Setting only

LAYout:REPLace[:WINDow] <WindowName>, <WindowType>

Replaces the window type (for example from "Diagram" to "Result Summary") of an already existing window in the active channel while keeping its position, index and window name.

To add a new window, use the `LAYout:ADD[:WINDow]?` command.

Setting parameters:

<WindowName> String containing the name of the existing window.
By default, the name of a window is the same as its index. To determine the name and index of all active windows in the active channel, use the `LAYout:CATalog[:WINDow]?` query.

<WindowType> Type of result display you want to use in the existing window.
See `LAYout:ADD[:WINDow]?` on page 149 for a list of available window types.

Example: `LAY:REPL:WIND '1',MTAB`
Replaces the result display in window 1 with a marker table.

Usage: Setting only

LAYout:SPLitter <Index1>, <Index2>, <Position>

Changes the position of a splitter and thus controls the size of the windows on each side of the splitter.

Compared to the `DISPlay[:WINDow<n>]:SIZE` on page 149 command, the `LAYout:SPLitter` changes the size of all windows to either side of the splitter permanently, it does not just maximize a single window temporarily.

Note that windows must have a certain minimum size. If the position you define conflicts with the minimum size of any of the affected windows, the command does not work, but does not return an error.

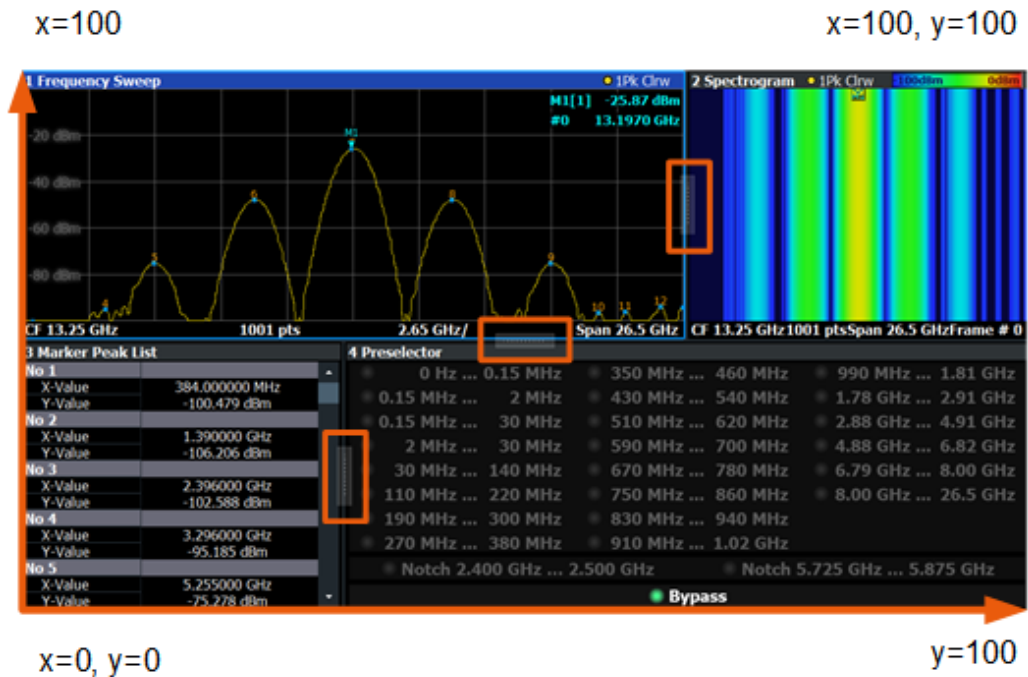

Figure 8-1: SmartGrid coordinates for remote control of the splitters

Setting parameters:

- <Index1> The index of one window the splitter controls.
- <Index2> The index of a window on the other side of the splitter.
- <Position> New vertical or horizontal position of the splitter as a fraction of the screen area (without channel and status bar and softkey menu).
The point of origin (x = 0, y = 0) is in the lower left corner of the screen. The end point (x = 100, y = 100) is in the upper right corner of the screen. (See Figure 8-1.)
The direction in which the splitter is moved depends on the screen layout. If the windows are positioned horizontally, the splitter also moves horizontally. If the windows are positioned vertically, the splitter also moves vertically.

Range: 0 to 100

Example:

LAY:SPL 1,3,50

Moves the splitter between window 1 ("Frequency Sweep") and 3 ("Marker Table") to the center (50%) of the screen, i.e. in the figure above, to the left.

Example: `LAY:SPL 1,4,70`
 Moves the splitter between window 1 ('Frequency Sweep') and 3 ('Marker Peak List') towards the top (70%) of the screen. The following commands have the exact same effect, as any combination of windows above and below the splitter moves the splitter vertically.

`LAY:SPL 3,2,70`
`LAY:SPL 4,1,70`
`LAY:SPL 2,1,70`

Usage: Setting only

LAYout:WINDow<n>:ADD? <Direction>,<WindowType>

Adds a measurement window to the display. Note that with this command, the suffix <n> determines the existing window next to which the new window is added. Unlike [LAYout:ADD\[:WINDow\]?](#), for which the existing window is defined by a parameter.

To replace an existing window, use the [LAYout:WINDow<n>:REPLace](#) command.

Is always used as a query so that you immediately obtain the name of the new window as a result.

Suffix:

<n> [Window](#)

Query parameters:

<Direction> LEFT | RIGHT | ABOVE | BELOW

<WindowType> Type of measurement window you want to add.
 See [LAYout:ADD\[:WINDow\]?](#) on page 149 for a list of available window types.

Return values:

<NewWindowName> When adding a new window, the command returns its name (by default the same as its number) as a result.

Example: `LAY:WIND1:ADD? LEFT,MTAB`
Result:
`'2'`
 Adds a new window named '2' with a marker table to the left of window 1.

Usage: Query only

LAYout:WINDow<n>:IDENTify?

Queries the **name** of a particular display window (indicated by the <n> suffix) in the active channel.

Note: to query the **index** of a particular window, use the [LAYout:IDENTify\[:WINDow\]?](#) command.

Suffix:	
<n>	Window
Return values:	
<WindowName>	String containing the name of a window. In the default state, the name of the window is its index.
Example:	LAY:WIND2:IDEN? Queries the name of the result display in window 2. Response: '2'
Usage:	Query only

LAYout:WINDow<n>:REMOve

Removes the window specified by the suffix <n> from the display in the active channel.

The result of this command is identical to the [LAYout:REMOve\[:WINDow\]](#) command.

Suffix:	
<n>	Window
Example:	LAY:WIND2:REM Removes the result display in window 2.
Usage:	Event

LAYout:WINDow<n>:REPLace <WindowType>

Changes the window type of an existing window (specified by the suffix <n>) in the active channel.

The effect of this command is identical to the [LAYout:REPLace\[:WINDow\]](#) command.

To add a new window, use the [LAYout:WINDow<n>:ADD?](#) command.

Suffix:	
<n>	Window
Setting parameters:	
<WindowType>	Type of measurement window you want to replace another one with. See LAYout:ADD[:WINDow]? on page 149 for a list of available window types.
Example:	LAY:WIND2:REPL MTAB Replaces the result display in window 2 with a marker table.
Usage:	Setting only

8.7 Analyzing results

For a comprehensive description of the commands required to analyze results (trace and marker functionality), please refer to the R&S FSWP User Manual.

CALCulate<n>:MARKer<m>:SEARch.....	156
CALCulate<n>:SGRam:LAYout.....	156
CALCulate<n>:SPECTrogram:LAYout.....	156
CALCulate<n>:SPECTrogram:TRACe.....	157
CALCulate<n>:SGRam:TRACe.....	157

CALCulate<n>:MARKer<m>:SEARch <MarkReallmag>

Selects the trace type a marker search is performed on.

Suffix:

<n> irrelevant

<m> irrelevant

Parameters:

<MarkReallmag>

REAL

Marker search functions are performed on the real trace of the "I/Q" measurement.

IMAG

Marker search functions are performed on the imaginary trace of the "I/Q" measurement.

MAGN

Marker search functions are performed on the magnitude of the I and Q data.

*RST: REAL

Example:

CALC4:MARK:SEAR IMAG

Manual operation: See "[Branch for Peaksearch](#)" on page 77

CALCulate<n>:SGRam:LAYout <State>

CALCulate<n>:SPECTrogram:LAYout <State>

This command selects the state and size of spectrograms.

The command is available for result displays that support spectrograms.

Suffix:

<n> [Window](#)

Parameters:

<State>

FULL

Only the spectrogram is displayed, the trace diagram is not.

SPLIT

Spectrogram and trace diagram share a window.

OFF

Only the trace diagram is displayed, the spectrogram is not.

*RST: OFF

Example:

CALC4:SPEC:LAY FULL

Shows the spectrogram in window 4. The corresponding trace diagram is hidden.

Manual operation: See ["State"](#) on page 76

CALCulate<n>:SPECtrogram:TRACe <Trace>

CALCulate<n>:SGRam:TRACe <Trace>

Suffix:

<n> [Window](#)

Parameters:

<Trace> TRACe1 | TRACe2 | TRACe3 | TRACe4 | TRACe5 | TRACe6

Manual operation: See ["Trace"](#) on page 77

8.8 Importing and exporting I/Q data

Alternatively to capturing I/Q data by the I/Q Analyzer itself, stored I/Q data from previous measurements or other applications can be imported to the I/Q Analyzer. Furthermore, I/Q data processed in the I/Q Analyzer can be stored to a file for further evaluation in other applications.

For details on importing and exporting I/Q data see [Section 4.4, "I/Q data import and export"](#), on page 31.

MMEMory:LOAD:IQ:STATe	157
MMEMory:STORe<n>:IQ:COMMeNt	158
MMEMory:STORe<n>:IQ:STATe	158

MMEMory:LOAD:IQ:STATe 1, <FileName>

Restores I/Q data from a file.

Setting parameters:

<FileName> string
 String containing the path and name of the source file.
 The file type is determined by the file extension. If no file extension is provided, the file type is assumed to be `.iq.tar`.
 For `.mat` files, Matlab® v4 is assumed.

Example:

```
MMEM:LOAD:IQ:STAT 1, 'C:\R_S\Instr\user\data.iq.tar'
```

Loads IQ data from the specified file.

Usage:

Setting only

Manual operation: See "[I/Q Import](#)" on page 43

MMEMory:STORe<n>:IQ:COMMeNt <Comment>

Adds a comment to a file that contains I/Q data.

Suffix:

<n> irrelevant

Parameters:

<Comment> String containing the comment.

Example:

```
MMEM:STOR:IQ:COMM 'Device test 1b'
Creates a description for the export file.
MMEM:STOR:IQ:STAT 1, 'C:
\R_S\Instr\user\data.iq.tar'
Stores I/Q data and the comment to the specified file.
```

Manual operation: See "[I/Q Export](#)" on page 45

MMEMory:STORe<n>:IQ:STATe <1>, <FileName>

Writes the captured I/Q data to a file.

By default, the contents of the file are in 32-bit floating point format.

Suffix:

<n> 1..n

Parameters:

<1>

<FileName>

String containing the path and name of the target file.
The file type is determined by the file extension. If no file extension is provided, the file type is assumed to be .iq.tar.
For .mat files, Matlab® v4 is assumed.

Example:

```
MMEM:STOR:IQ:STAT 1, 'C:
\R_S\Instr\user\data.iq.tar'
Stores the captured I/Q data to the specified file.
```

Usage:

Asynchronous command

Manual operation: See "[I/Q Export](#)" on page 45

8.9 Querying the status registers

The R&S FSWP-I/Q Analyzer uses the standard status registers of the R&S FSWP.

For details on the common R&S FSWP status registers refer to the description of remote control basics in the R&S FSWP user manual.



*RST does not influence the status registers.

8.10 Programming examples

The following programming examples demonstrate how to capture I/Q data and perform I/Q data analysis using the I/Q Analyzer in a remote environment.

- [I/Q analysis with graphical evaluation](#)..... 159
- [Basic I/Q analysis with improved performance](#)..... 160

8.10.1 I/Q analysis with graphical evaluation

This example demonstrates how to configure and perform a basic I/Q data acquisition and analyze the data using the I/Q Analyzer in a remote environment.

```
//-----Activating the I/Q Analyzer application -----
*RST
//Reset the instrument
INST:CRE IQ,'IQANALYZER'
//Creates a new measurement channel named 'IQANALYZER'.
INIT:CONT OFF
//Switches to single sweep mode

//-----Configuring Data Acquisition-----
TRAC:IQ:SRAT 32MHZ
//Defines the sample rate.
TRAC:IQ:RLEN 1000
//Sets the record length (number of samples to capture) to 1000 samples.
TRAC:IQ:BWID?
//Queries the bandwidth of the resampling filter, determined by the sample rate
FORM:DATA REAL,32
//Formats the data as 32-byte real values.
TRAC:IQ:DATA:FORM IQBL
//Lists all I values first, then all Q values in the trace results.

//-----Configuring the Trace-----
TRAC:IQ:AVER ON
//Defines averaging for the I/Q trace.
TRAC:IQ:AVER:COUN 10
//Defines an average over 10 sweeps.

DISP:TRAC1:MODE WRIT
DISP:TRAC2:MODE MAXH
DISP:TRAC3:MODE MINH
//Changes the trace modes.
```

```

//-----Performing the Measurement-----
INIT;*WAI
//Initiates a new measurement and waits until the sweep has finished.

//-----Retrieving Results-----

TRAC:DATA? TRACE1
TRAC:DATA? TRACE2
TRAC:DATA? TRACE3
//Returns the magnitude for each sweep point

LAY:REPL:WIND '1',RIMAG
//Changes the result display to Real/Imag (I/Q)

CALC:MARK:SEAR MAGN
//Configures searches to search both I and Q branches.
CALC:MARK:Y?
//Queries the result of the peak search on both branches.

TRAC:IQ:DATA:MEM? 0,500
//Returns the first 500 samples of the stored I/Q data for the measurement.
//For each sample, first the I-value, then the Q-value is listed.

TRAC:IQ:DATA:MEM? 500,500
//Returns the second half of the 1000 captured sample values.

```

8.10.2 Basic I/Q analysis with improved performance

This example demonstrates how to configure and perform a basic I/Q data acquisition and analyze the data using the I/Q Analyzer functionality in a remote environment.

```

//-----Activating the I/Q Analyzer application -----
*RST
//Reset the instrument

INIT:CONT OFF
//Switches to single sweep mode
TRACE:IQ ON
//Switches the (internal) operating mode of the current measurement channel to
//simple I/Q data acquisition mode while retaining the relevant parameters
//from the Spectrum mode.

//-----Configuring Data Acquisition-----
TRACE:IQ:SET NORM,0,32000000,IQP,POS,0,1000
//Configures the sample rate as 32 MHz, IQP trigger, positive trigger slope,
//no pretrigger samples, 1000 samples to capture
FORM REAL,32
//The data is formatted as real values.

```

```
//-----Configuring I/Q Gating-----
TRAC:IQ:EGAT ON
//Turns on gated measurement.
TRAC:IQ:EGAT:TYPE LEV
//Select the level gate type.
TRAC:IQ:EGAT:LENG 20
//Sets the gate length to 20 samples.
TRAC:IQ:EGAT:GAP 20
//Sets the interval between gate periods to 20 samples.
TRAC:IQ:EGAT:NOF 2
//Sets the number of gate periods after the trigger signal to 2.
TRIG:SOUR IQP
//Defines the magnitude of the sampled I/Q data to be used as a trigger.
TRIG:LEV:IQP -30dbm
//Sets the trigger level.

//-----Performing the Measurement and Retrieving Results-----
TRAC:IQ:DATA?; *WAI;
//Performs a measurement and returns the RF input voltage at each sample point
//(first 1000 I-values, then 1000 Q-values).

TRAC:IQ:DATA:MEM? 0,500
//Returns the first 500 samples of the stored trace data for the measurement.
//For each sample, first the I-value, then the Q-value is listed.

TRAC:IQ:DATA:MEM? 500,500
//Returns the second half of the 1000 captured sample values.
```

Annex

A Annex: reference

A.1	Formats for returned values: ASCII format and binary format.....	163
A.2	Reference: format description for I/Q data files.....	163
A.3	Reference: supported I/Q file formats.....	165
A.3.1	I/Q data file format (iq-tar).....	166
A.3.1.1	I/Q parameter XML file specification.....	167
	Minimum data elements.....	168
	Example.....	169
A.3.1.2	I/Q data binary file.....	171
A.3.2	CSV file format.....	174
A.3.2.1	Mandatory data elements.....	174
A.3.2.2	Optional data elements.....	174
A.3.2.3	Example.....	175
A.3.2.4	Simple CSV format.....	176
A.3.3	IQW file format.....	176
A.3.4	Matlab® v. 4 / v. 7.3 file format.....	177
A.3.4.1	Mandatory data elements.....	177
A.3.4.2	Optional data elements.....	178
A.3.4.3	Example.....	179
A.3.4.4	Simple matlab® format.....	179
A.3.5	AID format.....	180
A.3.5.1	Data body.....	182
A.3.6	WV format.....	189
A.3.6.1	Mandatory elements.....	189
A.3.6.2	Optional elements.....	190

A.1 Formats for returned values: ASCII format and binary format

When trace data is retrieved using the `TRAC:DATA` or `TRAC:IQ:DATA` command, the data is returned in the format defined using the `FORMat[:DATA]` on page 106. The possible formats are described here.

- **ASCII Format (FORMat ASCII):**
The data is stored as a list of comma-separated values (CSV) of the measured values in floating point format.
- **Binary Format (FORMat REAL,16/32/64):**
The data is stored as binary data (definite length block data according to IEEE 488.2), each measurement value being formatted in 16-bit/32-bit/64-bit IEEE 754 floating-point-format.
The schema of the result string is as follows:
#<Length of length><Length of data><value1><value2>...<value n>
with:

<Length of length>	Number of digits of the following number of data bytes
<Length of data>	Number of following data bytes
<Value>	2-byte/4-byte/8-byte floating point value

Example: #41024<Data>... contains 1024 data bytes

Data blocks larger than 999,999,999 bytes

According to SCPI, the header of the block data format allows for a maximum of 9 characters to describe the data length. Thus, the maximum REAL 32 data that can be represented is 999,999,999 bytes. However, the R&S FSWP is able to send larger data blocks. In this case, the length of the data block is placed in brackets, e.g.
#(1234567890) <value1><value2>...



Reading out data in binary format is quicker than in ASCII format. Thus, binary format is recommended for large amounts of data.

A.2 Reference: format description for I/Q data files

This section describes how I/Q data is transferred to the memory during remote control (see `TRACe:IQ:DATA:FORMat` command).

For details on the format of the individual values, see [Section A.1, "Formats for returned values: ASCII format and binary format"](#), on page 163.

For details on the format of I/Q export files (using the "I/Q Export" function), see the R&S FSWP User Manual.

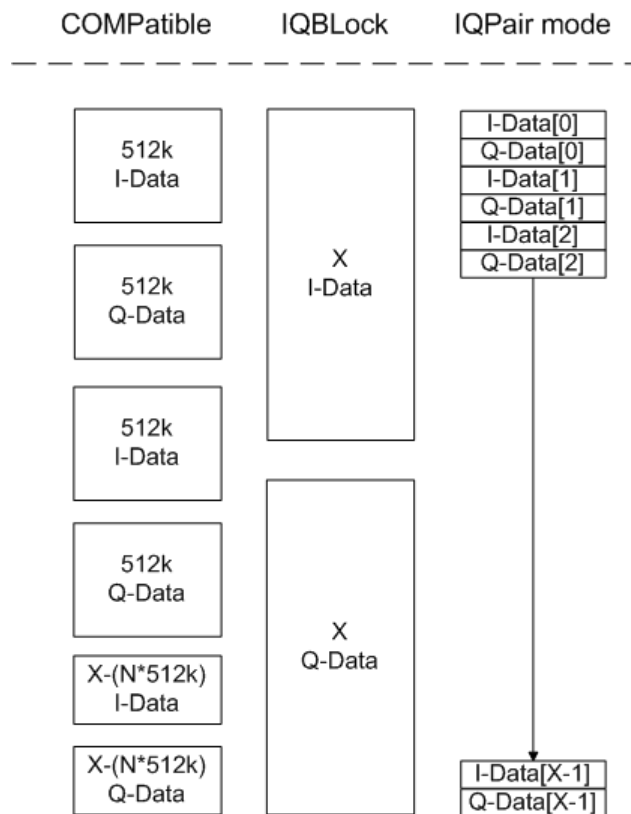

Figure A-1: I/Q data formats

Note: 512k corresponds to 524288 samples

For maximum performance, the formats "Compatible" or "IQPair" should be used. Furthermore, for large amounts of data, the data should be in binary format to improve performance.

In binary format, the number of I- and Q-data can be calculated as follows:

$$\# \text{ of I-Data} = \# \text{ of Q-Data} = \frac{\# \text{ of DataBytes}}{8}$$

For the format "QBLock", the offset of Q-data in the output buffer can be calculated as follows:

$$Q\text{-Data-Offset} = \frac{(\# \text{ of DataBytes})}{2} + \text{LengthIndicatorDigits}$$

with "LengthIndicatorDigits" being the number of digits of the length indicator including the #. In the example above (#41024...), this results in a value of 6 for "LengthIndicatorDigits" and the offset for the Q-data results in $512 + 6 = 518$.

A.3 Reference: supported I/Q file formats

Various file types are supported for I/Q data import and export. The most important characteristics for each format are described here.



For best performance and to ensure comprehensive meta data is available, use the `iq.tar` format. This is a widely used file format for Rohde & Schwarz products.

Table A-1: Characteristics of data file formats

File format	File extension	Comment
IQ.tar	<code>.iq.tar</code>	An <code>IQ.tar</code> file contains I/Q data in binary format together with meta information that describes the nature and the source of data, e.g. the sample rate. The objective of the <code>IQ.tar</code> file format is to separate I/Q data from the meta information while still having both inside one file. In addition, the file format allows a preview of the I/Q data in a web browser, and inclusion of user-specific data. Several streams of data can be provided in one file.
IQW	<code>.iqw</code>	A binary file format containing one channel of complex IQ data. The file contains float32 data in a binary format (interleaved IQIQ or in blocks, IIIQQQ). The file does not contain any additional information as a header. This format requires setting the sample rate and measurement time or record length manually.
CSV	<code>.csv</code>	A file containing I/Q data as comma-separated values (CSV). Additional metadata can be included.
Simple CSV	<code>.csv</code>	(Import only) Simple CSV contains I/Q data only, without any header or meta data. That is, the file contains only (I,Q) data pairs, separated by commas. Several streams of data can be provided in one file. This format requires setting the sample rate and measurement time or record length manually.
Matlab® v4	<code>.mat</code>	A file containing I/Q data in Matlab® file format v4. Channel-related information is stored in matlab variables with names starting with 'ChX_'. 'X' represents the number of the channel with a lower bound of 1, e.g. the variable <code>Ch1_ChannelName</code> contains the name of the first channel. The corresponding data is contained in <code>ChX_Data</code> . Optional user data can be saved to variables named <code>UserDataX</code> , where 'X' starts at 0. The variable <code>UserData_Count</code> contains the number of <code>UserData</code> variables. For compatibility reasons user data needs to be saved as a 2xN char array, where the first row contains the key of the user data and the second row the actual value. Both rows must have the same column count and are therefore right-padded with white spaces. Variables can be written to the <code>*.mat</code> files in arbitrary order. Limitations: In general, the file format is limited to a maximum of 2 GB. A maximum of 100000000 values can be stored in a single variable, e.g. 50000000 complex data samples.
Matlab® v7.3	<code>.mat</code>	A file containing I/Q data in Matlab® file format v7.3.
Simple Matlab®	<code>.mat</code>	(Import only) Simple Matlab® format contains I/Q data only, without any meta data. That is, the file contains only variables (double, double) for the corresponding channel data. This format requires setting the sample rate and measurement time or record length manually.

File format	File extension	Comment
AMMOS intermediate frequency data format	.aid	Format used to transmit real or complex baseband signals. The IF signal is sent along with information that characterizes the datastream and datastream source. All datastreams have a frame-based structure, consisting of a global frame header coupled with a data-type specific frame body (i.e. the frame payload).
wv	.wv	(Import only) Proprietary file format used by Rohde & Schwarz signal generators to store waveform data. A waveform file contains a header and raw I/Q samples.

- [I/Q data file format \(iq-tar\)](#)..... 166
- [CSV file format](#)..... 174
- [IQW file format](#)..... 176
- [Matlab® v. 4 / v. 7.3 file format](#)..... 177
- [AID format](#)..... 180
- [WV format](#)..... 189

A.3.1 I/Q data file format (iq-tar)

I/Q data is packed in a file with the extension `.iq.tar`. An `iq-tar` file contains I/Q data in binary format together with meta information that describes the nature and the source of data, e.g. the sample rate. The objective of the `iq-tar` file format is to separate I/Q data from the meta information while still having both inside one file. In addition, the file format allows you to include user-specific data and to preview the I/Q data in a web browser (not supported by all web browsers).

The `iq-tar` container packs several files into a single `.tar` archive file. Files in `.tar` format can be unpacked using standard archive tools (see http://en.wikipedia.org/wiki/Comparison_of_file_archivers) available for most operating systems. The advantage of `.tar` files is that the archived files inside the `.tar` file are not changed (not compressed) and thus it is possible to read the I/Q data directly within the archive without the need to unpack (untar) the `.tar` file first.



Sample iq-tar files

Some sample `iq-tar` files are provided in the `C:\R_S\INSTR\USER\Demo\` directory on the R&S FSWP.



An application note on converting Rohde & Schwarz I/Q data files is available from the Rohde & Schwarz website:

[1EF85: Converting R&S I/Q data files](#)

Contained files

An `iq-tar` file must contain the following files:

- **I/Q parameter XML file**, e.g. `xyz.xml`

Contains meta information about the I/Q data (e.g. sample rate). The filename can be defined freely, but there must be only one single I/Q parameter XML file inside an `iq-tar` file.

- **I/Q data binary file**, e.g. `xyz.complex.float32`
Contains the binary I/Q data of all channels. There must be only one single I/Q data binary file inside an `iq-tar` file.

Optionally, an `iq-tar` file can contain the following file:

- **I/Q preview XSLT file**, e.g. `open_IqTar_xml_file_in_web_browser.xslt`
Contains a stylesheet to display the I/Q parameter XML file and a preview of the I/Q data in a web browser (not supported by all web browsers).

A sample stylesheet is available at http://www.rohde-schwarz.com/file/open_IqTar_xml_file_in_web_browser.xslt.

- [I/Q parameter XML file specification](#)..... 167
- [I/Q data binary file](#)..... 171

A.3.1.1 I/Q parameter XML file specification



The content of the I/Q parameter XML file must comply with the XML schema `RsIqTar.xsd` available at: <http://www.rohde-schwarz.com/file/RsIqTar.xsd>.

In particular, the order of the XML elements must be respected, i.e. `iq-tar` uses an "ordered XML schema". For your own implementation of the `iq-tar` file format make sure to validate your XML file against the given schema.

The following example shows an I/Q parameter XML file. The XML elements and attributes are explained in the following sections.

Sample I/Q parameter XML file: `xyz.xml`

```
<?xml version="1.0" encoding="UTF-8"?>
<?xml-stylesheet type="text/xsl"
href="open_IqTar_xml_file_in_web_browser.xslt"?>
<RS_IQ_TAR_FileFormat fileFormatVersion="1"
xsi:noNamespaceSchemaLocation="RsIqTar.xsd"
xmlns:xsi="http://www.w3.org/2001/XMLSchema-instance">
  <Name>R&S FSWP</Name>
  <Comment>Here is a comment</Comment>
  <DateTime>2011-01-24T14:02:49</DateTime>
  <Samples>68751</Samples>
  <Clock unit="Hz">6.5e+006</Clock>
  <Format>complex</Format>
  <DataType>float32</DataType>
  <ScalingFactor unit="V">1</ScalingFactor>
  <NumberOfChannels>1</NumberOfChannels>
  <DataFilename>xyz.complex.float32</DataFilename>
  <UserData>
    <UserDefinedElement>Example</UserDefinedElement>
  </UserData>
```

```
<PreviewData>...</PreviewData>
</RS_IQ_TAR_FileFormat>
```

Minimum data elements

The following data elements are the minimum required for a valid `iq-tar` file. They are always provided by an `iq-tar` file export from a Rohde & Schwarz product. If not specified otherwise, it must be available in all `iq-tar` files used to import data to a Rohde & Schwarz product.

Element	Possible Values	Description
<RS_IQ_TAR_FileFormat>	-	The root element of the XML file. It must contain the attribute <code>fileFormatVersion</code> that contains the number of the file format definition.
<Name>	string	Optional: describes the device or application that created the file.
<Comment>	string	Optional: contains text that further describes the contents of the file.
<DateTime>	yyyy-mm-ddThh:mm:ss	Contains the date and time of the creation of the file. Its type is <code>xs:dateTime</code> (see <code>RsIqTar.xsd</code>).
<Samples>	integer	Contains the number of samples of the I/Q data. For multi-channel signals all channels have the same number of samples. One sample can be: <ul style="list-style-type: none"> • A complex number represented as a pair of I and Q values • A complex number represented as a pair of magnitude and phase values • A real number represented as a single real value See also <Format> element.
<Clock>	double	Contains the clock frequency in Hz, i.e. the sample rate of the I/Q data. A signal generator typically outputs the I/Q data at a rate that equals the clock frequency. If the I/Q data was captured with a signal analyzer, the signal analyzer used the clock frequency as the sample rate. The attribute <code>unit</code> must be set to "Hz".
<Format>	complex real polar	Specifies how the binary data is saved in the I/Q data binary file (see <DataFilename> element). Every sample must be in the same format. The format can be one of the following: <ul style="list-style-type: none"> • <code>complex</code>: Complex number in cartesian format, i.e. I and Q values interleaved. I and Q are unitless • <code>real</code>: Real number (unitless) • <code>polar</code>: Complex number in polar format, i.e. magnitude (unitless) and phase (rad) values interleaved. Requires <code>DataType = float32 or float64</code>
<DataType>	int8 int16 int32 float32 float64	Specifies the binary format used for samples in the I/Q data binary file (see <DataFilename> element and Section A.3.1.2, "I/Q data binary file" , on page 171). The following data types are allowed: <ul style="list-style-type: none"> • <code>int8</code>: 8 bit signed integer data • <code>int16</code>: 16 bit signed integer data • <code>int32</code>: 32 bit signed integer data • <code>float32</code>: 32 bit floating point data (IEEE 754) • <code>float64</code>: 64 bit floating point data (IEEE 754)

Element	Possible Values	Description
<ScalingFactor>	double	Optional: describes how the binary data can be transformed into values in the unit Volt. The binary I/Q data itself has no unit. To get an I/Q sample in the unit Volt the saved samples have to be multiplied by the value of the <ScalingFactor>. For polar data only the magnitude value has to be multiplied. For multi-channel signals the <ScalingFactor> must be applied to all channels. The attribute <code>unit</code> must be set to "v". The <ScalingFactor> must be > 0. If the <ScalingFactor> element is not defined, a value of 1 V is assumed.
<NumberOfChannels>	integer	Optional: specifies the number of channels, e.g. of a MIMO signal, contained in the I/Q data binary file. For multi-channels, the I/Q samples of the channels are expected to be interleaved within the I/Q data file (see Section A.3.1.2, "I/Q data binary file" , on page 171). If the <NumberOfChannels> element is not defined, one channel is assumed.
<DataFilename>		Contains the filename of the I/Q data binary file that is part of the <code>iq-tar</code> file. It is recommended that the filename uses the following convention: <code><xyz>.<Format>.<Channels>ch.<Type></code> <ul style="list-style-type: none"> • <code><xyz></code> = a valid Windows file name • <code><Format></code> = complex, polar or real (see <code>Format</code> element) • <code><Channels></code> = Number of channels (see <code>NumberOfChannels</code> element) • <code><Type></code> = float32, float64, int8, int16, int32 or int64 (see <code>DataType</code> element) Examples: <ul style="list-style-type: none"> • <code>xyz.complex.1ch.float32</code> • <code>xyz.polar.1ch.float64</code> • <code>xyz.real.1ch.int16</code> • <code>xyz.complex.16ch.int8</code>
<UserData>	xml	Optional: contains user, application or device-specific XML data which is not part of the <code>iq-tar</code> specification. This element can be used to store additional information, e.g. the hardware configuration. User data must be valid XML content.
<PreviewData>	xml	Optional: contains further XML elements that provide a preview of the I/Q data. The preview data is determined by the routine that saves an <code>iq-tar</code> file (e.g. R&S FSWP). For the definition of this element refer to the <code>RsIqTar.xsd</code> schema. Note that the preview can be only displayed by current web browsers that have JavaScript enabled and if the XSLT stylesheet <code>open_IqTar_xml_file_in_web_browser.xslt</code> is available.

Example

The following example demonstrates the XML description inside the `iq-tar` file. Note that this preview is not supported by all web browsers.

Name	Type	Modified	Size	Ratio	Packed	Path
File.complex.1ch.float32	FLOAT32 File	19.02.2015 17:24	10.408	00%	10.752	
max.xml	XML Document	19.02.2015 17:24	38.541	00%	38.912	
open_IqTar_xml_file_in_web_browser.xslt	XSLT Stylesheet	19.02.2015 17:24	121.956	00%	122.368	

Open the xml file in a web browser. If the stylesheet `open_IqTar_xml_file_in_web_browser.xslt` is in the same directory, the web browser displays the xml file in a readable format.

max.xml (of .iq.tar file)

Description	
Saved by	VSE_1.10
Date & Time	2014-11-24 14:34:06
Sample rate	32 MHz
Number of samples	3200300
Duration of signal	100.009 ms
Data format	complex, float32
Data filename	File.complex.1ch.float32
Scaling factor	1 V

IQ Analyzer

Power vs time
y-axis: 10 dB /div
x-axis: 10 ms /div

Spectrum
y-axis: 10 dB /div
x-axis: 5 MHz /div

I/Q

```

<?xml version="1.0" encoding="UTF-8"?>
<?xml-stylesheet type="text/xsl" href="open_IqTar_xml_file_in_web_browser.xslt"?>
<RS_IQ_TAR_FileFormat fileFormatVersion="1" xsi:noNamespaceSchemaLocation=
"http://www.rohde-schwarz.com/file/RsIqTar.xsd" xmlns:xsi=
"http://www.w3.org/2001/XMLSchema-instance">
  <Name>VSE_1.10a 29 Beta</Name>
  <Comment></Comment>
  <DateTime>2015-02-19T15:24:58</DateTime>
  <Samples>1301</Samples>
  <Clock unit="Hz">32000000</Clock>
  <Format>complex</Format>
  <DataType>float32</DataType>
  <ScalingFactor unit="V">1</ScalingFactor>
  <NumberOfChannels>1</NumberOfChannels>
  <DataFilename>File.complex.1ch.float32</DataFilename>

  <UserData>
    <RohdeSchwarz>
      <DataImportExport_MandatoryData>
        <ChannelNames>
          <ChannelName>IQ Analyzer</ChannelName>
        </ChannelNames>
        <CenterFrequency unit="Hz">0</CenterFrequency>
      </DataImportExport_MandatoryData>
      <DataImportExport_OptionalData>
        <Key name="Ch1_NumberOfPostSamples">150</Key>
        <Key name="Ch1_NumberOfPreSamples">150</Key>
      </DataImportExport_OptionalData>
    </RohdeSchwarz>
  </UserData>

</RS_IQ_TAR_FileFormat>

```

Example: ScalingFactor

Data stored as int16 and a desired full scale voltage of 1 V

ScalingFactor = 1 V / maximum int16 value = 1 V / 2¹⁵ = 3.0517578125e-5 V

Scaling Factor	Numerical value	Numerical value x ScalingFactor
Minimum (negative) int16 value	- 2 ¹⁵ = - 32768	-1 V
Maximum (positive) int16 value	2 ¹⁵ -1= 32767	0.999969482421875 V

A.3.1.2 I/Q data binary file

The I/Q data is saved in binary format according to the format and data type specified in the XML file (see <Format> element and <DataType> element). To allow reading and writing of streamed I/Q data, all data is interleaved, i.e. complex values are interleaved pairs of I and Q values and multi-channel signals contain interleaved (complex)

samples for channel 0, channel 1, channel 2 etc. If the <NumberOfChannels> element is not defined, one channel is presumed.

Example: Element order for real data (1 channel)

```
I[0],           // Real sample 0
I[1],           // Real sample 1
I[2],           // Real sample 2
...
```

Example: Element order for complex cartesian data (1 channel)

```
I[0], Q[0],     // Real and imaginary part of complex sample 0
I[1], Q[1],     // Real and imaginary part of complex sample 1
I[2], Q[2],     // Real and imaginary part of complex sample 2
...
```

Example: Element order for complex polar data (1 channel)

```
Mag[0], Phi[0], // Magnitude and phase part of complex sample 0
Mag[1], Phi[1], // Magnitude and phase part of complex sample 1
Mag[2], Phi[2], // Magnitude and phase part of complex sample 2
...
```

Example: Element order for complex cartesian data (3 channels)

Complex data: I[channel no][time index], Q[channel no][time index]

```
I[0][0], Q[0][0], // Channel 0, Complex sample 0
I[1][0], Q[1][0], // Channel 1, Complex sample 0
I[2][0], Q[2][0], // Channel 2, Complex sample 0

I[0][1], Q[0][1], // Channel 0, Complex sample 1
I[1][1], Q[1][1], // Channel 1, Complex sample 1
I[2][1], Q[2][1], // Channel 2, Complex sample 1

I[0][2], Q[0][2], // Channel 0, Complex sample 2
I[1][2], Q[1][2], // Channel 1, Complex sample 2
I[2][2], Q[2][2], // Channel 2, Complex sample 2
...
```

Example: Element order for complex cartesian data (1 channel)

This example demonstrates how to store complex cartesian data in float32 format using MATLAB®.

```
% Save vector of complex cartesian I/Q data, i.e. iqiqli...
N = 100
iq = randn(1,N)+1j*randn(1,N)
fid = fopen('xyz.complex.float32','w');
for k=1:length(iq)
    fwrite(fid,single(real(iq(k))), 'float32');
```

```

    fwrite(fid, single(imag(iq(k))), 'float32');
end
fclose(fid)

```

Example: PreviewData in XML

```

<PreviewData>
  <ArrayOfChannel length="1">
    <Channel>
      <PowerVsTime>
        <Min>
          <ArrayOfFloat length="256">
            <float>-134</float>
            <float>-142</float>
            ...
            <float>-140</float>
          </ArrayOfFloat>
        </Min>
        <Max>
          <ArrayOfFloat length="256">
            <float>-70</float>
            <float>-71</float>
            ...
            <float>-69</float>
          </ArrayOfFloat>
        </Max>
      </PowerVsTime>
      <Spectrum>
        <Min>
          <ArrayOfFloat length="256">
            <float>-133</float>
            <float>-111</float>
            ...
            <float>-111</float>
          </ArrayOfFloat>
        </Min>
        <Max>
          <ArrayOfFloat length="256">
            <float>-67</float>
            <float>-69</float>
            ...
            <float>-70</float>
            <float>-69</float>
          </ArrayOfFloat>
        </Max>
      </Spectrum>
    </Channel>
  </ArrayOfChannel>
  <IQ>
    <Histogram width="64" height="64">0123456789...0</Histogram>
  </IQ>
</PreviewData>

```

```

    </ArrayOfChannel>
  </PreviewData>

```

A.3.2 CSV file format

CSV files contain I/Q data as comma-separated values. Additional metadata can be saved.

- [Mandatory data elements](#)..... 174
- [Optional data elements](#)..... 174
- [Example](#)..... 175
- [Simple CSV format](#)..... 176

A.3.2.1 Mandatory data elements

Parameter Name	Possible Values
Name	String
Comment	String
DateTime	Year-Month-DayTHour:Min:Sec
Format	complex
DataType	float32
NumberOfChannels	Integer
Ch<n>_ChannelName	String
Ch<n>_Samples	Integer
Ch<n>_Clock[Hz]	double
Ch<n>_CenterFrequency[Hz]	Double
IQ Data Header	<Channel Name>_I; <Channel Name>_Q (IQ data value)
-----	Double ; Double (IQ data I/Q pairs)

A.3.2.2 Optional data elements

Parameter name	Possible Values
Ch<n>_AttenuElecState	ON OFF
Ch<n>_AttenuElecValue[dB]	Integer
Ch<n>_AttenuMech[dB]	Integer
Ch<n>_CalibrationState	ON OFF
Ch<n>_DeviceHwInfo	String

Parameter name	Possible Values
Ch<n>_DeviceId	String
Ch<n>_DeviceOptions	String
Ch<n>_DeviceVersions	String
Ch<n>_FilterSettings	FLAT GAUSS OFF
Ch<n>_HighPassFilterState	ON OFF
Ch<n>_Impedance[Ohm]	50 75
Ch<n>_InputCoupling	AC DC
Ch<n>_InputPath	RF
Ch<n>_MeasBandwidth[Hz]	double
Ch<n>_NumberOfPostSamples	Integer
Ch<n>_NumberOfPreSamples	Integer
Ch<n>_PreampGain[dB]	Integer
Ch<n>_PreampState	ON OFF
Ch<n>_RefLevelOffset[dB]	Double
Ch<n>_RefLevel[dBm]	Double
Ch<n>_RefOscillatorInput	OFF ON
Ch<n>_RefOscillatorFreq[Hz]	Double
Ch<n>_TrgSource	Extern <1..4> I/Q Power IF Power RF Power Power Sensor Time
Ch<n>_TrgLevel[dB]	Double
Ch<n>_TrgHysteresis[dB]	Double
Ch<n>_TrgTpis[s]	Double
Ch<n>_TrgOffset[s]	Double
Ch<n>_TrgSlope	Rising Falling Rising/Falling
Ch<n>_TrgHoldoff[s]	Double
Ch<n>_TrgDropOut[s]	Double
Ch<n>_YigPreSelectorState	ON OFF

A.3.2.3 Example

```

DataImportExport_MandatoryData;
Name;ExampleFile
Comment;Example Comment
DateTime;2015-02-19T15:26:33
Format;complex
DataType;float32

```

```

NumberOfChannels;1
Ch1_ChannelName;Example_Channel
Ch1_Samples;10
Ch1_Clock[Hz];3,2000000E+007
Ch1_CenterFrequency[Hz];100,0000000E+007
DataImportExport_EndHeaderSection;
Example_Channel_I;Example_Channel_Q
-5,9390777E-006;-3,4644620E-006
9,8984629E-007;-8,4631858E-005
-5,9885701E-005;4,1078620E-005
2,0786772E-005;7,8692778E-005
-4,9492314E-006;-1,5095156E-004
1,6332464E-005;1,8312156E-005
-5,4936470E-005;4,5532928E-005
-4,8997390E-005;9,7004937E-005
-1,1383232E-005;4,5532928E-005
-8,2157239E-005;3,2170003E-005

```

A.3.2.4 Simple CSV format

The simple .CSV format contains I/Q data only, without any header or meta data. That is, the file contains only (I,Q) data pairs, separated by commas. Several streams of data can be provided in one file, one after the other.

Example:

```

7.0663854e-003,1.7059683e-005,
7.0817876e-003,7.5836733e-006,
7.0711789e-003,-1.2189972e-005,

```

A.3.3 IQW file format

IQW is a binary file format containing one channel of complex IQ data.

Format description details:

- IQDataFormat: Complex
- IQDataType: Float32
- Byte order: Intel
- Data order: IQIQIQ (I/Q paired or interleaved) or IIIQQQ (I/Q blocks, default)

Mandatory Data Elements

Only the binary I/Q data.

Optional Data Elements

None.

A.3.4 Matlab® v. 4 / v. 7.3 file format

In Matlab® files, channel-related information is stored in Matlab® variables with names starting with 'ChX_'. 'X' represents the number of the channel with a lower bound of 1, e.g. the variable Ch1_ChannelName contains the name of the first channel. The corresponding data is contained in ChX_Data.

Optional user data can be saved to variables named UserDataX, where 'x' starts at 0. The variable UserData_Count contains the number of UserData variables. For compatibility reasons user data needs to be saved as a 2xN char array, where the first row contains the key of the user data and the second row the actual value. Both rows must have the same column count and are therefore right-padded with white spaces.

Variables can be written to the *.mat files in arbitrary order.



The Matlab® v7.3. file format requires the Matlab® Compiler Runtime (MCR) to be installed on the system and registered in the PATH environment variable.

- [Mandatory data elements](#)..... 177
- [Optional data elements](#)..... 178
- [Example](#)..... 179
- [Simple matlab® format](#)..... 179

A.3.4.1 Mandatory data elements

Variable name	Class	Format / possible values
Name	char	
Comment	char	
DateTime	char	Year-Month-DayTHour:Min:Sec
Format	char	complex
DataType	char	float32
NumberOfChannels	Double	
Ch<n>_ChannelName	char	
Ch<n>_Samples	double	
Ch<n>_Clock_Hz	double	
Ch<n>_CFrequency_Hz	Double	
Ch<n>_Data	Double, Double	I,Q
UserData_Count	Double	(Number of optional user data variables)

A.3.4.2 Optional data elements

Optional user data can be saved to variables named `UserDataX`, where 'x' starts at 0. The variable `UserData_Count` contains the number of `UserData` variables. For compatibility reasons user data needs to be saved as a 2xN char array, where the first row contains the key of the user data and the second row the actual value. Both rows must have the same column count and are therefore right-padded with white spaces.

Variable name	Class	Format
<code>UserData<n></code>	char	Optional Data Parameter name, Value

Table A-2: Optional parameter names to be defined in `UserData<n>` variables

Parameter name	Possible Values
<code>Ch<n>_AttenuElecState</code>	ON OFF
<code>Ch<n>_AttenuElecValue_dB</code>	Integer
<code>Ch<n>_AttenuMech_dB</code>	Integer
<code>Ch<n>_CalibrationState</code>	ON OFF
<code>Ch<n>_DeviceHwInfo</code>	String
<code>Ch<n>_DeviceId</code>	String
<code>Ch<n>_DeviceOptions</code>	String
<code>Ch<n>_DeviceVersions</code>	String
<code>Ch<n>_FilterSettings</code>	FLAT GAUSS OFF
<code>Ch<n>_HighPassFilterState</code>	ON OFF
<code>Ch<n>_Impedance_Ohm</code>	50 75
<code>Ch<n>_InputCoupling</code>	AC DC
<code>Ch<n>_InputPath</code>	RF
<code>Ch<n>_MeasBandwidth_Hz</code>	double
<code>Ch<n>_NumberOfPostSamples</code>	Integer
<code>Ch<n>_NumberOfPreSamples</code>	Integer
<code>Ch<n>_PreampGain_dB</code>	Integer
<code>Ch<n>_PreampState</code>	ON OFF
<code>Ch<n>_RefLevelOffset_dB</code>	Double
<code>Ch<n>_RefLevel_dBm</code>	Double
<code>Ch<n>_RefOscillatorInput</code>	OFF ON
<code>Ch<n>_RefOscillatorFreq_Hz</code>	Double
<code>Ch<n>_TrgSource</code>	Extern <1..4> I/Q Power IF Power RF Power Power Sensor Time
<code>Ch<n>_TrgLevel_dB</code>	Double

Parameter name	Possible Values
Ch<n>_TrgHysteresis_dB	Double
Ch<n>_TrgTpis_s	Double
Ch<n>_TrgOffset_s	Double
Ch<n>_TrgSlope	Rising Falling Rising/Falling
Ch<n>_TrgHoldoff_s	Double
Ch<n>_TrgDropOut_s	Double
Ch<n>_YigPreSelectorState	ON OFF

A.3.4.3 Example

The screenshot shows a workspace window with a table of parameters. The table has columns for Name, Value, Size, Min, Max, Class, and Range. The parameters include Ch1_CFrequency_Hz, Ch1_ChannelName, Ch1_Clock_Hz, Ch1_Data, Ch1_Samples, Comment, DataType, DateTime, Format, Name, NumberOfChannels, and various UserData fields (UserData0 to UserData9 and UserData_Count).

Name	Value	Size	Min	Max	Class	Range
Ch1_CFrequency_Hz	4.0000e+09	1x1	4.0000...	4.0000...	double	0
Ch1_ChannelName	'IQ Analyzer'	1x11			char	
Ch1_Clock_Hz	32000000	1x1	32000...	32000...	double	0
Ch1_Data	<1301x2 double>	1301x2	-2.128...	2.6082...	double	4.7364e-04
Ch1_Samples	1301	1x1	1301	1301	double	0
Comment	''	1x0			char	
DataType	'float32'	1x7			char	
DateTime	'2015-02-19T15:25:58'	1x19			char	
Format	'complex'	1x7			char	
Name	'VSE_1.10a 29 Beta'	1x17			char	
NumberOfChannels	1	1x1	1	1	double	0
UserData0	<2x19 char>	2x19			char	
UserData1	<2x23 char>	2x23			char	
UserData10	<2x17 char>	2x17			char	
UserData11	<2x13 char>	2x13			char	
UserData12	<2x20 char>	2x20			char	
UserData13	<2x23 char>	2x23			char	
UserData14	<2x22 char>	2x22			char	
UserData15	<2x18 char>	2x18			char	
UserData16	<2x15 char>	2x15			char	
UserData17	<2x22 char>	2x22			char	
UserData18	<2x17 char>	2x17			char	
UserData19	<2x22 char>	2x22			char	
UserData2	<2x18 char>	2x18			char	
UserData20	<2x13 char>	2x13			char	
UserData21	<2x23 char>	2x23			char	
UserData3	<2x20 char>	2x20			char	
UserData4	<2x744 char>	2x744			char	
UserData5	<2x44 char>	2x44			char	
UserData6	<2x192 char>	2x192			char	
UserData7	<2x18 char>	2x18			char	
UserData8	<2x23 char>	2x23			char	
UserData9	<2x18 char>	2x18			char	
UserData_Count	22	1x1	22	22	double	0

A.3.4.4 Simple matlab® format

As of R&S FSWP software version 1.50, a simple `.mat` format is supported. This format contains I/Q data only, without any meta data. That is, the file contains only variables (double, double) for the corresponding channel data.



When you load a simple Matlab® file, you must define the used sample rate (and optionally analysis bandwidth) manually.

A.3.5 AID format

AID is a format used to transmit real or complex baseband signals. The IF signal is sent along with information that characterizes the datastream and datastream source.

All datastreams have a frame based structure using the same format, consisting of a global *Frame header* coupled with a data-type specific *Frame body* (i.e. the frame payload).

The header and the body of the frame consist of a number of 32-bit words. The *Frame header* has a predefined structure and size. The size and structure of the *Frame body* depends on the payload type. This is an important factor in the choice of the frame size.

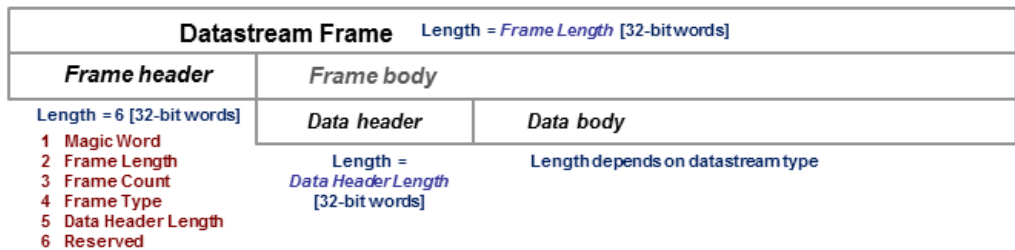

Figure A-2: Generic Datastream Frame structure

Global Frame header

The *Frame header* contains information used for frame synchronization, frame sequencing, payload identification and frame sizing. It consist of six 32-bit words as depicted in the following figure and is defined in

`rs_gx40x_global_frame_header_if_defs.h`

Table A-3: Global Frame header (structure name: *typFRH_FRAMEHEADER*)

Word position in frame	Member name Member type	Description
1	uintMagicWord ptypUINT	Magic Word - 32-bit word, always identical (0xFB746572), defines the start of the <i>Frame header</i> and is used for frame synchronization. The <i>Magic Word</i> and the <i>Frame Length</i> are used to identify the beginning of each frame.
2	uintFrameLength ptypUINT	Frame Length - gives the length of the frame including both <i>Frame header</i> and <i>Frame body</i> . The length is expressed in 32-bit words. The minimum length is six in case the <i>Frame body</i> is empty and the maximum length is limited to the value: <ul style="list-style-type: none"> • <code>kFRH_FRAME_LENGTH_MAX = 0x100000</code> ($1048576 = 2^{20}$) in case of normal frames • <code>kFRH_FRAME_LENGTH_MAX_EX = 0x400000</code> ($64 * 1048576 = 2^{26}$) in case of extended frames (an extended frame is marked by Bit#0 of the Reserved word of the frame header). Only some datastream types allow the extended frame size, see the definitions in the <code>rs_gx40x_global_frame_types_if_defs.h</code>. The next <i>Magic Word</i> which denotes the next frame in this data stream will occur <code>uintFrameLength</code> [32-bit words] after the <i>Magic Word</i> in this frame.
3	uintFrameCount ptypUINT	Frame Count - sequence counter modulo 2^{32} . Determines the position of this frame in the datastream and is used for sequencing and lost frame detection.
4	uintFrameType ptypUINT	Frame Type - identifies the data type contained in this frame and gives the specific structure of the frame payload. The complete list of frame types (i.e. datastream types) can be found in the following header file: <code>rs_gx40x_global_frame_types_if_defs.h</code>
5	uintDataHeaderLength ptypUINT	Data Header Length - gives the length of the <i>data header</i> positioned at the beginning of the <i>Frame body</i> . The length is expressed in 32-bit words (0 means no data header). This information can be used by the software to recognize the version of the datastream format and thus its compatibility to read and correctly interpret the datastream. It enables forward-compatibility with future datastream versions. This value will not vary for a continuous data stream.
6	uintReserved ptypUINT	<ul style="list-style-type: none"> • Bits #31 to #1 - Reserved (not yet used, must be 0) • Bit #0 - Marks the frame with extended size (up to <code>kFRH_FRAME_LENGTH_MAX_EX</code> 32-bit words).



The *Data Header Length* information is very important for the correct addressing of the data samples. This information gives the exact position in the frame where the *Data body* begins independent of the version of the *data header* (different versions consist of different number of parameters). From the frame beginning (indicated by the *Magic Word*), the first six 32-bit words represent the *Frame header* and the next *Data Header Length* 32-bit words represent the *data header*. After $6 + \text{uintDataHeaderLength}$ 32-bit words starts the *Data body*, i.e. the first data sample.

Frame body

The *Frame body* contains the payload of the frame and its structure depends on the datastream type, as defined by the *Frame Type* element in the *Frame header*.

The *Frame body* is structured into a *data header* followed by the *Data body*. The *data header* contains datastream specific information of the payload.



Bit numbering

Throughout this format description it is assumed that bit #0 is the bit of least numeric significance.

A.3.5.1 Data body

The IF Data format is valid for the following datastream types:

Table A-4: IF Datastream types

Datastream type ID	Description	Sample data type
ekFRH_DATASTREAM__IFDATA_32RE_32IM_FIX ekFRH_DATASTREAM__IFDATA_32RE_32IM_FIX_RESCALED	Complex IF Data samples, 32-bit real-part and 32-bit imaginary-part, fixed point	typIFD_SAMPLE_32RE_32IM_FIX
ekFRH_DATASTREAM__IFDATA_16RE_16IM_FIX	Complex IF Data samples, 16-bit real-part and 16-bit imaginary-part, fixed point	typIFD_SAMPLE_16RE_16IM_FIX
ekFRH_DATASTREAM__IFDATA_16RE_16RE_FIX	Real IF Data samples, 16-bit real-part, two samples in each 32-bit word, fixed point	typIFD_SAMPLE_16RE_16RE_FIX
ekFRH_DATASTREAM__IFDATA_32RE_32IM_FLOAT_RESCALED	Complex IF Data samples, 32-bit real-part und 32-bit imaginary-part, floating point	typIFD_SAMPLE_32RE_32IM_FLOAT

For the datastream types defined in [Table A-4](#), the same frame body structure is used, the only difference is the carried sample data type.

IF Data Frame Structure

The structure of the IF Datastream is defined in the `rs_gx40x_global_ifdata_header_if_defs.h` header file.

The Data Frame consists of the global *frame header* of type `typFRH_FRAMEHEADER`, as described in "[Global Frame header](#)" on page 180, followed by the datastream-specific *Frame body*.

The corresponding "Frame Type" value from the *frame header* for this datastream type can be found in the global frame types header file:

`rs_gx40x_global_frame_types_if_defs.h`.

The *frame body* consists of: the *data header* which describes the datastream payload and the *data body* which contains the actual datastream payload.

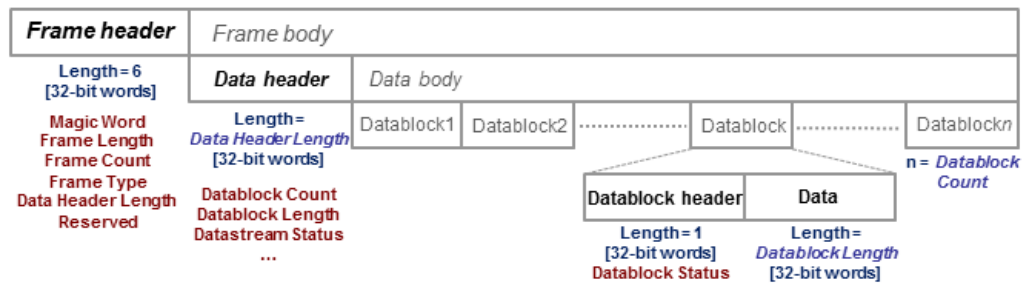

Figure A-3: IF Data frame format

IF data header

The data header describes the datastream payload (such as number of data samples contained in this frame), and contains common properties of the data samples.

The **basic** data header contains several fields that are always sent.

The **extended** data header contains extra information fields sent after the fields of the basic structure.

The length of the data header, as specified by the `uintDataHeaderLength` parameter from the frame header. This parameter provides information about which data header type is used - i.e. the basic header or the extended header.

The IF data header structure, of type `typIFD_IFDATAHEADER`, is described in the following table (data header length = 14 [32-bit words]).

Table A-5: IF DATA header (`typIFD_IFDATAHEADER`)

Word position in frame	Member name Member type	Description
7	<code>uintDatablockCount</code> <code>ptypUINT</code>	Datablock Count - represents the number of IF signal data blocks in the IF data frame.
8	<code>uintDatablockLength</code> <code>ptypUINT</code>	Datablock Length - The number 32-bit words in each IF signal data block excluding the data block header (has to be of the form 2^N with $N \geq 2$). This may not be the same as the number of IF signal data samples, as the size of a sample may be 16, 32 or 64 bits.
9 10	<code>bigtimeTimeStamp</code> <code>ptypBIGTIME</code>	64-bit Timestamp [μ s] - Absolute time of the first IF signal data sample, in the first data block of IF signal data in this frame.

Reference: supported I/Q file formats

Word position in frame	Member name Member type	Description
11	uintStatusword ptypUINT	<p>Status Word - extra information that help the receiver react by parameter changes.</p> <ul style="list-style-type: none"> • Bit #31 - Reserved • Bit #30 - dBFS flag <ul style="list-style-type: none"> – 1 indicates that all samples in this frame are considered to be dBFS (dB full scale). – 0 indicates that the values <i>Antenna Voltage Reference</i> and <i>Reciprocal gain correction</i> (see the <i>Status Word</i> description of the datablock header) can be used to calculate the corresponding level for each sample. • Bits #29 to #8 - Reserved (not yet used, must be 0) • Bits #7 to #0 - User flags for special signaling between IF Data processing components.
12	uintSignalSourceID ptypUINT	Signal Source Identifier or antenna identifier (value 0x0 if not used)
13	uintSignalSourceState ptypUINT	<p>Current Signal Source State (value 0x0 if not used)</p> <ul style="list-style-type: none"> • gives the <i>Configuration Set Identifier</i> of the Task Data Set (in GX400) currently being applied by the IF signal source OR • the current <i>Scan Step Number</i> in the case of scan operation In the case of memory scanning, the scan step number starts at 0 for the scan channel (memory location) configured with the lowest frequency, and increments (+1) for every channel configured for scanning in the memory scan list. In the case of frequency scanning, the scan step number starts at 0 for the scan step at the lowest frequency, and increments (+1) for every step taken within the configured frequency scan range.
14 15	uintTunerFrequency_Low uintTunerFrequency_High ptypUINT	64-bit Tuner Center Frequency [Hz] - least significant 32 bits (uintTunerFrequency_Low) followed by most significant 32 bits (uintTunerFrequency_High)

Word position in frame	Member name Member type	Description
16	uintBandwidth ptypUINT	IF signal 3dB Bandwidth [Hz]
17	uintSamplerate ptypUINT	Sample Rate of the AD Converter [samples / second] - due to digital filtering within the source, the resulting sample rate of the samples within this frame is: Sample Rate × Interpolation / Decimation
18	uintInterpolation ptypUINT	Interpolation Factor referred to the ADC signal sample rate. The value 0×1 indicates no interpolation
19	uintDecimation ptypUINT	Decimation Factor referred to the ADC signal sample rate. The value 0×1 indicates no decimation
20	intAntennaVoltageRef ptypINT	Antenna Voltage Reference (Ant-VoltRef) is the device specific correction value for the tuner front-end Rx attenuation (expresses anything from antenna input connector to ADC) and is expressed in [0.1 dBμV]. This is the level which, while the AGC amplification is at maximum attenuation, is required at the antenna input to produce the full scale value at the ADC. Using this value together with the Recip-Gain (Reciprocal Gain) value, one can calculate the true signal level at the antenna input connector (see "Data samples" on page 187). The RecipGain value is given in the Status Word of the IF Datablock header Table A-4

The extended IF data header structure, of type `typIFD_IFDATAHEADER_EX`, is described in the following table (total data header length = 19 [32-bit words]).

Table A-6: Extended IF data header (`typIFD_IFDATAHEADER_EX`) - extra fields only

Word position in frame	Member name Member type	Description
21 22	bigtimeStartTimeStamp ptypBIGTIME_NS	64-bit Timestamp [ns] - Absolute time of the first sample of the datastream since starting the datastream ("Sample Counter" == 0). This value remains constant until the datastream is stopped and started again or until the tuner performs an internal synchronization.
23 24	uintSampleCounter_Low uintSampleCounter_High ptypUINT	Sample Count - 64-bit counter from the first sample of the first datablock in this frame. Note that this value can be reset when the datastream is stopped and started again or when the tuner performs an internal synchronization. The Sample Count of the next IF frame can be deduced from Datablock Count, Datablock Length and the number of 32-bit words per sample. In this way the number of sample Dropouts can be estimated (that can be replaced with Null values). The exact time is given by $t = Start\ Time + Sample\ Count * Decimation / (Sample\ rate * Interpolation)$.
25	intKFactor ptypINT	kFactor - Correction factor of the current antenna, given in 0.1dB/m. Used to determine the field strength (in dBμV/m) at the antenna from the voltage level at the antenna input of the receiver. Contains antenna gain, cable attenuation, antenna switch matrix attenuation and anything else from air to antenna input. (the value 0x80000000 is used if no kFactor is defined).



The values contained in the data header fields represent the status at the beginning of the frame. A modification happening during the transmission of a frame will only be noted in the data header of the next frame.

IF Data Body

The IF data body contains zero or more IF Data samples arranged as an array of `typIFD_DATABLOCK` data blocks (the actual IF signal datastream payload). The number of datablocks is specified by the `Datablock Count` parameter from the data header.

Each datablock (`typIFD_DATABLOCK`) has its own datablock header: `datablockheaderDatablockHeader` (of type `typIFD_DATABLOCKHEADER`) and a datablock body that contains the actual data sample.

Table A-7: IF Datablock header (*typIFD_DATABLOCKHEADER*)

Member name Member type	Description
uintStatusword ptypUINT	Status of the Datablock <ul style="list-style-type: none"> • Bits #31 to #16 - RecipGain - Automatic Gain Control (AGC) Reciprocal Gain Correction value that was applied when generating the following IF Data samples. The RecipGain is represented as 16-bit unsigned decimal value (the 16-bit unsigned decimal has to be divided by $2^{16} = 65535$ to obtain the unsigned fractional between 0 and 1). For example a correction value of -17.5dB gives a value for RecipGain of 0.1333 which will be represented as $0x2220$. Using this value together with the value for the antenna voltage reference, one can calculate the true signal level at the antenna input connector (see "Data samples" on page 187). • Bits #15 to #8 - Reserved (must be 0). • Bits #7 to #2 - User flags for special signaling between IF Data processing components. Set to 0 if not used. • Bit #1 - Blanking flag - this flag is set (1) to indicate that the data in this block may have been falsified by some external event. • Bit #0 - Invalidity flag - this flag is set (1) to indicate that the data within this block may be corrupt (e.g. the input signal exceeded the range of the AD converter, or the analog signal input from which the data was converted was overloaded), OR any one of the fields in the IF datastream header does not represent the data in this block correctly.

The datablock body is defined as an array of size `uintDatablockLength` with `uintData` elements interpreted using the corresponding sample type format ("`typIFD_SAMPLE....`" as described in the following table). The actual IF data samples have to be extracted from the array. Their structure and size is given by the IF datastream format (Table A-4). The possible IF data sample formats are described in the table below:

Table A-8: IF data sample format

Sample type	Sample format	Most significant bits	Least significant bits	Data type
<code>typIFD_SAMPLE_32RE_32IM_FIX</code>	64-bit I/Q format	First 32-bit Real component		ptypINT or ptyp-FLOAT_SP
<code>typIFD_SAMPLE_32RE_32IM_FLOAT</code>		Second 32-bit Imaginary component		ptypINT or ptyp-FLOAT_SP
<code>typIFD_SAMPLE_16RE_16IM_FIX</code>	32-bit I/Q format	16-bit Imaginary component	16-bit Real component	ptypINT
<code>typIFD_SAMPLE_16RE_16RE_FIX</code>	16-bit Real format	16-bit sample number I+1	16-bit sample number I	ptypINT

The term 'fix' ('fixed' point) indicates signed (2s-complement) fixed point fractional numbers.

Data samples

The absolute signal level in [dBμV] may be calculated as follows:

$$\text{Level [dB}\mu\text{V]} = 10 \cdot \log(I_{\text{rel}}^2 + Q_{\text{rel}}^2) \text{ [dB]} + 20 \cdot \log(\text{RecipGain} / 2^{16}) \text{ [dB]} + 0.1 \cdot \text{AntVoltRef [dB}\mu\text{V]}$$

where I and Q are the real and imaginary parts of each signal sample.

The absolute signal level in [μV] may be calculated as follows:

$$I [\mu\text{V}] = I_{\text{rel}} * (\text{RecipGain} / 2^{16}) * \text{AntVoltLin}$$

$$Q [\mu\text{V}] = Q_{\text{rel}} * (\text{RecipGain} / 2^{16}) * \text{AntVoltLin}$$

$$\text{where AntVoltLin} [\mu\text{V}] = 10^{(0.1 * \text{AntVoltRef}) / 20}$$

Depending on the sample format, as presented in [Table A-8](#), I and Q values can be represented as signed integers on 32-bits (I_{int32}) or 16-bits (I_{int16}) or as 32-bit float values (I_{float}). The relative values of I and Q can be calculated with the following formulas (same applies for Q_{rel}):

- $I_{\text{rel}} = I_{\text{int32}} / (2^{31} - 1)$ where I_{int32} is a signed integer, the most significant bit gives the sign (0 is positive, 1 is negative)
- $I_{\text{rel}} = I_{\text{int16}} / (2^{15} - 1)$ where I_{int16} is a signed integer, the most significant bit gives the sign (0 is positive, 1 is negative)
- $I_{\text{rel}} = I_{\text{float}}$

In the first two cases I_{rel} and Q_{rel} represent relative signal level values between -1 and 1. The absolute signal levels are retrieved through the parameter AntVoltRef as presented above. In the third case, I_{rel} and Q_{rel} can represent directly the absolute signal levels - in this case the RecipGain and AntVoltRef are not used (and are set to RecipGain=1, AntVoltRef=0).

Example

Word position in frame	Frame component name	Hex value	Description
1	uintMagicWord	FB746572	Frame synchronisation
2	uintFrameLength	0000001E	Entire frame length = 30 (in 32-bit units)
3	uintFrameCount	000000FE	Running frame number = 254
4	uintFrameType	00000004	The type of data contained in this frame
5	uintDataHeaderLength	0000000E	data header length = 14 (in 32-bit units)
6	uintReserved	00000000	Reserved field
7	uintDatablockCount	00000002	Number of data blocks in this frame = 2
8	uintDatablockLength	00000004	The data block length (in 32-bit units) excluding the data block header = 4. Every data block in this frame will have the same length.
9 10	bigtimeTimeStamp	00035CED 1D63F4D0	Absolute time [μs] of the first IF signal data sample in this frame
11	uintStatusword	00000000	No status change indications.
12	uintSignalSourceID	00000003	Antenna ID = 3
13	uintSignalSourceState	00000A73	Tuner scan status = position 2675

Word position in frame	Frame component name	Hex value	Description
14	uintTunerFrequency_Low	42Ef9EC0	Tuner center frequency = 1,123 GHz
15	uintTunerFrequency_High	00000000	
16	uintBandwidth	01312d00	The IF Data bandwidth = 20 MHz
17	uintSamplerate	0493E000	ADC sample rate = 76,8 Msample/s
18	uintInterpolation	00000001	Interpolation factor = none
19	uintDecimation	00000003	Decimation factor referred to the ADC sample rate = 3
20	intAntennaVoltageRef	0000001E	Antenna reference voltage = 3dB μ V
21	uintStatusword	22200000	Beginning of the first Datablock. Statusword contains AGC correction factor = 0.1333 and no flags indications.
22	uintData	23873454	Real part of first sample
23	uintData	34234523	Imaginary part of first sample
24	uintData	56567543	Real part of second sample
25	uintData	34563456	Imaginary part of second sample
26	uintStatusword	41000004	Beginning of the second Datablock. Statusword contains AGC correction factor = 0.2539 and one user flag indication.
27	uintData	45345222	Real part of third sample
28	uintData	546672ab	Imaginary part of third sample
29	uintData	5BB25346	Real part of fourth sample
30	uintData	BBF7673e	Imaginary part of fourth sample

A.3.6 WV format

WV is a format used by Rohde & Schwarz signal generators to store waveforms. A waveform file contains a header and raw I/Q samples.

A.3.6.1 Mandatory elements

Each waveform file must begin with the TYPE tag. The sequence of the remaining tags is arbitrary.

Element	Description
TYPE	Designates the file type and source of creation (instrument type). Also includes an ASCII-coded checksum of the data part of the WAVEFORM tag, used to detect transmission errors.
CLOCK	The clock frequency (sample rate), in Hz

Element	Description
EMPTYTAG-Length	Length is an ASCII integer value that specifies the number of bytes in the EMPTYTAG, i.e. defines the number of bytes from the colon : to the end bracket }
WAVEFORM-Length	<p>The actual waveform data (I/Q stream)</p> <p>Length specifies the number of bytes in a WAVEFORM tag and is calculated as follows:</p> <p>Length = Number of I/Q pairs * 4 (2 bytes per I and 2 bytes per Q value) + 1 byte (the length of the #)</p> <p>The binary data is represented by 16-bit signed integer in 2's complement notation. It contains the I and Q component alternately, starting with the I component. Each component consists of 2 bytes in Little endian format representation, i.e. least significant byte (LSB) first. The values of the 2 bytes in an I component and a Q component are in the range 0x0 to 0xFFFF (-32767 to +32767).</p>

A.3.6.2 Optional elements

The following elements are optional in a .wv file.

Element	Description
DATE	Date and time at which the file was created Syntax: yyyy-mm-dd;hh:mm:ss
LEVEL OFFS	Offset of RMS and peak level relative to the 16-bit full scale modulation (-32767 to + 32767) = 0 dB.
SAMPLES	Number of I/Q samples in the waveform in ASCII format

List of Remote Commands (I/Q Analyzer)

[SENSe:]ADJust:ALL.....	146
[SENSe:]ADJust:CONFigure:HYSTeresis:LOWer.....	147
[SENSe:]ADJust:CONFigure:HYSTeresis:UPPer.....	147
[SENSe:]ADJust:CONFigure:LEVel:DURation.....	146
[SENSe:]ADJust:CONFigure:LEVel:DURation:MODE.....	146
[SENSe:]ADJust:CONFigure:TRIGger.....	147
[SENSe:]ADJust:FREQuency.....	148
[SENSe:]ADJust:LEVel.....	148
[SENSe:]AVERAge:COUNT.....	99
[SENSe:]AVERAge<n>[:STATe<t>].....	100
[SENSe:]FREQuency:CENTer.....	127
[SENSe:]FREQuency:CENTer:STEP.....	127
[SENSe:]FREQuency:CENTer:STEP:AUTO.....	128
[SENSe:]FREQuency:OFFSet.....	128
[SENSe:]IQ:BWIDth:MODE.....	138
[SENSe:]IQ:BWIDth:RESolution.....	138
[SENSe:]IQ:FFT:ALGorithm.....	139
[SENSe:]IQ:FFT:LENGth.....	139
[SENSe:]IQ:FFT:WINDow:LENGth.....	139
[SENSe:]IQ:FFT:WINDow:OVERlap.....	140
[SENSe:]IQ:FFT:WINDow:TYPE.....	140
[SENSe:]MSRA:CAPTure:OFFSet.....	140
[SENSe:]POWer:NCORrection.....	122
[SENSe:]SWAPiq.....	141
[SENSe:]SWEep:COUNT.....	100
[SENSe:]SWEep:COUNT:CURRent?.....	101
[SENSe:]SWEep:TIME.....	101
[SENSe:]SWEep[:WINDow<n>]:POINts.....	101
ABORT.....	95
CALCulate<n>:DELTAmarker<m>:X.....	112
CALCulate<n>:DELTAmarker<m>:Y?.....	113
CALCulate<n>:IQ:MODE.....	90
CALCulate<n>:MARKer<m>:FUNCTion:CENTer.....	126
CALCulate<n>:MARKer<m>:FUNCTion:FPEaks:SORT.....	111
CALCulate<n>:MARKer<m>:FUNCTion:FPEaks:X?.....	112
CALCulate<n>:MARKer<m>:FUNCTion:FPEaks:Y?.....	112
CALCulate<n>:MARKer<m>:FUNCTion:REFerence.....	120
CALCulate<n>:MARKer<m>:SEARCh.....	156
CALCulate<n>:MARKer<m>:X.....	113
CALCulate<n>:MARKer<m>:Y?.....	113
CALCulate<n>:SGRam:LAYout.....	156
CALCulate<n>:SGRam:TRACe.....	157
CALCulate<n>:SPECTrogram:LAYout.....	156
CALCulate<n>:SPECTrogram:TRACe.....	157
CALCulate<n>:UNIT:POWer.....	120
DIAGnostic:SERVice:NSOURce.....	119
DISPlay:FORMat.....	149

DISPlay[:WINDow<n>]:SIZE.....	149
DISPlay[:WINDow<n>][:SUBWindow<w>]:TRACe<t>:Y:SPACing.....	126
DISPlay[:WINDow<n>][:SUBWindow<w>]:TRACe<t>:Y[:SCALe].....	124
DISPlay[:WINDow<n>][:SUBWindow<w>]:TRACe<t>:Y[:SCALe]:AUTO ONCE.....	125
DISPlay[:WINDow<n>][:SUBWindow<w>]:TRACe<t>:Y[:SCALe]:MODE.....	125
DISPlay[:WINDow<n>][:SUBWindow<w>]:TRACe<t>:Y[:SCALe]:RLEVel.....	121
DISPlay[:WINDow<n>][:SUBWindow<w>]:TRACe<t>:Y[:SCALe]:RLEVel:OFFSet.....	121
DISPlay[:WINDow<n>][:SUBWindow<w>]:TRACe<t>:Y[:SCALe]:RPOSitioN.....	125
FORMat:DEXPort:CSEParator.....	108
FORMat:DEXPort:DSEParator.....	107
FORMat:DEXPort:FORMat.....	108
FORMat[:DATA].....	106
INITiate:SEQuencer:ABORT.....	98
INITiate:SEQuencer:IMMediate.....	98
INITiate:SEQuencer:MODE.....	99
INITiate:SEQuencer:REFResh[:ALL].....	99
INITiate<n>:CONMeas.....	96
INITiate<n>:CONTinuous.....	97
INITiate<n>[:IMMediate].....	98
INPut:ATTenuation.....	122
INPut:ATTenuation:AUTO.....	122
INPut:ATTenuation:AUTO:MODE.....	123
INPut:ATTenuation:PROTection:RESet.....	115
INPut:COUPling.....	115
INPut:FILE:PATH.....	115
INPut:FILTer:HPASs[:STATe].....	116
INPut:FILTer:YIG[:STATe].....	117
INPut:GAIN:STATe.....	123
INPut:GAIN[:VALue].....	124
INPut:IMPedance.....	117
INPut:IMPedance:PTYPE.....	117
INPut:SElect.....	118
INPut:UPORt:STATe.....	118
INPut:UPORt[:VALue].....	118
INSTRument:CREate:DUPLicate.....	90
INSTRument:CREate:REPLace.....	91
INSTRument:CREate[:NEW].....	90
INSTRument:DELeTe.....	91
INSTRument:LIST?.....	92
INSTRument:REName.....	92
INSTRument[:SElect].....	93
LAYout:ADD[:WINDow]?.....	149
LAYout:CATalog[:WINDow]?.....	151
LAYout:IDENtify[:WINDow]?.....	151
LAYout:REMOve[:WINDow].....	151
LAYout:REPLace[:WINDow].....	152
LAYout:SPLitter.....	152
LAYout:WINDow<n>:ADD?.....	154
LAYout:WINDow<n>:IDENtify?.....	154
LAYout:WINDow<n>:REMOve.....	155

LAYout:WINDow<n>:REPLace.....	155
MMEMory:LOAD:IQ:STATe.....	157
MMEMory:STORe<n>:IQ:COMMeNt.....	158
MMEMory:STORe<n>:IQ:STATe.....	158
MMEMory:STORe<n>:LIST.....	114
MMEMory:STORe<n>:TRACe.....	108
OUTPut:TRIGger<tp>:DIRectioN.....	133
OUTPut:TRIGger<tp>:LEVel.....	133
OUTPut:TRIGger<tp>:OTYPe.....	134
OUTPut:TRIGger<tp>:PULSe:IMMediate.....	134
OUTPut:TRIGger<tp>:PULSe:LENGth.....	135
OUTPut:UPORt:STATe.....	120
OUTPut:UPORt[:VALue].....	119
SYSTem:PRESet:CHANnel[:EXEC].....	93
SYSTem:SEQuencer.....	102
TRACe:IQ:AVERage:COUNT.....	99
TRACe:IQ:AVERage[:STATe].....	100
TRACe:IQ:BWIDth.....	141
TRACe:IQ:DATA:FORMat.....	104
TRACe:IQ:DATA:MEMory?.....	104
TRACe:IQ:DATA?.....	103
TRACe:IQ:EGATe:GAP.....	136
TRACe:IQ:EGATe:LENGth.....	136
TRACe:IQ:EGATe:NOF.....	137
TRACe:IQ:EGATe:TYPE.....	137
TRACe:IQ:EGATe[:STATe].....	136
TRACe:IQ:EVAL.....	94
TRACe:IQ:FILE:REPetition:COUNT.....	118
TRACe:IQ:RLENGth.....	141
TRACe:IQ:SET.....	142
TRACe:IQ:SRATe.....	143
TRACe:IQ:TPISamPle?.....	144
TRACe:IQ:WBANd:MBWIDth.....	144
TRACe:IQ:WBANd[:STATe].....	145
TRACe:IQ:WFILter.....	145
TRACe:IQ[:STATe].....	94
TRACe<n>[:DATA]:MEMory?.....	110
TRACe<n>[:DATA]:X?.....	111
TRACe<n>[:DATA]?.....	109
TRIGger[:SEQuence]:DTIME.....	129
TRIGger[:SEQuence]:HOLDoff[:TIME].....	129
TRIGger[:SEQuence]:IFPower:HOLDoff.....	129
TRIGger[:SEQuence]:IFPower:HYSteresis.....	130
TRIGger[:SEQuence]:LEVel:IFPower.....	130
TRIGger[:SEQuence]:LEVel:IQPower.....	131
TRIGger[:SEQuence]:LEVel:RFPower.....	131
TRIGger[:SEQuence]:LEVel[:EXtErnal<port>].....	130
TRIGger[:SEQuence]:SLOPe.....	131
TRIGger[:SEQuence]:SOURce.....	132
TRIGger[:SEQuence]:TIME:RINTerval.....	133

Index

Symbols

*OPC 128

A

Aborting
 Sweep 71, 72
 AC/DC coupling 47
 Activating
 I/Q Analyzer (remote) 89
 Amplitude
 Scaling 58
 Analysis
 Bandwidth 66
 Bandwidth, definition 25
 Interval (MSRA) 65
 Analysis line 38
 Application cards 11
 Application notes 11
 Applications
 I/Q Analyzer (remote) 89
 Att (channel setting) 16
 Attenuation
 Auto 55
 Manual 55
 Protective (remote) 115
 Auto adjustment
 Triggered measurement 147
 Auto all 73
 Auto frequency 73
 Auto level
 Hysteresis 74, 75
 Reference level 55, 74
 Softkey 55, 74
 Auto scaling 57
 Auto settings
 Meastime Auto 74
 Meastime Manual 74
 Average count 71

B

Bandwidth
 Analysis 66
 Extension options 25, 66
 I/Q Analyzer 25
 Maximum usable 25, 66
 Relationship to sample rate 26
 Settings 64
 Branch for peak search
 I/Q Analyzer 77
 Brochures 11

C

Capture offset
 MSRA secondary applications 70
 Remote 140
 Softkey 70
 Capture time
 see also Measurement time 101
 Capturing
 I/Q data, see Data acquisition 95

Center frequency 59
 Automatic configuration 73
 Displayed 16
 Softkey 59
 Step size 59
 Channel
 Creating (remote) 91, 93
 Deleting (remote) 91
 Duplicating (remote) 90
 Querying (remote) 92
 Renaming (remote) 92
 Replacing (remote) 91
 Selecting (remote) 93
 Closing
 Channels (remote) 91
 Windows (remote) 155
 Configuring
 Data acquisition (remote) 137
 I/Q Analyzer (remote) 114
 Continue single sweep
 Softkey 72
 Continuous sweep
 Softkey 71
 Conventions
 SCPI commands 83
 Copying
 Channel (remote) 90
 CP/ACLR
 Noise cancellation 56
 csv
 File format 165
 CSV
 Example file 175
 File format 174
 Mandatory data elements 174
 Optional data elements 174

D

 Data acquisition
 Configuring (remote) 137
 I/Q Analyzer 23
 I/Q data (remote) 95
 MSRA 65
 Settings 64
 Data format
 ASCII 163
 Binary 163
 Data sheets 11
 Decimal separator
 Trace export 45
 Decimation
 Data processing 23
 Demodulation
 Display 72
 Diagram area
 Hardware settings 16
 Diagram footer information 17
 Display configuration
 Softkey 72
 Drop-out time
 Trigger 64

- Duplicating
 - Channel (remote) 90
- E**
- Edge
 - Triggered gate 135
- Equalizer
 - Data processing 23
- Errors
 - IF OVLD 54
- Evaluation methods
 - Remote 149
- Exporting
 - Data 45
 - I/Q data 31, 40, 45, 80, 166, 171
 - Softkey 43
 - Traces 44, 45
- External trigger 61
 - Level (remote) 130
- F**
- FFT
 - Fundamentals 33
 - Measurement speed 36
 - Window functions 32, 69
- File types
 - CSV 174
 - IQW 176
 - Matlab® 177
 - Supported 165
- Files
 - Format, I/Q data 166
 - I/Q data binary XML 171
 - I/Q data input 29, 49
 - I/Q parameter XML 167
- Filters
 - Bandwidth, I/Q data 66
 - Equalizer 23
 - High-pass (RF input) 48
 - YIG (remote) 117
- Format
 - Data 163
 - I/Q data files 163
- Frame format
 - Data Header Length 181
 - Frame body 181
 - Frame Count 181
 - Frame Length 181
 - Frame Type 181
- Free Run
 - Trigger 61
- Frequency
 - Configuration (softkey) 58
 - Offset 59
- G**
- Gating
 - I/Q data 135
 - Source 61
- Getting started 10
- H**
- Hardware settings 16
 - Displayed 16
- High-pass filter
 - RF input 48
- Hysteresis
 - Lower (Auto level) 75
 - Trigger 63
 - Upper (Auto level) 74
- I**
- I/Q Analyzer
 - Data acquisition 23
 - Evaluation 18
 - I/Q Vector evaluation 19
 - Magnitude evaluation 18
 - Maximum bandwidth 25
 - Modes 89
 - Programming example 159, 160
 - Real/Imag (I/Q) evaluation 20
 - Results 18
 - Sample rate 25
 - Spectrum evaluation 19
- I/Q data
 - Analog, processing 23
 - Export file binary data description 171
 - Export file parameter description 167
 - Exporting 40, 45
 - Exporting/Importing 80
 - File format description 163
 - Importing 40, 43
 - Importing/Exporting 31
 - Input file 50
 - Input files 29, 49
 - Maximum bandwidth 25
 - Measurements in time and frequency domain 39
 - Sample rate 25
 - Trigger point in sample (TPIS) 144
 - Working with 79
- I/Q gating
 - Edge triggered 135
 - Level triggered 135
- I/Q measurements
 - Methods 95
- I/Q Power
 - Trigger 62
 - Trigger level (remote) 131
- I/Q Vector
 - Evaluation method 19
 - I/Q Analyzer 19
 - Y-axis scaling 58
- IF Data
 - Data header 183
 - Datablock header 187
 - Frame structure 182
 - Sample formats 187
- IF Power
 - Trigger 62
 - Trigger level (remote) 130
- IF WIDE OUTPUT
 - Connector 66
- Impedance
 - Setting 48

- Importing
 - I/Q data 31, 40, 43, 80, 167
 - Softkey 43
- Inherent noise
 - Cancellation 56
- Input
 - Coupling 47
 - I/Q data files 50
 - Overload (remote) 115
 - RF 47
- Input sample rate (ISR)
 - Definition 25
- Input sources
 - I/Q data file 50
 - I/Q data files 29, 49
- Installation 14
- Instrument security procedures 10
- iq-tar
 - Example file 169
 - Mandatory data elements 168
- iq.tar
 - File format 165
- IQBlock
 - I/Q data files 163
- IQPair
 - I/Q data files 163
- iqw
 - File format 165
- IQW
 - Example file 177
 - File format 176
 - Mandatory data elements 176
 - Optional data elements 176
- K**
- Keys
 - LINES (not used) 40
 - RUN CONT 71
 - RUN SINGLE 71, 72
- L**
- Level
 - Triggered gate 135
- Lower Level Hysteresis 75
- M**
- Magnitude
 - Evaluation method 18
 - I/Q Analyzer 18
- Marker table
 - Evaluation method 21
- Markers
 - Retrieving results (remote) 111
 - Table (evaluation method) 21
- matlab
 - File format 165
- Matlab®
 - Example file 179
 - File format 177
 - Mandatory data elements 177
 - Optional data elements 178
- Maximizing
 - Windows (remote) 149
- Meas Time (hardware setting) 16
- Measurement time
 - Auto settings 74
 - Displayed 16
 - I/Q data 67
 - Remote 101
- Modulation
 - Inverted (I/Q, remote) 141
 - Inverted (I/Q) 67
- MSRA
 - Analysis interval 65
 - Operating mode 38
- MSRA secondary applications
 - Capture offset (remote) 140
- Multiple
 - Channels 14
- N**
- Noise
 - Cancellation (CP/ACLR) 56
 - Cancellation (remote control) 122
 - Cancellation (softkey) 56
 - Correction, see Cancellation 56
 - Source 51
- O**
- Offset
 - Analysis interval 70
 - Displayed 16
 - Frequency 59
 - Reference level 54
- Options
 - Bandwidth extension 25, 66
 - High-pass filter 48
- Output
 - Noise source 51
 - Sample rate, definition 25
 - Trigger 51
- Overload
 - RF input (remote) 115
- Overview
 - Configuration 40
- P**
- Peak list
 - Evaluation method 22
- Peak search
 - Retrieving results (remote) 111
- Performance
 - FFT parameters 36
- Performing
 - I/Q Analyzer measurement 79
- Phase vs. Time
 - Evaluation method 21
- Ports
 - User 119
- Presetting
 - Channels 42
- Pretrigger 63
- Programming examples
 - I/Q Analyzer 159, 160
- Protection
 - RF input (remote) 115

R

Range	57
Scaling	57
RBW (hardware setting)	16
Real/Imag (I/Q)	
Evaluation method	20
I/Q Analyzer	20
Rec Length (hardware setting)	16
Record length	
Definition	25
I/Q data	67
Relationship to sample rate	26
Ref Level (hardware setting)	16
Reference level	54
Auto level	55, 74
Offset	54
Position	57
Unit	54
Value	54
Release notes	11
Remote commands	
Basics on syntax	83
Boolean values	87
Capitalization	84
Character data	87
Data blocks	87
Numeric values	86
Optional keywords	85
Parameters	85
Strings	87
Suffixes	84
Remote control	
Modes	89
Repetition interval	63
Resampler	
Data processing	23
Resetting	
RF input protection	115
Restoring	
Channel settings	42
Result displays	
I/Q Vector	19
Magnitude	18
Marker table	21
Peak list	22
Phase vs. Time	21
Real/Imag (I/Q)	20
Spectrum	19
Results	
I/Q Analyzer (remote)	102
Retrieving (remote)	102
RF attenuation	
Auto	55
Manual	55
RF input	
Overload protection (remote)	115
RF Power	
Trigger	62
Trigger level (remote)	131
RUN CONT	
Key	71
RUN SINGLE	
Key	71, 72

S

Safety instructions	11
Sample rate	
Definition	25
Displayed	16
I/Q Analyzer	25
I/Q data	65
Maximum	25
Relationship to bandwidth	26
Remote	143
Scaling	
Amplitude range, automatically	57
Y-axis	58
Y-axis (remote control)	126
Search settings	
I/Q Analyzer	77
Security procedures	10
Sequencer	14
Activating (remote)	98
Remote	97
Sequences	
Aborting (remote)	98
Mode (remote)	99
Service manual	10
Signal capturing	
Duration (remote)	101
Signal processing	
Diagram	24
Single sweep	
Softkey	71
Slope	
Trigger	64, 131
Softkeys	
Auto All	73
Auto Level	55, 74
Capture Offset	70
Center	59
Continue Single Sweep	72
Continuous Sweep	71
Display Config	72
Export	43
Export config	45
External	61
Free Run	61
Frequency Config	58
I/Q Export	45
I/Q Import	43
IF Power	62
Import	43
Lower Level Hysteresis	75
Meastime Auto	74
Meastime Manual	74
Noise cancellation	56
Ref Level	54
Ref Level Offset	54
RF Atten Auto	55
RF Atten Manual	55
RF Power	62
Single Sweep	71
Sweep Count	71
Time	63
Trigger Config	60
Trigger Offset	63
Upper Level Hysteresis	74
Specifics for	
Configuration	42

- Spectrograms
 - Activating/Deactivating 76
 - Size 76
- Spectrum
 - I/Q Analyzer 19
 - I/Q Evaluation method 19
- SRate (hardware setting) 16
- Status registers
 - Querying (remote) 158
 - STAT:QUES:POW 115
- Subwindows
 - Spectrogram 76
- Suffixes
 - Common 88
 - Remote commands 84
- Swap I/Q 67
 - Remote 141
- Sweep
 - Aborting 71, 72
 - Performing (remote) 95
 - Points (I/Q Analyzer) 70
 - Settings 70
 - Time (remote) 101
- Sweep Count 71
- T**
- Time trigger
 - Repetition interval 63
 - Softkey 63
- TPIS
 - I/Q data 144
- Traces
 - Export format 45
 - Exporting 44
 - Retrieving (remote) 103
- Trigger
 - Configuration (softkey) 60
 - Drop-out time 64
 - External (remote) 132
 - Holdoff 64
 - Hysteresis 63
 - Offset 63
 - Output 51
 - Slope 64, 131
- Trigger level 63
 - External trigger (remote) 130
 - I/Q Power (remote) 131
 - IF Power (remote) 130
 - RF Power (remote) 131
- Trigger source 61
 - External 61
 - Free Run 61
 - I/Q Power 62
 - IF Power 62
 - RF Power 62
 - Time 63
- Troubleshooting
 - Input overload 115
- U**
- Units
 - Reference level 54
- Upper Level Hysteresis 74
- Usable I/Q bandwidth
 - Definition 25
- User ports
 - Remote control 119
- User sample rate
 - Definition 25
- V**
- Videos 11
- W**
- White papers 11
- Window functions
 - Characteristics 33
 - FFT 32
- Window title bar information 16
- Windows
 - Adding (remote) 149
 - Closing (remote) 155
 - Configuring 42
 - Layout (remote) 152
 - Maximizing (remote) 149
 - Querying (remote) 151
 - Replacing (remote) 152
 - Splitting (remote) 149
 - Types (remote) 149
- Y**
- Y-axis
 - Scaling 58
 - Scaling (I/Q Vector) 58
- YIG-preselector
 - Activating/Deactivating 48
 - Activating/Deactivating (remote) 117