

R&S®FSW-K72/K73

3GPP FDD Measurements Options

User Manual

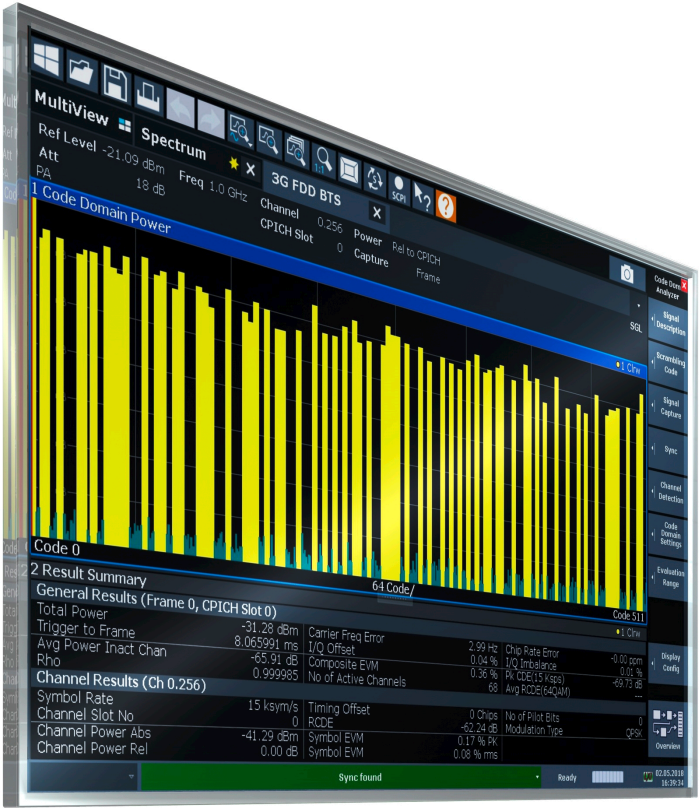

1173930502
Version 35



This manual applies to the following FSW models with firmware version 6.10 and later:

- R&S®FSW8 (1331.5003K08 / 1312.8000K08)
- R&S®FSW13 (1331.5003K13 / 1312.8000K13)
- R&S®FSW26 (1331.5003K26 / 1312.8000K26)
- R&S®FSW43 (1331.5003K43 / 1312.8000K43)
- R&S®FSW50 (1331.5003K50 / 1312.8000K50)
- R&S®FSW67 (1331.5003K67 / 1312.8000K67)
- R&S®FSW85 (1331.5003K85 / 1312.8000K85)

The following firmware options are described:

- R&S®FSW-K72 (1313.1422.02)
- R&S®FSW-K73 (1313.1439.02)

© 2024 Rohde & Schwarz

Muehldorfstr. 15, 81671 Muenchen, Germany

Phone: +49 89 41 29 - 0

Email: info@rohde-schwarz.com

Internet: www.rohde-schwarz.com

Subject to change – data without tolerance limits is not binding.

R&S® is a registered trademark of Rohde & Schwarz GmbH & Co. KG.

"WiMAX", "Mobile WiMAX", "Fixed WiMAX", "WiMAX Forum", "WiMAX Certified", "WiMAX Forum Certified", "WiGRID", the WiMAX Forum logo, the WiMAX Forum Certified logo and the WiGRID logo are trademarks or registered trademarks of the WiMAX Forum.

All other trademarks are the properties of their respective owners.

1173.9305.02 | Version 35 | R&S®FSW-K72/K73

Throughout this manual, products from Rohde & Schwarz are indicated without the ® symbol, e.g. R&S®FSW is indicated as R&S FSW. "R&S FSW-K72 and R&S FSW-K73" are indicated as R&S FSW-K72/K73.

Contents

1	Documentation overview.....	9
1.1	Getting started manual.....	9
1.2	User manuals and help.....	9
1.3	Service manual.....	9
1.4	Instrument security procedures.....	10
1.5	Printed safety instructions.....	10
1.6	Specifications and brochures.....	10
1.7	Release notes and open-source acknowledgment (OSA).....	10
1.8	Application notes, application cards, white papers, etc.....	11
1.9	Videos.....	11
2	Welcome to the 3GPP FDD applications.....	12
2.1	Starting the 3GPP FDD application.....	12
2.2	Understanding the display information.....	13
3	Measurements and result display.....	16
3.1	Code domain analysis.....	16
3.1.1	Code domain parameters.....	17
3.1.2	Evaluation methods for code domain analysis.....	19
3.1.3	CDA measurements in MSRA operating mode.....	34
3.2	Time alignment error measurements.....	34
3.3	RF measurements.....	35
3.3.1	RF measurement types and results.....	35
3.3.2	Evaluation methods for RF measurements.....	39
4	Measurement basics.....	42
4.1	Channel detection.....	45
4.2	BTS channel types.....	45
4.3	UE channel types.....	49
4.4	3GPP FDD BTS test models.....	50
4.5	Setup for base station tests.....	51
4.6	3GPP FDD UE test models.....	52
4.7	Setup for user equipment tests.....	53

4.8	Time alignment error measurements.....	54
4.8.1	Measurement setup for two antennas in a base station.....	55
4.8.2	Measurement setup for transmit signals from multiple base Stations.....	55
4.9	I/Q data import and export.....	56
4.10	CDA measurements in MSRA operating mode.....	57
5	Configuration.....	59
5.1	Result display.....	59
5.2	Code domain analysis.....	60
5.2.1	Configuration overview.....	61
5.2.2	Signal description.....	62
5.2.3	Data input and output settings.....	67
5.2.4	Frontend settings.....	74
5.2.5	Trigger settings.....	81
5.2.6	Signal capture (data acquisition).....	86
5.2.7	Application data (MSRA).....	89
5.2.8	Synchronization (BTS measurements only).....	89
5.2.9	Channel detection.....	91
5.2.10	Sweep settings.....	98
5.2.11	Automatic settings.....	100
5.3	Time alignment error measurements.....	102
5.3.1	Configuration overview.....	102
5.3.2	Carrier table configuration.....	104
5.4	RF measurements.....	108
5.4.1	Channel power (ACLR) measurements.....	109
5.4.2	Occupied bandwidth.....	110
5.4.3	Output power measurements.....	110
5.4.4	Spectrum emission mask.....	111
5.4.5	RF combi.....	111
5.4.6	CCDF.....	112
6	Analysis.....	114
6.1	Evaluation range.....	114
6.2	Code domain settings (BTS measurements).....	117
6.3	Code domain settings (UE measurements).....	119

6.4	Traces.....	120
6.5	Trace / data export configuration.....	122
6.6	Markers.....	123
6.6.1	Individual marker settings.....	124
6.6.2	General marker settings.....	125
6.6.3	Marker search settings.....	126
6.6.4	Marker positioning functions.....	127
7	I/Q data import and export.....	130
8	Optimizing and troubleshooting the measurement.....	131
8.1	Error messages.....	131
9	How to perform measurements in 3GPP FDD applications.....	132
10	Measurement examples.....	136
10.1	Measurement 1: measuring the signal channel power.....	136
10.2	Measurement 2: determining the spectrum emission mask.....	137
10.3	Measurement 3: measuring the relative code domain power.....	139
10.3.1	Synchronizing the reference frequencies.....	140
10.3.2	Behavior with deviating center frequency.....	141
10.3.3	Behavior with incorrect scrambling code.....	142
10.4	Measurement 4: triggered measurement of relative code domain power.....	143
10.5	Measurement 5: measuring the composite EVM.....	145
10.6	Measurement 6: determining the peak code domain error.....	146
11	Remote commands for 3GPP FDD measurements.....	149
11.1	Introduction.....	150
11.1.1	Conventions used in descriptions.....	150
11.1.2	Long and short form.....	151
11.1.3	Numeric suffixes.....	151
11.1.4	Optional keywords.....	151
11.1.5	Alternative keywords.....	152
11.1.6	SCPI parameters.....	152
11.2	Common suffixes.....	154
11.3	Activating 3GPP FDD measurements.....	155
11.4	Selecting a measurement.....	159

11.5	Configuring code domain analysis and time alignment error measurements....	161
11.5.1	Signal description.....	161
11.5.2	Configuring the data input and output.....	166
11.5.3	Frontend configuration.....	187
11.5.4	Configuring triggered measurements.....	196
11.5.5	Signal capturing.....	203
11.5.6	Synchronization.....	205
11.5.7	Channel detection.....	206
11.5.8	Sweep settings.....	218
11.5.9	Automatic settings.....	219
11.5.10	Evaluation range.....	223
11.5.11	Code domain analysis settings (BTS measurements).....	224
11.5.12	Code domain analysis settings (UE measurements).....	226
11.5.13	Configuring carrier tables for time alignment measurements.....	227
11.6	Configuring RF measurements.....	232
11.6.1	Special RF configuration commands.....	233
11.6.2	Analysis.....	233
11.7	Configuring the result display.....	233
11.7.1	General window commands.....	234
11.7.2	Working with windows in the display.....	234
11.8	Starting a measurement.....	242
11.9	Retrieving results.....	246
11.9.1	Retrieving calculated measurement results.....	247
11.9.2	Measurement results for TRACe<n>[:DATA]? TRACE<n>.....	251
11.9.3	Retrieving trace results.....	258
11.9.4	Exporting trace results.....	267
11.9.5	Retrieving RF results.....	269
11.10	Analysis.....	273
11.10.1	Traces.....	273
11.10.2	Markers.....	274
11.11	Importing and exporting I/Q data and results.....	284
11.12	Configuring the secondary application data range (MSRA mode only).....	286
11.13	Querying the status registers.....	288

11.14	Deprecated commands.....	291
11.15	Programming examples (FSW-k72).....	295
11.15.1	Measurement 1: measuring the signal channel power.....	296
11.15.2	Measurement 2: determining the spectrum emission mask.....	296
11.15.3	Measurement 3: measuring the relative code domain power.....	298
11.15.4	Measurement 4: triggered measurement of relative code domain power.....	300
11.15.5	Measurement 5: measuring the composite EVM.....	300
11.15.6	Measurement 6: determining the peak code domain error.....	301
	List of Commands (3GPP FDD).....	303
	Index.....	309

1 Documentation overview

This section provides an overview of the FSW user documentation. Unless specified otherwise, you find the documents at:

www.rohde-schwarz.com/manual/FSW

Further documents are available at:

www.rohde-schwarz.com/product/FSW

1.1 Getting started manual

Introduces the FSW and describes how to set up and start working with the product. Includes basic operations, typical measurement examples, and general information, e.g. safety instructions, etc.

A printed version is delivered with the instrument. A PDF version is available for download on the Internet.

1.2 User manuals and help

Separate user manuals are provided for the base unit and the firmware applications:

- Base unit manual
Contains the description of all instrument modes and functions. It also provides an introduction to remote control, a complete description of the remote control commands with programming examples, and information on maintenance, instrument interfaces and error messages. Includes the contents of the getting started manual.
- Firmware application manual
Contains the description of the specific functions of a firmware application, including remote control commands. Basic information on operating the FSW is not included.

The contents of the user manuals are available as help in the FSW. The help offers quick, context-sensitive access to the complete information for the base unit and the firmware applications.

All user manuals are also available for download or for immediate display on the Internet.

1.3 Service manual

Describes the performance test for checking the rated specifications, module replacement and repair, firmware update, troubleshooting and fault elimination, and contains mechanical drawings and spare part lists.

The service manual is available for registered users on the global Rohde & Schwarz information system (GLORIS):

<https://gloris.rohde-schwarz.com>

1.4 Instrument security procedures

Deals with security issues when working with the FSW in secure areas. It is available for download on the internet.

1.5 Printed safety instructions

Provides safety information in many languages. The printed document is delivered with the product.

1.6 Specifications and brochures

The specifications document, also known as the data sheet, contains the technical specifications of the FSW. It also lists the firmware applications and their order numbers, and optional accessories.

The brochure provides an overview of the instrument and deals with the specific characteristics.

See www.rohde-schwarz.com/brochure-datasheet/FSW

1.7 Release notes and open-source acknowledgment (OSA)

The release notes list new features, improvements and known issues of the current software version, and describe the software installation.

The software uses several valuable open source software packages. An open source acknowledgment document provides verbatim license texts of the used open source software.

See www.rohde-schwarz.com/firmware/FSW

1.8 Application notes, application cards, white papers, etc.

These documents deal with special applications or background information on particular topics.

See www.rohde-schwarz.com/application/FSW

1.9 Videos

Find various videos on Rohde & Schwarz products and test and measurement topics on YouTube: <https://www.youtube.com/@RohdeundSchwarz>

2 Welcome to the 3GPP FDD applications

The 3GPP FDD applications add functionality to the FSW to perform code domain analysis or power measurements according to the 3GPP standard (FDD mode). The application firmware is in line with the 3GPP standard (Third Generation Partnership Project) with Release 5. Signals that meet the conditions for channel configuration of test models 1 to 4 according to the 3GPP standard, e.g. W-CDMA signals using FDD, can be measured with the 3GPP FDD BTS application. In addition to the code domain measurements specified by the 3GPP standard, the application firmware offers measurements with predefined settings in the frequency domain, e.g. power and ACLR measurements.

FSW-K72 performs **Base Transceiver Station (BTS)** measurements (for downlink signals).

FSW-K73 performs **User Equipment (UE)** measurements (for uplink signals).

In particular, the 3GPP FDD applications feature:

- Code domain analysis, providing results like code domain power, EVM, peak code domain error etc.
- Time alignment error determination
- Various power measurements
- "Spectrum Emission Mask" measurements
- Statistical ("CCDF") evaluation

This user manual contains a description of the functionality that the application provides, including remote control operation.

Functions that are not discussed in this manual are the same as in the Spectrum application and are described in the FSW User Manual. The latest version is available for download at the product homepage

<http://www.rohde-schwarz.com/product/FSW.html>.

Installation

You can find detailed installation instructions in the FSW Getting Started manual or in the Release Notes.

2.1 Starting the 3GPP FDD application

The 3GPP FDD measurements require a special application on the FSW.

To activate the 3GPP FDD applications

1. Select [MODE].

A dialog box opens that contains all operating modes and applications currently available on your FSW.

2. Select the "3GPP FDD BTS" or "3GPP FDD UE" item.



The FSW opens a new measurement channel for the 3GPP FDD application.

A Code Domain Analysis measurement is started immediately with the default settings. It can be configured in the 3GPP FDD "Overview" dialog box, which is displayed when you select "Overview" from any menu (see [Chapter 5.2.1, "Configuration overview"](#), on page 61).

Multiple Measurement Channels and Sequencer Function

When you activate an application, a new measurement channel is created which determines the measurement settings for that application. The same application can be activated with different measurement settings by creating several channels for the same application.

Only one measurement can be performed at any time, namely the one in the currently active channel. However, in order to perform the configured measurements consecutively, a Sequencer function is provided.

If activated, the measurements configured in the currently active channels are performed one after the other in the order of the tabs. The currently active measurement is indicated by a gear symbol in the tab label. The result displays of the individual channels are updated in the tabs (including the "MultiView") as the measurements are performed. Sequential operation itself is independent of the currently *displayed* tab.

For details on the Sequencer function see the FSW User Manual.

2.2 Understanding the display information

The following figure shows a measurement diagram during a 3GPP FDD BTS measurement. All different information areas are labeled. They are explained in more detail in the following sections.

(The basic screen elements are identical for 3GPP FDD UE measurements)

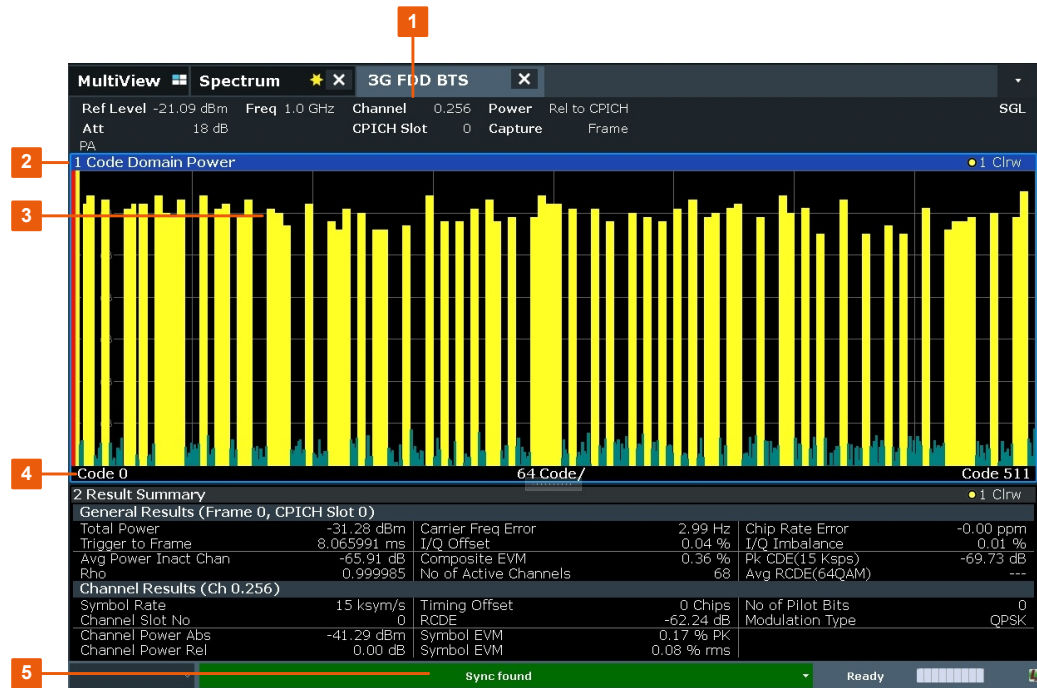

- 1 = Channel bar for firmware and measurement settings
- 2 = Window title bar with diagram-specific (trace) information
- 3 = Diagram area
- 4 = Diagram footer with diagram-specific information
- 5 = Instrument status bar with error messages, progress bar and date/time display



MSRA operating mode

In MSRA operating mode, additional tabs and elements are available. A colored background of the screen behind the measurement channel tabs indicates that you are in MSRA operating mode.

For details on the MSRA operating mode see the FSW MSRA User Manual.

Channel bar information

In 3GPP FDD applications, when performing Code Domain Analysis, the FSW screen display deviates from the Spectrum application. For RF measurements, the familiar settings are displayed (see the FSW Getting Started manual).

Table 2-1: Hardware settings displayed in the channel bar in 3GPP FDD applications for Code Domain Analysis

Ref Level	Reference level
Att	Mechanical and electronic RF attenuation
Freq	Center frequency for the RF signal
Channel	Channel number (code number and spreading factor)
CPICH Slot / Slot (UE)	Slot of the (CPICH) channel

Power	Power result mode: <ul style="list-style-type: none"> • Absolute • Relative to CPICH (BTS application (K72) only) • Relative to total power
SymbRate	Symbol rate of the current channel
Capture	(UE application (K73) only): basis for analysis (slot or frame)

Window title bar information

For each diagram, the header provides the following information:



Figure 2-1: Window title bar information in 3GPP applications

- 1 = Window number
- 2 = Window type
- 3 = Trace color
- 4 = Trace number
- 5 = Detector

Diagram footer information

For most graphical evaluations the diagram footer (beneath the diagram) contains scaling information for the x-axis, where applicable:

- Start channel/chip/frame/slot
- Channel/chip/frame/slot per division
- Stop channel/chip/frame/slot

For the **Bitstream** evaluation, the diagram footer indicates:

- Channel format (type and modulation type (HS-PDSCH only))
- Number of data bits
- Number of TPC bits
- Number of TFCI bits
- Number of pilot bits

(The bit numbers are indicated in the order they occur.)

Status bar information

Global instrument settings, the instrument status and any irregularities are indicated in the status bar beneath the diagram. Furthermore, the progress of the current operation is displayed in the status bar.

3 Measurements and result display

The 3GPP FDD applications provide several different measurements for signals according to the 3GPP FDD standard. The main and default measurement is "Code Domain Analysis". Furthermore, a "Time Alignment Error" measurement is provided.

In addition to the code domain power measurements specified by the 3GPP standard, the 3GPP FDD options offer measurements with predefined settings in the frequency domain, e.g. RF power measurements.

Evaluation methods

The captured and processed data for each measurement can be evaluated with various different methods. All evaluation methods available for the selected 3GPP FDD measurement are displayed in the evaluation bar in SmartGrid mode.

Evaluation range

You can restrict evaluation to a specific channel, frame or slot, depending on the evaluation method. See [Chapter 6.1, "Evaluation range"](#), on page 114.

- [Code domain analysis](#)..... 16
- [Time alignment error measurements](#)..... 34
- [RF measurements](#).....35

3.1 Code domain analysis

Access: [MEAS] > "Code Domain Analyzer"

The "Code Domain Analysis" measurement provides various evaluation methods and result diagrams.

The code domain power measurements are performed as specified by the 3GPP standards. A signal section of approximately 20 ms is recorded for analysis and then searched through to find the start of a 3GPP FDD frame. If a frame start is found in the signal, the code domain power analysis is performed for a complete frame starting from slot 0. The different evaluations are calculated from the captured I/Q data set. Therefore it is not necessary to start a new measurement to change the evaluation.

The 3GPP FDD applications provide the peak code domain error measurement and composite EVM specified by the 3GPP standard, as well as the code domain power measurement of assigned and unassigned codes. The power can be displayed either for all channels in one slot, or for one channel in all slots. The composite constellation diagram of the entire signal can also be displayed. In addition, the symbols demodulated in a slot, their power, and the determined bits or the symbol EVM can be displayed for an active channel.

The power of a code channel is always measured in relation to its symbol rate within the code domain. It can be displayed either as absolute values or relative to the total signal or the CPICH channel. By default, the power relative to the CPICH channel is displayed. The total power can vary depending on the slot, since the power can be

controlled on a per-slot-basis. The power in the CPICH channel, on the other hand, is constant in all slots.

For all measurements performed in a slot of a selected channel (bits, symbols, symbol power, EVM), the actual slot spacing of the channel is taken as a basis, rather than the CPICH slots. The time reference for the start of a slot is the CPICH slot. If code channels contain a timing offset, the start of a specific slot of the channel differs from the start of the reference channel (CPICH). Thus, the power-per-channel display is possibly not correct. If channels with a timing offset contain a power control circuit, the channel-power-versus-time display can possibly provide better results.

The composite EVM, peak code domain error and composite constellation measurements are always referenced to the total signal.

Remote command:

CONF:WCDP:MEAS WCDP, see [CONFIGure:WCDPower\[:BTS\]:MEASurement](#) on page 159

3.1.1 Code domain parameters

Two different types of measurement results are determined and displayed in the "Result Summary": global results and channel results (for the selected channel).



The number of the CPICH slot at which the measurement is performed is indicated globally for the measurement in the channel bar.

The spreading code of the selected channel is indicated with the channel number in the channel bar and above the channel-specific results in the "Result Summary".

In the "Channel Table", the analysis results for all active channels are displayed.

Table 3-1: General code domain power results for a specific frame and slot

Parameter	Description
Total Power:	The total signal power (average power of total evaluated slot).
Carrier Freq Error:	The frequency error relative to the center frequency of the analyzer. The absolute frequency error is the sum of the analyzer and DUT frequency error. The specified value is averaged for one (CPICH) slot. See also the note on " Carrier Frequency Error " on page 18.
Chip Rate Error:	The chip rate error in the frame to analyze in ppm. As a result of a high chip rate error, symbol errors arise and the CDP measurement is possibly not synchronized to the 3GPP FDD BTS signal. The result is valid even if synchronization of the analyzer and signal failed.
Trigger to Frame:	The time difference between the beginning of the recorded signal section to the start of the analyzed frame. For triggered data collection, this difference is identical to the time difference of frame trigger (+ trigger offset) – frame start. If synchronization of the analyzer and input signal fails, the value of "Trigger to Frame" is not significant.
IQ Offset:	DC offset of the signal in the selected slot in %
IQ Imbalance:	I/Q imbalance of signals in the selected slot in %

Parameter	Description
Avg Power Inact Chan	Average power of the inactive channels
"Composite EVM":	The composite EVM is the difference between the test signal and the ideal reference signal in the selected slot in %. See also "Composite EVM" on page 24
Pk CDE (15 ksps):	The "Peak Code Domain Error" projects the difference between the test signal and the ideal reference signal onto the selected spreading factor in the selected slot (see "Peak Code Domain Error" on page 28). The spreading factor onto which projection is performed can be derived from the symbol rate indicated in brackets.
RHO	Quality parameter RHO for each slot.
No of Active Chan:	The number of active channels detected in the signal in the selected slot. Both the detected data channels and the control channels are considered active channels.
Avg. RCDE	Average Relative Code Domain Error over all channels detected with 64 QAM (UE: 4PAM) modulation in the selected frame.



Carrier Frequency Error

The maximum frequency error that can be compensated is specified in [Table 3-2](#) as a function of the synchronization mode. Transmitter and receiver should be synchronized as far as possible.

Table 3-2: Maximum frequency error that can be compensated

SYNC mode	ANTENNA DIV	Max. Freq. Offset
CPICH	X	5.0 kHz
SCH	OFF	1.6 kHz
SCH	ANT 1	330 Hz
SCH	ANT 2	330 Hz

Table 3-3: Channel-specific code domain power results

Symbol Rate:	Symbol rate at which the channel is transmitted
Channel Slot No:	(BTS measurements only): Channel slot number; determined by combining the value of the selected CPICH and the channel's timing offset
Channel Mapping	(UE measurements only): Branch onto which the channel is mapped (I or Q, specified by the standard)
Chan Power Abs:	Channel power, absolute
Chan Power Rel:	Channel power, relative (referenced to CPICH or total signal power)
Timing Offset:	Offset between the start of the first slot in the channel and the start of the analyzed 3GPP FDD BTS frame
RCDE	Relative Code Domain Error for the complete frame of the selected channel
"Symbol EVM":	Peak and average of the results of the error vector magnitude evaluation

No of Pilot Bits:	Number of pilot bits of the selected channel
Modulation Type:	<p>BTS measurements:</p> <p>Modulation type of an HSDPA channel. High-speed physical data channels can be modulated with QPSK, 16 QAM or 64 QAM modulation.</p> <p>UE measurements: the modulation type of the selected channel. Valid entries are:</p> <ul style="list-style-type: none"> • BPSK I for channels on I-branch • BPSK Q for channels on Q-branch • NONE for inactive channels

3.1.2 Evaluation methods for code domain analysis



Access: "Overview" > "Display Config"

The captured I/Q data can be evaluated using various different methods without having to start a new measurement.

The selected evaluation also affects the results of the trace data query (see [Chapter 11.9.2, "Measurement results for TRACe<n>\[:DATA\]? TRACE<n>"](#), on page 251).

Bitstream.....	19
Channel Table.....	20
└ Table Configuration.....	21
Code Domain Power.....	22
Code Domain Error Power.....	23
Composite Constellation.....	23
Composite EVM.....	24
EVM vs Chip.....	25
Frequency Error vs Slot.....	26
Magnitude Error vs Chip.....	26
Marker Table.....	27
Peak Code Domain Error.....	28
Phase Discontinuity vs Slot.....	28
Phase Error vs Chip.....	29
Power vs Slot.....	30
Power vs Symbol.....	31
Result Summary.....	31
Symbol Constellation.....	32
Symbol EVM.....	32
Symbol Magnitude Error.....	33
Symbol Phase Error.....	33

Bitstream

The "Bitstream" evaluation displays the demodulated bits of a selected channel for a given slot. Depending on the symbol rate, the number of symbols within a slot can vary from 12 (min) to 384 (max). For QPSK modulation, a symbol consists of 2 bits (I and Q). For BPSK modulation, a symbol consists of 1 bit (only I used).

4 Bitstream Table											
	0	2	4	6	8	10	12	14	16	18	20
0	00	00	00	00	00	00	00	00	00	00	
22											
44											
66											
88											
110											
132											
154											
176											
198											
220											
	CPICH	20xD1		0xTPC	0xTFCI		0xD2		0xPil		

Figure 3-1: Bitstream display for 3GPP FDD BTS measurements

TIP: Select a specific symbol using the **MKR key** while the display is focused. If you enter a number, the marker jumps to the selected symbol, which is highlighted by a blue circle.

The diagram footer indicates:

- Channel format (type and modulation type (HS-PDSCH only))
- Number of data bits (D1 / D2)
- Number of TPC bits (TPC)
- Number of TFCI bits (TFCI)
- Number of pilot bits (Pil)

Remote command:

LAY:ADD? '1',RIGH, BITS, see [LAYout:ADD\[:WINDow\]?](#) on page 235
[TRACe<n>\[:DATA\]? ABITstream](#)

Channel Table

The "Channel Table" evaluation displays the detected channels and the results of the code domain power measurement. The channel table can contain a maximum of 512 entries.

In BTS measurements, this number corresponds to the 512 codes that can be assigned within the class of spreading factor 512.

In UE measurements, this number corresponds to the 256 codes that can be assigned within the class of spreading factor 256, with both I and Q branches.

The first entries of the table indicate the channels that must be available in the signal to be analyzed and any other control channels (see [Chapter 4.2, "BTS channel types"](#), on page 45 and [Chapter 4.3, "UE channel types"](#), on page 49).

The lower part of the table indicates the data channels that are contained in the signal.

If the type of a channel can be fully recognized, based on pilot sequences or modulation type, the type is indicated in the table. In BTS measurements, all other channels are of type CHAN.

The channels are in descending order according to symbol rates and, within a symbol rate, in ascending order according to the channel numbers. Therefore, the unassigned codes are always displayed at the end of the table.

Chan Type	Ch.SF	SymRate [ksp/s]	State	TFCI	PilotL [Bits]	PwrAbs [dBm]	PwrRel [dB]	Toffs [Chips]
CPICH	0.256	15	ON	OFF	0	-34.47	0.00	0.00
PSCH		0	ON	OFF	0	-37.74	-3.27	0.00
SSCH		0	ON	OFF	0	-37.06	-2.59	0.00
PCCPCH	1.256	15	ON	OFF	0	-34.38	0.09	0.00
SCCPCH	3.256	15	ON	OFF	0	-42.32	-7.85	0.00
PICH	16.256	15	ON	OFF	0	-42.26	-7.79	30720.0
HSPDSCH-16QAM	4.16	240	ON	OFF	0	-28.30	6.17	0.00
HSPDSCH-16QAM	12.16	240	ON	OFF	0	-28.56	5.91	0.00
HSSSCH	9.128	30	ON	OFF	0	-38.40	-3.93	0.00
DPCH	15.128	30	ON	OFF	8	-40.38	-5.91	22016.0
DPCH	23.128	30	ON	OFF	8	-38.32	-3.85	34304.0
HSSSCH	29.128	30	ON	OFF	0	-44.38	-9.91	0.00
DPCH	68.128	30	ON	OFF	8	-38.46	-3.99	13312.0
DPCH	76.128	30	ON	OFF	8	-41.38	-6.91	11520.0

Figure 3-2: Channel Table display for 3GPP FDD BTS measurements

Remote command:

LAY:ADD? '1',RIGH, CTABLE, see LAYOUT:ADD[:WINDOW]? on page 235

TRACe<n>[:DATA]? CTABLE

TRACe<n>[:DATA]? PWCDp

TRACe<n>[:DATA]? CWCDp

Table Configuration ← Channel Table

You can configure which parameters are displayed in the "Channel Table" by clicking (not double-clicking!) a column header.

A "Table Configuration" dialog box is displayed in which you can select the columns to be displayed.



By default, only active channels are displayed. To display all channels, including the inactive ones, enable the "Show Inactive Channels" option.

The following parameters of the detected channels are determined by the CDP measurement and can be displayed in the "Channel Table" evaluation. (For details see [Chapter 3.1.1, "Code domain parameters"](#), on page 17.)

Table 3-4: Code domain power results in the channel table

Label	Description
Chan Type	Type of channel (active channels only)
Ch. SF	Number of channel spreading code (0 to [spreading factor-1])
Symbol Rate [ksps]	Symbol rate at which the channel is transmitted In BTS measurements: always
State	Active: channel is active and all pilot symbols are correct Inactive: channel is not active Pilotf: channel is active, but pilot symbols incomplete or missing
TFCI	(BTS measurements only): Data channel uses TFCI symbols
Mapping	(UE measurements only): Branch the channel is mapped to (I or Q)
PilotL [Bits]	Number of pilot bits in the channel (UE measurements: only for control channel DPCCH)
Pwr Abs [dBm]/Pwr Rel [dBm]	Absolute and relative channel power (referred to the CPICH or the total power of the signal)
T Offs [Chips]	(BTS measurements only): Timing offset

Code Domain Power

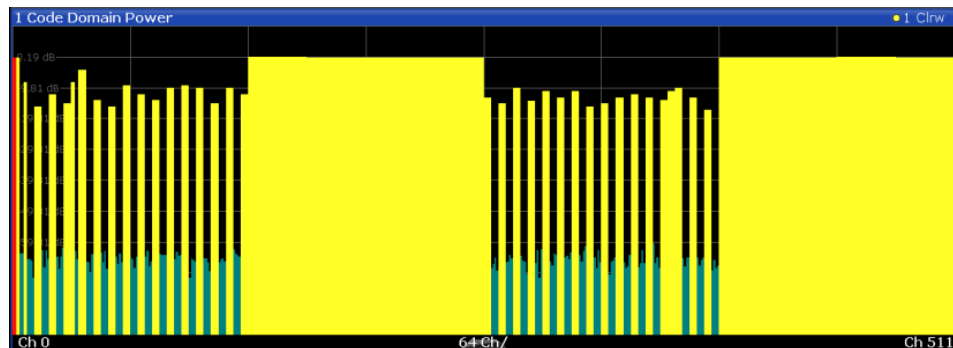

Figure 3-3: Code Domain Power Display for 3GPP FDD BTS measurements

The "Code Domain Power" evaluation shows the power of all possible code channels in the selected channel slot. The x-axis shows the possible code channels from 0 to the highest spreading factor. Due to the circumstance that the power is regulated from slot to slot, the result power can differ between different slots. Detected channels are displayed yellow. The selected code channel is highlighted red. The codes where no channel could be detected are displayed green.

Note: Effects of missing or incomplete pilot symbols. In "Autosearch" channel detection mode, the application expects specific pilot symbols for DPCH channels. If these symbols are missing or incomplete, the channel power in the "Code Domain Power" evaluation is displayed green at the points of the diagram the channel should appear due to its spreading code. Furthermore, a message ("INCORRECT PILOT") is displayed in

the status bar. In this case, check the pilot symbols for those channels using the "Power vs Slot" or the "Bitstream" evaluations.

Optionally, all QPSK-modulated channels can also be recognized without pilot symbols (see "HSDPA/UPA" on page 63).

Remote command:

LAY:ADD? '1',RIGH, CDPower, see LAYout:ADD[:WINDow]? on page 235

CALC:MARK:FUNC:WCDP:RES? CDP, see CALCulate<n>:MARKer<m>:FUNCTION:WCDPower[:BTS]:RESult on page 250

CALC:MARK:FUNC:WCDP:MS:RES? CDP, see CALCulate<n>:MARKer<m>:FUNCTION:WCDPower:MS:RESult? on page 248

TRACe<n>[:DATA]? CTABLE

TRACe<n>[:DATA]? PWCDp

TRACe<n>[:DATA]? CWCDp

Code Domain Error Power

"Code Domain Error Power" is the difference in power between the measured and the ideal signal. The unit is dB. There are no other units for the y-axis.

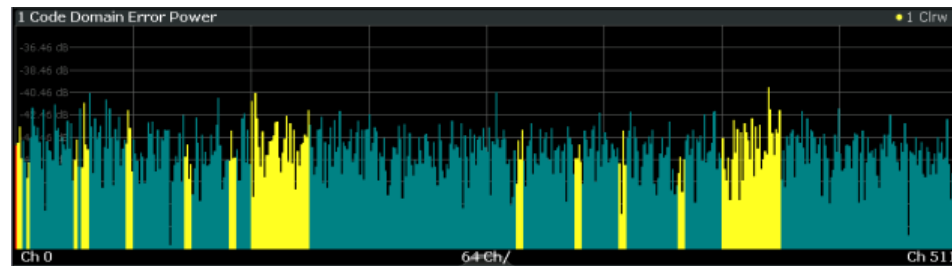

Figure 3-4: Code Domain Error Power Display for 3GPP FDD BTS measurements

Remote command:

LAY:ADD? '1',RIGH, CDEPower, see LAYout:ADD[:WINDow]? on page 235

TRACe<n>[:DATA]? TRACE<1...4>

Composite Constellation

The "Composite Constellation" evaluation analyzes the entire signal for one single slot. If many channels are to be analyzed, the results are superimposed. In that case, the benefit of this evaluation is limited (senseless).

In "Composite Constellation" evaluation the constellation points of the 1536 chips are displayed for the specified slot. This data is determined inside the DSP even before the channel search. Thus, it is not possible to assign constellation points to channels. The constellation points are displayed normalized to the total power.

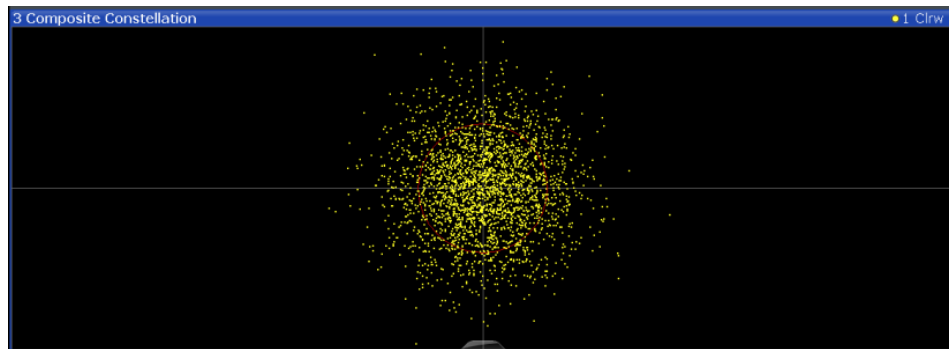

Figure 3-5: Composite Constellation display for 3GPP FDD BTS measurements

Remote command:

LAY:ADD? '1', RIGH, CCONst, see LAYout:ADD[:WINDow]? on page 235
 TRACe<n>[:DATA]? TRACE<1...4>

Composite EVM

The "Composite EVM" evaluation displays the root mean square composite EVM (modulation accuracy) according to the 3GPP specification. The square root is determined of the mean squared errors between the real and imaginary components of the received signal, and an ideal reference signal (EVM referenced to the total signal). The error is averaged over all channels for individual slots. The "Composite EVM" evaluation covers the entire signal during the entire observation time.

$$EVM_{RMS} = \sqrt{\frac{\sum_{n=0}^N |s_n - x_n|^2}{\sum_{n=0}^{N-1} |x_n|^2}} * 100\% \quad | \quad N = 2560$$

where:

EVM_{RMS}	root mean square of the vector error of the composite signal
s_n	complex chip value of received signal
x_n	complex chip value of reference signal
n	index number for mean power calculation of received and reference signal.
N	number of chips at each CPICH slot

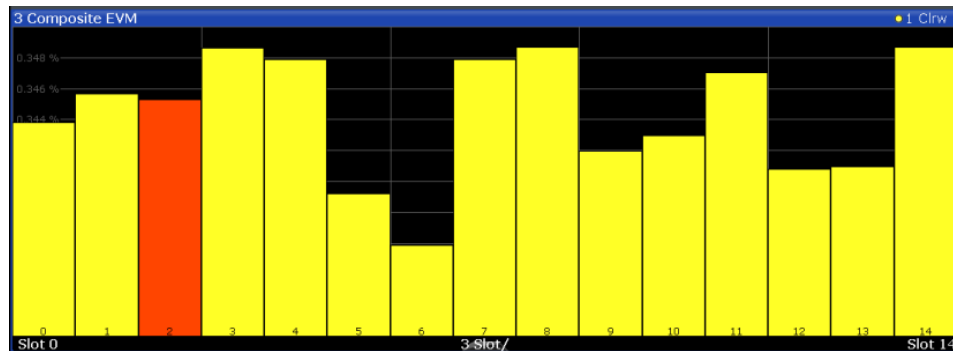

Figure 3-6: Composite EVM display for 3GPP FDD BTS measurements

The measurement result consists of one composite EVM measurement value per slot. In this case, the measurement interval is the slot spacing of the CPICH (timing offset of 0 chips referenced to the beginning of the frame). Only the channels recognized as active are used to generate the ideal reference signal. If an assigned channel is not recognized as active because pilot symbols are missing or incomplete, the difference between the measurement and reference signal and the composite EVM is very high.

Remote command:

```
LAY:ADD? '1',RIGH, CEVM, see LAYout:ADD[:WINDow]? on page 235
TRACe<n>[:DATA]? TRACE<1...4>
```

EVM vs Chip

"EVM vs Chip" activates the Error Vector Magnitude (EVM) versus chip display. The EVM is displayed for all chips of the selected slot.

Note: In UE measurements, if the measurement interval "Halfslot" is selected for evaluation, 30 slots are displayed instead of the usual 15 (see "Measurement Interval" on page 119).

The EVM is calculated by the root of the square difference of received signal and reference signal. The reference signal is estimated from the channel configuration of all active channels. The EVM is related to the square root of the mean power of reference signal and given in percent.

$$EVM_k = \sqrt{\frac{|s_k - x_k|^2}{\frac{1}{N} \sum_{n=0}^{N-1} |x_n|^2}} \cdot 100\% \quad | N = 2560 \quad | k \in [0 \dots (N-1)]$$

where:

EVM_k	vector error of the chip EVM of chip number k
s_k	complex chip value of received signal
x_k	complex chip value of reference signal
k	index number of the evaluated chip

N	number of chips at each CPICH slot
n	index number for mean power calculation of reference signal

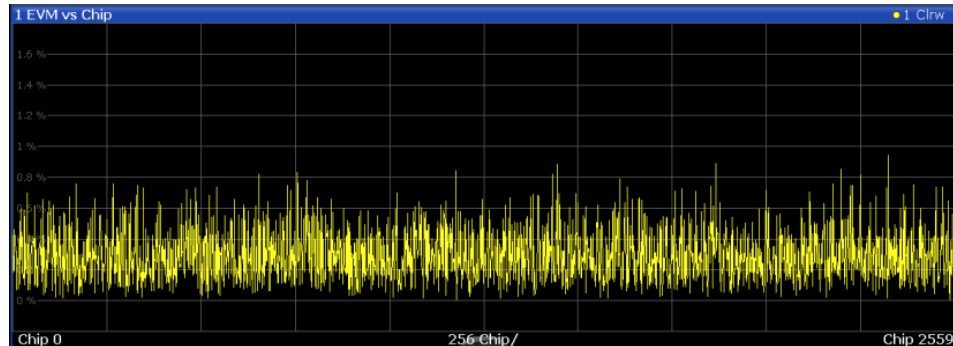

Figure 3-7: EVM vs Chip display for 3GPP FDD BTS measurements

Remote command:

LAY:ADD? '1',RIGH, EVMChip, see [LAYOUT:ADD\[:WINDOW\]?](#) on page 235
[TRACE<n>\[:DATA\]? TRACE<1...4>](#)

Frequency Error vs Slot

For each value to be displayed, the difference between the frequency error of the corresponding slot to the frequency error of the first (zero) slot is calculated (based on CPICH slots). This helps eliminate a static frequency offset of the whole signal to achieve a better display of the actual time-dependant frequency diagram.

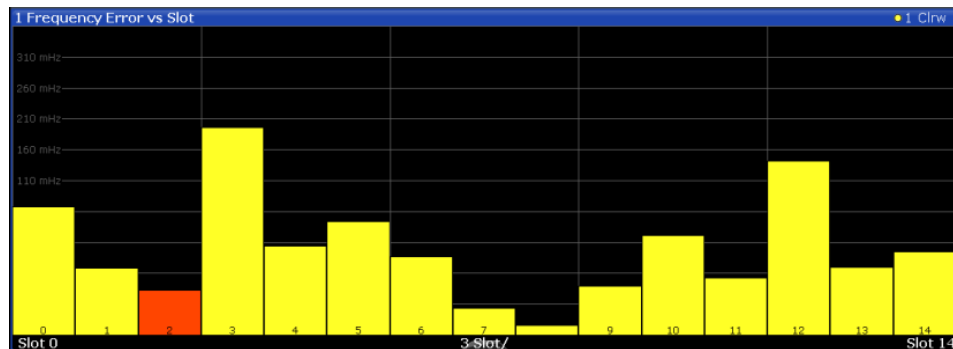

Figure 3-8: Frequency Error vs Slot display for 3GPP FDD BTS measurements

Remote command:

LAY:ADD? '1',RIGH, FESlot, see [LAYOUT:ADD\[:WINDOW\]?](#) on page 235
[TRACE<n>\[:DATA\]? ATRACE](#)

Magnitude Error vs Chip

The Magnitude Error versus chip display shows the magnitude error for all chips of the selected slot.

Note: In UE measurements, if the measurement interval "Halfslot" is selected for evaluation, 30 slots are displayed instead of the usual 15 (see ["Measurement Interval"](#) on page 119).

The magnitude error is calculated as the difference of the magnitude of the received signal to the magnitude of the reference signal. The reference signal is estimated from the channel configuration of all active channels. The magnitude error is related to the square root of the mean power of reference signal and given in percent.

$$MAG_k = \sqrt{\frac{|s_k| - |x_k|}{\frac{1}{N} \sum_{n=0}^{N-1} |x_n|^2}} \cdot 100\% \quad | N = 2560 \quad | k \in [0 \dots (N-1)]$$

Where:

MAG _k	Magnitude error of chip number k
s _k	Complex chip value of received signal
x _k	Complex chip value of reference signal
k	Index number of the evaluated chip
N	Number of chips at each CPICH slot
n	Index number for mean power calculation of reference signal

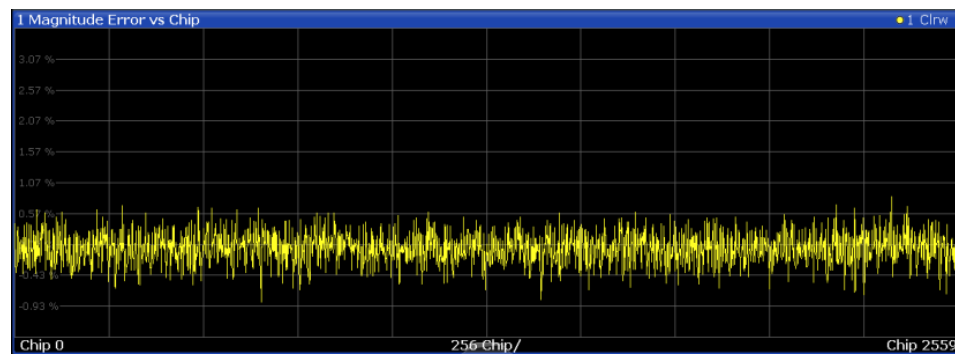

Figure 3-9: Magnitude Error vs Chip display for 3GPP FDD BTS measurements

Remote command:

LAY:ADD? '1',RIGH, MEChip, see LAYout:ADD[:WINDow]? on page 235
 TRACe<n>[:DATA]? TRACE<1...4>

Marker Table

Displays a table with the current marker values for the active markers.

This table is displayed automatically if configured accordingly.

(See "Marker Table Display" on page 126).

Wnd	Type	Ref	Trc	X-Value	Y-Value	Function	Function Result
2	M1		1	2.1725 ms	-6.80 dBm		
2	D2	M1	1	13.859 ms	-0.00 dB		
2	D3	M1	1	4.6259 ms	-0.00 dB		
2	D4	M1	1	9.2331 ms	-0.00 dB		

Tip: To navigate within long marker tables, simply scroll through the entries with your finger on the touchscreen.

Remote command:

LAY:ADD? '1',RIGH, MTAB, see LAYout:ADD[:WINDow]? on page 235

Results:

CALCulate<n>:MARKer<m>:X on page 275

CALCulate<n>:MARKer<m>:Y? on page 276

Peak Code Domain Error

In line with the 3GPP specifications, the error between the measurement signal and the ideal reference signal for a given slot and for all codes is projected onto the various spreading factors. The result consists of the peak code domain error value per slot. The measurement interval is the slot spacing of the CPICH (timing offset of 0 chips referenced to the beginning of the frame). Only the channels recognized as active are used to generate the ideal reference signal for the peak code domain error. If an assigned channel is not recognized as active since pilot symbols are missing or incomplete, the difference between the measurement and reference signal is very high. This display is a bar diagram over slots. The unit is dB. The "Peak Code Domain Error" evaluation covers the entire signal and the entire observation time.

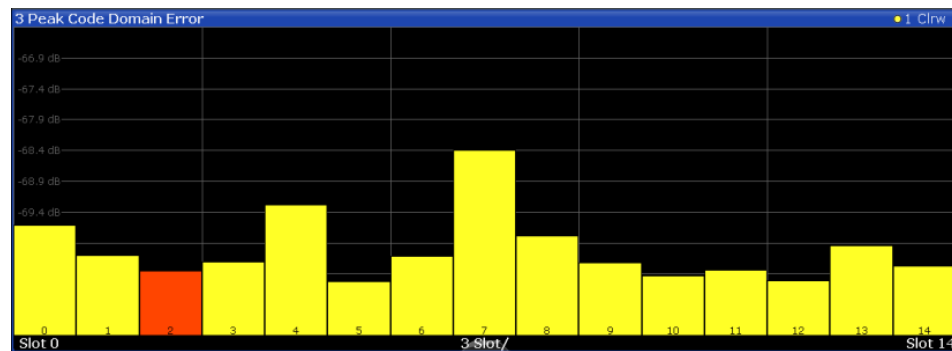

Figure 3-10: Peak Code Domain Error display for 3GPP FDD BTS measurements

Remote command:

LAY:ADD? '1',RIGH, PCDError, see LAYout:ADD[:WINDow]? on page 235

TRACe<n>[:DATA]? TRACE<1...4>

Phase Discontinuity vs Slot

The "Phase Discontinuity vs Slot" is calculated according to 3GPP specifications. The phase calculated for each slot is interpolated to both ends of the slot using the frequency shift of that slot. The difference between the phase interpolated for the beginning of one slot and the end of the preceding slot is displayed as the phase discontinuity of that slot.

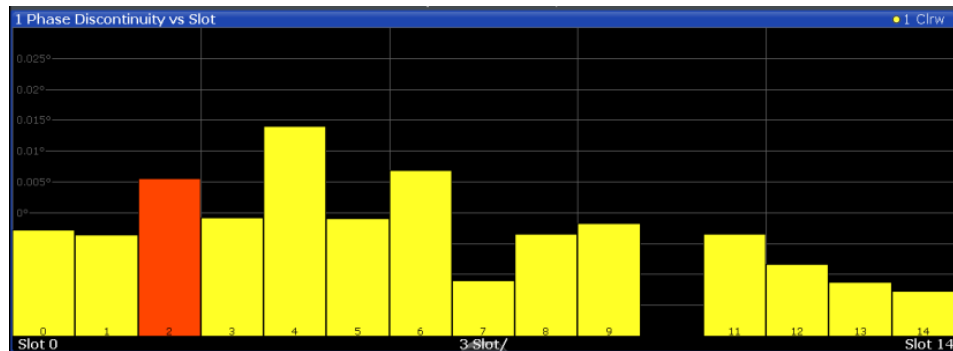

Figure 3-11: Phase Discontinuity vs Slot display for 3GPP FDD BTS measurements

Remote command:

LAY:ADD? '1',RIGH, PDSLot, see LAYout:ADD[:WINDow]? on page 235
 TRACe<n>[:DATA]? TRACE<1...4>

Phase Error vs Chip

"Phase Error vs Chip" activates the phase error versus chip display. The phase error is displayed for all chips of the selected slot.

Note: In UE measurements, if the measurement interval "Halfslot" is selected for evaluation, 30 slots are displayed instead of the usual 15 (see "Measurement Interval" on page 119).

The phase error is calculated by the difference of the phase of received signal and phase of reference signal. The reference signal is estimated from the channel configuration of all active channels. The phase error is given in degrees in a range of +180° to -180°.

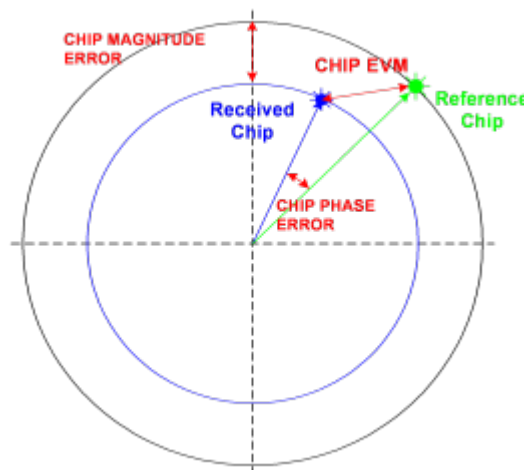
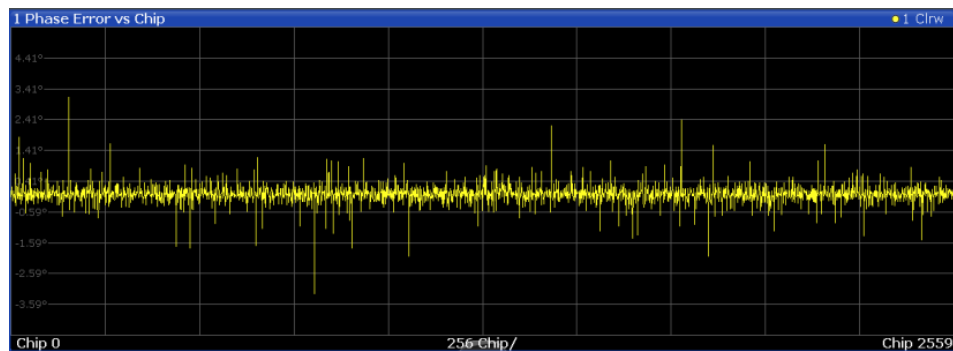

Figure 3-12: Calculating the magnitude, phase and vector error per chip

$$\Phi_k = \varphi(s_k) - \varphi(x_k) \quad | \quad N = 2560 \quad | \quad k \in [0 \dots (N-1)]$$

Where:

PHI_k	Phase error of chip number k
s_k	Complex chip value of received signal
x_k	Complex chip value of reference signal
k	Index number of the evaluated chip
N	Number of chips at each CPICH slot
$\varphi(x)$	Phase calculation of a complex value



Remote command:

LAY:ADD? '1',RIGH, PEChip, see [LAYout:ADD\[:WINDow\]?](#) on page 235
[TRACe<n>\[:DATA\]? TRACE<1...4>](#)

Power vs Slot

The "Power vs Slot" evaluation displays the power of the selected channel for each slot. The power is displayed either absolute or relative to the total power of the signal or to the CPICH channel.

Note: In UE measurements, this evaluation is only available if the analysis mode "Frame" is selected (see ["Capture Mode"](#) on page 88).

If the measurement interval "Halfslot" is selected for evaluation, 30 slots are displayed instead of the usual 15 (see ["Measurement Interval"](#) on page 119).

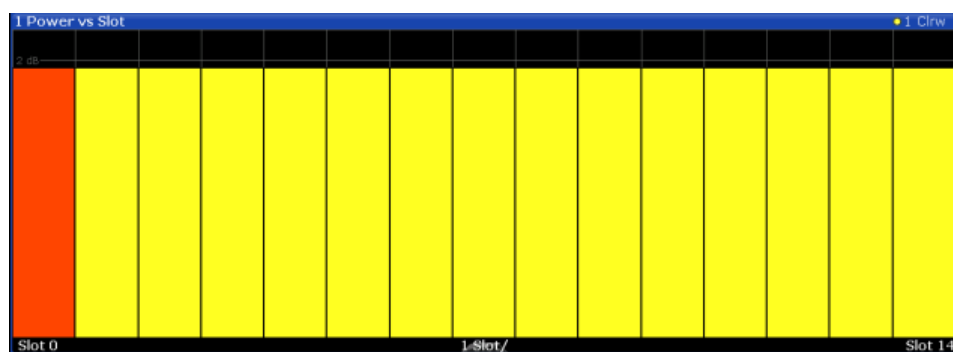

Figure 3-13: Power vs Slot Display for 3GPP FDD BTS measurements

If a timing offset of the selected channel in relation to the CPICH channel occurs, the power is calculated and displayed per channel slot (as opposed to the "Code Domain Power" evaluation). However, for reference purposes, the grid in the "Power vs Slot" diagram indicates the CPICH slots. The first CPICH slot is always slot 0, the grid and labels of the grid lines do not change. Thus, the channel slots can be shifted in the diagram grid. The channel slot numbers are indicated within the power bars. The selected slot is highlighted in the diagram.

Remote command:

LAY:ADD? '1',RIGH, PSLot, see LAYout:ADD[:WINDow]? on page 235
 TRACe<n>[:DATA]? TPVSlot

Power vs Symbol

The Power vs. Symbol evaluation shows the power over the symbol number for the selected channel and the selected slot. The power is not averaged here. The trace is drawn using a histogram line algorithm, i.e. only vertical and horizontal lines, no diagonal, linear Interpolation (polygon interpolation). Surfaces are NOT filled.

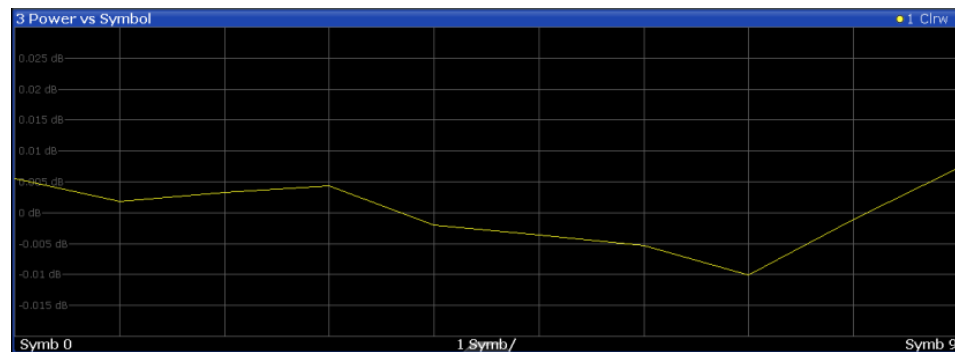

Figure 3-14: Power vs Symbol display for 3GPP FDD BTS measurements

Remote command:

LAY:ADD? '1',RIGH, PSYMBOL, see LAYout:ADD[:WINDow]? on page 235
 TRACe<n>[:DATA]? TRACE<1...4>

Result Summary

The "Result Summary" evaluation displays a list of measurement results on the screen. For details see Chapter 3.1.1, "Code domain parameters", on page 17.

2 Result Summary					
General Results (Frame 0, CPICH Slot 2)					
Total Power	-10.79 dBm	Carrier Freq Error	-1.46 kHz	Chip Rate Error	1.46 ppm
Trigger To Frame	4.176281 ms	IQ Offset	0.08	IQ Imbalance	0.05 %
Avg Power Inact Chan	-100.19 dB	Composite EVM	0.34 %	Pk CDE(15 Ksps)	-70.17 dB
Rho	0.999988	No of Active Channels	44	Avg.RCDE(64QAM)	---
Channel Results (Ch 19.128)					
Symbol Rate	30 ksym/s	Timing Offset	6400 Chips	No of Pilot Bits	8
Channel Slot No	0	RCDE	-45.43 dB	Modulation Type	QPSK
Channel Power Abs	-35.82 dBm	Symbol EVM	1.23 % PK		
Channel Power Rel	-13.99 dB	Symbol EVM	0.66 % rms		

Figure 3-15: Result Summary display for 3GPP FDD BTS measurements

Remote command:

LAY:ADD? '1',RIGH, RSUMmary, see LAYout:ADD[:WINDow]? on page 235
 TRACe<n>[:DATA]? TRACE<1...4>
 TRACe[:DATA]? TRACE<1...4>

Symbol Constellation

The "Symbol Constellation" evaluation shows all modulated signals of the selected channel and the selected slot. QPSK constellation points are located on the diagonals (not x and y-axis) of the constellation diagram. BPSK constellation points are always on the x-axis.

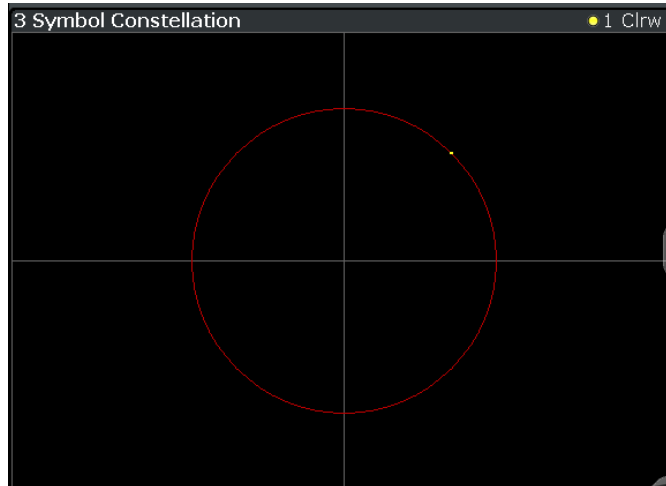

Figure 3-16: Symbol Constellation display for 3GPP FDD BTS measurements

Remote command:

LAY:ADD? '1',RIGH, SCONst, see LAYout:ADD[:WINDow]? on page 235
 TRACe<n>[:DATA]? TRACE<1...4>

Symbol EVM

The "Symbol EVM" evaluation shows the error between the measured signal and the ideal reference signal in percent for the selected channel and the selected slot. A trace over all symbols of a slot is drawn. The number of symbols is in the range from 12 (min) to 384 (max). It depends on the symbol rate of the channel.

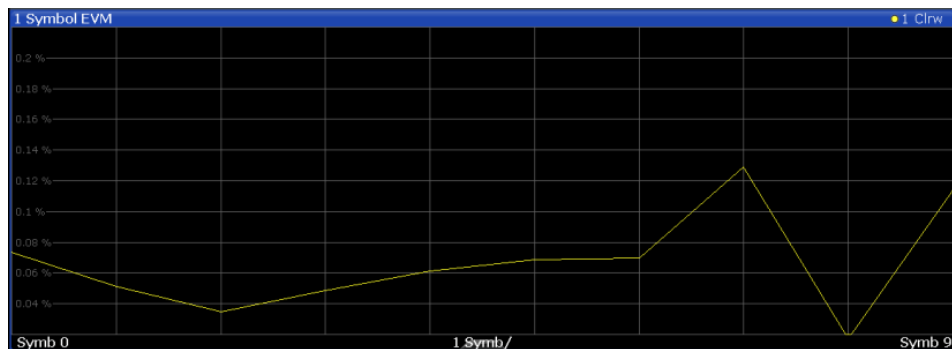

Figure 3-17: Symbol EVM display for 3GPP FDD BTS measurements

Remote command:

LAY:ADD? '1',RIGH, SEVM, see LAYout:ADD[:WINDow]? on page 235
 TRACe<n>[:DATA]? TRACE<1...4>

Symbol Magnitude Error

The "Symbol Magnitude Error" is calculated analogous to symbol EVM. The result is one symbol magnitude error value for each symbol of the slot of a special channel. Positive values of symbol magnitude error indicate a symbol magnitude that is larger than the expected ideal value. Negative symbol magnitude errors indicate a symbol magnitude that is less than the expected ideal value. The symbol magnitude error is the difference between the magnitude of the received symbol and that of the reference symbol, related to the magnitude of the reference symbol.

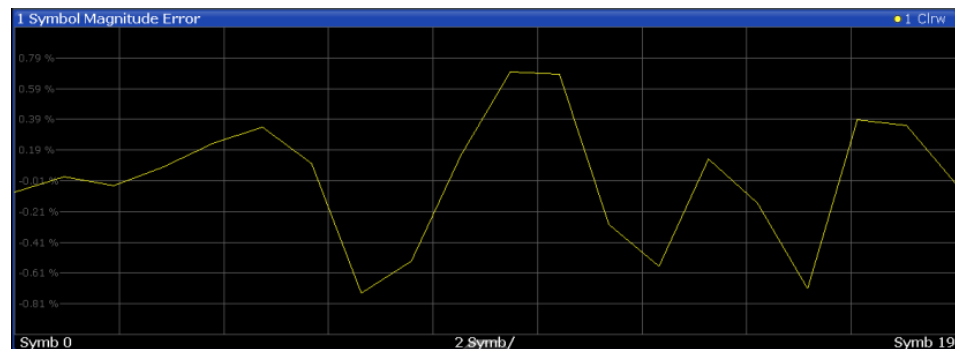

Figure 3-18: Symbol Magnitude Error display for 3GPP FDD BTS measurements

Remote command:

LAY:ADD? '1',RIGH, SMERror, see LAYout:ADD[:WINDow]? on page 235
 TRACe<n>[:DATA]? TRACE<1...4>

Symbol Phase Error

The "Symbol Phase Error" is calculated analogous to symbol EVM. The result is one symbol phase error value for each symbol of the slot of a special channel. Positive values of symbol phase error indicate a symbol phase that is larger than the expected ideal value. Negative symbol phase errors indicate a symbol phase that is less than the expected ideal value.

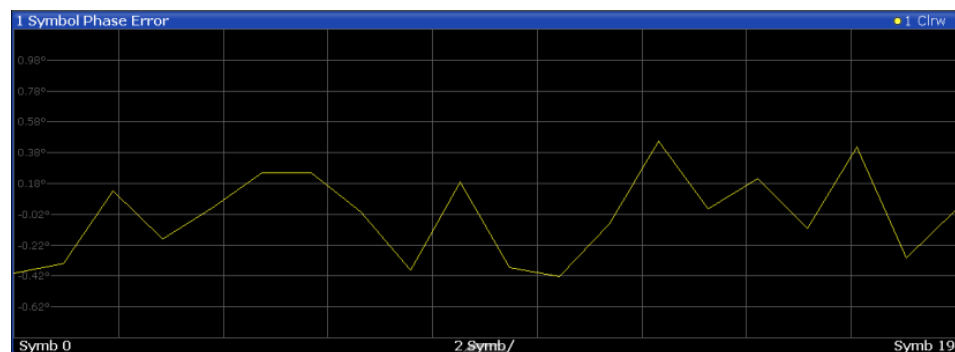

Figure 3-19: Symbol Phase Error display for 3GPP FDD BTS measurements

Remote command:

LAY:ADD? '1',RIGH, SPERror, see LAYout:ADD[:WINDow]? on page 235
 TRACe<n>[:DATA]? TRACE<1...4>

3.1.3 CDA measurements in MSRA operating mode

The 3GPP FDD BTS application can also be used to analyze data in MSRA operating mode.

In MSRA operating mode, only the MSRA primary actually captures data; the MSRA applications receive an extract of the captured data for analysis, referred to as the **application data**. The application data range is indicated in the MSRA primary by vertical blue lines.

However, the individual result displays of the application need not analyze the complete data range. The data range that is actually analyzed by the individual result display is referred to as the **analysis interval**.

In the 3GPP FDD BTS application, the analysis interval is automatically determined. It depends on the selected channel/ slot/ frame to analyze, which is defined for the evaluation range, and on the result display. The currently used analysis interval (in seconds, related to capture buffer start) is indicated in the window header for each result display.

For details on the MSRA operating mode, see the FSW MSRA User Manual.

3.2 Time alignment error measurements

Access: [MEAS] > "Time Alignment Error"

"Time Alignment Error" measurements are a special type of "Code Domain Analysis" used to determine the time offset between signals on different antennas in a base station and different base stations. This measurement is required by the standard for Tx diversity and MIMO signals. It can be performed for the two transmitter branches of a BTS as well as for the transmit signals of multiple base stations on different transmit frequencies.

They are only available in 3GPP FDD BTS measurements.

The numeric results are displayed in a table.



Synchronization errors

A synchronization check is performed for both antennas which must have the result "Sync OK" to ensure a proper TAE result. Synchronization problems are indicated by the messages "No antenna 1 sync", "No antenna 2 sync" and "No sync".

For more information, see [Chapter 4.8, "Time alignment error measurements"](#), on page 54.

Evaluation Methods

For "Time Alignment Error" measurements, the following evaluation methods are available:

Time Alignment Error

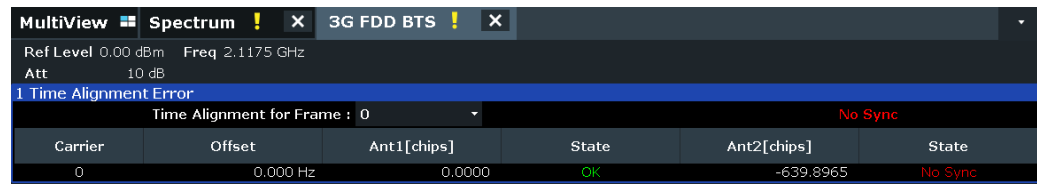

Figure 3-20: Time Alignment Error display for 1 base station

Provides the following time alignment information for the selected frame:

"Carrier"	Carrier number
"Offset"	Frequency offset from the nominal frequency for each carrier
"Ant1 [chips]"/ "Ant2 [chips]"	Time delay (in chips) for each antenna, relative to the specified reference carrier.
"State"	Synchronization state for each antenna ("OK" / "No Sync"). The overall status indicated above the table is "SYNC OK" only if the signals for all of the antennas for all of the base stations defined in the table are "SYNC OK".

Remote command:

CONF:WCDP:MEAS TAER, see [CONFigure:WCDPower\[:BTS\]:MEASurement](#) on page 159

Selecting the frame:

[\[SENSe:\]CDPower:FRAME\[:VALue\]](#) on page 223

Retrieving results:

CALC:MARK:FUNC:TAER:RES? TAER, see [CALCulate<n>:MARKer<m>:FUNCTION:TAERror:RESult](#) on page 247

3.3 RF measurements

In addition to the "Code Domain Analysis" measurements, the 3GPP FDD applications also provide some RF measurements as defined in the 3GPP FDD standard. RF measurements are identical to the corresponding measurements in the base unit, but configured according to the requirements of the 3GPP FDD standard.

For details on these measurements see the FSW User Manual.



MSRA operating mode

RF measurements are not available in MSRA operating mode.

For details on the MSRA operating mode, see the FSW MSRA User Manual.

3.3.1 RF measurement types and results

Access: [MEAS] > Select Meas

The 3GPP FDD applications provide the following RF measurements:

Channel Power ACLR.....	36
Occupied Bandwidth.....	36
Power.....	36
RF Combi.....	37
Spectrum Emission Mask.....	38
CCDF.....	39

Channel Power ACLR

Access: [MEAS] > "Channel Power ACLR"

"Channel Power ACLR" performs an adjacent channel power measurement in the default setting according to 3GPP specifications (adjacent channel leakage ratio).

The FSW measures the channel power and the relative power of the adjacent channels and of the alternate channels. The results are displayed below the diagram.

Remote command:

CONF:WCDP:MEAS ACLR, see [CONFIGure:WCDPower\[:BTS\]:MEASurement](#) on page 159

Querying results:

CALC:MARK:FUNC:POW:RES? ACP, see [CALCulate<n>:MARKer<m>:FUNction:POWer<sb>:RESult?](#) on page 270

CALC:MARK:FUNC:POW:RES? ACP, see [CALCulate<n>:MARKer<m>:FUNction:POWer<sb>:RESult?](#) on page 270

Occupied Bandwidth

Access: [MEAS] > "OBW"

The "Occupied Bandwidth" measurement determines the bandwidth that the signal occupies.

The occupied bandwidth is defined as the bandwidth in which – in default settings - 99 % of the total signal power is to be found. The percentage of the signal power to be included in the bandwidth measurement can be changed.

The occupied bandwidth (Occ BW) and the frequency markers are displayed in the marker table.

Remote command:

CONF:WCDP:MEAS OBAN, see [CONFIGure:WCDPower\[:BTS\]:MEASurement](#) on page 159

Querying results:

CALC:MARK:FUNC:POW:RES? OBW, see [CALCulate<n>:MARKer<m>:FUNction:POWer<sb>:RESult?](#) on page 270

CALC:MARK:FUNC:POW:RES? ACP, see [CALCulate<n>:MARKer<m>:FUNction:POWer<sb>:RESult?](#) on page 270

Power

Access: [MEAS] > "Power"

The Output Power measurement determines the 3GPP FDD signal channel power. The FSW measures the unweighted RF signal power in a bandwidth of:

$$f_{RW} = 5 \text{ MHz} \geq (1 + \alpha) \cdot 3.84 \text{ MHz} \quad | \quad \alpha = 0.22$$

The power is measured in zero span mode (time domain) using a digital channel filter of 5 MHz in bandwidth. According to the 3GPP standard, the measurement bandwidth (5 MHz) is slightly larger than the minimum required bandwidth of 4.7 MHz. The bandwidth is displayed numerically below the screen.

Remote command:

CONF:WCDP:MEAS POW, see [CONFigure:WCDPower\[:BTS\]:MEASurement](#) on page 159

Querying results: CALC:MARK:FUNC:POW:RES? CPOW, see [CALCulate<n>:MARKer<m>:FUNCtion:POWer<sb>:RESult?](#) on page 270

CALC:MARK:FUNC:POW:RES? ACP, see [CALCulate<n>:MARKer<m>:FUNCtion:POWer<sb>:RESult?](#) on page 270

RF Combi

Access: [MEAS] > "RF Combi"

This measurement combines the following measurements:

- "Channel Power ACLR" on page 36
- "Occupied Bandwidth" on page 36
- "Spectrum Emission Mask" on page 38

The ACLR and OBW are measured on trace 1, from which the SEM trace 2 is derived via integration.

The advantage of the RF COMBI measurement is that all RF results are measured with a single measurement process. This measurement is faster than the three individual measurements.



Figure 3-21: RF Combi measurement results

Remote command:

CONF:WCDP:BTS:MEAS RFC, see [CONFigure:WCDPower\[:BTS\]:MEASurement](#) on page 159

Querying results:

CALC:MARK:FUNC:POW:RES? ACP [CALCulate<n>:MARKer<m>:FUNCTION:POWER<sb>:RESult?](#) on page 270

CALC:MARK:FUNC:POW:RES? OBW

CALC:MARK:FUNC:POW:RES? CPOW

CALC:MARK:FUNC:POW:RES? ACP, see [CALCulate<n>:MARKer<m>:FUNCTION:POWER<sb>:RESult?](#) on page 270

CALC:MARK:FUNC:POW:RES? OBW

CALC:MARK:FUNC:POW:RES? CPOW

[CALCulate<n>:LIMIT:FAIL?](#) on page 269

Spectrum Emission Mask

Access: [MEAS] > "Spectrum Emission Mask"

The "Spectrum Emission Mask" measurement determines the power of the 3GPP FDD signal in defined offsets from the carrier and compares the power values with a spectral mask specified by 3GPP.

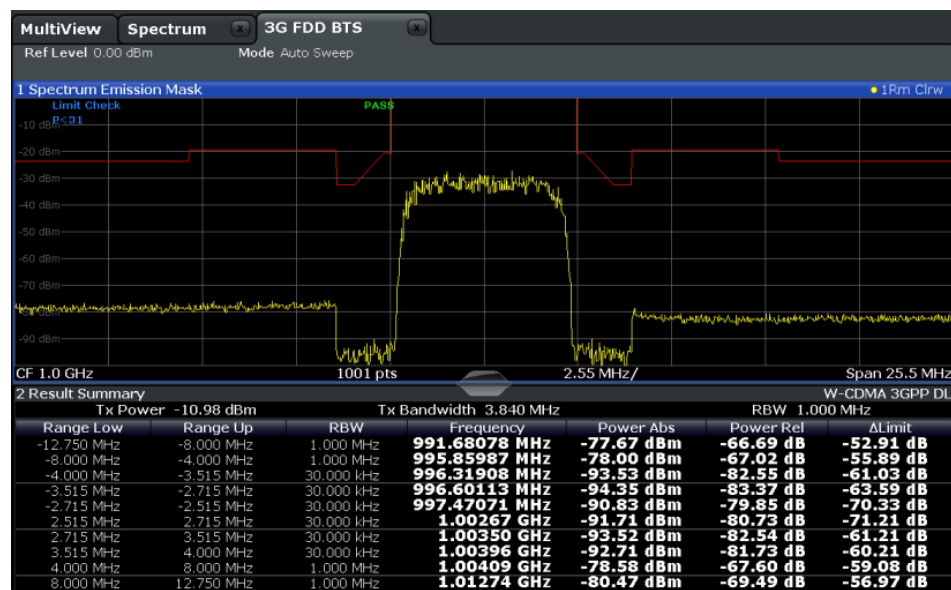

Figure 3-22: SEM measurement results for 3GPP FDD BTS measurements

Remote command:

CONF:WCDP:MEAS ESP, see [CONFigure:WCDPower\[:BTS\]:MEASurement](#) on page 159

Querying results:

CALC:MARK:FUNC:POW:RES? CPOW, see [CALCulate<n>:MARKer<m>:FUNCTION:POWER<sb>:RESult?](#) on page 270

CALC:MARK:FUNC:POW:RES? ACP, see [CALCulate<n>:MARKer<m>:FUNCTION:POWER<sb>:RESult?](#) on page 270

[CALCulate<n>:LIMIT:FAIL?](#) on page 269

CCDF**Access:** [MEAS] > "CCDF"

The "CCDF" measurement determines the distribution of the signal amplitudes (complementary cumulative distribution function). The "CCDF" and the Crest factor are displayed. For the purposes of this measurement, a signal section of user-definable length is recorded continuously in the zero span, and the distribution of the signal amplitudes is evaluated.

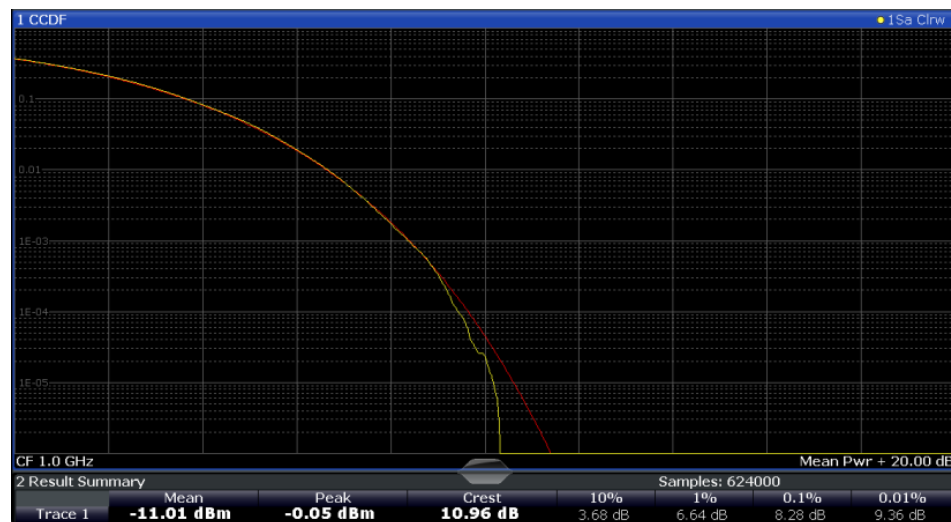

Figure 3-23: CCDF measurement results for 3GPP FDD BTS measurements

Remote command:

CONF:WCDP:MEAS CCDF, see [CONFigure:WCDPower\[:BTS\]:MEASurement](#) on page 159

Querying results:

[CALCulate<n>:MARKer<m>:Y?](#) on page 276

[CALC:MARK:FUNC:POW:RES? ACP](#), see [CALCulate<n>:MARKer<m>:FUNCtion:POWer<sb>:RESult?](#) on page 270

[CALC:MARK:FUNC:POW:RES? ACP](#), see [CALCulate<n>:MARKer<m>:FUNCtion:POWer<sb>:RESult?](#) on page 270

[CALCulate<n>:STATistics:RESult<res>?](#) on page 272

3.3.2 Evaluation methods for RF measurements



Access: "Overview" > "Display Config"

The evaluation methods for RF measurements are identical to those in the Spectrum application.

Diagram	40
Result Summary	40
Marker Table	40
Marker Peak List	41

Diagram

Displays a basic level vs. frequency or level vs. time diagram of the measured data to evaluate the results graphically. This is the default evaluation method. Which data is displayed in the diagram depends on the "Trace" settings. Scaling for the y-axis can be configured.

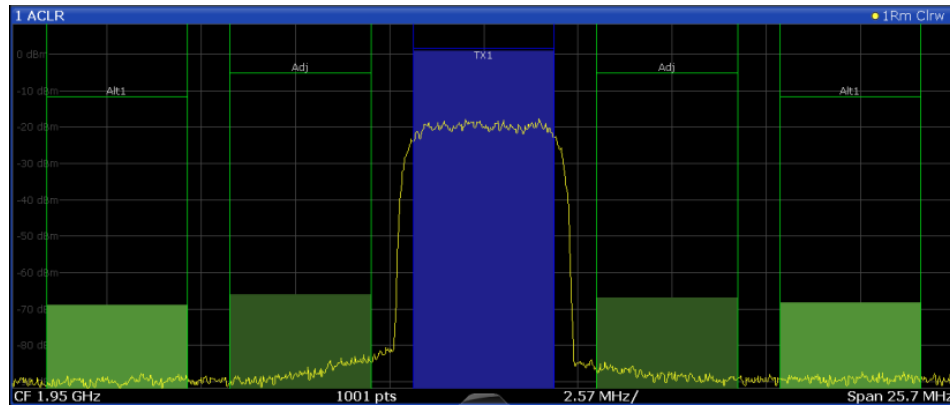

Remote command:

LAY:ADD? '1',RIGH, DIAG, see [LAYout:ADD\[:WINDow\]?](#) on page 235

Results:

Result Summary

Result summaries provide the results of specific measurement functions in a table for numerical evaluation. The contents of the result summary vary depending on the selected measurement function. See the description of the individual measurement functions for details.

2 Result Summary				
Channel	Bandwidth	Offset	Power	
TX1 (Ref)	1.229 MHz		-0.86 dBm	
Tx Total			-0.86 dBm	
Channel	Bandwidth	Offset	Lower	Upper
Adj	30.000 kHz	750.000 kHz	-79.59 dB	-80.34 dB
Alt1	30.000 kHz	1.980 MHz	-85.04 dB	-83.85 dB

Tip: To navigate within long marker tables, simply scroll through the entries with your finger on the touchscreen.

Remote command:

LAY:ADD? '1',RIGH, RSUM, see [LAYout:ADD\[:WINDow\]?](#) on page 235

Marker Table

Displays a table with the current marker values for the active markers.

This table is displayed automatically if configured accordingly.

(See "[Marker Table Display](#)" on page 126).

1 Marker Table							
Wnd	Type	Ref	Trc	X-Value	Y-Value	Function	Function Result
2	M1		1	2.1725 ms	-6.80 dBm		
2	D2	M1	1	13.859 ms	-0.00 dB		
2	D3	M1	1	4.6259 ms	-0.00 dB		
2	D4	M1	1	9.2331 ms	-0.00 dB		

Tip: To navigate within long marker tables, simply scroll through the entries with your finger on the touchscreen.

Remote command:

LAY:ADD? '1',RIGH, MTAB, see LAYout:ADD[:WINDow]? on page 235

Results:

[CALCulate<n>:MARKer<m>:X](#) on page 275

[CALCulate<n>:MARKer<m>:Y?](#) on page 276

Marker Peak List

The marker peak list determines the frequencies and levels of peaks in the spectrum or time domain. How many peaks are displayed can be defined, as well as the sort order. In addition, the detected peaks can be indicated in the diagram. The peak list can also be exported to a file for analysis in an external application.

3 Marker Peak List			
Wnd	No	X-Value	Y-Value
2	1	1.086245 ms	-75.810 dBm
2	2	2.172490 ms	-6.797 dBm
2	3	3.258736 ms	-76.448 dBm
2	4	4.831918 ms	-76.676 dBm
2	5	6.255274 ms	-76.482 dBm
2	6	6.798397 ms	-6.800 dBm
2	7	9.233084 ms	-76.519 dBm
2	8	10.075861 ms	-76.172 dBm
2	9	11.405574 ms	-6.801 dBm

Tip: To navigate within long marker peak lists, simply scroll through the entries with your finger on the touchscreen.

Remote command:

LAY:ADD? '1',RIGH, PEAK, see LAYout:ADD[:WINDow]? on page 235

Results:

[CALCulate<n>:MARKer<m>:X](#) on page 275

[CALCulate<n>:MARKer<m>:Y?](#) on page 276

4 Measurement basics

Some background knowledge on basic terms and principles used in 3GPP FDD tests and measurements is provided here for a better understanding of the required configuration settings.

Basic principle

The basic principle of 3GPP FDD (frequency division duplex) is that the communication between a base station and several mobile stations is performed in the same frequency band and in the same time slots. The separation of the data for the different mobile stations is achieved by using CDMA (Code Division Multiple Access). In this technique, channels are distinguished by using different orthogonal codes.

Scrambling codes

Each base station uses a unique scrambling code. The mobile station can only demodulate the base station signal if it knows which scrambling code was used by the base station.

Thus, in order to demodulate the data in the 3GPP FDD applications, you must either specify the scrambling code explicitly, or the application can perform an automatic search to detect the scrambling code itself.

Channels, codes and symbol rate

In signals according to the 3GPP FDD standard, the data is transmitted in channels. These channels are based on orthogonal codes and can have different data rates. The data rate depends on the used modulation type and the spreading factor of the channel.

Spreading factors

Spreading factors determine whether the transmitted data is sent in short or long sequences. The spreading factor is re-assigned dynamically in certain time intervals according to the current demand of users and data to be transmitted. The higher the spreading factor, the lower the data rate; the lower the spreading factor, the higher the data rate.

The smallest available spreading factor is 4, the largest is 512. So we can say that the code domain consists of 512 basic codes. A channel with a lower spreading factor consists of several combined codes. That means a channel can be described by its number and its spreading factor.

The following table shows the relationship between the code class, the spreading factor, the number of codes per channel, and the symbol rate.

Table 4-1: Relationship between code class, spreading factor, codes per channel and symbol rate for 3GPP FDD signals

Code class	Spreading factor	No. codes / channel	Symbol rate
2	4	128	960 ksps
3	8	64	480 ksps
4	16	32	240 ksps
5	32	16	120 ksps
6	64	8	60 ksps
7	128	4	30 ksps
8	256	2	15 ksps
9	512	1	7.5 ksps



In the measurement settings and results, the spreading factor is often represented by the corresponding symbol rate (in kilo symbols per second, ksps). The power of a channel is always measured in relation to its symbol rate (or spreading factor).

In the 3GPP FDD applications, the channel number consists of the used spreading factor and the channel's sequential number in the code domain, assuming the code domain is divided into equal divisions:

<sequence number>.<spreading factor>

Example:

For a channel number of 5.32, for example, imagine a code domain of 512 codes with a scale of 16 codes per division. Each division represents a possible channel with spreading factor 32. Since channel numbering starts at 0, channel number 5 is the sixth division on the scale.

Selected codes and channels

In the result displays that refer to channels, the currently selected channel is highlighted in the diagram. You select a channel by entering a channel number and spreading factor in the "Evaluation Range" settings. In the example above, if you select the channel number 5.32, the sixth division on the scale with 16 codes per division is highlighted.

For the display in the 3GPP FDD applications, the scale for code-based diagrams contains 512 divisions, one for each code. The selected channel in the example (5.32) would thus correspond to codes 80-96. (The division starts at $5 \cdot 16 = 80$ and is 16 codes wide.)

If no spreading factor is given for the channel number, the default factor 512 is assumed. Channel number 5 would thus refer to the sixth division on the scale, which is the sixth code in the code domain. If the code belongs to a detected channel, the entire channel is highlighted.

If the selected channel is not active, only the first code belonging to the corresponding division is highlighted. In the example, for the inactive channel number 5.32, the first code in the sixth division on the scale with 16 codes per division is highlighted. That corresponds to code number 80 with the scale based on 512 divisions.

Special channels - PCCPCH, SCH, CPICH, DPCH

In order to control the data transmission between the sender and the receiver, specific symbol must be included in the transmitted data, for example the scrambling code of the sender or the used spreading factor, as well as synchronization data for different channels. This data is included in special data channels defined by the 3GPP standard which use fixed codes in the code domain. Thus, they can be detected easily by the receiver.

The **Primary Common Control Physical Channel** (PCCPCH) must always be contained in the signal. As the name implies, it is responsible for common control of the channels during transmission.

The **Synchronization Channel** (SCH) is a time reference and responsible for synchronizing the individual channels.

Another important channel is the **Common Pilot Channel** (CPICH), which continuously transmits the sender's scrambling code. This channel is used to identify the sender, but also as a reference in 3GPP FDD signal measurements.

The user data is contained in the **Dedicated Physical Channel** (DPCH).

More details on channel types are provided in [Chapter 4.2, "BTS channel types"](#), on page 45.

Chips, frames and slots

The user data is spread across the available bandwidth using the spreading factor before transmission. The spread bits are referred to as "chips".

A time span of 10 ms is also known as a "frame". A frame is a basic time unit in the transmission process. Each frame is divided into 15 time "slots". Various channel parameters are put in relation to frames or the individual slots in the 3GPP standard, as well as some measurement results for 3GPP FDD signals. A slot contains 2560 chips.

Channel slots versus CPICH slots

The time slots of the individual channels may not be absolutely synchronous. A time offset may occur, so that the slots in a data channel are slightly shifted in relation to the CPICH slots, for example. In the 3GPP FDD BTS application, the CPICH slot number is provided as a reference with the measurement settings in the channel bar. In the "Result Summary", the actual slot number of the evaluated channel is indicated as the "Channel Slot No".

Pilot symbols

Some slots contain a fixed sequence of symbols, referred to as "pilot symbols". These pilot symbols allow the receiver to identify a particular channel, if the unique pilot symbols can be detected in the input signal.

Power control

While the spreading factors are adjusted for each frame, i.e. every 10 ms, the power levels for transmission must be adapted to the current requirements (such as interference) much more dynamically. Thus, power control bits are transmitted in each slot, allowing for much higher change rates. As the CPICH channel continuously transmits the same data, the power level need not be adapted. Thus, the power control bits can lead to a timing offset between the CPICH slots and other channel slots.

4.1 Channel detection

The 3GPP FDD applications provide two basic methods of detecting active channels:

- **Automatic search using pilot sequences**

The application performs an automatic search for active (DPCH) channels throughout the entire code domain. The search is based on the presence of known symbol sequences (pilot symbols) in the despread symbols of a channel. A data channel is considered to be active if the pilot symbols as specified by the 3GPP FDD standard are found at the end of each slot. In this mode, channels without or with incomplete pilot symbols are therefore not recognized as being active.

An exception to this rule is seen in the special channels PICH and SCCPCH, which can be recognized as active in the automatic search mode although they do not contain pilot symbols. Optionally, all QPSK-modulated channels can also be recognized without pilot symbols (see "[HSDPA/UPA](#)" on page 63).

In addition, the channel must exceed a minimum power in order to be considered active (see "[Inactive Channel Threshold \(BTS measurements only\)](#)" on page 92).

In UE measurements, a channel is considered to be active if a minimum signal/noise ratio is maintained within the channel.

- **Comparison with predefined channel tables**

The input signal is compared to a predefined channel table. All channels that are included in the predefined channel table are considered to be active.

4.2 BTS channel types

The 3GPP FDD standard defines various BTS channel types. Some channels are mandatory and must be contained in the signal, as they have control or synchronization functions. Thus, these channels always occupy a specific channel number and use a specific symbol rate by which they can be identified.

Control and synchronization channels

The 3GPP FDD BTS application expects the following control and synchronization channels for the "Code Domain Power" measurements:

Table 4-2: Common 3GPP FDD BTS control channels and their usage

Channel type	Description
PSCH	Primary Synchronization Channel The Primary Synchronization Channel is used to synchronize the signal in the case of SCH synchronization. It is a non-orthogonal channel. Only the power of this channel is determined.
SSCH	Secondary Synchronization Channel The Secondary Synchronization Channel is a non-orthogonal channel. Only the power of this channel is determined.
PCCPCH	Primary Common Control Physical Channel The Primary Common Control Physical Channel is also used to synchronize the signal in the case of SCH synchronization. It is expected at code class 8 and code number 1.
SCCPCH	Secondary Common Control Physical Channel The Secondary Common Control Physical Channel is a QPSK-modulated channel without any pilot symbols. In the 3GPP test models, this channel can be found in code class 8 and code number 3. However, the code class and code number need not be fixed and can vary. For this reason, the following rules are used to indicate the SCCPCH. <ul style="list-style-type: none"> • Only one QPSK-modulated channel without pilot symbols is detected and displayed as the SCCPCH. Any further QPSK-modulated channels without pilot symbols are not detected as active channels. • If the signal contains more than one channel without pilot symbols, the channel that is received in the highest code class and with the lowest code number is displayed as the SCCPCH. It is expected that only one channel of this type is included in the received signal. According to this assumption, this channel is probably the SCCPCH. • If the application is configured to recognize all QPSK-modulated channels without pilot symbols (see "HSDPA/UPA" on page 63), and one of these channels is received at code class 8 and code number 3, it is displayed as the SCCPCH.
CPICH	Common Pilot Channel The Common Pilot Channel is used to synchronize the signal in the case of CPICH synchronization. It is expected at code class 8 and code number 0. If it is not contained in the signal configuration, the firmware application must be configured to synchronize to the SCH channel (see " Synchronization Type " on page 90).

Other channels are optional and contain the user data to be transmitted. A data channel is any channel that does not have a predefined channel number and symbol rate. The following channel types can be detected by the 3GPP FDD BTS application.

Table 4-3: Common 3GPP FDD BTS data channels and their usage

Channel type	Description
PICH	<p>Paging Indication Channel</p> <p>The Paging Indication Channel is expected at code class 8 and code number 16.</p> <p>The lower part of the table indicates the data channels contained in the signal. A data channel is any channel that does not have a predefined channel number and symbol rate. There are different types of data channels, which are indicated in the column "Chan Type".</p>
DPCH	<p>Dedicated Physical Channel of a standard frame</p> <p>The Dedicated Physical Channel is a data channel that contains pilot symbols. The displayed channel type is DPCH.</p>
CPRSD	<p>Dedicated Physical Channel (DPCH) in compressed mode</p> <p>Compressed mode channels usually do not transmit valid symbols in all slots. There are different lengths of the transmitting gap. One to fourteen slots can be switched off in each frame. In some cases outside the gap the symbol rate is increased by 2 to ensure a constant average symbol rate of this channel. In any case all of the transmitted slots contain a pilot sequence defined in the 3GPP specification. There are different types of compressed mode channels.</p> <p>To evaluate compressed mode channels, the associated measurement mode needs to be activated (see "Compressed Mode" on page 64).</p>
CPR-TPC	DPCH in compressed mode where TPC symbols are sent in the first slot of the transmitting gap
CPR-SF/2	DPCH in compressed mode using half spreading factor (SF/2) to increase the symbol rate of the active slots by two
CPR-SF/2-TPC	DPCH in compressed mode using half spreading factor (SF/2) to increase the symbol rate of the active slots by two, where TPC symbols are sent in the first slot of the transmitting gap
HS-PDSCH	<p>HSDPA: High Speed Physical Downlink Shared Channel</p> <p>The High Speed Physical Downlink Shared Channel (HSDPA) does not contain any pilot symbols. It is a channel type that is expected in code classes lower than 7. The modulation type of these channels can vary depending on the selected slot.</p> <p>HSPDSCH-QPSK_: QPSK-modulated slot of an HS PDSCH channel HSPDSCH-16QAM_: 16QAM-modulated slot of an HS PDSCH channel HSPDSCH-NONE_: slot without power of an HS PDSCH channel</p>
HS-SCCH	<p>HSDPA: High Speed Shared Control Channel</p> <p>The High Speed Shared Control Channel (HSDPA) does not contain any pilot symbols. It is a channel type that is expected in code classes equal to or higher than 7. The modulation type should always be QPSK. The channel does not contain any pilot symbols.</p> <p>If the application is configured to recognize all QPSK-modulated channels without pilot symbols (see "HSDPA/UPA" on page 63), the channels of HSDPA will be found among the data channels. If the type of a channel can be fully recognized, as for example with a DPCH (based on pilot sequences) or HS-PDSCH (based on modulation type), the type is entered in the field TYPE. All other channels without pilot symbols are of type CHAN. The channels are in descending order according to symbol rates and, within a symbol rate, in ascending order according to the channel numbers. Therefore, the unassigned codes are always to be found at the end of the table.</p> <p>If the modulation type for a channel can vary, the measured value of the modulation type will be appended to the type of the channel.</p>

Channel type	Description
EHICH-ERGCH	HSUPA: Enhanced HARQ Hybrid Acknowledgement Indicator Channel Enhanced Relative Grant Channel
EAGCH	Enhanced Absolute Grant Channel
SCPICH	Secondary Common Pilot Channel
CHAN	If the application is configured to recognize all QPSK-modulated channels without pilot symbols (see "HSDPA/UPA" on page 63), all QPSK-modulated channels without pilot symbols and a code class higher than or equal to 7 are marked with the channel type CHAN.

MIMO channel types

Optionally, single antenna MIMO measurement channels can also be detected. In this case, HS-PDSCH channels with exclusively QPSK or exclusively 16 QAM on both transport streams are automatically detected and demodulated. The corresponding channel types are denoted as "HS-MIMO-QPSK" and "HS-MIMO-16QAM".

The MIMO constellations resulting on a single antenna consist of three amplitudes per dimension (-1, 0, 1) in the case of QPSK x QPSK, and seven amplitudes per dimension (-3, -2, -1, 0, 1, 2, 3) in the case of 16 QAM x 16 QAM. The symbol decisions of these constellations can be retrieved via the bitstream output. The mapping between bits and constellation points is given by the following table.

Table 4-4: Mapping between bits and constellation points for MIMO-QPSK

Constellation point (normalized)	Bit sequence
0,0	0,1,0,1
1,0	0,1,0,0
-1,0	0,1,1,1
0,1	0,0,0,1
1,1	0,0,0,0
-1,1	0,0,1,1
0,-1	1,1,0,1
1,-1	1,1,0,0
-1,-1	1,1,1,1

For MIMO-16QAM, the bit sequence is the same in both I and Q. Only one dimension is given here.

Table 4-5: Mapping between bits and constellation points for MIMO-16QAM

Constellation point (normalized)	Bit sequence
-3	1,1,1
-2	1,1,0
-1	1,0,0

Constellation point (normalized)	Bit sequence
0	1,0,1
1	0,0,1
2	0,0,0
3	0,1,0

4.3 UE channel types

The following channel types can be detected in 3GPP FDD uplink signals by the 3GPP FDD UE application.

Control channels

The 3GPP FDD UE application expects the following control channels for the "Code Domain Power" measurements:

Table 4-6: Common 3GPP FDD UE control channels and their usage

Channel type	Description
DPCCH	The D edicated P hysical C ontrol C hannel is used to synchronize the signal. It carries pilot symbols and is expected in the Q branch at code class 8 with code number 0. This channel must be contained in every channel table.
HSDPCCH	The H igh S peed D edicated P hysical C ontrol C hannel (for HS-DCH) is used to carry control information (CQI/ACK/NACK) for downlink high speed data channels (HS-DCH). It is used in HSDPA signal setup. The symbol rate is fixed to 15ksps. The code allocation depends on the number of active DPCH. The HS-DPCCH can be switched on or off after the duration of 1/5 frame or 3 slots or 2ms. Power control is applicable too.
EDPCCH	The E nhanced D edicated P hysical C ontrol C hannel is used to carry control information for uplink high speed data channels (EDPDCH). It is used in HSUPA signal setup. The symbol rate is fixed to 15ksps.

Other channels are optional and contain the user data to be transmitted. A data channel is any channel that does not have a predefined channel number and symbol rate.

The following channel types can be detected by the 3GPP FDD UE application:

Table 4-7: Common 3GPP FDD UE data channels and their usage

Channel type	Description
DPDCH	The D edicated P hysical D ata C hannel is used to carry UPLINK data from the UE to the BS. The code allocation depends on the total required symbol rate.
EDPDCH	The E nhanced D edicated P hysical D ata C hannel is used to carry UPLINK data for high speed channels (EDPDCH). It is used in HSUPA signal setup. The symbol rate and code allocation depends on the number of DPDCH and HS-DPCCH.



As specified in 3GPP, the channel table can contain up to 6 DPDCHs or up to 4 E-DPDCHs.

4.4 3GPP FDD BTS test models

For measurements on base-station signals in line with 3GPP, test models with different channel configurations are specified in the document "Base station conformance testing (FDD)" (3GPP TS 25.141 V5.7.0). An overview of the test models is provided here.

Table 4-8: Test model 1

Channel type	Number of channels	Power (%)	Level (dB)	Spreading code	Timing offset (x256Tchip)
PCCPCH+SCH	1	10	-10	1	0
Primary CPICH	1	10	-10	0	0
PICH	1	1.6	-18	16	120
SCCPCH (SF=256)	1	1.6	-18	3	0
DPCH (SF=128)	16/32/64	76.8 total	see TS 25.141	see TS 25.141	see TS 25.141

Table 4-9: Test model 2

Channel type	Number of channels	Power (%)	Level (dB)	Spreading code	Timing offset (x256Tchip)
PCCPCH+SCH	1	10	-10	1	0
Primary CPICH	1	10	-10	0	0
PICH	1	5	-13	16	120
SCCPCH (SF=256)	1	5	-13	3	0
DPCH (SF=128)	3	2 x 10, 1 x 50	2 x -10, 1 x -3	24, 72, 120	1, 7, 2

Table 4-10: Test model 3

Channel type	Number of channels	Power (%) 16/32	Level (dB) 16/32	Spreading code	Timing offset (x256Tchip)
PCCPCH+SCH	1	12.6/7.9	-9/-11	1	0
Primary CPICH	1	12.6/7.9	-9/-11	0	0
PICH	1	5/1.6	-13/-18	16	120
SCCPCH (SF=256)	1	5/1.6	-13/-18	3	0
DPCH (SF=256)	16/32	63,7/80,4 total	see TS 25.141	see TS 25.141	see TS 25.141

Table 4-11: Test model 4

Channel type	Number of channels	Power (%) 16/32	Level (dB) 16/32	Spreading code	Timing offset (×256Tchip)
PCCPCH+SCH	1	50 to 1.6	-3 to -18	1	0
Primary CPICH*	1	10	-10	0	0

Table 4-12: Test model 5

Channel type	Number of channels	Power (%)	Level (dB)	Spreading code	Timing offset (×256Tchip)
PCCPCH+SCH	1	7.9	-11	1	0
Primary CPICH	1	7.9	-11	0	0
PICH	1	1.3	-19	16	120
SCCPCH (SF=256)	1	1.3	-19	3	0
DPCH (SF=256)	30/14/6	14/14.2/14.4 total	see TS 25.141	see TS 25.141	see TS 25.141
HS_SCCH	2	4 total	see TS 25.141	see TS 25.141	see TS 25.141
HS_PDSCH (16QAM)	8/4/2	63.6/63.4/63.2 total	see TS 25.141	see TS 25.141	see TS 25.141

4.5 Setup for base station tests

This section describes how to set up the analyzer for 3GPP FDD BTS tests. As a prerequisite for starting the test, the FSW must be correctly set up and connected to the AC power supply as described in the instrument's Getting Started manual. Furthermore, the 3GPP FDD BTS application must be available.

Standard Test Setup

- Connect the antenna output (or Tx output) of the BTS to the RF input of the analyzer via a power attenuator of suitable attenuation.
The following values are recommended for the external attenuator to ensure that the RF input of the analyzer is protected and the sensitivity of the analyzer is not reduced too much.

Max. power	Recommended ext. attenuation
≥55 to 60 dBm	35 to 40 dB
≥50 to 55 dBm	30 to 35 dB
≥45 to 50 dBm	25 to 30 dB
≥40 to 45 dBm	20 to 25 dB
≥35 to 40 dBm	15 to 20 dB

Max. power	Recommended ext. attenuation
≥30 to 35 dBm	10 to 15 dB
≥25 to 30 dBm	5 to 10 dB
≥20 to 25 dBm	0 to 5 dB
<20 dBm	0 dB

- For signal measurements at the output of two-port networks, connect the reference frequency of the signal source to the rear reference input of the analyzer (EXT REF IN/OUT).
- To ensure that the error limits specified by the 3GPP standard are met, the analyzer should use an external reference frequency for frequency measurements on base stations. For instance, a rubidium frequency standard may be used as a reference source.
- If the base station is provided with a trigger output, connect this output to the trigger input of the analyzer.

Presetting

Configure the FSW as follows:

- Set the external attenuation (Reference level offset).
- Set the reference level.
- Set the center frequency.
- Set the trigger.
- Select the BTS standard and measurement.

4.6 3GPP FDD UE test models

The possible channel configurations for the mobile station signal are limited by 3GPP. Only two different configurations for data channels DPDCH are permissible according to the specification. In addition to these two channel configurations, the HS-DPCCH channel can be transmitted to operate the mobile station in HSDPA mode. Thus, the 3GPP FDD UE application checks for these channel configurations only during the automatic channel search. Therefore, channels whose parameters do not correspond to one of these configurations are not automatically detected as active channels.

The two possible channel configurations are summarized below:

Table 4-13: Channel configuration 1: DPCCH and 1 DPDCH

Channel type	Number of channels	Symbol rate	Spreading code(s)	Mapping
DPCCH	1	15 ksps	0	Q
DPDCH	1	15 ksps – 960 ksps	[spreading-factor/4]	I

Table 4-14: Channel configuration 2: DPCCH and up to 6 DPDCH

Channel type	Number of channels	Symbol rate	Spreading code(s)	Mapping
DPCCH	1	15 ksps	0	Q
DPDCH	1	960 ksps	1	I
DPDCH	1	960 ksps	1	Q
DPDCH	1	960 ksps	3	I
DPDCH	1	960 ksps	3	Q
DPDCH	1	960 ksps	2	I
DPDCH	1	960 ksps	2	Q

Table 4-15: Channel configuration 3: DPCCH, up to 6 DPDCH and 1 HS-DPCCH The channel configuration is as above in table 4-2. On HS-DPCCH is added to each channel table.

Number of DPDCH	Symbol rate all DPDCH	Symbol rate HS-DPCCH	Spreading code HS-DPCCH	Mapping (HS-DPCCH)
1	15 – 960 ksps	15 ksps	64	Q
2	1920 ksps	15 ksps	1	I
3	2880 ksps	15 ksps	32	Q
4	3840 ksps	15 ksps	1	I
5	4800 ksps	15 ksps	32	Q
6	5760 ksps	15 ksps	1	I

Table 4-16: Channelization code of HS-DPCCH

Nmax-dpdch (as defined in subclause 4.2.1)	Channelization code C_{ch}
1	$C_{ch,256,64}$
2,4,6	$C_{ch,256,1}$
3,5	$C_{ch,256,32}$

4.7 Setup for user equipment tests

This section describes how to set up the FSW for 3GPP FDD UE user equipment tests. As a prerequisite for starting the test, the FSW must be correctly set up and connected to the AC power supply as described in the analyzer's Getting Started manual. Furthermore, the 3GPP FDD UE application must be installed.

Standard Test Setup

- Connect antenna output (or Tx output) of UE to RF input of the analyzer via a power attenuator of suitable attenuation.

The following values are recommended for the external attenuator to ensure that the RF input of the analyzer is protected and the sensitivity of the analyzer is not reduced too much.

Max. power	Recommended ext. attenuation
³ 55 to 60 dBm	35 to 40 dB
³ 50 to 55 dBm	30 to 35 dB
³ 45 to 50 dBm	25 to 30 dB
³ 40 to 45 dBm	20 to 25 dB
³ 35 to 40 dBm	15 to 20 dB
³ 30 to 35 dBm	10 to 15 dB
³ 25 to 30 dBm	5 to 10 dB
³ 20 to 25 dBm	0 to 5 dB
<20 dBm	0 dB

- For signal measurements at the output of two-port networks, connect the reference frequency of the signal source to the external reference input connector of the analyzer ([REF INPUT]).
- To ensure that the error limits specified by the 3GPP standard are met, the analyzer should use an external reference frequency for frequency measurements on user equipment. For instance, a rubidium frequency standard may be used as a reference source.
- If the user equipment is provided with a trigger output, connect this output to one of the [trigger input] connectors of the analyzer.

Presetting

Configure the FSW as follows:

- Set the external attenuation (Reference level offset).
- Set the reference level.
- Set the center frequency.
- Set the trigger.
- Select the UE standard and measurement.

4.8 Time alignment error measurements

"Time Alignment Error" Measurements are a special type of Code Domain Analysis used to determine the time offset between signals on different antennas in a base station and different base stations. They can be performed for the two transmitter branches of a BTS as well as for the transmit signals of multiple base stations on differ-

ent transmit frequencies. The time alignment error is relevant, for instance, for WCDMA base stations using TX diversity or MIMO configurations.

- [Measurement setup for two antennas in a base station](#)..... 55
- [Measurement setup for transmit signals from multiple base Stations](#).....55

4.8.1 Measurement setup for two antennas in a base station

The antenna signals of the two BTS transmitter branches are fed to the analyzer via a combiner. Each antenna must provide a common pilot channel, i.e. P-CPICH for antenna 1 and P-CPICH or S-CPICH for antenna 2. The [Time Alignment Error Measurement setup for one base station using an FSW](#) shows the measurement setup.

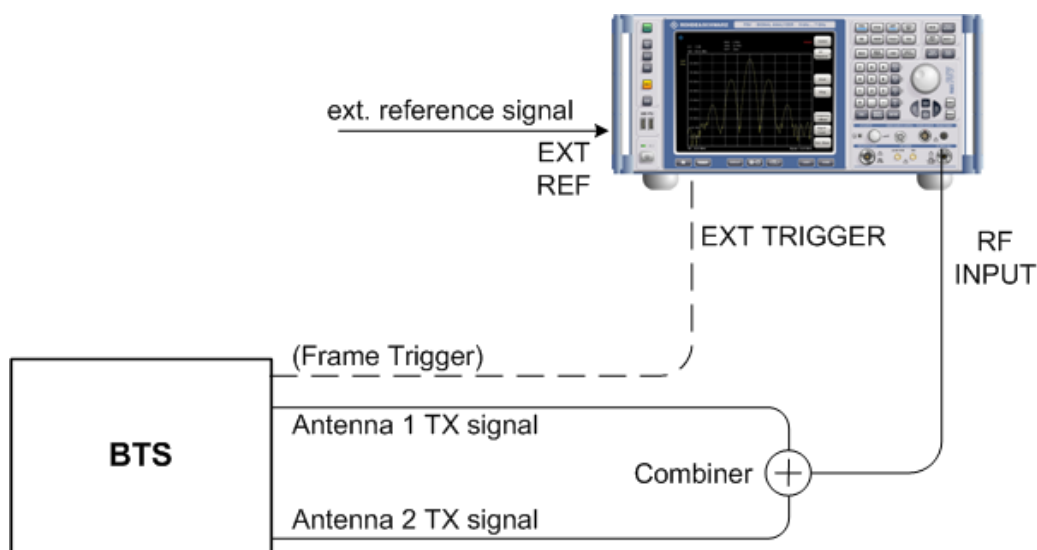

Figure 4-1: Time Alignment Error Measurement setup for one base station using an FSW

Synchronization check

A synchronization check is performed for both antennas which must have the result "Sync OK" to ensure a proper TAE result. Synchronization problems are indicated by the messages "No antenna 1 sync", "No antenna 2 sync" and "No sync". Errors can also be read remotely via bits 1 and 2 of the `Sync` status register (see [Chapter 11.13, "Querying the status registers"](#), on page 288).

4.8.2 Measurement setup for transmit signals from multiple base Stations

All of the signals must be superimposed in a similar way to the measurement with a single base station, prior to feeding them into the spectrum analyzer's RF input. The signals from the different base stations can each include one or both of the transmit antennas. Here too, all of the signals on all of the antennas to be tested must provide a common pilot channel: P-CPICH for all signals on antenna 1, P-CPICH or S-CPICH for signals on antenna 2.

Carrier tables

The number of base stations and the transmit frequency of the base stations can be defined using a table. You can define a table interactively in the R&S FSW 3GPP FDD Measurements application, using remote commands, or offline by defining an xml file with a specified structure. A template for such a file is provided with the R&S FSW 3GPP FDD Measurements application.

A default table ("RECENT") is always available and cannot be deleted.

Carriers and reference carrier

The measurement can be performed for base station signals on different transmit frequencies for up to 4 signals. One carrier must be defined as the reference carrier for the time alignment error results. Based on the maximum spacing for the base stations set in the table, the R&S FSW 3GPP FDD Measurements application determines the necessary bandwidth and sampling rate. The smallest possible bandwidth and sampling rate are always used.

Carrier frequencies

Carriers are defined by their frequencies, or more precisely: as frequency offsets to the reference carrier. The reference carrier itself is set to the current center frequency, thus the offset is always 0.

The **minimum spacing** between two carriers is 2.5 MHz. If this minimum spacing is not maintained, a conflict is indicated.

The **maximum positive and negative frequency offset** which a carrier can have from the reference depends on the available analysis bandwidth.

- FSW with no bandwidth extension options: 1 carrier only (multi-carrier not available)
- FSW with bandwidth extension option B28: ± 5.5 MHz
- FSW with bandwidth extension option B40: ± 17.5 MHz
- FSW with bandwidth extension option B80: ± 37.5 MHz
- FSW with bandwidth extension option B160 or higher: ± 61.5 MHz

If the maximum offsets from the reference are exceeded, a conflict is indicated.

Carrier details

For each base station to be tested, the scrambling code, CPICH number and patterns used on both antennas must be known in order to enable synchronization to the signal for this antenna.

4.9 I/Q data import and export

Baseband signals mostly occur as so-called complex baseband signals, i.e. a signal representation that consists of two channels; the inphase (I) and the quadrature (Q) channel. Such signals are referred to as I/Q signals. The complete modulation informa-

tion and even distortion that originates from the RF, IF or baseband domains can be analyzed in the I/Q baseband.



Importing and exporting I/Q signals is useful for various applications:

- Generating and saving I/Q signals in an RF or baseband signal generator or in external software tools to analyze them with the FSW later.
The FSW supports various I/Q data formats for import.
For details on formats, see the FSW I/Q Analyzer and I/Q Input user manual.
- Capturing and saving I/Q signals with the FSW to analyze them with the FSW or an external software tool later
As opposed to storing trace data, which can be averaged or restricted to peak values, I/Q data is stored as it was captured, without further processing. Multi-channel data is not supported.
The data is stored as complex values in 32-bit floating-point format.
The file type is determined by the file extension. If no file extension is provided, the file type is assumed to be `.iq.tar`. For `.mat` files, Matlab® v4 is assumed.
For a detailed description, see the FSW I/Q Analyzer and I/Q Input User Manual.



An application note on converting Rohde & Schwarz I/Q data files is available from the Rohde & Schwarz website:

[1EF85: Converting R&S I/Q data files](#)

The import and export functions are available in the "Save/Recall" menu which is displayed when you select the  "Save" or  "Open" icon in the toolbar.

See the FSW I/Q Analyzer and I/Q Input User Manual.



Export only in MSRA mode

In MSRA mode, I/Q data can only be exported to other applications; I/Q data cannot be imported to the MSRA primary or any MSRA secondary applications.

4.10 CDA measurements in MSRA operating mode

The 3GPP FDD BTS application can also be used to analyze data in MSRA operating mode.

In MSRA operating mode, only the MSRA primary actually captures data; the MSRA applications receive an extract of the captured data for analysis, referred to as the **application data**. For the 3GPP FDD BTS application in MSRA operating mode, the application data range is defined by the same settings used to define the signal capture in Signal and Spectrum Analyzer mode. In addition, a capture offset can be defined, i.e. an offset from the start of the captured data to the start of the analysis interval for the 3GPP FDD BTS measurement.

Data coverage for each active application

Generally, if a signal contains multiple data channels for multiple standards, separate applications are used to analyze each data channel. Thus, it is of interest to know which application is analyzing which data channel. The MSRA primary display indicates the data covered by each application, restricted to the channel bandwidth used by the corresponding standard (for 3GPP FDD: 5 MHz), by vertical blue lines labeled with the application name.

Analysis interval

However, the individual result displays of the application need not analyze the complete data range. The data range that is actually analyzed by the individual result display is referred to as the **analysis interval**.

In the 3GPP FDD BTS application the analysis interval is automatically determined according to the selected channel, slot or frame to analyze which is defined for the evaluation range, depending on the result display. The analysis interval can not be edited directly in the 3GPP FDD BTS application, but is changed automatically when you change the evaluation range.

Analysis line

A frequent question when analyzing multi-standard signals is how each data channel is correlated (in time) to others. Thus, an analysis line has been introduced. The analysis line is a common time marker for all MSRA secondary applications. It can be positioned in any MSRA secondary application or the MSRA primary and is then adjusted in all other secondary applications. Thus, you can easily analyze the results at a specific time in the measurement in all secondary applications and determine correlations.

If the analysis interval of the secondary application contains the marked point in time, the line is indicated in all time-based result displays, such as time, symbol, slot or bit diagrams. By default, the analysis line is displayed. However, you can hide it from view manually. In all result displays, the "AL" label in the window title bar indicates whether the analysis line lies within the analysis interval or not:

- **orange "AL"**: the line lies within the interval
- **white "AL"**: the line lies within the interval, but is not displayed (hidden)
- **no "AL"**: the line lies outside the interval

For details on the MSRA operating mode see the FSW MSRA User Manual.

5 Configuration

The 3GPP FDD applications provide several different measurements for signals according to the 3GPP FDD application. The main and default measurement is Code Domain Analysis. Furthermore, a "Time Alignment Error" measurement is provided. In addition to the code domain power measurements specified by the 3GPP standard, the 3GPP FDD options offer measurements with predefined settings in the frequency domain, e.g. RF power measurements.

Only one measurement type can be configured per channel; however, several channels with 3GPP FDD applications can be configured in parallel on the . Thus, you can configure one channel for a Code Domain Analysis, for example, and another for a "Time Alignment Error" or Power FSW measurement for the same input signal. Then you can use the Sequencer to perform all measurements consecutively and either switch through the results easily or monitor all results at the same time in the "Multi-View" tab.

For details on the Sequencer function see the FSW User Manual.

Selecting the measurement type

When you activate an 3GPP FDD application, Code Domain Analysis of the input signal is started automatically. However, the 3GPP FDD applications also provide other measurement types.

► To select a different measurement type, do one of the following:

- In the "Overview", select "Select Measurement". Select the required measurement.
- Press [MEAS]. In the "Select Measurement" dialog box, select the required measurement.

● Result display	59
● Code domain analysis	60
● Time alignment error measurements	102
● RF measurements	108

5.1 Result display

The captured signal can be displayed using various evaluation methods. All evaluation methods available for 3GPP FDD applications are displayed in the evaluation bar in SmartGrid mode when you do one of the following:

- Select the  "SmartGrid" icon from the toolbar.
- Select "Display" in the "Overview".
- Press [MEAS].
- Select "Display Config" in any 3GPP FDD menu.

Up to 16 evaluation methods can be displayed simultaneously in separate windows. The 3GPP FDD evaluation methods are described in [Chapter 3.1.2, "Evaluation methods for code domain analysis"](#), on page 19.

To close the SmartGrid mode and restore the previous softkey menu select the  "Close" icon in the righthand corner of the toolbar, or press any key.



For details on working with the SmartGrid see the FSW Getting Started manual.

5.2 Code domain analysis

Access: [MODE] > "3G FDD BTS"/ "3G FDD UE"

3GPP FDD measurements require special applications on the FSW.



When you activate a 3GPP FDD application the first time, a set of parameters is passed on from the currently active application:

- center frequency and frequency offset
- reference level and reference level offset
- attenuation

After initial setup, the parameters for the measurement channel are stored upon exiting and restored upon re-entering the channel. Thus, you can switch between applications quickly and easily.

When you activate a 3GPP FDD application, Code Domain Analysis of the input signal is started automatically with the default configuration. The "Code Domain Analyzer" menu is displayed and provides access to the most important configuration functions.



The "Span", "Bandwidth", "Lines", and "Marker Functions" menus are not available in 3GPP FDD applications.

Code Domain Analysis can be configured easily in the "Overview" dialog box, which is displayed when you select "Overview" from any menu.



Importing and Exporting I/Q Data

Access:  "Save/Recall" menu > "Import I/Q"/ "Export I/Q"

The 3GPP FDD applications can not only measure the 3GPP FDD I/Q data to be evaluated. They can also import I/Q data, provided it has the correct format. Furthermore, the evaluated I/Q data from the 3GPP FDD applications can be exported for further analysis in external applications.

For details on importing and exporting I/Q data, see the FSW User Manual.

• Configuration overview.....	61
• Signal description.....	62
• Data input and output settings.....	67
• Frontend settings.....	74
• Trigger settings.....	81
• Signal capture (data acquisition).....	86
• Application data (MSRA).....	89
• Synchronization (BTS measurements only).....	89
• Channel detection.....	91
• Sweep settings.....	98
• Automatic settings.....	100

5.2.1 Configuration overview



Access: [Meas Config] > "Overview"

Throughout the measurement configuration, an overview of the most important currently defined settings is provided in the "Overview".

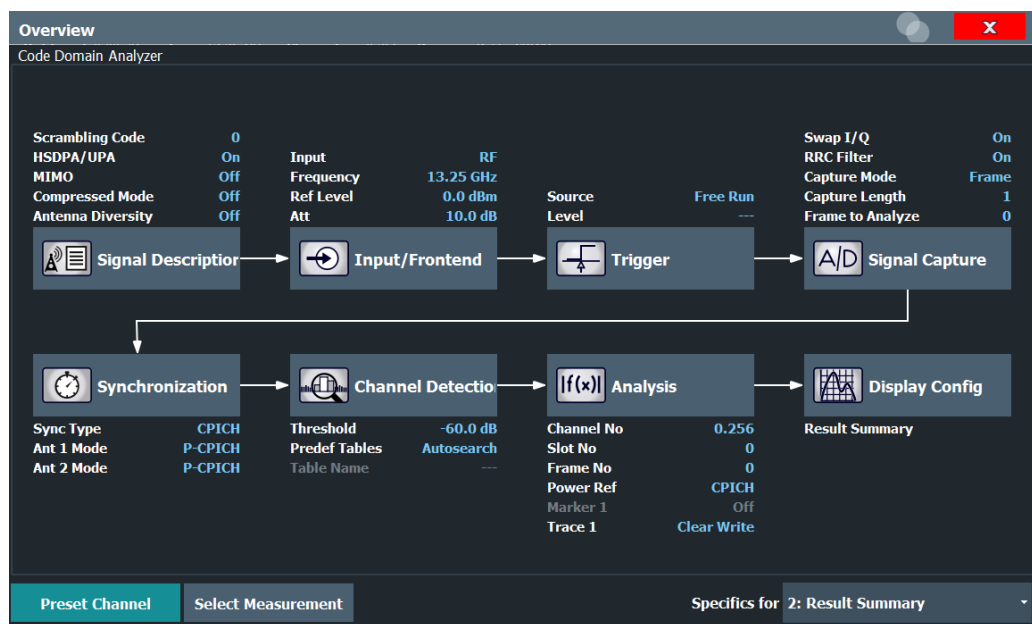

Figure 5-1: Configuration "Overview" for CDA measurements

In addition to the main measurement settings, the "Overview" provides quick access to the main settings dialog boxes. Thus, you can easily configure an entire measurement channel from input over processing to evaluation by stepping through the dialog boxes as indicated in the "Overview".



The available settings and functions in the "Overview" vary depending on the currently selected measurement.

For "Time Alignment Error" Measurements see [Chapter 5.3.1, "Configuration overview"](#), on page 102.

For RF measurements see [Chapter 5.4, "RF measurements"](#), on page 108.

To configure settings

- ▶ Select any button in the "Overview" to open the corresponding dialog box. Select a setting in the channel bar (at the top of the measurement channel tab) to change a specific setting.

Preset Channel	62
Select Measurement	62
Specific Settings for	62

Preset Channel

Select "Preset Channel" in the lower left-hand corner of the "Overview" to restore all measurement settings *in the current channel* to their default values.

Note: Do not confuse "Preset Channel" with the [Preset] key, which restores the entire instrument to its default values and thus closes *all channels* on the FSW (except for the default channel)!

Remote command:

[SYSTem:PRESet:CHANnel \[:EXEC\]](#) on page 159

Select Measurement

Selects a different measurement to be performed.

See [Chapter 3, "Measurements and result display"](#), on page 16.

Specific Settings for

The channel can contain several windows for different results. Thus, the settings indicated in the "Overview" and configured in the dialog boxes vary depending on the selected window.

Select an active window from the "Specific Settings for" selection list that is displayed in the "Overview" and in all window-specific configuration dialog boxes.

The "Overview" and dialog boxes are updated to indicate the settings for the selected window.

5.2.2 Signal description

Access: "Overview" > "Signal Description"

or: [MEAS CONFIG] > "Signal Description"

The signal description provides information on the expected input signal.

- [BTS signal description](#)..... 63
- [BTS scrambling code](#)..... 64
- [UE signal description \(UE measurements\)](#)..... 66

5.2.2.1 BTS signal description

Access: "Overview" > "Signal Description"

or: [MEAS CONFIG] > "Signal Description"

The settings available to describe the input signal in BTS measurements are described here.

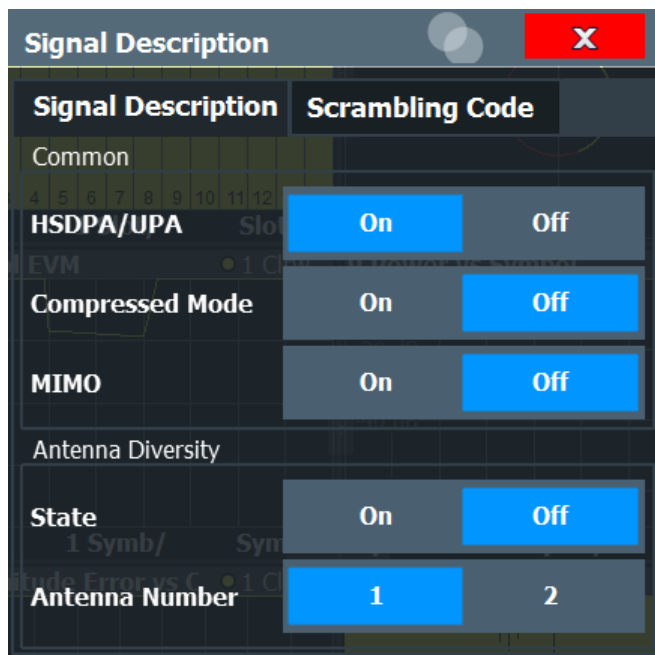

- [HSDPA/UPA](#)..... 63
- [Compressed Mode](#)..... 64
- [MIMO](#)..... 64
- [Antenna Diversity](#)..... 64
- [Antenna Number](#)..... 64

HSDPA/UPA

If enabled, the application detects all QPSK-modulated channels without pilot symbols (HSDPA channels) and displays them in the channel table. If the type of a channel can be fully recognized, as for example with a HS-PDSCH (based on modulation type), the type is indicated in the table. All other channels without pilot symbols are of type "CHAN".

Remote command:

[SENSe:] CDPower:HSDPamode on page 162

Compressed Mode

If compressed mode is switched on, some slots of a channel are suppressed. To keep the overall data rate, the slots just before or just behind a compressed gap can be sent with half spreading factor (SF/2). This mode must be enabled to detect compressed mode channels (see [Chapter 4.2, "BTS channel types"](#), on page 45).

Remote command:

[\[SENSe:\]CDPower:PCONtrol](#) on page 164

MIMO

Activates or deactivates single antenna MIMO measurement mode.

If activated, HS-PDSCH channels with exclusively QPSK or exclusively 16 QAM on both transport streams are automatically detected and demodulated. The corresponding channel types are denoted as "HS-MIMO-QPSK" and "HS-MIMO-16QAM", respectively.

For details see ["MIMO channel types"](#) on page 48.

Remote command:

[\[SENSe:\]CDPower:MIMO](#) on page 163

Antenna Diversity

This option switches the antenna diversity mode on and off.

Remote command:

[\[SENSe:\]CDPower:ANTenna](#) on page 161

Antenna Number

This option switches between diversity antennas 1 and 2. Depending on the selected setting, the 3GPP FDD application synchronizes to the CPICH of antenna 1 or antenna 2.

Remote command:

[\[SENSe:\]CDPower:ANTenna](#) on page 161

5.2.2.2 BTS scrambling code

Access: "Overview" > "Signal Description" > "Scrambling Code" tab

or: [MEAS CONFIG] > "Signal Description" > "Scrambling Code" tab

The scrambling code identifies the base station transmitting the signal. You can either define the used scrambling code manually, or perform a search on the input signal to detect a list of possible scrambling codes automatically.

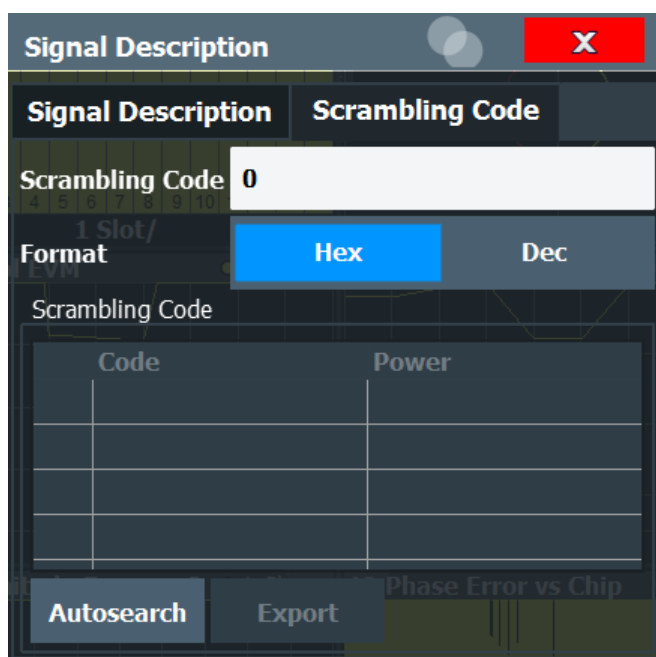

Scrambling Code.....65
 Format Hex/Dec..... 65
 Scrambling Codes.....65
 Autosearch for Scrambling Code..... 65
 Export.....66

Scrambling Code

Defines the scrambling code. The scrambling codes are used to distinguish between different base stations. Each base station has its own scrambling code.

Remote command:

[SENSe:]CDPower:LCODE:DVALue on page 164

Format Hex/Dec

Switch the display format of the scrambling codes between hexadecimal and decimal.

Remote command:

[SENSe:]CDPower:LCODE:DVALue on page 164

[SENSe:]CDPower:LCODE[:VALue] on page 165

Scrambling Codes

This table includes all found scrambling codes from the last autosearch sequence. In the first column each detected scrambling code can be selected for export.

Remote command:

[SENSe:]CDPower:LCODE:SEARch:LIST on page 163

Autosearch for Scrambling Code

Starts a search on the measured signal for all scrambling codes. The scrambling code that leads to the highest signal power is chosen as the new scrambling code.

Searching requires that the correct center frequency and level are set. The scrambling code search can automatically determine the primary scrambling code number. The secondary scrambling code number is expected as 0. Alternative scrambling codes can not be detected. Therefore the range for detection is 0x0000 – 0x1FF0h, where the last digit is always 0.

Remote command:

[SENSe:]CDPower:LCODE:SEARCH[:IMMEDIATE] on page 162

Export

Writes the detected scrambling codes together with their powers into a text file in the R&S user directory (C:\R_S\INSTR\USER\ScrCodes.txt)

5.2.2.3 UE signal description (UE measurements)

Access: "Overview" > "Signal Description" > "Signal Description"

or: [MEAS CONFIG] > "Signal Description"

The settings available to describe the input signal in UE measurements are described here.

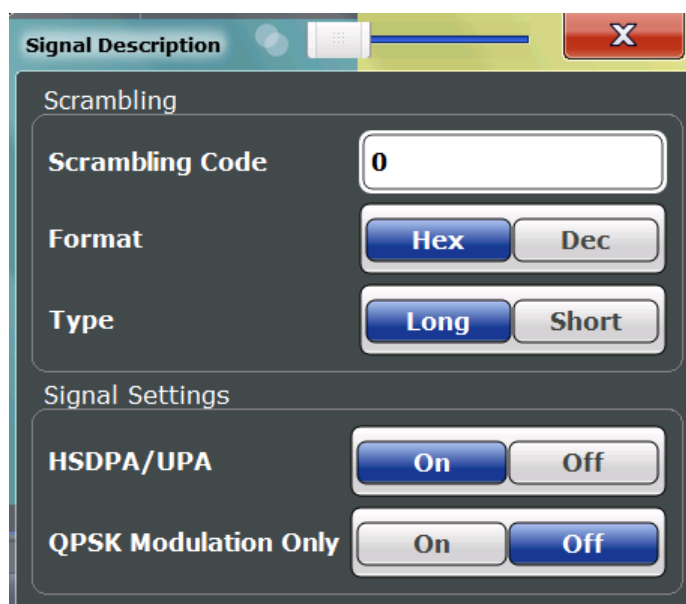

Scrambling Code.....	66
Format.....	67
Type.....	67
HSDPA/UPA.....	67
QPSK Modulation Only.....	67

Scrambling Code

Defines the scrambling code used to transmit the signal in the specified format.

The scrambling code identifies the user equipment transmitting the signal. If an incorrect scrambling code is defined, a CDP measurement of the signal is not possible.

Remote command:

[\[SENSe:\]CDPower:LCODE\[:VALue\]](#) on page 165

Format

Switches the display format of the scrambling codes between hexadecimal and decimal.

Remote command:

[SENS:CDP:LCOD:DVAL <numeric value>](#) (see [\[SENSe:\]CDPower:LCODE:DVALue](#) on page 164)

Type

Defines whether the entered scrambling code is to be handled as a long or short scrambling code.

Remote command:

[\[SENSe:\]CDPower:LCODE:TYPE](#) on page 165

HSDPA/UPA

If enabled, the application detects all QPSK-modulated channels without pilot symbols (HSDPA channels) and displays them in the channel table. If the type of a channel can be fully recognized, as for example with a HS-PDSCH (based on modulation type), the type is indicated in the table. All other channels without pilot symbols are of type "CHAN".

Remote command:

[\[SENSe:\]CDPower:HSDPamode](#) on page 162

QPSK Modulation Only

If enabled, it is assumed that the signal uses QPSK modulation only. Thus, a special QPSK-based synchronization can be performed and the measurement therefore runs with optimized speed.

Do not enable this mode for signals that do not use QPSK modulation.

Remote command:

[\[SENSe:\]CDPower:QPSKonly](#) on page 166

5.2.3 Data input and output settings

Access: "Overview" > "Input/Frontend"

or: [INPUT/OUTPUT]

The FSW can analyze signals from different input sources and provide various types of output (such as noise or trigger signals).



Input from other sources

The R&S FSW 3GPP FDD Measurements application application can also process input from the following optional sources:

- I/Q Input files
- "Digital Baseband" interface
- "Analog Baseband" interface
- Probes

For details, see the FSW I/Q Analyzer and I/Q Input User Manual.

- [Radio frequency input](#)..... 68
- [Output settings](#)..... 71
- [Digital I/Q output settings](#)..... 72

5.2.3.1 Radio frequency input

Access: "Overview" > "Input/Frontend" > "Input Source" > "Radio Frequency"

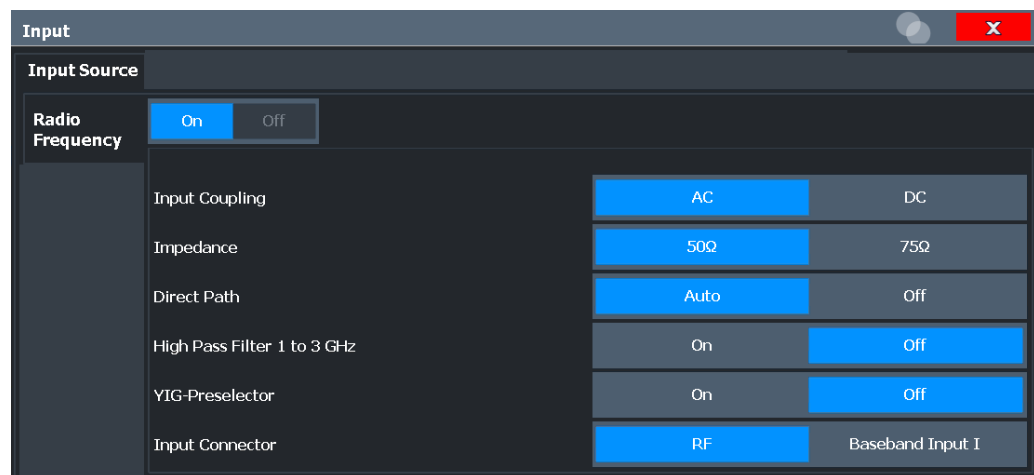

RF Input Protection

The RF input connector of the FSW must be protected against signal levels that exceed the ranges specified in the specifications document. Therefore, the FSW is equipped with an overload protection mechanism for DC and signal frequencies up to 30 MHz. This mechanism becomes active as soon as the power at the input mixer exceeds the specified limit. It ensures that the connection between RF input and input mixer is cut off.

When the overload protection is activated, an error message is displayed in the status bar ("INPUT OVLD"), and a message box informs you that the RF input was disconnected. Furthermore, a status bit (bit 3) in the `STAT:QUES:POW` status register is set. In this case, you must decrease the level at the RF input connector and then close the message box. Then measurement is possible again. Reactivating the RF input is also possible via the remote command `INPut:ATTenuation:PROTection:RESet`.

Radio Frequency State.....	69
Input Coupling.....	69
Impedance.....	69
Direct Path.....	70
High Pass Filter 1 to 3 GHz.....	70
YIG-Preselector.....	70
Input Connector.....	71

Radio Frequency State

Activates input from the "RF Input" connector.

For FSW85 models with two input connectors, you must define which input source is used for each measurement channel.

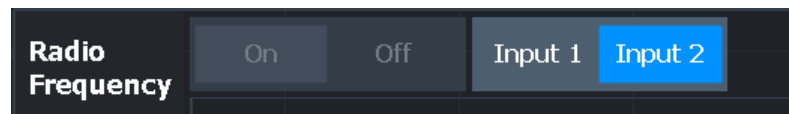

"Input 1" 1.00 mm RF input connector for frequencies up to 85 GHz (90 GHz with option R&S FSW-B90G)

"Input 2" 1.85 mm RF input connector for frequencies up to 67 GHz

Remote command:

[INPut:SElect](#) on page 169

[INPut:TYPE](#) on page 170

Input Coupling

The RF input of the FSW can be coupled by alternating current (AC) or direct current (DC).

Not available for input from the optional "Analog Baseband" interface.

Not available for input from the optional "Digital Baseband" interface.

AC coupling blocks any DC voltage from the input signal. AC coupling is activated by default to prevent damage to the instrument. Very low frequencies in the input signal can be distorted.

However, some specifications require DC coupling. In this case, you must protect the instrument from damaging DC input voltages manually. For details, refer to the specifications document.

Remote command:

[INPut:COUPling](#) on page 167

Impedance

For some measurements, the reference impedance for the measured levels of the FSW can be set to 50 Ω or 75 Ω.

Select 75 Ω if the 50 Ω input impedance is transformed to a higher impedance using a 75 Ω adapter of the RAZ type. (That corresponds to 25Ω in series to the input impedance of the instrument.) The correction value in this case is 1.76 dB = 10 log (75Ω/50Ω).

This value also affects the unit conversion (see "[Reference Level](#)" on page 75).

Not available for input from the optional "Digital Baseband" interface.

Not available for input from the optional "Analog Baseband" interface. For analog baseband input, an impedance of 50 Ω is always used.

Remote command:

[INPut:IMPedance](#) on page 169

Direct Path

Enables or disables the use of the direct path for small frequencies.

In spectrum analyzers, passive analog mixers are used for the first conversion of the input signal. In such mixers, the LO signal is coupled into the IF path due to its limited isolation. The coupled LO signal becomes visible at the RF frequency 0 Hz. This effect is referred to as LO feedthrough.

To avoid the LO feedthrough the spectrum analyzer provides an alternative signal path to the A/D converter, referred to as the *direct path*. By default, the direct path is selected automatically for RF frequencies close to zero. However, this behavior can be disabled. If "Direct Path" is set to "Off", the spectrum analyzer always uses the analog mixer path.

"Auto" (Default) The direct path is used automatically for frequencies close to zero.

"Off" The analog mixer path is always used.

Remote command:

[INPut:DPATH](#) on page 168

High Pass Filter 1 to 3 GHz

Activates an additional internal highpass filter for RF input signals from 1 GHz to 3 GHz. This filter is used to remove the harmonics of the analyzer to measure the harmonics for a DUT, for example.

This function requires an additional hardware option.

Note: For RF input signals outside the specified range, the high-pass filter has no effect. For signals with a frequency of approximately 4 GHz upwards, the harmonics are suppressed sufficiently by the YIG-preselector, if available.)

Remote command:

[INPut:FILTer:HPASs\[:STATE\]](#) on page 168

YIG-Preselector

Enables or disables the YIG-preselector.

An internal YIG-preselector at the input of the FSW ensures that image frequencies are rejected. However, image rejection is only possible for a restricted bandwidth. To use the maximum bandwidth for signal analysis you can disable the YIG-preselector at the input of the FSW, which can lead to image-frequency display.

Note: Note that the YIG-preselector is active only on frequencies greater than 8 GHz. Therefore, switching the YIG-preselector on or off has no effect if the frequency is below that value.

To use the optional 90 GHz frequency extension (R&S FSW-B90G), the YIG-preselector must be disabled.

The "YIG-Preselector" is off by default.

Remote command:

`INPut:FILTer:YIG[:STATe]` on page 168

Input Connector

Determines which connector the input data for the measurement is taken from.

For more information on the optional "Analog Baseband" interface, see the FSW I/Q Analyzer and I/Q Input user manual.

"RF"	(Default:) The "RF Input" connector
"RF Probe"	The "RF Input" connector with an adapter for a modular probe This setting is only available if a probe is connected to the "RF Input" connector.
"Baseband Input 1"	The optional "Baseband Input 1" connector This setting is only available if the optional "Analog Baseband" interface is installed and active for input. It is not available for the FSW67. For FSW85 models with two input connectors, this setting is only available for "Input 1".

Remote command:

`INPut:CONNector` on page 167

5.2.3.2 Output settings

Access: [Input/Output] > "Output"

The FSW can provide output to special connectors for other devices.

For details on connectors, refer to the FSW Getting Started manual, "Front / Rear Panel View" chapters.



How to provide trigger signals as output is described in detail in the FSW base unit user manual.

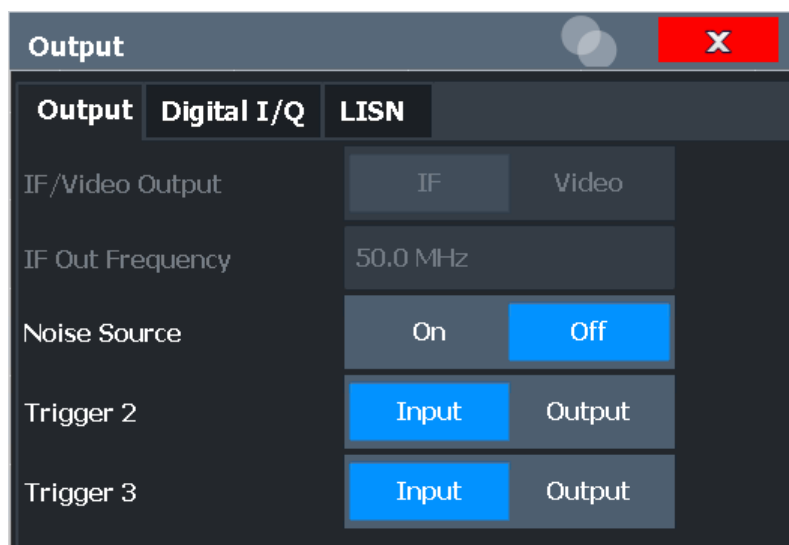

Noise Source Control..... 72

Noise Source Control

Enables or disables the 28 V voltage supply for an external noise source connected to the "Noise source control / Power sensor") connector. By switching the supply voltage for an external noise source on or off in the firmware, you can enable or disable the device as required.

External noise sources are useful when you are measuring power levels that fall below the noise floor of the FSW itself, for example when measuring the noise level of an amplifier.

In this case, you can first connect an external noise source (whose noise power level is known in advance) to the FSW and measure the total noise power. From this value, you can determine the noise power of the FSW. Then when you measure the power level of the actual DUT, you can deduct the known noise level from the total power to obtain the power level of the DUT.

Remote command:

[DIAGnostic:SERvice:NSource](#) on page 187

5.2.3.3 Digital I/Q output settings

Access: "Overview" > "Output" > "Digital I/Q" tab

The optional "Digital Baseband" interface allows you to output I/Q data from any FSW application that processes I/Q data to an external device.

These settings are only available if the "Digital Baseband" interface option is installed on the FSW.



Digital I/Q output is available with bandwidth extension option FSW-B512, but not with R&S FSW-B512R (Real-Time).

However, see the note regarding digital I/Q output and the FSW-B512 option in the FSW I/Q Analyzer and I/Q Input User Manual.

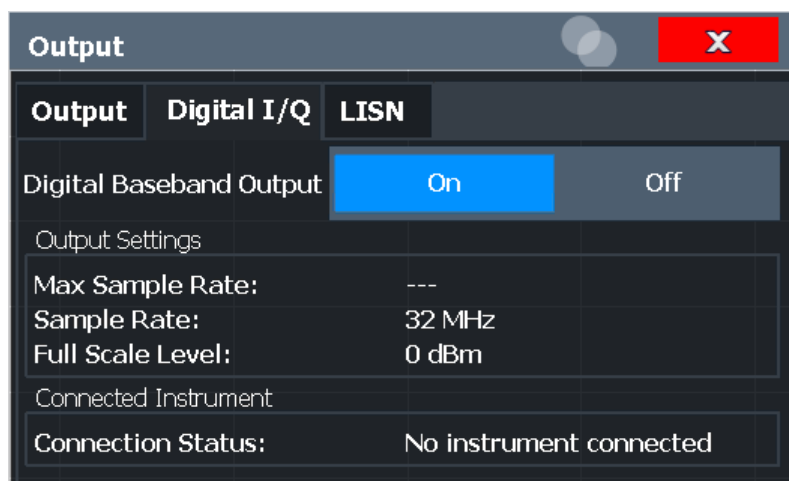

For details on digital I/Q output, see the FSW I/Q Analyzer User Manual.

Digital Baseband Output	73
Output Settings Information	73
Connected Instrument	73

Digital Baseband Output

Enables or disables a digital output stream to the optional "Digital Baseband" interface, if available.

Note: If digital baseband output is active, the sample rate is restricted to 200 MHz (max. 160 MHz bandwidth).

The only data source that can be used for digital baseband output is RF input.

For details on digital I/Q output, see the FSW I/Q Analyzer User Manual.

Remote command:

`OUTPut:DIQ[:STATe]` on page 174

Output Settings Information

Displays information on the settings for output via the optional "Digital Baseband" interface.

The following information is displayed:

- Maximum sample rate that can be used to transfer data via the "Digital Baseband" interface (i.e. the maximum input sample rate that can be processed by the connected instrument)
- Sample rate currently used to transfer data via the "Digital Baseband" interface
- Level and unit that corresponds to an I/Q sample with the magnitude "1"

Remote command:

`OUTPut<up>:DIQ:CDEvice?` on page 175

Connected Instrument

Displays information on the instrument connected to the optional "Digital Baseband" interface, if available.

If an instrument is connected, the following information is displayed:

- Name and serial number of the instrument connected to the "Digital Baseband" interface
- Used port

Remote command:

`OUTPut<up>:DIQ:CDEvice?` on page 175

5.2.4 Frontend settings

Access: "Overview" > "Input/Frontend"

Frequency, amplitude and y-axis scaling settings represent the "frontend" of the measurement setup.



Amplitude settings for analog baseband input

Amplitude settings for analog baseband input are described in the FSW I/Q Analyzer and I/Q Input User Manual

• Amplitude settings	74
• Y-axis scaling	78
• Frequency settings	79

5.2.4.1 Amplitude settings

Access: "Overview" > "Input/Frontend" > "Amplitude"

Amplitude settings determine how the FSW must process or display the expected input power levels.

Configuring amplitude settings allows you to:

- Adapt the instrument hardware to the expected maximum signal level by setting the [Reference Level](#) to this maximum
- Consider an external attenuator or preamplifier (using the "Offset").
- Optimize the SNR of the measurement for low signal levels by configuring the [Reference Level](#) as high as possible without introducing compression, clipping or overload. Use early amplification by the preamplifier and a low attenuation.
- Optimize the SNR for high signal levels and ensure that the instrument hardware is not damaged, using high attenuation and AC coupling (for DC input voltage).
- Adapt the reference impedance for power results when measuring in a 75-Ohm system by connecting an external matching pad to the RF input.

Amplitude settings for input from the optional "Analog Baseband" interface are described in the FSW I/Q Analyzer and I/Q Input User Manual.

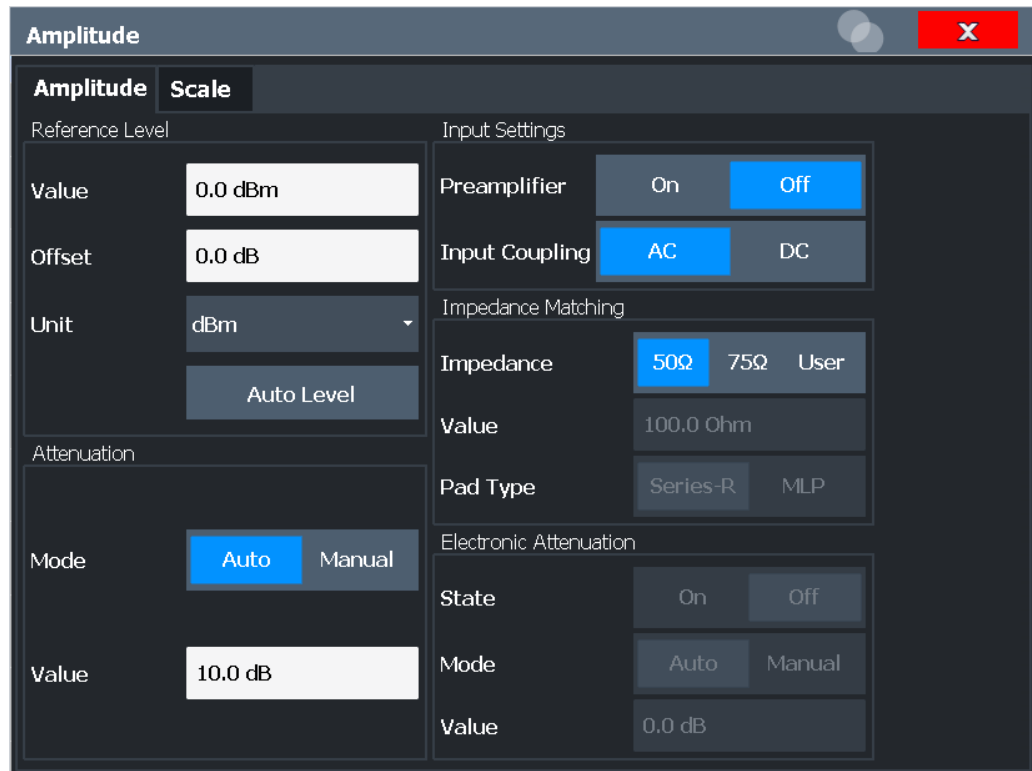

Reference Level.....	75
L Shifting the Display (Offset).....	76
L Unit.....	76
L Setting the Reference Level Automatically (Auto Level).....	76
Attenuation Mode / Value.....	76
Using Electronic Attenuation.....	77
Input Settings.....	77
L Preamplifier.....	78
L Ext. PA Correction.....	78

Reference Level

Defines the expected maximum reference level. Signal levels above this value are possibly not measured correctly. Signals above the reference level are indicated by an "IF Overload" or "OVLd" status display.

The reference level can also be used to scale power diagrams; the reference level is then used for the calculation of the maximum on the y-axis.

Since the hardware of the FSW is adapted according to this value, it is recommended that you set the reference level close above the expected maximum signal level. Thus you ensure an optimal measurement (no compression, good signal-to-noise ratio).

Remote command:

```
DISPlay[:WINDow<n>] [:SUBWindow<w>]:TRACe<t>:Y[:SCALE]:RLEVEL
```

on page 190

Shifting the Display (Offset) ← Reference Level

Defines an arithmetic level offset. This offset is added to the measured level. In some result displays, the scaling of the y-axis is changed accordingly.

Define an offset if the signal is attenuated or amplified before it is fed into the FSW so the application shows correct power results. All displayed power level results are shifted by this value.

The setting range is ± 200 dB in 0.01 dB steps.

Note, however, that the *internal* reference level (used to adjust the hardware settings to the expected signal) ignores any "Reference Level Offset". Thus, it is important to keep in mind the actual power level the FSW must handle. Do not rely on the displayed reference level (internal reference level = displayed reference level - offset).

Remote command:

`DISPlay[:WINDow<n>][:SUBWindow<w>]:TRACe<t>:Y[:SCALe]:RLEVel:OFFSet` on page 191

Unit ← Reference Level

For CDA measurements, do not change the unit, as it would lead to useless results.

Setting the Reference Level Automatically (Auto Level) ← Reference Level

Automatically determines a reference level which ensures that no overload occurs at the FSW for the current input data. At the same time, the internal attenuators and the preamplifier (for analog baseband input: the full-scale level) are adjusted. As a result, the signal-to-noise ratio is optimized, while signal compression and clipping are minimized.

To determine the required reference level, a level measurement is performed on the FSW.

If necessary, you can optimize the reference level further. Decrease the attenuation level manually to the lowest possible value before an overload occurs, then decrease the reference level in the same way.

You can change the measurement time for the level measurement if necessary (see "[Changing the Automatic Measurement Time \(Meas Time Manual\)](#)" on page 101).

Remote command:

`[SENSe:]ADJust:LEVel` on page 222

Attenuation Mode / Value

Defines the attenuation applied to the RF input of the FSW.

This function is not available for input from the optional "Digital Baseband" interface.

The RF attenuation can be set automatically as a function of the selected reference level (Auto mode). Automatic attenuation ensures that no overload occurs at the RF Input connector for the current reference level. It is the default setting.

By default and when no (optional) [electronic attenuation](#) is available, mechanical attenuation is applied.

This function is not available for input from the optional "**Digital Baseband**" interface.

In "Manual" mode, you can set the RF attenuation in 1 dB steps (down to 0 dB). Other entries are rounded to the next integer value. The range is specified in the specifications document. If the defined reference level cannot be set for the defined RF attenuation, the reference level is adjusted accordingly and the warning "limit reached" is displayed.

NOTICE! Risk of hardware damage due to high power levels. When decreasing the attenuation manually, ensure that the power level does not exceed the maximum level allowed at the RF input, as an overload can lead to hardware damage.

Remote command:

[INPut:ATTenuation](#) on page 194

[INPut:ATTenuation:AUTO](#) on page 194

Using Electronic Attenuation

If the (optional) Electronic Attenuation hardware is installed on the FSW, you can also activate an electronic attenuator.

In "Auto" mode, the settings are defined automatically; in "Manual" mode, you can define the mechanical and electronic attenuation separately.

This function is not available for input from the optional "Digital Baseband" interface.

Note: Electronic attenuation is not available for stop frequencies (or center frequencies in zero span) above 15 GHz.

In "Auto" mode, RF attenuation is provided by the electronic attenuator as much as possible to reduce the amount of mechanical switching required. Mechanical attenuation can provide a better signal-to-noise ratio, however.

When you switch off electronic attenuation, the RF attenuation is automatically set to the same mode (auto/manual) as the electronic attenuation was set to. Thus, the RF attenuation can be set to automatic mode, and the full attenuation is provided by the mechanical attenuator, if possible.

The electronic attenuation can be varied in 1 dB steps. If the electronic attenuation is on, the mechanical attenuation can be varied in 5 dB steps. Other entries are rounded to the next lower integer value.

For the FSW85, the mechanical attenuation can be varied only in 10 dB steps.

If the defined reference level cannot be set for the given attenuation, the reference level is adjusted accordingly and the warning "limit reached" is displayed in the status bar.

Remote command:

[INPut:EATT:STATE](#) on page 195

[INPut:EATT:AUTO](#) on page 195

[INPut:EATT](#) on page 194

Input Settings

Some input settings affect the measured amplitude of the signal, as well.

The parameters "Input Coupling" and "Impedance" are identical to those in the "Input" settings.

Preamplifier ← Input Settings

If the (optional) internal preamplifier hardware is installed on the FSW, a preamplifier can be activated for the RF input signal.

You can use a preamplifier to analyze signals from DUTs with low output power.

Note: If an optional external preamplifier is activated, the internal preamplifier is automatically disabled, and vice versa.

This function is not available for input from the (optional) "Digital Baseband" interface.

For all FSW models except for FSW85, the following settings are available:

"Off"	Deactivates the preamplifier.
"15 dB"	The RF input signal is amplified by about 15 dB.
"30 dB"	The RF input signal is amplified by about 30 dB.

For older FSW43/FSW50/FSW67 models, the input signal is always amplified by about 30 dB when the preamplifier is active.

For FSW85 models, no preamplifier is available.

Remote command:

[INPut:GAIN:STATe](#) on page 192

[INPut:GAIN\[:VALue\]](#) on page 193

Ext. PA Correction ← Input Settings

This function is only available if an external preamplifier is connected to the FSW, and only for frequencies above 1 GHz. For details on connection, see the preamplifier's documentation.

Using an external preamplifier, you can measure signals from devices under test with low output power, using measurement devices which feature a low sensitivity and do not have a built-in RF preamplifier.

When you connect the external preamplifier, the FSW reads out the touchdown (.S2P) file from the EEPROM of the preamplifier. This file contains the s-parameters of the preamplifier. As soon as you connect the preamplifier to the FSW, the preamplifier is permanently on and ready to use. However, you must enable data correction based on the stored data explicitly on the FSW using this setting.

When enabled, the FSW automatically compensates the magnitude and phase characteristics of the external preamplifier in the measurement results. Any internal preamplifier, if available, is disabled.

For FSW85 models with two RF inputs, you can enable correction from the external preamplifier for each input individually, but not for both at the same time.

When disabled, no compensation is performed even if an external preamplifier remains connected.

Remote command:

[INPut:EGAIN\[:STATe\]](#) on page 192

5.2.4.2 Y-axis scaling

Access: "Overview" > "Input/Frontend" > "Scale"

Or: [AMPT] > "Scale Config"

The vertical axis scaling is configurable. In Code Domain Analysis, the y-axis usually displays the measured power levels.

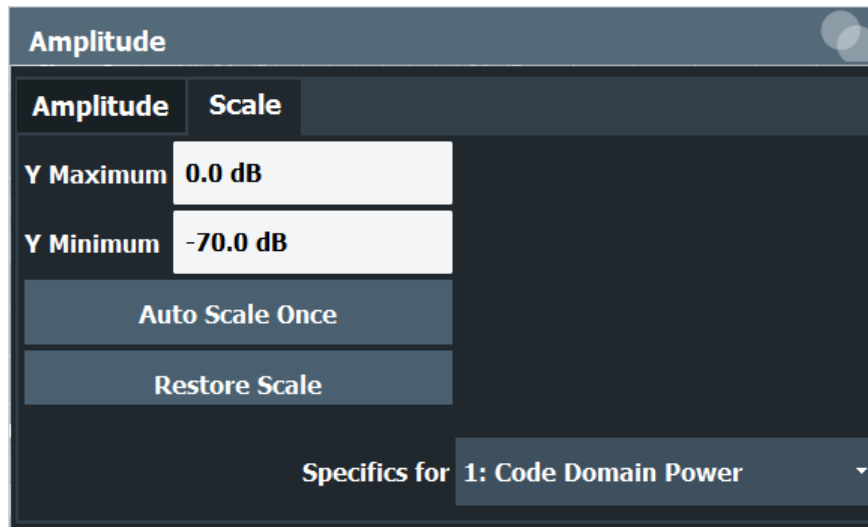

Y-Maximum, Y-Minimum.....	79
Auto Scale Once.....	79
Restore Scale (Window).....	79

Y-Maximum, Y-Minimum

Defines the amplitude range to be displayed on the y-axis of the evaluation diagrams.

Remote command:

`DISPlay[:WINDow<n>]:TRACe<t>:Y[:SCALE]:MAXimum` on page 191

`DISPlay[:WINDow<n>]:TRACe<t>:Y[:SCALE]:MINimum` on page 191

Auto Scale Once

Automatically determines the optimal range and reference level position to be displayed for the current measurement settings.

The display is only set once; it is not adapted further if the measurement settings are changed again.

Remote command:

`DISPlay[:WINDow<n>][:SUBWindow<w>]:TRACe<t>:Y[:SCALE]:AUTO ONCE`
on page 190

Restore Scale (Window)

Restores the default scale settings in the currently selected window.

5.2.4.3 Frequency settings

Access: "Overview" > "Input/Frontend" > "Frequency"

Center Frequency.....	80
Center Frequency Stepsize.....	80
Frequency Offset.....	81

Center Frequency

Defines the center frequency of the signal in Hertz.

The allowed range of values for the center frequency depends on the frequency span.

$$\text{span} > 0: \text{span}_{\min}/2 \leq f_{\text{center}} \leq f_{\text{max}} - \text{span}_{\min}/2$$

f_{max} and span_{\min} depend on the instrument and are specified in the specifications document.

Remote command:

[\[SENSe:\] FREQuency:CENTer](#) on page 187

Center Frequency Stepsize

Defines the step size by which the center frequency is increased or decreased using the arrow keys.

When you use the rotary knob the center frequency changes in steps of only 1/10 of the span.

The step size can be coupled to another value or it can be manually set to a fixed value.

This setting is available for frequency and time domain measurements.

- | | |
|------------|--|
| "X * Span" | Sets the step size for the center frequency to a defined factor of the span. The "X-Factor" defines the percentage of the span. Values between 1 % and 100 % in steps of 1 % are allowed. The default setting is 10 %. |
| "= Center" | Sets the step size to the value of the center frequency. The used value is indicated in the "Value" field. |
| "Manual" | Defines a fixed step size for the center frequency. Enter the step size in the "Value" field. |

Remote command:

[\[SENSe:\] FREQuency:CENTer:STEP](#) on page 188

Frequency Offset

Shifts the displayed frequency range along the x-axis by the defined offset.

This parameter has no effect on the instrument's hardware, on the captured data, or on data processing. It is simply a manipulation of the final results in which absolute frequency values are displayed. Thus, the x-axis of a spectrum display is shifted by a constant offset if it shows absolute frequencies. However, if it shows frequencies relative to the signal's center frequency, it is not shifted.

A frequency offset can be used to correct the display of a signal that is slightly distorted by the measurement setup, for example.

The allowed values range from -1 THz to 1 THz. The default setting is 0 Hz.

Note: In MSRA mode, this function is only available for the MSRA primary.

Remote command:

[SENSe:] FREQuency:OFFSet on page 188

5.2.5 Trigger settings

Access: "Overview" > "Trigger"

Trigger settings determine when the input signal is measured.

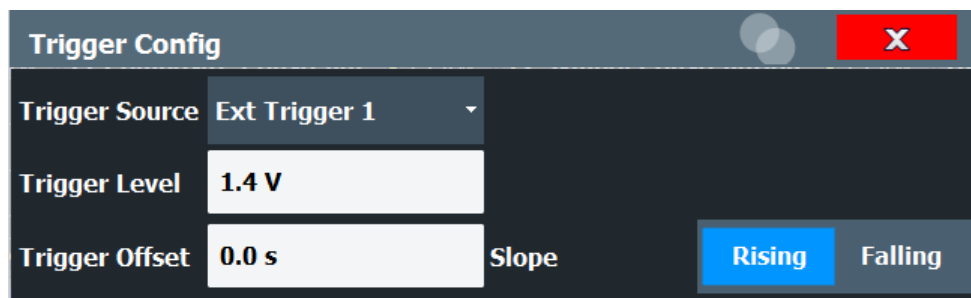

External triggers from one of the [TRIGGER INPUT/OUTPUT] connectors on the FSW are configured in a separate tab of the dialog box.

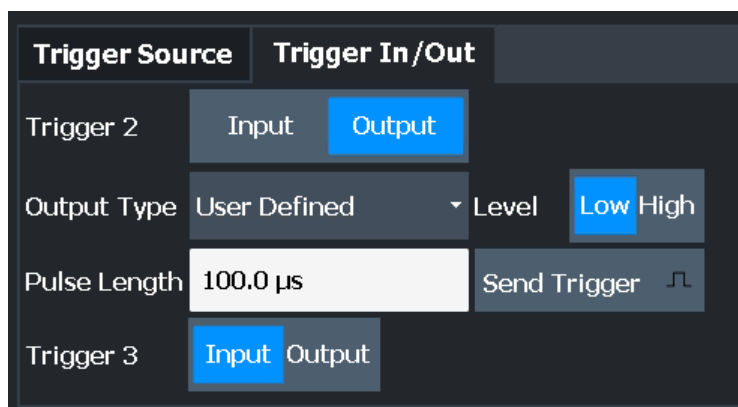

For step-by-step instructions on configuring triggered measurements, see the main FSW User Manual.

Trigger Source.....	82
L Trigger Source.....	82
L Free Run.....	82
L External Trigger 1/2/3.....	82
L Digital I/Q.....	83
L IF Power.....	83
L Trigger Level.....	84
L Trigger Offset.....	84
L Slope.....	84
L Capture Offset.....	84
Trigger 2/3.....	85
L Output Type.....	85
L Level.....	86
L Pulse Length.....	86
L Send Trigger.....	86

Trigger Source

The trigger settings define the beginning of a measurement.

Trigger Source ← Trigger Source

Defines the trigger source. If a trigger source other than "Free Run" is set, "TRG" is displayed in the channel bar and the trigger source is indicated.

Remote command:

`TRIGger [:SEquence] :SOURce` on page 199

Free Run ← Trigger Source ← Trigger Source

No trigger source is considered. Data acquisition is started manually or automatically and continues until stopped explicitly.

Remote command:

`TRIG:SOUR IMM`, see `TRIGger [:SEquence] :SOURce` on page 199

External Trigger 1/2/3 ← Trigger Source ← Trigger Source

Data acquisition starts when the TTL signal fed into the specified input connector meets or exceeds the specified trigger level.

(See "Trigger Level" on page 84).

Note: "External Trigger 1" automatically selects the trigger signal from the "TRIGGER 1 INPUT" connector on the front panel.

For details, see the "Instrument Tour" chapter in the FSW Getting Started manual.

"External Trigger 1"

Trigger signal from the "TRIGGER 1 INPUT" connector.

"External Trigger 2"

Trigger signal from the "TRIGGER 2 INPUT / OUTPUT" connector.

Note: Connector must be configured for "Input" in the "Output" configuration

For FSW85 models, "Trigger 2" is not available due to the second RF input connector on the front panel.

(See the FSW base unit user manual).

"External Trigger 3"

Trigger signal from the "TRIGGER 3 INPUT / OUTPUT" connector on the rear panel.

Note: Connector must be configured for "Input" in the "Output" configuration.

(See FSW base unit user manual).

Remote command:

TRIG:SOUR EXT, TRIG:SOUR EXT2

TRIG:SOUR EXT3

See [TRIGger\[:SEquence\]:SOURce](#) on page 199

Digital I/Q ← Trigger Source ← Trigger Source

For applications that process I/Q data, such as the I/Q Analyzer or optional applications, and only if the optional "Digital Baseband" interface is available:

Defines triggering of the measurement directly via the "LVDS" connector. In the selection list, specify which general-purpose bit ("GP0" to "GP5") provides the trigger data.

Note: If the Digital I/Q enhanced mode is used, i.e. the connected device supports transfer rates up to 200 Msps, only the general-purpose bits "GP0" and "GP1" are available as a Digital I/Q trigger source.

The following table describes the assignment of the general-purpose bits to the LVDS connector pins.

(For details on the LVDS connector, see the FSW I/Q Analyzer User Manual.)

Table 5-1: Assignment of general-purpose bits to LVDS connector pins

Bit	LVDS pin
GP0	SDATA4_P - Trigger1
GP1	SDATA4_P - Trigger2
GP2 *)	SDATA0_P - Reserve1
GP3 *)	SDATA4_P - Reserve2
GP4 *)	SDATA0_P - Marker1
GP5 *)	SDATA4_P - Marker2
*): not available for Digital I/Q enhanced mode	

Remote command:

TRIG:SOUR GP0, see [TRIGger\[:SEquence\]:SOURce](#) on page 199

IF Power ← Trigger Source ← Trigger Source

The FSW starts capturing data as soon as the trigger level is exceeded around the third intermediate frequency.

For frequency sweeps, the third IF represents the start frequency. The trigger threshold depends on the defined trigger level, as well as on the RF attenuation and preamplification. A reference level offset, if defined, is also considered. The trigger bandwidth at the intermediate frequency depends on the RBW and sweep type. For details on available trigger levels and trigger bandwidths, see the instrument specifications document.

For measurements on a fixed frequency (e.g. zero span or I/Q measurements), the third IF represents the center frequency.

This trigger source is only available for RF input.

This trigger source is available for frequency and time domain measurements only.

Available for input from the optional "Analog Baseband" interface.

Available for input from the optional "Digital Baseband" interface.

The available trigger levels depend on the RF attenuation and preamplification. A reference level offset, if defined, is also considered.

For details on available trigger levels and trigger bandwidths, see the specifications document.

Remote command:

TRIG:SOUR IFP, see TRIGger[:SEquence]:SOURce on page 199

Trigger Level ← Trigger Source

Defines the trigger level for the specified trigger source.

For details on supported trigger levels, see the instrument specifications document.

Remote command:

TRIGger[:SEquence]:LEVel[:EXTernal<port>] on page 198

For baseband input only:

TRIGger[:SEquence]:LEVel:BBPower on page 197

Trigger Offset ← Trigger Source

Defines the time offset between the trigger event and the start of the measurement.

Offset > 0:	Start of the measurement is delayed
Offset < 0:	Measurement starts earlier (pretrigger)

Remote command:

TRIGger[:SEquence]:HOLDoff[:TIME] on page 196

Slope ← Trigger Source

For all trigger sources except time, you can define whether triggering occurs when the signal rises to the trigger level or falls down to it.

Remote command:

TRIGger[:SEquence]:SLOPe on page 199

Capture Offset ← Trigger Source

This setting is only available for secondary applications in **MSRA operating mode**. It has a similar effect as the trigger offset in other measurements: it defines the time offset between the capture buffer start and the start of the extracted secondary application data.

In MSRA mode, the offset must be a positive value, as the capture buffer starts at the trigger time = 0.

For details on the MSRA operating mode, see the [R&S®FSW MSRA Mode User Manual](#).

Remote command:

[\[SENSe:\]MSRA:CAPTure:OFFSet](#) on page 288

Trigger 2/3

The trigger input and output functionality depends on how the variable "Trigger Input/Output" connectors are used.

Note: Providing trigger signals as output is described in detail in the FSW base unit user manual.

"Trigger 1"	"Trigger 1" is input only.
"Trigger 2"	Defines the usage of the variable "Trigger Input/Output" connector on the front panel (not available for FSW85 models with 2 RF input connectors)
"Trigger 3"	Defines the usage of the variable "Trigger 3 Input/Output" connector on the rear panel
"Input"	The signal at the connector is used as an external trigger source by the FSW. Trigger input parameters are available in the "Trigger" dialog box.
"Output"	The FSW sends a trigger signal to the output connector to be used by connected devices. Further trigger parameters are available for the connector.

Remote command:

[OUTPut:TRIGger<tp>:DIRection](#) on page 201

Output Type ← Trigger 2/3

Type of signal to be sent to the output

"Device Triggered" (Default) Sends a trigger when the FSW triggers.

- "Trigger Armed" Sends a (high level) trigger when the FSW is in "Ready for trigger" state.
This state is indicated by a status bit in the `STATUS:OPERation` register (bit 5), as well as by a low-level signal at the "AUX" port (pin 9).
- "User Defined" Sends a trigger when you select "Send Trigger".
In this case, further parameters are available for the output signal.

Remote command:

`OUTPut:TRIGger<tp>:OTYPe` on page 202

Level ← Output Type ← Trigger 2/3

Defines whether a high (1) or low (0) constant signal is sent to the trigger output connector (for "Output Type": "User Defined").

The trigger pulse level is always opposite to the constant signal level defined here. For example, for "Level" = "High", a constant high signal is output to the connector until you select the [Send Trigger](#) function. Then, a low pulse is provided.

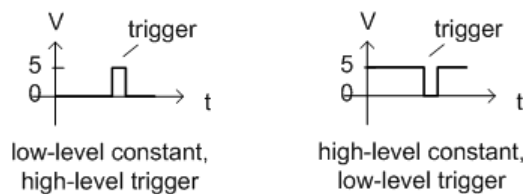

Remote command:

`OUTPut:TRIGger<tp>:LEVel` on page 201

Pulse Length ← Output Type ← Trigger 2/3

Defines the duration of the pulse (pulse width) sent as a trigger to the output connector.

Remote command:

`OUTPut:TRIGger<tp>:PULSe:LENGth` on page 203

Send Trigger ← Output Type ← Trigger 2/3

Sends a user-defined trigger to the output connector immediately.

Note that the trigger pulse level is always opposite to the constant signal level defined by the output [Level](#) setting. For example, for "Level" = "High", a constant high signal is output to the connector until you select the "Send Trigger" function. Then, a low pulse is sent.

Which pulse level is sent is indicated by a graphic on the button.

Remote command:

`OUTPut:TRIGger<tp>:PULSe:IMMediate` on page 202

5.2.6 Signal capture (data acquisition)

Access: "Overview" > "Signal Capture"

or: [MEAS CONFIG] > "Signal Capture"

How much and how data is captured from the input signal are defined in the "Signal Capture" settings.

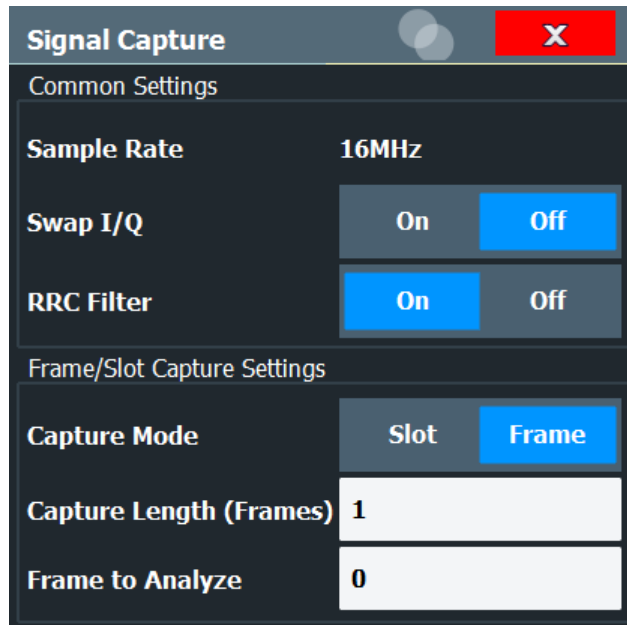

MSRA operating mode

In MSRA operating mode, only the MSRA primary channel actually captures data from the input signal. The data acquisition settings for the 3GPP FDD BTS application in MSRA mode define the **application data extract**. See [Chapter 5.2.7, "Application data \(MSRA\)"](#), on page 89.

For details on the MSRA operating mode see the FSW MSRA User Manual.

Sample Rate.....	87
Swap I/Q.....	87
RRC Filter State.....	88
Capture Mode.....	88
Capture Length (Frames).....	88
Capture Offset.....	88
Frame To Analyze.....	88
Capture Time.....	89

Sample Rate

The sample rate is always 16 MHz (indicated for reference only).

Swap I/Q

Activates or deactivates the inverted I/Q modulation. If the I and Q parts of the signal from the DUT are interchanged, the FSW can do the same to compensate for it.

On	I and Q signals are interchanged Inverted sideband, $Q+j*I$
Off	I and Q signals are not interchanged Normal sideband, $I+j*Q$

Remote command:

[\[SENSe:\] SWAPiQ](#) on page 205

RRC Filter State

Selects if a root raised cosine (RRC) receiver filter is used or not. This feature is useful if the RRC filter is implemented in the device under test (DUT).

- | | |
|-------|---|
| "ON" | If an unfiltered signal is received (normal case), the RRC filter should be used to get a correct signal demodulation. (Default settings) |
| "OFF" | If a filtered signal is received, the RRC filter should not be used to get a correct signal demodulation. This is the case if the DUT filters the signal. |

Remote command:

[\[SENSe:\] CDPower: FILTer \[: STATE\]](#) on page 204

Capture Mode

Captures a single slot or one complete frame.

Remote command:

[\[SENSe:\] CDPower: BASE](#) on page 204

Capture Length (Frames)

Defines the capture length (amount of frames to record).

Note: if this setting is not available, [Capture Mode](#) is set to "Slot", i.e. only one slot is captured.

Remote command:

[\[SENSe:\] CDPower: IQLength](#) on page 204

Capture Offset

This setting is only available for secondary applications in **MSRA operating mode**. It has a similar effect as the trigger offset in other measurements: it defines the time offset between the capture buffer start and the start of the extracted secondary application data.

In MSRA mode, the offset must be a positive value, as the capture buffer starts at the trigger time = 0.

For details on the MSRA operating mode, see the [R&S®FSW MSRA Mode User Manual](#).

Remote command:

[\[SENSe:\] MSRA: CAPTure: OFFSet](#) on page 288

Frame To Analyze

Defines the frame to be analyzed and displayed.

Note: if this setting is not available in UE tests, [Capture Mode](#) is set to "Slot", i.e. only one slot is captured.

Remote command:

[\[SENSe:\] CDPower: FRAME \[: VALue\]](#) on page 223

Capture Time

This setting is read-only.

It indicates the capture time determined by the capture length and sample rate.

5.2.7 Application data (MSRA)

For the 3GPP FDD BTS application in MSRA operating mode, the application data range is defined by the same settings used to define the signal capturing in Signal and Spectrum Analyzer mode (see [Chapter 5.2.6, "Signal capture \(data acquisition\)"](#), on page 86).

In addition, a capture offset can be defined, i.e. an offset from the start of the captured data to the start of the analysis interval for the 3GPP FDD BTS measurement (see ["Capture Offset"](#) on page 84).

The **analysis interval** cannot be edited manually, but is determined automatically according to the selected channel, slot or frame to analyze which is defined for the evaluation range, depending on the result display. Note that the frame/slot/channel is analyzed *within the application data*.

5.2.8 Synchronization (BTS measurements only)

Access: "Overview" > "Synchronization" > "Antenna1"/"Antenna2"

or: [MEAS CONFIG] > "Sync"

For BTS tests, the individual channels in the input signal need to be synchronized to detect timing offsets in the slot spacings. These settings are described here.

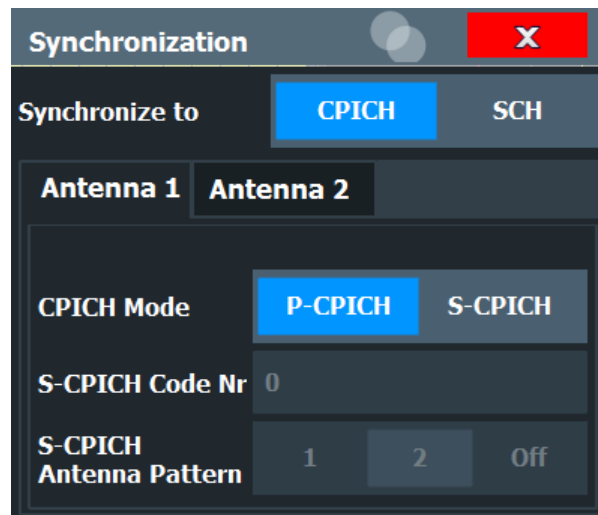

Synchronization Type.....	90
Antenna1 / Antenna2.....	90
L CPICH Mode.....	90
L S-CPICH Code Nr.....	90
S-CPICH Antenna Pattern.....	90

Synchronization Type

Defines whether the signal is synchronized to the CPICH or the synchronization channel (SCH).

"CPICH"	The 3GPP FDD application assumes that the CPICH control channel is present in the signal and attempts to synchronize to this channel. If the signal does not contain CPICH, synchronization fails.
"SCH"	The 3GPP FDD application synchronizes to the signal without assuming the presence of a CPICH. This setting is required for measurements on test model 4 without CPICH. While this setting can also be used with other channel configurations, it should be noted that the probability of synchronization failure increases with the number of data channels.

Remote command:

[\[SENSe:\]CDPower:STYPe](#) on page 206

Antenna1 / Antenna2

Synchronization is configured for each diversity antenna individually, on separate tabs.

The 3GPP FDD standard defines two different CPICH patterns for diversity antenna 1 and antenna 2. The CPICH pattern used for synchronization can be defined depending on the antenna (standard configuration), or fixed to either pattern, independently of the antenna (user-defined configuration).

Remote command:

[\[SENSe:\]CDPower:ANTenna](#) on page 161

CPICH Mode ← Antenna1 / Antenna2

Defines whether the common pilot channel (CPICH) is defined by its default position or a user-defined position.

"P-CPICH"	Standard configuration (CPICH is always on channel 0)
"S-CPICH"	User-defined configuration. Enter the CPICH code number in the S-CPICH Code Nr field.

Remote command:

[\[SENSe:\]CDPower:UCPich:ANTenna<antenna>\[:STATe\]](#) on page 293

S-CPICH Code Nr ← Antenna1 / Antenna2

If a user-defined CPICH definition is to be used, enter the code of the CPICH based on the spreading factor 256. Possible values are 0 to 255.

Remote command:

[\[SENSe:\]CDPower:UCPich:ANTenna<antenna>:CODE](#) on page 205

S-CPICH Antenna Pattern

Defines the pattern used for evaluation.

Remote command:

[\[SENSe:\]CDPower:UCPich:ANTenna<antenna>:PATTern](#) on page 293

5.2.9 Channel detection

Access: "Overview" > "Channel Detection"

or: [MEAS CONFIG] > "Channel Detection"

The channel detection settings determine which channels are found in the input signal.

- [General channel detection settings](#).....91
- [Channel table management](#).....93
- [Channel table settings and functions](#).....95
- [Channel details](#).....96

5.2.9.1 General channel detection settings

Access: "Overview" > "Channel Detection"

or: [MEAS CONFIG] > "Channel Detection"

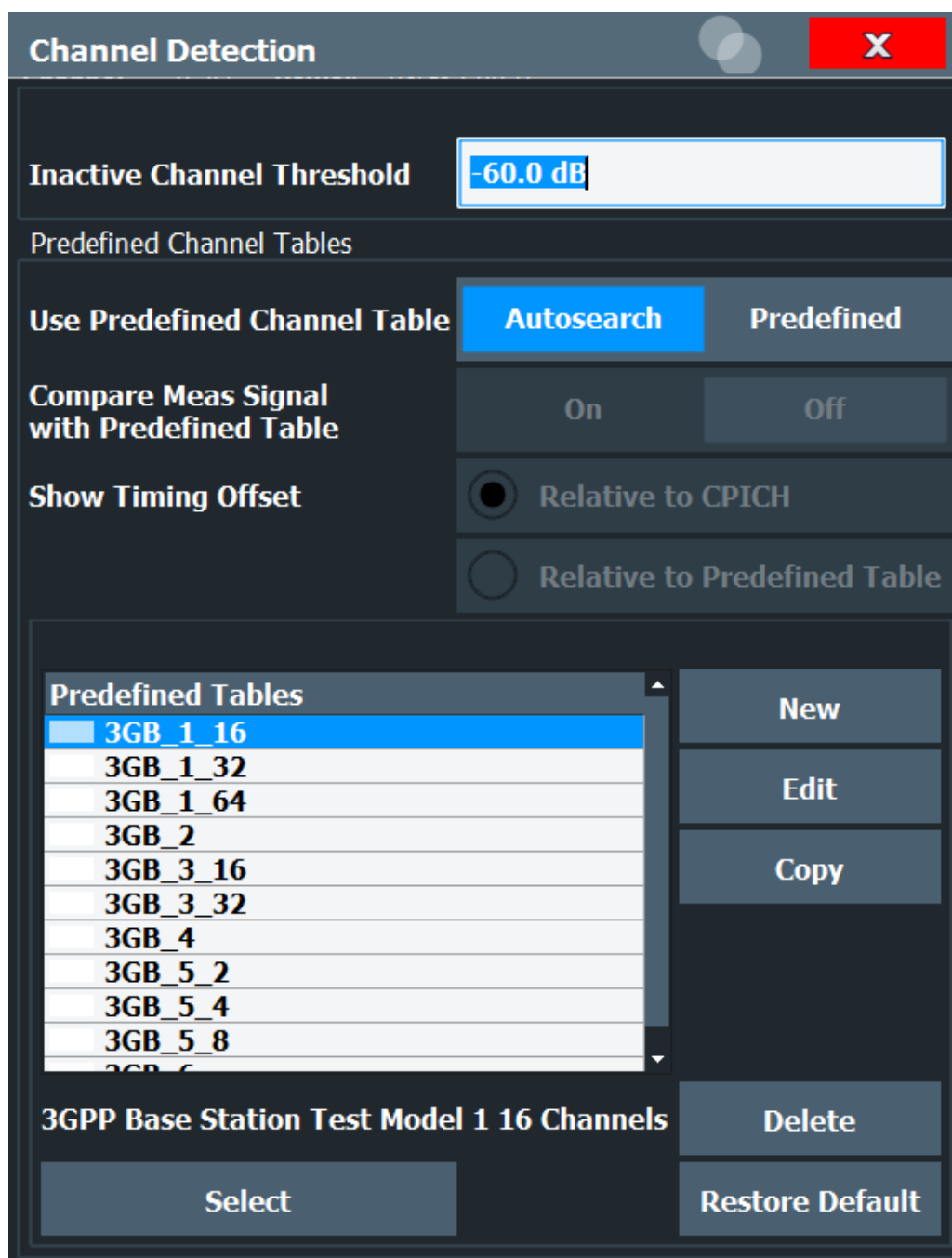

Inactive Channel Threshold (BTS measurements only).....	92
Using Predefined Channel Tables.....	93
Comparing the Measurement Signal with the Predefined Channel Table.....	93
Timing Offset Reference.....	93

Inactive Channel Threshold (BTS measurements only)

Defines the minimum power that a single channel must have compared to the total signal in order to be recognized as an active channel.

Remote command:

[\[SENSe:\]CDPower:ICTReshold](#) on page 209

Using Predefined Channel Tables

Defines the channel search mode.

"Predefined" Compares the input signal to the predefined channel table selected in the "Predefined Tables" list

"Autosearch" Detects channels automatically using pilot sequences

Remote command:

BTS measurements:

[CONFigure:WCDPower\[:BTS\]:CTABLE\[:STATe\]](#) on page 209

UE measurements:

[CONFigure:WCDPower:MS:CTABLE\[:STATe\]](#) on page 211

Comparing the Measurement Signal with the Predefined Channel Table

If enabled, the 3GPP FDD application compares the measured signal to the predefined channel tables. In the result summary, only the differences to the predefined table settings are displayed.

Remote command:

[CONFigure:WCDPower\[:BTS\]:CTABLE:COMPare](#) on page 208

Timing Offset Reference

Defines the reference for the timing offset of the displayed measured signal.

"Relative to CPICH" The measured timing offset is shown in relation to the CPICH.

"Relative to Predefined Table" If the predefined table contains timing offsets, the delta between the defined and measured offsets are displayed in the evaluations.

Remote command:

[CONFigure:WCDPower:MS:CTABLE:TOFFset](#) on page 208

5.2.9.2 Channel table management

Access: "Overview" > "Channel Detection"

Predefined Tables	93
Selecting a Table	94
Creating a New Table	94
Editing a Table	94
Copying a Table	94
Deleting a Table	94
Restoring Default Tables	94

Predefined Tables

The list shows all available channel tables and marks the currently used table with a checkmark. The currently *focussed* table is highlighted blue.

Remote command:

BTS measurements:

[CONFigure:WCDPower\[:BTS\]:CTABLE:CATalog](#) on page 209

UE measurements:

[CONFigure:WCDPower:MS:CTABLE:CATalog](#) on page 212

Selecting a Table

Selects the channel table currently focused in the "Predefined Tables" list and compares it to the measured signal to detect channels.

Remote command:

BTS measurements:

[CONFigure:WCDPower\[:BTS\]:CTABLE:SElect](#) on page 211

UE measurements:

[CONFigure:WCDPower:MS:CTABLE:SElect](#) on page 213

Creating a New Table

Creates a new channel table. See [Chapter 5.2.9.4, "Channel details"](#), on page 96.

For step-by-step instructions on creating a new channel table, see ["To define or edit a channel table"](#) on page 133.

Editing a Table

You can edit existing channel table definitions. The details of the selected channel are displayed in the "Channel Table" dialog box. See [Chapter 5.2.9.4, "Channel details"](#), on page 96.

Copying a Table

Copies an existing channel table definition. The details of the selected channel are displayed in the "Channel Table" dialog box. See [Chapter 5.2.9.4, "Channel details"](#), on page 96.

Remote command:

BTS measurements:

[CONFigure:WCDPower\[:BTS\]:CTABLE:COpy](#) on page 210

UE measurements:

[CONFigure:WCDPower:MS:CTABLE:COpy](#) on page 212

Deleting a Table

Deletes the currently selected channel table after a message is confirmed.

Remote command:

BTS measurements:

[CONFigure:WCDPower\[:BTS\]:CTABLE:DElete](#) on page 211

UE measurements:

[CONFigure:WCDPower:MS:CTABLE:DElete](#) on page 212

Restoring Default Tables

Restores the predefined channel tables delivered with the instrument.

5.2.9.3 Channel table settings and functions

Access: "Overview" > "Channel Detection" > "New"/"Copy"/"Edit"

or: [MEAS CONFIG] > "Channel Detection" > "New"/"Copy"/"Edit"

Some general settings and functions are available when configuring a predefined channel table.

Name.....	95
Comment.....	95
Adding a Channel.....	95
Deleting a Channel.....	95
Creating a New Channel Table from the Measured Signal (Measure Table).....	95
Sorting the Table.....	96
Cancelling Configuration.....	96
Saving the Table.....	96

Name

Name of the channel table that will be displayed in the "Predefined Channel Tables" list.

Remote command:

BTS measurements:

[CONFigure:WCDPower\[:BTS\]:CTABLE:NAME](#) on page 214

UE measurements:

[CONFigure:WCDPower:MS:CTABLE:NAME](#) on page 214

Comment

Optional description of the channel table.

Remote command:

BTS measurements:

[CONFigure:WCDPower\[:BTS\]:CTABLE:COMMENT](#) on page 213

UE measurements:

[CONFigure:WCDPower:MS:CTABLE:COMMENT](#) on page 214

Adding a Channel

Inserts a new row in the channel table to define another channel.

Deleting a Channel

Deletes the currently selected channel from the table.

Creating a New Channel Table from the Measured Signal (Measure Table)

Creates a completely new channel table according to the current measurement data.

Remote command:

BTS measurements:

[CONFigure:WCDPower\[:BTS\]:CTABLE:MTABLE](#) on page 214

UE measurements:

[CONFigure:WCDPower:MS:CTABLE:MTABLE](#) on page 215

Sorting the Table

Sorts the channel table entries.

Cancelling Configuration

Closes the "Channel Table" dialog box without saving the changes.

Saving the Table

Saves the changes to the table and closes the "Channel Table" dialog box.

5.2.9.4 Channel details

Access: "Overview" > "Channel Detection" > "New"/"Copy"/"Edit"

or: [MEAS CONFIG] > "Channel Detection" > "New"/"Copy"/"Edit"

The screenshot shows the 'Channel Detection' dialog box with the following details:

- Title:** Channel Detection
- Channel Table Setting:**
 - Name: My Table
 - Comment: Test Table
- Buttons:** Add Channel, Delete Channel, Measure Table, Sort Table, Cancel, Save Table
- Table:**

Channel Type	Symbol Rate	Channel Number	Use TFCI	Timing Offset	Pilot Bits	CDP Relative	State	Conflict
CPICH	---	0	---	---	---	0.000	On	
PCCPCH	15	1	---	---	---	0.000	On	
SCCPCH	15	3	---	0	0	0.000	On	
PICH	---	16	---	30720	---	0.000	On	
DPCH	30	2	Off	22016	8	0.000	On	
DPCH	30	11	Off	34304	8	0.000	On	
DPCH	30	17	Off	13312	8	0.000	On	
DPCH	30	23	Off	11520	8	0.000	On	
DPCH	30	31	Off	36608	8	0.000	On	
DPCH	30	38	On	28672	8	0.000	On	
DPCH	30	47	Off	15104	8	0.000	On	
DPCH	30	55	Off	5888	8	0.000	On	
DPCH	30	62	Off	256	8	0.000	On	
DPCH	30	69	Off	22528	8	0.000	On	
DPCH	30	78	Off	7680	8	0.000	On	
DPCH	30	85	Off	4608	8	0.000	On	
DPCH	30	94	Off	7680	8	0.000	On	
DPCH	30	102	Off	15616	8	0.000	On	

Channel Type..... 97

Symbol Rate..... 97

Channel Number (Ch. SF)..... 97

Use TFCI..... 97

Mapping (UE only)..... 97

Timing Offset..... 97

Pilot Bits..... 97

CDP Relative..... 97

State..... 98

Conflict..... 98

Channel Type

Type of channel. For a list of possible channel types see [Chapter 4.2, "BTS channel types"](#), on page 45.

Remote command:

BTS measurements:

[CONFigure:WCDPower\[:BTS\]:CTABLE:DATA](#) on page 215

UE measurements:

[CONFigure:WCDPower:MS:CTABLE:DATA](#) on page 216

Symbol Rate

Symbol rate at which the channel is transmitted.

Channel Number (Ch. SF)

Number of channel spreading code (0 to [spreading factor-1])

Remote command:

BTS measurements:

[CONFigure:WCDPower\[:BTS\]:CTABLE:DATA](#) on page 215

UE measurements:

[CONFigure:WCDPower:MS:CTABLE:DATA](#) on page 216

Use TFCI

Indicates whether the slot format and data rate are determined by the Transport Format Combination Indicator(TFCI).

This function is available in BTS mode only.

Remote command:

[CONFigure:WCDPower\[:BTS\]:CTABLE:DATA](#) on page 215

Mapping (UE only)

Branch onto which the channel is mapped (I or Q). The setting is not editable, since the standard specifies the channel assignment for each channel.

Timing Offset

Defines a timing offset in relation to the CPICH channel. During evaluation, the detected timing offset can be compared to this setting; only the delta is displayed (see "[Timing Offset Reference](#)" on page 93).

Remote command:

[CONFigure:WCDPower\[:BTS\]:CTABLE:DATA](#) on page 215

Pilot Bits

Number of pilot bits of the channel (only valid for the control channel DPCCH)

Remote command:

BTS measurements:

[CONFigure:WCDPower\[:BTS\]:CTABLE:DATA](#) on page 215

UE measurements:

[CONFigure:WCDPower:MS:CTABLE:DATA](#) on page 216

CDP Relative

Code domain power (relative to the total power of the signal)

Remote command:

BTS measurements:

[CONFigure:WCDPower\[:BTS\]:CTABLE:DATA](#) on page 215

UE measurements:

[CONFigure:WCDPower:MS:CTABLE:DATA](#) on page 216

State

Indicates the channel state. Codes that are not assigned are marked as inactive channels.

Remote command:

BTS measurements:

[CONFigure:WCDPower\[:BTS\]:CTABLE:DATA](#) on page 215

UE measurements:

[CONFigure:WCDPower:MS:CTABLE:DATA](#) on page 216

Conflict

Indicates a code domain conflict between channel definitions (e.g. overlapping channels).

5.2.10 Sweep settings

Access: [Sweep]

The sweep settings define how the data is measured.

Continuous Sweep / Run Cont	98
Single Sweep / Run Single	99
Continue Single Sweep	99
Refresh (MSRA only)	99
Sweep/Average Count	99

Continuous Sweep / Run Cont

After triggering, starts the sweep and repeats it continuously until stopped. This is the default setting.

While the measurement is running, "Continuous Sweep" and [RUN CONT] are highlighted. The running measurement can be aborted by selecting the highlighted softkey or key again. The results are not deleted until a new measurement is started.

Note: Sequencer. If the Sequencer is active, "Continuous Sweep" only controls the sweep mode for the currently selected channel. However, the sweep mode only takes effect the next time the Sequencer activates that channel, and only for a channel-defined sequence. In this case, a channel in continuous sweep mode is swept repeatedly.

Furthermore, [RUN CONT] controls the Sequencer, not individual sweeps. [RUN CONT] starts the Sequencer in continuous mode.

For details on the Sequencer, see the FSW base unit user manual.

Remote command:

[INITiate<n>:CONTinuous](#) on page 243

Single Sweep / Run Single

After triggering, starts the number of sweeps set in "Sweep Count". The measurement stops after the defined number of sweeps has been performed.

While the measurement is running, "Single Sweep" and [RUN SINGLE] are highlighted. The running measurement can be aborted by selecting the highlighted softkey or key again.

Note: Sequencer. If the Sequencer is active, "Single Sweep" only controls the sweep mode for the currently selected channel. However, the sweep mode only takes effect the next time the Sequencer activates that channel, and only for a channel-defined sequence. In this case, the Sequencer sweeps a channel in single sweep mode only once.

Furthermore, [RUN SINGLE] controls the Sequencer, not individual sweeps. [RUN SINGLE] starts the Sequencer in single mode.

If the Sequencer is off, only the evaluation for the currently displayed channel is updated.

For details on the Sequencer, see the FSW base unit user manual.

Remote command:

`INITiate<n>[:IMMEDIATE]` on page 244

Continue Single Sweep

After triggering, repeats the number of sweeps set in "Sweep Count", without deleting the trace of the last measurement.

While the measurement is running, "Continue Single Sweep" and [RUN SINGLE] are highlighted. The running measurement can be aborted by selecting the highlighted softkey or key again.

Remote command:

`INITiate<n>:CONMeas` on page 243

Refresh (MSRA only)

This function is only available if the Sequencer is deactivated and only for **MSRA secondary applications**.

The data in the capture buffer is re-evaluated by the currently active secondary application only. The results for any other secondary applications remain unchanged.

This is useful, for example, after evaluation changes have been made or if a new sweep was performed from another secondary application. In this case, only that secondary application is updated automatically after data acquisition.

Note: To update all active secondary applications at once, use the "Refresh All" function in the "Sequencer" menu.

Remote command:

`INITiate<n>:REFresh` on page 287

Sweep/Average Count

Defines the number of measurements to be performed in the single sweep mode. Values from 0 to 200000 are allowed. If the values 0 or 1 are set, one measurement is performed.

The sweep count is applied to all the traces in all diagrams.

If the trace modes "Average", "Max Hold" or "Min Hold" are set, this value also determines the number of averaging or maximum search procedures.

In continuous sweep mode, if "Sweep Count" = 0 (default), averaging is performed over 10 measurements. For "Sweep Count" = 1, no averaging, maxhold or minhold operations are performed.

Remote command:

[SENSe:] SWEEp:COUNT on page 219

[SENSe:] AVERAge<n>:COUNT on page 218

5.2.11 Automatic settings

Access: [AUTO SET]

Some settings can be adjusted by the FSW automatically according to the current measurement settings. In order to do so, a measurement is performed. The duration of this measurement can be defined automatically or manually.



MSRA operating mode

In MSRA operating mode, the following automatic settings are not available, as they require a new data acquisition. However, 3GPP FDD applications cannot perform data acquisition in MSRA operating mode.

Adjusting all Determinable Settings Automatically (Auto All).....	100
Setting the Reference Level Automatically (Auto Level).....	101
Autosearch for Scrambling Code.....	101
Auto Scale Window.....	101
Auto Scale All.....	101
Restore Scale (Window).....	101
Resetting the Automatic Measurement Time (Meas Time Auto).....	101
Changing the Automatic Measurement Time (Meas Time Manual).....	101
Upper Level Hysteresis.....	102
Lower Level Hysteresis.....	102

Adjusting all Determinable Settings Automatically (Auto All)

Activates all automatic adjustment functions for the current measurement settings, including:

- Auto Level
- "Autosearch for Scrambling Code" on page 65
- "Auto Scale All" on page 101

Note: MSRA operating modes. In MSRA operating mode, this function is only available for the MSRA primary, not the secondary applications.

Remote command:

[SENSe:] ADJust:ALL on page 220

Setting the Reference Level Automatically (Auto Level)

Automatically determines a reference level which ensures that no overload occurs at the FSW for the current input data. At the same time, the internal attenuators and the preamplifier (for analog baseband input: the full-scale level) are adjusted. As a result, the signal-to-noise ratio is optimized, while signal compression and clipping are minimized.

To determine the required reference level, a level measurement is performed on the FSW.

If necessary, you can optimize the reference level further. Decrease the attenuation level manually to the lowest possible value before an overload occurs, then decrease the reference level in the same way.

You can change the measurement time for the level measurement if necessary (see "Changing the Automatic Measurement Time (Meas Time Manual)" on page 101).

Remote command:

[SENSe:]ADJust:LEVel on page 222

Autosearch for Scrambling Code

Starts a search on the measured signal for all scrambling codes. The scrambling code that leads to the highest signal power is chosen as the new scrambling code.

Searching requires that the correct center frequency and level are set. The scrambling code search can automatically determine the primary scrambling code number. The secondary scrambling code number is expected as 0. Alternative scrambling codes can not be detected. Therefore the range for detection is 0x0000 – 0x1FF0h, where the last digit is always 0.

Remote command:

[SENSe:]CDPower:LCODE:SEARch[:IMMediate] on page 162

Auto Scale Window

Automatically determines the optimal range and reference level position to be displayed for the *current* measurement settings in the currently selected window. No new measurement is performed.

Auto Scale All

Automatically determines the optimal range and reference level position to be displayed for the *current* measurement settings in all displayed diagrams. No new measurement is performed.

Restore Scale (Window)

Restores the default scale settings in the currently selected window.

Resetting the Automatic Measurement Time (Meas Time Auto)

Resets the measurement duration for automatic settings to the default value.

Remote command:

[SENSe:]ADJust:CONFigure:LEVel:DURation:MODE on page 221

Changing the Automatic Measurement Time (Meas Time Manual)

This function allows you to change the measurement duration for automatic setting adjustments. Enter the value in seconds.

Note: The maximum measurement duration depends on the currently selected measurement and the installed (optional) hardware. Thus, the measurement duration actually used to determine the automatic settings can be shorter than the value you define here.

Remote command:

`[SENSe:]ADJust:CONFigure:LEVel:DURation:MODE` on page 221

`[SENSe:]ADJust:CONFigure:LEVel:DURation` on page 221

Upper Level Hysteresis

When the reference level is adjusted automatically using the [Auto Level](#) function, the internal attenuators and the preamplifier are also adjusted. To avoid frequent adaptation due to small changes in the input signal, you can define a hysteresis. This setting defines an upper threshold that the signal must exceed (compared to the last measurement) before the reference level is adapted automatically.

Remote command:

`[SENSe:]ADJust:CONFigure:HYSTeresis:UPPer` on page 222

Lower Level Hysteresis

When the reference level is adjusted automatically using the [Auto Level](#) function, the internal attenuators and the preamplifier are also adjusted. To avoid frequent adaptation due to small changes in the input signal, you can define a hysteresis. This setting defines a lower threshold that the signal must fall below (compared to the last measurement) before the reference level is adapted automatically.

Remote command:

`[SENSe:]ADJust:CONFigure:HYSTeresis:LOWer` on page 222

5.3 Time alignment error measurements

Access: "Overview" > "Select Measurement" > "Time Alignment Error"

"Time Alignment Error" measurements are only available in the 3GPP FDD BTS application.

5.3.1 Configuration overview



Access: [Meas Config] > "Overview"

For "Time Alignment Error" measurements, the "Overview" provides quick access to the following configuration dialog boxes (listed in the recommended order of processing):

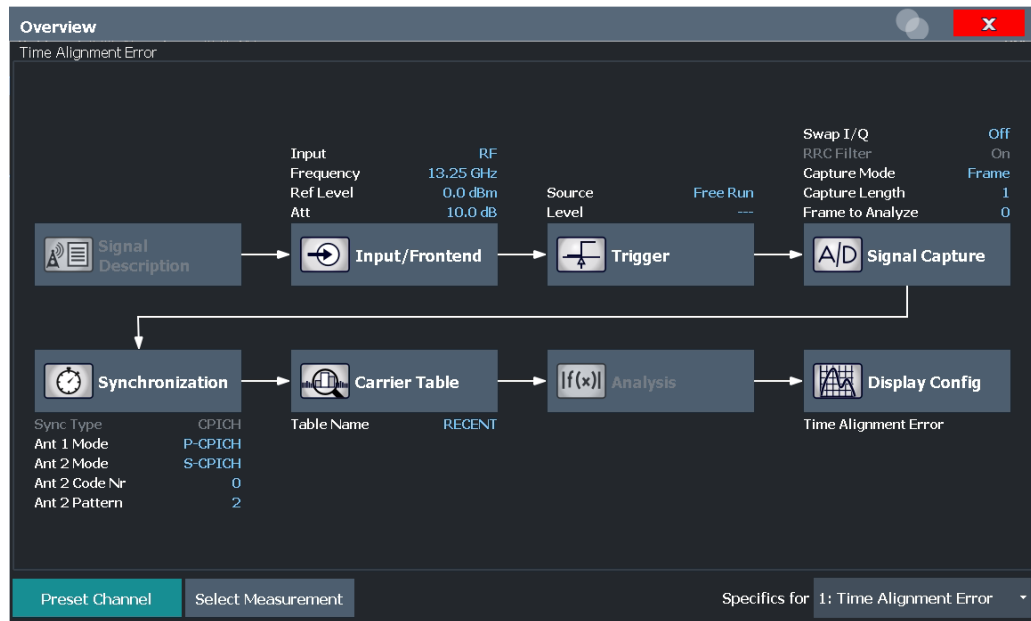

1. "Select Measurement"
See [Chapter 3, "Measurements and result display"](#), on page 16
2. "Scrambling Code"
See [Chapter 5.2.2.2, "BTS scrambling code"](#), on page 64
3. "Input/ Frontend"
See [Chapter 5.2.3, "Data input and output settings"](#), on page 67
4. (Optionally:) "Trigger"
See [Chapter 5.2.5, "Trigger settings"](#), on page 81
5. "Signal Capture"
See [Chapter 5.2.6, "Signal capture \(data acquisition\)"](#), on page 86
6. "Synchronization"
See [Chapter 5.2.8, "Synchronization \(BTS measurements only\)"](#), on page 89
7. "Carrier Table"
See [Chapter 5.3.2, "Carrier table configuration"](#), on page 104
8. "Display Configuration"
See [Chapter 3.1.2, "Evaluation methods for code domain analysis"](#), on page 19 and ["Evaluation Methods"](#) on page 34

All settings required for "Time Alignment Error" measurements are identical to those described for Code Domain Analysis (see [Chapter 5.2, "Code domain analysis"](#), on page 60).

For TAE measurement on multiple base stations, however, the carrier table must be defined.

5.3.2 Carrier table configuration

For "Time Alignment Error" measurements on signals from different base stations, the number of base stations and the transmit frequency of the base stations can be defined using a table.

5.3.2.1 Carrier table management

Access: "Overview" > "Select Measurement": "Time Alignment Error" > "Carrier Table"

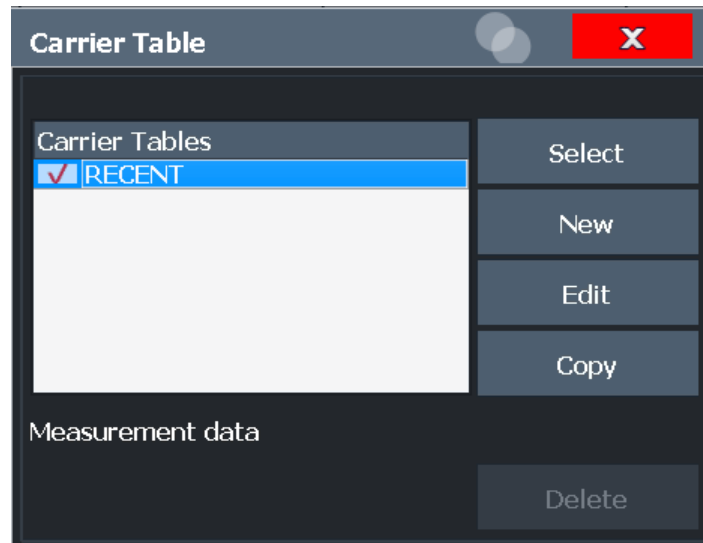

Carrier Tables.....	104
Selecting a Table.....	104
Creating a New Table.....	105
Editing a Table.....	105
Copying a Table.....	105
Deleting a Table.....	105

Carrier Tables

The list shows all carrier tables found in the default directory and marks the currently used table with a checkmark. The currently *focused* table is highlighted blue.

The default directory for carrier tables is

C:\R_S\INSTR\USER\chan_tab\carrier_table\.

Remote command:

[SENSe:] TAERror:CATalog on page 231

Selecting a Table

Selects the currently highlighted carrier table.

Remote command:

[SENSe:] TAERror:PRESet on page 231

Creating a New Table

Creates a new carrier table. See [Chapter 5.3.2.2, "Carrier table settings and functions"](#), on page 105.

Remote command:

[SENSe:] TAERror:NEW on page 231

Editing a Table

You can edit existing carrier table definitions. The details of the selected carrier are displayed in the "Carrier table" dialog box. See [Chapter 5.3.2.2, "Carrier table settings and functions"](#), on page 105.

Copying a Table

Copies an existing carrier table definition. The details of the selected carrier are displayed in the "Carrier table" dialog box. See [Chapter 5.3.2.2, "Carrier table settings and functions"](#), on page 105.

Deleting a Table

Deletes the currently selected carrier table after a message is confirmed.

The default table ("RECENT") cannot be deleted.

Remote command:

[SENSe:] TAERror:DELeTe on page 231

5.3.2.2 Carrier table settings and functions

Access: "Overview" > "Select Measurement": "Time Alignment Error" > "Carrier Table" > "New"/ "Copy"/ "Edit"

Some general settings and functions are available when configuring a carrier table.

Carrier	Frequency Offset	Scram Code	Ant-1 CPICH #	Pattern	Ant-2 CPICH #	Pattern	Conflict
Ref	13.25 GHz	00	0	Pattern 1	0	Pattern 2	

Name.....	106
Comment.....	106
Adding a Carrier.....	106
Deleting a Carrier.....	106
Selecting the Scrambling Code Format.....	106
Cancelling and Closing Configuration.....	106
Saving the Table.....	106

Name

Name of the carrier table that will be displayed in the "Carrier Tables" list.

Comment

Optional description of the carrier table.

Adding a Carrier

Inserts a new row in the carrier table to define another carrier. Up to 4 carriers can be defined.

Remote command:

[\[SENSe:\]TAERror:CARRier<c>:INSert](#) on page 229

Deleting a Carrier

Deletes the currently selected carrier from the table.

Remote command:

[\[SENSe:\]TAERror:CARRier<c>:DELete](#) on page 229

Selecting the Scrambling Code Format

The [Scrambling Code](#) can be defined in hexadecimal (default) or in decimal format.

Cancelling and Closing Configuration

Closes the "Carrier Table Settings" dialog box without saving the changes.

Saving the Table

Saves the changes to the table and closes the "Carrier Table Settings" dialog box.

The new or edited table is stored in the default directory for carrier tables:

C:\R_S\INSTR\USER\chan_tab\carrier_table\.

Remote command:

[\[SENSe:\]TAERror:SAVE](#) on page 232

5.3.2.3 Carrier details

Access: "Overview" > "Select Measurement": "Time Alignment Error" > "Carrier Table" > "New"/ "Copy"/ "Edit"

Carrier Table

Carrier Table Setting

Name:

Comment:

Carrier	Frequency Offset	Scram Code	Ant-1 CPICH #	Pattern	Ant-2 CPICH #	Pattern	Conflict
Ref	13.25 GHz	00	0	Pattern 1	0	Pattern 2	

Buttons: Add Carrier, Delete Carrier, Scram Code (Hex, Dec), Cancel, Save Table

Carrier.....	107
Frequency Offset.....	107
Scrambling Code.....	108
Antenna 1: CPICH-Number.....	108
Antenna 1: CPICH-Pattern.....	108
Antenna 2: CPICH-Number.....	108
Antenna 2: CPICH-Pattern.....	108
Conflict.....	108

Carrier

Consecutive carrier number. The first carrier to be defined is used as the reference carrier for relative measurement results.

Remote command:

[SENSe:] TAERror:CARRier<c>:COUNT on page 229

Frequency Offset

The frequency offset with respect to the reference carrier. (The reference carrier is set to the current center frequency, thus the offset is always 0.)

By default, an offset of 5 MHz is defined for each newly inserted carrier. The minimum spacing between two carriers is 2.5 MHz. If this minimum spacing is not maintained, a **Conflict** is indicated and the conflicting carriers are indicated below the table.

The maximum positive and negative frequency offset which a carrier can have from the reference depends on the available analysis bandwidth (see "[Carrier frequencies](#)" on page 56).

If the maximum offsets from the reference are exceeded, a **Conflict** is indicated and the carrier that is out of range is indicated below the table.

Remote command:

[SENSe:] TAERror:CARRier<c>:OFFSet on page 230

Scrambling Code

The scrambling code identifying the base station transmitting the signal. This code can be defined in hexadecimal (default) or decimal format (see ["Selecting the Scrambling Code Format"](#) on page 106).

The scrambling code for the reference carrier is taken from the Signal Description settings for CDA measurements (see [Chapter 5.2.2.2, "BTS scrambling code"](#), on page 64).

Remote command:

[\[SENSe:\]TAERror:CARRier<c>:SCODE](#) on page 230

Antenna 1: CPICH-Number

The CPICH number used for synchronization

Remote command:

[\[SENSe:\]TAERror:CARRier<c>:ANTenna<antenna>:CPICH](#) on page 228

Antenna 1: CPICH-Pattern

The CPICH pattern used for synchronization

If "NONE" is selected, this antenna is considered to be unused. The time alignment error of this antenna is not measured and its status does not enter into the overall status for the overall signal.

Remote command:

[\[SENSe:\]TAERror:CARRier<c>:ANTenna<antenna>:PATTern](#) on page 228

Antenna 2: CPICH-Number

The CPICH number used for synchronization

Remote command:

[\[SENSe:\]TAERror:CARRier<c>:ANTenna<antenna>:CPICH](#) on page 228

Antenna 2: CPICH-Pattern

The CPICH pattern used for synchronization

If "NONE" is selected, this antenna is considered to be unused. The time alignment error of this antenna is not measured and its status does not enter into the overall status for the overall signal.

Remote command:

[\[SENSe:\]TAERror:CARRier<c>:ANTenna<antenna>:PATTern](#) on page 228

Conflict

Indicates a conflict between carriers, such as overlapping frequencies or frequencies outside the allowed range (see ["Frequency Offset"](#) on page 107). The detailed conflict message is displayed beneath the carrier table.

5.4 RF measurements

3GPP FDD measurements require a special application on the FSW, which you activate using [MODE].

When you activate a 3GPP FDD application, Code Domain Analysis of the input signal is started automatically. However, the 3GPP FDD applications also provide various RF measurement types.

Selecting the measurement type

- ▶ To select an RF measurement type, do one of the following:
 - Select "Overview". In the "Overview", select "Select Measurement". Select the required measurement.
 - Press [MEAS]. In the "Select Measurement" dialog box, select the required measurement.

Some parameters are set automatically according to the 3GPP standard the first time a measurement is selected (since the last PRESET operation). A list of these parameters is given with each measurement type. The parameters can be changed, but are not reset automatically the next time you re-enter the measurement.

The main measurement configuration menus for the RF measurements are identical to the Spectrum application.

For details refer to "General Measurement Configuration" in the FSW User Manual.

The measurement-specific settings for the following measurements are available in the "Analysis" dialog box (via the "Overview").

• Channel power (ACLR) measurements	109
• Occupied bandwidth	110
• Output power measurements	110
• Spectrum emission mask	111
• RF combi	111
• CCDF	112

5.4.1 Channel power (ACLR) measurements

"Channel Power ACLR" measurements are performed as in the Spectrum application with the following predefined settings according to 3GPP specifications (adjacent channel leakage ratio).

Table 5-2: Predefined settings for 3GPP FDD ACLR Channel Power measurements

Standard	(BTS measurements only): "Normal" base station
Number of adjacent channels	2

For further details about the ACLR measurements refer to "Measuring Channel Power and Adjacent-Channel Power" in the FSW User Manual.

To restore adapted measurement parameters, the following parameters are saved on exiting and are restored on re-entering this measurement:

- Reference level and reference level offset
- RBW, VBW
- Sweep time

- Span
- Number of adjacent channels
- Fast ACLR mode

The main measurement menus for the RF measurements are identical to the Spectrum application. However, for SEM and ACLR measurements in BTS measurements, an additional softkey is available to select the required standard.

BTS Standard

Switches between Normal mode and Home BS (Home Base Station) mode. Switching this parameter changes the limits according to the specifications.

Remote command:

[CONFigure:WCDPower\[:BTS\]:STD](#) on page 233

5.4.2 Occupied bandwidth

The "Occupied Bandwidth" measurement determines the bandwidth that the signal occupies. The occupied bandwidth is defined as the bandwidth in which – in default settings - 99 % of the total signal power is to be found. The percentage of the signal power to be included in the bandwidth measurement can be changed.

The "Occupied Bandwidth" measurement is performed as in the Spectrum application with default settings.

Table 5-3: Predefined settings for 3GPP FDD OBW measurements

Setting	Default value
% Power Bandwidth	99 %
Channel bandwidth	3.84 MHz

For further details about the "Occupied Bandwidth" measurements refer to "Measuring the Occupied Bandwidth" in the FSW User Manual.

To restore adapted measurement parameters, the following parameters are saved on exiting and are restored on re-entering this measurement:

- Reference level and reference level offset
- RBW, VBW
- Sweep time
- Span

5.4.3 Output power measurements

The Output Power measurement determines the 3GPP FDD signal channel power.

In order to determine the Output Power, the 3GPP FDD application performs a Channel Power measurement as in the Spectrum application with the following settings:

Table 5-4: Predefined settings for 3GPP FDD Output Channel Power measurements

Standard	W-CDMA 3GPP REV (BTS) / W-CDMA 3GPP FWD (UE) By default, the "Normal" base station standard is used. However, you can switch to the "Home" base station standard using the BTS Standard softkey.
Number of adjacent channels	0

5.4.4 Spectrum emission mask

The "Spectrum Emission Mask" measurement determines the power of the 3GPP FDD signal in defined offsets from the carrier and compares the power values with a spectral mask specified by 3GPP.

For further details about the "Spectrum Emission Mask" measurements refer to "Spectrum Emission Mask Measurement" in the FSW User Manual.

The 3GPP FDD applications perform the SEM measurement as in the Spectrum application with the following settings:

Table 5-5: Predefined settings for 3GPP FDD SEM measurements

Standard	W-CDMA 3GPP REV (BTS) / W-CDMA 3GPP FWD (UE) By default, the "Normal" base station standard is used. However, you can switch to the "Home" base station standard using the BTS Standard softkey.
Span	+/- 8 MHz
Number of ranges	11
Fast SEM	ON
Number of power classes	4
Power reference type	Channel power



Changing the RBW and the VBW is restricted due to the definition of the limits by the standard.

To restore adapted measurement parameters, the following parameters are saved on exiting and are restored on re-entering this measurement:

- Reference level and reference level offset
- Sweep time
- Span

5.4.5 RF combi

This measurement combines the following measurements:

- [Chapter 5.4.1, "Channel power \(ACLR\) measurements"](#), on page 109
- [Chapter 5.4.2, "Occupied bandwidth"](#), on page 110

- [Chapter 5.4.4, "Spectrum emission mask"](#), on page 111

The advantage of the "RF Combi" measurement is that all RF results are measured with a single measurement process. This measurement is faster than the three individual measurements.

The "RF Combi" measurement is performed as in the Spectrum application with the following settings:

Table 5-6: Predefined settings for 3GPP FDD RF Combi measurements

Standard	W-CDMA 3GPP REV (BTS) / W-CDMA 3GPP FWD (UE) By default, the "Normal" base station standard is used. However, you can switch to the "Home" base station standard using the BTS Standard softkey.
Number of adjacent channels	2
Span	25.5 MHz
Detector	RMS
RBW	30 kHz
Sweep time	100 ms
CP/ACLR	Active on trace 1
OBW	Active on trace 1
SEM	Active on trace 2

To restore adapted measurement parameters, the following parameters are saved on exiting and are restored on re-entering this measurement:

- RBW, VBW
- Sweep time
- Span
- Number of adjacent channels

5.4.6 CCDF

The "CCDF" measurement determines the distribution of the signal amplitudes (complementary cumulative distribution function).

The "CCDF" measurement is performed as in the Spectrum application with the following settings:

Table 5-7: Predefined settings for 3GPP FDD CCDF measurements

"CCDF"	Active on trace 1
Analysis bandwidth	10 MHz
Number of samples	62500
VBW	5 MHz

For further details about the "CCDF" measurements refer to "Statistical Measurements" in the FSW User Manual.

To restore adapted measurement parameters, the following parameters are saved on exiting and are restored on re-entering this measurement:

- Reference level and reference level offset
- Analysis bandwidth
- Number of samples

6 Analysis

Access: "Overview" > "Analysis"

General result analysis settings concerning the evaluation range, trace, markers, etc. can be configured



Analysis of RF Measurements

General result analysis settings concerning the trace, markers, lines etc. for RF measurements are identical to the analysis functions in the Spectrum application except for some special marker functions and spectrograms, which are not available in the 3GPP FDD applications.

For details see the "Common Analysis and Display Functions" chapter in the FSW User Manual.

The remote commands required to perform these tasks are described in [Chapter 11.10, "Analysis"](#), on page 273.

- [Evaluation range](#)..... 114
- [Code domain settings \(BTS measurements\)](#)..... 117
- [Code domain settings \(UE measurements\)](#)..... 119
- [Traces](#)..... 120
- [Trace / data export configuration](#)..... 122
- [Markers](#)..... 123

6.1 Evaluation range

Access: "Overview" > "Analysis" > "Evaluation Range"

or: [MEAS CONFIG] > "Evaluation Range"

The evaluation range defines which channel, slot or frame is evaluated in the result display.

For UE measurements, the branch to be evaluated can also be defined.

Channel.....	115
(CPICH) Slot.....	116
Frame To Analyze.....	116
Branch (UE measurements only).....	116
└ Details / Hide.....	116
└ Selecting a Different Branch for a Window.....	117

Channel

Selects a channel for the following evaluations:

- Code Domain Power
- Power vs Slot
- Symbol Constellation
- Symbol EVM

Enter a channel number and spreading factor, separated by a decimal point.

The specified channel is selected and marked in red, if active. If no spreading factor is specified, the code on the basis of the spreading factor 512 is marked. For unused channels, the code resulting from the conversion is marked.

Example: Enter 5.128

Channel 5 is marked at spreading factor 128 (30 kbps) if the channel is active, otherwise code 20 at spreading factor 512.

Remote command:

[SENSe:] CDPower:CODE on page 223

(CPICH) Slot

Selects the (CPICH) slot for evaluation. This affects the following evaluations (see also [Chapter 3.1.2, "Evaluation methods for code domain analysis"](#), on page 19):

- "Code Domain Power"
- "Peak Code Domain Error"
- "Result Summary"
- "Composite Constellation"
- "Code Domain Error Power"
- "Channel Table"
- "Power vs Symbol"
- Symbol Const
- "Symbol EVM"
- "Bitstream"

Remote command:

[\[SENSe:\]CDPower:SLOT](#) on page 223

Frame To Analyze

Defines the frame to be analyzed and displayed.

Note: if this setting is not available in UE tests, [Capture Mode](#) is set to "Slot", i.e. only one slot is captured.

Remote command:

[\[SENSe:\]CDPower:FRAMe\[:VALue\]](#) on page 223

Branch (UE measurements only)

Switches between the evaluation of the I and the Q branch in UE measurements.

Remote command:

[\[SENSe:\]CDPower:MAPPING](#) on page 223

Details / Hide ← Branch (UE measurements only)

Access: "Overview" > "Analysis" > "Evaluation Range" > "Details"/"Hide"

By default, the same branch is used for all evaluations. However, you can select a different branch for individual windows.

Selecting a Different Branch for a Window ← Branch (UE measurements only)

By default, the same (common) branch is used by all windows, namely the one specified by the [Branch \(UE measurements only\)](#) setting.

In order to evaluate a different branch for an individual window, toggle the "Use Common Branch" setting to "No". Select the window from the list of active windows under "Specifics for", then select the "Branch".

Remote command:

[\[SENSe:\]CDPower:MAPPING](#) on page 223

6.2 Code domain settings (BTS measurements)

Access: "Overview" > "Analysis" > "Code Domain Settings"

or: [MEAS CONFIG] > "Code Domain Settings"

Some evaluations provide further settings for the results. The settings for BTS measurements are described here.

Analysis	
Trace	Code Domain Analyzer Common
	Compensate I/Q Offset <input type="radio"/> On <input checked="" type="radio"/> Off
Evaluation Range	Code Domain Power
	Code Power Display <input type="radio"/> Absolute <input checked="" type="radio"/> Relative
Code Domain Settings	Power Reference <input type="radio"/> Total <input checked="" type="radio"/> CPICH
	Power vs Slot
Marker	Show Difference to Previous Slot <input type="radio"/> On <input checked="" type="radio"/> Off
	Bitstream
	Constellation Parameter B <input type="text" value="0"/>

Compensate IQ Offset.....	118
Code Power Display.....	118
Show Difference to Previous Slot.....	118
Constellation Parameter B.....	119

Compensate IQ Offset

If enabled, the I/Q offset is eliminated from the measured signal. This is useful to deduct a DC offset to the baseband caused by the DUT, thus improving the EVM. Note, however, that for EVM measurements according to standard, compensation must be disabled.

Remote command:

[\[SENSe:\]CDPower:NORMalize](#) on page 225

Code Power Display

For "Code Domain Power" evaluation:

Defines whether the absolute power or the power relative to the chosen reference is displayed.

"TOT" Relative to the total signal power

"CPICH" Relative to the power of the CPICH

Remote command:

[\[SENSe:\]CDPower:PDISplay](#) on page 225

[\[SENSe:\]CDPower:PREference](#) on page 226

Show Difference to Previous Slot

For Power vs. Slot evaluation:

If enabled, the slot power difference between the current slot and the previous slot is displayed in the "Power vs. Slot" evaluation.

Remote command:

[SENSe:]CDPower:PDIFf on page 226

Constellation Parameter B

For "Bitstream" evaluation:

Defines the constellation parameter B. According to 3GPP specification, the mapping of 16QAM symbols to an assigned bitstream depends on the constellation parameter B. This parameter can be adjusted to decide which bit mapping should be used for bitstream evaluation.

Remote command:

[SENSe:]CDPower:CPB on page 225

6.3 Code domain settings (UE measurements)

Access: "Overview" > "Analysis" > "Code Domain Settings"

or: [MEAS CONFIG] > "Code Domain Settings"

Some evaluations provide further settings for the results. The settings for UE measurements are described here.

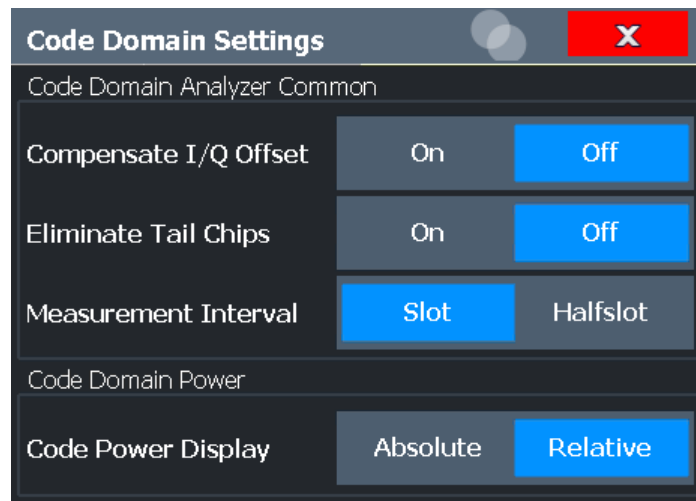

Measurement Interval.....	119
Compensate IQ Offset.....	120
Eliminate Tail Chips.....	120
Code Power Display.....	120

Measurement Interval

Switches between the analysis of a half slot or a full slot.

Both measurement intervals are influenced by the settings of [Eliminate Tail Chips](#): If "Eliminate Tail Chips" is set to "On", 96 chips at both ends of the measurement interval are not taken into account for analysis.

"Slot" The length of each analysis interval is 2560 chips, corresponding to one time slot of the 3GPP signal. The time reference for the start of slot 0 is the start of a 3GPP radio frame.

"Halfslot" The length of each analysis interval is reduced to 1280 chips, corresponding to half of one time slot of the 3GPP signal.

Remote command:

[\[SENSe:\]CDPower:HSLOT](#) on page 227

Compensate IQ Offset

If enabled, the I/Q offset is eliminated from the measured signal. This is useful to deduct a DC offset to the baseband caused by the DUT, thus improving the EVM. Note, however, that for EVM measurements according to standard, compensation must be disabled.

Remote command:

[\[SENSe:\]CDPower:NORMALize](#) on page 225

Eliminate Tail Chips

Selects the length of the measurement interval for calculation of error vector magnitude (EVM) in accordance with 3GPP specification Release 5.

"On" Changes of power are expected. Therefore an EVM measurement interval of one slot minus 25 µs at each end of the burst (3904 chips) is considered.

"Off" Changes of power are not expected. Therefore an EVM measurement interval of one slot (4096 chips) is considered. (Default settings)

Remote command:

[\[SENSe:\]CDPower:ETCHips](#) on page 227

Code Power Display

For "Code Domain Power" evaluation:

Defines whether the absolute power or the power relative to the total signal is displayed.

"Absolute" Absolute power levels

"Relative" Relative to the total signal power

Remote command:

[\[SENSe:\]CDPower:PDISplay](#) on page 225

6.4 Traces

Access: "Overview" > "Analysis" > "Trace"

Or: [TRACE] > "Trace Config"

The trace settings determine how the measured data is analyzed and displayed on the screen.

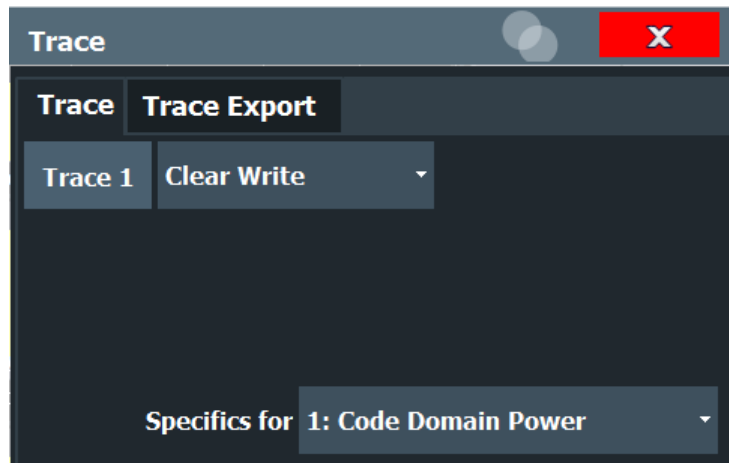

In CDA evaluations, only one trace can be active in each diagram at any time.



Trace data from measurements in the R&S FSW 3GPP FDD Measurements application can be exported to an ASCII file using the common FSW trace export functionality. For details, see the trace configuration chapter in the FSW User Manual.



Window-specific configuration

The settings in this dialog box are specific to the selected window. To configure the settings for a different window, select the window outside the displayed dialog box, or select the window from the "Specifics for" selection list in the dialog box.

Trace Mode

Defines the update mode for subsequent traces.

"Clear/ Write"	Overwrite mode (default): the trace is overwritten by each measurement. All available detectors can be selected.
"Max Hold"	The maximum value is determined over several measurements and displayed. The FSW saves the measurement result in the trace memory only if the new value is greater than the previous one.
"Min Hold"	The minimum value is determined from several measurements and displayed. The FSW saves the measurement result in the trace memory only if the new value is lower than the previous one.
"Average"	The average is formed over several measurements. The Sweep/Average Count determines the number of averaging procedures.

"View" The current contents of the trace memory are frozen and displayed.
Note: If a trace is frozen, you can change the measurement settings, apart from scaling settings, without impact on the displayed trace. The fact that the displayed trace no longer matches the current measurement settings is indicated by a yellow asterisk * on the tab label. If you change any parameters that affect the scaling of the diagram axes, the FSW automatically adapts the trace data to the changed display range. Thus, you can zoom into the diagram after the measurement to show details of the trace.

"Blank" Removes the selected trace from the display.

Remote command:

DISPlay[:WINDow<n>] [:SUBWindow<w>]:TRACe<t>:MODE on page 273

6.5 Trace / data export configuration



Access: "Save" > "Export" > "Export Configuration"

Or: [TRACE] > "Trace Config" > "Trace / Data Export"



The standard data management functions (e.g. saving or loading instrument settings) that are available for all FSW applications are not described here.

See the FSW base unit user manual for a description of the standard functions.

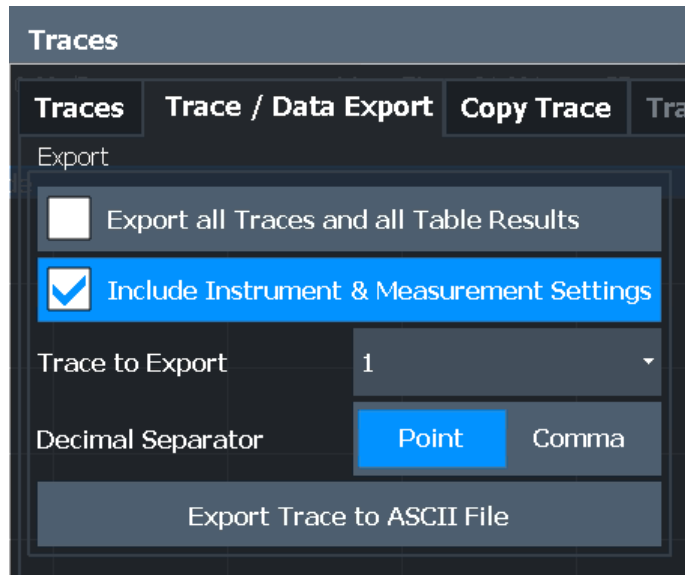

Export all Traces and all Table Results.....	123
Include Instrument & Measurement Settings.....	123
Trace to Export.....	123
Decimal Separator.....	123

Export all Traces and all Table Results

Selects all displayed traces and result tables (e.g. "Result Summary", marker table etc.) in the current application for export to an ASCII file.

Alternatively, you can select one specific trace only for export (see [Trace to Export](#)).

The results are output in the same order as they are displayed on the screen: window by window, trace by trace, and table row by table row.

Remote command:

`FORMat:DEXPort:TRACes` on page 269

Include Instrument & Measurement Settings

Includes additional instrument and measurement settings in the header of the export file for result data.

See the FSW base unit user manual for details.

Remote command:

`FORMat:DEXPort:HEADer` on page 269

Trace to Export

Defines an individual trace to be exported to a file.

This setting is not available if [Export all Traces and all Table Results](#) is selected.

Decimal Separator

Defines the decimal separator for floating-point numerals for the data export/import files. Evaluation programs require different separators in different languages.

Remote command:

`FORMat:DEXPort:DSEParator` on page 268

6.6 Markers

Access: "Overview" > "Analysis" > "Marker"

Or: [MKR]

Markers help you analyze your measurement results by determining particular values in the diagram. Thus you can extract numeric values from a graphical display.

**Markers in Code Domain Analysis measurements**

In Code Domain Analysis measurements, the markers are set to individual symbols, codes, slots or channels, depending on the result display. Thus you can use the markers to identify individual codes, for example.

- [Individual marker settings](#)..... 124
- [General marker settings](#)..... 125
- [Marker search settings](#)..... 126
- [Marker positioning functions](#)..... 127

6.6.1 Individual marker settings

Access: "Overview" > "Analysis" > "Marker" > "Markers"

Or: [MKR] > "Marker Config"

In CDA evaluations, up to four markers can be activated in each diagram at any time.

Selected	State	X Value	Type
Marker 1	On <input type="checkbox"/> Off <input checked="" type="checkbox"/>	0	Norm Delta
Delta 1	On <input type="checkbox"/> Off <input checked="" type="checkbox"/>	0	Norm Delta
Delta 2	On <input type="checkbox"/> Off <input checked="" type="checkbox"/>	0	Norm Delta
Delta 3	On <input type="checkbox"/> Off <input checked="" type="checkbox"/>	0	Norm Delta
Delta 4	On <input type="checkbox"/> Off <input checked="" type="checkbox"/>	0	Norm Delta

All Marker Off

Specifics for 1: Code Domain Power

Selected Marker.....	124
Marker State.....	124
X-value.....	125
Marker Type.....	125
All Markers Off.....	125

Selected Marker

Marker name. The marker which is currently selected for editing is highlighted orange.

Remote command:

Marker selected via suffix <m> in remote commands.

Marker State

Activates or deactivates the marker in the diagram.

Remote command:

[CALCulate<n>:MARKer<m>\[:STATe\]](#) on page 275

[CALCulate<n>:DELTaMarker<m>\[:STATe\]](#) on page 276

X-value

Defines the position of the marker on the x-axis (channel, slot, symbol, depending on evaluation).

Remote command:

[CALCulate<n>:DELTaMarker<m>:X](#) on page 277

[CALCulate<n>:MARKer<m>:X](#) on page 275

Marker Type

Toggles the marker type.

The type for marker 1 is always "Normal", the type for delta marker 1 is always "Delta". These types cannot be changed.

Note: If normal marker 1 is the active marker, switching the "Mkr Type" activates an additional delta marker 1. For any other marker, switching the marker type does not activate an additional marker, it only switches the type of the selected marker.

"Normal" A normal marker indicates the absolute value at the defined position in the diagram.

"Delta" A delta marker defines the value of the marker relative to the specified reference marker (marker 1 by default).

Remote command:

[CALCulate<n>:MARKer<m>\[:STATe\]](#) on page 275

[CALCulate<n>:DELTaMarker<m>\[:STATe\]](#) on page 276

All Markers Off

Deactivates all markers in one step.

Remote command:

[CALCulate<n>:MARKer<m>:AOFF](#) on page 276

6.6.2 General marker settings

Access: "Overview" > "Analysis" > "Marker" > "Marker Settings"

Or: [MKR] > "Marker Config" > "Marker Settings" tab

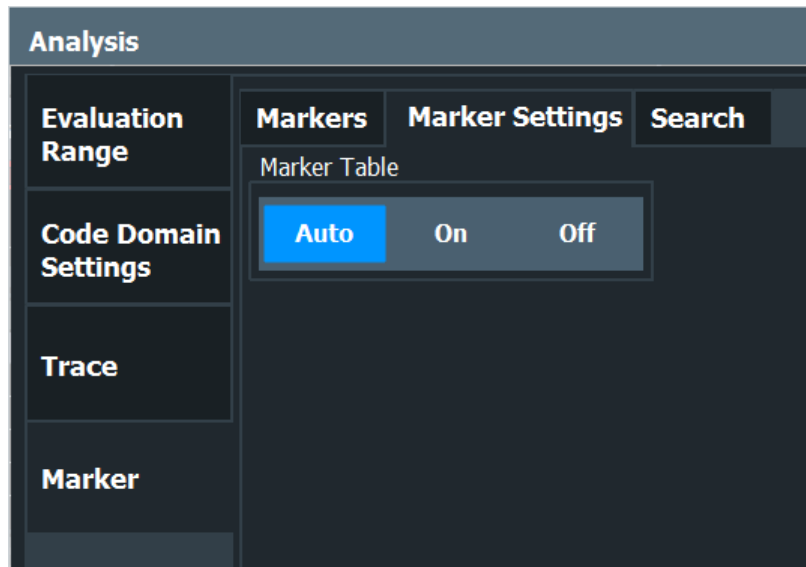

Marker Table Display

Defines how the marker information is displayed.

- "On" Displays the marker information in a table in a separate area beneath the diagram.
- "Off" No separate marker table is displayed. The marker information is displayed within the diagram area.
- "Auto" (Default) If more than two markers are active, the marker table is displayed automatically. The marker information for up to two markers is displayed in the diagram area.

Remote command:

[DISPlay\[:WINDow<n>\]:MTABLE](#) on page 278

6.6.3 Marker search settings

Access: "Overview" > "Analysis" > "Marker" > "Search"

Access: [MKR ->] > "Search Config"

Several functions are available to set the marker to a specific position very quickly and easily. In order to determine the required marker position, searches can be performed. The search results are affected by special settings.

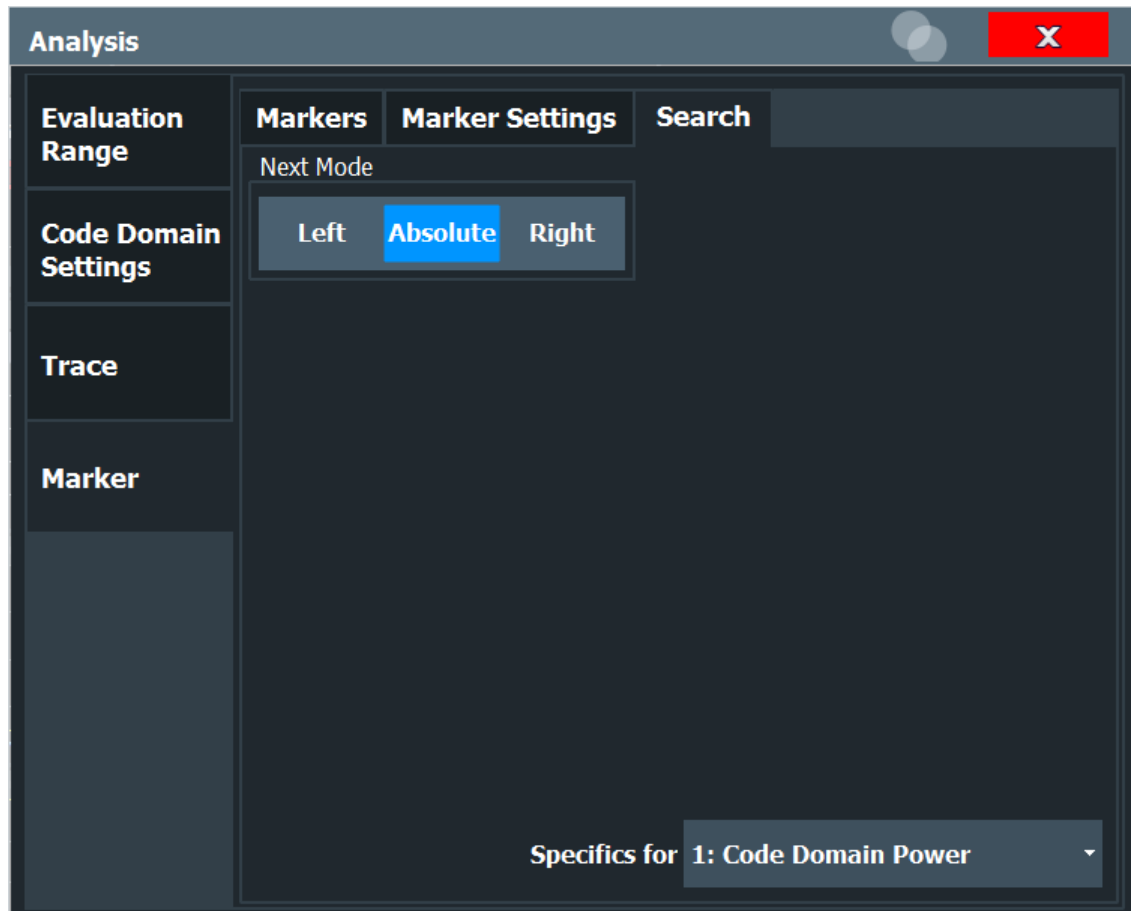

[Search Mode for Next Peak](#)..... 127

Search Mode for Next Peak

Selects the search mode for the next peak search.

"Left"	Determines the next maximum/minimum to the left of the current peak.
"Absolute"	Determines the next maximum/minimum to either side of the current peak.
"Right"	Determines the next maximum/minimum to the right of the current peak.

Remote command:

[Chapter 11.10.2.3, "Positioning the marker"](#), on page 279

6.6.4 Marker positioning functions

Access: [MKR ->]

The following functions set the currently selected marker to the result of a peak search.



Markers in Code Domain Analysis measurements

In Code Domain Analysis measurements, the markers are set to individual symbols, codes, slots or channels, depending on the result display. Thus you can use the markers to identify individual codes, for example.

Search Next Peak.....	128
Search Next Minimum.....	128
Peak Search.....	128
Search Minimum.....	128
Marker To CPICH.....	129
Marker To PCCPCH.....	129

Search Next Peak

Sets the selected marker/delta marker to the next (lower) maximum of the assigned trace. If no marker is active, marker 1 is activated.

Remote command:

`CALCulate<n>:MARKer<m>:MAXimum:NEXT` on page 280
`CALCulate<n>:MARKer<m>:MAXimum:RIGHT` on page 280
`CALCulate<n>:MARKer<m>:MAXimum:LEFT` on page 280
`CALCulate<n>:DELTamarker<m>:MAXimum:NEXT` on page 282
`CALCulate<n>:DELTamarker<m>:MAXimum:RIGHT` on page 283
`CALCulate<n>:DELTamarker<m>:MAXimum:LEFT` on page 282

Search Next Minimum

Sets the selected marker/delta marker to the next (higher) minimum of the selected trace. If no marker is active, marker 1 is activated.

Remote command:

`CALCulate<n>:MARKer<m>:MINimum:NEXT` on page 281
`CALCulate<n>:MARKer<m>:MINimum:LEFT` on page 280
`CALCulate<n>:MARKer<m>:MINimum:RIGHT` on page 281
`CALCulate<n>:DELTamarker<m>:MINimum:NEXT` on page 283
`CALCulate<n>:DELTamarker<m>:MINimum:LEFT` on page 283
`CALCulate<n>:DELTamarker<m>:MINimum:RIGHT` on page 284

Peak Search

Sets the selected marker/delta marker to the maximum of the trace. If no marker is active, marker 1 is activated.

Remote command:

`CALCulate<n>:MARKer<m>:MAXimum[:PEAK]` on page 280
`CALCulate<n>:DELTamarker<m>:MAXimum[:PEAK]` on page 283

Search Minimum

Sets the selected marker/delta marker to the minimum of the trace. If no marker is active, marker 1 is activated.

Remote command:

`CALCulate<n>:MARKer<m>:MINimum[:PEAK]` on page 281
`CALCulate<n>:DELTamarker<m>:MINimum[:PEAK]` on page 284

Marker To CPICH

Sets the marker to the CPICH channel.

Remote command:

[CALCulate<n>:MARKer<m>:FUNction:CPICH](#) on page 279

Marker To PCCPCH

Sets the marker to the PCCPCH channel.

Remote command:

[CALCulate<n>:MARKer<m>:FUNction:PCCPch](#) on page 279

7 I/Q data import and export

Baseband signals mostly occur as so-called complex baseband signals, i.e. a signal representation that consists of two channels; the inphase (I) and the quadrature (Q) channel. Such signals are referred to as I/Q signals. The complete modulation information and even distortion that originates from the RF, IF or baseband domains can be analyzed in the I/Q baseband.



Importing and exporting I/Q signals is useful for various applications:

- Generating and saving I/Q signals in an RF or baseband signal generator or in external software tools to analyze them with the FSW later.
The FSW supports various I/Q data formats for import.
For details on formats, see the FSW I/Q Analyzer and I/Q Input user manual.
- Capturing and saving I/Q signals with the FSW to analyze them with the FSW or an external software tool later
As opposed to storing trace data, which can be averaged or restricted to peak values, I/Q data is stored as it was captured, without further processing. Multi-channel data is not supported.
The data is stored as complex values in 32-bit floating-point format.
The file type is determined by the file extension. If no file extension is provided, the file type is assumed to be `.iq.tar`. For `.mat` files, Matlab® v4 is assumed.
For a detailed description, see the FSW I/Q Analyzer and I/Q Input User Manual.



An application note on converting Rohde & Schwarz I/Q data files is available from the Rohde & Schwarz website:

[1EF85: Converting R&S I/Q data files](#)

The import and export functions are available in the "Save/Recall" menu which is displayed when you select the  "Save" or  "Open" icon in the toolbar.

See the FSW I/Q Analyzer and I/Q Input User Manual.



Export only in MSRA mode

In MSRA mode, I/Q data can only be exported to other applications; I/Q data cannot be imported to the MSRA primary or any MSRA secondary applications.

8 Optimizing and troubleshooting the measurement

If the results do not meet your expectations, try the following methods to optimize the measurement:

Synchronization fails:

- Check the frequency.
- Check the reference level.
- Check the scrambling code.
- When using an external trigger, check whether an external trigger is being sent to the FSW.

8.1 Error messages

Error messages are entered in the error/event queue of the status reporting system in the remote control mode and can be queried with the command `SYSTem:ERRor?`.

A short explanation of the device-specific error messages for the 3GPP FDD applications is given below.

Status bar message	Description
Sync not found	This message is displayed if synchronization is not possible. Possible causes are that frequency, level, scrambling code, Invert Q values are set incorrectly, or the input signal is invalid.
Sync OK	This message is displayed if synchronization is possible.
Incorrect pilot symbols	This message is displayed if one or more of the received pilot symbols are not equal to the specified pilot symbols of the 3GPP standard. Possible causes are: <ul style="list-style-type: none"> • Incorrectly sent pilot symbols in the received frame. • Low signal to noise ratio (SNR) of the W-CDMA signal. • One or more code channels have a significantly lower power level compared to the total power. The incorrect pilots are detected in these channels because of low channel SNR. • One or more channels are sent with high power ramping. In slots with low relative power to total power, the pilot symbols might be detected incorrectly (check the signal quality by using the symbol constellation display

9 How to perform measurements in 3GPP FDD applications

The following step-by-step instructions demonstrate how to perform measurements with the 3GPP FDD applications.

To perform Code Domain Analysis

1. Press [MODE] and select the "3GPP FDD BTS" applications for base station tests, or "3GPP FDD UE" for user equipment tests.
Code Domain Analysis of the input signal is performed by default.
2. Select "Overview" to display the "Overview" for Code Domain Analysis.
3. Select "Signal Description" and configure the expected input signal and used scrambling code.
4. Select "Input/Frontend" and then the "Frequency" tab to define the input signal's center frequency.
5. Optionally, select "Trigger" and define a trigger for data acquisition, for example an external trigger to start capturing data only when a useful signal is transmitted.
6. Select "Signal Capture" and define the acquisition parameters for the input signal. In MSRA mode, define the application data instead, see ["To select the application data for MSRA measurements"](#) on page 135.
7. If necessary, select "Synchronization" and change the channel synchronization settings.
8. Select "Channel Detection" and define how the individual channels are detected within the input signal. If necessary, define a channel table as described in ["To define or edit a channel table"](#) on page 133.
9. Select "Display Config" and select the evaluation methods that are of interest to you.
Arrange them on the display to suit your preferences.
10. Exit the SmartGrid mode and select "Overview" to display the "Overview" again.
11. Select "Analysis" in the "Overview" to configure how the data is evaluated in the individual result displays.
 - Select the channel, slot or frame to be evaluated.
 - Configure specific settings for the selected evaluation method(s).
 - Optionally, configure the trace to display the average over a series of sweeps. If necessary, increase the "Sweep/Average Count" in the "Sweep Config" dialog box.
 - Configure markers and delta markers to determine deviations and offsets within the results, e.g. when comparing errors or peaks.
12. Start a new sweep with the defined settings.

In MSRA mode you may want to stop the continuous measurement mode by the Sequencer and perform a single data acquisition:

- a) Select the Sequencer icon (🔴) from the toolbar.
- b) Set the Sequencer state to "OFF".
- c) Press [RUN SINGLE].

To define or edit a channel table

Channel tables contain a list of channels to be detected and their specific parameters. You can create user-defined and edit pre-defined channel tables.

1. Select "Channel Detection" from the main "Code Domain Analyzer" menu to open the "Channel Detection" dialog box.
2. To define a new channel table, select "New" next to the "Predefined Tables" list.
To edit an existing channel table:
 - a) Select the existing channel table in the "Predefined Tables" list.
 - b) Select "Edit" next to the "Predefined Tables" list.
3. In the "Channel Table" dialog box, define a name and, optionally, a comment that describes the channel table. The comment is displayed when you set the focus on the table in the "Predefined Tables" list.
4. Define the channels to be detected using one of the following methods:
Select "Measure Table" to create a table that consists of the channels detected in the currently measured signal.
Or:
 - a) Select "Add Channel" to insert a row for a new channel below the currently selected row in the channel table.
 - b) Define the channel specifications required for detection:
 - Symbol rate
 - Channel number
 - Whether TFCI is used
 - Timing offset, if applicable
 - Number of pilot bits (for DPCCH only)
 - The channel's code domain power (relative to the total signal power)
5. Select "Save Table" to store the channel table.
The table is stored and the dialog box is closed. The new channel table is included in the "Predefined Tables" list in the "Channel Detection" dialog box.
6. To activate the use of the new channel table:
 - a) Select the table in the "Predefined Tables" list.
 - b) Select "Select".
A checkmark is displayed next to the selected table.
 - c) Toggle the "Use Predefined Channel Table" setting to "Predefined".
 - d) Toggle the "Compare Meas Signal with Predefined Table" setting to "On".
 - e) Start a new measurement.

To determine the "Time Alignment Error"

1. Press [MODE] and select the "3GPP FDD BTS" applications for base station tests, or "3GPP FDD UE" for user equipment tests.

Code Domain Analysis of the input signal is performed by default.

2. Press "Synch." to display the "Synchronization" dialog box. Configure the location of the S-CPICH for antenna 2 and select the "Antenna Pattern".
3. Select the "Time Alignment Error" measurement:
 - a) Press [MEAS].
 - b) In the "Select Measurement" dialog box, select "Time Alignment Error".

The "Time Alignment Error" is calculated and displayed immediately.

To determine the "Time Alignment Error" for multiple carriers

1. Press [MODE] and select the "3GPP FDD BTS" application for base station tests.

Code Domain Analysis of the input signal is performed by default.

2. Select the "Time Alignment Error" measurement:
 - a) Press [MEAS].
 - b) In the "Select Measurement" dialog box, select "Time Alignment Error".
3. Select Carrier Table and define up to 4 carriers to be included in the measurement:
 - a) Define the reference carrier first. Its frequency is set to the center frequency.
 - b) Define the frequencies of all other carriers as an offset to the reference carrier.
 - c) Define the required synchronization information for the carriers.
 - d) Save the table.

The "Time Alignment Error" is calculated and the results for each carrier are displayed immediately.

To perform an RF measurement

1. Press [MODE] and select the "3GPP FDD BTS" applications for base station tests, or "3GPP FDD UE" for user equipment tests.

The FSW opens a new measurement channel for the 3GPP FDD application. Code Domain Analysis of the input signal is performed by default.

2. Select the RF measurement:
 - a) Press [MEAS].
 - b) In the "Select Measurement" dialog box, select the required measurement.

The selected measurement is activated with the default settings for the 3GPP FDD application immediately.

3. If necessary, adapt the settings as described for the individual measurements in the FSW User Manual.
4. Select "Display Config" and select the evaluation methods that are of interest to you.

Arrange them on the display to suit your preferences.

5. Exit the SmartGrid mode and select "Overview" to display the "Overview" again.
6. Select "Analysis" in the "Overview" to make use of the advanced analysis functions in the result displays.
 - Configure a trace to display the average over a series of sweeps; if necessary, increase the "Sweep Count" in the "Sweep" settings.
 - Configure markers and delta markers to determine deviations and offsets within the evaluated signal.
 - Use special marker functions to calculate noise or a peak list.
 - Configure a limit check to detect excessive deviations.
7. Optionally, export the trace data of the graphical evaluation results to a file.
 - a) In the "Traces" tab of the "Analysis" dialog box, switch to the "Trace Export" tab.
 - b) Select "Export Trace to ASCII File".
 - c) Define a file name and storage location and select "OK".

To select the application data for MSRA measurements

In multi-standard radio analysis you can analyze the data captured by the MSRA primary in the secondary 3GPP FDD BTS application. Assuming you have detected a suspect area of the captured data in another application, you would now like to analyze the same data in the 3GPP FDD BTS application.

1. Select "Overview" to display the "Overview" for Code Domain Analysis.
2. Select "Signal Capture".
3. Define the application data range as the "Capture Length (Frames)". You must determine the number of frames according to the following formula:

$$\langle \text{No of frames} \rangle = \langle \text{measurement time in seconds} \rangle / 10 \text{ ms (time per frame)}$$
 Add an additional frame as the first frame may start before the suspect measurement range.
4. Define the starting point of the application data as the "Capture offset". The offset is calculated according to the following formula:

$$\langle \text{capture offset} \rangle = \langle \text{starting point for application} \rangle - \langle \text{starting point in capture buffer} \rangle$$
5. The analysis interval is automatically determined according to the selected channel, slot or frame to analyze (defined for the evaluation range), depending on the result display. Note that the frame/slot/channel is analyzed *within the application data*. If the analysis interval does not yet show the required area of the capture buffer, move through the frames/slots/channels in the evaluation range or correct the application data range.
6. If the Sequencer is off, select "Refresh" in the "Sweep" menu to update the result displays for the changed application data.

10 Measurement examples

Some practical examples for basic 3GPP[®]FDD Base station tests are provided here. They describe how operating and measurement errors can be avoided using correct presets. The measurements are performed with an FSW equipped with option FSW-K72.

Key settings are shown as examples to avoid measurement errors. Following the correct setting, the effect of an incorrect setting is shown.

The measurements are performed using the following instruments and accessories:

- The FSW with Application Firmware FSW-K72: 3GPP FDD BTS (base station test)
- The Vector Signal Generator R&S SMW100A with option R&S SMW-K42: digital standard 3GPP FDD (requires options R&S SMW-B10, R&S SMW-B13 and R&S SMW-B103)
- 1 coaxial cable, 50Ω, approx. 1 m, N connector
- 1 coaxial cable, 50Ω, approx. 1 m, BNC connector

The following measurements are described:

- [Measurement 1: measuring the signal channel power](#)..... 136
- [Measurement 2: determining the spectrum emission mask](#)..... 137
- [Measurement 3: measuring the relative code domain power](#)..... 139
- [Measurement 4: triggered measurement of relative code domain power](#)..... 143
- [Measurement 5: measuring the composite EVM](#)..... 145
- [Measurement 6: determining the peak code domain error](#)..... 146

10.1 Measurement 1: measuring the signal channel power

The measurement of the spectrum gives an overview of the 3GPP FDD BTS signal and the spurious emissions close to the carrier.

Test setup

- ▶ Connect the RF output of the R&S SMW200A to the RF input of the FSW (coaxial cable with N connectors).

Settings on the R&S SMW200A

1. PRESET
2. "FREQ" = 2.1175 GHz
3. "LEVEL" = 0 dBm
4. "BASEBAND A > CDMA Standards > 3GPP FDD"
5. "General" tab: "LINK DIRECTION > DOWN/FORWARD"
6. "Base station" tab: "TEST MODELS > Test_Model_1_16_channels"

Measurement 2: determining the spectrum emission mask

7. "Base station" tab: "Select Base station > BS 1 > ON"
8. "General" tab: "3GPP FDD > STATE > ON"

Settings on the FSW

1. PRESET
2. "MODE > 3GPP FDD BTS"
3. "AMPT > Reference level" = 0 dBm
4. "FREQ > Center frequency" = 2.1175 GHz
5. "MEAS > POWER"
6. "AMPT > Scale Config > Auto Scale Once"

Result

Figure 10-1: Measurement Example 1: Measuring the Signal Channel Power

10.2 Measurement 2: determining the spectrum emission mask

The 3GPP specification defines a measurement which monitors the compliance with a spectral mask in a range of at least ± 12.5 MHz around the 3GPP FDD BTS carrier. To assess the power emissions in the specified range, the signal power is measured in the range near the carrier using a 30kHz filter, in the ranges far away from the carrier using a 1MHz filter. The resulting trace is compared to a limit line defined in the 3GPP specification.

Measurement 2: determining the spectrum emission mask

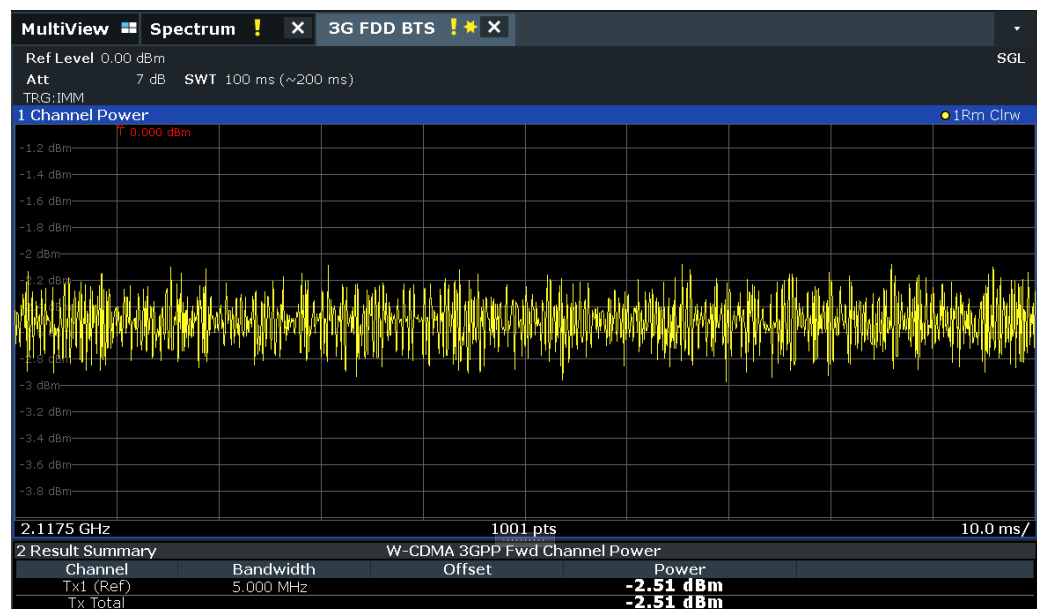
Test setup

- ▶ Connect the RF output of the R&S SMW200A to the RF input of the FSW (coaxial cable with N connectors).

Settings on the R&S SMW200A

1. PRESET
2. "FREQ" = 2.1175 GHz
3. "LEVEL" = 0 dBm
4. "DIGITAL STD" = "WCDMA/3GPP"
5. "DIGITAL STD > Set Default"
6. "DIGITAL STD > LINK DIRECTION > DOWN/FORWARD"
7. "DIGITAL STD > TEST MODELS > Test_Model_1_16_channels"
8. "DIGITAL STD > Select Base station > UE 1" = "ON"
9. "DIGITAL STD > WCDMA/3GPP > STATE" = "ON"

Settings on the FSW

1. PRESET
2. "MODE > 3GPP FDD BTS"
3. "AMPT > Reference level" = 0 dBm
4. "FREQ > Center frequency" = 2.1175 GHz
5. "MEAS > Spectrum Emission Mask"
6. "AMPT > Scale Config > Auto Scale Once"

Result

The following results are displayed:

- Spectrum of the 3GPP FDD BTS signal
- Limit line defined in the standard
- Information on limit line violations (passed/failed)

Measurement 3: measuring the relative code domain power

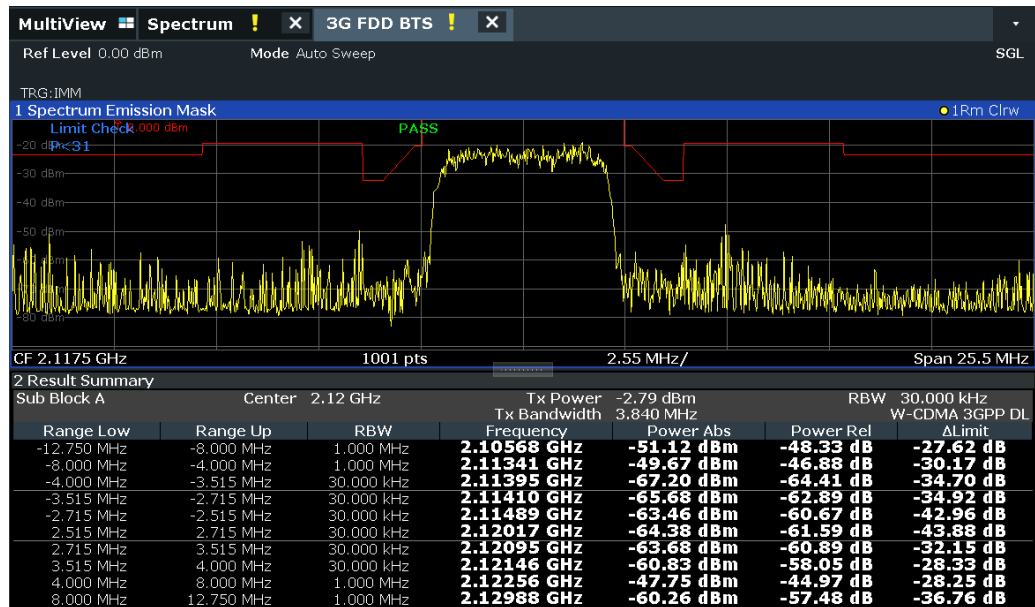

Figure 10-2: Measurement Example 2: Determining the Spectrum Emission Mask

10.3 Measurement 3: measuring the relative code domain power

A code domain power measurement on one of the channel configurations is shown in the following. Basic parameters of CDP analysis are changed to demonstrate the effects of values that are not adapted to the input signal.

Test setup

1. Connect the RF output of the R&S SMW200A to the RF input of the FSW (coaxial cable with N connectors).
2. Connect the reference input ([REF INPUT]) on the rear panel of the FSW to the reference output (REF) on the rear panel of R&S SMW200A (coaxial cable with BNC connectors).

Settings on the R&S SMW200A

1. PRESET
2. "FREQ" = 2.1175 GHz
3. "LEVEL" = 0 dBm
4. "BASEBAND A > CDMA Standards > 3GPP FDD"
5. "General" tab: "LINK DIRECTION > DOWN/FORWARD"
6. "Base station" tab: "TEST MODELS > Test_Model_1_16_channels"

Measurement 3: measuring the relative code domain power

7. "Base station" tab: "Select Base station > BS 1 > ON"
8. "General" tab: "3GPP FDD > STATE > ON"

Settings on the FSW

1. PRESET
2. "MODE > 3GPP FDD BTS"
3. "AMPT > Reference level"= 10 dBm
4. "FREQ > Center frequency" = 2.1175 GHz
5. "AMPT > Scale Config > Auto Scale Once"

Result

Window 1 shows the code domain power of the signal, on the Q branch.

Window 2 shows the result summary, i.e. the numeric results of the CDP measurement.

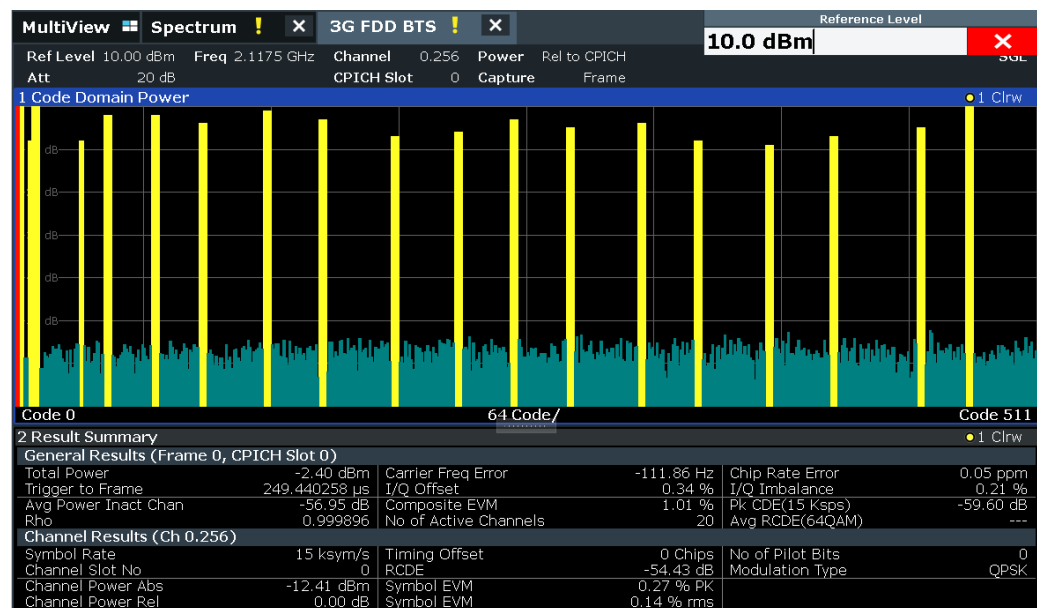

Figure 10-3: Measurement Example 3: Measuring the Relative Code Domain Power

10.3.1 Synchronizing the reference frequencies

The synchronization of the reference oscillators both of the DUT and FSW strongly reduces the measured frequency error.

Measurement 3: measuring the relative code domain power

Test setup

- ▶ Connect the reference input ([REF INPUT (1...20 MHz)]) on the rear panel of the FSW to the reference output (REF) on the rear panel of R&S SMW200A (coaxial cable with BNC connectors).

Settings on the R&S SMW200A

The settings on the R&S SMW200A remain the same.

Settings on the FSW

In addition to the settings of the basic test, activate the use of an external reference:

- ▶ "SETUP > Reference > Reference Frequency Input = External Reference 10 MHz"
The displayed carrier frequency error should be < 10 Hz.

10.3.2 Behavior with deviating center frequency

In the following, the behavior of the DUT and the FSW with an incorrect center frequency setting is shown.

1. Tune the center frequency of the signal generator in 0.5 kHz steps.
2. Watch the measurement results on the FSW screen:
 - Up to 3 kHz, a frequency error causes no apparent difference in measurement accuracy of the code domain power measurement.
 - Above a frequency error of 3 kHz, the probability of an impaired synchronization increases. With continuous measurements, at times all channels are displayed in blue with almost the same level.
 - Above a frequency error of approx. 7 kHz, a CDP measurement cannot be performed. The FSW displays all possible codes in blue with a similar level.
3. Reset the frequency to 2.1175 GHz both on the R&S SMW200A and on the FSW.

Measurement 3: measuring the relative code domain power

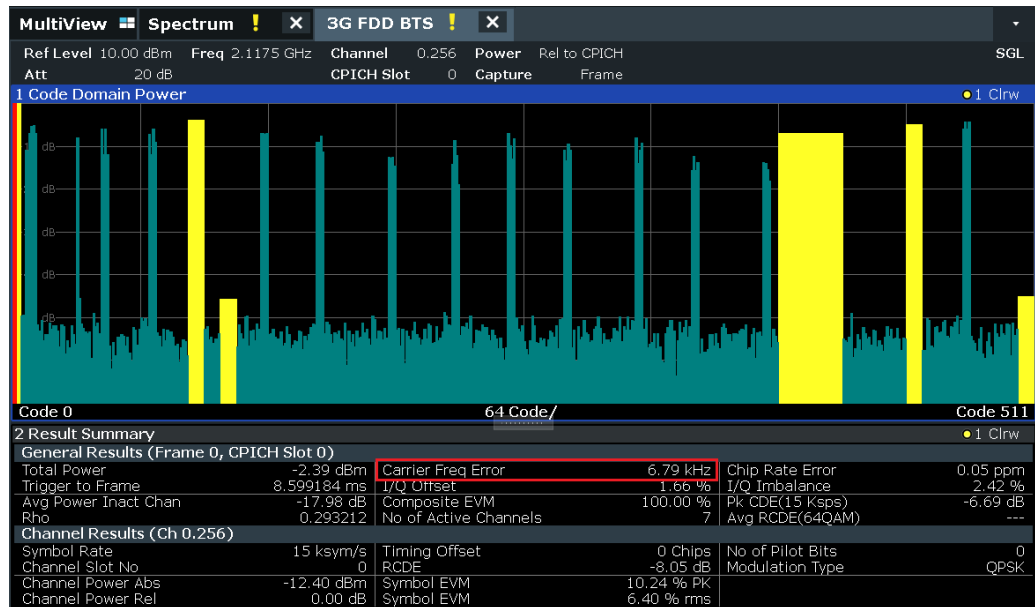

Figure 10-4: Measurement Example 3: Measuring the Relative Code Domain Power with Incorrect Center Frequency

10.3.3 Behavior with incorrect scrambling code

A valid CDP measurement can be carried out only if the scrambling code set on the FSW is identical to that of the transmitted signal.

Settings on the R&S SMW200A

- "Base stations" tab > BS 1 > "Common" tab: "SCRAMBLING CODE" = 0000

Settings on the FSW

- "Meas Config > Signal Description > Scrambling Code" = 0001

Result

The CDP display shows all possible codes with approximately the same level.

Measurement 4: triggered measurement of relative code domain power

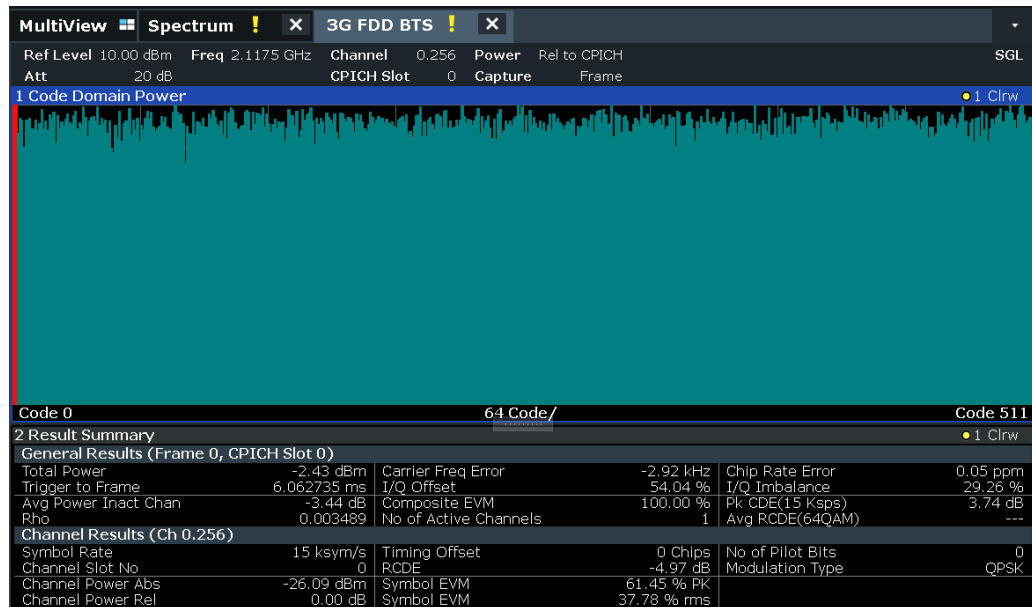

Figure 10-5: Measurement Example 3: Measuring the Relative Code Domain Power with Incorrect Scrambling Code

10.4 Measurement 4: triggered measurement of relative code domain power

If the code domain power measurement is performed without external triggering, a section of approximately 20 ms of the test signal is recorded at an arbitrary moment to detect the start of a 3GPP FDD BTS frame in this section. Depending on the position of the frame start, the required computing time can be quite long. Applying an external (frame) trigger can reduce the computing time.

Test setup

1. Connect the RF output of the R&S SMW200A to the input of the FSW.
2. Connect the reference input ([REF INPUT]) on the rear panel of the FSW to the reference input (REF) on the rear panel of the R&S SMW200A (coaxial cable with BNC connectors).
3. Connect the external trigger input of the FSW ([TRIGGER INPUT]) to the external trigger output of the R&S SMW200A (TRIGOUT1 of PAR DATA).

Settings on the R&S SMW200A

1. PRESET
2. "FREQ" = 2.1175 GHz
3. "LEVEL" = 0 dBm

Measurement 4: triggered measurement of relative code domain power

4. "BASEBAND A > CDMA Standards > 3GPP FDD"
5. "General" tab: "LINK DIRECTION > DOWN/FORWARD"
6. "Base station" tab: "TEST MODELS > Test_Model_1_16_channels"
7. "Base station" tab: "Select Base station > BS 1 > ON"
8. "General" tab: "3GPP FDD > STATE > ON"

Settings on the FSW

1. PRESET
2. "MODE > 3GPP FDD BTS"
3. "AMPT > Reference level" = 10 dBm
4. "FREQ > Center frequency" = 2.1175 GHz
5. "Meas Config > Signal Description > Scrambling Code" = 0000
6. "TRIG > External Trigger 1"
7. "AMPT > Scale Config > Auto Scale Once"

Results

The following is displayed:

- Window 1: Code domain power of signal
- Window 2: Result summary, including the Trigger to Frame, i.e. offset between trigger event and start of 3GPP FDD BTS frame

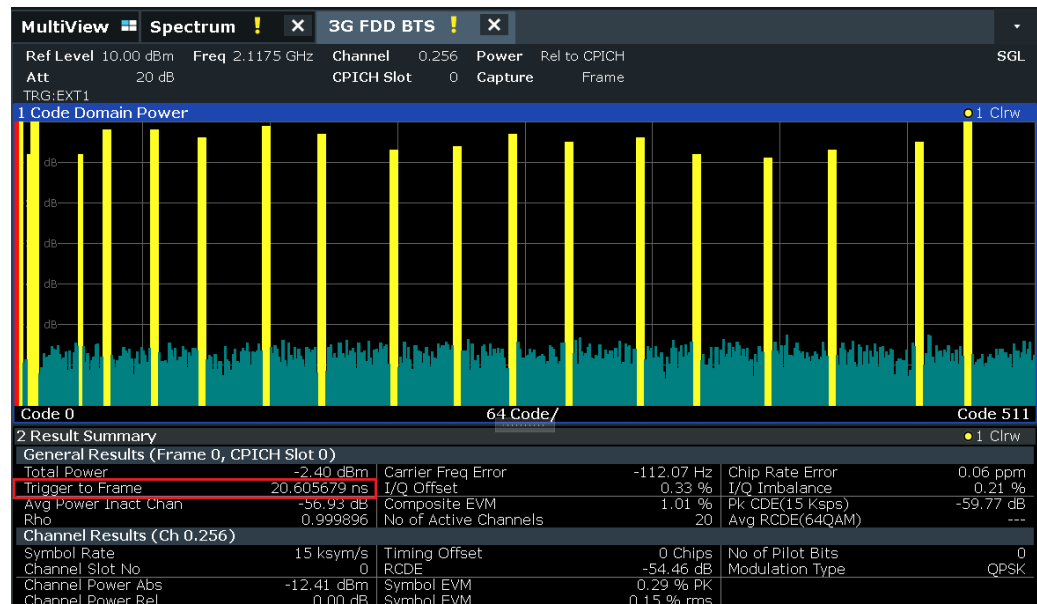

Figure 10-6: Measurement Example 4: Triggered Measurement of Relative Code Domain Power



The repetition rate of the measurement increases considerably compared to the repetition rate of a measurement without an external trigger.

Trigger Offset

A delay of the trigger event referenced to the start of the 3GPP FDD BTS frame can be compensated by modifying the trigger offset.

- ▶ Setting on the FSW:
"TRIG > Trigger Offset" = 100 μ s

The "Trigger to Frame" parameter in the "Result Summary" (Window 2) changes:
"Trigger to Frame" = -100 μ s

10.5 Measurement 5: measuring the composite EVM

The 3GPP specification defines the composite EVM measurement as the average square deviation of the total signal.

An ideal reference signal is generated from the demodulated data. The test signal and the reference signal are compared with each other. The square deviation yields the composite EVM.

Test setup

1. Connect the RF output of the R&S SMW200A to the input of the FSW.
2. Connect the reference input ([REF INPUT]) on the rear panel of the FSW to the reference input (REF) on the rear panel of the R&S SMW200A (coaxial cable with BNC connectors).
3. Connect the external trigger input of the FSW ([TRIGGER INPUT]) to the external trigger output of the R&S SMW200A (TRIGOUT1 of PAR DATA).

Settings on the R&S SMW200A

1. PRESET
2. "FREQ" = 2.1175 GHz
3. "LEVEL" = 0 dBm
4. "BASEBAND A > CDMA Standards > 3GPP FDD"
5. "General" tab: "LINK DIRECTION > DOWN/FORWARD"
6. "Base station" tab: "TEST MODELS > Test_Model_1_16_channels"
7. "Base station" tab: "Select Base station > BS 1 > ON"
8. "General" tab: "3GPP FDD > STATE > ON"

Measurement 6: determining the peak code domain error

Settings on the FSW

1. PRESET
2. "MODE > 3GPP FDD BTS"
3. "AMPT > Reference level" = 10 dBm
4. "FREQ > Center frequency" = 2.1175 GHz
5. "TRIG > External Trigger 1"
6. "MEAS CONFIG > Display Config > Composite EVM" (Window 2)
7. "AMPT > Scale Config > Auto Scale Once"

Results

The following is displayed:

- Window 1: Code domain power of signal
- Window 2: "Composite EVM" (EVM for total signal)

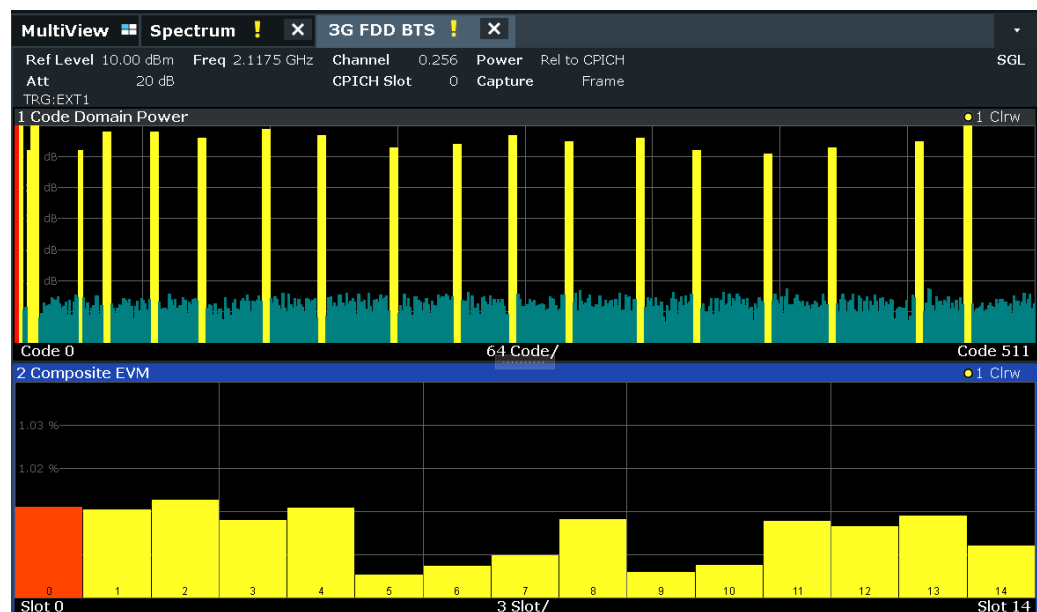

Figure 10-7: Measurement Example 5: Measuring the Composite EVM

10.6 Measurement 6: determining the peak code domain error

The peak code domain error measurement is defined in the 3GPP specification for FDD signals.

An ideal reference signal is generated from the demodulated data. The test signal and the reference signal are compared with each other. The difference of the two signals is

Measurement 6: determining the peak code domain error

projected onto the classes of the different spreading factors. The peak code domain error measurement is obtained by summing up the symbols of each difference signal slot and searching for the maximum error code.

Test setup

1. Connect the RF output of the R&S SMW200A to the input of the FSW.
2. Connect the reference input ([REF INPUT]) on the rear panel of the FSW to the reference input (REF) on the rear panel of the R&S SMW200A (coaxial cable with BNC connectors).
3. Connect the external trigger input of the FSW ([TRIGGER INPUT]) to the external trigger output of the R&S SMW200A (TRIGOUT1 of PAR DATA).

Settings on the R&S SMW200A

1. PRESET
2. "FREQ" = *2.1175 GHz*
3. "LEVEL" = *0 dBm*
4. "BASEBAND A > CDMA Standards > 3GPP FDD"
5. "General" tab: "LINK DIRECTION > DOWN/FORWARD"
6. "Base station" tab: "TEST MODELS > Test_Model_1_16_channels"
7. "Base station" tab: "Select Base station > BS 1 > ON"
8. "General" tab: "3GPP FDD > STATE > ON"

Settings on the FSW

1. PRESET
2. "MODE > 3GPP FDD BTS"
3. "AMPT > Reference level" = *0 dBm*
4. "FREQ > Center frequency" = *2.1175 GHz*
5. "TRIG > External Trigger 1"
6. "MEAS CONFIG > Display Config > Peak Code Domain Error" (Window 2)
7. "AMPT > Scale Config > Auto Scale Once"

Results

The following is displayed:

- Window 1: Code domain power of signal
- Window 2: Peak code domain error (projection of error onto the class with spreading factor 256)

Measurement 6: determining the peak code domain error



Figure 10-8: Measurement Example 6: Determining the Peak Code Domain Error

11 Remote commands for 3GPP FDD measurements

The following commands are required to perform measurements in 3GPP FDD applications in a remote environment.

It is assumed that the FSW has already been set up for remote control in a network as described in the FSW User Manual.



Note that basic tasks that are also performed in the base unit in the same way are not described here. For a description of such tasks, see the FSW User Manual.

In particular, this includes:

- Managing Settings and Results, i.e. storing and loading settings and result data
- Basic instrument configuration, e.g. checking the system configuration, customizing the screen layout, or configuring networks and remote operation
- Using the common status registers



SCPI Recorder - automating tasks with remote command scripts

The R&S FSW 3GPP FDD Measurements application also supports the SCPI Recorder functionality.

Using the SCPI Recorder functions, you can create a SCPI script directly on the instrument and then export the script for use on the controller. You can also edit or write a script manually, using a suitable editor on the controller. For manual creation, the instrument supports you by showing the corresponding command syntax for the current setting value.

For details see the "Network and Remote Operation" chapter in the FSW User Manual.

The following topics specific to 3GPP applications are described here:

• Introduction	150
• Common suffixes	154
• Activating 3GPP FDD measurements	155
• Selecting a measurement	159
• Configuring code domain analysis and time alignment error measurements	161
• Configuring RF measurements	232
• Configuring the result display	233
• Starting a measurement	242
• Retrieving results	246
• Analysis	273
• Importing and exporting I/Q data and results	284
• Configuring the secondary application data range (MSRA mode only)	286
• Querying the status registers	288
• Deprecated commands	291
• Programming examples (FSW-k72)	295

11.1 Introduction

Commands are program messages that a controller (e.g. a PC) sends to the instrument or software. They operate its functions ('setting commands' or 'events') and request information ('query commands'). Some commands can only be used in one way, others work in two ways (setting and query). If not indicated otherwise, the commands can be used for settings and queries.

The syntax of a SCPI command consists of a header and, usually, one or more parameters. To use a command as a query, you have to append a question mark after the last header element, even if the command contains a parameter.

A header contains one or more keywords, separated by a colon. Header and parameters are separated by a "white space" (ASCII code 0 to 9, 11 to 32 decimal, e.g. blank). If there is more than one parameter for a command, they are separated by a comma from one another.

Only the most important characteristics that you need to know when working with SCPI commands are described here. For a more complete description, refer to the user manual of the FSW.



Remote command examples

Note that some remote command examples mentioned in this general introduction are possibly not supported by this particular application.

11.1.1 Conventions used in descriptions

The following conventions are used in the remote command descriptions:

- *Command usage*
If not specified otherwise, commands can be used both for setting and for querying parameters.
If a command can be used for setting or querying only, or if it initiates an event, the usage is stated explicitly.
- *Parameter usage*
If not specified otherwise, a parameter can be used to set a value, and it is the result of a query.
Parameters required only for setting are indicated as "Setting parameters".
Parameters required only to refine a query are indicated as "Query parameters".
Parameters that are only returned as the result of a query are indicated as "Return values".
- *Conformity*
Commands that are taken from the SCPI standard are indicated as "SCPI confirmed". All commands used by the FSW follow the SCPI syntax rules.
- *Asynchronous commands*
A command which does not automatically finish executing before the next command starts executing (overlapping command) is indicated as an "Asynchronous command".
- *Reset values (*RST)*

Default parameter values that are used directly after resetting the instrument (*RST command) are indicated as "**RST" values, if available.

- *Default unit*
The default unit is used for numeric values if no other unit is provided with the parameter.
- *Manual operation*
If the result of a remote command can also be achieved in manual operation, a link to the description is inserted.

11.1.2 Long and short form

The keywords have a long and a short form. You can use either the long or the short form, but no other abbreviations of the keywords.

The short form is emphasized in uppercase letters. Note however, that this emphasis only serves the purpose to distinguish the short from the long form in the manual. For the instrument, the case does not matter.

Example:

`SENSe:FREQUency:CENTer` is the same as `SENS:FREQ:CENT`.

11.1.3 Numeric suffixes

Some keywords have a numeric suffix if the command can be applied to multiple instances of an object. In that case, the suffix selects a particular instance (e.g. a measurement window).

Numeric suffixes are indicated by angular brackets (<n>) next to the keyword.

If you do not quote a suffix for keywords that support one, a 1 is assumed.

Example:

`DISPlay[:WINDow<1...4>]:ZOOM:STATe` enables the zoom in a particular measurement window, selected by the suffix at `WINDow`.

`DISPlay:WINDow4:ZOOM:STATe ON` refers to window 4.

11.1.4 Optional keywords

Some keywords are optional and are only part of the syntax because of SCPI compliance. You can include them in the header or not.



If an optional keyword has a numeric suffix and you need to use the suffix, you have to include the optional keyword. Otherwise, the suffix of the missing keyword is assumed to be the value 1.

Optional keywords are emphasized with square brackets.

Example:

Without a numeric suffix in the optional keyword:

```
[SENSe:]FREQuency:CENTer is the same as FREQuency:CENTer
```

With a numeric suffix in the optional keyword:

```
DISPlay[:WINDow<1...4>]:ZOOM:STATe
```

DISPlay:ZOOM:STATe ON enables the zoom in window 1 (no suffix).

DISPlay:WINDow4:ZOOM:STATe ON enables the zoom in window 4.

11.1.5 Alternative keywords

A vertical stroke indicates alternatives for a specific keyword. You can use both keywords to the same effect.

Example:

```
[SENSe:]BANDwidth|BWIDth[:RESolution]
```

In the short form without optional keywords, BAND 1MHZ would have the same effect as BWID 1MHZ.

11.1.6 SCPI parameters

Many commands feature one or more parameters.

If a command supports more than one parameter, they are separated by a comma.

Example:

```
LAYout:ADD:WINDow Spectrum,LEFT,MTABLE
```

Parameters can have different forms of values.

- [Numeric values](#)..... 152
- [Boolean](#)..... 153
- [Character data](#)..... 154
- [Character strings](#)..... 154
- [Block data](#)..... 154

11.1.6.1 Numeric values

Numeric values can be entered in any form, i.e. with sign, decimal point or exponent. For physical quantities, you can also add the unit. If the unit is missing, the command uses the basic unit.

Example:

With unit: SENSe:FREQuency:CENTer 1GHZ

Without unit: SENSe:FREQuency:CENTer 1E9 would also set a frequency of 1 GHz.

Values exceeding the resolution of the instrument are rounded up or down.

If the number you have entered is not supported (e.g. for discrete steps), the command returns an error.

Instead of a number, you can also set numeric values with a text parameter in special cases.

- **MIN/MAX**
Defines the minimum or maximum numeric value that is supported.
- **DEF**
Defines the default value.
- **UP/DOWN**
Increases or decreases the numeric value by one step. The step size depends on the setting. Sometimes, you can customize the step size with a corresponding command.

Querying numeric values

When you query numeric values, the system returns a number. For physical quantities, it applies the basic unit (e.g. Hz for frequencies). The number of digits after the decimal point depends on the type of numeric value.

Example:

Setting: `SENSe:FREQuency:CENTer 1GHZ`

Query: `SENSe:FREQuency:CENTer?` would return `1E9`

Sometimes, numeric values are returned as text.

- **INF/NINF**
Infinity or negative infinity. Represents the numeric values `9.9E37` or `-9.9E37`.
- **NAN**
Not a number. Represents the numeric value `9.91E37`. NAN is returned if errors occur.

11.1.6.2 Boolean

Boolean parameters represent two states. The "on" state (logically true) is represented by "ON" or the numeric value 1. The "off" state (logically untrue) is represented by "OFF" or the numeric value 0.

Querying Boolean parameters

When you query Boolean parameters, the system returns either the value 1 ("ON") or the value 0 ("OFF").

Example:

Setting: `DISPlay:WINDow:ZOOM:STATe ON`

Query: `DISPlay:WINDow:ZOOM:STATe?` would return `1`

11.1.6.3 Character data

Character data follows the syntactic rules of keywords. You can enter text using a short or a long form. For more information, see [Chapter 11.1.2, "Long and short form"](#), on page 151.

Querying text parameters

When you query text parameters, the system returns its short form.

Example:

Setting: `SENSe:BANDwidth:RESolution:TYPE NORMAl`

Query: `SENSe:BANDwidth:RESolution:TYPE?` would return `NORM`

11.1.6.4 Character strings

Strings are alphanumeric characters. They have to be in straight quotation marks. You can use a single quotation mark (') or a double quotation mark (").

Example:

`INSTRument:DELeTe 'Spectrum'`

11.1.6.5 Block data

Block data is a format which is suitable for the transmission of large amounts of data.

The ASCII character # introduces the data block. The next number indicates how many of the following digits describe the length of the data block. The data bytes follow. During the transmission of these data bytes, all end or other control signs are ignored until all bytes are transmitted. #0 specifies a data block of indefinite length. The use of the indefinite format requires an `NL^END` message to terminate the data block. This format is useful when the length of the transmission is not known or if speed or other considerations prevent segmentation of the data into blocks of definite length.

11.2 Common suffixes

In the R&S FSW 3GPP FDD Measurements application, the following common suffixes are used in remote commands:

Table 11-1: Common suffixes used in remote commands in the R&S FSW 3GPP FDD Measurements application

Suffix	Value range	Description
<m>	1 to 4 (RF: 1 to 16)	Marker
<n>	1 to 16	Window (in the currently selected channel)

Suffix	Value range	Description
<t>	1 (RF: 1 to 6)	Trace
	1 to 8	Limit line

11.3 Activating 3GPP FDD measurements

3GPP FDD measurements require a special application on the FSW. The measurement is started immediately with the default settings.

INSTrument:CREate:DUPLicate	155
INSTrument:CREate[:NEW]	155
INSTrument:CREate:REPLace	156
INSTrument:DELeTe	156
INSTrument:LIST?	156
INSTrument:REName	158
INSTrument[:SELeCt]	158
SYSTem:PRESet:CHANnel[:EXEC]	159

INSTrument:CREate:DUPLicate

Duplicates the currently selected channel, i.e. creates a new channel of the same type and with the identical measurement settings. The name of the new channel is the same as the copied channel, extended by a consecutive number (e.g. "IQAnalyzer" -> "IQAnalyzer 2").

The channel to be duplicated must be selected first using the `INST:SEL` command.

Is not available if the MSRA primary channel is selected.

Example:

```
INST:SEL 'IQAnalyzer'
```

```
INST:CRE:DUPL
```

Duplicates the channel named 'IQAnalyzer' and creates a new channel named 'IQAnalyzer2'.

Usage: Event

INSTrument:CREate[:NEW] <ChannelType>, <ChannelName>

Adds a measurement channel. You can configure up to 10 measurement channels at the same time (depending on available memory).

Parameters:

<ChannelType> Channel type of the new channel.
For a list of available channel types, see [INSTrument:LIST?](#) on page 156.

<ChannelName> String containing the name of the channel.
Note that you cannot assign an existing channel name to a new channel. If you do, an error occurs.

Example: `INST:CRE SAN, 'Spectrum 2'`
Adds a spectrum display named "Spectrum 2".

INSTrument:CREate:REPLace <ChannelName1>, <ChannelType>, <ChannelName2>

Replaces a channel with another one.

Setting parameters:

<ChannelName1> String containing the name of the channel you want to replace.

<ChannelType> Channel type of the new channel.
For a list of available channel types, see [INSTrument:LIST?](#) on page 156.

<ChannelName2> String containing the name of the new channel.
Note: If the specified name for a new channel already exists, the default name, extended by a sequential number, is used for the new channel (see [INSTrument:LIST?](#) on page 156).
Channel names can have a maximum of 31 characters, and must be compatible with the Windows conventions for file names. In particular, they must not contain special characters such as ":", "*", "?".

Example: `INST:CRE:REPL 'IQAnalyzer2', IQ, 'IQAnalyzer'`
Replaces the channel named "IQAnalyzer2" by a new channel of type "IQ Analyzer" named "IQAnalyzer".

Usage: Setting only

INSTrument:DELeTe <ChannelName>

Deletes a channel.

If you delete the last channel, the default "Spectrum" channel is activated.

Setting parameters:

<ChannelName> String containing the name of the channel you want to delete.
A channel must exist to delete it.

Example: `INST:DEL 'IQAnalyzer4'`
Deletes the channel with the name 'IQAnalyzer4'.

Usage: Setting only

INSTrument:LIST?

Queries all active channels. The query is useful to obtain the names of the existing channels, which are required to replace or delete the channels.

Return values:

<ChannelType>
<ChannelName>

For each channel, the command returns the channel type and channel name (see tables below).

Tip: to change the channel name, use the `INSTRUMENT:REName` command.

Example:

```
INST:LIST?
```

Result for 3 channels:

```
'ADEM', 'Analog Demod', 'IQ', 'IQ Analyzer', 'IQ', 'IQ Analyzer2'
```

Usage:

Query only

Table 11-2: Available channel types and default channel names in Signal and Spectrum Analyzer mode

Application	<ChannelType> parameter	Default Channel name*)
Spectrum	SANALYZER	Spectrum
1xEV-DO BTS (R&S FSW-K84)	BDO	1xEV-DO BTS
1xEV-DO MS (R&S FSW-K85)	MDO	1xEV-DO MS
3GPP FDD BTS (R&S FSW-K72)	BWCD	3G FDD BTS
3GPP FDD UE (R&S FSW-K73)	MWCD	3G FDD UE
802.11ad (R&S FSW-K95)	WIGIG	802.11ad
802.11ay (R&S FSW-K97)	EDMG	802.11ay EDMG
Amplifier Measurements (R&S FSW-K18)	AMPLifier	Amplifier
AM/FM/PM Modulation Analysis (R&S FSW-K7)	ADEM	Analog Demod
Avionics (R&S FSW-K15)	AVIonics	Avionics
Bluetooth (R&S FSW-K8)	BTO	Bluetooth
cdma2000 BTS (R&S FSW-K82)	BC2K	CDMA2000 BTS
cdma2000 MS (R&S FSW-K83)	MC2K	CDMA2000 MS
DOCSIS 3.1 (R&S FSW-K192/193)	DOCSis	DOCSIS 3.1
Fast Spur Search (R&S FSW-K50)	SPUR	Spurious
GSM (R&S FSW-K10)	GSM	GSM
HRP UWB (R&S FSW-K149)	UWB	HRP UWB
I/Q Analyzer	IQ	IQ Analyzer
LTE (R&S FSW-K10x)	LTE	LTE
Multi-Carrier "Group Delay" (R&S FSW-K17)	MCGD	MC "Group Delay"
NB-IoT (R&S FSW-K106)	NIOT	NB-IoT
Noise (R&S FSW-K30)	NOISE	Noise
*) If the specified name for a new channel already exists, the default name, extended by a sequential number, is used for the new channel.		

Application	<ChannelType> parameter	Default Channel name*)
5G NR (R&S FSW-K144)	NR5G	5G NR
OFDM VSA (R&S FSW-K96)	OFDMVSA	OFDM VSA
OneWeb (R&S FSW-K201)	OWEB	OneWeb
Phase Noise (R&S FSW-K40)	PNOISE	Phase Noise
Pulse (R&S FSW-K6)	PULSE	Pulse
"Real-Time Spectrum"	RTIM	"Real-Time Spectrum"
TD-SCDMA BTS (R&S FSW-K76)	BTDS	TD-SCDMA BTS
TD-SCDMA UE (R&S FSW-K77)	MTDS	TD-SCDMA UE
Transient Analysis (R&S FSW-K60)	TA	Transient Analysis
Verizon 5GTF Measurement Application (V5GTF, R&S FSW-K118)	V5GT	V5GT
VSA (R&S FSW-K70)	DDEM	VSA
WLAN (R&S FSW-K91)	WLAN	WLAN
*) If the specified name for a new channel already exists, the default name, extended by a sequential number, is used for the new channel.		

INSTrument:REName <ChannelName1>, <ChannelName2>

Renames a channel.

Setting parameters:

<ChannelName1> String containing the name of the channel you want to rename.

<ChannelName2> String containing the new channel name.
 Note that you cannot assign an existing channel name to a new channel. If you do, an error occurs.
 Channel names can have a maximum of 31 characters, and must be compatible with the Windows conventions for file names. In particular, they must not contain special characters such as ":", "*", "?".

Example: `INST:REN 'IQAnalyzer2', 'IQAnalyzer3'`
 Renames the channel with the name 'IQAnalyzer2' to 'IQAnalyzer3'.

Usage: Setting only

INSTrument[:SElect] <ChannelType>

This command activates a new measurement channel with the defined channel type, or selects an existing measurement channel with the specified name.

See also [INSTrument:CREate\[:NEW\]](#) on page 155.

For a list of available channel types see [INSTrument:LIST?](#) on page 156.

Parameters:

<ChannelType> **BWCD**
 3GPP FDD BTS option, FSW-K72

MWCD
 3GPP FDD UE option, FSW-K73

SYSTem:PRESet:CHANnel[:EXEC]

Restores the default instrument settings in the current channel.

Use `INST:SEL` to select the channel.

Example:

```
INST:SEL 'Spectrum2'
Selects the channel for "Spectrum2".
SYST:PRESet:CHAN:EXEC
Restores the factory default settings to the "Spectrum2" channel.
```

Usage: Event

Manual operation: See "[Preset Channel](#)" on page 62

11.4 Selecting a measurement

The following commands are required to define the measurement type in a remote environment. For details on available measurements see [Chapter 3, "Measurements and result display"](#), on page 16.

CONFigure:WCDPower[:BTS]:MEASurement	159
CONFigure:WCDPower:MS:MEASurement	160

CONFigure:WCDPower[:BTS]:MEASurement <Type>

Selects the type of 3GPP FDD BTS base station tests.

Parameters:

<Type> ACLR | ESpectrum | WCDPower | POWER | OBANdwith |
 CCDF | RFCombi | TAERror

ACLR
 Adjacent-channel power measurement (standard 3GPP
 WCDMA Forward) with predefined settings

ESpectrum
 Measurement of spectrum emission mask

WCDPower
 Code domain power measurement. This selection has the same
 effect as command `INSTrument:SElect BWCD`

POWER
 Channel power measurement (standard 3GPP WCDMA For-
 ward) with predefined settings

OBANdwith | OBWidth

Measurement of occupied power bandwidth

CCDF

Measurement of complementary cumulative distribution function

RFCombi

Combined Adjacent Channel Power (Ch Power ACLR) measurement with "Occupied Bandwidth" and "Spectrum Emission Mask"

TAERror

"Time Alignment Error" measurement

*RST: WCDPower

Example:

CONF:WCDP:MEAS TAE

Mode:

BTS application only

Manual operation:

See "Time Alignment Error" on page 35

See "Channel Power ACLR" on page 36

See "Occupied Bandwidth" on page 36

See "Power" on page 36

See "RF Combi" on page 37

See "Spectrum Emission Mask" on page 38

See "CCDF" on page 39

CONFigure:WCDPower:MS:MEASurement <Type>

Selects the 3GPP FDD UE user equipment tests.

Parameters:

<Type>

ACLR | ESpectrum | WCDPower | POWER | OBANdwith | OBWidth | CCDF

ACLR

Adjacent-channel power measurement (standard 3GPP WCDMA Reverse) with predefined settings

ESpectrum

Measurement of spectrum emission mask

WCDPower

Code domain power measurement. This selection has the same effect as command INSTRUMENT:SElect MWCD

POWER

Channel power measurement (standard 3GPP WCDMA Reverse) with predefined settings

OBANdwith | OBWidth

Measurement of occupied power bandwidth.

CCDF

Measurement of complementary cumulative distribution function.

*RST: WCDPower

Example:

CONF:WCDP:MS:MEAS TAE

Mode: UE application only

11.5 Configuring code domain analysis and time alignment error measurements

The following commands are required to configure Code Domain Analysis and "Time Alignment Error" measurements.

• Signal description	161
• Configuring the data input and output	166
• Frontend configuration	187
• Configuring triggered measurements	196
• Signal capturing	203
• Synchronization	205
• Channel detection	206
• Sweep settings	218
• Automatic settings	219
• Evaluation range	223
• Code domain analysis settings (BTS measurements)	224
• Code domain analysis settings (UE measurements)	226
• Configuring carrier tables for time alignment measurements	227

11.5.1 Signal description

The signal description provides information on the expected input signal.

• BTS signal description	161
• BTS scrambling code	164
• UE signal description	165

11.5.1.1 BTS signal description

The following commands describe the input signal in BTS measurements.

[SENSe:]CDPower:ANTenna	161
[SENSe:]CDPower:HSDPamode	162
[SENSe:]CDPower:LCODE:SEARch[:IMMediate]	162
[SENSe:]CDPower:LCODE:SEARch:LIST	163
[SENSe:]CDPower:MIMO	163
[SENSe:]CDPower:PCONtrol	164

[SENSe:]CDPower:ANTenna <Mode>

Activates or deactivates the antenna diversity mode and selects the antenna to be used.

Parameters:

<Mode> *RST: OFF

Configuring code domain analysis and time alignment error measurements

Example:	CDP:ANT 1
Mode:	BTS application only
Manual operation:	See "Antenna Diversity" on page 64 See "Antenna Number" on page 64 See "Antenna1 / Antenna2" on page 90

[SENSe:]CDPower:HSDPamode <State>

Defines whether the HS-DPCCH channel is searched or not.

Parameters:

<State>	ON OFF 0 1
	ON 1
	The high speed channels can be detected. A detection of the modulation type (QPSK /16QAM) is done instead of a detection of pilot symbols.
	OFF 0
	The high speed channel can not be detected. A detection of pilot symbols is done instead a detection of the modulation type (QPSK /16QAM)
*RST:	1

Example: SENS:CDP:HSDP OFF

Manual operation: See "HSDPA/UPE" on page 63

[SENSe:]CDPower:LCODE:SEARch[:IMMediate]

Automatically searches for the scrambling codes that lead to the highest signal power. The code with the highest power is stored as the new scrambling code for further measurements.

Searching requires that the correct center frequency and level are set. The scrambling code search can automatically determine the primary scrambling code number. The secondary scrambling code number is expected as 0. Alternative scrambling codes can not be detected. Therefore the range for detection is 0x0000 – 0x1FF0h, where the last digit is always 0.

If the search is successful (PASS), a code was found and can be queried using [\[SENSe:\]CDPower:LCODE:SEARch:LIST](#).

Parameters:

<Status>	PASSed
	Scrambling code(s) found.
	FAILed
	No scrambling code found.

Example: SENS:CDP:LCODE:SEAR?
Searches the scrambling code that leads to the highest signal power and returns the status of the search.

Mode: BTS application only

Manual operation: See "[Autosearch for Scrambling Code](#)" on page 65

[SENSe:]CDPower:LCODE:SEARch:LIST

Returns the automatic search sequence (see [SENSe:]CDPower:LCODE:SEARch[:IMMediate] on page 162) as a comma-separated list of results for each detected scrambling code.

Parameters:

<Code1> Scrambling code in decimal format.

Range: $16 * n$, with $n = 0...511$

<Code2> Scrambling code in hexadecimal format.

Range: $0x0000h - 0x1FF0h$, where the last digit is always 0

<CPICHPower> Highest power value for the corresponding scrambling code.

Example: SENS:CDP:LCOD:SEAR:LIST?

Result:

16,0x10,-18.04,32,0x20,-22.87,48,0x30,-27.62,
64,0x40,-29.46

(Explanation in table below)

Mode: BTS application only

Manual operation: See "[Scrambling Codes](#)" on page 65

Table 11-3: Description of query results in example:

Code (dec)	Code(hex)	CPICH power (dBm)
16	0x10	-18.04
32	0x20	-22.87
48	0x30	-27.62
64	0x40	-29.46

[SENSe:]CDPower:MIMO <State>

Activates or deactivates single antenna MIMO measurement mode.

Channels that have modulation type MIMO-QPSK or MIMO-16QAM are only recognized as active channels if this setting is ON.

For details see "[MIMO](#)" on page 64.

Parameters:

<State> ON | OFF | 1 | 0

*RST: 0

Example: SENS:CDP:MIMO ON

Mode: BTS application only

Manual operation: See "MIMO" on page 64

[SENSe:]CDPower:PCONtrol <Position>

Determines the power control measurement position. An enhanced channel search is used to consider the properties of compressed mode channels.

Parameters:

<Position> SLOT | PILot

SLOT

The slot power is averaged from the beginning of the slot to the end of the slot.

PILot

The slot power is averaged from the beginning of the pilot symbols of the previous slot to the beginning of the pilot symbols of the current slot.

*RST: PILot

Example:

SENS:CDP:PCON SLOT

Switch to power averaging from slot start to the end of the slot. An enhanced channel search is used to consider the properties of compressed mode channels.

SENS:CDP:PCON PIL

Switch to power averaging from the pilot symbols of the previous slot number to the start of the pilots of the displayed slot number. The channel search only considers standard channels.

Mode: BTS application only

Manual operation: See "Compressed Mode" on page 64

11.5.1.2 BTS scrambling code

The scrambling code identifies the base station transmitting the signal in BTS measurements.

CONFigure:WCDPower[:BTS]:SCRambling:FORMat..... 164

[SENSe:]CDPower:LCODE:DVALue..... 164

[SENSe:]CDPower:LCODE[:VALue]..... 165

CONFigure:WCDPower[:BTS]:SCRambling:FORMat <Type>

Switches the format of the scrambling codes between hexadecimal and decimal.

Parameters:

<Type> DEC | HEX

[SENSe:]CDPower:LCODE:DVALue <ScramblingCode>

Defines the scrambling code in decimal format.

Configuring code domain analysis and time alignment error measurements

Parameters:

<ScramblingCode> *RST: 0

Example:

SENS:CDP:LCOD:DVAL 3

Defines the scrambling code in decimal format.

Manual operation:

See "[Scrambling Code](#)" on page 65

See "[Format Hex/Dec](#)" on page 65

See "[Format](#)" on page 67

[SENSe:]CDPower:LCODE[:VALue] <ScramblingCode>

Defines the scrambling code in hexadecimal format.

Parameters:

<ScramblingCode> Range: #H0 to #H1fff

*RST: #H0

Example:

SENS:CDP:LCOD #H2

Defines the scrambling code in hexadecimal format.

Manual operation:

See "[Format Hex/Dec](#)" on page 65

See "[Scrambling Code](#)" on page 66

11.5.1.3 UE signal description

The following commands describe the input signal in UE measurements.

Useful commands for describing UE signals described elsewhere:

- [\[SENSe:\]CDPower:LCODE\[:VALue\]](#) on page 165
- [\[SENSe:\]CDPower:HSDPamode](#) on page 162

Remote commands exclusive to describing UE signals:

[SENSe:]CDPower:LCODE:TYPE	165
[SENSe:]CDPower:QPSKonly	166
[SENSe:]CDPower:SFACTOR	166

[SENSe:]CDPower:LCODE:TYPE <Type>

Switches between long and short scrambling code.

Parameters:

<Type> LONG | SHORT

Example:

CDP:LCOD:TYPE SHOR

Mode:

UE application only

Manual operation:

See "[Type](#)" on page 67

Configuring code domain analysis and time alignment error measurements

[SENSe:]CDPower:QPSKOnly <State>

If enabled, it is assumed that the signal uses QPSK modulation only. Thus, no synchronization is required and the measurement can be performed with optimized settings and speed.

Parameters:

<State> ON | OFF | 1 | 0
*RST: 0

Mode: BTS application only

Manual operation: See "QPSK Modulation Only" on page 67

[SENSe:]CDPower:SFACTOR <SpreadingFactor>

Defines the spreading factor. The spreading factor is only significant for "Peak Code Domain Error" evaluation.

Parameters:

<SpreadingFactor> 4 | 8 | 16 | 32 | 64 | 128 | 256 | 512
*RST: 512

Example: SENS:CDP:SFACTOR 16

11.5.2 Configuring the data input and output

- [RF input](#).....166
- [Configuring file input](#).....170
- [Remote commands for the Digital Baseband interface \(FSW-B17\)](#).....172
- [Configuring input via the optional Analog Baseband interface](#).....179
- [Setting up probes](#).....181
- [Configuring the outputs](#).....186

11.5.2.1 RF input

INPut:ATTenuation:PROtection:RESet	167
INPut:CONNector	167
INPut:COUPling	167
INPut:DPATH	168
INPut:FILTer:HPASs[:STATe]	168
INPut:FILTer:YIG[:STATe]	168
INPut:IMPedance	169
INPut:SElect	169
INPut:TYPE	170

INPut:ATTenuation:PROTection:RESet

Resets the attenuator and reconnects the RF input with the input mixer for the FSW after an overload condition occurred and the protection mechanism intervened. The error status bit (bit 3 in the `STAT:QUES:POW` status register) and the `INPUT_OVLD` message in the status bar are cleared.

(For details on the status register see the FSW base unit user manual).

The command works only if the overload condition has been eliminated first.

Example: `INP:ATT:PROT:RES`

INPut:CONNector <ConnType>

Determines which connector the input for the measurement is taken from.

Parameters:

<ConnType>

RF

RF input connector

AIQI

Analog Baseband I connector

This setting is only available if the "Analog Baseband" interface (FSW-B71) is installed and active for input. It is not available for the FSW67 or FSW85.

For more information on the "Analog Baseband" interface (FSW-B71), see the FSW I/Q Analyzer and I/Q Input User Manual.

RFProbe

Active RF probe

*RST: RF

Example: `INP:CONN RF`
Selects input from the RF input connector.

Manual operation: See "[Input Connector](#)" on page 71

INPut:COUPling <CouplingType>

Selects the coupling type of the RF input.

The command is not available for measurements with the optional "Digital Baseband" interface.

Parameters:

<CouplingType>

AC | DC

AC

AC coupling

DC

DC coupling

*RST: AC

Example: `INP:COUP DC`

Manual operation: See ["Input Coupling"](#) on page 69

INPut:DPATH <DirectPath>

Enables or disables the use of the direct path for frequencies close to 0 Hz.

Parameters:

<DirectPath>

AUTO | OFF

AUTO | 1

(Default) the direct path is used automatically for frequencies close to 0 Hz.

OFF | 0

The analog mixer path is always used.

Example:

INP:DPAT OFF

Manual operation: See ["Direct Path"](#) on page 70

INPut:FILTer:HPASs[:STATe] <State>

Activates an additional internal high-pass filter for RF input signals from 1 GHz to 3 GHz. This filter is used to remove the harmonics of the FSW to measure the harmonics for a DUT, for example.

Requires an additional high-pass filter hardware option.

(Note: for RF input signals outside the specified range, the high-pass filter has no effect. For signals with a frequency of approximately 4 GHz upwards, the harmonics are suppressed sufficiently by the YIG-preselector, if available.)

Parameters:

<State>

ON | OFF | 0 | 1

OFF | 0

Switches the function off

ON | 1

Switches the function on

*RST: 0

Example:

INP:FILT:HPAS ON

Turns on the filter.

Manual operation: See ["High Pass Filter 1 to 3 GHz"](#) on page 70

INPut:FILTer:YIG[:STATe] <State>

Enables or disables the YIG filter.

Parameters:

<State>

ON | OFF | 0 | 1

Example:

INP:FILT:YIG OFF

Deactivates the YIG-preselector.

Manual operation: See ["YIG-Preselector"](#) on page 70

INPut:IMPedance <Impedance>

Selects the nominal input impedance of the RF input. In some applications, only 50 Ω are supported.

The command is not available for measurements with the optional "Digital Baseband" interface.

Parameters:

<Impedance> 50 | 75
 *RST: 50 Ω
 Default unit: OHM

Example: INP:IMP 75

Manual operation: See ["Impedance"](#) on page 69

INPut:SElect <Source>

Selects the signal source for measurements, i.e. it defines which connector is used to input data to the FSW.

If no additional input options are installed, only RF input or file input is supported.

For FSW85 models with two RF input connectors, you must select the input connector to configure first using [INPut:TYPE](#).

Parameters:

<Source> **RF**
 Radio Frequency ("RF INPUT" connector)

FIQ
 I/Q data file
 Not available for Input2.

DIQ
 Digital IQ data (only available with optional "Digital Baseband" interface)
 For details on I/Q input see the FSW I/Q Analyzer User Manual.
 Not available for Input2.

AIQ
 Analog Baseband signal (only available with optional "Analog Baseband" interface)
 Not available for Input2.

 *RST: RF

Example: INP:TYPE INP1
 For FSW85 models with two RF input connectors: selects the 1.00 mm RF input connector for configuration.
 INP:SEL RF

Manual operation: See ["Radio Frequency State"](#) on page 69

INPut:TYPE <Input>

The command selects the input path.

Parameters:

<Input>	INPUT1 Selects RF input 1. 1 mm [RF Input] connector
	INPUT2 Selects RF input 2. For FSW85 models with two RF input connectors: 1.85 mm [RF2 Input] connector For all other models: not available
	*RST: INPUT1

Example: //Select input path
INP:TYPE INPUT1

Manual operation: See "[Radio Frequency State](#)" on page 69

11.5.2.2 Configuring file input

The following commands are required to define input from a file.

Useful commands for configuring file input described elsewhere:

- [INPut:SElect](#) on page 169

Remote commands exclusive to configuring input from files:

INPut:FILE:PATH	170
MMEMory:LOAD:IQ:STReam	171
MMEMory:LOAD:IQ:STReam:AUTO	171
MMEMory:LOAD:IQ:STReam:LIST?	172
TRACe:IQ:FILE:REPetition:COUNT	172

INPut:FILE:PATH <FileName>[, <AnalysisBW>]

Selects the I/Q data file to be used as input for further measurements.

The I/Q data file must be in one of the following supported formats:

- .iq.tar
- .iqw
- .csv
- .mat
- .wv
- .aid

Only a single data stream or channel can be used as input, even if multiple streams or channels are stored in the file.

Configuring code domain analysis and time alignment error measurements

For some file formats that do not provide the sample rate and measurement time or record length, you must define these parameters manually. Otherwise the traces are not visible in the result displays.

Parameters:

<FileName> String containing the path and name of the source file.
The file type is determined by the file extension. If no file extension is provided, the file type is assumed to be `.iq.tar`.
For `.mat` files, Matlab® v4 is assumed.

<AnalysisBW> Optionally: The analysis bandwidth to be used by the measurement. The bandwidth must be smaller than or equal to the bandwidth of the data that was stored in the file.
Default unit: HZ

Example:

```
INP:FILE:PATH 'C:\R_S\Instr\user\data.iq.tar'
```

Uses I/Q data from the specified file as input.

Example:

```
//Load an IQW file
INP:SEL:FIQ
INP:FILE:PATH 'C:\R_S\Instr\user\data.iqw'
//Define the sample rate
TRAC:IQ:SRAT 10MHz
//Define the measurement time
SENSe:SWEep:TIME 0.001001
//Start the measurement
INIT:IMM
```

MMEMory:LOAD:IQ:STReam <Channel>

Only available for files that contain more than one data stream from multiple channels: selects the data stream to be used as input for the currently selected channel.

Automatic mode (`MMEMory:LOAD:IQ:STReam:AUTO`) is set to OFF.

Parameters:

<Channel> String containing the channel name.

Example:

```
MMEM:LOAD:IQ:STR?
//Result: 'Channel1','Channel2'
MMEM:LOAD:IQ:STR 'Channel2'
```

MMEMory:LOAD:IQ:STReam:AUTO <State>

Only available for files that contain more than one data stream from multiple channels: automatically defines which data stream in the file is used as input for the channel.

Parameters:

<State> ON | OFF | 0 | 1

OFF | 0

The data stream specified by `MMEMory:LOAD:IQ:STReam` is used as input for the channel.

Configuring code domain analysis and time alignment error measurements

ON | 1

The first data stream in the file is used as input for the channel. Applications that support multiple data streams use the first data stream in the file for the first input stream, the second for the second stream etc.

*RST: 1

MMEMory:LOAD:IQ:STReam:LIST?

Returns the available channels in the currently loaded input file.

Example: `MMEM:LOAD:IQ:STR?`
`//Result: 'Channel1','Channel2'`

Usage: Query only

TRACe:IQ:FILE:REPetition:COUNT <RepetitionCount>

Determines how often the data stream is repeatedly copied in the I/Q data memory. If the available memory is not sufficient for the specified number of repetitions, the largest possible number of complete data streams is used.

Parameters:

<RepetitionCount> integer

Example: `TRAC:IQ:FILE:REP:COUN 3`

11.5.2.3 Remote commands for the Digital Baseband interface (FSW-B17)

The following commands are required to control the "Digital Baseband" interface (FSW-B17) in a remote environment. They are only available if this option is installed.

Information on the `STATus:QUESTionable:DIQ` register can be found in "[STATus:QUESTionable:DIQ register](#)" on page 176.

- [Configuring digital I/Q input and output](#)..... 172
- [STATus:QUESTionable:DIQ register](#)..... 176

Configuring digital I/Q input and output**Remote commands exclusive to digital I/Q data input and output**

INPut:DIQ:CDEVIce	173
INPut:DIQ:RANGe:COUPling	173
INPut:DIQ:RANGe[:UPPer]	173
INPut:DIQ:RANGe[:UPPer]:AUTO	173
INPut:DIQ:RANGe[:UPPer]:UNIT	174
INPut:DIQ:SRATe	174
INPut:DIQ:SRATe:AUTO	174
OUTPut:DIQ[:STATe]	174
OUTPut<up>:DIQ:CDEVIce?	175

INPut:DIQ:CDEvice

Queries the current configuration and the status of the digital I/Q input from the optional "Digital Baseband" interface.

For details see the section "Interface Status Information" for the optional "Digital Baseband" interface in the FSW I/Q Analyzer User Manual.

Return values:

<Value>

Example:

```
INP:DIQ:CDEV?
```

Result:

```
1, SMW200A, 101190, BBMM 1 OUT,
100000000, 200000000, Passed, Passed, 1, 1. #QNAN
```

INPut:DIQ:RANGe:COUPling <State>

If enabled, the reference level for digital input is adjusted to the full scale level automatically if the full scale level changes.

Is only available if the optional "Digital Baseband" interface is installed.

Parameters:

<State> ON | OFF | 1 | 0

*RST: 0

INPut:DIQ:RANGe[:UPPer] <Level>

Defines or queries the "Full Scale Level", i.e. the level that corresponds to an I/Q sample with the magnitude "1".

Is only available if the optional "Digital Baseband" interface is installed.

Parameters:

<Level> Range: 1 μ V to 7.071 V

*RST: 1 V

Default unit: DBM

INPut:DIQ:RANGe[:UPPer]:AUTO <State>

If enabled, the digital input full scale level is automatically set to the value provided by the connected device (if available).

Is only available if the optional "Digital Baseband" interface is installed.

Parameters:

<State> ON | OFF | 1 | 0

*RST: 0

INPut:DIQ:RANGe[:UPPer]:UNIT <Level>

Defines the unit of the full scale level. The availability of units depends on the measurement application you are using.

Is only available if the optional "Digital Baseband" interface is installed.

Parameters:

<Level> DBM | DBPW | WATT | DBUV | DBMV | VOLT | DBUA | AMPere
*RST: Volt

INPut:DIQ:SRATe <SampleRate>

Specifies or queries the sample rate of the input signal from the optional "Digital Baseband" interface.

Parameters:

<SampleRate> Range: 1 Hz to 20 GHz
*RST: 32 MHz
Default unit: HZ

Example: INP:DIQ:SRAT 200 MHz

INPut:DIQ:SRATe:AUTO <State>

If enabled, the sample rate of the digital I/Q input signal is set automatically by the connected device.

Is only available if the optional "Digital Baseband" interface is installed.

Parameters:

<State> ON | OFF | 1 | 0
*RST: 0

OUTPut:DIQ[:STATe] <State>

Turns continuous output of I/Q data to the optional "Digital Baseband" interface on and off.

Using the digital input and digital output simultaneously is not possible.

If digital baseband output is active, the sample rate is restricted to 100 MHz (200 MHz if enhanced mode is possible; max. 160 MHz bandwidth).

Parameters:

<State> ON | OFF | 0 | 1
OFF | 0
Switches the function off
ON | 1
Switches the function on

Example: OUTP:DIQ ON

Manual operation: See "[Digital Baseband Output](#)" on page 73

OUTPut<up>:DIQ:CDEvice?

Queries the current configuration and the status of the digital I/Q data output to the optional "Digital Baseband" interface.

Suffix:

<up>

Return values:

<ConnState>	Defines whether a device is connected or not. 0 No device is connected. 1 A device is connected.
<DeviceName>	Device ID of the connected device
<SerialNumber>	Serial number of the connected device
<PortName>	Port name used by the connected device
<SampleRate>	Current data transfer rate of the connected device in Hz
<MaxTransferRate>	Maximum data transfer rate of the connected device in Hz
<ConnProtState>	State of the connection protocol which is used to identify the connected device. Not Started Has to be Started Started Passed Failed Done
<PRBSTestState>	State of the PRBS test. Not Started Has to be Started Started Passed Failed Done
<NotUsed>	to be ignored
<Placeholder>	for future use; currently "0"

Example:

```
OUTP:DIQ:CDEV?
Result:
1,SMW200A,101190,CODER 1 IN,
0,200000000,Passed,Done,0,0
```

Configuring code domain analysis and time alignment error measurements

- Usage:** Query only
- Manual operation:** See "Output Settings Information" on page 73
See "Connected Instrument" on page 73

STATus:QUESTionable:DIQ register

This register contains information about the state of the digital I/Q input and output. This register is used by the optional "Digital Baseband" interface.

The status of the `STATus:QUESTionable:DIQ` register is indicated in bit 14 of the `STATus:QUESTionable` register.

You can read out the state of the register with `STATus:QUESTionable:DIQ:CONDition?` on page 177 and `STATus:QUESTionable:DIQ[:EVENT]?` on page 178.

Bit No.	Meaning
0	Digital I/Q Input Device connected This bit is set if a device is recognized and connected to the "Digital Baseband" interface of the analyzer.
1	Digital I/Q Input Connection Protocol in progress This bit is set while the connection between analyzer and digital baseband data signal source (e.g. R&S SMW) is established.
2	Digital I/Q Input Connection Protocol error This bit is set if an error occurred during establishing of the connect between analyzer and digital I/Q data signal source (e.g. R&S SMW) is established.
3	Digital I/Q Input PLL unlocked This bit is set if the PLL of the Digital I/Q input is out of lock due to missing or unstable clock provided by the connected Digital I/Q TX device. To solve the problem the Digital I/Q connection has to be newly initialized after the clock has been restored.
4	Digital I/Q Input DATA Error This bit is set if the data from the Digital I/Q input module is erroneous. Possible reasons: <ul style="list-style-type: none"> • Bit errors in the data transmission. The bit will only be set if an error occurred at the current measurement. • Protocol or data header errors. May occur due to data synchronization problems or vast transmission errors. The bit will be set constantly and all data will be erroneous. To solve the problem the Digital I/Q connection has to be newly initialized. NOTE: If this error is indicated repeatedly either the Digital I/Q LVDS connection cable or the receiving or transmitting device might be defect.
5	Not used
6	Digital I/Q Input FIFO Overload This bit is set if the sample rate on the connected instrument is higher than the input sample rate setting on the FSW. Possible solution: <ul style="list-style-type: none"> • Reduce the sample rate on the connected instrument • Increase the input sample rate setting on the FSW
7	Not used
8	Digital I/Q Output Device connected This bit is set if a device is recognized and connected to the Digital I/Q Output.

Configuring code domain analysis and time alignment error measurements

Bit No.	Meaning
9	Digital I/Q Output Connection Protocol in progress This bit is set while the connection between analyzer and digital I/Q data signal source (e.g. R&S SMW) is established.
10	Digital I/Q Output Connection Protocol error This bit is set if an error occurred while the connection between analyzer and digital I/Q data signal source (e.g. R&S SMW) is established.
11	Digital I/Q Output FIFO Overload This bit is set if an overload of the Digital I/Q Output FIFO occurred. This happens if the output data rate is higher than the maximal data rate of the connected instrument. Reduce the sample rate to solve the problem.
12-14	Not used
15	This bit is always set to 0.

STATus:QUESTionable:DIQ:CONDition?	177
STATus:QUESTionable:DIQ:ENABLE	177
STATus:QUESTionable:DIQ:NTRansition	178
STATus:QUESTionable:DIQ:PTRansition	178
STATus:QUESTionable:DIQ[:EVENT]?	178

STATus:QUESTionable:DIQ:CONDition? <ChannelName>

Reads out the CONDition section of the STATus:QUESTionable:DIQ:CONDition status register.

The command does not delete the contents of the EVENT section.

Query parameters:

<ChannelName> String containing the name of the channel.
The parameter is optional. If you omit it, the command works for the currently active channel.

Example: STAT:QUES:DIQ:COND?

Usage: Query only

STATus:QUESTionable:DIQ:ENABLE <BitDefinition>, <ChannelName>

Controls the ENABLE part of a register.

The ENABLE part allows true conditions in the EVENT part of the status register to be reported in the summary bit. If a bit is 1 in the enable register and its associated event bit transitions to true, a positive transition will occur in the summary bit reported to the next higher level.

Parameters:

<ChannelName> String containing the name of the channel.
The parameter is optional. If you omit it, the command works for the currently active channel.

Setting parameters:

<SumBit> Range: 0 to 65535

STATus:QUESTionable:DIQ:NTRansition <BitDefinition>,<ChannelName>

Controls the Negative TRansition part of a register.

Setting a bit causes a 1 to 0 transition in the corresponding bit of the associated register. The transition also writes a 1 into the associated bit of the corresponding EVENT register.

Parameters:

<ChannelName> String containing the name of the channel.
The parameter is optional. If you omit it, the command works for the currently active channel.

Setting parameters:

<BitDefinition> Range: 0 to 65535

STATus:QUESTionable:DIQ:PTRansition <BitDefinition>,<ChannelName>

Controls the Positive TRansition part of a register.

Setting a bit causes a 0 to 1 transition in the corresponding bit of the associated register. The transition also writes a 1 into the associated bit of the corresponding EVENT register.

Parameters:

<ChannelName> String containing the name of the channel.
The parameter is optional. If you omit it, the command works for the currently active channel.

Setting parameters:

<BitDefinition> Range: 0 to 65535

STATus:QUESTionable:DIQ[:EVENT]? <ChannelName>

Queries the contents of the "EVENT" section of the STATus:QUESTionable:DIQ register for IQ measurements.

Readout deletes the contents of the "EVENT" section.

Query parameters:

<ChannelName> String containing the name of the channel.
The parameter is optional. If you omit it, the command works for the currently active channel.

Example: STAT:QUES:DIQ?

Usage: Query only

11.5.2.4 Configuring input via the optional Analog Baseband interface

The following commands are required to control the optional "Analog Baseband" interface in a remote environment. They are only available if this option is installed.

For more information on the "Analog Baseband" interface, see the FSW I/Q Analyzer User Manual.

Useful commands for Analog Baseband data described elsewhere:

- `INP:SEL AIQ` (see `INPut:SElect` on page 169)
- `[SENSe:]FREQuency:CENTer` on page 187

Commands for the Analog Baseband calibration signal are described in the FSW User Manual.

Remote commands exclusive to Analog Baseband data input and output

<code>INPut:IQ:BALanced[:STATe]</code>	179
<code>INPut:IQ:FULLscale:AUTO</code>	179
<code>INPut:IQ:FULLscale[:LEVel]</code>	180
<code>INPut:IQ:TYPE</code>	180
<code>CALibration:AIQ:HATiming[:STATe]</code>	180

`INPut:IQ:BALanced[:STATe]` <State>

Defines whether the input is provided as a differential signal via all 4 Analog Baseband connectors or as a plain I/Q signal via 2 single-ended lines.

Parameters:

<State> `ON | OFF | 1 | 0`
 ON | 1
 Differential
 OFF | 0
 Single ended
 *RST: 1

Example: `INP:IQ:BAL OFF`

`INPut:IQ:FULLscale:AUTO` <State>

Defines whether the full scale level (i.e. the maximum input power on the Baseband Input connector) is defined automatically according to the reference level, or manually.

Parameters:

<State> **ON | 1**
 Automatic definition
 OFF | 0
 Manual definition according to `INPut:IQ:FULLscale[:LEVel]` on page 180
 *RST: 1

Configuring code domain analysis and time alignment error measurements

Example: `INP:IQ:FULL:AUTO OFF`

INPut:IQ:FULLscale[:LEVel] <PeakVoltage>

Defines the peak voltage at the Baseband Input connector if the full scale level is set to manual mode (see `INPut:IQ:FULLscale:AUTO` on page 179).

Parameters:

<PeakVoltage> 0.25 V | 0.5 V | 1 V | 2 V
 Peak voltage level at the connector.
 For probes, the possible full scale values are adapted according to the probe's attenuation and maximum allowed power.
 *RST: 1V
 Default unit: V

Example: `INP:IQ:FULL 0.5V`

INPut:IQ:TYPE <DataType>

Defines the format of the input signal.

Parameters:

<DataType> IQ | I | Q
IQ
 The input signal is filtered and resampled to the sample rate of the application.
 Two input channels are required for each input signal, one for the in-phase component, and one for the quadrature component.
I
 The in-phase component of the input signal is filtered and resampled to the sample rate of the application. If the center frequency is not 0, the in-phase component of the input signal is down-converted first (Low IF I).
Q
 The quadrature component of the input signal is filtered and resampled to the sample rate of the application. If the center frequency is not 0, the quadrature component of the input signal is down-converted first (Low IF Q).
 *RST: IQ

Example: `INP:IQ:TYPE Q`

CALibration:AIQ:HATiming[:STATe] <State>

Activates a mode with enhanced timing accuracy between analog baseband, RF and external trigger signals.

Configuring code domain analysis and time alignment error measurements

For more information, see the FSW I/Q Analyzer and I/Q Input User Manual.

Parameters:

<State> ON | OFF | 0 | 1
 OFF | 0
 Switches the function off
 ON | 1
 Switches the function on

Example: CAL:AIQ:HAT:STAT ON

11.5.2.5 Setting up probes

Modular probes can be connected to the RF input connector of the FSW.

For details see the FSW User Manual.

Probes can also be connected to the optional "Baseband Input" connectors, if the "Analog Baseband" interface (option FSW-B71) is installed.

[SENSe:]PROBe<pb>:ID:PARTnumber?	181
[SENSe:]PROBe<pb>:ID:SRNumber?	182
[SENSe:]PROBe<pb>:SETup:ATTRatio	182
[SENSe:]PROBe<pb>:SETup:CMOOffset	182
[SENSe:]PROBe<pb>:SETup:DMOOffset	183
[SENSe:]PROBe<pb>:SETup:MODE	183
[SENSe:]PROBe<pb>:SETup:NAME?	184
[SENSe:]PROBe<pb>:SETup:NMOOffset	184
[SENSe:]PROBe<pb>:SETup:PMODE	184
[SENSe:]PROBe<pb>:SETup:PMOOffset	185
[SENSe:]PROBe<pb>:SETup:STATe?	185
[SENSe:]PROBe<pb>:SETup:TYPE?	186

[SENSe:]PROBe<pb>:ID:PARTnumber?

Queries the R&S part number of the probe.

Suffix:

<pb> 1..n
 Selects the connector:
 1 = Baseband Input I
 2 = Baseband Input Q
 3 = RF

Return values:

<PartNumber>

Example: //Query part number
 PROB3:ID:PART?

Usage: Query only

[SENSe:]PROBe<pb>:ID:SRNumber?

Queries the serial number of the probe.

Suffix:

<pb> 1..n
 Selects the connector:
 1 = Baseband Input I
 2 = Baseband Input Q
 3 = RF

Return values:

<SerialNo>

Example: //Query serial number
 PROB3:ID:SRN?

Usage: Query only

[SENSe:]PROBe<pb>:SETup:ATTRatio <AttenuationRatio>

Defines the attenuation applied to the input at the probe. This setting is only available for modular probes.

Suffix:

<pb> 1..n
 Selects the connector:
 1 = Baseband Input I
 2 = Baseband Input Q
 3 = RF

Parameters:

<AttenuationRatio> **10**
 Attenuation by 20 dB (ratio= 10:1)
2
 Attenuation by 6 dB (ratio= 2:1)
 *RST: 10
 Default unit: DB

[SENSe:]PROBe<pb>:SETup:CMOffset <CMOffset>

Sets the common mode offset. The setting is only available if a differential probe in CM-mode is connected to the FSW.

If the probe is disconnected, the common mode offset of the probe is reset to 0.0 V.

Note that if the offset for DM-mode or CM-mode is changed, the offsets for the P-mode and N-mode are adapted accordingly, and vice versa.

For details see the FSW User Manual.

Configuring code domain analysis and time alignment error measurements

Suffix:

<pb> 1..n
 Selects the connector:
 1 = Baseband Input I
 2 = Baseband Input Q
 3 = RF

Parameters:

<CMOffset> Offset of the mean voltage between the positive and negative input terminal vs. ground
 Range: -16 V to +16 V
 Default unit: V

[SENSe:]PROBe<pb>:SETup:DMOffset <DMOffset>

Sets the DM-mode offset. The setting is only available if a modular probe in DM-mode is connected to the FSW.

If the probe is disconnected, the DM-mode offset of the probe is reset to 0.0 V.

Note that if the offset for DM-mode or CM-mode is changed, the offsets for the P-mode and N-mode are adapted accordingly, and vice versa.

For details see the FSW User Manual.

Suffix:

<pb> 1..n
 Selects the connector:
 1 = Baseband Input I
 2 = Baseband Input Q
 3 = RF

Parameters:

<DMOffset> Voltage offset between the positive and negative input terminal
 Default unit: V

[SENSe:]PROBe<pb>:SETup:MODE <Mode>**Suffix:**

<pb> 1..n
 Selects the connector:
 1 = Baseband Input I
 2 = Baseband Input Q
 3 = RF

Parameters:

<Mode> RSINgle | NOActIon
RSINgle
 Run single: starts one data acquisition.
NOActIon
 Nothing is started on pressing the micro button.

[SENSe:]PROBe<pb>:SETup:NAME?

Queries the name of the probe.

Suffix:

<pb> 1..n
 Selects the connector:
 1 = Baseband Input I
 2 = Baseband Input Q
 3 = RF

Return values:

<Name> String containing the name of the probe.

Example:

```
//Query name of the probe
PROB3:SET:NAME?
```

Usage:

Query only

[SENSe:]PROBe<pb>:SETup:NMOffset <NMOffset>

Sets the N-mode offset. The setting is only available if a modular probe in N-mode is connected to the FSW. The maximum voltage difference between the positive and negative input terminals is 16 V.

If the probe is disconnected, the N-mode offset of the probe is reset to 0.0 V.

Note that if the offset for DM-mode or CM-mode is changed, the offsets for the P-mode and N-mode are adapted accordingly, and vice versa.

For details see the FSW User Manual.

Suffix:

<pb> 1..n
 Selects the connector:
 1 = Baseband Input I
 2 = Baseband Input Q
 3 = RF

Parameters:

<NMOffset> The voltage offset between the negative input terminal and ground.
 Default unit: V

[SENSe:]PROBe<pb>:SETup:PMODE <Mode>

Determines the mode of a multi-mode modular probe.

For details see the FSW User Manual.

Configuring code domain analysis and time alignment error measurements

Suffix:

<pb> 1..n
 Selects the connector:
 1 = Baseband Input I
 2 = Baseband Input Q
 3 = RF

Parameters:

<Mode> CM | DM | PM | NM
DM
 Voltage between the positive and negative input terminal
CM
 Mean voltage between the positive and negative input terminal vs. ground
PM
 Voltage between the positive input terminal and ground
NM
 Voltage between the negative input terminal and ground

Example:

SENS:PROB:SETU:PMOD PM
 Sets the probe to P-mode.

[SENSe:]PROBe<pb>:SETup:PMOffset <PMOffset>

Sets the P-mode offset. The setting is only available if a modular probe in P-mode is connected to the FSW. The maximum voltage difference between the positive and negative input terminals is 16 V.

If the probe is disconnected, the P-mode offset of the probe is reset to 0.0 V.

Note that if the offset for DM-mode or CM-mode is changed, the offsets for the P-mode and N-mode are adapted accordingly, and vice versa.

For details see the FSW User Manual.

Suffix:

<pb> 1..n
 Selects the connector:
 1 = Baseband Input I
 2 = Baseband Input Q
 3 = RF

Parameters:

<PMOffset> The voltage offset between the positive input terminal and ground.
 Default unit: V

[SENSe:]PROBe<pb>:SETup:STATe?

Queries if the probe at the specified connector is active (detected) or not active (not detected).

Configuring code domain analysis and time alignment error measurements

To switch the probe on, i.e. activate input from the connector, use `INP:SEL:AIQ` (see [INPut:SElect](#) on page 169).

Suffix:	
<pb>	1..n Selects the connector: 1 = Baseband Input I 2 = Baseband Input Q 3 = RF
Return values:	
<State>	DETEcted NDETEcted
Example:	//Query connector state PROB3:SET:STAT?
Usage:	Query only

[SENSe:]PROBe<pb>:SETup:TYPE?

Queries the type of the probe.

Suffix:	
<pb>	1..n Selects the connector: 1 = Baseband Input I 2 = Baseband Input Q 3 = RF
Return values:	
<Type>	String containing one of the following values: –"None" (no probe detected) –"active differential" –"active single-ended" –"active modular"
Example:	//Query probe type PROB3:SET:TYPE?
Usage:	Query only

11.5.2.6 Configuring the outputs

The following commands are required to provide output from the FSW.



Configuring trigger input/output is described in [Chapter 11.5.4.2, "Configuring the trigger output"](#), on page 201.

DIAGnostic:SERVice:NSOource	187
SYSTem:SPEaker:VOLume	187

DIAGnostic:SERVice:NSO <State>

Turns the 28 V supply of the BNC connector labeled [noise source control] on the FSW on and off.

Parameters:

<State> ON | OFF | 0 | 1
OFF | 0
 Switches the function off
ON | 1
 Switches the function on

Example: DIAG:SERV:NSO ON

Manual operation: See "Noise Source Control" on page 72

SYSTem:SPEaker:VOL <Volume>

Defines the volume of the built-in loudspeaker for demodulated signals. This setting is maintained for all applications.

The command is available in the time domain in Spectrum mode and in Analog Modulation Analysis mode.

Parameters:

<Volume> Percentage of the maximum possible volume.
 Range: 0 to 1
 *RST: 0.5

Example: SYST:SPE:VOL 0
 Switches the loudspeaker to mute.

11.5.3 Frontend configuration

The following commands configure frequency, amplitude and y-axis scaling settings, which represent the "frontend" of the measurement setup.

- [Frequency](#)..... 187
- [Amplitude settings](#)..... 189
- [Configuring the attenuation](#)..... 193

11.5.3.1 Frequency

[SENSe:]FREQUENCY:CENTer	187
[SENSe:]FREQUENCY:CENTer:STEP	188
[SENSe:]FREQUENCY:CENTer:STEP:AUTO	188
[SENSe:]FREQUENCY:OFFSet	188

[SENSe:]FREQUENCY:CENTer <Frequency>

Defines the center frequency.

Configuring code domain analysis and time alignment error measurements

Parameters:

<Frequency> For the allowed range and f_{max} , refer to the specifications document.

*RST: $f_{max}/2$

Default unit: Hz

Example:

```
FREQ:CENT 100 MHz
```

```
FREQ:CENT:STEP 10 MHz
```

```
FREQ:CENT UP
```

Sets the center frequency to 110 MHz.

Manual operation: See "[Center Frequency](#)" on page 80

[SENSe:]FREQuency:CENTer:STEP <StepSize>

Defines the center frequency step size.

You can increase or decrease the center frequency quickly in fixed steps using the `SENS:FREQ UP AND SENS:FREQ DOWN` commands, see [\[SENSe:\]FREQuency:CENTer](#) on page 187.

Parameters:

<StepSize> For f_{max} , refer to the specifications document.

Range: 1 to f_{MAX}

*RST: 0.1 x span

Default unit: Hz

Example:

```
//Set the center frequency to 110 MHz.
```

```
FREQ:CENT 100 MHz
```

```
FREQ:CENT:STEP 10 MHz
```

```
FREQ:CENT UP
```

Manual operation: See "[Center Frequency Stepsize](#)" on page 80

[SENSe:]FREQuency:CENTer:STEP:AUTO <State>

Couples or decouples the center frequency step size to the span.

In time domain (zero span) measurements, the center frequency is coupled to the RBW.

Parameters:

<State> ON | OFF | 0 | 1

*RST: 1

Example:

```
FREQ:CENT:STEP:AUTO ON
```

Activates the coupling of the step size to the span.

[SENSe:]FREQuency:OFFSet <Offset>

Defines a frequency offset.

Configuring code domain analysis and time alignment error measurements

If this value is not 0 Hz, the application assumes that the input signal was frequency shifted outside the application. All results of type "frequency" will be corrected for this shift numerically by the application.

See also "[Frequency Offset](#)" on page 81.

Note: In MSRA mode, the setting command is only available for the MSRA primary application. For MSRA secondary applications, only the query command is available.

Parameters:

<Offset> Range: -1 THz to 1 THz
 *RST: 0 Hz
 Default unit: HZ

Example: `FREQ:OFFS 1GHZ`

Manual operation: See "[Frequency Offset](#)" on page 81

11.5.3.2 Amplitude settings

The following commands are required to configure the amplitude settings in a remote environment.

Useful commands for amplitude settings described elsewhere:

- [INPut:COUPling](#) on page 167
- [INPut:IMPedance](#) on page 169
- [\[SENSe:\]ADJust:LEVel](#) on page 222

Remote commands exclusive to amplitude settings:

<code>DISPlay[:WINDow<n>][:SUBWindow<w>]:TRACe<t>:Y[:SCALe]</code>	189
<code>DISPlay[:WINDow<n>][:SUBWindow<w>]:TRACe<t>:Y[:SCALe]:AUTO ONCE</code>	190
<code>DISPlay[:WINDow<n>][:SUBWindow<w>]:TRACe<t>:Y[:SCALe]:PDIVision</code>	190
<code>DISPlay[:WINDow<n>][:SUBWindow<w>]:TRACe<t>:Y[:SCALe]:RLEVel</code>	190
<code>DISPlay[:WINDow<n>][:SUBWindow<w>]:TRACe<t>:Y[:SCALe]:RLEVel:OFFSet</code>	191
<code>DISPlay[:WINDow<n>]:TRACe<t>:Y[:SCALe]:MAXimum</code>	191
<code>DISPlay[:WINDow<n>]:TRACe<t>:Y[:SCALe]:MINimum</code>	191
<code>INPut:EGAIN[:STATe]</code>	192
<code>INPut:GAIN:STATe</code>	192
<code>INPut:GAIN[:VALue]</code>	193

DISPlay[:WINDow<n>][:SUBWindow<w>]:TRACe<t>:Y[:SCALe] <Range>

Defines the display range of the y-axis (for all traces).

Suffix:

<n> [Window](#)
 <w> subwindow
 Not supported by all applications
 <t> irrelevant

Example: `DISP:TRAC:Y 110dB`

DISPlay[:WINDow<n>][:SUBWindow<w>]:TRACe<t>:Y[:SCALe]:AUTO ONCE

Automatic scaling of the y-axis is performed once, then switched off again (for all traces).

Suffix:

<n> [Window](#)

<t> irrelevant

Manual operation: See "[Auto Scale Once](#)" on page 79

**DISPlay[:WINDow<n>][:SUBWindow<w>]:TRACe<t>:Y[:SCALe]:PDIVision
<Value>**

This remote command determines the grid spacing on the Y-axis for all diagrams, where possible.

In spectrum displays, for example, this command is not available.

Suffix:

<n> [Window](#)

<w> subwindow
Not supported by all applications

<t> irrelevant

Parameters:

<Value> numeric value WITHOUT UNIT (unit according to the result display)

Defines the range per division (total range = 10*[Value](#))

*RST: depends on the result display

Default unit: DBM

Example:

```
DISP:TRAC:Y:PDIV 10
```

Sets the grid spacing to 10 units (e.g. dB) per division

(For example 10 dB in the "Code Domain Power" result display.)

**DISPlay[:WINDow<n>][:SUBWindow<w>]:TRACe<t>:Y[:SCALe]:RLEVEL
<ReferenceLevel>**

Defines the reference level (for all traces in all windows).

With a reference level offset $\neq 0$, the value range of the reference level is modified by the offset.

Suffix:

<n> irrelevant

<w> subwindow
Not supported by all applications

<t> irrelevant

Configuring code domain analysis and time alignment error measurements

Parameters:

<ReferenceLevel> The unit is variable.
 Range: see specifications document
 *RST: 0 dBm
 Default unit: DBM

Example: DISP:TRAC:Y:RLEV -60dBm

Manual operation: See "[Reference Level](#)" on page 75

DISPlay[:WINDow<n>][:SUBWindow<w>]:TRACe<t>:Y[:SCALe]:RLEVel:OFFSet
 <Offset>

Defines a reference level offset (for all traces in all windows).

Suffix:

<n> irrelevant
 <w> subwindow
 Not supported by all applications
 <t> irrelevant

Parameters:

<Offset> Range: -200 dB to 200 dB
 *RST: 0dB
 Default unit: DB

Example: DISP:TRAC:Y:RLEV:OFFS -10dB

Manual operation: See "[Shifting the Display \(Offset\)](#)" on page 76

DISPlay[:WINDow<n>]:TRACe<t>:Y[:SCALe]:MAXimum <Value>

Defines the maximum value on the y-axis in the specified window.

Suffix:

<n> [Window](#)
 <t> irrelevant

Parameters:

<Max> numeric value

Example: DISP:WIND2:TRAC:Y:SCAL:MAX 10

Manual operation: See "[Y-Maximum, Y-Minimum](#)" on page 79

DISPlay[:WINDow<n>]:TRACe<t>:Y[:SCALe]:MINimum <Value>

Defines the minimum value on the y-axis in the specified window.

Suffix:

<n> [Window](#)
 <t> irrelevant

Parameters:**<Min>** numeric value**Example:**

DISP:WIND2:TRAC:Y:SCAL:MIN -90

Manual operation:See "[Y-Maximum, Y-Minimum](#)" on page 79**INPut:EGain[:STATe] <State>**

Before this command can be used, the external preamplifier must be connected to the FSW. See the preamplifier's documentation for details.

When activated, the FSW automatically compensates the magnitude and phase characteristics of the external preamplifier in the measurement results.

Note that when an optional external preamplifier is activated, the internal preamplifier is automatically disabled, and vice versa.

For FSW85 models with two RF inputs, you must enable correction from the external preamplifier for each input individually. Correction cannot be enabled for both inputs at the same time.

When deactivated, no compensation is performed even if an external preamplifier remains connected.

Parameters:**<State>** ON | OFF | 0 | 1**OFF | 0**

No data correction is performed based on the external preamplifier

ON | 1

Performs data corrections based on the external preamplifier

*RST: 0

Example:

INP:EGA ON

Manual operation:See "[Ext. PA Correction](#)" on page 78**INPut:GAIN:STATe <State>**

Turns the internal preamplifier on and off. It requires the optional preamplifier hardware.

Note that if an optional external preamplifier is activated, the internal preamplifier is automatically disabled, and vice versa.

Is not available for input from the optional "Digital Baseband" interface.

For all FSW models except for FSW85, the preamplification is defined by [INPut:GAIN\[:VALue\]](#).

For older FSW43/FSW50/FSW67 models, the input signal is always amplified by about 30 dB when the preamplifier is active.

For FSW85 models, no preamplifier is available.

Configuring code domain analysis and time alignment error measurements

If option R&S FSW-B22 is installed, the preamplifier is only active below 7 GHz.

If option R&S FSW-B24 is installed, the preamplifier is active for all frequencies.

Parameters:

<State> ON | OFF | 0 | 1
OFF | 0
 Switches the function off
ON | 1
 Switches the function on
 *RST: 0

Example:

```
INP:GAIN:STAT ON
INP:GAIN:VAL 15
```

Switches on 15 dB preamplification.

Manual operation: See "[Preamplifier](#)" on page 78

INPut:GAIN[:VALue] <Gain>

Selects the "gain" if the preamplifier is activated (INP:GAIN:STAT ON, see [INPut:GAIN:STATe](#) on page 192).

The command requires the additional preamplifier hardware option.

Parameters:

<Gain> For all FSW models except for FSW85, the following settings are available:
 15 dB and 30 dB
 All other values are rounded to the nearest of these two.
 30 dB
 For older FSW43/FSW50/FSW67 models, the input signal is always amplified by about 30 dB when the preamplifier is active.
 For FSW85 models, no preamplifier is available.
 Default unit: DB

Example:

```
INP:GAIN:STAT ON
INP:GAIN:VAL 30
```

Switches on 30 dB preamplification.

Manual operation: See "[Preamplifier](#)" on page 78

11.5.3.3 Configuring the attenuation

INPut:ATTenuation	194
INPut:ATTenuation:AUTO	194
INPut:EATT	194
INPut:EATT:AUTO	195
INPut:EATT:STATe	195

INPut:ATTenuation <Attenuation>

Defines the total attenuation for RF input.

If an electronic attenuator is available and active, the command defines a mechanical attenuation (see [INPut:EATT:STATE](#) on page 195).

If you set the attenuation manually, it is no longer coupled to the reference level, but the reference level is coupled to the attenuation. Thus, if the current reference level is not compatible with an attenuation that has been set manually, the command also adjusts the reference level.

Is not available if the optional "Digital Baseband" interface is active.

Parameters:

<Attenuation> Range: see specifications document
 Increment: 5 dB (with optional electr. attenuator: 1 dB)
 *RST: 10 dB (AUTO is set to ON)
 Default unit: DB

Example:

INP:ATT 30dB

Defines a 30 dB attenuation and decouples the attenuation from the reference level.

Manual operation: See "[Attenuation Mode / Value](#)" on page 76

INPut:ATTenuation:AUTO <State>

Couples or decouples the attenuation to the reference level. Thus, when the reference level is changed, the FSW determines the signal level for optimal internal data processing and sets the required attenuation accordingly.

Is not available if the optional "Digital Baseband" interface is active.

Parameters:

<State> ON | OFF | 0 | 1
 *RST: 1

Example:

INP:ATT:AUTO ON

Couples the attenuation to the reference level.

Manual operation: See "[Attenuation Mode / Value](#)" on page 76

INPut:EATT <Attenuation>

Defines an electronic attenuation manually. Automatic mode must be switched off (INP:EATT:AUTO OFF, see [INPut:EATT:AUTO](#) on page 195).

If the current reference level is not compatible with an attenuation that has been set manually, the command also adjusts the reference level.

Requires the electronic attenuation hardware option.

It is not available if the optional "Digital Baseband" interface is active.

Configuring code domain analysis and time alignment error measurements

Parameters:

<Attenuation> attenuation in dB
 Range: see specifications document
 Increment: 1 dB
 *RST: 0 dB (OFF)
 Default unit: DB

Example:

```
INP:EATT:AUTO OFF
INP:EATT 10 dB
```

Manual operation: See ["Using Electronic Attenuation"](#) on page 77

INPut:EATT:AUTO <State>

Turns automatic selection of the electronic attenuation on and off.

If on, electronic attenuation reduces the mechanical attenuation whenever possible.

Requires the electronic attenuation hardware option.

It is not available if the optional "Digital Baseband" interface is active.

Parameters:

<State> ON | OFF | 0 | 1
 OFF | 0
 Switches the function off
 ON | 1
 Switches the function on
 *RST: 1

Example:

```
INP:EATT:AUTO OFF
```

Manual operation: See ["Using Electronic Attenuation"](#) on page 77

INPut:EATT:STATe <State>

Turns the electronic attenuator on and off.

Requires the electronic attenuation hardware option.

It is not available if the optional "Digital Baseband" interface is active.

Parameters:

<State> ON | OFF | 0 | 1
 OFF | 0
 Switches the function off
 ON | 1
 Switches the function on
 *RST: 0

Example:

```
INP:EATT:STAT ON
```

Switches the electronic attenuator into the signal path.

Manual operation: See ["Using Electronic Attenuation"](#) on page 77

11.5.4 Configuring triggered measurements

The following commands are required to configure a triggered measurement in a remote environment.

The tasks for manual operation are described in [Chapter 5.2.5, "Trigger settings"](#), on page 81



The *OPC command should be used after commands that retrieve data so that subsequent commands to change the selected trigger source are held off until after the sweep is completed and the data has been returned.

- [Configuring the triggering conditions](#).....196
- [Configuring the trigger output](#).....201

11.5.4.1 Configuring the triggering conditions

The following commands are required to configure a triggered measurement.

TRIGger[:SEQuence]:DTIME.....	196
TRIGger[:SEQuence]:HOLDoff[:TIME].....	196
TRIGger[:SEQuence]:IFPower:HOLDoff.....	197
TRIGger[:SEQuence]:IFPower:HYSteresis.....	197
TRIGger[:SEQuence]:LEVel:BBPower.....	197
TRIGger[:SEQuence]:LEVel[:EXternal<port>].....	198
TRIGger[:SEQuence]:LEVel:IFPower.....	198
TRIGger[:SEQuence]:LEVel:RFPower.....	199
TRIGger[:SEQuence]:LEVel:VIDeo.....	199
TRIGger[:SEQuence]:SLOPe.....	199
TRIGger[:SEQuence]:SOURce.....	199
TRIGger[:SEQuence]:TIME:RINTerval.....	201

TRIGger[:SEQuence]:DTIME <DropoutTime>

Defines the time the input signal must stay below the trigger level before a trigger is detected again.

For input from the "Analog Baseband" interface using the baseband power trigger (BBP), the default drop out time is set to 100 ns to avoid unintentional trigger events (as no hysteresis can be configured in this case).

Parameters:

<DropoutTime>	Dropout time of the trigger.
Range:	0 s to 10.0 s
*RST:	0 s
Default unit:	S

TRIGger[:SEQuence]:HOLDoff[:TIME] <Offset>

Defines the time offset between the trigger event and the start of the measurement.

Parameters:

<Offset> *RST: 0 s
 Default unit: S

Example: TRIG:HOLD 500us

Manual operation: See ["Trigger Offset"](#) on page 84

TRIGger[:SEquence]:IFPower:HOLDoff <Period>

Defines the holding time before the next trigger event.

Note that this command can be used for **any trigger source**, not just IF Power (despite the legacy keyword).

Note: If you perform gated measurements in combination with the IF Power trigger, the FSW ignores the holding time for frequency sweep, FFT sweep, zero span and I/Q data measurements.

Parameters:

<Period> Range: 0 s to 10 s
 *RST: 0 s
 Default unit: S

Example: TRIG:SOUR EXT
 Sets an external trigger source.
 TRIG:IFP:HOLD 200 ns
 Sets the holding time to 200 ns.

TRIGger[:SEquence]:IFPower:HYSTeresis <Hysteresis>

Defines the trigger hysteresis, which is only available for "IF Power" trigger sources.

Parameters:

<Hysteresis> Range: 3 dB to 50 dB
 *RST: 3 dB
 Default unit: DB

Example: TRIG:SOUR IFP
 Sets the IF power trigger source.
 TRIG:IFP:HYST 10DB
 Sets the hysteresis limit value.

TRIGger[:SEquence]:LEVel:BBPower <Level>

Sets the level of the baseband power trigger.

Is available for the optional "Digital Baseband" interface.

Is available for the optional "Analog Baseband" interface.

Configuring code domain analysis and time alignment error measurements

Parameters:

<Level> Range: -50 dBm to +20 dBm
 *RST: -20 dBm
 Default unit: DBM

Example: TRIG:LEV:BBP -30DBM

Manual operation: See "[Trigger Level](#)" on page 84

TRIGger[:SEquence]:LEVel[:EXTernal<port>] <TriggerLevel>

Defines the level the external signal must exceed to cause a trigger event.

Note that the variable "Input/Output" connectors (ports 2+3) must be set for use as input using the `OUTPut:TRIGger<tp>:DIRection` command.

Suffix:

<port> Selects the trigger port.
 1 = trigger port 1 (TRIGGER INPUT connector on front panel)
 2 = trigger port 2 (TRIGGER INPUT/OUTPUT connector on front panel)
 (Not available for FSW85 models with two RF input connectors.)
 3 = trigger port 3 (TRIGGER3 INPUT/OUTPUT connector on rear panel)

Parameters:

<TriggerLevel> Range: 0.5 V to 3.5 V
 *RST: 1.4 V
 Default unit: V

Example: TRIG:LEV 2V

Manual operation: See "[Trigger Level](#)" on page 84

TRIGger[:SEquence]:LEVel:IFPower <TriggerLevel>

Defines the power level at the third intermediate frequency that must be exceeded to cause a trigger event.

Note that any RF attenuation or preamplification is considered when the trigger level is analyzed. If defined, a reference level offset is also considered.

For compatibility reasons, this command is also available for the "Baseband Power" trigger source when using the "Analog Baseband" interface.

Parameters:

<TriggerLevel> For details on available trigger levels and trigger bandwidths, see the specifications document.
 *RST: -20 dBm
 Default unit: DBM

Example: TRIG:LEV:IFP -30DBM

TRIGger[:SEquence]:LEVel:RFPower <TriggerLevel>

Defines the power level the RF input must exceed to cause a trigger event. Note that any RF attenuation or preamplification is considered when the trigger level is analyzed. If defined, a reference level offset is also considered.

The input signal must be between 500 MHz and 8 GHz.

Parameters:

<TriggerLevel> For details on available trigger levels and trigger bandwidths, see the specifications document.

*RST: -20 dBm

Default unit: DBM

Example:

TRIG:LEV:RFP -30dBm

TRIGger[:SEquence]:LEVel:VIDeo <Level>

Defines the level the video signal must exceed to cause a trigger event. Note that any RF attenuation or preamplification is considered when the trigger level is analyzed.

Parameters:

<Level> Range: 0 PCT to 100 PCT

*RST: 50 PCT

Default unit: PCT

Example:

TRIG:LEV:VID 50PCT

TRIGger[:SEquence]:SLOPe <Type>

For external and time domain trigger sources, you can define whether triggering occurs when the signal rises to the trigger level or falls down to it.

Parameters:

<Type> POSitive | NEGative

POSitive

Triggers when the signal rises to the trigger level (rising edge).

NEGative

Triggers when the signal drops to the trigger level (falling edge).

*RST: POSitive

Example:

TRIG:SLOP NEG

Manual operation: See "[Slope](#)" on page 84

TRIGger[:SEquence]:SOURce <Source>

Selects the trigger source.

Note on external triggers:

Configuring code domain analysis and time alignment error measurements

If a measurement is configured to wait for an external trigger signal in a remote control program, remote control is blocked until the trigger is received and the program can continue. Make sure that this situation is avoided in your remote control programs.

Parameters:

<Source>

IMMediate

Free Run

EXTernal

Trigger signal from the "Trigger Input" connector.

EXT2

Trigger signal from the "Trigger Input/Output" connector.

For FSW85 models, Trigger 2 is not available due to the second RF input connector on the front panel. The trigger signal is taken from the "Trigger Input/Output" connector on the rear panel.

Note: Connector must be configured for "Input".

EXT3

Trigger signal from the "TRIGGER 3 INPUT/ OUTPUT" connector.

Note: Connector must be configured for "Input".

TIME

Time interval

(For frequency and time domain measurements only.)

BBPower

Baseband power

For input from the optional "Analog Baseband" interface.

For input from the optional "Digital Baseband" interface.

GP0 | GP1 | GP2 | GP3 | GP4 | GP5

For applications that process I/Q data, such as the I/Q Analyzer or optional applications, and only if the optional "Digital Baseband" interface is available.

Defines triggering of the measurement directly via the LVDS connector. The parameter specifies which general-purpose bit (0 to 5) provides the trigger data.

The assignment of the general-purpose bits used by the Digital IQ trigger to the LVDS connector pins is provided in "[Digital I/Q](#)" on page 83.

*RST: IMMediate

Example:

```
TRIG:SOUR EXT
```

Selects the external trigger input as source of the trigger signal

Manual operation:

See "[Trigger Source](#)" on page 82

See "[Free Run](#)" on page 82

See "[External Trigger 1/2/3](#)" on page 82

See "[Digital I/Q](#)" on page 83

See "[IF Power](#)" on page 83

TRIGger[:SEQuence]:TIME:RINTerval <Interval>

Defines the repetition interval for the time trigger.

Parameters:

<Interval> numeric value
 Range: 2 ms to 5000 s
 *RST: 1.0 s
 Default unit: S

Example:

```
TRIG:SOUR TIME
Selects the time trigger input for triggering.
TRIG:TIME:RINT 5
The measurement starts every 5 s.
```

11.5.4.2 Configuring the trigger output

The following commands are required to send the trigger signal to one of the variable "TRIGGER INPUT/OUTPUT" connectors on the FSW.

OUTPut:TRIGger<tp>:DIRection.....	201
OUTPut:TRIGger<tp>:LEVel.....	201
OUTPut:TRIGger<tp>:OTYPe.....	202
OUTPut:TRIGger<tp>:PULSe:IMMEDIATE.....	202
OUTPut:TRIGger<tp>:PULSe:LENGth.....	203

OUTPut:TRIGger<tp>:DIRection <Direction>

Selects the trigger direction for trigger ports that serve as an input as well as an output.

Suffix:

<tp> Selects the used trigger port.
 2 = trigger port 2 (front)
 (Not available for FSW85 models with two RF input connectors.)
 3 = trigger port 3 (rear panel)

Parameters:

<Direction> INPut | OUTPut
INPut
 Port works as an input.
OUTPut
 Port works as an output.
 *RST: INPut

Manual operation: See "[Trigger 2/3](#)" on page 85

OUTPut:TRIGger<tp>:LEVel <Level>

Defines the level of the (TTL compatible) signal generated at the trigger output.

Configuring code domain analysis and time alignment error measurements

Works only if you have selected a user-defined output with `OUTPut:TRIGger<tp>:OTYPe`.

Suffix:

<tp> 1..n
 Selects the trigger port to which the output is sent.
 2 = trigger port 2 (front)
 (Not available for FSW85 models with two RF input connectors.)
 3 = trigger port 3 (rear)

Parameters:

<Level> **HIGH**
 5 V
LOW
 0 V
 *RST: LOW

Example: `OUTP:TRIG2:LEV HIGH`

Manual operation: See "[Level](#)" on page 86

OUTPut:TRIGger<tp>:OTYPe <OutputType>

Selects the type of signal generated at the trigger output.

Suffix:

<tp> 1..n
 Selects the trigger port to which the output is sent.
 2 = trigger port 2 (front)
 (Not available for FSW85 models with two RF input connectors.)
 3 = trigger port 3 (rear)

Parameters:

<OutputType> **DEVIce**
 Sends a trigger signal when the FSW has triggered internally.
TARMed
 Sends a trigger signal when the trigger is armed and ready for an external trigger event.
UDEFI ned
 Sends a user-defined trigger signal. For more information, see [OUTPut:TRIGger<tp>:LEVel](#).
 *RST: DEVIce

Manual operation: See "[Output Type](#)" on page 85

OUTPut:TRIGger<tp>:PULSe:IMMediate

Generates a pulse at the trigger output.

Configuring code domain analysis and time alignment error measurements

Suffix:

<tp> 1..n
 Selects the trigger port to which the output is sent.
 2 = trigger port 2 (front)
 (Not available for FSW85 models with two RF input connectors.)
 3 = trigger port 3 (rear)

Manual operation: See ["Send Trigger"](#) on page 86

OUTPut:TRIGger<tp>:PULSe:LENGth <Length>

Defines the length of the pulse generated at the trigger output.

Suffix:

<tp> Selects the trigger port to which the output is sent.
 2 = trigger port 2 (front)
 (Not available for FSW85 models with two RF input connectors.)
 3 = trigger port 3 (rear)

Parameters:

<Length> Pulse length in seconds.
 Default unit: S

Example: `OUTP:TRIG2:PULS:LENG 0.02`

Manual operation: See ["Pulse Length"](#) on page 86

11.5.5 Signal capturing

The following commands are required to configure how much and how data is captured from the input signal.

**MSRA operating mode**

In MSRA operating mode, only the MSRA primary channel actually captures data from the input signal. The data acquisition settings for the 3GPP FDD application in MSRA mode define the **application data** (see [Chapter 11.12, "Configuring the secondary application data range \(MSRA mode only\)"](#), on page 286).

For details on the MSRA operating mode see the FSW MSRA User Manual.

Useful commands for configuring data acquisition described elsewhere:

- [\[SENSe:\]CDPower:FRAMe\[:VALue\]](#) on page 223

Remote commands exclusive to signal capturing:

[SENSe:]CDPower:BASE	204
[SENSe:]CDPower:FILTer[:STATe]	204
[SENSe:]CDPower:IQLength	204
[SENSe:]CDPower:SBANd	204
[SENSe:]SWAPiq	205

[SENSe:]CDPower:BASE <BaseValue>

Defines the base of the CDP analysis.

Parameters:

<BaseValue> SLOT | FRAME

SLOT

Only one slot of the signal is analyzed.

FRAME

The complete 3GPP frame is analyzed.

*RST: FRAME

Example: CDP:BASE SLOT

Manual operation: See "[Capture Mode](#)" on page 88

[SENSe:]CDPower:FILTer[:STATe] <State>

This command selects if a root raised cosine (RRC) receiver filter is used or not. This feature is useful if the RRC filter is implemented in the device under test (DUT).

Parameters:

<State> ON | 1

If an unfiltered signal is received (normal case), the RRC filter should be used to get a correct signal demodulation.

OFF | 0

If a filtered signal is received, the RRC filter should not be used to get a correct signal demodulation. This is the case if the DUT filters the signal.

*RST: 1

Example: SENS:CDP:FILT:STAT OFF

Manual operation: See "[RRC Filter State](#)" on page 88

[SENSe:]CDPower:IQLength <CaptureLength>

Specifies the number of frames that are captured by one sweep.

Parameters:

<CaptureLength> Range: 1 to 100

*RST: 1

Example: SENS:CDP:IQLength 3

Manual operation: See "[Capture Length \(Frames\)](#)" on page 88

[SENSe:]CDPower:SBANd <NORMallNVers>

Is used to swap the left and right sideband.

Parameters:

<NORMalINVers> NORMal | INVerse
 *RST: NORM

Example:

CDP:SBAN INV
 Switches the right and left sideband.

[SENSe:]SWAPiq <State>

Defines whether or not the recorded I/Q pairs should be swapped (I<->Q) before being processed. Swapping I and Q inverts the sideband.

This is useful if the DUT interchanged the I and Q parts of the signal; then the FSW can do the same to compensate for it.

Parameters:

<State> **ON | 1**
 I and Q signals are interchanged
 Inverted sideband, $Q+j*I$
 OFF | 0
 I and Q signals are not interchanged
 Normal sideband, $I+j*Q$
 *RST: 0

Manual operation: See "[Swap I/Q](#)" on page 87

11.5.6 Synchronization

For BTS tests, the individual channels in the input signal need to be synchronized to detect timing offsets in the slot spacings. These commands are described here. they are only available in the 3GPP FDD BTS application

Useful commands for synchronization described elsewhere:

- [\[SENSe:\]CDPower:ANTenna](#) on page 161

Remote commands exclusive to synchronization:

[\[SENSe:\]CDPower:UCPich:ANTenna<antenna>:CODE](#)..... 205
[\[SENSe:\]CDPower:STYPe](#)..... 206

[SENSe:]CDPower:UCPich:ANTenna<antenna>:CODE <CodeNumber>

Sets the code number of the user defined CPICH used for signal analysis.

Note: this command is equivalent to the command [\[SENSe:\]CDPower:UCPich:CODE](#) on page 293 for antenna 1.

Suffix:

<antenna> 1..n
 Antenna to be configured

Configuring code domain analysis and time alignment error measurements

Parameters:

<CodeNumber> Range: 0 to 225
*RST: 0

Example:

SENS:CDP:UCP:ANT2:CODE 10

Mode:

BTS application only

Manual operation:

See "[S-CPICH Code Nr](#)" on page 90

[SENSe:]CDPower:STYPe <Type>

Selects the type of synchronization.

Parameters:

<Type> CPICH | SCHannel

CPICH

Synchronization is carried out to CPICH. For this type of synchronization, the CPICH must be available in the input signal.

SCHannel

Synchronization is carried out without CPICH. This type of synchronization is required for test model 4 without CPICH.

*RST: CPICH

Example:

SENS:CDP:STYP SCH

Mode:

BTS application only

Manual operation:

See "[Synchronization Type](#)" on page 90

11.5.7 Channel detection

The channel detection settings determine which channels are found in the input signal. The commands for working with channel tables are described here.

When the channel type is required as a parameter by a remote command or provided as a result for a remote query, the following abbreviations and assignments to a numeric value are used:

Table 11-4: BTS channel types and their assignment to a numeric parameter value

Param.	Channel type	Description
0	DPCH	Dedicated Physical Channel of a standard frame
1	PICH	Paging Indication Channel
2	CPICH	Common Pilot Channel
3	PSCH	Primary Synchronization Channel
4	SSCH	Secondary Synchronization Channel
5	PCCPCH	Primary Common Control Physical Channel
6	SCCPCH	Secondary Common Control Physical Channel

Configuring code domain analysis and time alignment error measurements

Param.	Channel type	Description
7	HS_SCCH	HSDPA: H igh S peed S hared C ontrol C hannel
8	HS_PDSCH	HSDPA: H igh S peed P hysical D ownlink S hared C hannel
9	CHAN	Channel without any pilot symbols (QPSK modulated)
10	CPRSD	Dedicated Physical Channel in compressed mode
11	CPR-TPC	Dedicated Physical Channel in compressed mode TPC symbols are sent in the first slot of the gap.
12	CPR-SF/2	Dedicated Physical Channel in compressed mode using half spreading factor (SF/2).
13	CPR-SF/2-TPC	Dedicated Physical Channel in compressed mode using half spreading factor (SF/2). TPC symbols are sent in the first slot of the gap.
14	EHICH-ERGCH	HSUPA: E nhanced H ARQ Hybrid Acknowledgement Indicator C hannel HSUPA: E nhanced R elative G rant C hannel
15	EAGCH	E-AGCH: E nhanced A bsolute G rant C hannel
16	SCPICH	S econdary C ommon P ilot C hannel

Table 11-5: UE channel types and their assignment to a numeric parameter value

Param.	Channel type	Description
0	DPDCH	Dedicated Physical Data Channel
1	DPCCH	Dedicated Physical Control Channel
2	HS-DPCCH	High-Speed Dedicated Physical Control Channel
3	E-DPCCH	Enhanced Dedicated Physical Control Channel
4	E_DPDCH	Enhanced Dedicated Physical Data Channel

- [General channel detection](#).....207
- [Managing channel tables](#).....209
- [Configuring channel tables](#).....213
- [Configuring channel details \(BTS measurements\)](#).....215
- [Configuring channel details \(UE measurements\)](#).....216

11.5.7.1 General channel detection

The following commands configure how channels are detected in general.

Useful commands for general channel detection described elsewhere:

- [CONFigure:WCDPower\[:BTS\]:CTABLE\[:STATe\]](#) on page 209
- [CONFigure:WCDPower\[:BTS\]:CTABLE:SElect](#) on page 211
- [CONFigure:WCDPower:MS:CTABLE\[:STATe\]](#) on page 211
- [CONFigure:WCDPower:MS:CTABLE:SElect](#) on page 213

Remote commands exclusive to general channel detection:

CONFigure:WCDPower[:BTS]:CTABLE:COMPare	208
CONFigure:WCDPower:MS:CTABLE:TOFFset	208
[SENSe:]CDPower:ICTReshold	209

CONFigure:WCDPower[:BTS]:CTABLE:COMPare <State>

Switches between normal predefined mode and predefined channel table compare mode.

In the compare mode a predefined channel table model can be compared with the measurement in respect to power, pilot length and timing offset of the active channels.

Comparison is a submode of predefined channel table measurement. It only influences the measurement if the "Channel Search Mode" is set to *Predefined* (see [CONFigure:WCDPower\[:BTS\]:CTABLE\[:STaTe\]](#) on page 209). If the compare mode is selected, the power values, pilot lengths and timing offsets are measured and are compared with the values from the predefined channel table. The "Timing Offset" setting is disabled in this case. The differences between the measured and the predefined values are visualized in the corresponding columns of the "CHANNEL TABLE" evaluation (see "[Channel Table](#)" on page 20). The following columns are displayed in the channel table:

- **PilotL** is the subtraction of PilotLengthMeasured - PilotLengthPredefined
- **PwrRel** is the subtraction of PowerRelMeasured - PowerRelPredefined
- **T Offs** is the subtraction of TimingOffsetMeasured - TimingOffsetPredefined

For non-active channels dashes are shown.

Parameters:

<State> ON | OFF | 1 | 0
 ON | 1
 Predefined channel table compare mode
 OFF | 0
 Normal predefined mode
 *RST: 0

Example: CONF:WCDP:CTAB:COMP ON

Mode: BTS application only

Manual operation: See "[Comparing the Measurement Signal with the Predefined Channel Table](#)" on page 93

CONFigure:WCDPower:MS:CTABLE:TOFFset <arg0>**Parameters:**

<arg0> PREDefine | MEASurement

Manual operation: See "[Timing Offset Reference](#)" on page 93

[SENSe:]CDPower:ICTReshold <ThresholdLevel>

Defines the minimum power that a single channel must have compared to the total signal in order to be regarded as an active channel. Channels below the specified threshold are regarded as "inactive".

Parameters:

<ThresholdLevel> Range: -100 dB to 0 dB
 *RST: -60 dB
 Default unit: DB

Example: SENS:CDP:ICTR -100

Mode: BTS application only

Manual operation: See "Inactive Channel Threshold (BTS measurements only)"
 on page 92

11.5.7.2 Managing channel tables

CONFigure:WCDPower[:BTS]:CTABLE[:STATE]	209
CONFigure:WCDPower[:BTS]:CTABLE:CATalog	209
CONFigure:WCDPower[:BTS]:CTABLE:COPI	210
CONFigure:WCDPower[:BTS]:CTABLE:DELe	211
CONFigure:WCDPower[:BTS]:CTABLE:SELe	211
CONFigure:WCDPower:MS:CTABLE[:STATE]	211
CONFigure:WCDPower:MS:CTABLE:CATalog	212
CONFigure:WCDPower:MS:CTABLE:COPI	212
CONFigure:WCDPower:MS:CTABLE:DELe	212
CONFigure:WCDPower:MS:CTABLE:SELe	213

CONFigure:WCDPower[:BTS]:CTABLE[:STATE] <State>

Switches the channel table on or off. When switched on, the measured channel table is stored under the name "RECENT" and is selected for use. After the "RECENT" channel table is switched on, another channel table can be selected with the command `CONFigure:WCDPower[:BTS]:CTABLE:SELe` on page 211.

Parameters:

<State> ON | OFF | 1 | 0
 *RST: 0

Example: CONF:WCDP:CTAB ON

Mode: BTS application only

Manual operation: See "Using Predefined Channel Tables" on page 93

CONFigure:WCDPower[:BTS]:CTABLE:CATalog

Reads out the names of all channel tables stored in the instrument. The first two result values are global values for all channel tables, the subsequent values are listed for each individual table.

Configuring code domain analysis and time alignment error measurements

Parameters:

<TotalSize>	Sum of file sizes of all channel table files (in bytes)
<FreeMem>	Available memory left on hard disk (in bytes)
<FileName>	File name of individual channel table file
<FileSize>	File size of individual channel table file (in bytes)

Example:

```
CONF:WCDP:CTAB:CAT?
```

Sample result (description see table below):

```
52853,2634403840,3GB_1_16.XML,
3469,3GB_1_32.XML,5853,3GB_1_64.XML,
10712,3GB_2.XML,1428,3GB_3_16.XML,
3430,3GB_3_32.XML,5868,3GB_4.XML,
678,3GB_5_2.XML,2554,3GB_5_4.XML,
4101,3GB_5_8.XML,7202,3GB_6.XML,
7209,MYTABLE.XML,349
```

Mode: BTS application only

Manual operation: See "Predefined Tables" on page 93

Table 11-6: Description of query results in example:

Value	Description
52853	Total size of all channel table files: 52583 bytes
2634403840	Free memory on hard disk: 2.6 Gbytes
3GB_1_16.XML	Channel table 1: 3GB_1_16.XML
3469	File size for channel table 1: 3469 bytes
3GB_1_32.XML	Channel table 2: 3GB_1_32.XML
5853	File size for channel table 2: 5853 bytes
3GB_1_64.XML	Channel table 3: 3GB_1_64.XML
10712	File size for channel table 3: 10712 bytes
...	Channel table x: ...

CONFigure:WCDPower[:BTS]:CTable:COPY <FileName>

Copies one channel table onto another one. The channel table to be copied is selected with command **CONFigure:WCDPower[:BTS]:CTable:NAME** on page 214.

The name of the channel table may contain a maximum of 8 characters.

Parameters:

<FileName> name of the new channel table

Example:

```
CONF:WCDP:CTAB:NAME 'NEW_TAB'
```

Defines the channel table name to be copied.

```
CONF:WCDP:CTAB:COPY 'CTAB_2'
```

Copies channel table 'NEW_TAB' to 'CTAB_2'.

Mode: BTS application only

Manual operation: See ["Copying a Table"](#) on page 94

CONFigure:WCDPower[:BTS]:CTABLE:DELeTe

Deletes the selected channel table. The channel table to be deleted is selected with the command [CONFigure:WCDPower\[:BTS\]:CTABLE:NAME](#) on page 214.

Example:

```
CONF:WCDP:CTAB:NAME 'NEW_TAB'
```

Defines the channel table name to be deleted.

```
CONF:WCDP:CTAB:DEL
```

Deletes the table.

Mode: BTS application only

Manual operation: See ["Deleting a Table"](#) on page 94

CONFigure:WCDPower[:BTS]:CTABLE:SELEct <FileName>

Selects a predefined channel table file for comparison during channel detection. Before using this command, the "RECENT" channel table must be switched on first with the command [CONFigure:WCDPower\[:BTS\]:CTABLE\[:STATe\]](#) on page 209.

Parameters:

<FileName> *RST: RECENT

Example:

```
CONF:WCDP:CTAB ON
```

Switches the channel table on.

```
CONF:WCDP:CTAB:SEL 'CTAB_1'
```

Selects the predefined channel table 'CTAB_1'.

Mode: BTS application only

Manual operation: See ["Selecting a Table"](#) on page 94

CONFigure:WCDPower:MS:CTABLE[:STATe] <State>

Switches the channel table on or off. When switched on, the measured channel table is stored under the name "RECENT" and is selected for use. After the "RECENT" channel table is switched on, another channel table can be selected with the command [CONFigure:WCDPower\[:BTS\]:CTABLE:SELEct](#) on page 211.

Parameters:

<State> ON | OFF | 1 | 0

*RST: 0

Example:

```
CONF:WCDP:CTAB ON
```

Mode: UE application only

Manual operation: See ["Using Predefined Channel Tables"](#) on page 93

CONFigure:WCDPower:MS:CTABLE:CATalog

Reads out the names of all channel tables stored in the instrument. The first two result values are global values for all channel tables, the subsequent values are listed for each individual table.

Parameters:

<TotalSize>	Sum of file sizes of all channel table files (in bytes)
<FreeMem>	Available memory left on hard disk (in bytes)
<FileName>	File name of individual channel table file
<FileSize>	File size of individual channel table file (in bytes)

Mode: UE application only

Manual operation: See ["Predefined Tables"](#) on page 93

CONFigure:WCDPower:MS:CTABLE:COPY <FileName>

Copies one channel table onto another one. The channel table to be copied is selected with command [CONFigure:WCDPower:MS:CTABLE:NAME](#) on page 214.

The name of the channel table may contain a maximum of 8 characters.

Parameters:

<FileName>	Name of the new channel table
------------	-------------------------------

Example:

```
CONF:WCDP:MS:CTAB:NAME 'NEW_TAB'
Defines the channel table name to be copied.
CONF:WCDP:MS:CTAB:COPY 'CTAB_2'
Copies channel table 'NEW_TAB' to 'CTAB_2'.
```

Mode: UE application only

Manual operation: See ["Copying a Table"](#) on page 94

CONFigure:WCDPower:MS:CTABLE:DELeTe

Deletes the selected channel table. The channel table to be deleted is selected with the command [CONFigure:WCDPower:MS:CTABLE:NAME](#) on page 214.

Example:

```
CONF:WCDP:MS:CTAB:NAME 'NEW_TAB'
Defines the channel table name to be deleted.
CONF:WCDP:MS:CTAB:DEL
```

Mode: UE application only

Manual operation: See ["Deleting a Table"](#) on page 94

CONFigure:WCDPower:MS:CTABLE:SElect <FileName>

Selects a predefined channel table file for comparison during channel detection. Before using this command, the "RECENT" channel table must be switched on first with the command [CONFigure:WCDPower:MS:CTABLE\[:STATe\]](#) on page 211.

Parameters:

<FileName> *RST: RECENT

Example:

```
CONF:WCDP:MS:CTAB1 ON
Switches the channel table on.
CONF:WCDP:CTAB:MS:SEL 'CTAB_1'
Selects the predefined channel table 'CTAB_1'.
```

Mode: UE application only

Manual operation: See "[Selecting a Table](#)" on page 94

11.5.7.3 Configuring channel tables

Some general settings and functions are available when configuring a predefined channel table.

Remote commands exclusive to configuring channel tables:

CONFigure:WCDPower[:BTS]:CTABLE:COMMeNT	213
CONFigure:WCDPower[:BTS]:CTABLE:MTABLE	214
CONFigure:WCDPower[:BTS]:CTABLE:NAME	214
CONFigure:WCDPower:MS:CTABLE:NAME	214
CONFigure:WCDPower:MS:CTABLE:COMMeNT	214
CONFigure:WCDPower:MS:CTABLE:MTABLE	215

CONFigure:WCDPower[:BTS]:CTABLE:COMMeNT <Comment>

Defines a comment for the selected channel table:

Prior to this command, the name of the channel table has to be defined with command [CONFigure:WCDPower\[:BTS\]:CTABLE:NAME](#) on page 214. The values of the table are defined with command [CONFigure:WCDPower\[:BTS\]:CTABLE:DATA](#) on page 215.

Parameters:

<Comment>

Example:

```
CONF:WCDP:CTAB:NAME 'NEW_TAB'
Defines the channel table name.
CONF:WCDP:CTAB:COMM 'Comment for table 1'
Defines a comment for the table.
CONF:WCDP:CTAB:DATA
8,0,0,0,0,0,1,0.00,8,1,0,0,0,0,1,0.00,7,1,0,
256,8,0,1,0.00
Defines the table values.
```

Mode: BTS application only

Manual operation: See ["Comment"](#) on page 95

CONFigure:WCDPower[:BTS]:CTABLE:MTABLE

Creates a completely new channel table according to the current measurement data.

Example: `CONF:WCDP:BTS:CTAB:MTAB`

Usage: Event

Manual operation: See ["Creating a New Channel Table from the Measured Signal \(Measure Table\)"](#) on page 95

CONFigure:WCDPower[:BTS]:CTABLE:NAME <Name>

Creates a new channel table file or selects an existing channel table in order to copy or delete it.

Parameters:

<Name> <file name>

*RST: RECENT

Example: `CONF:WCDP:CTAB:NAME 'NEW_TAB'`

Mode: BTS application only

Manual operation: See ["Name"](#) on page 95

CONFigure:WCDPower:MS:CTABLE:NAME <FileName>

Creates a new channel table file or selects an existing channel table in order to copy or delete it.

Parameters:

<FileName> *RST: RECENT

Example: `CONF:WCDP:CTAB:NAME 'NEW_TAB'`

Mode: UE application only

Manual operation: See ["Name"](#) on page 95

CONFigure:WCDPower:MS:CTABLE:COMMeNT <Comment>

Defines a comment for the selected channel table:

Prior to this command, the name of the channel table has to be defined with command [CONFigure:WCDPower:MS:CTABLE:NAME](#) on page 214. The values of the table are defined with command [CONFigure:WCDPower:MS:CTABLE:DATA](#) on page 216.

Parameters:

<Comment>

Configuring code domain analysis and time alignment error measurements

- Example:** `CONF:WCDP:MS:CTAB:NAME 'NEW_TAB'`
 Defines the channel table name.
`CONF:WCDP:MS:CTAB:COMM 'Comment for table 1'`
 Defines a comment for the table.
- Mode:** UE application only
- Manual operation:** See ["Comment"](#) on page 95

CONFigure:WCDPower:MS:CTABLE:MTABLE

Creates a completely new channel table according to the current measurement data.

Example: `CONF:WCDP:MS:CTAB:MTAB`

Manual operation: See ["Creating a New Channel Table from the Measured Signal \(Measure Table\)"](#) on page 95

11.5.7.4 Configuring channel details (BTS measurements)

The following commands are used to configure individual channels in a predefined channel table in BTS measurements.

[CONFigure:WCDPower\[:BTS\]:CTABLE:DATA](#)..... 215

CONFigure:WCDPower[:BTS]:CTABLE:DATA {<CodeClass>, <CodeNumber>}...

Defines or queries the values of the selected channel table. Each line of the table consists of 8 values.

Channels PICH, CPICH and PCCPCH may only be defined once. If channel CPICH or PCCPCH is missing in the command, it is automatically added at the end of the table.

Prior to this command, the name of the channel table has to be defined with the command [CONFigure:WCDPower\[:BTS\]:CTABLE:NAME](#) on page 214 .

Parameters:

<CodeClass>	Range: 2 to 9
<CodeNumber>	Range: 0 to 511
<UseTFCI>	0 1 0 not used 1 used
<TimingOffset>	Step width: 256; for code class 9: 512 Range: 0 to 38400
<PilotLength>	code class 9: 4 code class 8: 2,4, 8 code class 7: 4, 8 code class 5/6: 8

Configuring code domain analysis and time alignment error measurements

	code class 2/3/4: 16
<ChannelType>	For the assignment of channel types to parameters see Table 11-4 .
<Status>	0 not active 1 active
<CDP>	for queries: CDP relative to total signal power; for settings: CDP absolute or relative

Example: CONF:WCDP:CTAB:NAME 'NEW_TAB'
Defines the channel table name.
CONF:WCDP:CTAB:DATA
8,0,0,0,0,0,1,0.00,8,1,0,0,0,0,1,0.00,7,1,0,
256,8,0,1,0.00

Mode: BTS application only

Manual operation: See "[Channel Type](#)" on page 97
See "[Channel Number \(Ch. SF\)](#)" on page 97
See "[Use TFCI](#)" on page 97
See "[Timing Offset](#)" on page 97
See "[Pilot Bits](#)" on page 97
See "[CDP Relative](#)" on page 97
See "[State](#)" on page 98

11.5.7.5 Configuring channel details (UE measurements)

The following commands are used to configure individual channels in a predefined channel table in UE measurements.

CONFigure:WCDPower:MS:CTABLE:DATA.....	216
CONFigure:WCDPower:MS:CTABLE:DATA:HSDPcch.....	217
CONFigure:WCDPower:MS:CTABLE:EDATa.....	217
CONFigure:WCDPower:MS:CTABLE:EDATa:EDPCch.....	218

CONFigure:WCDPower:MS:CTABLE:DATA {<CodeClass>, <NoActChan>, <PilotLength>}...

Defines the values of the selected channel table.

The Channel DPCCH may only be defined once. If channel DPCCH is missing in the command data, it is automatically added at the end of the table. Prior to this command, the name of the channel table has to be defined with the command [CONFigure:WCDPower:MS:CTABLE:NAME](#) on page 214.

Parameters:

<CodeClass> Code class of channel 1. I-mapped
Range: 2 to 9

Configuring code domain analysis and time alignment error measurements

<NoActChan>	Number of active channels Range: 1 to 7
<PilotLength>	pilot length of channel DPCCH
<CodeClass>	Code class of channel 1. I-mapped Range: 2 to 9
<NoActChan>	Number of active channels Range: 1 to 7
<PilotLength>	pilot length of channel DPCCH
<CDP1>	Measured relative code domain power values of channel 1
<CDP2>	Measured relative code domain power values of channel 2
<CDP3>	Measured relative code domain power values of channel 3
<CDP4>	Measured relative code domain power values of channel 4
<CDP5>	Measured relative code domain power values of channel 5
<CDP6>	Measured relative code domain power values of channel 6

Example:

```
CONF:WCDP:MS:CTAB:DATA 8,0,0,5,1,0.00,
4,1,1,0,1,0.00, 4,1,0,0,1,0.00
```

The following channels are defined: DPCCH and two data channels with 960 ksps.

Mode: UE application only

Manual operation: See "[Channel Type](#)" on page 97
 See "[Channel Number \(Ch. SF\)](#)" on page 97
 See "[Pilot Bits](#)" on page 97
 See "[CDP Relative](#)" on page 97
 See "[State](#)" on page 98

CONFigure:WCDPower:MS:CTABLE:DATA:HSDPcch <State>

Activates or deactivates the HS-DPCCH entry in a predefined channel table.

Parameters:

<State> *RST: ON

Example: CONF:WCDP:MS:CTAB:DATA:HSDP ON

Mode: UE application only

CONFigure:WCDPower:MS:CTABLE:EDATa {<CodeClass>, <NoActChan>}...

Defines the values for an E-DPCCH channel in the selected channel table. The channel table must be selected using the command [CONFigure:WCDPower:MS:CTABLE:NAME](#) on page 214.

Configuring code domain analysis and time alignment error measurements

Parameters:

<CodeClass>	Code class of channel Range: 2 to 9
<NoActChan>	Number of active channels Range: 0 to 4
<CodeClass>	Code class of channel Range: 2 to 9
<NoActChan>	Number of active channels Range: 0 to 4
<ECDP1>	Measured relative code domain power values of channel 1
<ECDP2>	Measured relative code domain power values of channel 2
<ECDP3>	Measured relative code domain power values of channel 3
<ECDP4>	Measured relative code domain power values of channel 4

Example: `CONF:WCDP:MS:CTAB:EDAT 8,3`

Mode: UE application only

CONFigure:WCDPower:MS:CTABle:EDATa:EDPCch <arg0>

Activates or deactivates the E-DPCCH entry in a predefined channel table.

Parameters:

<State> *RST: OFF

Example: `CONF:WCDP:MS:CTAB:EDAT:EDPC ON`

Mode: UE application only

11.5.8 Sweep settings

[SENSe:]AVERage<n>:COUNT.....	218
[SENSe:]SWEep:COUNT.....	219

[SENSe:]AVERage<n>:COUNT <AverageCount>

Defines the number of measurements that the application uses to average traces.

In case of continuous sweep mode, the application calculates the moving average over the average count.

In case of single sweep mode, the application stops the measurement and calculates the average after the average count has been reached.

Suffix:

<n> irrelevant

Configuring code domain analysis and time alignment error measurements

Parameters:

<AverageCount> If you set an average count of 0 or 1, the application performs one single measurement in single sweep mode.
In continuous sweep mode, if the average count is set to 0, a moving average over 10 measurements is performed.

Range: 0 to 200000
*RST: 0

Manual operation: See "[Sweep/Average Count](#)" on page 99

[SENSe:]SWEep:COUNT <SweepCount>

Defines the number of measurements that the application uses to average traces.

In continuous measurement mode, the application calculates the moving average over the average count.

In single measurement mode, the application stops the measurement and calculates the average after the average count has been reached.

Parameters:

<SweepCount> When you set a sweep count of 0 or 1, the FSW performs one single measurement in single measurement mode.
In continuous measurement mode, if the sweep count is set to 0, a moving average over 10 measurements is performed.

Range: 0 to 200000
*RST: 0

Example:

```
SWE:COUN 64
Sets the number of measurements to 64.
INIT:CONT OFF
Switches to single measurement mode.
INIT;*WAI
Starts a measurement and waits for its end.
```

Manual operation: See "[Sweep/Average Count](#)" on page 99

11.5.9 Automatic settings

**MSRA operating mode**

In MSRA operating mode, the following commands are not available, as they require a new data acquisition. However, 3GPP FDD applications cannot perform data acquisition in MSRA operating mode.

Useful commands for adjusting settings automatically described elsewhere:

- [DISPlay\[:WINDow<n>\]\[:SUBWindow<w>\]:TRACe<t>:Y\[:SCALE\]:AUTO ONCE](#) on page 190
- [\[SENSe:\]CDPower:LCODE:SEARCh\[:IMMediate\]](#) on page 162

Remote commands exclusive to adjusting settings automatically:

<code>CONFigure:WCDPower[:BTS]:AScale:STATe</code>	220
<code>CONFigure:WCDPower[:BTS]:MCARier:STATe</code>	220
<code>[SENSe:]ADJust:ALL</code>	220
<code>[SENSe:]ADJust:CONFigure:LEVel:DURation</code>	221
<code>[SENSe:]ADJust:CONFigure:LEVel:DURation:MODE</code>	221
<code>[SENSe:]ADJust:CONFigure:HYSteresis:LOWer</code>	222
<code>[SENSe:]ADJust:CONFigure:HYSteresis:UPPer</code>	222
<code>[SENSe:]ADJust:LEVel</code>	222

CONFigure:WCDPower[:BTS]:AScale:STATe <State>

Activate this command if multiple carriers are used. In this case, the autoscaling function automatically changes the level settings if the center frequency is changed to another carrier.

Parameters:

<State> ON | OFF | 1 | 0
*RST: 1

Example: `CONF:WCDP:ASC:STAT ON`

Mode: BTS application only

CONFigure:WCDPower[:BTS]:MCARier:STATe <State>

Activate this command if multiple carriers are used. In this case, the adjust reference level procedure ensures that the settings of RF attenuation and reference level are optimally adjusted for measuring a multicarrier signal.

Parameters:

<State> ON | OFF | 1 | 0
*RST: 0

Example: `CONF:WCDP:MCAR:STAT ON`

Mode: BTS application only

[SENSe:]ADJust:ALL

Initiates a measurement to determine and set the ideal settings for the current task automatically (only once for the current measurement).

This includes:

- Reference level
- Scrambling code
- Scaling

Example: `ADJ:ALL`

Manual operation: See ["Adjusting all Determinable Settings Automatically \(Auto All\)"](#) on page 100

[SENSe:]ADJust:CONFigure:LEVel:DURation <Duration>

To determine the ideal reference level, the FSW performs a measurement on the current input data. This command defines the length of the measurement if [\[SENSe:\]ADJust:CONFigure:LEVel:DURation:MODE](#) is set to `MANual`.

Parameters:

<Duration> Numeric value in seconds
 Range: 0.001 to 16000.0
 *RST: 0.001
 Default unit: s

Example:

```
ADJ:CONF:DUR:MODE MAN
Selects manual definition of the measurement length.
ADJ:CONF:LEV:DUR 5ms
Length of the measurement is 5 ms.
```

Manual operation: See ["Changing the Automatic Measurement Time \(Meas Time Manual\)"](#) on page 101

[SENSe:]ADJust:CONFigure:LEVel:DURation:MODE <Mode>

To determine the ideal reference level, the FSW performs a measurement on the current input data. This command selects the way the FSW determines the length of the measurement .

Parameters:

<Mode> **AUTO**
 The FSW determines the measurement length automatically according to the current input data.
 MANual
 The FSW uses the measurement length defined by [\[SENSe:\]ADJust:CONFigure:LEVel:DURation](#) on page 221.
 *RST: AUTO

Manual operation: See ["Resetting the Automatic Measurement Time \(Meas Time Auto\)"](#) on page 101
 See ["Changing the Automatic Measurement Time \(Meas Time Manual\)"](#) on page 101

[SENSe:]ADJust:CONFigure:HYSTeresis:LOWer <Threshold>

When the reference level is adjusted automatically using the [\[SENSe:\]ADJust:LEVel](#) on page 222 command, the internal attenuators and the preamplifier are also adjusted. To avoid frequent adaptation due to small changes in the input signal, you can define a hysteresis. This setting defines a lower threshold the signal must fall below (compared to the last measurement) before the reference level is adapted automatically.

Parameters:

<Threshold> Range: 0 dB to 200 dB
 *RST: +1 dB
 Default unit: dB

Example:

SENS:ADJ:CONF:HYST:LOW 2

For an input signal level of currently 20 dBm, the reference level is only adjusted when the signal level falls below 18 dBm.

Manual operation: See "[Lower Level Hysteresis](#)" on page 102

[SENSe:]ADJust:CONFigure:HYSTeresis:UPPer <Threshold>

When the reference level is adjusted automatically using the [\[SENSe:\]ADJust:LEVel](#) on page 222 command, the internal attenuators and the preamplifier are also adjusted. To avoid frequent adaptation due to small changes in the input signal, you can define a hysteresis. This setting defines an upper threshold the signal must exceed (compared to the last measurement) before the reference level is adapted automatically.

Parameters:

<Threshold> Range: 0 dB to 200 dB
 *RST: +1 dB
 Default unit: dB

Example:

SENS:ADJ:CONF:HYST:UPP 2

Example:

For an input signal level of currently 20 dBm, the reference level is only adjusted when the signal level rises above 22 dBm.

Manual operation: See "[Upper Level Hysteresis](#)" on page 102

[SENSe:]ADJust:LEVel

Initiates a single (internal) measurement that evaluates and sets the ideal reference level for the current input data and measurement settings. Thus, the settings of the RF attenuation and the reference level are optimized for the signal level. The FSW is not overloaded and the dynamic range is not limited by an S/N ratio that is too small.

Example:

ADJ:LEV

Manual operation: See "[Setting the Reference Level Automatically \(Auto Level\)](#)" on page 76

11.5.10 Evaluation range

The evaluation range defines which data is evaluated in the result display.

[SENSe:]CDPower:CODE.....	223
[SENSe:]CDPower:FRAMe[:VALue].....	223
[SENSe:]CDPower:SLOT.....	223
[SENSe:]CDPower:MAPPING.....	223
CALCulate<n>:CDPower:MAPPING.....	224

[SENSe:]CDPower:CODE <CodeNumber>

Sets the code number. The code number refers to code class 9 (spreading factor 512).

Parameters:

<CodeNumber> *RST: 0

Example: SENS:CDP:CODE 30

Manual operation: See "[Channel](#)" on page 115

[SENSe:]CDPower:FRAMe[:VALue] <Frame>

Defines the frame to be analyzed within the captured data.

Parameters:

<Frame> Range: [0 ... CAPTURE_LENGTH – 1]
*RST: 1

Example: CDP:FRAM:VAL 1

Manual operation: See "[Time Alignment Error](#)" on page 35
See "[Frame To Analyze](#)" on page 88

[SENSe:]CDPower:SLOT <SlotNumber>

Selects the (CPICH) slot number to be evaluated.

Parameters:

<SlotNumber> *RST: 0

Example: SENS:CDP:SLOT 3

Manual operation: See "[\(CPICH\) Slot](#)" on page 116

[SENSe:]CDPower:MAPPING <SignalBranch>

Switches between I and Q branches of the signal for all evaluations (if not specified otherwise using [CALCulate<n>:CDPower:MAPPING](#) on page 224).

Parameters:

<SignalBranch> I | Q
*RST: Q

Configuring code domain analysis and time alignment error measurements

Example:	CDP:MAPP Q
Mode:	UE application only
Manual operation:	See "Branch (UE measurements only)" on page 116 See "Selecting a Different Branch for a Window" on page 117

CALCulate<n>:CDPower:MAPPING <SignalBranch>

Adjusts the mapping for the evaluations "Code Domain Power" and "Code Domain Error Power" in a specific window.

Suffix:

<n> 1..n

Parameters:

<SignalBranch> I | Q | AUTO

I

The I-branch of the signal will be used for evaluation

Q

The Q-branch of the signal will be used for evaluation

AUTO

The branch selected by the [SENSe:]CDPower:MAPPING on page 223 command will be used for evaluation.

*RST: AUTO

Example: CALC:CDP:MAPP AUTO

Mode: UE application only

11.5.11 Code domain analysis settings (BTS measurements)

Some evaluations provide further settings for the results. The commands for BTS measurements are described here.

CALCulate<n>:MARKer<m>:FUNCTion:ZOOM.....	224
[SENSe:]CDPower:CPB.....	225
[SENSe:]CDPower:NORMALize.....	225
[SENSe:]CDPower:PDISplay.....	225
[SENSe:]CDPower:PDIFf.....	226
[SENSe:]CDPower:PREFerence.....	226

CALCulate<n>:MARKer<m>:FUNCTion:ZOOM <State>

If marker zoom is activated, the number of channels displayed on the screen in the code domain power and code domain error power result diagram is reduced to 64.

The currently selected marker defines the center of the displayed range.

Suffix:

<n> 1..n

Configuring code domain analysis and time alignment error measurements

<m> 1..n
Marker

Parameters:

<State> ON | OFF | 1 | 0
*RST: 0

Example: CALC:MARK:FUNC:ZOOM ON

[SENSe:]CDPower:CPB <Value>

Selects the constellation parameter B. According to 3GPP specification, the mapping of 16QAM symbols to an assigned bit pattern depends on the constellation parameter B.

Parameters:

<Value> *RST: 0

Example: SENS:CDP:CDP 1

Manual operation: See "[Constellation Parameter B](#)" on page 119

[SENSe:]CDPower:NORMalize <State>

If enabled, the I/Q offset is eliminated from the measured signal. This is useful to deduct a DC offset to the baseband caused by the DUT, thus improving the EVM. Note, however, that for EVM measurements according to standard, compensation must be disabled.

Parameters:

<State> ON | OFF | 1 | 0
*RST: 0

Example: SENS:CDP:NORM ON
Activates the elimination of the I/Q offset.

Manual operation: See "[Compensate IQ Offset](#)" on page 118

[SENSe:]CDPower:PDISplay <Mode>

Switches between showing the absolute or relative power.

This parameter only affects the "Code Domain Power" evaluation.

Parameters:

<Mode> ABS | REL
ABSolute
Absolute power levels

RELative

Power levels relative to total signal power or (BTS application only) CPICH channel power (see [\[SENSe:\]CDPower:PREference](#) on page 226)

Configuring code domain analysis and time alignment error measurements

*RST: ABS

Example: SENS:CDP:PDIS ABS

Manual operation: See ["Code Power Display"](#) on page 118
See ["Code Power Display"](#) on page 120

[SENSe:]CDPower:PDIFf <State>

Defines which slot power difference is displayed in the "Power vs Slot" evaluation.

Parameters:

<State> ON | OFF | 1 | 0

ON | 1

The slot power difference to the previous slot is displayed.

OFF | 0

The current slot power of each slot is displayed.

*RST: 0

Example: SENS:CDP:PDIF ON

Mode: BTS application only

Manual operation: See ["Show Difference to Previous Slot"](#) on page 118

[SENSe:]CDPower:PREFERENCE <Mode>

Defines the reference for the relative CDP measurement values.

Parameters:

<Mode> TOTal | CPICH | PICH

TOTal

Total signal power

CPICH

CPICH channel power

*RST: TOTal

Example: SENS:CDP:PREF CPIC

Mode: BTS application only

Manual operation: See ["Code Power Display"](#) on page 118

11.5.12 Code domain analysis settings (UE measurements)

Some evaluations provide further settings for the results. The commands for UE measurements are described here.

Useful commands for Code Domain Analysis described elsewhere:

- [CALCulate<n>:MARKer<m>:FUNction:ZOOM](#) on page 224
- [\[SENSe:\]CDPower:NORMALize](#) on page 225

- [\[SENSe:\]CDPower:PDISplay](#) on page 225

Remote commands exclusive to Code Domain Analysis in UE Measurements:

[SENSe:]CDPower:ETCHips	227
[SENSe:]CDPower:HSLot	227

[SENSe:]CDPower:ETCHips <State>

Selects length of the measurement interval for calculation of error vector magnitude (EVM). In accordance with 3GPP specification Release 5, the EVM measurement interval is one slot (4096 chips) minus 25 μ s (3904 chips) at each end of the burst if power changes are expected. If no power changes are expected, the evaluation length is one slot (4096 chips).

Parameters:

<State>

ON | 1

Changes of power are expected. Therefore an EVM measurement interval of one slot minus 25 μ s (3904 chips) is considered.

OFF | 0

Changes of power are not expected. Therefore an EVM measurement interval of one slot (4096 chips) is considered

*RST: 0

Example: SENS:CDP:ETCH ON

Manual operation: See "[Eliminate Tail Chips](#)" on page 120

[SENSe:]CDPower:HSLot <State>

Switches between the analysis of half slots and full slots.

Parameters:

<State>

ON | OFF | 1 | 0

ON | 1

30 (half) slots are evaluated

OFF | 0

15 (full) slots are evaluated

*RST: 0

Example: SENS:CDP:HSL ON

Mode: UE application only

Manual operation: See "[Measurement Interval](#)" on page 119

11.5.13 Configuring carrier tables for time alignment measurements

The following commands are required to configure carrier tables for TAE measurements (see [Chapter 5.3.2, "Carrier table configuration"](#), on page 104)

Configuring code domain analysis and time alignment error measurements

[SENSe:]TAERror:CARRier<c>:ANTenna<antenna>:CPICH.....	228
[SENSe:]TAERror:CARRier<c>:ANTenna<antenna>:PATtern.....	228
[SENSe:]TAERror:CARRier<c>:COUNT.....	229
[SENSe:]TAERror:CARRier<c>:DELeTe.....	229
[SENSe:]TAERror:CARRier<c>:INSert.....	229
[SENSe:]TAERror:CARRier<c>:OFFSet.....	230
[SENSe:]TAERror:CARRier<c>:SCODE.....	230
[SENSe:]TAERror:CATalog.....	231
[SENSe:]TAERror:DELeTe.....	231
[SENSe:]TAERror:NEW.....	231
[SENSe:]TAERror:PRESet.....	231
[SENSe:]TAERror:SAVE.....	232

[SENSe:]TAERror:CARRier<c>:ANTenna<antenna>:CPICH <CodeNumber>

Defines or queries the CPICH of the specified antenna for the carrier specified by the CARRier<c> suffix in the currently selected carrier table for "Time Alignment Error" measurement.

For antenna 1, the value can be queried only, not defined.

Suffix:

<c>	1..n Carrier in carrier table The suffix must refer to a carrier already defined in the current table.
<antenna>	1..n Antenna to be configured or queried

Parameters:

<CodeNumber>	Scrambling code in decimal format. Range: 0 to 225 *RST: 0
--------------	--

Manual operation: See "[Antenna 1: CPICH-Number](#)" on page 108
See "[Antenna 2: CPICH-Number](#)" on page 108

[SENSe:]TAERror:CARRier<c>:ANTenna<antenna>:PATtern <Pattern>

Defines or queries the pattern of the specified antenna for the carrier specified by the CARRier<c> suffix in the currently selected carrier table for "Time Alignment Error" measurement.

For antenna 1, the value can be queried only, not defined.

Suffix:

<c>	1..n Carrier in carrier table The suffix must refer to a carrier already defined in the current table.
-----	--

Configuring code domain analysis and time alignment error measurements

<antenna> 1..n
Antenna to be configured or queried

Parameters:

<Pattern> PATTERN_1 | PATTERN_2 | NONE
*RST: antenna 1: PATTERN_1; antenna 2: PATTERN_2

Manual operation: See "[Antenna 1: CPICH-Pattern](#)" on page 108
See "[Antenna 2: CPICH-Pattern](#)" on page 108

[SENSe:]TAERror:CARRier<c>:COUNT

Queries the number of carriers defined in the currently selected carrier table for "Time Alignment Error" measurement.

Suffix:

<c> 1..n

Manual operation: See "[Carrier](#)" on page 107

[SENSe:]TAERror:CARRier<c>:DELete [<ALL>]

Deletes the carrier specified by the CARRier<c> suffix in the currently selected carrier table for "Time Alignment Error" measurement.

If the parameter ALL is used, the carrier suffix is ignored and all carriers except for the reference carrier are deleted.

Suffix:

<c> 1..n
Carrier in carrier table
The suffix must refer to a carrier already defined in the current table, but not to the reference carrier.

Parameters:

<ALL> ALL
All carriers except for the reference carrier are deleted.

Example: TAER:CARR2:DEL
Deletes carrier 2.

Example: TAER:CARR:DEL ALL
Deletes all carriers except for the reference carrier.

Manual operation: See "[Deleting a Carrier](#)" on page 106

[SENSe:]TAERror:CARRier<c>:INSert

Inserts a new carrier in the currently selected carrier table for "Time Alignment Error" measurement. The new carrier is inserted in the row specified by the CARRier<c> suffix.

Configuring code domain analysis and time alignment error measurements

Suffix:

<c> 1..n
Carrier in carrier table
The suffix must refer to a carrier already defined in the current table, or to the first row after the last defined carrier.

Manual operation: See ["Adding a Carrier"](#) on page 106

[SENSe:]TAERror:CARRier<c>:OFFSet <Freq>

Defines or queries the frequency offset of the carrier specified by the CARRier<c> suffix in the currently selected carrier table for "Time Alignment Error" measurement. The frequency offset is defined with respect to the reference carrier.

(The reference carrier is set to the current center frequency, thus the offset is always 0.)

Suffix:

<c> 1..n
Carrier in carrier table
The suffix must refer to a carrier already defined in the current table, but not to the reference carrier.

Parameters:

<Freq> The minimum spacing between two carriers is 2.5 MHz.
The maximum positive and negative frequency offset which a carrier can have from the reference depends on the available analysis bandwidth (see ["Frequency Offset"](#) on page 107).
Range: 2.5 MHz to +/- 61.5 MHz
Default unit: HZ

Manual operation: See ["Frequency Offset"](#) on page 107

[SENSe:]TAERror:CARRier<c>:SCODE <ScramblingCode>

Defines or queries the scrambling code of the carrier specified by the CARRier<c> suffix in the currently selected carrier table for "Time Alignment Error" measurement.

(The scrambling code for the reference carrier is defined/queried using [\[SENSe:\]CDPower:LCODE:DVALue](#) on page 164.)

Suffix:

<c> 1..n
Carrier in carrier table
The suffix must refer to a carrier already defined in the current table, but not the reference carrier.

Parameters:

<ScramblingCode> Scrambling code in decimal format.
*RST: 00

Manual operation: See ["Scrambling Code"](#) on page 108

[SENSe:]TAERror:CATalog

Lists the carrier table names of all carrier table files found in the default directory.

The default directory for carrier tables is

C:\R_SInstr\user\chan_tab\carrier_table\.

Parameters:

<Tablenames> Table names as a comma-separated list of strings

Example:

TAER:CAT?

Result: 'COPIED TABLE','NEWTABLE'

Manual operation: See "[Carrier Tables](#)" on page 104

[SENSe:]TAERror:DELeTe <Filename>

Deletes the specified carrier table for "Time Alignment Error" measurement.

Parameters:

<Filename> Filename of the carrier table to be deleted in the default directory.

The default directory for carrier tables is

C:\R_SInstr\user\chan_tab\carrier_table\.

Example:

TAER:DEL 'MyCarrierTable'

Deletes the file

C:\R_SInstr\user\chan_tab\carrier_table\
MyCarrierTable.xml.

Manual operation: See "[Deleting a Table](#)" on page 105

[SENSe:]TAERror:NEW

Creates a new carrier table for "Time Alignment Error" measurement.

Parameters:

<Filename> Filename of the new carrier table to be created in the default directory.

The default directory for carrier tables is

C:\R_SInstr\user\chan_tab\carrier_table\.

Example:

TAER:NEW 'MyCarrierTable'

Creates the file

C:\R_SInstr\user\chan_tab\carrier_table\
MyCarrierTable.xml.

Manual operation: See "[Creating a New Table](#)" on page 105

[SENSe:]TAERror:PRESet <Filename>

Loads the specified carrier table as the default table ("RECENT") for "Time Alignment Error" measurement.

Parameters:

<Filename> Filename of the stored carrier table.
The default directory for carrier tables is
C:\R_SInstr\user\chan_tab\carrier_table\.

Example:

```
TAER:PRES 'MyCarrierTable'
```

Loads the carrier table from the file
C:\R_SInstr\user\chan_tab\carrier_table\
MyCarrierTable.xml.

Manual operation: See ["Selecting a Table"](#) on page 104

[SENSe:]TAERror:SAVE <Filename>

Saves the specified carrier table for "Time Alignment Error" measurement to an xml file in the default directory.

Parameters:

<Filename> Filename of the new or edited carrier table.
The default directory for carrier tables is
C:\R_SInstr\user\chan_tab\carrier_table\.

Example:

```
TAER:SAVE 'MyCarrierTable'
```

Stores the file
C:\R_SInstr\user\chan_tab\carrier_table\
MyCarrierTable.xml.

Manual operation: See ["Saving the Table"](#) on page 106

11.6 Configuring RF measurements

RF measurements are performed in the Spectrum application, with some predefined settings as described in [Chapter 3.3, "RF measurements"](#), on page 35.

For details on configuring these RF measurements in a remote environment, see the Remote Commands chapter of the FSW User Manual.

The 3GPP FDD RF measurements must be activated for a 3GPP FDD application, see [Chapter 11.3, "Activating 3GPP FDD measurements"](#), on page 155.

The individual measurements are activated using the `CONFigure:WCDPower[:BTS]:MEASurement` on page 159 command (see [Chapter 11.4, "Selecting a measurement"](#), on page 159).

- [Special RF configuration commands](#)..... 233
- [Analysis](#).....233

11.6.1 Special RF configuration commands

In addition to the common RF measurement configuration commands described for the base unit, the following special commands are available in 3GPP FDD applications:

[CONFigure:WCDPower\[:BTS\]:STD](#).....233

CONFigure:WCDPower[:BTS]:STD <Type>

Switches between Normal mode and Home BS (Home Base Station) mode for ACP and SEM measurements in the BTS application. Switching this parameter changes the limits according to the specifications.

Parameters:

<Type> HOME | NORMAl
HOME
 Home Base Station
NORMAl
 Normal mode
 *RST: NORMAl

Example: CONF:WCDP:BTS:STD HOME

Mode: BTS application only

Manual operation: See "[BTS Standard](#)" on page 110

11.6.2 Analysis

General result analysis settings concerning the trace, markers, lines etc. for RF measurements are identical to the analysis functions in the Spectrum application except for some special marker functions and spectrograms, which are not available in the 3GPP FDD applications.

For details see the "General Measurement Analysis and Display" chapter in the FSW User Manual.

11.7 Configuring the result display

The following commands are required to configure the screen display in a remote environment. The tasks for manual operation are described in [Chapter 3, "Measurements and result display"](#), on page 16.

11.7.1	General window commands.....	234
11.7.2	Working with windows in the display.....	234

11.7.1 General window commands

The following commands are required to configure general window layout, independent of the application.

Note that the suffix <n> always refers to the window *in the currently selected channel* (see [INSTrument\[:SElect\]](#) on page 158).

DISPlay:FORMat	234
DISPlay[:WINDow<n>]:SIZE	234

DISPlay:FORMat <Format>

Determines which tab is displayed.

Parameters:

<Format>

SPLit

Displays the MultiView tab with an overview of all active channels

SINGle

Displays the measurement channel that was previously focused.

*RST: SING

Example:

DISP:FORM SPL

DISPlay[:WINDow<n>]:SIZE <Size>

Maximizes the size of the selected result display window *temporarily*. To change the size of several windows on the screen permanently, use the [LAY:SPL](#) command (see [LAYout:SPLitter](#) on page 239).

Suffix:

<n>

Window

Parameters:

<Size>

LARGE

Maximizes the selected window to full screen. Other windows are still active in the background.

SMALI

Reduces the size of the selected window to its original size. If more than one measurement window was displayed originally, these are visible again.

*RST: SMALI

Example:

DISP:WIND2:SIZE LARG

11.7.2 Working with windows in the display

The following commands are required to change the evaluation type and rearrange the screen layout for a channel as you do using the SmartGrid in manual operation. Since

the available evaluation types depend on the selected application, some parameters for the following commands also depend on the selected channel.

Note that the suffix <n> always refers to the window *in the currently selected channel*.

(See `INSTRUMENT[:SELECT]` on page 158).

<code>LAYout:ADD[:WINDow]?</code>	235
<code>LAYout:CATalog[:WINDow]?</code>	237
<code>LAYout:IDENtify[:WINDow]?</code>	237
<code>LAYout:MOVE[:WINDow]</code>	238
<code>LAYout:REMOve[:WINDow]</code>	238
<code>LAYout:REPLace[:WINDow]</code>	238
<code>LAYout:SPLitter</code>	239
<code>LAYout:WINDow<n>:ADD?</code>	240
<code>LAYout:WINDow<n>:IDENtify?</code>	241
<code>LAYout:WINDow<n>:REMOve</code>	241
<code>LAYout:WINDow<n>:REPLace</code>	241

`LAYout:ADD[:WINDow]?` <WindowName>, <Direction>, <WindowType>

Adds a window to the display in the active channel.

Is always used as a query so that you immediately obtain the name of the new window as a result.

To replace an existing window, use the `LAYout:REPLace[:WINDow]` command.

Query parameters:

<WindowName>	String containing the name of the existing window the new window is inserted next to. By default, the name of a window is the same as its index. To determine the name and index of all active windows, use the <code>LAYout:CATalog[:WINDow]?</code> query.
<Direction>	LEFT RIGHT ABOVE BELOW Direction the new window is added relative to the existing window.
<WindowType>	text value Type of result display (evaluation method) you want to add. See the table below for available parameter values.

Return values:

<NewWindowName> When adding a new window, the command returns its name (by default the same as its number) as a result.

Example:

```
LAY:ADD? '1',BEL,'XPOW:CDP:ABSolute'
```

Adds a "Code Domain Power" display below window 1.

Usage: Query only

Manual operation:	See "Bitstream" on page 19
	See "Channel Table" on page 20
	See "Code Domain Power" on page 22
	See "Code Domain Error Power" on page 23
	See "Composite Constellation" on page 23
	See "Composite EVM" on page 24
	See "EVM vs Chip" on page 25
	See "Frequency Error vs Slot" on page 26
	See "Magnitude Error vs Chip" on page 26
	See "Marker Table" on page 27
	See "Peak Code Domain Error" on page 28
	See "Phase Discontinuity vs Slot" on page 28
	See "Phase Error vs Chip" on page 29
	See "Power vs Slot" on page 30
	See "Power vs Symbol" on page 31
	See "Result Summary" on page 31
	See "Symbol Constellation" on page 32
	See "Symbol EVM" on page 32
	See "Symbol Magnitude Error" on page 33
	See "Symbol Phase Error" on page 33
	See "Diagram" on page 40
	See "Result Summary" on page 40
	See "Marker Peak List" on page 41

Table 11-7: <WindowType> parameter values for 3GPP FDD application

Parameter value	Window type
BITStream	"Bitstream"
CCONst	"Composite Constellation"
CDPower	"Code Domain Power"
CDEPower	"Code Domain Error Power"
CEVM	"Composite EVM"
CTABle	"Channel Table"
EVMChip	"EVM vs. Chip"
FESLot	"Frequency Error vs. Slot"
MECHip	"Magnitude Error vs. Chip"
MTABle	"Marker table"
PCDerror	"Peak Code Domain Error"
PDSLot	"Phase Discontinuity vs. Slot"
PECHip	"Phase Error vs. Chip"
PSLot	"Power vs. Slot"
PSYMBOL	"Power vs. Symbol"
RSUMmary	"Result Summary"

Parameter value	Window type
SCONst	"Symbol Constellation"
SEVM	"Symbol EVM"
SMERror	"Symbol Magnitude Error"
SPERror	"Symbol Phase Error"

LAYout:CATalog[:WINDow]?

Queries the name and index of all active windows in the active channel from top left to bottom right. The result is a comma-separated list of values for each window, with the syntax:

<WindowName_1>,<WindowIndex_1>..<WindowName_n>,<WindowIndex_n>

Return values:

<WindowName> string
 Name of the window.
 In the default state, the name of the window is its index.

<WindowIndex> **numeric value**
 Index of the window.

Example:

LAY:CAT?

Result:

'2',2,'1',1

Two windows are displayed, named '2' (at the top or left), and '1' (at the bottom or right).

Usage: Query only

LAYout:IDENTify[:WINDow]? <WindowName>

Queries the **index** of a particular display window in the active channel.

Note: to query the **name** of a particular window, use the [LAYout:WINDow<n>:IDENTify?](#) query.

Query parameters:

<WindowName> String containing the name of a window.

Return values:

<WindowIndex> Index number of the window.

Example:

LAY:IDEN:WIND? '2'

Queries the index of the result display named '2'.

Response:

2

Usage: Query only

LAYout:MOVE[:WINDow] <WindowName>, <WindowName>, <Direction>

Setting parameters:

<WindowName> String containing the name of an existing window that is to be moved.
By default, the name of a window is the same as its index. To determine the name and index of all active windows in the active channel, use the [LAYout:CATalog\[:WINDow\]?](#) query.

<WindowName> String containing the name of an existing window the selected window is placed next to or replaces.
By default, the name of a window is the same as its index. To determine the name and index of all active windows in the active channel, use the [LAYout:CATalog\[:WINDow\]?](#) query.

<Direction> LEFT | RIGHT | ABOVE | BELOW | REPLACE
Destination the selected window is moved to, relative to the reference window.

Example: `LAY:MOVE '4', '1', LEFT`
Moves the window named '4' to the left of window 1.

Example: `LAY:MOVE '1', '3', REPL`
Replaces the window named '3' by window 1. Window 3 is deleted.

Usage: Setting only

LAYout:REMOve[:WINDow] <WindowName>

Removes a window from the display in the active channel.

Setting parameters:

<WindowName> String containing the name of the window. In the default state, the name of the window is its index.

Example: `LAY:REM '2'`
Removes the result display in the window named '2'.

Usage: Setting only

LAYout:REPLace[:WINDow] <WindowName>, <WindowType>

Replaces the window type (for example from "Diagram" to "Result Summary") of an already existing window in the active channel while keeping its position, index and window name.

To add a new window, use the [LAYout:ADD\[:WINDow\]?](#) command.

Setting parameters:

<WindowName> String containing the name of the existing window.
By default, the name of a window is the same as its index. To determine the name and index of all active windows in the active channel, use the [LAYout:CATalog\[:WINDow\]?](#) query.

<WindowType> Type of result display you want to use in the existing window. See [LAYout:ADD\[:WINDow\]?](#) on page 235 for a list of available window types.

Example: LAY:REPL:WIND '1',MTAB
Replaces the result display in window 1 with a marker table.

Usage: Setting only

LAYout:SPLitter <Index1>, <Index2>, <Position>

Changes the position of a splitter and thus controls the size of the windows on each side of the splitter.

Compared to the [DISPlay\[:WINDow<n>\]:SIZE](#) on page 234 command, the [LAYout:SPLitter](#) changes the size of all windows to either side of the splitter permanently, it does not just maximize a single window temporarily.

Note that windows must have a certain minimum size. If the position you define conflicts with the minimum size of any of the affected windows, the command does not work, but does not return an error.

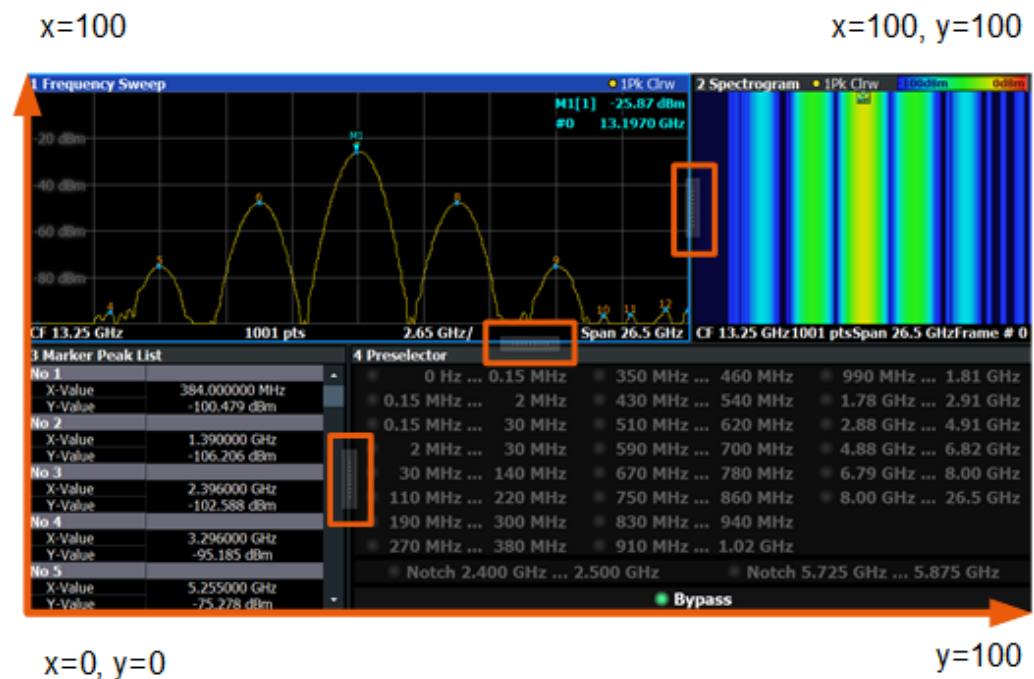

Figure 11-1: SmartGrid coordinates for remote control of the splitters

Setting parameters:

<Index1> The index of one window the splitter controls.

<Index2> The index of a window on the other side of the splitter.

<Position>	<p>New vertical or horizontal position of the splitter as a fraction of the screen area (without channel and status bar and softkey menu).</p> <p>The point of origin (x = 0, y = 0) is in the lower left corner of the screen. The end point (x = 100, y = 100) is in the upper right corner of the screen. (See Figure 11-1.)</p> <p>The direction in which the splitter is moved depends on the screen layout. If the windows are positioned horizontally, the splitter also moves horizontally. If the windows are positioned vertically, the splitter also moves vertically.</p> <p>Range: 0 to 100</p>
Example:	<pre>LAY:SPL 1,3,50</pre> <p>Moves the splitter between window 1 ('Frequency Sweep') and 3 ('Marker Table') to the center (50%) of the screen, i.e. in the figure above, to the left.</p>
Example:	<pre>LAY:SPL 1,4,70</pre> <p>Moves the splitter between window 1 ('Frequency Sweep') and 3 ('Marker Peak List') towards the top (70%) of the screen. The following commands have the exact same effect, as any combination of windows above and below the splitter moves the splitter vertically.</p> <pre>LAY:SPL 3,2,70 LAY:SPL 4,1,70 LAY:SPL 2,1,70</pre>
Usage:	Setting only

LAYout:WINDow<n>:ADD? <Direction>,<WindowType>

Adds a measurement window to the display. Note that with this command, the suffix <n> determines the existing window next to which the new window is added. Unlike [LAYout:ADD\[:WINDow\]?](#), for which the existing window is defined by a parameter.

To replace an existing window, use the [LAYout:WINDow<n>:REPLace](#) command.

Is always used as a query so that you immediately obtain the name of the new window as a result.

Suffix:

<n> [Window](#)

Query parameters:

<Direction> LEFT | RIGHT | ABOVE | BELOW

<WindowType> Type of measurement window you want to add.
See [LAYout:ADD\[:WINDow\]?](#) on page 235 for a list of available window types.

Return values:

<NewWindowName> When adding a new window, the command returns its name (by default the same as its number) as a result.

Example: LAY:WIND1:ADD? LEFT,MTAB
Result:
 '2'
 Adds a new window named '2' with a marker table to the left of window 1.

Usage: Query only

LAYout:WINDow<n>:IDENtify?

Queries the **name** of a particular display window (indicated by the <n> suffix) in the active channel.

Note: to query the **index** of a particular window, use the [LAYout:IDENtify\[:WINDow\]?](#) command.

Suffix:
 <n> [Window](#)

Return values:
 <WindowName> String containing the name of a window.
 In the default state, the name of the window is its index.

Example: LAY:WIND2:IDEN?
 Queries the name of the result display in window 2.
Response:
 '2'

Usage: Query only

LAYout:WINDow<n>:REMOve

Removes the window specified by the suffix <n> from the display in the active channel.

The result of this command is identical to the [LAYout:REMOve\[:WINDow\]](#) command.

Suffix:
 <n> [Window](#)

Example: LAY:WIND2:REM
 Removes the result display in window 2.

Usage: Event

LAYout:WINDow<n>:REPLace <WindowType>

Changes the window type of an existing window (specified by the suffix <n>) in the active channel.

The effect of this command is identical to the [LAYout:REPLace\[:WINDow\]](#) command.

To add a new window, use the [LAYout:WINDow<n>:ADD?](#) command.

Suffix:	
<n>	Window
Setting parameters:	
<WindowType>	Type of measurement window you want to replace another one with. See LAYout:ADD[:WINDow]? on page 235 for a list of available window types.
Example:	LAY:WIND2:REPL MTAB Replaces the result display in window 2 with a marker table.
Usage:	Setting only

11.8 Starting a measurement

The measurement is started immediately when a 3GPP FDD application is activated, however, you can stop and start a new measurement any time.

ABORt	242
INITiate<n>:CONMeas	243
INITiate<n>:CONTinuous	243
INITiate<n>[:IMMediate]	244
INITiate:SEQuencer:ABORt	244
INITiate:SEQuencer:IMMediate	244
INITiate:SEQuencer:MODE	245
INITiate:SEQuencer:REFResh[:ALL]	245
SYSTem:SEQuencer	246

ABORt

Aborts the measurement in the current channel and resets the trigger system.

To prevent overlapping execution of the subsequent command before the measurement has been aborted successfully, use the *OPC? or *WAI command after ABOR and before the next command.

For details on overlapping execution see [Remote control via SCPI](#).

To abort a sequence of measurements by the Sequencer, use the [INITiate:SEQuencer:ABORt](#) command.

Note on blocked remote control programs:

If a sequential command cannot be completed, for example because a triggered sweep never receives a trigger, the remote control program will never finish and the remote channel to the FSW is blocked for further commands. In this case, you must interrupt processing on the remote channel first in order to abort the measurement.

To do so, send a "Device Clear" command from the control instrument to the FSW on a parallel channel to clear all currently active remote channels. Depending on the used interface and protocol, send the following commands:

- **Visa:** `viClear()`
- **GPIB:** `ibclr()`
- **RSIB:** `RSDLLibclr()`

Now you can send the `ABORT` command on the remote channel performing the measurement.

Example: `ABOR; :INIT:IMM`
Aborts the current measurement and immediately starts a new one.

Example: `ABOR; *WAI`
`INIT:IMM`
Aborts the current measurement and starts a new one once abortion has been completed.

Usage: Event

INITiate<n>:CONMeas

Restarts a (single) measurement that has been stopped (using `ABORT`) or finished in single measurement mode.

The measurement is restarted at the beginning, not where the previous measurement was stopped.

As opposed to `INITiate<n>[:IMMEDIATE]`, this command does not reset traces in maxhold, minhold or average mode. Therefore it can be used to continue measurements using maxhold or averaging functions.

Suffix:
<n> irrelevant

Usage: Asynchronous command

Manual operation: See "[Continue Single Sweep](#)" on page 99

INITiate<n>:CONTinuous <State>

Controls the measurement mode for an individual channel.

Note that in single measurement mode, you can synchronize to the end of the measurement with `*OPC`, `*OPC?` or `*WAI`. In continuous measurement mode, synchronization to the end of the measurement is not possible. Thus, it is not recommended that you use continuous measurement mode in remote control, as results like trace data or markers are only valid after a single measurement end synchronization.

For details on synchronization see [Remote control via SCPI](#).

If the measurement mode is changed for a channel while the Sequencer is active (see [INITiate:SEQuencer:IMMEDIATE](#) on page 244), the mode is only considered the next time the measurement in that channel is activated by the Sequencer.

Suffix:

<n> irrelevant

Parameters:

<State> ON | OFF | 0 | 1

ON | 1

Continuous measurement

OFF | 0

Single measurement

*RST: 1 (some applications can differ)

Example:

```
INIT:CONT OFF
```

Switches the measurement mode to single measurement.

```
INIT:CONT ON
```

Switches the measurement mode to continuous measurement.

Manual operation: See "[Continuous Sweep / Run Cont](#)" on page 98

INITiate<n>[:IMMEDIATE]

Starts a (single) new measurement.

With measurement count or average count > 0, this means a restart of the corresponding number of measurements. With trace mode MAXHold, MINHold and AVERage, the previous results are reset on restarting the measurement.

You can synchronize to the end of the measurement with *OPC, *OPC? or *WAI.

For details on synchronization see [Remote control via SCPI](#).

Suffix:

<n> irrelevant

Usage:

Asynchronous command

Manual operation: See "[Single Sweep / Run Single](#)" on page 99

INITiate:SEQuencer:ABORt

Stops the currently active sequence of measurements.

You can start a new sequence any time using [INITiate:SEQuencer:IMMEDIATE](#) on page 244.

Usage:

Event

INITiate:SEQuencer:IMMEDIATE

Starts a new sequence of measurements by the Sequencer.

Its effect is similar to the [INITiate<n>\[:IMMEDIATE\]](#) command used for a single measurement.

Before this command can be executed, the Sequencer must be activated (see [SYSTem:SEQuencer](#) on page 246).

Example:

```
SYST:SEQ ON
Activates the Sequencer.
INIT:SEQ:MODE SING
Sets single sequence mode so each active measurement is performed once.
INIT:SEQ:IMM
Starts the sequential measurements.
```

INITiate:SEQuencer:MODE <Mode>

Defines the capture mode for the entire measurement sequence and all measurement groups and channels it contains.

Note: To synchronize to the end of a measurement sequence using *OPC, *OPC? or *WAI, use `SINGLE` Sequencer mode.

Parameters:

<Mode>

SINGLE

Each measurement group is started one after the other in the order of definition. All measurement channels in a group are started simultaneously and performed once. After *all* measurements are completed, the next group is started. After the last group, the measurement sequence is finished.

CONTInuous

Each measurement group is started one after the other in the order of definition. All measurement channels in a group are started simultaneously and performed once. After *all* measurements are completed, the next group is started. After the last group, the measurement sequence restarts with the first one and continues until it is stopped explicitly.

```
*RST:      CONTInuous
```

INITiate:SEQuencer:REFResh[:ALL]

Is only available if the Sequencer is deactivated ([SYSTem:SEQuencer](#) `SYST:SEQ:OFF`) and only in MSRA mode.

The data in the capture buffer is re-evaluated by all active MSRA secondary applications.

Example:

```

SYST:SEQ:OFF
Deactivates the scheduler
INIT:CONT OFF
Switches to single sweep mode.
INIT;*WAI
Starts a new data measurement and waits for the end of the
sweep.
INIT:SEQ:REFR
Refreshes the display for all channels.

```

SYSTem:SEQuencer <State>

Turns the Sequencer on and off. The Sequencer must be active before any other Sequencer commands (`INIT:SEQ. . .`) are executed, otherwise an error occurs.

A detailed programming example is provided in the "Operating Modes" chapter in the FSW User Manual.

Parameters:

<State>

ON | OFF | 0 | 1

ON | 1

The Sequencer is activated and a sequential measurement is started immediately.

OFF | 0

The Sequencer is deactivated. Any running sequential measurements are stopped. Further Sequencer commands (`INIT:SEQ. . .`) are not available.

*RST: 0

Example:

```

SYST:SEQ ON
Activates the Sequencer.
INIT:SEQ:MODE SING
Sets single Sequencer mode so each active measurement is
performed once.
INIT:SEQ:IMM
Starts the sequential measurements.
SYST:SEQ OFF

```

11.9 Retrieving results

The following commands are required to retrieve the results from a 3GPP FDD measurement in a remote environment.

When the channel type is required as a parameter by a remote command or provided as a result for a remote query, abbreviations or assignments to a numeric value are used as described in [Chapter 11.5.7, "Channel detection"](#), on page 206.

Specific commands:

- [Retrieving calculated measurement results](#)..... 247
- [Measurement results for TRACe<n>\[:DATA\]? TRACE<n>](#)..... 251
- [Retrieving trace results](#)..... 258
- [Exporting trace results](#)..... 267
- [Retrieving RF results](#)..... 269

11.9.1 Retrieving calculated measurement results

The following commands describe how to retrieve the calculated results from the CDA and "Time Alignment Error" measurements.

- [CALCulate<n>:MARKer<m>:FUNction:TAERror:RESult](#)..... 247
- [CALCulate<n>:MARKer<m>:FUNction:WCDPower:MS:RESult?](#)..... 248
- [CALCulate<n>:MARKer<m>:FUNction:WCDPower\[:BTS\]:RESult](#)..... 250

CALCulate<n>:MARKer<m>:FUNction:TAERror:RESult <ResultType>

Queries the result of a time alignment measurement for the selected frame (see [\[SENSe:\]CDPower:FRAMe\[:VALue\]](#) on page 223).

For details on the measurement see [Chapter 3.2, "Time alignment error measurements"](#), on page 34.

The results are provided as a comma-separated list of values for each carrier.

Suffix:

<n>	1..n Window
<m>	1..n Marker

Parameters:

<ResultType>	TAERror Returns the time offset between the two antenna signals in chips.
<Ant1State>	0 1 Synchronization state for antenna 1 0 No Sync 1 OK
<Ant2Delay>	numeric value Time delay for the carrier at antenna 2, relative to the reference carrier 0 Default unit: chips
<Ant2State>	0 1

Synchronization state for antenna 2

0

No Sync

1

OK

Example:

CALC:MARK:FUNC:TAER:RES? TAER

Result for multi-carrier measurement with 2 carriers:

-548.517578,0,-2017.237915,0,-3423.261230,0

where:

-548.517578: time delay of the antenna 2 signal for carrier 0, relative to the antenna 1 signal for carrier 0

0: sync state of antenna 2 for carrier 0

-2017.237915: time delay of the antenna 1 signal of carrier 1, relative to the antenna 1 signal for carrier 0

0: sync state of antenna 1 for carrier 1

-3423.261230: time delay of the antenna 2 signal of carrier 1, relative to the antenna 2 signal for carrier 0

0: sync state of antenna 2 for carrier 1

Example:

CALC:MARK:FUNC:TAER:RES? TAER

Result for single-carrier measurement:

-548.517578

This is the time delay of the antenna 2 signal relative to the antenna 1 signal.

Mode:

BTS application only

Manual operation:

See ["Time Alignment Error"](#) on page 35

CALCulate<n>:MARKer<m>:FUNction:WCDPower:MS:RESult? <Measurement>

This command queries the measured and calculated results of the 3GPP FDD UE code domain power measurement.

Suffix:

<n> [Window](#)

<m> [Marker](#)

Query parameters:

<Measurement> The parameter specifies the required evaluation method.

ACHannels

Number of active channels

CDPabsolute

code domain power absolute

CDPRelative

code domain power relative

CERRor

chip rate error

CHANnel	channel number
CMAppling	Channel branch
CSLot	channel slot number
EVMPeak	error vector magnitude peak
EVMRms	error vector magnitude RMS
FERRor	frequency error in Hz
IQIMbalance	I/Q imbalance
IQOFFset	I/Q offset
MACCuracy	composite EVM
MPIC	average power of the inactive codes for the selected slot
MTYPe	modulation type: BPSK-I: 0 BPSK-Q: 1 4PAM-I: 6 4PAM-Q: 7 NONE: 15
PCDerror	peak code domain error
PSYMBOL	Number of pilot bits
PTOTAL	total power
RHO	rho value for every slot
SRATE	symbol rate
TFRame	trigger to frame
TOFFset	timing offset

Example: `CALC:MARK:FUNC:WCDP:MS:RES? PTOT`

Usage: Query only

Mode: UE application only

Manual operation: See "[Code Domain Power](#)" on page 22

CALCulate<n>:MARKer<m>:FUNCTION:WCDPower[:BTS]:RESult <Measurement>

Queries the measured and calculated results of the 3GPP FDD BTS code domain power measurement.

Suffix:

<n> 1..n
[Window](#)

<m> 1..n
[Marker](#)

Parameters:

<Measurement> PTOTAL | FERRor | TFRame | TOFFset | MACCuracy | PCDerror | EVMRms | EVMPeak | CERRor | CSLot | SRATe | CHANnel | CDPabsolute | CDPRelative | IQOFFset | IQIMbalance | MTYPE | RHO | PSYMBOL | ACHannels | MPIC | RCDerror | ARCDerror | IOFFset | QOFFset

The parameter specifies the required evaluation method.

ACHannels

Number of active channels

ARCDerror

relative code domain error averaged over all channels with modulation type 64QAM

CDPabsolute

code domain power absolute

CDPRelative

code domain power relative

CERRor

chip rate error

CHANnel

channel number

CSLot

channel slot number

EVMPeak

error vector magnitude peak

EVMRms

error vector magnitude RMS

FERRor

frequency error in Hz

IOFFset

imaginary part of the I/Q offset

IQIMbalance

I/Q imbalance

IQOffset

I/Q offset

MACCuracy

composite EVM

MPIC

average power of inactive channels

MTYPe

modulation type:

2 – QPSK

4 – 16 QAM

5 – 64 QAM

15 – NONE

PCDerror

peak code domain error

PSYMBOL

number of pilot bits

PTOTAL

total power

QOFFSET

real part of the I/Q offset

RCDerror

relative code domain error

RHO

rho value for every slot

SRATe

symbol rate

TFRame

trigger to frame

TOFFset

timing offset

Example: `CALC:MARK:FUNC:WCDP:RES? PTOT`**Mode:** BTS application only**Manual operation:** See "[Code Domain Power](#)" on page 22

11.9.2 Measurement results for `TRACe<n>[:DATA]? TRACE<n>`

The evaluation method selected by the `LAY:ADD:WIND` command also affects the results of the trace data query (`TRACe<n>[:DATA]? TRACE<n>`, see [TRACe<n>\[:DATA\]](#) on page 259).

Details on the returned trace data depending on the evaluation method are provided here.

For details on the graphical results of these evaluation methods, see [Chapter 3, "Measurements and result display"](#), on page 16.

• Bitstream.....	252
• Channel table.....	253
• Code domain error power.....	254
• Code domain power.....	254
• Composite constellation.....	255
• Composite EVM (RMS).....	255
• EVM vs chip.....	255
• Frequency error vs slot.....	255
• Mag error vs chip.....	255
• Peak code domain error.....	255
• Phase discontinuity vs slot.....	256
• Phase error vs chip.....	256
• Power vs slot.....	256
• Power vs symbol.....	256
• Result summary.....	256
• Symbol constellation.....	257
• Symbol EVM.....	257
• Symbol magnitude error.....	258
• Symbol phase error.....	258

11.9.2.1 Bitstream

When the trace data for this evaluation is queried, the bit stream of one slot is transferred. Each symbol contains two consecutive bits in the case of a QPSK modulated slot and 4 consecutive bits in the case of a 16QAM modulated slot. One value is transferred per bit (range 0, 1). The number of symbols is not constant and may vary for each sweep. Individual symbols in the bit stream may be invalid depending on the channel type and the bit rate (symbols without power). The assigned invalid bits are marked by one of the digits "6", "7" or "9".

The values and number of the bits are as follows (without HS-DPCCH channels, see [\[SENSe:\]CDPower:HSDPamode](#) on page 162) :

Table 11-8: Bit values and numbers without HS-DPCCH channels

Unit	[]
Value range	{0, 1, 6, 9} 0 - Low state of a transmitted bit 1 - High state of a transmitted bit 6 - Bit of a symbol of a suppressed slot of a DPCH in Compressed Mode (DPCH-CPRSD) 9 - Bit of a suppressed symbol of a DPCH (e.g. TFCI off)
Bits per slot	$N_{\text{BitPerSymb}} = 2$
Number of symbols	$N_{\text{Symb}} = 10 * 2^{(8-\text{Code Class})}$
Number of bits	$N_{\text{Bit}} = N_{\text{Symb}} * N_{\text{BitPerSymb}}$
Format	Bit ₀₀ , Bit ₀₁ , Bit ₁₀ , Bit ₁₁ , Bit ₂₀ , Bit ₂₁ , ..., Bit _{N_{Symb} 0} , Bit _{N_{Symb} 1}

The values and number of the bits including HS-DPCCH channels (see [SENSe:]CDPower:HSDPamode on page 162) are as follows:

Table 11-9: Bit values and numbers including HS-DPCCH channels

Unit	[]
Value range	{0, 1, 6, 7, 8, 9} 0 - Low state of a transmitted bit 1 - High state of a transmitted bit 6 - Bit of a symbol of a suppressed slot of a DPCH in Compressed Mode (DPCH-CPRSD) 7 - Bit of a switched-off symbol of an HS-PDSCH channel 8 - Fill value for unused bits of a lower order modulation symbol in a frame containing higher order modulation 9 - Bit of a suppressed symbol of a DPCH (e.g. TFCI off)
Bits per symbol	$N_{\text{BitPerSymb}} = \{2, 4, 6\}$
Symbols per slot	$N_{\text{Symb_Slot}} = 10 \cdot 2^{(8-\text{Code Class})}$
Symbols per frame	$N_{\text{Symb_Frame}} = 15 \cdot N_{\text{Symb_Slot}} = 150 \cdot 2^{(8-\text{Code Class})}$
Number of bits	$N_{\text{Bit}} = N_{\text{Symb_Frame}} \cdot N_{\text{BitPerSymb_MAX}}$
Format (16QAM)	Bit ₀₀ , Bit ₀₁ , Bit ₀₂ , Bit ₀₃ , Bit ₁₀ , Bit ₁₁ , Bit ₁₂ , Bit ₁₃ , , Bit _{N_{Symb_Frame} 0} , Bit _{N_{Symb_Frame} 1} , Bit _{N_{Symb_Frame} 2} , Bit _{N_{Symb_Frame} 3}
Format (64QAM)	Bit ₀₀ , Bit ₀₁ , Bit ₀₂ , Bit ₀₃ , Bit ₀₄ , Bit ₀₅ , Bit ₁₀ , Bit ₁₁ , Bit ₁₂ , Bit ₁₃ , Bit ₁₄ , Bit ₁₅ , ... , Bit _{N_{Symb_Frame} 0} , Bit _{N_{Symb_Frame} 1} , Bit _{N_{Symb_Frame} 2} , Bit _{N_{Symb_Frame} 3} , Bit _{N_{Symb_Frame} 4} , Bit _{N_{Symb_Frame} 5}

11.9.2.2 Channel table

When the trace data for this evaluation is queried, 5 (7) values are transmitted for each channel (depending on the query parameter):

- the class
- the channel number
- the absolute level
- the relative level
- the timing offset
- the pilot length *)
- the active flag *)

*) for CTAB query parameter only

For details on these parameters see [TRAC:DATA? TRACE1](#) and [TRAC:DATA? CTAB](#).

Example:

The following example shows the results of a query for three channels with the following configuration:

Channel Pos.	Code class	Channel number	Abs. Level	Rel. level	Timing offset	Pilot Length	Active?
1	9	7	-40	-20	0	8	1
2	1	1	-40	-20	256 chips	2	1
3	7	255	-40	-20	2560 chips	6	1

TRAC:DATA? TRAC1 returns the following result:

9, 7, -40, -20, 0, 2, 1, -40, -20, 256, 7, 255, -40, -20, 2560

The channel order is the same as in the CDP diagram, i.e. it depends on their position in the code domain of spreading factor 512.

TRAC:DATA? CTAB returns the following result:

9, 7, -40, -20, 0, **8, 1, 1, 1**, -40, -20, 256, **2, 1, 7, 255**, -40, -20, 2560, **6, 1**

11.9.2.3 Code domain error power

When the trace data for this evaluation is queried, 4 values are transmitted for each channel with code class 9:

code class	Highest code class of a downlink signal, always set to 9 (CC9)
code number	Code number of the evaluated CC9 channel [0...511]
CDEP	Code domain error power value of the CC9 channel in [dB]
channel flag	Indicates whether the CC9 channel belongs to an assigned code channel: 0b00-0d0: CC9 is inactive. 0b01-0d1: CC9 channel belongs to an active code channel. 0b11-0d3: CC9 channel belongs to an active code channel; sent pilot symbols are incorrect

The channels are sorted by code number.

11.9.2.4 Code domain power

When the trace data for this evaluation is queried, 5 values are transmitted for each channel:

- the code class
- the channel number
- the absolute level
- the relative level
- the timing offset

For details on these parameters see [TRACe<n> \[:DATA\] ?](#) on page 260.

11.9.2.5 Composite constellation

When the trace data for this evaluation is queried, the real and the imaginary branches of the chip constellation at the selected slot are transferred:

<Re1>, <Im1>, <Re2>, <Im2>,, <Re2560>, <Im2560>

The values are normalized to the square root of the average power at the selected slot.

11.9.2.6 Composite EVM (RMS)

When the trace data for this evaluation is queried, 15 pairs of slots (slot number of CPICH) and level values are transferred:

<slot number>, <level value in %> (for 15 slots)

11.9.2.7 EVM vs chip

When the trace data for this evaluation is queried, a list of vector error values of all chips at the selected slot is returned (=2560 values). The values are calculated as the square root of the square difference between the received signal and the reference signal for each chip, normalized to the square root of the average power at the selected slot.

11.9.2.8 Frequency error vs slot

When the trace data for this evaluation is queried, 15 pairs of slot (slot number of CPICH) and values are transferred:

<slot number>, <value in Hz>

11.9.2.9 Mag error vs chip

When the trace data for this evaluation is queried, a list of magnitude error values of all chips at the selected slot is returned (=2560 values). The values are calculated as the magnitude difference between the received signal and the reference signal for each chip in %, and are normalized to the square root of the average power at the selected slot.

11.9.2.10 Peak code domain error

When the trace data for this evaluation is queried, 15 pairs of slots (slot number of CPICH) and level values are transferred:

<slot number>, <level value in dB> (for 15 slots)

11.9.2.11 Phase discontinuity vs slot

When the trace data for this evaluation is queried, 15 pairs of slot (slot number of CPICH) and values are transferred:

<slot number>, <value in deg>

11.9.2.12 Phase error vs chip

When the trace data for this evaluation is queried, a list of phase error values of all chips in the selected slot is returned (=2560 values). The values are calculated as the phase difference between the received signal and the reference signal for each chip in degrees, and are normalized to the square root of the average power at the selected slot.

11.9.2.13 Power vs slot

When the trace data for this evaluation is queried, 16 pairs of slots (slot number of CPICH) and level values are transferred:

<slot number>, <level value in dB> (for 16 slots)

11.9.2.14 Power vs symbol

When the trace data for this evaluation is queried, the power of each symbol at the selected slot is transferred. The values indicate the difference to the reference power in dB. The number of the symbols depends on the spreading factor of the selected channel:

$\text{NOFSymbols} = 10 * 2^{(8 - \text{CodeClass})}$

11.9.2.15 Result summary

When the trace data for this evaluation is queried, the results of the result summary are output in the following order:

<composite EVM [%]> ,

<peak CDE [dB]> ,

< carr freq error [Hz]> ,

< chip rate error [ppm]> ,

< total power [dB]> ,

< trg to frame [µs]> ,

< EVM peak channel [%]> ,

< EVM mean channel [%]> ,

< code class> ,

<channel number>,
 <power abs. channel [dB]>,
 <power rel. channel [dB], referenced to CPICH or total power>,
 <timing offset [chips]>,
 <number of pilot bits>
 <l/Q offset [%]>,
 <l/Q imbalance [%]>

11.9.2.16 Symbol constellation

When the trace data for this evaluation is queried, the real and the imaginary branches are transferred:

<Re₀>, <Im₀>, <Re₁>, <Im₁>, ..., <Re_n>, <Im_n>

The number of level values depends on the spreading factor:

Spreading factor	Number of level values
512	5
256	10
128	20
64	40
32	80
16	160
8	320
4	640

11.9.2.17 Symbol EVM

When the trace data for this evaluation is queried, the real and the imaginary branches are transferred:

<Re₀>, <Im₀>, <Re₁>, <Im₁>, ..., <Re_n>, <Im_n>

The number of level values depends on the spreading factor:

Spreading factor	Number of level values
512	5
256	10
128	20
64	40

Spreading factor	Number of level values
32	80
16	160
8	320
4	640

11.9.2.18 Symbol magnitude error

When the trace data for this evaluation is queried, the magnitude error in % of each symbol at the selected slot is transferred. The number of the symbols depends on the spreading factor of the selected channel:

$$\text{NOFSymbols} = 10 * 2^{(8 - \text{CodeClass})}$$

11.9.2.19 Symbol phase error

When the trace data for this evaluation is queried, the phase error in degrees of each symbol at the selected slot is transferred. The number of the symbols depends on the spreading factor of the selected channel:

$$\text{NOFSymbols} = 10 * 2^{(8 - \text{CodeClass})}$$

11.9.3 Retrieving trace results

The following commands describe how to retrieve the trace data from the CDA and "Time Alignment Error" measurements. Note that for these measurements, only 1 trace per window can be configured.

- `FORMat[:DATA]`
- `TRACe<n>[:DATA]` on page 259
- `TRACe<n>[:DATA]? TRACE1`
- `TRACe<n>[:DATA]? ABITstream`
- `TRACe<n>[:DATA]? ATRace1`
- `TRACe<n>[:DATA]? CTABLE`
- `TRACe<n>[:DATA]? CWCDp`
- `TRACe<n>[:DATA]? FINall`
- `TRACe<n>[:DATA]? LIST`
- `TRACe<n>[:DATA]? PWCDp`
- `TRACe<n>[:DATA]? TPVSlot`

FORMat[:DATA] <Format>[, <BitLength>]

Selects the data format that is used for transmission of trace data from the FSW to the controlling computer.

Note that the command has no effect for data that you send to the FSW. The FSW automatically recognizes the data it receives, regardless of the format.

Parameters:

<Format>

ASCII

ASCII format, separated by commas.

This format is almost always suitable, regardless of the actual data format. However, the data is not as compact as other formats can be.

REAL

Floating-point numbers (according to IEEE 754) in the "definite length block format".

In the Spectrum application, the format setting `REAL` is used for the binary transmission of trace data.

<BitLength>

Length in bits for floating-point results

16

16-bit floating-point numbers.

Compared to `REAL, 32` format, half as many numbers are returned.

32

32-bit floating-point numbers

For I/Q data, 8 bytes per sample are returned for this format setting.

64

64-bit floating-point numbers

Compared to `REAL, 32` format, twice as many numbers are returned.

Example:

```
FORM REAL, 32
```

TRACe<n>[:DATA] <ResultType>

Reads trace data from the FSW.

For details on reading trace data for other than code domain measurements refer to the `TRACe:DATA` command in the base unit description.

Suffix:

<n>

[Window](#)

Parameters:

<ResultType>

ATRace1 | ATRace2 | ATRace3 | ATRace4 | FINal1 | TRACe1 | TRACe2 | TRACe3 | TRACe4 | ABITstream | ABITstream1 | ABITstream2 | ABITstream3 | ABITstream4 | PWCDp | CWCDp | CTABLE | TPVSlot | LIST

The individual results are described in [Chapter 11.9.2, "Measurement results for TRACe<n>\[:DATA\]? TRACE<n>"](#), on page 251.

TRACe<n>[:DATA]? TRACE1

This command returns the trace data. Depending on the evaluation, the trace data format varies.

The channels are output in a comma-separated list in ascending order sorted by code number, i.e. in the same sequence they are displayed on screen.

For details see [Chapter 11.9.2, "Measurement results for TRACe<n>\[:DATA\]? TRACE<n>"](#), on page 251.

Suffix:

<n> [Window](#)

Return values:

<CodeClass>	2 ... 9 Code class of the channel
<ChannelNo>	0 ... 511 Code number of the channel
<AbsLevel>	dBm Absolute level of the code channel at the selected channel slot.
<RelLevel>	% Relative level of the code channel at the selected channel slot referenced to CPICH or total power.
<TimingOffset>	0 ... 38400 [chips] Timing offset of the code channel to the CPICH frame start. The value is measured in chips. The step width is 256 chips in the case of code class 2 to 8, and 512 chips in the case of code class 9.

Example:

```
TRAC2:DATA? TRACE1
```

Returns the trace data from trace 1 in window 2.

Usage:

Query only

Manual operation:

See ["Code Domain Error Power"](#) on page 23
 See ["Composite Constellation"](#) on page 23
 See ["Composite EVM"](#) on page 24
 See ["EVM vs Chip"](#) on page 25
 See ["Magnitude Error vs Chip"](#) on page 26
 See ["Peak Code Domain Error"](#) on page 28
 See ["Phase Discontinuity vs Slot"](#) on page 28
 See ["Phase Error vs Chip"](#) on page 29
 See ["Power vs Symbol"](#) on page 31
 See ["Result Summary"](#) on page 31
 See ["Symbol Constellation"](#) on page 32
 See ["Symbol EVM"](#) on page 32
 See ["Symbol Magnitude Error"](#) on page 33
 See ["Symbol Phase Error"](#) on page 33

TRACe<n>[:DATA]? ABITstream

This command returns the bit streams of all 15 slots one after the other. The output format may be REAL, UINT or ASCII. The number of bits of a 16QAM-modulated channel is twice that of a QPSK-modulated channel, the number of bits of a 64QAM-modulated channel is three times that of a QPSK-modulated channel.

This query is only available if the evaluation for the corresponding window is set to "Bitstream" using the `LAY:ADD:WIND "XTIM:CDP:BSTream"` command (see [LAYout:ADD\[:WINDOW\]?](#) on page 235).

The output format is identical to that of the `TRAC:DATA? TRAC` command for an activated "Bitstream" evaluation (see [Chapter 11.9.2, "Measurement results for TRACe<n>\[:DATA\]? TRACE<n>"](#), on page 251). The only difference is the number of symbols which are evaluated. The `ABITstream` parameter evaluates all symbols of one entire frame (vs. only one slot for `TRAC:DATA? TRAC`).

The values 7 and 8 are only used in case of a varying modulation type of an HS-PDSCH channel. In this case the number of bits per symbol (`NBitPerSymb`) varies, as well. However, the length of the transmitted bit vector (`NBit`) depends only on the maximum number of bits per symbol in that frame. Thus, if the modulation type changes throughout the frame this will not influence the number of bits being transmitted (see examples below).

Suffix:

<n> [Window](#)

Example:

```
LAY:REPL 2, "XTIM:CDP:BSTream"
```

Sets the evaluation for window 2 to bit stream.

```
TRAC2:DATA? ABITstream
```

Returns the bit streams of all 15 slots in window 2, one after the other.

Usage:

Query only

Manual operation: See ["Bitstream"](#) on page 19

Examples for bits 7 and 8 for changing modulation types**Example 1:**

Some slots of the frame are 64QAM modulated, other are 16QAM and QPSK modulated and some are switched OFF (NONE). If one or more slots of the frame are 64QAM modulated, six bits per symbol are transmitted and if the highest modulation order is 16QAM, four bits per symbol are transmitted. In any slot of the frame with lower order modulation, the first two or four of the four or six bits are marked by the number 8 and the last bits represent the transmitted symbol. If no power is transmitted in a slot, four or six entries per symbol of value 7 are transmitted.

Example 2:

Some slots of the frame are QPSK modulated and some are switched OFF. If one or more slots of the frame are QPSK modulated and no slot is 16QAM modulated, 2 bits per symbol are transmitted. If no power is transmitted in a slot, 2 entries per symbol of value 7 are transmitted.

Example 3:

Some slots of a DPCH are suppressed because of compressed mode transmission. The bits of the suppressed slots are marked by the digit '6'. In this case, always 2 bits per symbol are transmitted.

TRACe<n>[:DATA]? ATRace1

This command returns a list of absolute "Frequency Error vs Slot" values for all 16 slots (based on CPICH slots). In contrast to the `TRACE1` parameter return value, absolute values are returned.

Suffix:

<n> [Window](#)

Return values:

<SlotNumber> Slot number

<FreqError> Absolute frequency error

Default unit: Hz

Example:

`TRAC2:DATA? ATR`

Returns a list of absolute frequency errors for all slots in window 2.

Usage: Query only

Mode: BTS application only

Manual operation: See "[Frequency Error vs Slot](#)" on page 26

TRACe<n>[:DATA]? CTABLE

This command returns the pilot length and the channel state (active, inactive) in addition to the values returned for `TRACE<t>`.

This command is only available for "Code Domain Power" or "Channel Table" evaluations (see [Chapter 3.1.2, "Evaluation methods for code domain analysis"](#), on page 19).

Suffix:

<n> [Window](#)

Return values:

<CodeClass> **2 ... 9**
Code class of the channel

<ChannelNo> **0 ... 511**
Code number of the channel

<AbsLevel> **dBm**
Absolute level of the code channel at the selected channel slot.

<RelLevel> **%**
Relative level of the code channel at the selected channel slot referenced to CPICH or total power.

<TimingOffset>	0 ... 38400 [chips] Timing offset of the code channel to the CPICH frame start. The value is measured in chips. The step width is 256 chips in the case of code class 2 to 8, and 512 chips in the case of code class 9.
<PilotLength>	The length of the pilot symbols. According to the 3GPP standard, the pilot length range depends on the code class. Range: 0,2,4,8,16 Default unit: symbols
<ActiveFlag>	0 1 Flag to indicate whether a channel is active (1) or not (0)
Example:	TRAC:DATA? CTABle Returns a list of channel information, including the pilot length and channel state.
Usage:	Query only
Manual operation:	See " Channel Table " on page 20 See " Code Domain Power " on page 22

TRACe<n>[:DATA]? CWCDp

This command returns additional results to the values returned for TRACE<t>.

The result is a comma-separated list with 10 values for each channel; the channels are output in ascending order sorted by code number, i.e. in the same sequence they are displayed on screen.

This command is only available for "Code Domain Power" or "Channel Table" evaluations (see [Chapter 3.1.2, "Evaluation methods for code domain analysis"](#), on page 19).

Suffix:

<n> [Window](#)

Return values:

<CodeClass>	2 ... 9 Code class of the channel
<ChannelNo>	0 ... 511 Code number of the channel
<AbsLevel>	dBm Absolute level of the code channel at the selected channel slot.
<RelLevel>	% Relative level of the code channel at the selected channel slot referenced to CPICH or total power.

<TimingOffset>	0 ... 38400 [chips] Timing offset of the code channel to the CPICH frame start. The value is measured in chips. The step width is 256 chips in the case of code class 2 to 8, and 512 chips in the case of code class 9.
<PilotLength>	The length of the pilot symbols. According to the 3GPP standard, the pilot length range depends on the code class. Range: 0,2,4,8,16 Default unit: symbols
<ActiveFlag>	0 1 Flag to indicate whether a channel is active (1) or not (0)
<ChannelType>	Channel type. For details see Table 11-4 . Range: 0 ... 16
<ModType>	Modulation type of the code channel at the selected channel slot 2 QPSK 4 16 QAM 15 NONE There is no power in the selected channel slot (slot is switched OFF). Range: 2,4,15
<Reserved>	for future use
Example:	TRAC:DATA? CWCDp Returns a list of channel information for each channel in ascending order.
Usage:	Query only
Manual operation:	See " Channel Table " on page 20 See " Code Domain Power " on page 22

TRACe<n>[:DATA]? FINal1

This command returns the peak list. For each peak the following results are given:

Suffix:

<n> [Window](#)

Return values:

<Freq> Peak frequency

<Level> Peak level

<DeltaLevel> Delta between current peak level and next higher peak level

Example:	TRAC2:DATA? FINa11 Returns a list of peak values.
Usage:	Query only
Mode:	BTS application only

TRACe<n>[:DATA]? LIST

This command returns the peak list of the spectrum emission mask measurement list evaluation.

An array of values is returned for each range of the limit line:

<array of range 1>, <array of range 2>,, <array of range n>,

where each array consists of the following values:

<No>, <Start>, <Stop>, <RBW>, <Freq>, <Levelabs>, <Levelrel>, <Delta>, <Limit-check>, <Unused1>, <Unused2>

Suffix:

<n> [Window](#)

Parameters:

<No>	Number of the limit line range
<Start>	Start frequency of the limit line range Default unit: Hz
<Stop>	Stop frequency of the limit line range Default unit: Hz
<RBW>	Resolution bandwidth of the limit line range Default unit: Hz
<Freq>	Frequency of the peak power within the range Default unit: Hz
<Levelabs>	Absolute power of the peak within the range Default unit: dBm
<Levelrel>	Relative power of the peak within the range related to channel power Default unit: dB
<Delta>	Power difference to margin power Default unit: dB
<Limitcheck>	0 1 Indicates whether the power is below [0] or above [1] the limit line
<Unused1>	for future use
<Unused2>	for future use

Example: TRAC2:DATA? LIST
Returns a list of SEM results for all slots in window 2.

Usage: Query only

TRACe<n>[:DATA]? PWCDp

This command returns the pilot length in addition to the values returned for "TRACE<t>".

This command is only available for "Code Domain Power" or "Channel Table" evaluations (see [Chapter 3.1.2, "Evaluation methods for code domain analysis"](#), on page 19).

Suffix:

<n> [Window](#)

Return values:

<CodeClass>	2 ... 9 Code class of the channel
<ChannelNo>	0 ... 511 Code number of the channel
<AbsLevel>	dBm Absolute level of the code channel at the selected channel slot.
<RelLevel>	% Relative level of the code channel at the selected channel slot referenced to CPICH or total power.
<TimingOffset>	0 ... 38400 [chips] Timing offset of the code channel to the CPICH frame start. The value is measured in chips. The step width is 256 chips in the case of code class 2 to 8, and 512 chips in the case of code class 9.
<PilotLength>	0,2,4,8,16 The length of the pilot symbols. According to the 3GPP standard, the pilot length range depends on the code class. Default unit: symbols

Example: TRAC:DATA? PWCDp
Returns a list of channel information, including the pilot length.

Usage: Query only

Mode: BTS application only

Manual operation: See ["Channel Table"](#) on page 20
See ["Code Domain Power"](#) on page 22

TRACe<n>[:DATA]? TPVSlot

This command returns a comma-separated list of absolute "Power vs Slot" results for all 16 slots. In contrast to the `TRACe<t>` parameter result, absolute values are returned.

Suffix:

<n> [Window](#)

Return values:

<SlotNumber> **0...15**
CPICH slot number

<Level> **dBm**
Slot level value

Example:

```
CALC2:FEED 'XTIM:CDP:PVSlot:ABSolute'
```

Sets the evaluation for window 2 to POWER VS SLOT.

```
TRAC2:DATA? TPVSlot
```

Returns a list of absolute frequency errors for all slots in window 2.

Usage: Query only

Manual operation: See "Power vs Slot" on page 30

11.9.4 Exporting trace results

RF measurement trace results can be exported to a file.

For more commands concerning data and results storage see the FSW User Manual.

MMEMory:STORe<n>:FINal	267
MMEMory:STORe<n>:TRACe	268
FORMat:DEXPort:DSEParator	268
FORMat:DEXPort:HEADer	269
FORMat:DEXPort:TRACes	269

MMEMory:STORe<n>:FINal <FileName>

Exports the marker peak list to a file.

The file format is *.dat.

Suffix:

<n> 1..n
[Window](#)

Parameters:

<FileName> String containing the path and name of the target file.

<TraceNo> Always 1

<Frequency> Frequency of the peak in Hz

<Level> Absolute level of the peak in dBm

<DeltaLevel> Distance to the limit line in dB

Example: `MMEM:STOR:FIN 'C:\test'`
Saves the current marker peak list in the file `test.dat`.

MMEMory:STORe<n>:TRACe <Trace>, <FileName>

Exports trace data from the specified window to an ASCII file.

Trace export is only available for RF measurements.

For details on the file format, see "Reference: ASCII File Export Format" in the FSW base unit user manual.

Secure User Mode

In secure user mode, settings that are stored on the instrument are stored to volatile memory, which is restricted to 256 MB. Thus, a "memory limit reached" error can occur although the hard disk indicates that storage space is still available.

To store data permanently, select an external storage location such as a USB memory device.

For details, see "Protecting Data Using the Secure User Mode" in the "Data Management" section of the FSW base unit user manual.

Suffix:

<n> [Window](#)

Parameters:

<Trace> Number of the trace to be stored

<FileName> String containing the path and name of the target file.

Example: `MMEM:STOR1:TRAC 1, 'C:\TEST.ASC'`
Stores trace 1 from window 1 in the file `TEST.ASC`.

FORMat:DEXPort:DSEParator <Separator>

Selects the decimal separator for data exported in ASCII format.

Parameters:

<Separator> `POINT` | `COMMa`

COMMa

Uses a comma as decimal separator, e.g. `4,05`.

POINT

Uses a point as decimal separator, e.g. `4.05`.

***RST:** *RST has no effect on the decimal separator.
Default is `POINT`.

Example: `FORM:DEXP:DSEP POIN`
Sets the decimal point as separator.

Manual operation: See "[Decimal Separator](#)" on page 123

FORMat:DEXPort:HEADer <State>

If enabled, additional instrument and measurement settings are included in the header of the export file for result data. If disabled, only the pure result data from the selected traces and tables is exported.

Parameters:

<State> ON | OFF | 0 | 1
*RST: 1

Manual operation: See ["Include Instrument & Measurement Settings"](#) on page 123

FORMat:DEXPort:TRACes <Selection>

Selects the data to be included in a data export file (see [MMEMory:STORe<n>:TRACe](#) on page 268).

Parameters:

<Selection> SINGle | ALL

SINGle

Only a single trace is selected for export, namely the one specified by the [MMEMory:STORe<n>:TRACe](#) command.

ALL

Selects all active traces and result tables (e.g. "Result Summary", marker peak list etc.) in the current application for export to an ASCII file.

The <trace> parameter for the [MMEMory:STORe<n>:TRACe](#) command is ignored.

*RST: SINGle

Manual operation: See ["Export all Traces and all Table Results"](#) on page 123

11.9.5 Retrieving RF results

The following commands are required to retrieve the results of the 3GPP FDD RF measurements.

See also:

- [MMEMory:STORe<n>:FINAl](#) on page 267
- [CALCulate<n>:MARKer<m>:Y?](#) on page 276

CALCulate<n>:LIMit:FAIL?	269
CALCulate<n>:MARKer<m>:FUNCTion:POWer<sb>:RESult?	270
CALCulate<n>:STATistics:RESult<res>?	272

CALCulate<n>:LIMit:FAIL?

Queries the result of a limit check in the specified window.

Note that for SEM measurements, the limit line suffix is irrelevant, as only one specific SEM limit line is checked for the currently relevant power class.

To get a valid result, you have to perform a complete measurement with synchronization to the end of the measurement before reading out the result. This is only possible for single measurement mode.

See also [INITiate<n>:CONTInuous](#) on page 243.

Suffix:

<n> [Window](#)

 [Limit line](#)

Return values:

<Result> **0**
 PASS
 1
 FAIL

Example:

```
INIT;*WAI
Starts a new sweep and waits for its end.
CALC2:LIM3:FAIL?
Queries the result of the check for limit line 3 in window 2.
```

Usage: Query only

Manual operation: See ["RF Combi"](#) on page 37
 See ["Spectrum Emission Mask"](#) on page 38

CALCulate<n>:MARKer<m>:FUNCtion:POWER<sb>:RESult? <Measurement>

Queries the results of power measurements.

To get a valid result, you have to perform a complete measurement with synchronization to the end of the measurement before reading out the result. This is only possible for single measurement mode.

See also [INITiate<n>:CONTInuous](#) on page 243.

Suffix:

<n> irrelevant

<m> irrelevant

<sb> Sub block in a Multi-standard radio measurement;
 MSR ACLR: 1 to 8
 Multi-SEM: 1 to 8
 for all other measurements: irrelevant

Parameters:

<Measurement>

ACPower | MCACpower

ACLR measurements (also known as adjacent channel power or multicarrier adjacent channel measurements).

Returns the power for every active transmission and adjacent channel. The order is:

- power of the transmission channels
- power of adjacent channel (lower, upper)
- power of alternate channels (lower, upper)

MSR ACLR results:

For MSR ACLR measurements, the order of the returned results is slightly different:

- power of the transmission channels
- total power of the transmission channels for each sub block
- power of adjacent channels (lower, upper)
- power of alternate channels (lower, upper)
- power of gap channels (lower1, upper1, lower2, upper2)

The unit of the return values depends on the scaling of the y-axis:

- logarithmic scaling returns the power in the current unit
- linear scaling returns the power in W

GACLR

For MSR ACLR measurements only: returns a list of ACLR values for each gap channel (lower1, upper1, lower2, upper2)

MACM

For MSR ACLR measurements only: returns a list of CAACLR values for each gap channel (lower1, upper1, lower2, upper2)

CN

Carrier-to-noise measurements.

Returns the C/N ratio in dB.

CNO

Carrier-to-noise measurements.

Returns the C/N ratio referenced to a 1 Hz bandwidth in dBm/Hz.

CPOWER

Channel power measurements.

Returns the channel power. The unit of the return values depends on the scaling of the y-axis:

- logarithmic scaling returns the power in the current unit
- linear scaling returns the power in W

For SEM measurements, the return value is the channel power of the reference range (in the specified sub block).

PPOWer

Peak power measurements.

Returns the peak power. The unit of the return values depends on the scaling of the y-axis:

- logarithmic scaling returns the power in the current unit
- linear scaling returns the power in W

For SEM measurements, the return value is the peak power of the reference range (in the specified sub block).

OBANdwidth | OBWidth

Occupied bandwidth.

Returns the occupied bandwidth in Hz.

Manual operation: See ["Channel Power ACLR"](#) on page 36
 See ["Occupied Bandwidth"](#) on page 36
 See ["Power"](#) on page 36
 See ["RF Combi"](#) on page 37
 See ["Spectrum Emission Mask"](#) on page 38
 See ["CCDF"](#) on page 39

CALCulate<n>:STATistics:RESult<res>? <ResultType>

Queries the results of a measurement for a specific trace.

Suffix:

<n> [Window](#)

<res> [Trace](#)

Query parameters:

<ResultType>

MEAN

Average (=RMS) power in dBm measured during the measurement time.

PEAK

Peak power in dBm measured during the measurement time.

CFACTOR

Determined crest factor (= ratio of peak power to average power) in dB.

ALL

Results of all three measurements mentioned before, separated by commas: <mean power>,<peak power>,<crest factor>

Example:

`CALC:STAT:RES2? ALL`

Reads out the three measurement results of trace 2. Example of answer string: 5.56,19.25,13.69 i.e. mean power: 5.56 dBm, peak power 19.25 dBm, crest factor 13.69 dB

Usage:

Query only

Manual operation: See ["CCDF"](#) on page 39

11.10 Analysis

The following commands define general result analysis settings concerning the traces and markers.

- [Traces](#)..... 273
- [Markers](#)..... 274

11.10.1 Traces

The trace settings determine how the measured data is analyzed and displayed on the screen. In 3GPP FDD applications, only one trace per window can be configured for Code Domain Analysis.

- [DISPlay\[:WINDow<n>\]\[:SUBWindow<w>\]:TRACe<t>:MODE](#).....273
- [DISPlay\[:WINDow<n>\]\[:SUBWindow<w>\]:TRACe<t>\[:STATe\]](#)..... 274

DISPlay[:WINDow<n>][:SUBWindow<w>]:TRACe<t>:MODE <Mode>

Selects the trace mode. If necessary, the selected trace is also activated.

For max hold, min hold or average trace mode, you can set the number of single measurements with [\[SENSe:\]SWEep:COUNT](#). Note that synchronization to the end of the measurement is possible only in single sweep mode.

Suffix:

<n>	Window
<w>	subwindow Not supported by all applications
<t>	Trace

Parameters:

<Mode>

WRITE

(default:) Overwrite mode: the trace is overwritten by each sweep.

AVERage

The average is formed over several sweeps. The "Sweep/Average Count" determines the number of averaging procedures.

MAXHold

The maximum value is determined over several sweeps and displayed. The FSW saves the sweep result in the trace memory only if the new value is greater than the previous one.

MINHold

The minimum value is determined from several measurements and displayed. The FSW saves the sweep result in the trace memory only if the new value is lower than the previous one.

VIEW

The current contents of the trace memory are frozen and displayed.

BLANK

Hides the selected trace.

*RST: Trace 1: WRITe, Trace 2-6: BLANK

Example:

```
INIT:CONT OFF
```

Switching to single sweep mode.

```
SWE:COUN 16
```

Sets the number of measurements to 16.

```
DISP:TRAC3:MODE WRIT
```

Selects clear/write mode for trace 3.

```
INIT;*WAI
```

Starts the measurement and waits for the end of the measurement.

Manual operation: See "[Trace Mode](#)" on page 121

DISPlay[:WINDow<n>][:SUBWindow<w>]:TRACe<t>[:STATe] <State>

Turns a trace on and off.

The measurement continues in the background.

Suffix:

<n> [Window](#)

<w> subwindow
Not supported by all applications

<t> [Trace](#)

Parameters:

<State> ON | OFF | 0 | 1

OFF | 0

Switches the function off

ON | 1

Switches the function on

Example:

```
DISP:TRAC3 ON
```

11.10.2 Markers

Markers help you analyze your measurement results by determining particular values in the diagram. In 3GPP FDD applications, only 4 markers per window can be configured for Code Domain Analysis.

- [Individual marker settings](#)..... 275
- [General marker settings](#).....278
- [Positioning the marker](#)..... 279

11.10.2.1 Individual marker settings

CALCulate<n>:MARKer<m>[:STATe].....	275
CALCulate<n>:MARKer<m>:X.....	275
CALCulate<n>:MARKer<m>:Y?.....	276
CALCulate<n>:MARKer<m>:AOFF.....	276
CALCulate<n>:DELTamarker<m>[:STATe].....	276
CALCulate<n>:DELTamarker<m>:AOFF.....	277
CALCulate<n>:DELTamarker<m>:X.....	277
CALCulate<n>:DELTamarker<m>:X:RELative?.....	277
CALCulate<n>:DELTamarker<m>:Y?.....	278

CALCulate<n>:MARKer<m>[:STATe] <State>

Turns markers on and off. If the corresponding marker number is currently active as a delta marker, it is turned into a normal marker.

Suffix:

<n> [Window](#)

<m> [Marker](#)

Parameters:

<State> ON | OFF | 0 | 1

OFF | 0

Switches the function off

ON | 1

Switches the function on

Example:

CALC:MARK3 ON
Switches on marker 3.

Manual operation: See ["Marker State"](#) on page 124
See ["Marker Type"](#) on page 125

CALCulate<n>:MARKer<m>:X <Position>

Moves a marker to a specific coordinate on the x-axis.

If necessary, the command activates the marker.

If the marker has been used as a delta marker, the command turns it into a normal marker.

Suffix:

<n> [Window](#)

<m> [Marker](#)

Parameters:

<Position> Numeric value that defines the marker position on the x-axis.
The unit depends on the result display.

Range: The range depends on the current x-axis range.

Default unit: Hz

Example: `CALC:MARK2:X 1.7MHz`
Positions marker 2 to frequency 1.7 MHz.

Manual operation: See ["Marker Table"](#) on page 27
See ["Marker Peak List"](#) on page 41
See ["X-value"](#) on page 125

CALCulate<n>:MARKer<m>:Y?

Queries the result at the position of the specified marker.

Suffix:

<n> 1..n

<m> 1..n

Return values:

<Result> Default unit: DBM

Usage: Query only

Manual operation: See ["Marker Table"](#) on page 27
See ["CCDF"](#) on page 39
See ["Marker Peak List"](#) on page 41

CALCulate<n>:MARKer<m>:AOFF

Turns off all markers.

Suffix:

<n> [Window](#)

<m> [Marker](#)

Example: `CALC:MARK:AOFF`
Switches off all markers.

Manual operation: See ["All Markers Off"](#) on page 125

CALCulate<n>:DELTamarker<m>[:STATe] <State>

Turns delta markers on and off.

If necessary, the command activates the delta marker first.

No suffix at DELTmarker turns on delta marker 1.

Suffix:

<n> [Window](#)

<m> [Marker](#)

Parameters:

<State> ON | OFF | 0 | 1

OFF | 0

Switches the function off

ON | 1

Switches the function on

Example: `CALC:DELT2 ON`
Turns on delta marker 2.

Manual operation: See "[Marker State](#)" on page 124
See "[Marker Type](#)" on page 125

CALCulate<n>:DELTamarker<m>:AOFFTurns off *all* delta markers.**Suffix:**<n> [Window](#)

<m> irrelevant

Example: `CALC:DELT:AOFF`
Turns off all delta markers.

CALCulate<n>:DELTamarker<m>:X <Position>

Moves a delta marker to a particular coordinate on the x-axis.

If necessary, the command activates the delta marker and positions a reference marker to the peak power.

Suffix:<n> [Window](#)<m> [Marker](#)**Parameters:**

<Position> Numeric value that defines the marker position on the x-axis.
Range: The value range and unit depend on the measurement and scale of the x-axis.

Example: `CALC:DELT:X?`
Outputs the absolute x-value of delta marker 1.

Manual operation: See "[X-value](#)" on page 125

CALCulate<n>:DELTamarker<m>:X:RELative?

Queries the relative position of a delta marker on the x-axis.

If necessary, the command activates the delta marker first.

Suffix:<n> [Window](#)<m> [Marker](#)**Return values:**

<Position> Position of the delta marker in relation to the reference marker.

Example: `CALC:DELT3:X:REL?`
Outputs the frequency of delta marker 3 relative to marker 1 or relative to the reference position.

Usage: Query only

CALCulate<n>:DELTaMarker<m>:Y?

Queries the result at the position of the specified delta marker.

Suffix:

<n> 1..n

<m> 1..n

Return values:

<Result> Result at the position of the delta marker.
The unit is variable and depends on the one you have currently set.

Default unit: DBM

Usage: Query only

11.10.2.2 General marker settings

[DISPlay\[:WINDow<n>\]:MTABLE](#)..... 278

DISPlay[:WINDow<n>]:MTABLE <DisplayMode>

Turns the marker table on and off.

Suffix:

<n> irrelevant

Parameters:

<DisplayMode> **ON | 1**
Turns on the marker table.

OFF | 0
Turns off the marker table.

AUTO
Turns on the marker table if 3 or more markers are active.

*RST: AUTO

Example: `DISP:MTAB ON`
Activates the marker table.

Manual operation: See "[Marker Table Display](#)" on page 126

11.10.2.3 Positioning the marker

This chapter contains remote commands necessary to position the marker on a trace.

- [Positioning normal markers](#).....279
- [Positioning delta markers](#).....281

Positioning normal markers

The following commands position markers on the trace.

CALCulate<n>:MARKer<m>:FUNction:CPICh	279
CALCulate<n>:MARKer<m>:FUNction:PCCPch	279
CALCulate<n>:MARKer<m>:MAXimum:LEFT	280
CALCulate<n>:MARKer<m>:MAXimum:NEXT	280
CALCulate<n>:MARKer<m>:MAXimum[:PEAK]	280
CALCulate<n>:MARKer<m>:MAXimum:RIGHT	280
CALCulate<n>:MARKer<m>:MINimum:LEFT	280
CALCulate<n>:MARKer<m>:MINimum:NEXT	281
CALCulate<n>:MARKer<m>:MINimum[:PEAK]	281
CALCulate<n>:MARKer<m>:MINimum:RIGHT	281

CALCulate<n>:MARKer<m>:FUNction:CPICh

Sets the marker to channel 0.

Is only available in "Code Domain Power" and "Code Domain Error Power" evaluations.

Suffix:

<n> 1..n
 [Window](#)

<m> 1..n
 [Marker](#)

Example: CALC:MARK:FUNC:CPIC

Manual operation: See "[Marker To CPICH](#)" on page 129

CALCulate<n>:MARKer<m>:FUNction:PCCPch

Sets the marker to the position of the PCCPCH.

Is only available in code domain power and code domain error power evaluations.

Suffix:

<n> 1..n
 [Window](#)

<m> 1..n
 [Marker](#)

Example: CALC:MARK:FUNC:PCCP

Manual operation: See "[Marker To PCCPCH](#)" on page 129

CALCulate<n>:MARKer<m>:MAXimum:LEFT

Moves a marker to the next positive peak.

The search includes only measurement values to the left of the current marker position.

Suffix:

<n> [Window](#)

<m> [Marker](#)

Manual operation: See ["Search Next Peak"](#) on page 128

CALCulate<n>:MARKer<m>:MAXimum:NEXT

Moves a marker to the next positive peak.

Suffix:

<n> [Window](#)

<m> [Marker](#)

Manual operation: See ["Search Next Peak"](#) on page 128

CALCulate<n>:MARKer<m>:MAXimum[:PEAK]

Moves a marker to the highest level.

If the marker is not yet active, the command first activates the marker.

Suffix:

<n> [Window](#)

<m> [Marker](#)

Manual operation: See ["Peak Search"](#) on page 128

CALCulate<n>:MARKer<m>:MAXimum:RIGHT

Moves a marker to the next positive peak.

The search includes only measurement values to the right of the current marker position.

Suffix:

<n> [Window](#)

<m> [Marker](#)

Manual operation: See ["Search Next Peak"](#) on page 128

CALCulate<n>:MARKer<m>:MINimum:LEFT

Moves a marker to the next minimum peak value.

The search includes only measurement values to the right of the current marker position.

Suffix:

<n> [Window](#)

<m> [Marker](#)

Manual operation: See ["Search Next Minimum"](#) on page 128

CALCulate<n>:MARKer<m>:MINimum:NEXT

Moves a marker to the next minimum peak value.

Suffix:

<n> [Window](#)

<m> [Marker](#)

Manual operation: See ["Search Next Minimum"](#) on page 128

CALCulate<n>:MARKer<m>:MINimum[:PEAK]

Moves a marker to the minimum level.

If the marker is not yet active, the command first activates the marker.

Suffix:

<n> [Window](#)

<m> [Marker](#)

Manual operation: See ["Search Minimum"](#) on page 128

CALCulate<n>:MARKer<m>:MINimum:RIGHT

Moves a marker to the next minimum peak value.

The search includes only measurement values to the right of the current marker position.

Suffix:

<n> [Window](#)

<m> [Marker](#)

Manual operation: See ["Search Next Minimum"](#) on page 128

Positioning delta markers

The following commands position delta markers on the trace.

CALCulate<n>:DELTamarker<m>:FUNction:CPICH.....	282
CALCulate<n>:DELTamarker<m>:FUNction:PCCPch.....	282
CALCulate<n>:DELTamarker<m>:MAXimum:LEFT.....	282
CALCulate<n>:DELTamarker<m>:MAXimum:NEXT.....	282

CALCulate<n>:DELTamarker<m>:MAXimum[:PEAK].....	283
CALCulate<n>:DELTamarker<m>:MAXimum:RIGHT.....	283
CALCulate<n>:DELTamarker<m>:MINimum:LEFT.....	283
CALCulate<n>:DELTamarker<m>:MINimum:NEXT.....	283
CALCulate<n>:DELTamarker<m>:MINimum[:PEAK].....	284
CALCulate<n>:DELTamarker<m>:MINimum:RIGHT.....	284

CALCulate<n>:DELTamarker<m>:FUNCTION:CPICH

Sets the delta marker to channel 0.

Is only available in "Code Domain Power" and "Code Domain Error Power" evaluations.

Suffix:

<n> Window

<m> Marker

Example: CALC:DELT2:FUNC:CPIC

CALCulate<n>:DELTamarker<m>:FUNCTION:PCCPch

Sets the delta marker to the position of the PCCPCH.

Is only available in code domain power and code domain error power evaluations.

Suffix:

<n> Window

<m> Marker

Example: CALC:DELT2:FUNC:PCCP

CALCulate<n>:DELTamarker<m>:MAXimum:LEFT

Moves a delta marker to the next positive peak value.

The search includes only measurement values to the left of the current marker position.

Suffix:

<n> Window

<m> Marker

Manual operation: See "Search Next Peak" on page 128

CALCulate<n>:DELTamarker<m>:MAXimum:NEXT

Moves a marker to the next positive peak value.

Suffix:

<n> 1..n
 Window

<m> 1..n
Marker

Manual operation: See ["Search Next Peak"](#) on page 128

CALCulate<n>:DELTaMarker<m>:MAXimum[:PEAK]

Moves a delta marker to the highest level.

If the marker is not yet active, the command first activates the marker.

Suffix:

<n> Window

<m> Marker

Manual operation: See ["Peak Search"](#) on page 128

CALCulate<n>:DELTaMarker<m>:MAXimum:RIGHT

Moves a delta marker to the next positive peak value on the trace.

The search includes only measurement values to the right of the current marker position.

Suffix:

<n> Window

<m> Marker

Manual operation: See ["Search Next Peak"](#) on page 128

CALCulate<n>:DELTaMarker<m>:MINimum:LEFT

Moves a delta marker to the next minimum peak value.

The search includes only measurement values to the right of the current marker position.

Suffix:

<n> Window

<m> Marker

Manual operation: See ["Search Next Minimum"](#) on page 128

CALCulate<n>:DELTaMarker<m>:MINimum:NEXT

Moves a marker to the next minimum peak value.

Suffix:

<n> Window

<m> Marker

Manual operation: See ["Search Next Minimum"](#) on page 128

CALCulate<n>:DELTaMarker<m>:MINimum[:PEAK]

Moves a delta marker to the minimum level.

If the marker is not yet active, the command first activates the marker.

Suffix:

<n> [Window](#)

<m> [Marker](#)

Manual operation: See "[Search Minimum](#)" on page 128

CALCulate<n>:DELTaMarker<m>:MINimum:RIGHT

Moves a delta marker to the next minimum peak value.

The search includes only measurement values to the right of the current marker position.

Suffix:

<n> [Window](#)

<m> [Marker](#)

Manual operation: See "[Search Next Minimum](#)" on page 128

11.11 Importing and exporting I/Q data and results

The I/Q data to be evaluated in the 3GPP FDD application can not only be measured by the 3GPP FDD application itself, it can also be imported to the application, provided it has the correct format. Furthermore, the evaluated I/Q data from the 3GPP FDD application can be exported for further analysis in external applications.

For details see [Chapter 4.9, "I/Q data import and export"](#), on page 56.

MMEMory:LOAD:IQ:STATE	284
MMEMory:STORe<n>:IQ:COMMeNt	285
MMEMory:STORe<n>:IQ:FORMat	285
MMEMory:STORe<n>:IQ:STATe	285

MMEMory:LOAD:IQ:STATE 1, <FileName>

Restores I/Q data from a file.

Setting parameters:

<FileName> string

String containing the path and name of the source file.

The file type is determined by the file extension. If no file extension is provided, the file type is assumed to be `.iq.tar`.

For `.mat` files, Matlab® v4 is assumed.

Example: MMEM:LOAD:IQ:STAT 1, 'C:
 \R_S\Instr\user\data.iq.tar'
 Loads IQ data from the specified file.

Usage: Setting only

MMEMory:STORe<n>:IQ:COMMeNt <Comment>

Adds a comment to a file that contains I/Q data.

Suffix:
 <n> irrelevant

Parameters:
 <Comment> String containing the comment.

Example: MMEM:STOR:IQ:COMM 'Device test 1b'
 Creates a description for the export file.
 MMEM:STOR:IQ:STAT 1, 'C:
 \R_S\Instr\user\data.iq.tar'
 Stores I/Q data and the comment to the specified file.

MMEMory:STORe<n>:IQ:FORMAt <Format>,<DataFormat>

Sets or queries the format of the I/Q data to be stored.

Suffix:
 <n> irrelevant

Parameters:
 <Format> **FLOat32**
 32-bit floating point format.
INT32
 32-bit integer format.
 *RST: FLOat32

<DataFormat> **COMPLex**
 Exports complex data.
REAL
 Exports real data.
 *RST: COMPLex

Example: MMEM:STOR:IQ:FORM INT32,REAL

MMEMory:STORe<n>:IQ:STATe <1>, <FileName>

Writes the captured I/Q data to a file.

By default, the contents of the file are in 32-bit floating point format.

Suffix:
 <n> 1..n

Configuring the secondary application data range (MSRA mode only)

Parameters:

<1>

<FileName> String containing the path and name of the target file.
The file type is determined by the file extension. If no file extension is provided, the file type is assumed to be `.iq.tar`.
For `.mat` files, Matlab® v4 is assumed.

Example:

```
MMEM:STOR:IQ:STAT 1, 'C:
\R_S\Instr\user\data.iq.tar'
```

Stores the captured I/Q data to the specified file.

Usage:

Asynchronous command

11.12 Configuring the secondary application data range (MSRA mode only)

In MSRA operating mode, only the MSRA primary actually captures data; the MSRA secondary applications define an extract of the captured data for analysis, referred to as the **secondary application data**.

For the 3GPP FDD BTS secondary application, the secondary application data range is defined by the same commands used to define the signal capture in Signal and Spectrum Analyzer mode (see [\[SENSe:\]CDPower:IQLength](#) on page 204). Be sure to select the correct measurement channel before executing this command.

In addition, a capture offset can be defined, i.e. an offset from the start of the captured data to the start of the secondary application data for the 3GPP FDD BTS measurement.

The **analysis interval** used by the individual result displays cannot be edited, but is determined automatically. However, you can query the currently used analysis interval for a specific window.

The **analysis line** is displayed by default but can be hidden or re-positioned.

Remote commands exclusive to MSRA secondary applications

The following commands are only available for MSRA secondary application channels:

CALCulate<n>:MSRA:ALINE:SHOW	286
CALCulate<n>:MSRA:ALINE[:VALue]	287
CALCulate<n>:MSRA:WINDow<n>:IVAL	287
INITiate<n>:REFresh	287
[SENSe:]MSRA:CAPTure:OFFSet	288

CALCulate<n>:MSRA:ALINE:SHOW

Defines whether or not the analysis line is displayed in all time-based windows in all MSRA secondary applications and the MSRA primary application.

Configuring the secondary application data range (MSRA mode only)

Note: even if the analysis line display is off, the indication whether or not the currently defined line position lies within the analysis interval of the active secondary application remains in the window title bars.

Suffix:

<n> irrelevant

Parameters:

<State> ON | OFF | 0 | 1
OFF | 0
 Switches the function off
ON | 1
 Switches the function on

CALCulate<n>:MSRA:ALine[:VALue] <Position>

Defines the position of the analysis line for all time-based windows in all MSRA secondary applications and the MSRA primary application.

Suffix:

<n> irrelevant

Parameters:

<Position> Position of the analysis line in seconds. The position must lie within the measurement time of the MSRA measurement.
 Default unit: s

CALCulate<n>:MSRA:WINDow<n>:IVAL

Returns the current analysis interval for applications in MSRA operating mode.

Suffix:

<n> irrelevant

<n> 1..n
[Window](#)

Return values:

<IntStart> Analysis start = Capture offset time
 Default unit: s
 <IntStop> Analysis end = capture offset + capture time
 Default unit: s

INITiate<n>:REFresh

Updates the current measurement results to reflect the current measurement settings.

No new I/Q data is captured. Thus, measurement settings apply to the I/Q data currently in the capture buffer.

The command applies exclusively to I/Q measurements. It requires I/Q data.

Suffix:	<n>	irrelevant
Example:	INIT:REFR	Updates the IQ measurement results.
Usage:		Asynchronous command
Manual operation:		See " Refresh (MSRA only) " on page 99

[SENSe:]MSRA:CAPTure:OFFSet <Offset>

This setting is only available for secondary applications in MSRA mode, not for the MSRA primary application. It has a similar effect as the trigger offset in other measurements.

Parameters:

<Offset>	This parameter defines the time offset between the capture buffer start and the start of the extracted secondary application data. The offset must be a positive value, as the secondary application can only analyze data that is contained in the capture buffer.
Range:	0 to <Record length>
*RST:	0
Default unit:	S

Manual operation: See "[Capture Offset](#)" on page 84

11.13 Querying the status registers

The following commands are required for the status reporting system specific to the 3GPP FDD applications. In addition, the 3GPP FDD applications also use the standard status registers of the FSW (depending on the measurement type).

For details on the common FSW status registers refer to the description of remote control basics in the FSW User Manual.



*RST does not influence the status registers.



The STATus:QUEStionable:DIQ register is described in "[STATus:QUEStionable:DIQ register](#)" on page 176.

The STATus:QUEStionable:SYNC register contains application-specific information about synchronization errors or errors during pilot symbol detection.

Table 11-10: Status error bits in STATus:QUESTionable:SYNC register for 3GPP FDD applications

Bit	Definition
0	Not used.
1	<p>Frame Sync failed</p> <p>This bit is set when synchronization is not possible within the application.</p> <p>Possible reasons:</p> <ul style="list-style-type: none"> • Incorrectly set frequency • Incorrectly set level • Incorrectly set scrambling code • Incorrectly set values for Q-INVERT or SIDE BAND INVERT • Invalid signal at input • Antenna 1 synchronization is not possible ("Time Alignment Error" measurements, 3GPP FDD BTS only)
2	<p>For "Time Alignment Error" measurements (3GPP FDD BTS only): bit is set if antenna 2 synchronization is not possible;</p> <p>Otherwise: not used.</p>
3 to 4	Not used.
5	<p>Incorrect Pilot Symbol</p> <p>This bit is set when one or more of the received pilot symbols are not equal to the specified pilot symbols of the 3GPP standard.</p> <p>Possible reasons:</p> <ul style="list-style-type: none"> • Incorrectly sent pilot symbols in the received frame. • Low signal to noise ratio (SNR) of the W-CDMA signal. • One or more code channels has a significantly lower power level compared to the total power. The incorrect pilots are detected in these channels because of low channel SNR. • One or more channels are sent with high power ramping. In slots with low relative power to total power, the pilot symbols might be detected incorrectly (check the signal quality by using the symbol constellation display).
6 to 14	Not used.
15	This bit is always 0.

STATus:QUESTionable:SYNC[:EVENT]?	289
STATus:QUESTionable:SYNC:CONDition?	290
STATus:QUESTionable:SYNC:ENABle	290
STATus:QUESTionable:SYNC:NTRansition	290
STATus:QUESTionable:SYNC:PTRansition	290

STATus:QUESTionable:SYNC[:EVENT]? <ChannelName>

Reads out the EVENT section of the status register.

The command also deletes the contents of the EVENT section.

Query parameters:

<ChannelName> String containing the name of the channel.
The parameter is optional. If you omit it, the command works for the currently active channel.

Usage: Query only

STATus:QUESTIONable:SYNC:CONDition? <ChannelName>

Reads out the CONDition section of the status register.

The command does not delete the contents of the EVENT section.

Query parameters:

<ChannelName> String containing the name of the channel.
The parameter is optional. If you omit it, the command works for the currently active channel.

Usage: Query only

STATus:QUESTIONable:SYNC:ENABLE <BitDefinition>, <ChannelName>

Controls the ENABLE part of a register.

The ENABLE part allows true conditions in the EVENT part of the status register to be reported in the summary bit. If a bit is 1 in the enable register and its associated event bit transitions to true, a positive transition will occur in the summary bit reported to the next higher level.

Parameters:

<BitDefinition> Range: 0 to 65535

<ChannelName> String containing the name of the channel.
The parameter is optional. If you omit it, the command works for the currently active channel.

STATus:QUESTIONable:SYNC:NTRansition <BitDefinition>[,<ChannelName>]

Controls the Negative TRansition part of a register.

Setting a bit causes a 1 to 0 transition in the corresponding bit of the associated register. The transition also writes a 1 into the associated bit of the corresponding EVENT register.

Parameters:

<BitDefinition> Range: 0 to 65535

<ChannelName> String containing the name of the channel.
The parameter is optional. If you omit it, the command works for the currently active channel.

STATus:QUESTIONable:SYNC:PTRansition <BitDefinition>[,<ChannelName>]

These commands control the Positive TRansition part of a register.

Setting a bit causes a 0 to 1 transition in the corresponding bit of the associated register. The transition also writes a 1 into the associated bit of the corresponding EVENT register.

Parameters:

<BitDefinition> Range: 0 to 65535

<ChannelName> String containing the name of the channel.
The parameter is optional. If you omit it, the command works for the currently active channel.

11.14 Deprecated commands

The following commands are provided for compatibility to other signal analyzers only. For new remote control programs use the specified alternative commands.

CALCulate<n>:FEED.....	291
[SENSe:]CDPower:LEVel:ADJust.....	292
[SENSe:]CDPower:PRESet.....	292
[SENSe:]CDPower:UCPich:CODE.....	293
[SENSe:]CDPower:UCPich:ANTenna<antenna>:PATtern.....	293
[SENSe:]CDPower:UCPich:ANTenna<antenna>[:STATE].....	293
[SENSe:]CDPower:UCPich[:STATE].....	294
[SENSe:]CDPower:QINVert.....	294

CALCulate<n>:FEED <Evaluation>

Selects the evaluation method of the measured data that is to be displayed in the specified window.

Note that this command is maintained for compatibility reasons only. Use the LAYout commands for new remote control programs (see [Chapter 11.7.2, "Working with windows in the display"](#), on page 234).

Suffix:

<n> 1..n
[Window](#)

Parameters:

<Evaluation> Type of evaluation you want to display.
See the table below for available parameter values.

Example:

```
INST:SEL BWCD
Activates 3GPP FDD BTS mode.
CALC:FEED CDP
Selects the display of the code domain power.
```

Table 11-11: <Evaluation> parameter values for 3GPP FDD applications

String Parameter	Enum Parameter	Evaluation
'XTIM:CDP:BSTream'	BITStream	"Bitstream"
'XTIM:CDP:COMP:CONStellation'	CCONst	"Composite Constellation"
'XPOW:CDEPower'	CDEPower	"Code Domain Error Power"
*) Use [SENS:]CDP:PDIS ABS REL subsequently to change the scaling		

String Parameter	Enum Parameter	Evaluation
'XPOW:CDP' 'XPOW:CDP:ABSolute'	CDPower	"Code Domain Power" (absolute scaling)
'XPOW:CDP:RATio'	CDPower	"Code Domain Power" (relative scaling) *)
'XTIM:CDP:MACCuracy'	CEVM	"Composite EVM"
'XTIM:CDP:ERR:CTable'	CTABLE	"Channel Table"
'XTIMe:CDP:CHIP:EVM'	EVMChip	"EVM vs Chip"
'XTIM:CDP:FVSLot'	FESLot	"Frequency Error vs Slot"
'XTIMe:CDP:CHIP:MAGNitude'	MEChip	Magnitude Error vs Chip
'XTIM:CDP:ERR:PCDomain'	PCDerror	"Peak Code Domain Error"
'XTIM:CDPower:PSVSlot'	PDSLot	"Phase Discontinuity vs Slot"
'XTIMe:CDPower:CHIP:PHASe'	PECHip	"Phase Error vs Chip"
'XTIM:CDP:PVSLot' 'XTIM:CDP:PVSLot:ABSolute'	PSLot	"Power vs Slot" (absolute scaling)
'XTIM:CDP:PVSLot:RATio'	PSLot	"Power vs Slot" (relative scaling) *)
'XTIM:CDP:PVSymbol'	PSYMBOL	"Power vs Symbol"
'XTIM:CDP:ERR:SUMMary'	RSUMmary	"Result Summary"
'XPOW:CDP:RATio'	SCONst	"Symbol Constellation"
'XTIM:CDP:SYMB:EVM'	SEVM	"Symbol EVM"
'XTIMe:CDPower:SYMBOL:EVM:MAGNitude'	SMERror	"Symbol Magnitude Error"
'XTIMe:CDPower:SYMBOL:EVM:PHASe'	SPERror	"Symbol Phase Error"
*) Use [SENS:]CDP:PDIS ABS REL subsequently to change the scaling		

[SENSe:]CDPower:LEVel:ADJust

This command adjusts the reference level to the measured channel power. This ensures that the settings of the RF attenuation and the reference level are optimally adjusted to the signal level without overloading the FSW or limiting the dynamic range by an S/N ratio that is too small.

Note that this command is retained for compatibility reasons only. For new FSW programs use [SENSe:]ADJust:LEVel on page 222.

[SENSe:]CDPower:PRESet

Resets the 3GPP FDD channel to its predefined settings. Any RF measurement is aborted and the measurement type is reset to Code Domain Analysis.

Note that this command is retained for compatibility reasons only. For new FSW programs use `SYSTEM:PRESet:CHANnel[:EXEC]` on page 159.

[SENSe:]CDPower:UCPich:CODE <CodeNumber>

Sets the code number of the user defined CPICH used for signal analysis.

Only applies to antenna 1.

Note that this command is maintained for compatibility reasons only. Use `[SENSe:]CDPower:UCPich:ANTenna<antenna>:CODE` on page 205 for new remote control programs.

Parameters:

<CodeNumber> Range: 0 to 225
 *RST: 0

Example: SENS:CDP:UCP:CODE 10

Mode: BTS application only

[SENSe:]CDPower:UCPich:ANTenna<antenna>:PATTern <arg0>

Defines which pattern is used for signal analysis for the user-defined CPICH (see `[SENSe:]CDPower:UCPich:ANTenna<antenna>[:STATe]` on page 293).

Note: this command is equivalent to the command `[SENSe:]CDPower:UCPich:ANTenna<antenna>:PATTern` on page 293 for antenna 1.

Suffix:

<antenna> 1..n
 Antenna to be configured

Parameters:

<Pattern> 1 | 2
 1
 fixed usage of "Pattern 1" according to standard
 2
 fixed usage of "Pattern 2" according to standard
 *RST: 2

Example: SENS:CDP:UCP:ANT2:PATT 1

Mode: BTS application only

Manual operation: See "[S-CPICH Antenna Pattern](#)" on page 90

[SENSe:]CDPower:UCPich:ANTenna<antenna>[:STATe] <State>

Defines whether the common pilot channel (CPICH) is defined by a user-defined position instead of its default position.

Note: this command is equivalent to the command `[SENSe:]CDPower:UCPich:ANTenna<antenna>[:STATe]` on page 293 for antenna 1.

Suffix:

<antenna> 1..n
Antenna to be configured

Parameters:

<State> 0
Standard configuration (CPICH is always on channel 0)
1
User-defined configuration, position defined using `[SENSe:]CDPower:UCPich:ANTenna<antenna>:CODE` on page 205.
*RST: 0

Example: SENS:CDP:CPIC:ANT2:STAT 1

Mode: BTS application only

Manual operation: See "CPICH Mode" on page 90

[SENSe:]CDPower:UCPich[:STATe] <State>

Defines whether the common pilot channel (CPICH) is defined by a user-defined position instead of its default position.

If enabled, the user-defined position must be defined using `[SENSe:]CDPower:UCPich:CODE` on page 293.

Only applies to antenna 1.

Note that this command is maintained for compatibility reasons only. Use `[SENSe:]CDPower:UCPich:ANTenna<antenna>:CODE` on page 205 for new remote control programs.

Parameters:

<State> ON | OFF | 1 | 0
*RST: 0

Example: SENS:CDP:UCP ON

Mode: BTS application only

[SENSe:]CDPower:QINVert <State>

This command inverts the Q-branch of the signal.

Note that this command is maintained for compatibility reasons only. Use the `[SENSe:]SWAPiq` command for new remote control programs.

Parameters:

ON | OFF | 1 | 0 *RST: 0

11.15 Programming examples (FSW-k72)

The following programming examples are based on the measurement examples described in [Chapter 10, "Measurement examples"](#), on page 136 for manual operation.

The measurements are performed with an FSW equipped with option FSW-K72. Only the commands required to control the FSW-K72 application are provided, not the signal generator.

The measurements are performed using the following devices and accessories:

- The FSW with Application Firmware FSW-K72: 3GPP FDD BTS base station test
- The Vector Signal Generator R&S SMW100A with option R&S SMW-K42: digital standard 3GPP FDD (requires options R&S SMW-B10, R&S SMW-B13 and R&S SMW-B103)
- 1 coaxial cable, 50Ω, approx. 1 m, N connector
- 1 coaxial cable, 50Ω, approx. 1 m, BNC connector

Test setup

1. Connect the RF output of the R&S SMW200A to the input of the FSW.
2. Connect the reference input ([REF INPUT]) on the rear panel of the FSW to the reference input (REF OUT) on the rear panel of the R&S SMW200A (coaxial cable with BNC connectors).
3. Connect the external trigger input of the FSW ([TRIGGER INPUT]) to the external trigger output of the R&S SMW200A (TRIGOUT1 of PAR DATA).

Settings on the R&S SMW200A

Setting	value
Preset	
Frequency	2.1175 GHz
Level	0 dBm
Digital standard	3GPP FDD
Link direction	DOWN/FORWARD
Test model	Test_Model_1_16_channels
Base station	BTS 1
Digital standard - State	ON
Scrambling code	0000

The following measurements are described:

- [Measurement 1: measuring the signal channel power](#)..... 296
- [Measurement 2: determining the spectrum emission mask](#).....296
- [Measurement 3: measuring the relative code domain power](#)..... 298

- [Measurement 4: triggered measurement of relative code domain power](#)..... 300
- [Measurement 5: measuring the composite EVM](#)..... 300
- [Measurement 6: determining the peak code domain error](#)..... 301

11.15.1 Measurement 1: measuring the signal channel power

```
*RST
//Reset the instrument
INST:CRE:NEW BWCD,'BTSMeasurement'
//Activate a 3GPP FDD BTS measurement channel named "BTSMeasurement"
DISP:TRAC:Y:SCAL:RLEV 0
//Set the reference level to 0 dBm
FREQ:CENT 2.1175 GHz
//Set the center Frequency to 2.1175 GHz
CONF:WCDP:BTS:MEAS POW
//Select the power measurement
DISP:TRAC:Y:SCAL:AUTO ONCE
//Optimize the scaling of the y-axis for the current measurement
INIT:CONT OFF
//Stops continuous sweep
SWE:COUN 100
//Sets the number of sweeps to be performed to 100
INIT;*WAI
//Start a new measurement with 100 sweeps and wait for the end
CALC:MARK:FUNC:POW:RES? CPOW
//Retrieves the calculated total power value of the signal channel
//Result: -1.02 [dB]
TRAC:DATA? TRACE1
//Retrieve the trace data of the power measurement
//Result: -1.201362252,-1.173495054,-1.187217355,-1.186594367,-1.171583891,
//-1.188250422,-1.204138160,-1.181404829,-1.186317205,-1.197872400, [...]
```

Table 11-12: Trace results for power measurement

Frequency	Power level
-1.201362252	-1.173495054
-1.187217355	-1.186594367
-1.171583891	-1.188250422
...	...

11.15.2 Measurement 2: determining the spectrum emission mask

```
*RST
//Reset the instrument
INST:CRE:NEW BWCD,'BTSMeasurement'
//Activate a 3GPP FDD BTS measurement channel named "BTSMeasurement"
DISP:TRAC:Y:SCAL:RLEV 0
```



```

//Set the reference level to 0 dBm
FREQ:CENT 2.1175 GHz
//Set the center Frequency to 2.1175 GHz
CONF:WCDP:BTS:MEAS ESP
//Select the spectrum emission mask measurement
DISP:TRAC:Y:SCAL:AUTO ONCE
//Optimize the scaling of the y-axis for the current measurement
INIT:CONT OFF
//Stops continuous sweep
SWE:COUN 100
//Sets the number of sweeps to be performed to 100
INIT;*WAI
//Start a new measurement with 100 sweeps and wait for the end
CALC:MARK:FUNC:POW:RES? CPOW
//Retrieves the calculated channel power value of the reference channel
//Result: -36.013 [dBm]
CALC:LIM:FAIL?
//QBTSries the result of the limit check
//Result: 0 [passed]
TRAC:DATA? LIST
//Retrieves the peak list of the spectrum emission mask measurement
//Result:
//+1.000000000,-1.275000000E+007,-8.500000000E+006,+1.000000000E+006,+2.108782336E+009,
//-8.057177734E+001,-7.882799530E+001,-2.982799530E+001,+0.000000000,+0.000000000,+0.000000000

//+2.000000000,-8.500000000E+006,-7.500000000E+006,+1.000000000E+006,+2.109000064E+009,
//-8.158547211E+001,-7.984169006E+001,-3.084169006E+001,+0.000000000,+0.000000000,+0.000000000

//+3.000000000,-7.500000000E+006,-3.500000000E+006,+1.000000000E+006,+2.113987200E+009,
//-4.202708435E+001,-4.028330231E+001,-5.270565033,+0.000000000,+0.000000000,+0.000000000,

[...]

```

Table 11-13: Trace results for SEM measurement

R an ge N o.	Start freq. [Hz]	Stop freq. [Hz]	RBW [Hz]	Freq. peak power [Hz]	Abs. peak power [dBm]	Rel. peak power [%]	Delta to margin [dB]	Limit check result	-	-	-
1	+1.00000 0000	-1.27500 0000E +007	-8.50000 0000E +006	+1.00000 0000E +006	+2.10878 2336E +009	-8.05717 7734E +001	-7.88279 9530E +001	-2.982 79953 0E +001	+	+	+0
2	+2.00000 0000	-8.50000 0000E +006	-7.50000 0000E +006	+1.00000 0000E +006	+2.10900 0064E +009	-8.15854 7211E +001	-7.98416 9006E +001	-3.084 16900 6E +001	+	+	+0
3	+3.00000 0000	-7.50000 0000E +006	-3.50000 0000E +006	+1.00000 0000E +006	+2.11398 7200E +009	-4.20270 8435E +001	-4.02833 0231E +001	-5.270 56503 3	+	+	+0
...	...										

11.15.3 Measurement 3: measuring the relative code domain power

```

*RST
//Reset the instrument
INST:CRE:NEW BWCD, 'BTSMeasurement'
//Activate a 3GPP FDD BTS measurement channel named "BTSMeasurement"
DISP:TRAC:Y:SCAL:RLEV 10
//Set the reference level to 10 dBm
FREQ:CENT 2.1175 GHz
//Set the center Frequency to 2.1175 GHz
DISP:TRAC:Y:SCAL:AUTO ONCE
//Optimize the scaling of the y-axis for the current measurement
INIT:CONT OFF
//Stops continuous sweep
SWE:COUN 100
//Set the number of sweeps to be performed to 100
INIT;*WAI
//Start a new measurement with 100 sweeps and wait for the end
CALC:MARK:FUNC:WCDP:BTS:RES? CDPR
//Retrieve the relative code domain power
//Result: 0 [dB]
TRAC:DATA? TRACE1

```

```
//Retrieve the trace data of the code domain power measurement
//Result: +8.000000000,+0.000000000,-4.319848537,-3.011176586,+0.000000000,
//+2.000000000,+1.000000000,-4.318360806,-3.009688854,+1.000000000,
//+8.000000000,+0.000000000,-7.348078156E+001,-7.217211151E+001,+1.000000000,
// [...]
-----Synchronizing the Reference Frequencies-----

ROSC:SOUR EXT10
//Select the external Frequency from the REF INPUT 1.20 MHz connector as a reference

CALC:MARK:FUNC:WCDP:BTS:RES? FERR
//Query the carrier Frequency error
//Result: 0.1 [Hz]

-----Behaviour with Incorrect Scrambling Code-----

CDP:LCOD:DVAL 0001
//Change the scrambling code on the analyzer to 0001 (default is 0000)
TRAC:DATA? TRACE1
//Retrieve the trace data of the code domain power measurement
//Result: 1.000000000,+8.000000000,+7.700000000E+001,-2.991873932E+001,-2.861357307E+001,
//+0.000000000,+8.000000000,+7.800000000E+001,-2.892916107E+001,-2.762399483E+001,
//+1.000000000,+8.000000000,+7.800000000E+001,-2.856664085E+001,-2.726147461E+001,
// [...]
```

Table 11-14: Trace results for Relative Code Domain Power measurement (correct scrambling code)

Code class	Channel no.	Abs. power level [dBm]	Rel. power level [%]	Timing offset [chips]
+8.000000000	+0.000000000	-4.319848537	-3.011176586	+0.000000000
+2.000000000	+1.000000000	-4.318360806	-3.009688854	+1.000000000
+8.000000000	+0.000000000	-7.348078156E+001	-7.217211151E+001	+1.000000000
...	...			

Table 11-15: Trace results for Relative Code Domain Power measurement (incorrect scrambling code)

Code class	Channel no.	Abs. power level [dBm]	Rel. power level [%]	Timing offset [chips]
1.000000000	+8.000000000	+7.700000000E+001	-2.991873932E+001	-2.861357307E+001
+0.000000000	+8.000000000	+7.800000000E+001	-2.892916107E+001	-2.762399483E+001
+1.000000000	+8.000000000	+7.800000000E+001	-2.856664085E+001	-2.726147461E+001
...	...			

11.15.4 Measurement 4: triggered measurement of relative code domain power

```

*RST
//Reset the instrument
INST:CRE:NEW BWCD, 'BTSMeasurement'
//Activate a 3GPP FDD BTS measurement channel named "BTSMeasurement"
DISP:TRAC:Y:SCAL:RLEV 10
//Set the reference level to 10 dBm
FREQ:CENT 2.1175 GHz
//Set the center Frequency to 2.1175 GHz
CDP:LCOD:DVAL 0000
//Change the scrambling code on the analyzer to 0000
TRIG:SOUR EXT
//Set the trigger source to the external trigger
//(TRIGGER INPUT connector)
DISP:TRAC:Y:SCAL:AUTO ONCE
//Optimize the scaling of the y-axis for the current measurement
INIT:CONT OFF
//Stops continuous sweep
SWE:COUN 100
//Set the number of sweeps to be performed to 100
INIT;*WAI
//Start a new measurement with 100 sweeps and wait for the end
CALC:MARK:FUNC:WCDP:BTS:RES? TFR
//Retrieve the trigger to frame (the offset between trigger event and
// start of first captured frame)
//Result: 0.00599987013 [ms]

----- Compensating a delay of the trigger event to the first captured frame -----

TRIG:HOLD 100 us
//Change the trigger offset to 100 us (=trigger to frame value)
CALC:MARK:FUNC:WCDP:BTS:RES? TFR
//Retrieve the trigger to frame value
//Result: 0.00599987013 [ms]

```

11.15.5 Measurement 5: measuring the composite EVM

```

*RST
//Reset the instrument
INST:CRE:NEW BWCD, 'BTSMeasurement'
//Activate a 3GPP FDD BTS measurement channel named "BTSMeasurement"
DISP:TRAC:Y:SCAL:RLEV 10
//Set the reference level to 10 dBm
FREQ:CENT 2.1175 GHz
//Set the center Frequency to 2.1175 GHz
TRIG:SOUR EXT
//Set the trigger source to the external trigger

```

```

// (TRIGGER INPUT connector)
LAY:REPL '2','XTIM:CDP:MACC'
// Replace the second measurement window (Result Summary) by Composite EVM evaluation
DISP:WIND2:TRAC:Y:SCAL:AUTO ONCE
// Optimize the scaling of the y-axis for the Composite EVM measurement
INIT:CONT OFF
// Stops continuous sweep
SWE:COUN 100
// Set the number of sweeps to be performed to 100
INIT;*WAI
// Start a new measurement with 100 sweeps and wait for the end
TRAC2:DATA? TRACE1
// Retrieve the trace data of the composite EVM measurement
// Result: +0.000000000,+5.876136422E-001,
// +1.000000000,+5.916179419E-001,
// +2.000000000,+5.949081182E-001,
// [...]

```

Table 11-16: Trace results for Composite EVM measurement

(CPICH) Slot number	EVM
0	+5.876136422E-001
1	+5.916179419E-001
2	+5.949081182E-001
...	...

11.15.6 Measurement 6: determining the peak code domain error

```

*RST
// Reset the instrument
INST:CRE:NEW BWCD,'BTSMeasurement'
// Activate a 3GPP FDD BTS measurement channel named "BTSMeasurement"
DISP:TRAC:Y:SCAL:RLEV 10
// Set the reference level to 10 dBm
FREQ:CENT 2.1175 GHz
// Set the center Frequency to 2.1175 GHz
TRIG:SOUR EXT
// Set the trigger source to the external trigger
// (TRIGGER INPUT connector)
LAY:REPL '2','XTIM:CDP:ERR:PCD'
// Replace the second measurement window (Result Summary) by the
// Peak Code Domain Error evaluation
DISP:WIND2:TRAC:Y:SCAL:AUTO ONCE
// Optimize the scaling of the y-axis for the Composite EVM measurement
INIT:CONT OFF
// Stops continuous sweep
SWE:COUN 100
// Set the number of sweeps to be performed to 100

```

```
INIT;*WAI
//Start a new measurement with 100 sweeps and wait for the end
TRAC2:DATA? TRACE1
//Retrieve the trace data of the Peak Code Domain Error measurement
//Result: +0.000000000,-6.730751038E+001,
//+1.000000000,-6.687619019E+001,
//+2.000000000,-6.728615570E+001,
// [...]
```

Table 11-17: Trace results for Peak Code Domain Error measurement

Slot number	Peak Error
0	-6.730751038E+001
1	-6.687619019E+001
2	-6.728615570E+001
...	...

List of Commands (3GPP FDD)

[SENSe:]ADJust:ALL.....	220
[SENSe:]ADJust:CONFigure:HYSTeresis:LOWer.....	222
[SENSe:]ADJust:CONFigure:HYSTeresis:UPPer.....	222
[SENSe:]ADJust:CONFigure:LEVel:DURation.....	221
[SENSe:]ADJust:CONFigure:LEVel:DURation:MODE.....	221
[SENSe:]ADJust:LEVel.....	222
[SENSe:]AVERAge<n>:COUNT.....	218
[SENSe:]CDPower:ANTenna.....	161
[SENSe:]CDPower:BASE.....	204
[SENSe:]CDPower:CODE.....	223
[SENSe:]CDPower:CPB.....	225
[SENSe:]CDPower:ETCHips.....	227
[SENSe:]CDPower:FILTer[:STATe].....	204
[SENSe:]CDPower:FRAMe[:VALue].....	223
[SENSe:]CDPower:HSDPamode.....	162
[SENSe:]CDPower:HSLot.....	227
[SENSe:]CDPower:ICTReshold.....	209
[SENSe:]CDPower:IQLength.....	204
[SENSe:]CDPower:LCODE:DVALue.....	164
[SENSe:]CDPower:LCODE:SEARch:LIST.....	163
[SENSe:]CDPower:LCODE:SEARch[:IMMEDIATE].....	162
[SENSe:]CDPower:LCODE:TYPE.....	165
[SENSe:]CDPower:LCODE[:VALue].....	165
[SENSe:]CDPower:LEVel:ADJust.....	292
[SENSe:]CDPower:MAPPing.....	223
[SENSe:]CDPower:MIMO.....	163
[SENSe:]CDPower:NORMAlize.....	225
[SENSe:]CDPower:PCONTrol.....	164
[SENSe:]CDPower:PDIFf.....	226
[SENSe:]CDPower:PDISplay.....	225
[SENSe:]CDPower:PREFerence.....	226
[SENSe:]CDPower:PRESet.....	292
[SENSe:]CDPower:QINVert.....	294
[SENSe:]CDPower:QPSKonly.....	166
[SENSe:]CDPower:SBANd.....	204
[SENSe:]CDPower:SFACTor.....	166
[SENSe:]CDPower:SLOT.....	223
[SENSe:]CDPower:STYPe.....	206
[SENSe:]CDPower:UCPich:ANTenna<antenna>:CODE.....	205
[SENSe:]CDPower:UCPich:ANTenna<antenna>:PATTern.....	293
[SENSe:]CDPower:UCPich:ANTenna<antenna>[:STATe].....	293
[SENSe:]CDPower:UCPich:CODE.....	293
[SENSe:]CDPower:UCPich[:STATe].....	294
[SENSe:]FREQuency:CENTer.....	187
[SENSe:]FREQuency:CENTer:STEP.....	188
[SENSe:]FREQuency:CENTer:STEP:AUTO.....	188
[SENSe:]FREQuency:OFFSet.....	188

[SENSe:]MSRA:CAPTure:OFFSet.....	288
[SENSe:]PROBe<pb>:ID:PARTnumber?.....	181
[SENSe:]PROBe<pb>:ID:SRNumber?.....	182
[SENSe:]PROBe<pb>:SETup:ATTRatio.....	182
[SENSe:]PROBe<pb>:SETup:CMOFFset.....	182
[SENSe:]PROBe<pb>:SETup:DMOFFset.....	183
[SENSe:]PROBe<pb>:SETup:MODE.....	183
[SENSe:]PROBe<pb>:SETup:NAME?.....	184
[SENSe:]PROBe<pb>:SETup:NMOFFset.....	184
[SENSe:]PROBe<pb>:SETup:PMODE.....	184
[SENSe:]PROBe<pb>:SETup:PMOFFset.....	185
[SENSe:]PROBe<pb>:SETup:STATe?.....	185
[SENSe:]PROBe<pb>:SETup:TYPE?.....	186
[SENSe:]SWAPiq.....	205
[SENSe:]SWEep:COUNT.....	219
[SENSe:]TAERror:CARRier<c>:ANTenna<antenna>:CPICh.....	228
[SENSe:]TAERror:CARRier<c>:ANTenna<antenna>:PATtern.....	228
[SENSe:]TAERror:CARRier<c>:COUNT.....	229
[SENSe:]TAERror:CARRier<c>:DELeTe.....	229
[SENSe:]TAERror:CARRier<c>:INSert.....	229
[SENSe:]TAERror:CARRier<c>:OFFSet.....	230
[SENSe:]TAERror:CARRier<c>:SCODE.....	230
[SENSe:]TAERror:CATalog.....	231
[SENSe:]TAERror:DELeTe.....	231
[SENSe:]TAERror:NEW.....	231
[SENSe:]TAERror:PRESet.....	231
[SENSe:]TAERror:SAVE.....	232
ABORT.....	242
CALCulate<n>:CDPower:MAPPING.....	224
CALCulate<n>:DELTamarker<m>:AOFF.....	277
CALCulate<n>:DELTamarker<m>:FUNction:CPICh.....	282
CALCulate<n>:DELTamarker<m>:FUNction:PCCPch.....	282
CALCulate<n>:DELTamarker<m>:MAXimum:LEFT.....	282
CALCulate<n>:DELTamarker<m>:MAXimum:NEXT.....	282
CALCulate<n>:DELTamarker<m>:MAXimum:RIGHT.....	283
CALCulate<n>:DELTamarker<m>:MAXimum[:PEAK].....	283
CALCulate<n>:DELTamarker<m>:MINimum:LEFT.....	283
CALCulate<n>:DELTamarker<m>:MINimum:NEXT.....	283
CALCulate<n>:DELTamarker<m>:MINimum:RIGHT.....	284
CALCulate<n>:DELTamarker<m>:MINimum[:PEAK].....	284
CALCulate<n>:DELTamarker<m>:X.....	277
CALCulate<n>:DELTamarker<m>:X:RELative?.....	277
CALCulate<n>:DELTamarker<m>:Y?.....	278
CALCulate<n>:DELTamarker<m>[:STATe].....	276
CALCulate<n>:FEED.....	291
CALCulate<n>:LIMit:FAIL?.....	269
CALCulate<n>:MARKer<m>:AOFF.....	276
CALCulate<n>:MARKer<m>:FUNction:CPICh.....	279
CALCulate<n>:MARKer<m>:FUNction:PCCPch.....	279
CALCulate<n>:MARKer<m>:FUNction:POWer<sb>:RESult?.....	270

CALCulate<n>:MARKer<m>:FUNction:TAERror:RESult.....	247
CALCulate<n>:MARKer<m>:FUNction:WCDPower:MS:RESult?.....	248
CALCulate<n>:MARKer<m>:FUNction:WCDPower[:BTS]:RESult.....	250
CALCulate<n>:MARKer<m>:FUNction:ZOOM.....	224
CALCulate<n>:MARKer<m>:MAXimum:LEFT.....	280
CALCulate<n>:MARKer<m>:MAXimum:NEXT.....	280
CALCulate<n>:MARKer<m>:MAXimum:RIGHT.....	280
CALCulate<n>:MARKer<m>:MAXimum[:PEAK].....	280
CALCulate<n>:MARKer<m>:MINimum:LEFT.....	280
CALCulate<n>:MARKer<m>:MINimum:NEXT.....	281
CALCulate<n>:MARKer<m>:MINimum:RIGHT.....	281
CALCulate<n>:MARKer<m>:MINimum[:PEAK].....	281
CALCulate<n>:MARKer<m>:X.....	275
CALCulate<n>:MARKer<m>:Y?.....	276
CALCulate<n>:MARKer<m>[:STATe].....	275
CALCulate<n>:MSRA:ALIne:SHOW.....	286
CALCulate<n>:MSRA:ALIne[:VALue].....	287
CALCulate<n>:MSRA:WINDow<n>:IVAL.....	287
CALCulate<n>:STATistics:RESult<res>?.....	272
CALibration:AIQ:HATiming[:STATe].....	180
CONFigure:WCDPower:MS:CTABLE:CATalog.....	212
CONFigure:WCDPower:MS:CTABLE:COMMeNt.....	214
CONFigure:WCDPower:MS:CTABLE:COpy.....	212
CONFigure:WCDPower:MS:CTABLE:DATA.....	216
CONFigure:WCDPower:MS:CTABLE:DATA:HSDPcch.....	217
CONFigure:WCDPower:MS:CTABLE:DELeTe.....	212
CONFigure:WCDPower:MS:CTABLE:EDATa.....	217
CONFigure:WCDPower:MS:CTABLE:EDATa:EDPCch.....	218
CONFigure:WCDPower:MS:CTABLE:MTABLE.....	215
CONFigure:WCDPower:MS:CTABLE:NAME.....	214
CONFigure:WCDPower:MS:CTABLE:SELeCt.....	213
CONFigure:WCDPower:MS:CTABLE:TOFFset.....	208
CONFigure:WCDPower:MS:CTABLE[:STATe].....	211
CONFigure:WCDPower:MS:MEASurement.....	160
CONFigure:WCDPower[:BTS]:ASCaLe:STATe.....	220
CONFigure:WCDPower[:BTS]:CTABLE:CATalog.....	209
CONFigure:WCDPower[:BTS]:CTABLE:COMMeNt.....	213
CONFigure:WCDPower[:BTS]:CTABLE:COMPAre.....	208
CONFigure:WCDPower[:BTS]:CTABLE:COpy.....	210
CONFigure:WCDPower[:BTS]:CTABLE:DATA.....	215
CONFigure:WCDPower[:BTS]:CTABLE:DELeTe.....	211
CONFigure:WCDPower[:BTS]:CTABLE:MTABLE.....	214
CONFigure:WCDPower[:BTS]:CTABLE:NAME.....	214
CONFigure:WCDPower[:BTS]:CTABLE:SELeCt.....	211
CONFigure:WCDPower[:BTS]:CTABLE[:STATe].....	209
CONFigure:WCDPower[:BTS]:MCArrier:STATe.....	220
CONFigure:WCDPower[:BTS]:MEASurement.....	159
CONFigure:WCDPower[:BTS]:SCRAmbling:FORMat.....	164
CONFigure:WCDPower[:BTS]:STD.....	233
DIAGnostic:SERVice:NSORce.....	187

DISPlay:FORMat.....	234
DISPlay[:WINDow<n>]:MTABle.....	278
DISPlay[:WINDow<n>]:SIZE.....	234
DISPlay[:WINDow<n>]:TRACe<t>:Y[:SCALe]:MAXimum.....	191
DISPlay[:WINDow<n>]:TRACe<t>:Y[:SCALe]:MINimum.....	191
DISPlay[:WINDow<n>][:SUBWindow<w>]:TRACe<t>:MODE.....	273
DISPlay[:WINDow<n>][:SUBWindow<w>]:TRACe<t>:Y[:SCALe].....	189
DISPlay[:WINDow<n>][:SUBWindow<w>]:TRACe<t>:Y[:SCALe]:AUTO ONCE.....	190
DISPlay[:WINDow<n>][:SUBWindow<w>]:TRACe<t>:Y[:SCALe]:PDIVision.....	190
DISPlay[:WINDow<n>][:SUBWindow<w>]:TRACe<t>:Y[:SCALe]:RLEVel.....	190
DISPlay[:WINDow<n>][:SUBWindow<w>]:TRACe<t>:Y[:SCALe]:RLEVel:OFFSet.....	191
DISPlay[:WINDow<n>][:SUBWindow<w>]:TRACe<t>[:STATe].....	274
FORMat:DEXPort:DSEParator.....	268
FORMat:DEXPort:HEADer.....	269
FORMat:DEXPort:TRACes.....	269
FORMat[:DATA].....	258
INITiate:SEQuencer:ABORt.....	244
INITiate:SEQuencer:IMMediate.....	244
INITiate:SEQuencer:MODE.....	245
INITiate:SEQuencer:REFResh[:ALL].....	245
INITiate<n>:CONMeas.....	243
INITiate<n>:CONTinuous.....	243
INITiate<n>:REFResh.....	287
INITiate<n>[:IMMediate].....	244
INPut:ATTenuation.....	194
INPut:ATTenuation:AUTO.....	194
INPut:ATTenuation:PROTection:RESet.....	167
INPut:CONNector.....	167
INPut:COUPling.....	167
INPut:DIQ:CDEVice.....	173
INPut:DIQ:RANGe:COUPling.....	173
INPut:DIQ:RANGe[:UPPer].....	173
INPut:DIQ:RANGe[:UPPer]:AUTO.....	173
INPut:DIQ:RANGe[:UPPer]:UNIT.....	174
INPut:DIQ:SRATe.....	174
INPut:DIQ:SRATe:AUTO.....	174
INPut:DPAth.....	168
INPut:EATT.....	194
INPut:EATT:AUTO.....	195
INPut:EATT:STATe.....	195
INPut:EGAIIn[:STATe].....	192
INPut:FILE:PATH.....	170
INPut:FILTer:HPASs[:STATe].....	168
INPut:FILTer:YIG[:STATe].....	168
INPut:GAIN:STATe.....	192
INPut:GAIN[:VALue].....	193
INPut:IMPedance.....	169
INPut:IQ:BALanced[:STATe].....	179
INPut:IQ:FULLScale:AUTO.....	179
INPut:IQ:FULLScale[:LEVel].....	180

INPut:IQ:TYPE.....	180
INPut:SElect.....	169
INPut:TYPE.....	170
INSTRument:CREate:DUPLicate.....	155
INSTRument:CREate:REPLace.....	156
INSTRument:CREate[:NEW].....	155
INSTRument:DELeTe.....	156
INSTRument:LIST?.....	156
INSTRument:REName.....	158
INSTRument[:SElect].....	158
LAYout:ADD[:WINDow]?.....	235
LAYout:CATalog[:WINDow]?.....	237
LAYout:IDENtify[:WINDow]?.....	237
LAYout:MOVE[:WINDow].....	238
LAYout:REMove[:WINDow].....	238
LAYout:REPLace[:WINDow].....	238
LAYout:SPLitter.....	239
LAYout:WINDow<n>:ADD?.....	240
LAYout:WINDow<n>:IDENtify?.....	241
LAYout:WINDow<n>:REMove.....	241
LAYout:WINDow<n>:REPLace.....	241
MMEMory:LOAD:IQ:STATe.....	284
MMEMory:LOAD:IQ:STReam.....	171
MMEMory:LOAD:IQ:STReam:AUTO.....	171
MMEMory:LOAD:IQ:STReam:LIST?.....	172
MMEMory:STORe<n>:FINal.....	267
MMEMory:STORe<n>:IQ:COMMeNt.....	285
MMEMory:STORe<n>:IQ:FORMat.....	285
MMEMory:STORe<n>:IQ:STATe.....	285
MMEMory:STORe<n>:TRACe.....	268
OUTPut:DIQ[:STATe].....	174
OUTPut:TRIGger<tp>:DIRection.....	201
OUTPut:TRIGger<tp>:LEVel.....	201
OUTPut:TRIGger<tp>:OTYPe.....	202
OUTPut:TRIGger<tp>:PULSe:IMMediate.....	202
OUTPut:TRIGger<tp>:PULSe:LENGth.....	203
OUTPut<up>:DIQ:CDEvice?.....	175
STATus:QUEStionable:DIQ:CONDition?.....	177
STATus:QUEStionable:DIQ:ENABle.....	177
STATus:QUEStionable:DIQ:NTRansition.....	178
STATus:QUEStionable:DIQ:PTRansition.....	178
STATus:QUEStionable:DIQ[:EVENt]?.....	178
STATus:QUEStionable:SYNC:CONDition?.....	290
STATus:QUEStionable:SYNC:ENABle.....	290
STATus:QUEStionable:SYNC:NTRansition.....	290
STATus:QUEStionable:SYNC:PTRansition.....	290
STATus:QUEStionable:SYNC[:EVENt]?.....	289
SYSTem:PRESet:CHANnel[:EXEC].....	159
SYSTem:SEQuencer.....	246
SYSTem:SPEaker:VOLume.....	187

TRACe:IQ:FILE:REPetition:COUNT.....	172
TRACe<n>[:DATA].....	259
TRACe<n>[:DATA]?.....	260
TRACe<n>[:DATA]?.....	261
TRACe<n>[:DATA]?.....	262
TRACe<n>[:DATA]?.....	262
TRACe<n>[:DATA]?.....	263
TRACe<n>[:DATA]?.....	264
TRACe<n>[:DATA]?.....	265
TRACe<n>[:DATA]?.....	266
TRACe<n>[:DATA]?.....	267
TRIGger[:SEQuence]:DTIME.....	196
TRIGger[:SEQuence]:HOLDoff[:TIME].....	196
TRIGger[:SEQuence]:IFPower:HOLDoff.....	197
TRIGger[:SEQuence]:IFPower:HYSTeresis.....	197
TRIGger[:SEQuence]:LEVel:BBPower.....	197
TRIGger[:SEQuence]:LEVel:IFPower.....	198
TRIGger[:SEQuence]:LEVel:RFPower.....	199
TRIGger[:SEQuence]:LEVel:VIDeo.....	199
TRIGger[:SEQuence]:LEVel[:EXTErnal<port>].....	198
TRIGger[:SEQuence]:SLOPe.....	199
TRIGger[:SEQuence]:SOURce.....	199
TRIGger[:SEQuence]:TIME:RINTerval.....	201

Index

Symbols

3GPP FDD	
Basics	42
Measurement examples	136
Measurements	16
Programming examples	295
Remote control	149
RF measurements	35

A

Aborting	
Sweep	98, 99
AC/DC coupling	69
ACLR	
3GPP FDD results	36
Configuration (3GPP FDD)	109
Results (remote)	270
RF Combi	37
Activating	
3GPP FDD measurements (remote)	155
Adjacent channel leakage ratio	
see ACLR	36
Amplitude	
Configuration	74
Configuration (remote)	189
Settings	74
Analog Baseband	
Input	71
Analysis	
BTS Code Domain Settings	117, 119
Mode	88
Remote control	273
RF (remote)	233
RF measurements	114
Settings	114
Analysis interval	
MSRA	87, 89, 203
Analysis line	58
Antenna	
Diversity	64
Number	64
Synchronization	90
Application cards	11
Application notes	11
Attenuation	
Auto	76
Configuration (remote)	193
Displayed	14
Electronic	77
Manual	76
Option	77
Protective (remote)	167
Audio demodulation	
Volume (remote control)	187
Auto all	100
Auto level	
Hysteresis	102
Reference level	76, 101
Softkey	76, 101
Auto scaling	79

Auto scrambling code	
Softkey	65, 101
Auto settings	100
Meastime Auto	101
Meastime Manual	101
Remote control	219
Autosearch	
Channel detection	45
Scrambling code	65, 101
Average count	99
Avg Power Inact Chan	17
Avg. RCDE	17

B

Bandwidth	
Coverage, MSRA mode	58
Menu	60
Base station	
see BTS	12
Base transceiver station	
see BTS	12
Bitstream	
Evaluation	19
Parameter	119
Trace results	252
Branch	
Evaluation range	116, 117
Brochures	10
BTS	12
Standard (ACLR)	110

C

Capture Length	88
Capture offset	
MSRA applications	89
MSRA secondary applications	84, 88
Remote	288
Softkey	84, 88
Carrier frequency error	17
Relationship to synchronization mode	18
Carrier tables	
Copying	105
Creating	105
Deleting	105
Editing	105
Predefined	104
Selecting	104
CCDF	
3GPP FDD results	39
Configuration (3GPP FDD)	112
CDA	16
Analysis settings (BTS)	117
Analysis settings (UE)	119
Channel results	18
Configuring	60
Configuring (remote)	161
Evaluation settings BTS (remote)	224
Evaluation settings UE (remote)	226
Parameters	17
Performing	132
Results	17

- CDEP 17
 - Evaluation 23
 - Trace results 254
- CDP
 - Channel parameter 47
 - Channel table 97
 - Evaluation 22
 - Measurement example 139
 - Programming example 298
 - Trace results 254
- Center frequency 80
 - Measurement example 141
 - Softkey 80
 - Step size 80
- Ch. SF 22
- Channel
 - Creating (remote) 156
 - Deleting (remote) 156
 - Duplicating (remote) 155
 - Querying (remote) 156
 - Renaming (remote) 158
 - Replacing (remote) 156
- Channel bandwidth
 - MSRA mode 58
- Channel detection
 - Autosearch 45
 - Configuring 91
 - Methods 45
 - Predefined tables 45
 - Remote control 206, 207
 - Search mode 93
 - Softkey 91
- Channel number 97
- Channel power 18
 - ACLR, see ACLR 36
 - Measurement example 136
 - Programming example 296
- Channel table
 - Configuration 21
- Channel tables
 - Comparison 45, 93
 - Configuring 133
 - Configuring (remote) 213
 - Configuring channels (remote) 215, 216
 - Copying 94
 - Creating 94
 - Creating from input 95
 - Deleting 94
 - Details 96
 - Editing 94
 - Evaluation 20
 - Managing 93
 - Managing (remote) 209
 - Predefined 93
 - Restoring 94
 - Selecting 94
 - Settings 95
 - Sorting 96
 - Trace results 253
- Channel types 47
 - BTS 45
 - Compressed 47
 - Configuring in table 97
 - Control 45, 49
 - CPICH 44, 46
 - CPRSD 47
 - DPCCH 49
 - DPCH 44, 47
 - DPDCH 49
 - EDPCCH 49
 - EDPDCH 49
 - HSDPCCH 49
 - MIMO 48
 - Parameter values (remote) 206, 207
 - PCCPCH 44, 46
 - PICH 47
 - PSCH 46
 - SCCPCH 46
 - SCH 44, 46
 - Special 44
 - SSCH 46
 - Synchronization 45
 - UE 49
- Channels 42
 - Active 92, 98
 - Bandwidth 42
 - Displayed 14
 - Evaluation range 115
 - Inactive, showing 21
 - Mapping 18
 - No of Active 17
 - Number 42
 - State 98
- Chip rate error 17
- Chips 44
- Closing
 - Channels (remote) 156
 - Windows (remote) 241
- Code class
 - Relationship to spreading factor 43
 - Relationship to symbol rate 43
- Code domain 42
- Code Domain Analysis
 - see CDA 16
- Code domain error power
 - see CDEP 17
- Code Domain Power
 - see CDP 22
- Code domain settings
 - Softkey 117, 119
- Code number
 - see Channel number 42
- Code Power Display 118, 120
- Codes 42
 - Number per channel 43
- Complementary cumulative distribution function
 - see CCDF 39
- Composite Constellation
 - Evaluation 23
 - Trace results 255
- Composite EVM 17
 - Evaluation 24
 - Measurement example 145
 - Programming example 300
 - Trace results 255
- Compressed Mode 64
- Conflict
 - Channel table 98
- Constellation
 - Parameter B 119
- Constellation points
 - Mapping in MIMO channels 48
- Continue single sweep
 - Softkey 99

- Continuous sweep
 - Softkey 98
- Conventions
 - SCPI commands 150
- Copying
 - Channel (remote) 155
- CPICH 46
 - Mode 90
 - Power reference 118
 - Slot, displayed 14
 - Softkey 129
- CPRSD 47
- D**
- Data acquisition
 - MSRA 87, 89, 203
 - see Signal capturing 86
- Data format
 - Remote 269
- Data sheets 10
- DC offset
 - Analog Baseband (B71, remote control) 180
 - see IQ offset 118, 120
- Decimal separator
 - Trace export 123
- Delta markers
 - Defining 125
- Diagram footer information 15
- Diagrams
 - Evaluation method 40
 - Footer information 15
- Digital Baseband interface 73
 - Connected instrument 73
 - Output connection status (remote) 175
 - Output settings 72, 73
 - Status registers 176
- Digital I/Q
 - Connection information 73
 - Enhanced mode 83
 - Output settings 72
 - Output settings information 73
 - Triggering 83
- Digital output
 - Enabling 73
- Direct path
 - Input configuration 70
- Display Config
 - Softkey 16, 59
- DPCH 47
- Duplicating
 - Channel (remote) 155
- E**
- Electronic input attenuation 76, 77
- Eliminating
 - IQ offset 118, 120, 225
 - Tail chips 120
- Enhanced mode
 - Digital I/Q 83
- Errors
 - Device connections 176
 - IF OVLN 75
- Evaluation methods
 - Remote 235
- Evaluation range
 - Branch 116, 117
 - Channel 115
 - Remote control 223
 - Settings 114
 - Slot 116
 - Softkey 114
- Evaluations
 - Bitstream 119
 - CDA 19
 - RF 39
 - Selecting 16
 - TAE 34
- EVM
 - Symbol 18
- EVM vs Chip
 - Evaluation 25
 - Trace results 255
- Exporting
 - I/Q data 56, 60, 130
 - I/Q data (remote) 284
 - Measurement settings 123
 - Scrambling codes 66
 - Trace results (remote) 267
 - Traces 122
- External trigger 82
 - Level (remote) 198
- F**
- Filters
 - High-pass (RF input) 70
 - YIG (remote) 168
- Format
 - Data (remote) 269
 - Scrambling codes (BTS) 65
 - Scrambling codes (UE) 67
- Frames 44
 - Capture mode 88
 - Evaluation range 88, 116
 - Number to capture 88
 - Selected 88, 116
- Free Run
 - Trigger 82
- Frequency
 - Configuration 79
 - Configuration (remote) 187
 - Offset 81
- Frequency Error vs Slot
 - Evaluation 26
 - Trace results 255
- Frontend
 - Configuration 74
 - Configuration (remote) 187
- Full slot
 - Evaluation 119
- G**
- Getting started 9
- H**
- Half slot
 - Evaluation 119
- Hardware settings
 - CDA, Displayed 14

- High-pass filter
 - RF input 70
- HS-DPA/UPA 63, 67
- HS-PDSCH 47
- HS-SSCH 47
- Hysteresis
 - Lower (Auto level) 102
 - Upper (Auto level) 102
- I**
- I/Q data
 - Exporting 60
 - Exporting (remote) 284
 - Importing 60
 - Importing (remote) 284
 - Importing/Exporting 56, 130
- I/Q imbalance 17
- I/Q offset 17
- IF Power
 - Trigger 83
 - Trigger level (remote) 198
- Impedance
 - Setting 69
- Importing
 - I/Q data 56, 60, 130
 - I/Q data (remote) 284
- Inactive Channel Threshold 92
- Input
 - Coupling 69
 - Overload (remote) 167
 - RF 69
 - Settings 77
 - Source, connection errors 176
 - Source, Radio frequency (RF) 68
- Installation 12
- Instrument security procedures 10
- IQ offset
 - Eliminating 118, 120, 225
- K**
- Keys
 - MKR -> 127
 - Peak Search 128
 - RUN CONT 98
 - RUN SINGLE 99
- L**
- Lines
 - Menu 60
- LO feedthrough 70
- Lower Level Hysteresis 102
- M**
- Mag Error vs Chip
 - Evaluation 26
 - Trace results 255
- Mapping
 - Channel 18
 - Channel table 97
 - I/Q branches 97
- Marker Functions
 - Menu 60
- Marker table
 - Configuring 125
 - Evaluation method 27, 40
- Markers
 - Configuration (remote) 274, 278
 - Configuring 124
 - Configuring (softkey) 123
 - Deactivating 125
 - Delta markers 125
 - Minimum 128
 - Minimum (remote control) 279
 - Next minimum 128
 - Next minimum (remote control) 279
 - Next peak 128
 - Next peak (remote control) 279
 - Peak 128
 - Peak (remote control) 279
 - Positioning 127
 - Search settings 126
 - Setting to CPICH 129
 - Setting to PCCPCH 129
 - Settings (remote) 275
 - State 124
 - Table 126
 - Table (evaluation method) 27, 40
 - Type 125
- Maximizing
 - Windows (remote) 234
- Maximum
 - Y-axis 79
- Measurement examples
 - 3GPP FDD 136
 - Composite EVM 145
 - Incorrect center frequency 141
 - Incorrect scrambling code 142
 - PCDE 146
 - Reference frequency 140
 - Relative code domain power 139
 - SEM 137
 - Signal channel power 136
 - Triggered CDP 143
- Measurement time
 - Auto settings 101
- Measurement types
 - CDA 16
 - RF 35
 - TAE 34
- Measurements
 - Interval 119
 - Selecting 62
 - Selecting (remote) 159
 - Starting (remote) 242
- MIMO
 - Channel types 48
 - Mapping to constellation points 48
 - Measurement mode 64
- Minimum 128
- Marker positioning 128
- Next 128
- Y-axis 79
- MKR ->
 - Key 127
- Mobile station
 - see UE (user equipment) 12
- Modulation
 - Inverted (I/Q, remote) 205
 - Inverted (I/Q) 87

- Modulation type 18
- MSR ACLR
 - Results (remote) 270
- MSRA
 - Analysis interval 87, 89, 203
 - Operating mode 34, 57
 - RF measurements 35
- MSRA applications
 - Capture offset 89
- MSRA primary
 - Data coverage 58
- MSRA secondary applications
 - Capture offset (remote) 288
- Multiple
 - Measurement channels 13, 59
- N**
- Next Minimum 128
 - Marker positioning 128
- Next Peak 128
 - Marker positioning 128
- Noise
 - Source 72
- O**
- OBW
 - 3GPP FDD results 36
 - Configuration (3GPP FDD) 110
 - RF Combi 37
- Occupied bandwidth
 - see OBW 36
- Offset
 - Analysis interval 84, 88
 - Frequency 81
 - Reference level 76
 - Timing 17, 18, 93, 97
- Options
 - Electronic attenuation 77
 - High-pass filter 70
 - Preamplifier 78
- Output
 - Configuration 71
 - Configuration (remote) 186
 - Digital Baseband interface settings 72, 73
 - Digital Baseband interface status 175
 - Digital I/Q (remote) 174
 - Noise source 72
 - Power measurement, Configuration 110
 - Settings 71
 - Trigger 85
- Overload
 - RF input (remote) 167
- Overview
 - Configuration 3GPP FDD 61
- P**
- P-CPICH
 - Synchronization mode 90
- PCCPCH 46
 - Softkey 129
- PCDE
 - Evaluation 28
 - Measurement example 146
 - Programming example 301
 - Trace results 255
- Peak Code Domain Error
 - see PCDE 28
- Peak list
 - Evaluation method 41
- Peak search
 - Key 128
 - Mode 127
- Peaks
 - Marker positioning 128
 - Next 128
 - Softkey 128
- Performing
 - 3G FDD measurement 132
- Phase Discontinuity vs Slot
 - Evaluation 28
 - Trace results 256
- Phase Error vs Chip
 - Evaluation 29
 - Trace results 256
- PICH 47
- Pilot bits 44, 45
 - Channel table 97
 - Number of 18
- PilotL 22
- Pk CDE 17
- Power
 - Channel (Meas example) 136, 296
 - Channels 18, 36, 110
 - Control 45
 - Difference to previous slot 118
 - Displayed 14
 - Inactive channels 17
 - Reference 118, 120
- Power vs Slot
 - Evaluation 30
 - Trace results 256
- Power vs Symbol
 - Evaluation 31
 - Trace results 256
- Preamplifier
 - Setting 78
 - Softkey 78
- Predefined tables
 - Channel detection 45
- Presetting
 - Channels 62, 292
- Pretrigger 84
- Programming examples
 - 3GPP FDD 295
 - Composite EVM 300
 - Incorrect scrambling code 298
 - PCDE 301
 - Reference Frequency 298
 - Relative code domain power 298
 - SEM 296
 - Signal channel power 296
 - Triggered CDP 300
- Protection
 - RF input (remote) 167
- PSCH 46
- Pwr Abs/Pwr Rel 22

R

- Range
 - Scaling 79
- RCDE 18
 - Average 17
- Reference frequency
 - Measurement example 140
- Reference Frequency
 - Programming example 298
- Reference level 75
 - Auto level 76, 101
 - Displayed 14
 - Offset 76
 - Unit 75
 - Value 75
- Reference power 118
- Refreshing
 - MSRA secondary applications 99
 - Softkey 99
- Release notes 10
- Remote commands
 - Basics on syntax 150
 - Boolean values 153
 - Capitalization 151
 - Character data 154
 - Data blocks 154
 - Deprecated 291
 - Numeric values 152
 - Optional keywords 151
 - Parameters 152
 - Strings 154
 - Suffixes 151
- Resetting
 - RF input protection 167
- Restoring
 - Channel settings 62, 292
- Result display
 - Configuration 59
 - Configuration (remote) 233
- Result Display 13
- Result displays
 - Diagram 40
 - Marker table 27, 40
 - Peak list 41
 - Result Summary 40
- Result summary
 - Channel results 18
 - Evaluation 31
 - General results 17
 - Trace results 256
- Result Summary
 - Evaluation method 40
 - Result display 40
- Results 16
 - Calculated (remote) 247
 - Data format (remote) 269
 - Evaluating 114
 - Exporting 123
 - Exporting (remote) 267
 - Retrieving (remote) 246
 - RF (remote) 269
 - Trace (remote) 258
 - Trace data query (remote) 251
 - Updating the display 99
- Retrieving
 - Calculated results (remote) 247
 - Results (remote) 246
 - RF Results (remote) 269
 - Trace results (remote) 258
- RF attenuation
 - Auto 76
 - Manual 76
- RF Combi
 - Configuration (3GPP FDD) 111
 - Measurement 37
- RF input 68
 - Overload protection (remote) 167
 - Remote 166
- RF measurements
 - 3GPP FDD 35
 - Analysis 114
 - Analysis (remote) 233
 - Configuration 108
 - Configuration (remote) 232
 - MSRA 35
 - Performing 134
 - Results 35
 - Results (remote) 269
 - RF Combi 111
 - Selecting 109
 - Types 35
- RF Power
 - Trigger level (remote) 199
- RF signal power 36, 110
- RHO 17
- RRC Filter 88, 204
- RUN CONT
 - Key 98
- RUN SINGLE
 - Key 99

S

- S-CPICH
 - Antenna pattern 90
 - Code number 90
 - Synchronization mode 90
- Safety instructions 10
- Sample rate 87
 - Configuring in channel table 97
- Scaling
 - Amplitude range, automatically 79
 - Configuration, softkey 78
 - Y-axis 79
- SCCPCH 46
- Scrambling code 42
 - Autosearch 65, 101
 - BTS 64, 65
 - BTS (remote) 164
 - Measurement example 142
 - Programming example 298
 - Softkey 64
 - UE 66
- Screen layout 13
- Security procedures 10
- Select meas
 - Softkey 59
- SEM
 - 3GPP FDD results 38
 - Configuration (3GPP FDD) 111
 - Measurement example 137

- Programming example 296
- RF Combi 37
- Sequencer 13, 59
 - Activating (remote) 244
 - Remote 243
- Sequences
 - Aborting (remote) 244
 - Mode (remote) 245
- Service manual 9
- Settings
 - Overview 61
- Show inactive channels 21
- Signal capturing
 - Remote control 203
 - Softkey 86
- Signal description
 - BTS (remote) 161
 - BTS Configuration 63
 - Configuration 62
 - Remote control 161
 - Softkey 62
 - UE (remote) 165
 - UE Configuration 66
- Single sweep
 - Softkey 99
- Slope
 - Trigger 84, 199
- Slots 44
 - Capture mode 88
 - Channel 44
 - CPICH 44
 - Evaluation 119
 - Evaluation range 116
 - Number 18
 - Power difference 118
- Softkeys
 - Amplitude Config 74
 - Auto All 100
 - Auto Level 76, 101
 - Auto Scrambling Code 65, 101
 - Capture Offset 84, 88
 - Center 80
 - Channel Detection 91
 - Code Domain Settings 117, 119
 - Continue Single Sweep 99
 - Continuous Sweep 98
 - CPICH 129
 - Digital I/Q 83
 - Display Config 16, 59
 - Evaluation Range 114
 - External 82
 - Free Run 82
 - Frequency Config 79
 - IF Power 83
 - Lower Level Hysteresis 102
 - Marker Config 123
 - Meastime Auto 101
 - Meastime Manual 101
 - Min 128
 - Next Min 128
 - Next Peak 128
 - Norm/Delta 125
 - Outputs Config 71
 - PCCPCH 129
 - Peak 128
 - Preamp 78
 - Ref Level 75
 - Ref Level Offset 76
 - Refresh 99
 - RF Atten Auto 76
 - RF Atten Manual 76
 - Scale Config 78
 - Scrambling Code 64
 - Select Meas 59
 - Signal Capture 86
 - Signal Description 62
 - Single Sweep 99
 - Sweep Config 98
 - Sweep Count 99
 - Synchronization 89
 - Trace Config 120
 - Trigger Config 81
 - Trigger Offset 84
 - Upper Level Hysteresis 102
- Span
 - Menu 60
- Speaker
 - Remote control 187
- Specifications 10
- Specifics for
 - Configuration 62
- Spectrum Emission Mask
 - see SEM 38
- Spreading factor 42
 - Relationship to code class 43
 - Relationship to symbol rate 43
- SSCH 46
- Standard
 - BTS (ACLR) 110
- State
 - Channels 98
- Status
 - Display 22
- Status registers
 - 3GPP FDD 288
 - Contents 288
 - Querying 288
 - STAT:QUES:POW 167
 - STATus:QUESTIONable:DIQ 176
- Suffixes
 - Common 154
 - Remote commands 151
- Swap I/Q 87
 - Remote 205
- Sweep
 - Aborting 98, 99
 - Configuration (remote) 218
 - Configuration (softkey) 98
- Sweep Count 99
- Symbol Constellation
 - Evaluation 32
 - Trace results 257
- Symbol EVM 18
 - Evaluation 32
 - Trace results 257
- Symbol Magnitude Error
 - Evaluation 33
 - Trace results 258
- Symbol Phase Error
 - Evaluation 33
 - Trace results 258

- Symbol rate 22, 42
 - Displayed 14
 - Relationship to code class 43
 - Relationship to spreading factor 43
- Synchronization
 - Check (TAE) 55
 - Configuring 89
 - Remote control 205
 - Softkey 89
 - Type 90
- T**
- T Offs 22
- TAE
 - Configuration (remote) 161
 - Configuring 102
 - Determining 134
 - Measurement 34
- Tail chips
 - Eliminating 120
- Test models
 - BTS 50
 - UE 52
- Test setup
 - BTS 51
 - UE 53
- TFCI 22
 - Channel detection 97
- Time Alignment Error
 - Evaluation 35
 - see TAE 34
- Timing offset 17, 18
 - Configuring 97
 - Reference 93
- Traces
 - Configuration (remote) 273
 - Configuration (softkey) 120
 - Export format 123
 - Exporting 122, 123
 - Exporting (remote) 267
 - Mode 121
 - Mode (remote) 273
 - Results (remote) 258
- Trigger
 - Configuration (remote) 196
 - Configuration (softkey) 81
 - External (remote) 199
 - Measurement example 143
 - Offset 84
 - Output 85
 - Programming example 300
 - Slope 84, 199
 - to frame 17
- Trigger level 84
 - External trigger (remote) 198
 - IF Power (remote) 198
 - RF Power (remote) 199
- Trigger source 82
 - Digital I/Q 83
 - External 82
 - Free Run 82
 - IF Power 83
- Troubleshooting
 - Input overload 167
- Type
 - Scrambling codes (UE) 67
- U**
- UE (User equipment) 12
- Units
 - Reference level 75
- Updating
 - Result display 99
- Upper Level Hysteresis 102
- Use TFCI
 - Channel table 97
- V**
- Videos 11
- Volume
 - Remote control 187
- W**
- W-CDMA 12
- White papers 11
- Window title bar information 15
- Windows
 - Adding (remote) 235
 - Closing (remote) 241
 - Configuring 62
 - Layout (remote) 239
 - Maximizing (remote) 234
 - Querying (remote) 237
 - Replacing (remote) 238
 - Splitting (remote) 234
 - Types (remote) 235
- X**
- X-value
 - Marker 125
- Y**
- Y-maximum, Y-minimum
 - Scaling 79
- YIG-preselector
 - Activating/Deactivating 70
 - Activating/Deactivating (remote) 168