

R&S®CMQ SHIELDING CUBE

Specifications

R&S®CMQ200
R&S®CMQ500



Specifications
Version 02.00

ROHDE & SCHWARZ

Make ideas real



CONTENTS

Definitions	3
Features	4
R&S®CMQ200 shielding cube.....	4
R&S®CMQ500 shielding cube.....	5
Specifications.....	6
R&S®CMQ200 shielding cube.....	6
R&S®CMQ500 shielding cube.....	6
Core frame	6
R&S®CMQ-B20C electric open-close.....	6
R&S®CMQ-B21C pneumatic open-close.....	6
R&S®CMQ-B22C manual open-close	6
Dimensions.....	7
<i>Outer dimensions</i>	<i>7</i>
<i>Inner dimensions (shown for R&S®CMQ200 with R&S®CMQ-B201C)</i>	<i>9</i>
<i>Drawer interface dimensions.....</i>	<i>10</i>
<i>Table layout dimensions.....</i>	<i>10</i>
<i>Fixture layout dimensions.....</i>	<i>11</i>
Antenna characteristics	12
<i>Major parameters of Rohde & Schwarz measurement antenna kits.....</i>	<i>12</i>
<i>R&S®Vivaldi 5G peak realized gain (meas.)</i>	<i>12</i>
<i>R&S®Vivaldi 5G DP port to port isolation (meas.).....</i>	<i>12</i>
<i>R&S®Vivaldi 5G DP radiation pattern (meas.).....</i>	<i>13</i>
<i>R&S®CMQ overall system path loss (meas.).....</i>	<i>13</i>
Ordering information	14
Basic configuration of R&S®CMQ200.....	14
Basic configuration of R&S®CMQ500.....	14
OTA layout	14
RF setup.....	16
Extras	18
Glossary.....	21

Definitions

General

Product data applies under the following conditions:

- Three hours of storage at ambient temperature followed by 30 minutes of warm-up operation
- Specified environmental conditions met
- Recommended calibration interval adhered to
- All internal automatic adjustments performed, if applicable

Specifications with limits

Represent warranted product performance by means of a range of values for the specified parameter. These specifications are marked with limiting symbols such as $<$, \leq , $>$, \geq , \pm , or descriptions such as maximum, limit of, minimum. Compliance is ensured by testing or is derived from the design. Test limits are narrowed by guard bands to take into account measurement uncertainties, drift and aging, if applicable.

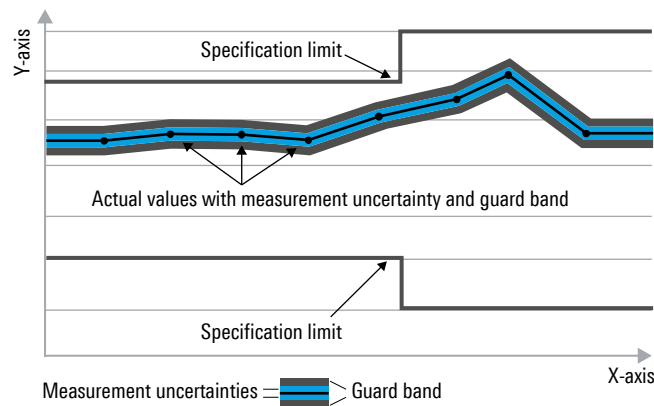

Non-traceable specifications with limits (n. trc.)

Represent product performance that is specified and tested as described under “Specifications with limits” above. However, product performance in this case cannot be warranted due to the lack of measuring equipment traceable to national metrology standards. In this case, measurements are referenced to standards used in the Rohde & Schwarz laboratories.

Specifications without limits

Represent warranted product performance for the specified parameter. These specifications are not specially marked and represent values with no or negligible deviations from the given value (e.g. dimensions or resolution of a setting parameter). Compliance is ensured by design.

Typical data (typ.)

Characterizes product performance by means of representative information for the given parameter. When marked with $<$, $>$ or as a range, it represents the performance met by approximately 80 % of the instruments at production time. Otherwise, it represents the mean value.

Nominal values (nom.)

Characterize product performance by means of a representative value for the given parameter (e.g. nominal impedance). In contrast to typical data, a statistical evaluation does not take place and the parameter is not tested during production.

Measured values (meas.)

Characterize expected product performance by means of measurement results gained from individual samples.

Uncertainties

Represent limits of measurement uncertainty for a given measurand. Uncertainty is defined with a coverage factor of 2 and has been calculated in line with the rules of the Guide to the Expression of Uncertainty in Measurement (GUM), taking into account environmental conditions, aging, wear and tear.

Device settings and GUI parameters are designated with the format “parameter: value”.

Non-traceable specifications with limits, typical data as well as nominal and measured values are not warranted by Rohde & Schwarz.

In line with the 3GPP standard, chip rates are specified in million chips per second (Mcps), whereas bit rates and symbol rates are specified in billion bit per second (Gbps), million bit per second (Mbps), thousand bit per second (kbps), million symbols per second (MSPS) or thousand symbols per second (ksps), and sample rates are specified in million samples per second (Msample/s). Gbps, Mcps, Mbps, MSPS, kbps, ksps and Msample/s are not SI units.

Features

R&S®CMQ200 shielding cube

The R&S®CMQ200 is a 19" shielding concept for efficient parametric testing of 5G FR2 devices and devices in the frequency range up to 14 GHz, as e.g. UWB. It addresses production test environments with a high number of loading cycles as well as regression test environments with very long test sequences. For best accuracy and repeatability, it is recommended to use the R&S®CMQ200 in combination with the R&S®CMP200 radio communication tester.

Ready for large quantities

- Fixed geometry, no positioners, speedy
- Multiple OTA test directions for different antenna layouts
- Integrated path switching
- Remote controlled
- Prepared for automated handling, drawer concept

Scalable for many devices

- Cradle concept for evolving antenna layouts
- Scalable for most devices/smart devices, CPEs, RFICs, prototypes
- Wide entry size: 35 cm x 35 cm (17 in x 17 in)
- Flexible number of measurement antennas
- Flexible positioning of measurement antennas at all 5 inner faces
- Support of different device layouts/fixtures for horizontal or upright loading
- Electric, pneumatic or manual open-close
- Frequency range from 0.3 GHz to 14 GHz and from 20 GHz to 77 GHz

Robust for millions of cycles

- Welded mainframe
- Evolution of well-known Rohde & Schwarz design
- Enables high device quality and fast rollout
- Integrated solution with Rohde & Schwarz testers for best link budget, accuracy and repeatability
- Same OTA environment in R&D and production
- Identical OTA measurement distance for different device sizes provides wide basis of statistical data



Front and rear view

R&S®CMQ500 shielding cube

The R&S®CMQ500 is a 19" shielding concept for efficient testing of 5G devices. It addresses network emulation scenarios (Rohde & Schwarz signaling mode) in regression test environments. For best accuracy and repeatability it is recommended to use the R&S®CMQ500 in combination with the R&S®CMX500 radio communication tester or the R&S®CMW500 wideband radio communication tester.

Ready for large quantities

- Fixed geometry, no positioners, speedy
- Multiple OTA test directions for different antenna layouts
- Integrated path switching
- Remote controlled
- Prepared for automated handling, drawer concept

Scalable for many devices

- Cradle concept for evolving antenna layouts
- Scalable for most devices/smart devices, CPEs, RFICs, prototypes
- Wide entry size: 35 cm x 35 cm (17 in x 17 in)
- Flexible number of measurement antennas
- Flexible positioning of measurement antennas at all 5 inner faces
- Support of different device layouts/fixtures for horizontal or upright loading
- Pneumatic or manual open-close
- Frequency range from 0.7 GHz to 77 GHz

Robust for millions of cycles

- Welded mainframe
- Evolution of well-known Rohde & Schwarz design
- Enables high device quality and fast rollout
- Integrated solution with Rohde & Schwarz testers for best link budget, accuracy and repeatability
- Same OTA environment in R&D and production
- Identical OTA measurement distance for different device sizes provides wide basis of statistical data



Front and rear view

Specifications

R&S®CMQ200 shielding cube

Frequency range	R&S®CMQ-B201C	20 GHz to 77 GHz
	R&S®CMQ-B221H	0.3 GHz to 14 GHz
Shielding effectiveness	R&S®CMQ-B201C	> 60 dB (typ.)
	R&S®CMQ-B221H	> 80 dB (typ.)

R&S®CMQ500 shielding cube

Frequency range	R&S®CMQ-B501H	0.7 GHz to 77 GHz
Shielding effectiveness	R&S®CMQ-B501H	> 80 dB (typ.)

Core frame

Reflectivity		< -20 dB (nom.)
Dimensions	outer dimensions, W x H x D	445 mm x 691 mm x 720 mm (17.5 in x 27.2 in x 28.3 in)
	front opening, W x H	350 mm x 350 mm (13.8 in x 13.8 in)
	drawer size, W x D	442 mm x 530 mm (17.4 in x 20.9 in)
	drawer stroke with absorber (open-close)	315 mm (12.4 in)
	rack mounting	19", 10 HU
Weight	without antenna cage	approx. 60 kg (110.2 lb)
Temperature range	operating temperature range	+5 °C to +45 °C
	storage temperature range	-20 °C to +60 °C
Relative humidity	operation	
	from +10 °C to +30 °C	90 % noncondensing
	from +10 °C to +40 °C	75 % noncondensing
	storage, up to +60 °C	90 % noncondensing
Power supply		100 to 240 V AC, 1.4 A
Feedthrough quantity	at rear	10
	at door	3
	at bottom rear	1
Cable guide	at drawer front, cable inserted at rear side, bottom feedthrough	1
Safety mechanism	integrated contusion protection on front drawer	reduced closing force of < 150 N (opening distance > 10 mm)

R&S®CMQ-B20C electric open-close

Door system control	remote open-close	D-Sub 9 (f), RJ-45
	manual open-close (electric support)	button on drawer

R&S®CMQ-B21C pneumatic open-close

Door system control	remote open-close	D-Sub 9 (f), RJ-45
	manual open-close (pneumatic support)	button on drawer
Interface	quick coupling plug KS3-1/8-A with additional push-pull adapter to 6 mm diameter flexible tubing	compressed air: 6 bar, max. 7 bar

R&S®CMQ-B22C manual open-close

Door system control	remote status query	D-Sub 9 (f), RJ-45
	manual open-close	door handle

Dimensions

Outer dimensions

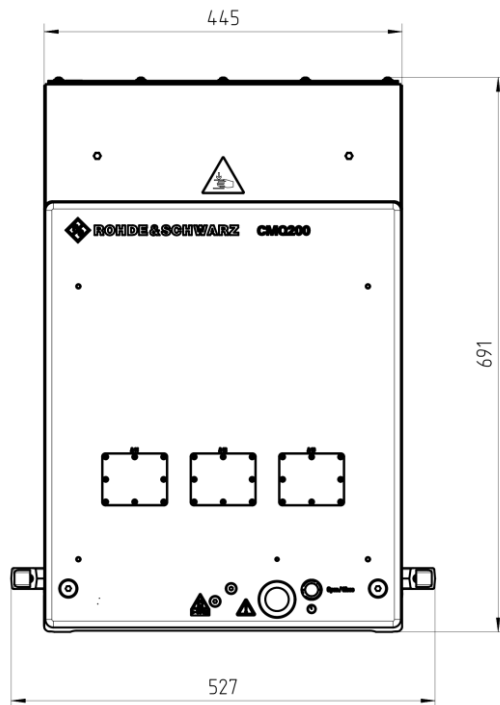

Front view, dimensions in mm

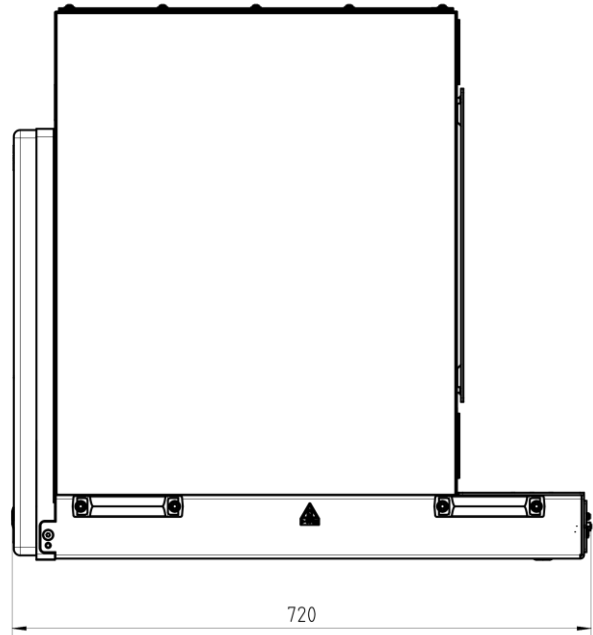

Side view with closed drawer, dimensions in mm

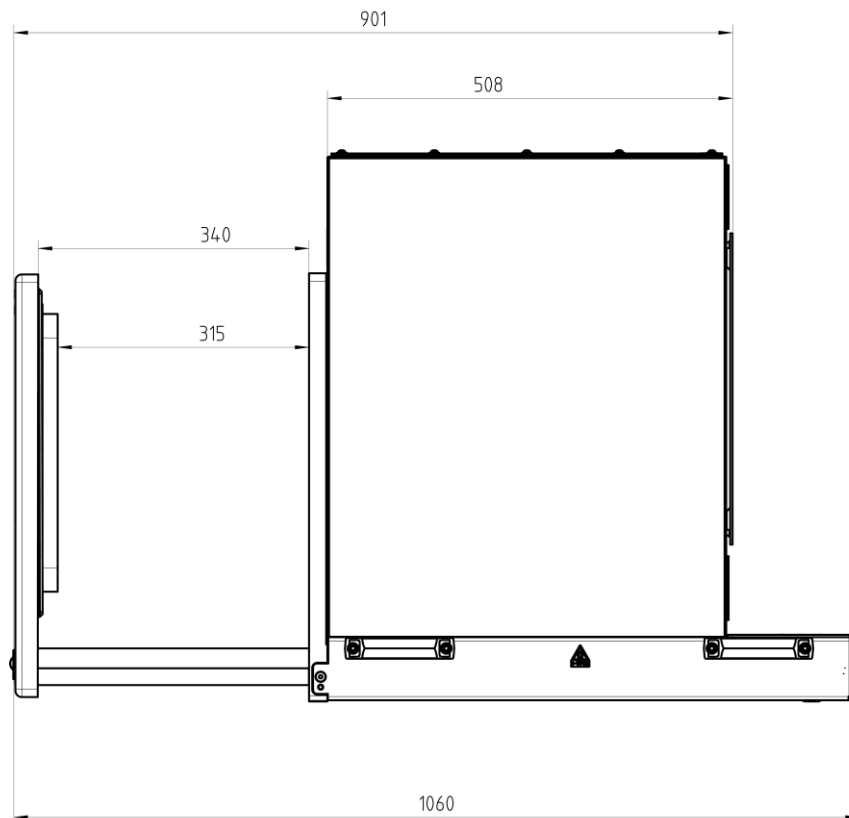

Side view with open drawer, dimensions in mm

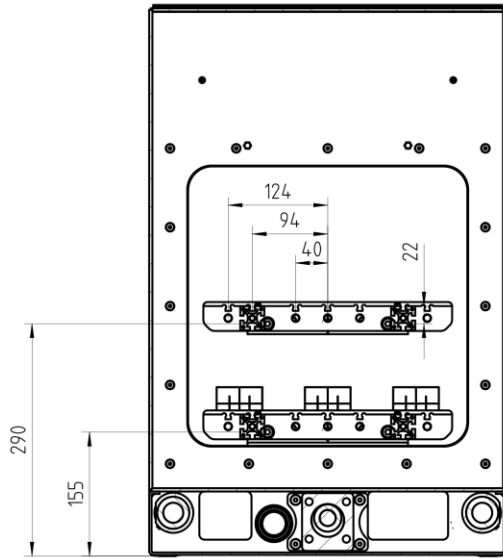

*Support mounting positions,
dimensions in mm*

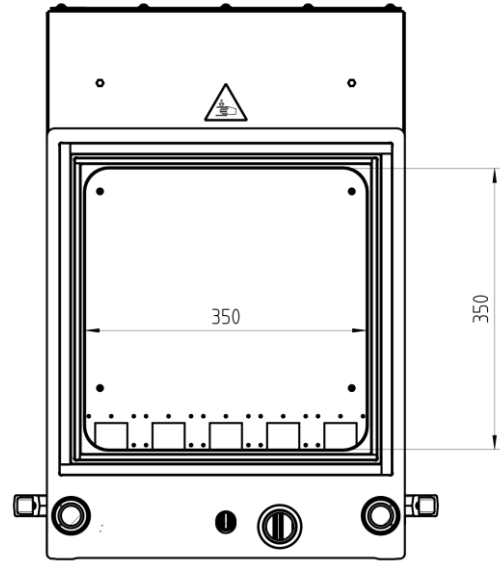

Opening width, dimensions in mm

Inner dimensions (shown for R&S®CMQ200 with R&S®CMQ-B201C)

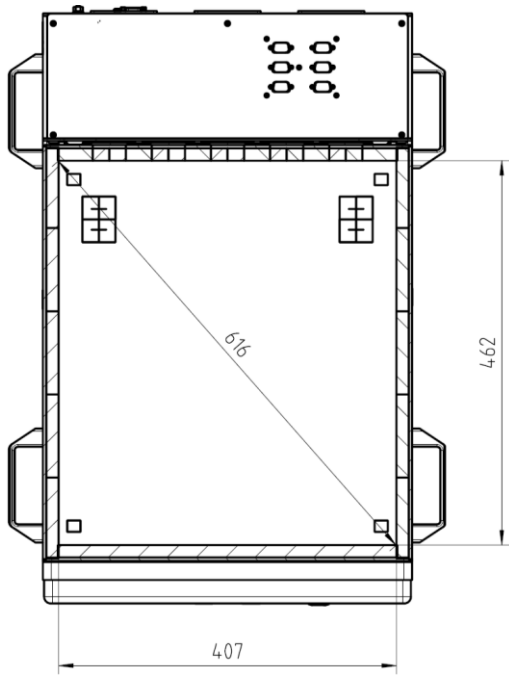

Inner dimensions in mm without antenna cradle, top view

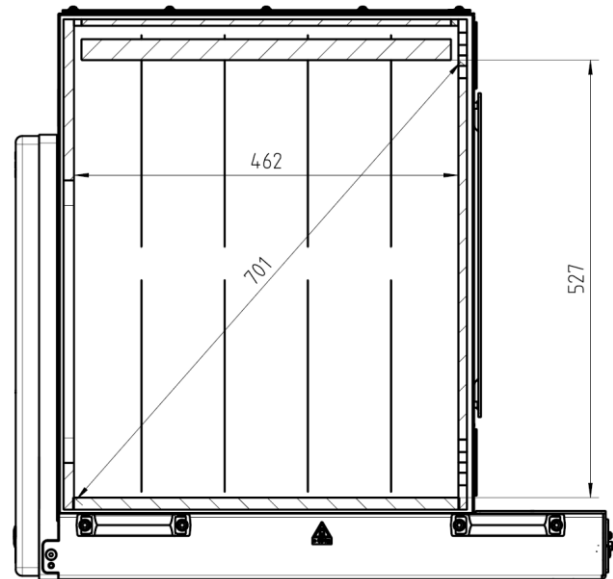

Inner dimensions in mm without antenna cradle, side view

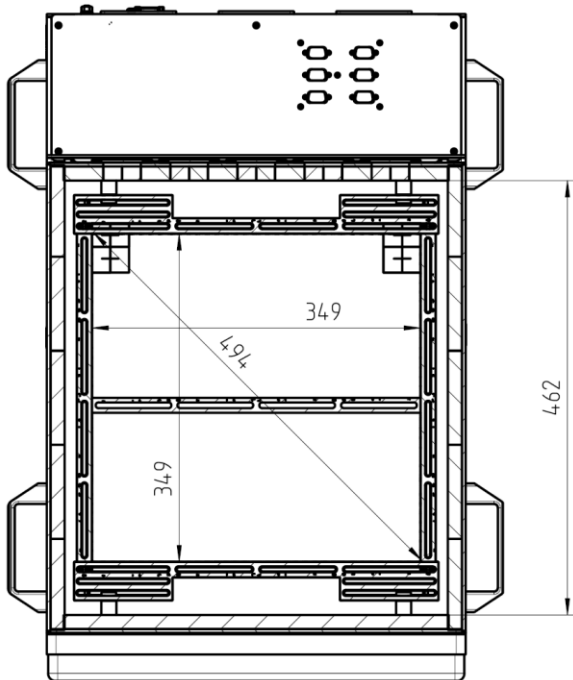

Inner dimensions in mm with antenna cradle, top view

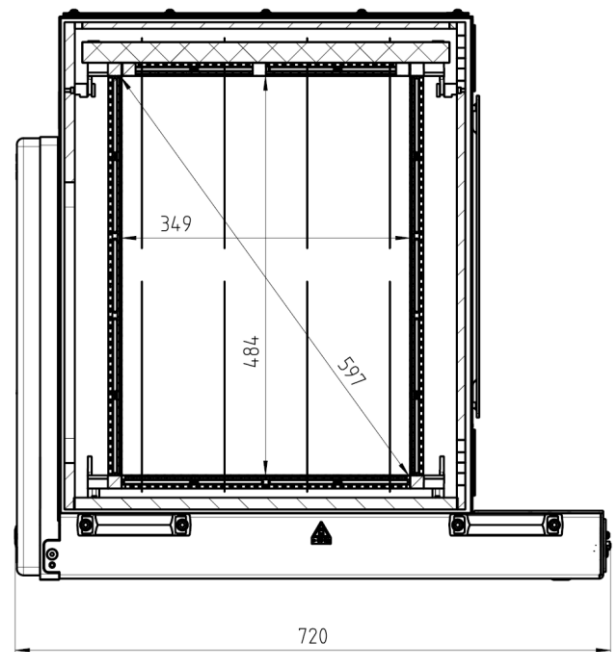

Inner dimensions in mm with antenna cradle, side view

Drawer interface dimensions

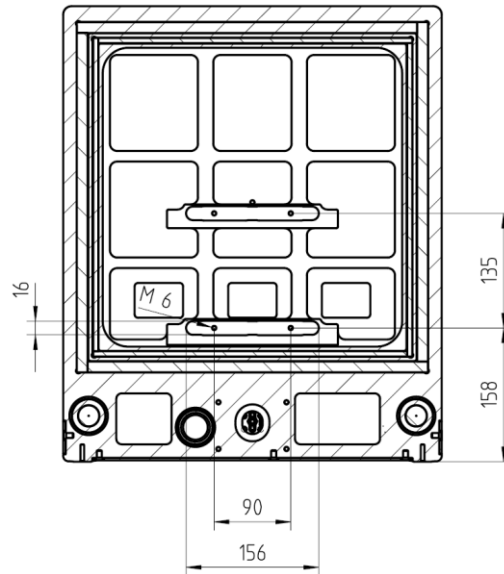

Inner mounting positions for drawer door, dimensions in mm

Table layout dimensions

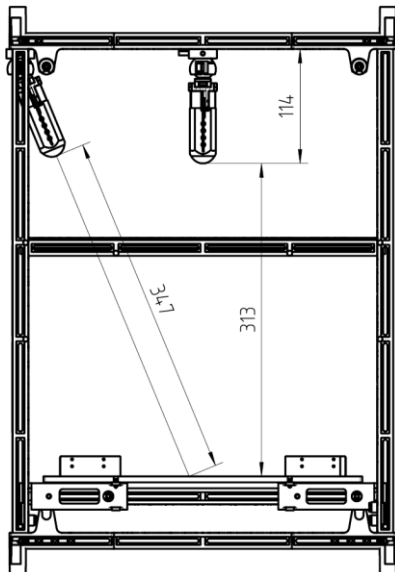

Inner table layout size limits in mm, front view
(with R&S[®]CMQ-B722A measurement antenna kit 2)

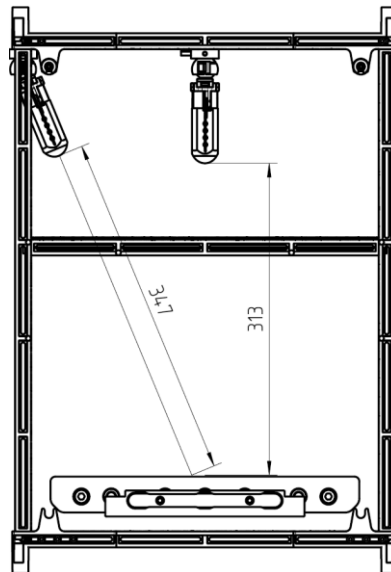

Drawer table layout size limits in mm, front view
(with R&S[®]CMQ-B722A measurement antenna kit 2)

Fixture layout dimensions

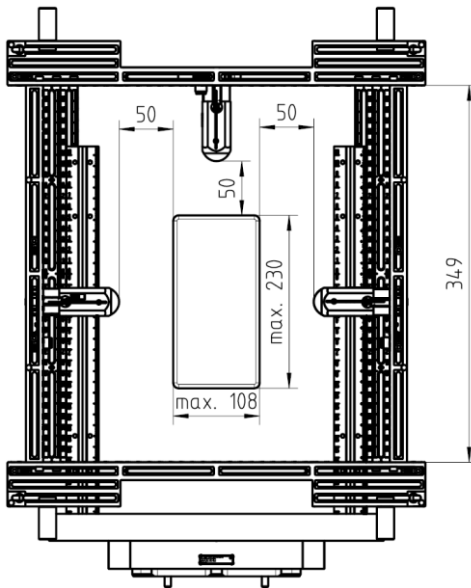

Fixture layout dimensions in mm, horizontal loading, top view;
maximum smart device size: 108 mm x 230 mm
(arrays at 3 edges, 50 mm OTA distance between
measurement antenna tip and device, device located at center)

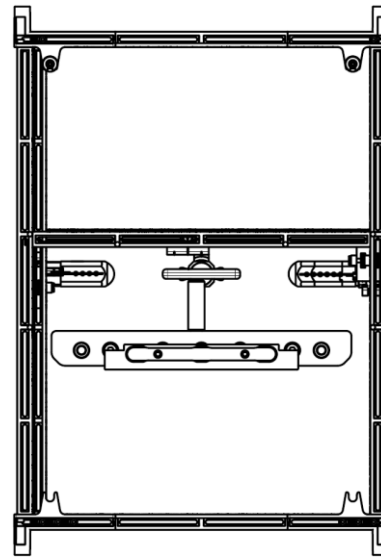

Fixture layout dimensions in mm, horizontal loading, front view;
products: antenna cradle (R&S®CMQ-700A) + drawer support
(R&S®CMQ-B712A) + device clamp 2 (R&S®CMQ-B715A)
+ 3 x measurement antenna kits 4 (R&S®CMQ-B724A)

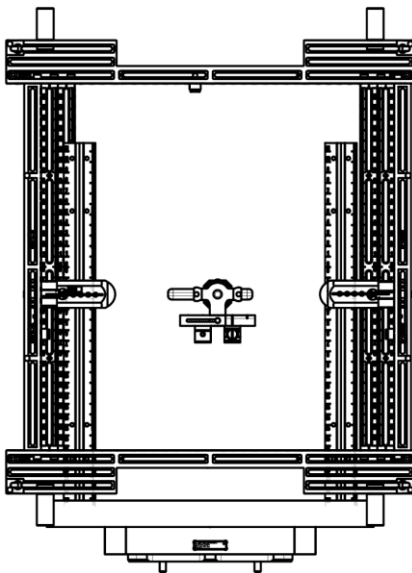

Fixture layout, upright loading, top view

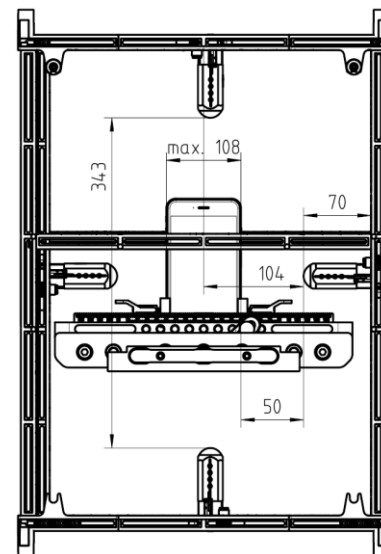

Fixture layout dimensions in mm, upright loading, front view;
products: antenna cradle (R&S®CMQ-B700A) +
drawer support (R&S®CMQ-B712A) +
device clamp 1 (R&S®CMQ-B714A) +
4 x measurement antenna kits 4 (R&S®CMQ-B724A);
maximum smart device size for upright loading:
108 mm x 243 mm
(arrays at 4 edges, 50 mm OTA distance between measurement
antenna tip and device, device located at center)

Antenna characteristics

Major parameters of Rohde & Schwarz measurement antenna kits

R&S®CMQ-B721/-B722/-B723/-B724, including R&S®Vivaldi 5G measurement antenna		
Nominal frequency range	R&S®CMQ-B721A/-B722A/-B723A/-B724A	20 GHz to 40 GHz
	R&S®CMQ-B721B/-B722B/-B723B/-B724B	20 GHz to 50 GHz
Gain		> 8 dBi
Polarization	R&S®CMQ-B721/-B723	single linear
	R&S®CMQ-B722/-B724	dual linear
VSWR		< -8 dB
RF connector type		MMPX connectors (female)
Impedance		50 Ω
Temperature	operating temperature range	+5 °C to +40 °C
	storage temperature range	-25 °C to +70 °C
Dimensions	W x H x D	78 mm x 30 mm x 30 mm (3.1 in x 1.18 in x 1.18 in)
Weight		approx. 0.1 kg (0.22 lb)

R&S®Vivaldi 5G peak realized gain (meas.)

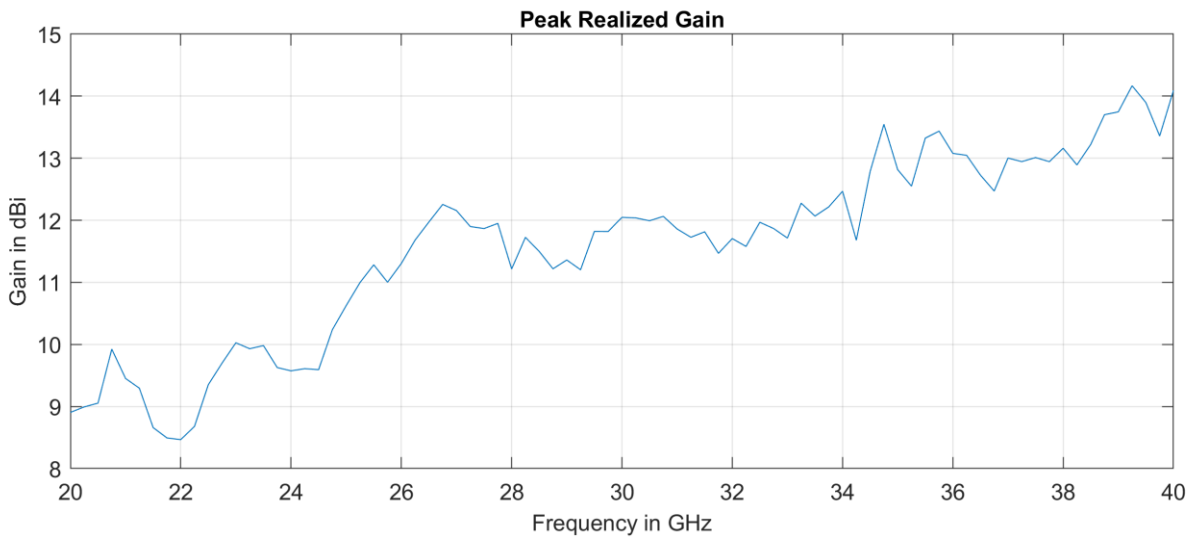

R&S®Vivaldi 5G DP port to port isolation (meas.)

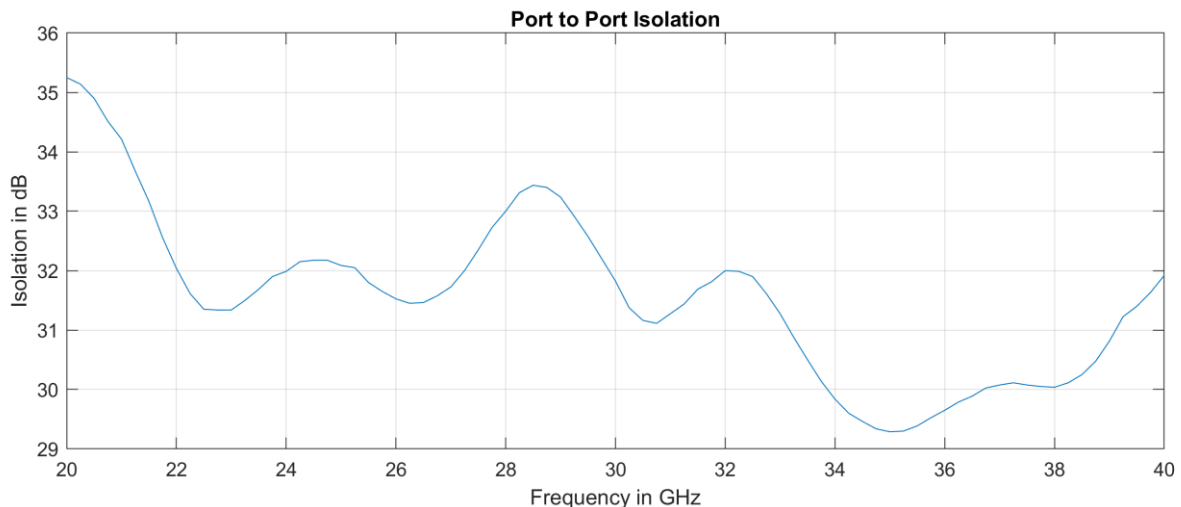

R&S® Vivaldi 5G DP radiation pattern (meas.)

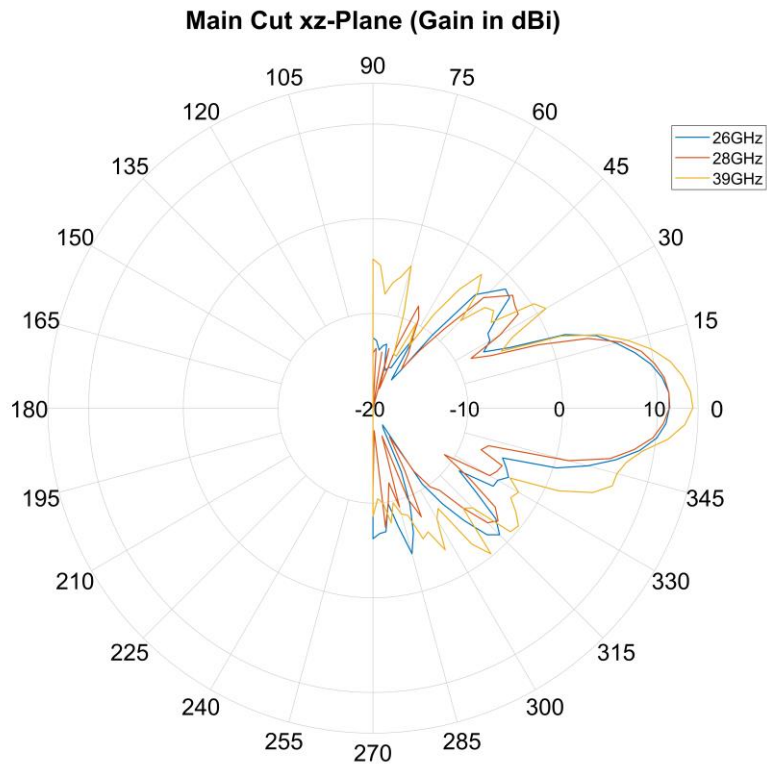

R&S® CMQ overall system path loss (meas.)

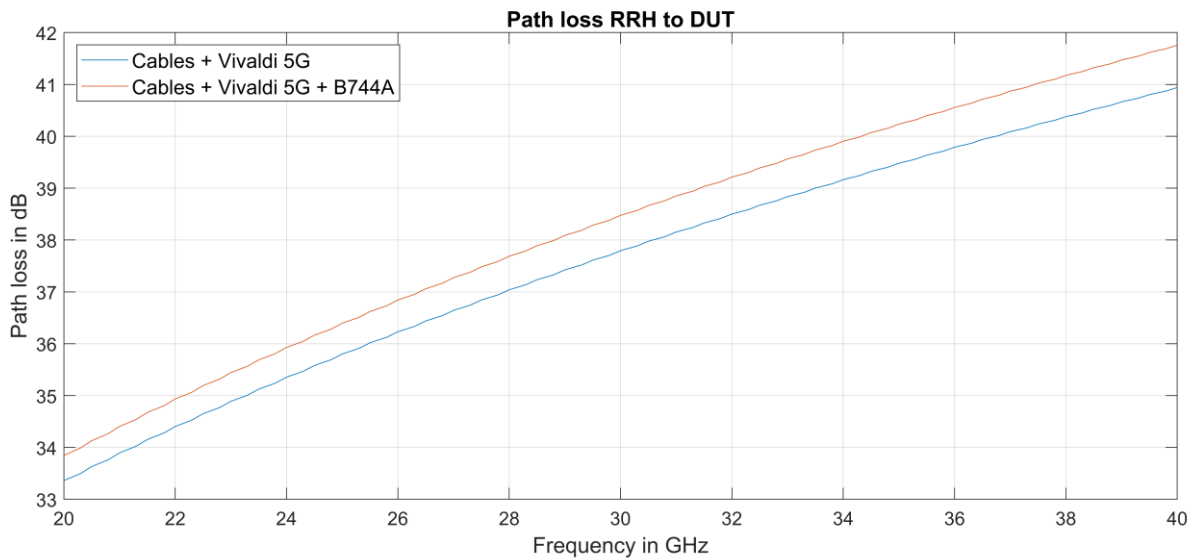

Path loss from Rohde & Schwarz remote radio head (RRH) RF interface towards device under test (50 mm OTA measurement distance between antenna tip and device edge)

Ordering information

Basic configuration of R&S®CMQ200

The basic configuration procedure is mandatory for each R&S®CMQ200. It provides the pure chamber with absorbers.

Designation	Type	Order No.
Shielded chamber		
Basic assembly	R&S®CMQB12C	1537.6003.04
Open-close mechanism		
Electrical open-close	R&S®CMQ-B20C	1537.6010.04
Pneumatic open-close	R&S®CMQ-B21C	1537.6026.04
Manual open-close	R&S®CMQ-B22C	1537.6078.04
Drawer front		
R&S®CMQ200 drawer front, 20 GHz to 77 GHz	R&S®CMQ-B201C	1537.6032.04
R&S®CMQ200 drawer front, high shielding, 0.3 GHz to 14 GHz	R&S®CMQ-B221H	1540.4014.04

Basic configuration of R&S®CMQ500



The basic configuration procedure is mandatory for each R&S®CMQ500. It provides the pure chamber with absorbers.

Designation	Type	Order No.
Shielded chamber		
Basic assembly	R&S®CMQB12C	1537.6003.04
Open-close mechanism		
Pneumatic open-close	R&S®CMQ-B21C	1537.6026.04
Manual open-close	R&S®CMQ-B22C	1537.6078.04
Drawer front		
R&S®CMQ500 drawer front, high shielding, 0.7 GHz to 77 GHz	R&S®CMQ-B501H	1540.4020.04

OTA layout

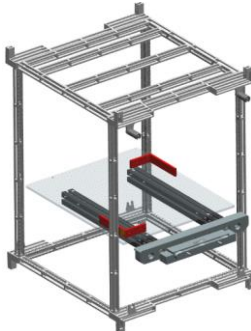
Depends on the FR2 device type and antenna location, any R&S®CMQ can be delivered with various preinstalled OTA layouts.

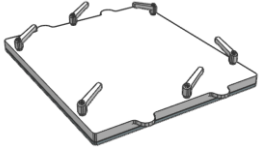
Designation	Type	Order No.	Description
Table layouts (recommended for single-face devices)			
Inner table layout, incl. antenna cradle and table 	R&S®CMQ-B701A	1537.6049.02	<ul style="list-style-type: none"> OTA setup for single-face devices comes with antenna cradle and table not with R&S®CMQ-B700A/-B702A table dimensions (W x D): 376 mm x 319 mm (14.8 in x 12.6 in) maximum device weight: 1 kg (2.2 lb)
Drawer table layout, incl. antenna cradle and table 	R&S®CMQ-B702A	1537.6110.02	<ul style="list-style-type: none"> OTA setup for single-face devices comes with antenna cradle and table table is mounted on drawer not with R&S®CMQ-B700A/-B701A table dimensions (W x D): 376 mm x 319 mm (14.8 in x 12.6 in) maximum device weight: 1.5 kg (3.3 lb)

Designation	Type	Order No.	Description
Fixture layouts (recommended for multi-face devices)			
Antenna cradle 	R&S®CMQ-B700A	1537.6103.02	<ul style="list-style-type: none"> required for mounting Rohde & Schwarz antennas at up to 5 inner faces (fixture layouts) not with R&S®CMQ-B701A/-B702A inner dimensions (W x H x D): 349 mm x 484 mm x 349 mm (13.7 in x 19.1 in x 13.7 in)
Quick release top cover 	R&S®CMQ-B703A R&S®CMQ-B703B R&S®CMQ-B703C	1540.4072.02 1540.4072.03 1540.4072.04	<ul style="list-style-type: none"> quick release for R&S®CMQ top cover levers instead of screws are used to close the top cover defined torque wrench possible by using a torque wrench with the lever R&S®CMQ-B703A for use with R&S®CMQ-B201 R&S®CMQ-B703B for use with R&S®CMQ-B221H R&S®CMQ-B703C for use with R&S®CMQ500
Inner support 1 	R&S®CMQ-B711A	1537.6226.02	<ul style="list-style-type: none"> support for device clamps to be mounted on antenna cradle recommended for R&D applications in combination with R&S®CMQ-B700A antenna cradle and device clamps (e.g. R&S®CMQ-B714A) not with R&S®CMQ-B701A/-B702A clamp mounting distance (outer screw distance): 188 mm (7.4 in) max. weight of clamp + device: 1.5 kg (3.3 lb)
Drawer support 1 	R&S®CMQ-B712A	1537.6310.02	<ul style="list-style-type: none"> support for device clamps to be mounted on drawer recommended for production applications in combination with R&S®CMQ-B700A antenna cradle and device clamp (e.g. R&S®CMQ-B714A) not with R&S®CMQ-B701A/-B702A clamp mounting distance <ul style="list-style-type: none"> outer screw distance: 284 mm (11.2 in) inner screw distance: 188 mm (7.4 in) support (W x H x D): 30 mm x 345 mm x 30 mm (1.2 in x 13.6 in x 1.2 in) maximum weight of clamp + device: 1 kg (2.2 lb), (weight distribution within 30 mm to pillar)

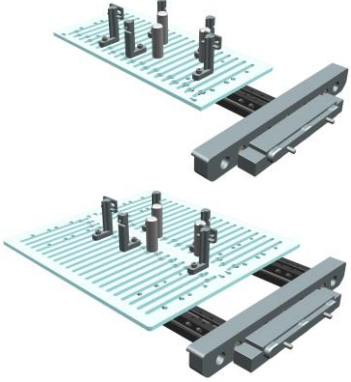
Designation	Type	Order No.	Description
Universal device clamp 1 (upright loading) 	R&S®CMQ-B714A	1537.6255.02	<ul style="list-style-type: none"> universal clamp recommended for smart devices with antenna arrays at 4 edges plus rear face in combination with support (e.g. R&S®CMQ-B711A / -B712A) maximum device width: 190 mm (7.5 in) maximum device thickness: 8 mm (0.3 in) maximum device weight: 1 kg (2.2 lb)
Universal device clamp 2 (horizontal loading), (illustrated with drawer support 1, R&S®CMQ-B712A) 	R&S®CMQ-B715A	1537.6261.02	<ul style="list-style-type: none"> universal clamp recommended for smart devices with antenna arrays at up to 3 edges plus rear face in combination with support (e.g. R&S®CMQ-B711A / -B712A) single-plate and dual-plate configuration possible maximum device size, single plate configuration: 120 mm x 12 mm x 270 mm (4.7 in x 0.5 in x 10.6 in) maximum device size, dual plate configuration: 280 mm x 12 mm x 270 mm (11 in x 0.5 in x 10.6 in) maximum device weight: 1 kg (2.2 lb)

RF setup

Depends on the FR2 device type and antenna location, any R&S®CMQ can be delivered with various preinstalled measurement antenna and RF connection kits up to 40 GHz.

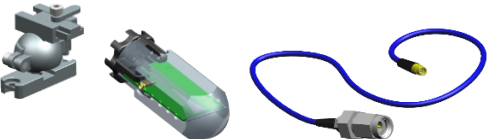
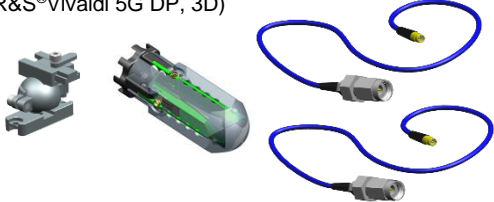

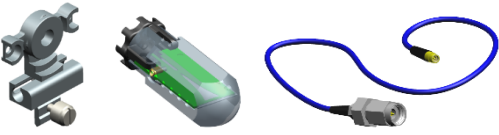
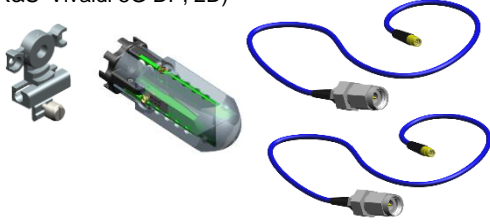
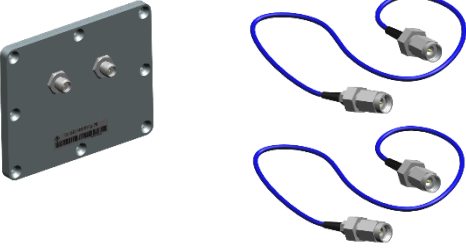
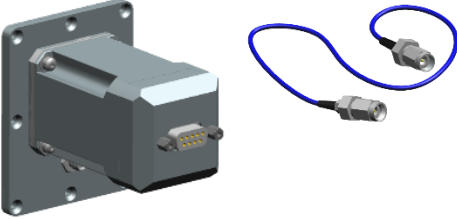
Designation	Type	Order No.	Description
Measurement antenna kits			
Measurement antenna kit 1 (R&S®Vivaldi 5G SP, 3D) 	R&S®CMQ-B721A R&S®CMQ-B721B	1537.6126.02 1537.6126.03	<ul style="list-style-type: none"> recommended for table layouts (single-face device testing) in combination with Rohde & Schwarz RF connection kits contains one single polarized measurement antenna with 3D fixture and one inner RF cable R&S®CMQ-B721A covers the frequency range up to 40 GHz R&S®CMQ-B721B covers the frequency range up to 50 GHz
Measurement antenna kit 2 (R&S®Vivaldi 5G DP, 3D) 	R&S®CMQ-B722A R&S®CMQ-B722B	1537.6132.02 1537.6132.03	<ul style="list-style-type: none"> recommended for table layouts (single-face device testing) in combination with Rohde & Schwarz RF connection kits contains one dual polarized measurement antenna with 3D fixture and two inner RF cables R&S®CMQ-B722A covers the frequency range up to 40 GHz R&S®CMQ-B722B covers the frequency range up to 50 GHz

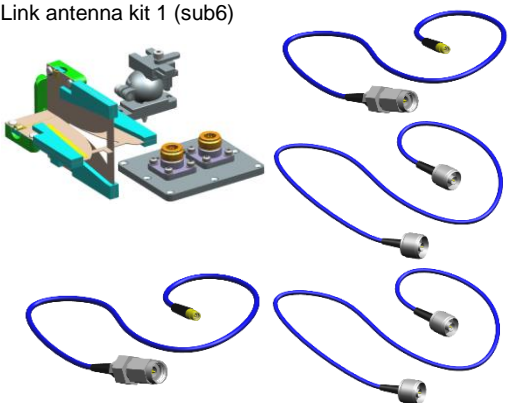
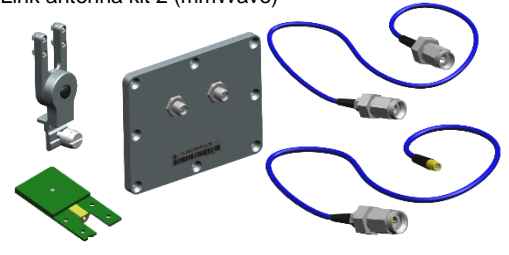

Designation	Type	Order No.	Description
Measurement antenna kit 3 (R&S®Vivaldi 5G SP, 2D) 	R&S®CMQ-B723A	1537.6149.02	<ul style="list-style-type: none"> recommended for fixture layouts (multi-face device testing) in combination with Rohde & Schwarz RF connection kits contains one single polarized measurement antenna with 2D fixture and one inner RF cable R&S®CMQ-B723A covers the frequency range up to 40 GHz R&S®CMQ-B723B covers the frequency range up to 50 GHz
	R&S®CMQ-B723B	1537.6149.03	
Measurement antenna kit 4 (R&S®Vivaldi 5G DP, 2D) 	R&S®CMQ-B724A	1537.6155.02	<ul style="list-style-type: none"> recommended for fixture layouts (multi-face device testing) in combination with Rohde & Schwarz RF connection kits contains one dual polarized measurement antenna with 2D fixture and two inner RF cables R&S®CMQ-B724A covers the frequency range up to 40 GHz R&S®CMQ-B724B covers the frequency range up to 50 GHz
	R&S®CMQ-B724B	1537.6155.03	
RF connection kits			
RF connection kit 2 (2 × mmWave paths) 	R&S®CMQ-B742A	1537.6190.02	<ul style="list-style-type: none"> recommended in combination with Rohde & Schwarz dual polarized measurement antenna kits (e.g. R&S®CMQ-722A/-B724A) contains one Rohde & Schwarz feedthrough and two external RF cables to connect Rohde & Schwarz remote radio heads R&S®CMQ-B742A covers the frequency range up to 40 GHz R&S®CMQ-B742B covers the frequency range up to 50 GHz
	R&S®CMQ-B742B	1537.6190.03	
RF connection kit 4 (SP6T) 	R&S®CMQ-B744A	1537.6284.02	<ul style="list-style-type: none"> recommended in combination with measurement antenna kits (e.g. R&S®CMQ-B722A/-B724A) contains one feedthrough module with integrated SP6T RF switch (6 × inner mmWave paths, coaxial) and one external 200 mm RF cable to connect Rohde & Schwarz remote radio heads can be controlled via remote interface of R&S®CMQ R&S®CMQ-B744A covers the frequency range up to 40 GHz R&S®CMQ-B744B covers the frequency range up to 50 GHz
	R&S®CMQ-B744B	1537.6284.03	

Designation	Type	Order No.	Description
Link antenna kit Link antenna kit 1 (sub6) 	R&S®CMQ-B751A	1537.6378.02	<ul style="list-style-type: none"> recommended for signaling use cases in addition to measurement antenna kits comes with dual polarized link antenna (MIMO 2x2), 3D antenna fixture, two internal RF cables, feedthrough and two external RF cables
Link antenna kit 2 (mmWave) 	R&S®CMQ-B752A	1537.6290.02	<ul style="list-style-type: none"> recommended for signaling use cases in addition to measurement antenna kits comes with single polarized link antenna, 2D antenna fixture, one internal RF cable, feedthrough and one external RF cable to connect Rohde & Schwarz remote radio heads

Extras

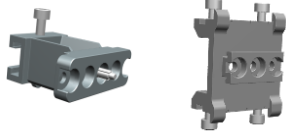
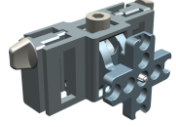
Listed products will be delivered separately and must be installed on-site.

Designation	Type	Order No.	Description
3D fixture for Rohde & Schwarz power sensors 	R&S®CMQ-B716A	1537.6332.02	<ul style="list-style-type: none"> in combination with R&S®NRPM-A90x antenna modules of R&S®NRPM OTA power measurement solution single rail mounting adjustments: <ul style="list-style-type: none"> polarization: 0° to 360° continuous rotation tilt: -22.5° to 0° to +22.5° continuous rotation
2D fixture for Rohde & Schwarz power sensors 	R&S®CMQ-B717A	1537.6303.02	<ul style="list-style-type: none"> in combination with R&S®NRPM-A90x antenna modules of R&S®NRPM OTA power measurement solution single rail mounting adjustment: polarization: 0° or 45° or 90°
2D fixture for Rohde & Schwarz antennas 	R&S®CMQ-B717B	1537.6303.03	<ul style="list-style-type: none"> in combination with R&S®TS-F24-Vx Vivaldi antennas fixtures for single and dual rail mounting no adjustment always orthogonal from mounting rail
2D fixture flexible for Rohde & Schwarz antennas 	R&S®CMQ-B717C	1537.6303.04	<ul style="list-style-type: none"> in combination with R&S®TS-F24-Vx Vivaldi antennas dual rail mounting adjustment: tilt: -45° to 45°

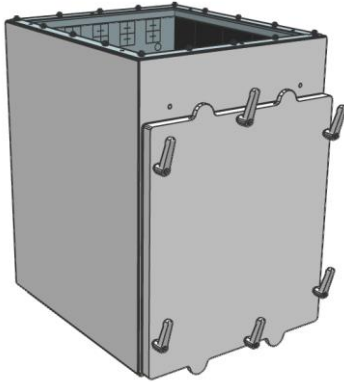
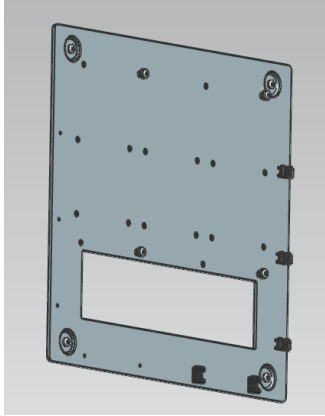
<p>Drawer fixture 2 (horizontal loading)</p> 	R&S®CMQ-B719A	1537.6355.02	<ul style="list-style-type: none"> • customized fixture for smart devices • to be mounted on drawer • recommended in combination with R&S®CMQ-B700A antenna cradle • not with R&S®CMQ-B701A/-B702A
<p>Laser kit 1 for R&S®Vivaldi 5G adjustment</p> 	R&S®CMQ-Z780A	1537.6361.02	<ul style="list-style-type: none"> • for adjustment of measurement antenna R&S®Vivaldi 5G • external USB power supply required
<p>Laser kit 2 for R&S®TS-F24-V3 adjustment</p> 	R&S®CMQ-Z780B	1537.6361.03	<ul style="list-style-type: none"> • for adjustment of measurement antenna R&S®TS-F24-V3 crosspolarized Vivaldi antenna • external USB power supply required • recommended for UWB setups
<p>Height extension</p> 	R&S®CMQ-Z784A	1540.4008.02	<ul style="list-style-type: none"> • extending the possible measurement distance in the R&S®CMQ by 600 mm • quick access to antenna setup from the front • R&S®CMQ-Z784A for use with R&S®CMQ-B201 • R&S®CMQ-Z784B for use with R&S®CMQ-B221H • R&S®CMQ-Z784C for use with R&S®CMQ500
	R&S®CMQ-Z784B	1540.4008.03	
	R&S®CMQ-Z784C	1540.4008.04	
<p>Holding plate front</p> 	R&S®CMQ-Z787A	1540.4095.02	<ul style="list-style-type: none"> • mounting plate for the front door of the R&S®CMQ • provides an interface to fix Rohde & Schwarz remote radio heads on it

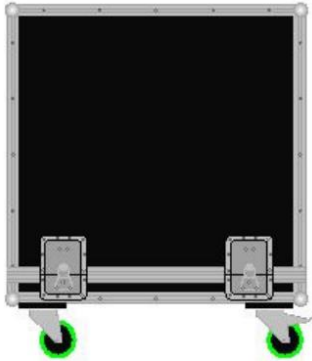
<p>Transport case</p> 	<p>R&S®CMQ -ZG785A</p>	<p>1537.6161.02</p>	<p>transport case for R&S®CMQ with the outer dimensions (W x H x D): 754 mm x 542 mm x 760 mm (29.7 in x 21.3 in x 30.0 in)</p>
---	--------------------------------	---------------------	---

For available feedthroughs see separate document.

Glossary

Term	Explanation
Antenna cradle	mechanical item to hold measurement antennas; also used to hold devices under test (inner table or fixture layouts); must be ordered separately for fixture layouts
Basic assembly	welded mainframe, mandatory for each R&S®CMQ
Basic configuration	R&S®CMQ configuration step to select open-close mechanism and basic assembly
Data e2e	data end-to-end testing
DP	dual polarized
Drawer fixture	fixture that is mounted on front drawer
Drawer support	support that is mounted on front drawer
Drawer table layout	R&S®CMQ OTA layout containing antenna cradle and table; table is mounted on front drawer; recommended for single-face devices
Fixture	mechanical item to hold multi-face devices; might consist of support and clamp
Fixture layout	R&S®CMQ OTA layout for multi-face devices; measurement antennas mounted on up to 5 inner faces (left, right, back, ceiling, floor); multiple test directions
FR1	3GPP designation for 5G frequencies in the classical mobile communications range (normally below 6 GHz)
FR2	3GPP designation for 5G frequencies in the mmWave range (approx. 20 GHz to 50 GHz)
Horizontal loading	loading orientation for smart devices with antennas on up to 3 edges
Inner support	support that is mounted on inside of the R&S®CMQ
Inner table layout	R&S®CMQ OTA layout containing antenna cradle and table; table is mounted on inside of the R&S®CMQ; recommended for single-face devices
Link antenna kit	R&S®CMQ kit for signaling testing or DUT control; consists of link antenna, antenna fixture, inner RF cables, feedthrough and outer RF cables; in most cases required additionally to Rohde & Schwarz measurement antenna kits
Measurement antenna kit	R&S®CMQ kit for 5G FR2 RF parametric and signaling testing; consists of measurement antenna, antenna fixture and inner RF cables; always in combination with R&S®CMQ RF connection kit
Measurement distance	distance between device surface and tip of measurement antenna
mmWave	millimeterwave
Multi-face device	5G FR2 device with antennas on several faces
Non-signaling mode	RF parametric test environment with an analyzer and generator; DUT is operated in test mode
OTA	over the air (radiated test environment)
OTA layout	R&S®CMQ configuration step for device alignment and selection of single-face or multi-face test environment (table or fixture layout)
RF connection kit	R&S®CMQ kit for 5G FR2 testing; consists of feedthrough/switch and outer cables; always in combination with R&S®CMQ measurement antenna kits
R&S®CMP200	Rohde & Schwarz radio communication tester for 5G IF parametric testing; in combination with remote radio head (RRH) also for 5G FR2 RF parametric testing (non-signaling mode)
R&S®CMPHEAD30	Rohde & Schwarz RRH; in combination with R&S®CMP200 for 5G FR2 RF parametric testing
R&S®CMQ200 + R&S®CMQ-B201C	Rohde & Schwarz compact shielding solution; frequency range: 20 GHz to 77 GHz; fixed geometry; in combination with R&S®CMP200/RRH for RF parametric testing of 5G FR2 devices
R&S®CMQ200 + R&S®CMQ-B221H	Rohde & Schwarz compact shielding solution; frequency range: 0.3 GHz to 14 GHz; fixed geometry; in combination with R&S®CMP200 for RF parametric testing of UWB devices
R&S®CMQ500	Rohde & Schwarz compact shielding solution; frequency range: 0.7 GHz to 77 GHz; fixed geometry; in combination with R&S®CMX500/RRH and R&S®CMW500 for signaling testing of 5G FR1 and FR2 devices
R&S®CMsquares	Rohde & Schwarz unified user interface for all applications (signaling and non-signaling)
R&S®CMXHEAD30	Rohde & Schwarz RRH; in combination with R&S®CMX500 for 5G FR2 signaling testing
R&S®Vivaldi 5G	Rohde & Schwarz measurement antenna for 5G FR2 RF parametric testing (part of R&S®CMQ measurement antenna kits)
Signaling mode	network-like reference test environment based on a real-time network emulator (also called signaling tester; also contains an RF analyzer)
Single-face device	5G FR2 device with antennas on one single face
SP	single polarized
SP6T	single pole, 6 throw (RF switch with a single input and 6 output paths)
Support	mechanical item to position multi-face devices; device clamp required additionally
Table	mechanical item to position single-face devices
Table layout	R&S®CMQ OTA layout for single-face devices; vertical test direction; measurement antennas mounted on ceiling of R&S®CMQ
Universal device clamp	mechanical item to hold a smart device of a certain size range; support required additionally
Upright loading	recommended loading orientation for smart devices with antennas on up to four edges
2D fixture	mechanical item to hold R&S®NRPM power sensor antennas in cradle; stepwise adjustment of polarization layer (0°, 45°, 90°) possible
3D fixture	mechanical item to hold R&S®NRPM power sensor antennas in cradle; flexible adjustment of polarization layer and tilt possible

Service at Rohde & Schwarz
You're in great hands

- ▶ Worldwide
- ▶ Local and personalized
- ▶ Customized and flexible
- ▶ Uncompromising quality
- ▶ Long-term dependability

Rohde & Schwarz

The Rohde&Schwarz technology group is among the trail-blazers when it comes to paving the way for a safer and connected world with its leading solutions in test & measurement, technology systems and networks & cybersecurity. Founded 90 years ago, the group is a reliable partner for industry and government customers around the globe. The independent company is headquartered in Munich, Germany and has an extensive sales and service network with locations in more than 70 countries.

www.rohde-schwarz.com

Sustainable product design

- ▶ Environmental compatibility and eco-footprint
- ▶ Energy efficiency and low emissions
- ▶ Longevity and optimized total cost of ownership

Certified Quality Management

ISO 9001

Certified Environmental Management

ISO 14001

Rohde & Schwarz training

www.training.rohde-schwarz.com

Rohde & Schwarz customer support

www.rohde-schwarz.com/support

