

R&S® FE170-Zxx ACCESSORIES

Specifications

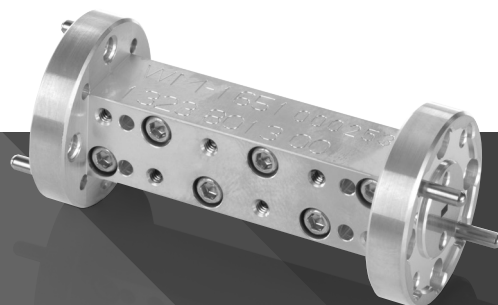

Specifications
Version 04.00

ROHDE & SCHWARZ

Make ideas real



CONTENTS

Definitions	3
Specifications.....	4
Bandpass filters	4
<i>Electrical specifications</i>	4
<i>Measured insertion loss and return loss over frequency</i>	6
R&S®FE170-Z14/-Z15/-Z16/-Z17	19
Outline drawing of R&S®FE170-Z01	19
Inputs and outputs.....	20
General data	20
R&S®FE170-Z20 WR6.5 waveguide-to-waveguide adapter	21
<i>Electrical specifications</i>	21
<i>Measured insertion loss and return loss over frequency</i>	21
Outline drawing	21
Inputs and outputs.....	22
General data	22
R&S®FE170-Z50 full D band medium power amplifier.....	23
Electrical specifications	23
<i>Measured gain and return loss over frequency</i>	24
<i>Measured saturation power over frequency</i>	24
Outline drawing	25
Inputs and outputs.....	25
General data	25
Ordering information	26
Recommended extras.....	26
Service options	26

Definitions

General

Product data applies under the following conditions:

- Three hours of storage at ambient temperature followed by 30 minutes of warm-up operation
- Specified environmental conditions met
- Recommended calibration interval adhered to
- All internal automatic adjustments performed, if applicable

Specifications with limits

Represent warranted product performance by means of a range of values for the specified parameter. These specifications are marked with limiting symbols such as $<$, \leq , $>$, \geq , \pm or descriptions such as maximum, limit of, minimum. Compliance is ensured by testing or is derived from the design. Test limits are narrowed by guard bands to take into account measurement uncertainties, drift and aging, if applicable.

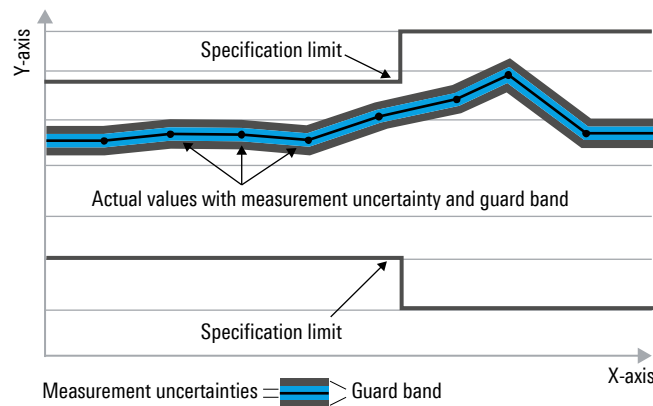

Non-traceable specifications with limits (n. trc.)

Represent product performance that is specified and tested as described under “Specifications with limits” above. However, product performance in this case cannot be warranted due to the lack of measuring equipment traceable to national metrology standards. In this case, measurements are referenced to standards used in the Rohde & Schwarz laboratories.

Specifications without limits

Represent warranted product performance for the specified parameter. These specifications are not specially marked and represent values with no or negligible deviations from the given value, e.g. dimensions or resolution of a setting parameter. Compliance is ensured by design.

Typical data (typ.)

Characterizes product performance by means of representative information for the given parameter. When marked with $<$, $>$ or as a range, it represents the performance met by approximately 80 % of the instruments at production time. Otherwise, it represents the mean value.

Nominal values (nom.)

Characterize product performance by means of a representative value for the given parameter, e.g. nominal impedance. In contrast to typical data, a statistical evaluation does not take place and the parameter is not tested during production.

Measured values (meas.)

Characterize expected product performance by means of measurement results gained from individual samples.

Uncertainties

Represent limits of measurement uncertainty for a given measurand. Uncertainty is defined with a coverage factor of 2 and has been calculated in line with the rules of the Guide to the Expression of Uncertainty in Measurement (GUM), taking into account environmental conditions, aging, wear and tear.

Device settings and GUI parameters are designated with the format “parameter: value”.

Non-traceable specifications with limits, typical data as well as nominal and measured values are not warranted by Rohde & Schwarz.

In line with the 3GPP standard, chip rates are specified in million chips per second (Mcps), whereas bit rates and symbol rates are specified in billion bit per second (Gbps), million bit per second (Mbps), thousand bit per second (kbps), million symbols per second (Msps) or thousand symbols per second (ksps), and sample rates are specified in million samples per second (Msample/s). Gbps, Mcps, Mbps, Msps, kbps, ksps and Msample/s are not SI units.

Specifications

Bandpass filters

The bandpass filters are available for the frequency bands:

- 110 GHz to 136 GHz (R&S®FE170-Z01)
- 126 GHz to 153 GHz (R&S®FE170-Z02)
- 143 GHz to 170 GHz (R&S®FE170-Z03)
- 160 GHz to 175 GHz (R&S®FE170-Z04)
- 110 GHz to 126 GHz (R&S®FE170-Z10)
- 116 GHz to 132 GHz (R&S®FE170-Z11)
- 122 GHz to 138 GHz (R&S®FE170-Z12)
- 128 GHz to 145 GHz (R&S®FE170-Z13)
- 135 GHz to 151 GHz (R&S®FE170-Z14)
- 141 GHz to 157 GHz (R&S®FE170-Z15)
- 147 GHz to 163 GHz (R&S®FE170-Z16)
- 153 GHz to 170 GHz (R&S®FE170-Z17)

The filter includes an internal memory that contains identification information and calibration data. Rohde & Schwarz frontend units readout the stored data and will use them to correct for insertion loss, thus the level at the user interface is calibrated, even for wideband modulation.

Electrical specifications

Frequency range		
R&S®FE170-Z01		110 GHz to 136 GHz
R&S®FE170-Z02		126 GHz to 153 GHz
R&S®FE170-Z03		143 GHz to 170 GHz
R&S®FE170-Z04		160 GHz to 175 GHz
R&S®FE170-Z10		110 GHz to 126 GHz
R&S®FE170-Z11		116 GHz to 132 GHz
R&S®FE170-Z12		122 GHz to 138 GHz
R&S®FE170-Z13		128 GHz to 145 GHz
R&S®FE170-Z14		135 GHz to 151 GHz
R&S®FE170-Z15		141 GHz to 157 GHz
R&S®FE170-Z16		147 GHz to 163 GHz
R&S®FE170-Z17		153 GHz to 170 GHz
Insertion loss		
R&S®FE170-Z01	110 GHz ≤ f ≤ 136 GHz	< 1.65 dB, < 1.15 dB (meas.)
R&S®FE170-Z02	126 GHz ≤ f ≤ 153 GHz	< 1.85 dB, < 1.15 dB (meas.)
R&S®FE170-Z03	143 GHz ≤ f ≤ 170 GHz	< 2.25 dB, < 1.3 dB (meas.)
R&S®FE170-Z04	160 GHz ≤ f ≤ 170 GHz	< 2.55 dB, < 1.5 dB (meas.)
R&S®FE170-Z10	110 GHz ≤ f ≤ 126 GHz	< 2.15 dB, < 1.2 dB (meas.)
R&S®FE170-Z11	116 GHz ≤ f ≤ 132 GHz	< 2.15 dB, < 1.2 dB (meas.)
R&S®FE170-Z12	122 GHz ≤ f ≤ 138 GHz	< 2.35 dB, < 1.6 dB (meas.)
R&S®FE170-Z13	128 GHz ≤ f ≤ 145 GHz	< 2.35 dB, < 1.7 dB (meas.)
R&S®FE170-Z14	135 GHz ≤ f ≤ 151 GHz	< 2.05 dB, < 1.3 dB (meas.)
R&S®FE170-Z15	141 GHz ≤ f ≤ 157 GHz	< 2.05 dB, < 1.3 dB (meas.)
R&S®FE170-Z16	147 GHz ≤ f ≤ 163 GHz	< 2.65 dB, < 1.7 dB (meas.)
R&S®FE170-Z17	153 GHz ≤ f ≤ 170 GHz	< 2.85 dB, < 1.7 dB (meas.)
Return loss		
R&S®FE170-Z01	110 GHz ≤ f ≤ 136 GHz	> 13 dB, > 16 dB (meas.)
R&S®FE170-Z02	126 GHz ≤ f ≤ 153 GHz	> 18 dB, > 23 dB (meas.)
R&S®FE170-Z03	143 GHz ≤ f ≤ 170 GHz	> 17 dB, > 22 dB (meas.)
R&S®FE170-Z04	160 GHz ≤ f ≤ 170 GHz	> 16 dB, > 22 dB (meas.)
R&S®FE170-Z10	110 GHz ≤ f ≤ 126 GHz	> 16 dB, > 19 dB (meas.)
R&S®FE170-Z11	116 GHz ≤ f ≤ 132 GHz	> 16 dB, > 21 dB (meas.)
R&S®FE170-Z12	122 GHz ≤ f ≤ 138 GHz	> 16 dB, > 19 dB (meas.)
R&S®FE170-Z13	128 GHz ≤ f ≤ 145 GHz	> 18 dB, > 24 dB (meas.)
R&S®FE170-Z14	135 GHz ≤ f ≤ 151 GHz	> 16 dB, > 20 dB (meas.)
R&S®FE170-Z15	141 GHz ≤ f ≤ 157 GHz	> 16 dB, > 21 dB (meas.)
R&S®FE170-Z16	147 GHz ≤ f ≤ 163 GHz	> 16 dB, > 23 dB (meas.)
R&S®FE170-Z17	153 GHz ≤ f ≤ 170 GHz	> 16 dB, > 23 dB (meas.)

Stopband attenuation		
R&S®FE170-Z01	141 GHz ≤ f ≤ 170 GHz	> 44 dB, > 54 dB (meas.)
R&S®FE170-Z02	110 GHz ≤ f ≤ 121 GHz, 158 GHz ≤ f ≤ 170 GHz	> 54 dB, > 75 dB (meas.), > 42 dB, > 51 dB (meas.)
R&S®FE170-Z03	110 GHz ≤ f ≤ 138 GHz	> 44 dB, > 54 dB (meas.)
R&S®FE170-Z04	110 GHz ≤ f ≤ 155 GHz	> 54 dB, > 80 dB (meas.)
R&S®FE170-Z10	131 GHz ≤ f ≤ 170 GHz	> 47 dB, > 70 dB (meas.)
R&S®FE170-Z11	110 GHz ≤ f ≤ 112 GHz, 137 GHz ≤ f ≤ 170 GHz	> 49 dB, > 64 dB (meas.), > 49 dB, > 60 dB (meas.)
R&S®FE170-Z12	110 GHz ≤ f ≤ 117 GHz, 143 GHz ≤ f ≤ 170 GHz	> 54 dB, > 64 dB (meas.), > 49 dB, > 60 dB (meas.)
R&S®FE170-Z13	110 GHz ≤ f ≤ 123 GHz, 150 GHz ≤ f ≤ 170 GHz	> 54 dB, > 65 dB (meas.), > 54 dB, > 64 dB (meas.)
R&S®FE170-Z14	110 GHz ≤ f ≤ 130 GHz, 156 GHz ≤ f ≤ 170 GHz	> 54 dB, > 69 dB (meas.), > 54 dB, > 70 dB (meas.)
R&S®FE170-Z15	110 GHz ≤ f ≤ 136 GHz, 162 GHz ≤ f ≤ 170 GHz	> 59 dB, > 70 dB (meas.), > 57 dB, > 70 dB (meas.)
R&S®FE170-Z16	110 GHz ≤ f ≤ 142 GHz, 168 GHz ≤ f ≤ 170 GHz	> 59 dB, > 70 dB (meas.), > 57 dB, > 70 dB (meas.)
R&S®FE170-Z17	110 GHz ≤ f ≤ 148 GHz, 175 GHz	> 60 dB, > 77 dB (meas.), > 68 dB (meas.)
Passband ripple		
R&S®FE170-Z01	110 GHz ≤ f ≤ 136 GHz	< 0.1 dB (meas.)
R&S®FE170-Z02	126 GHz ≤ f ≤ 153 GHz	< 0.05 dB (meas.)
R&S®FE170-Z03	143 GHz ≤ f ≤ 170 GHz	< 0.05 dB (meas.)
R&S®FE170-Z04	160 GHz ≤ f ≤ 170 GHz	< 0.05 dB (meas.)
R&S®FE170-Z10	110 GHz ≤ f ≤ 126 GHz	< 0.06 dB (meas.)
R&S®FE170-Z11	116 GHz ≤ f ≤ 132 GHz	< 0.05 dB (meas.)
R&S®FE170-Z12	122 GHz ≤ f ≤ 138 GHz	< 0.05 dB (meas.)
R&S®FE170-Z13	128 GHz ≤ f ≤ 145 GHz	< 0.06 dB (meas.)
R&S®FE170-Z14	135 GHz ≤ f ≤ 151 GHz	< 0.07 dB (meas.)
R&S®FE170-Z15	141 GHz ≤ f ≤ 157 GHz	< 0.03 dB (meas.)
R&S®FE170-Z16	147 GHz ≤ f ≤ 163 GHz	< 0.07 dB (meas.)
R&S®FE170-Z17	153 GHz ≤ f ≤ 170 GHz	< 0.03 dB (meas.)

Measured insertion loss and return loss over frequency

R&S®FE170-Z01

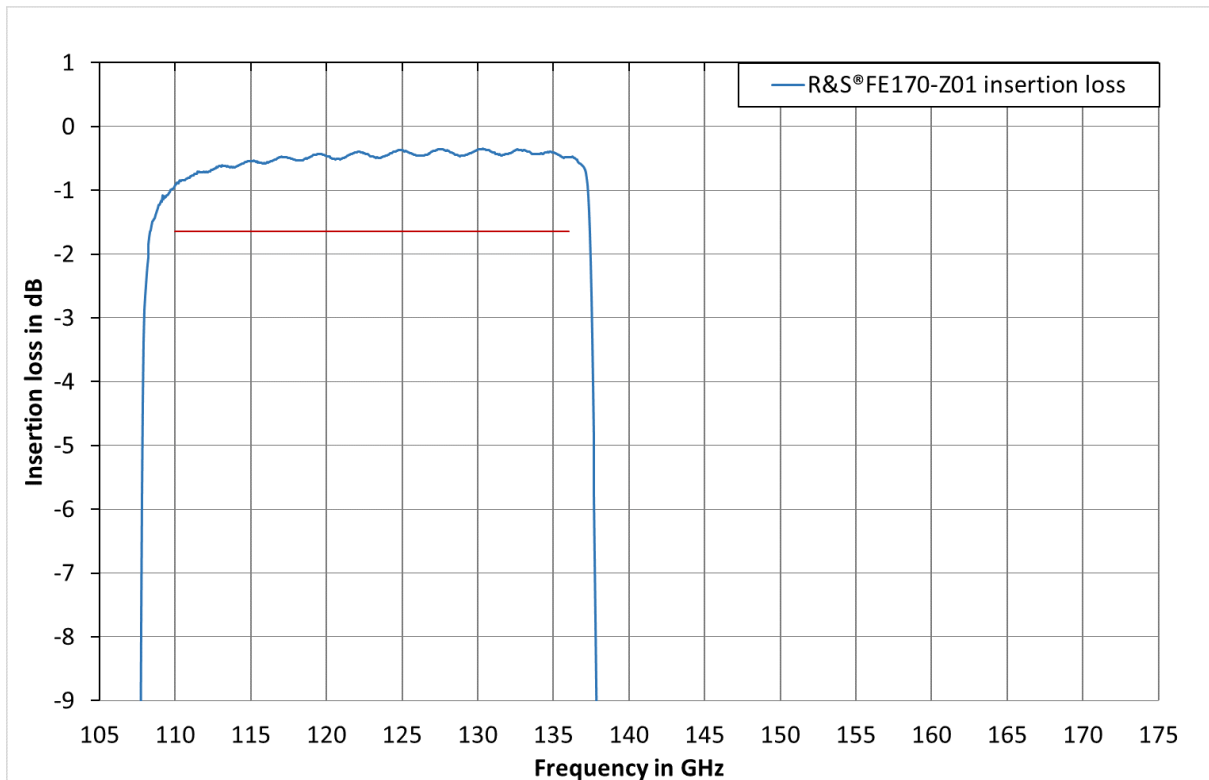
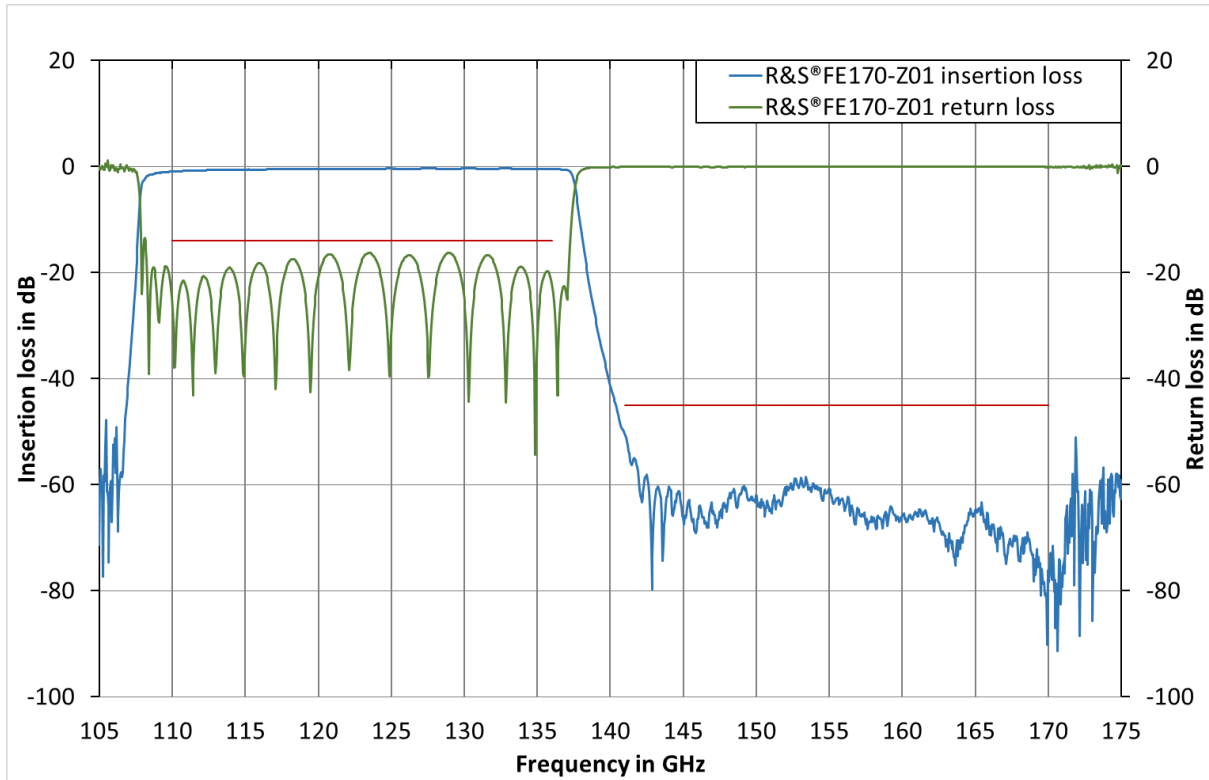

R&S®FE170-Z02

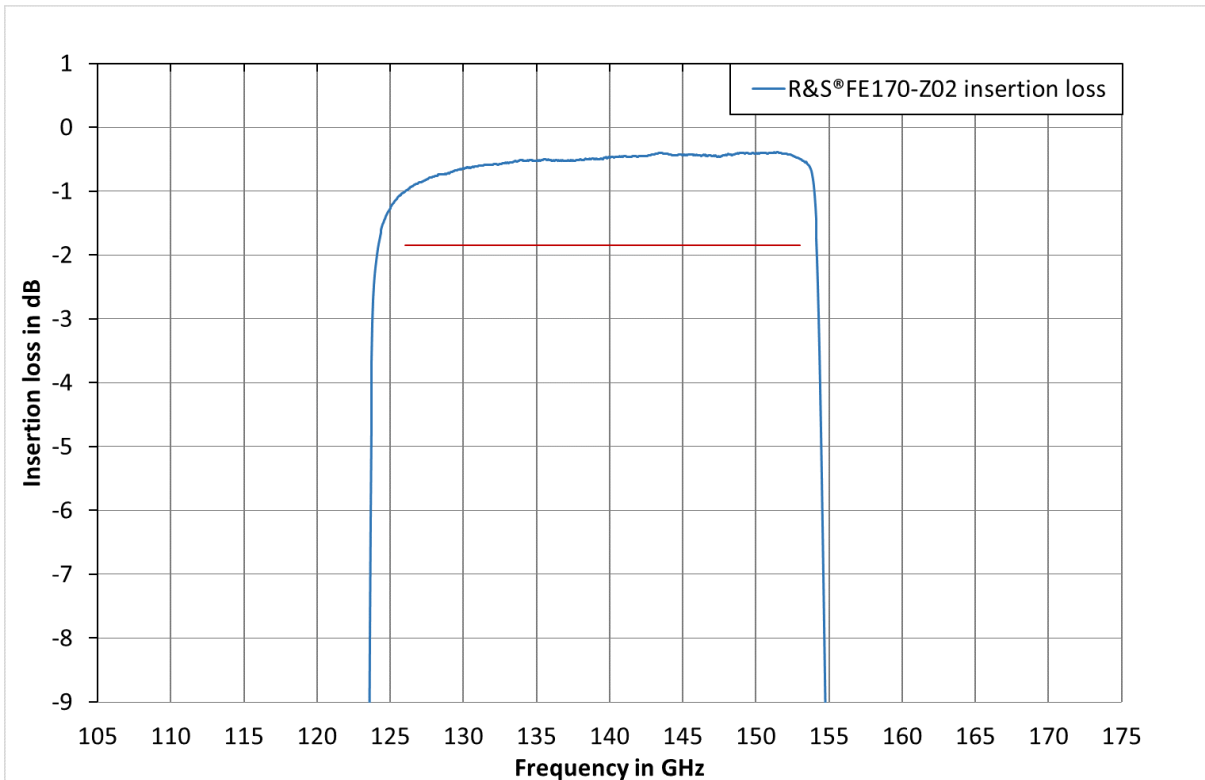
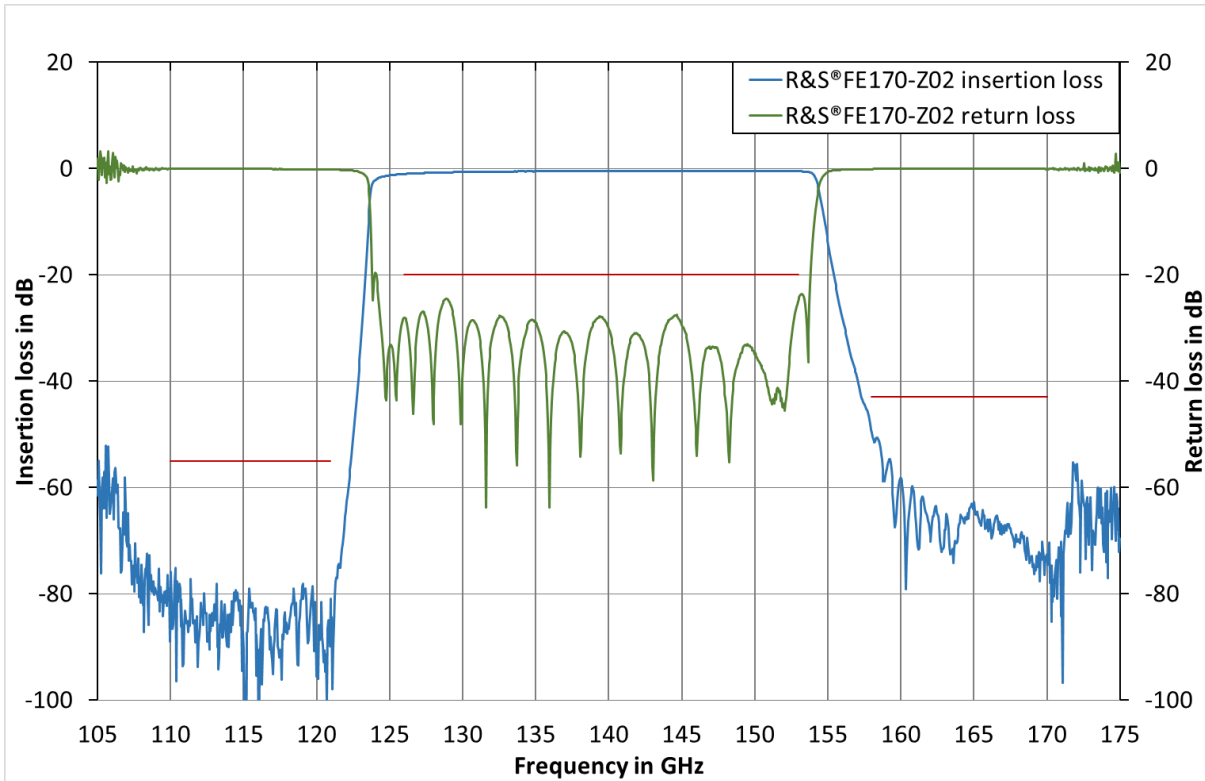

R&S®FE170-Z03

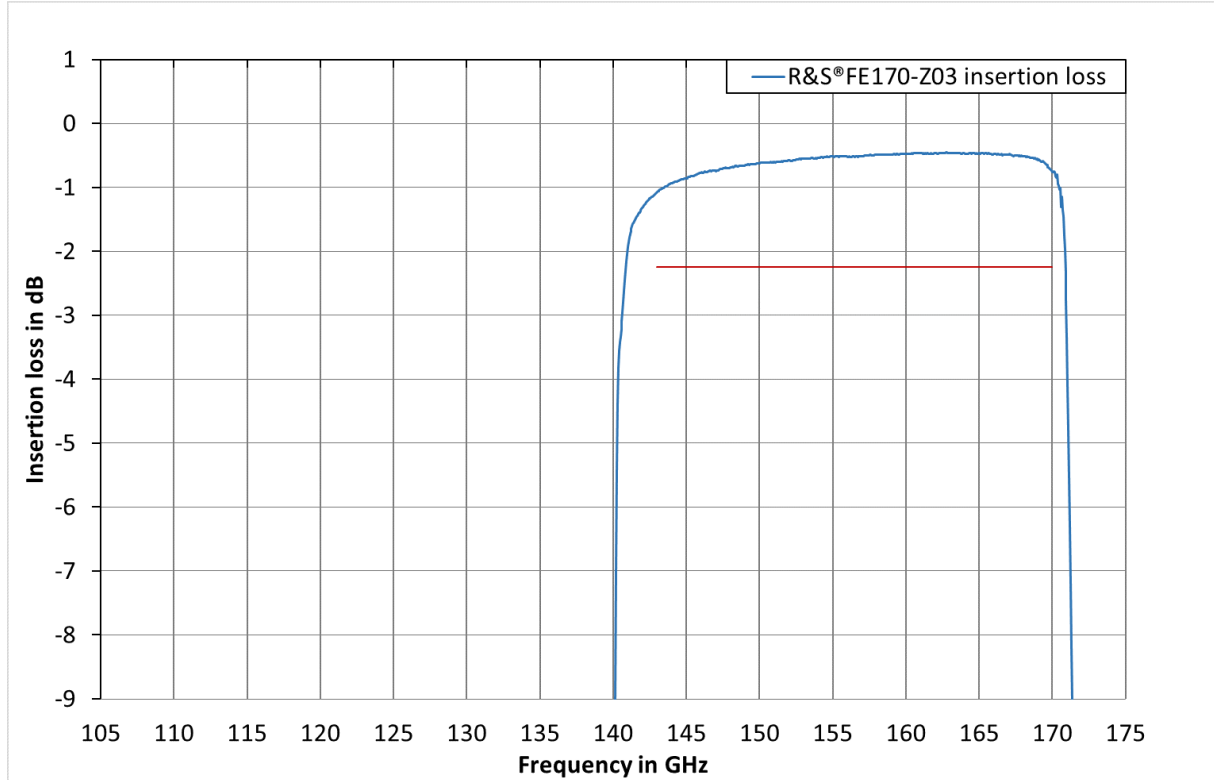
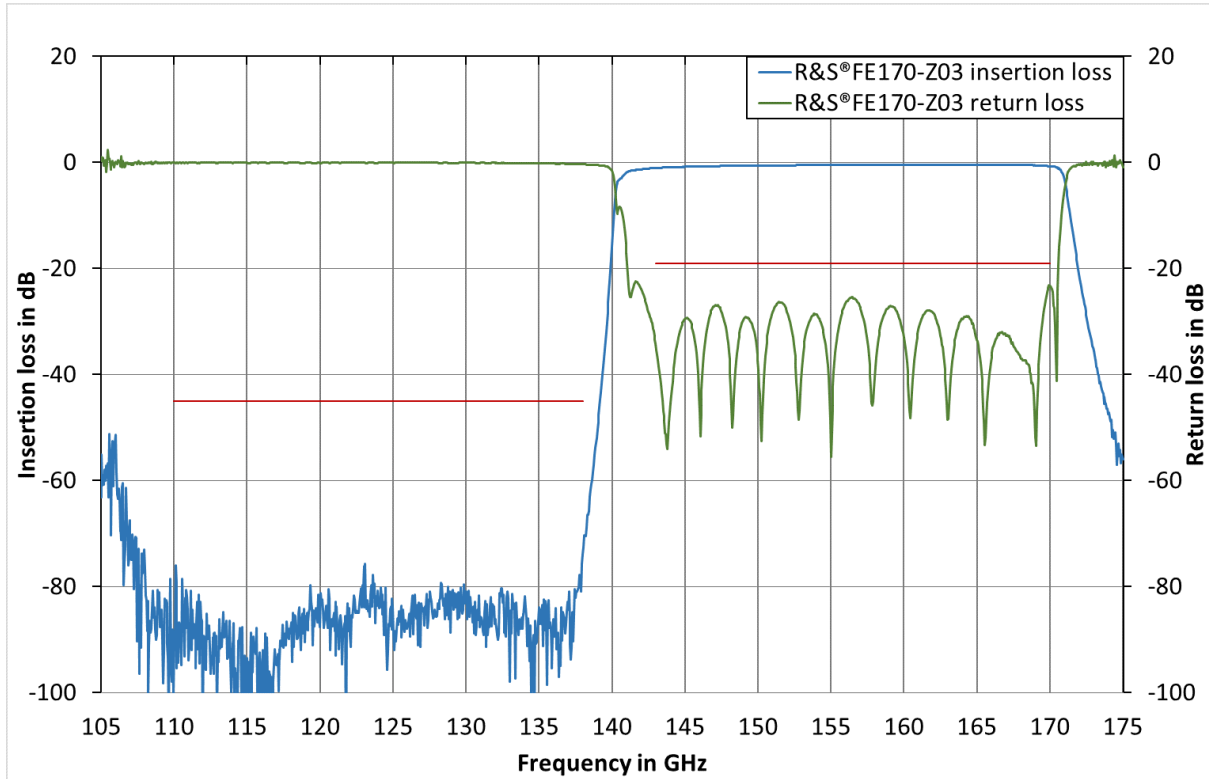

R&S®FE170-Z04

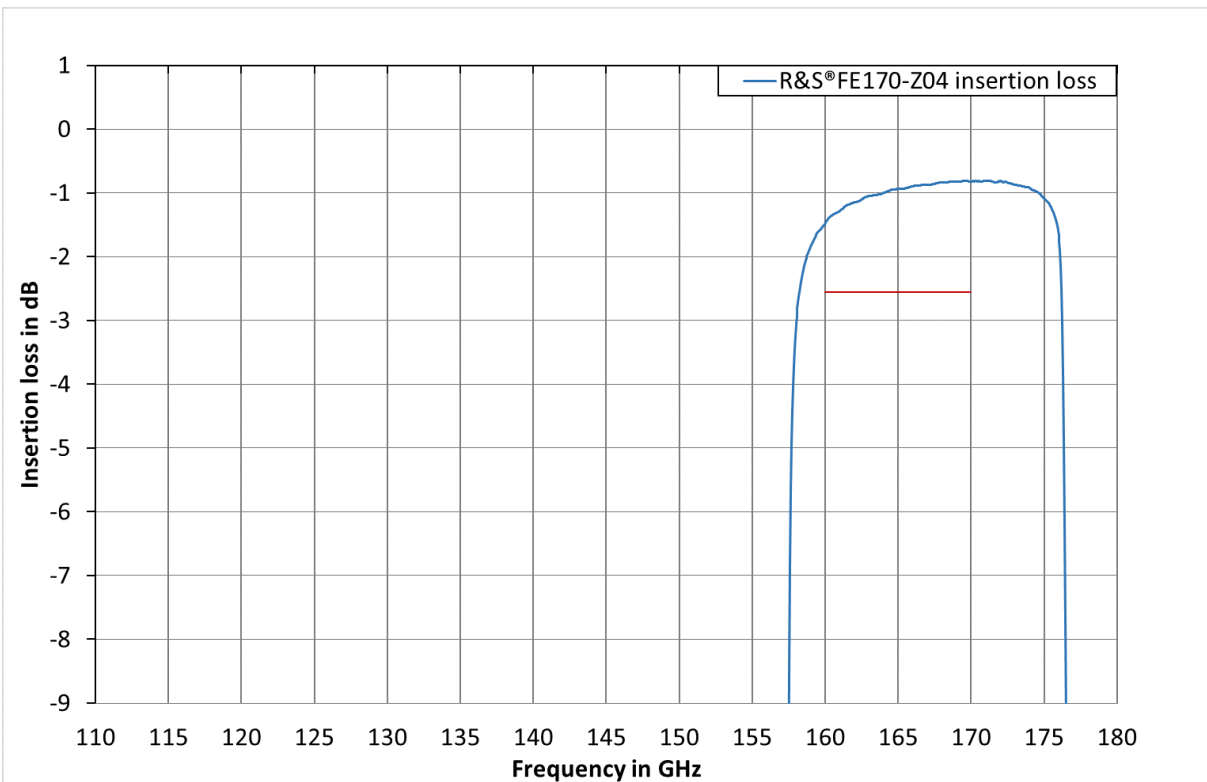
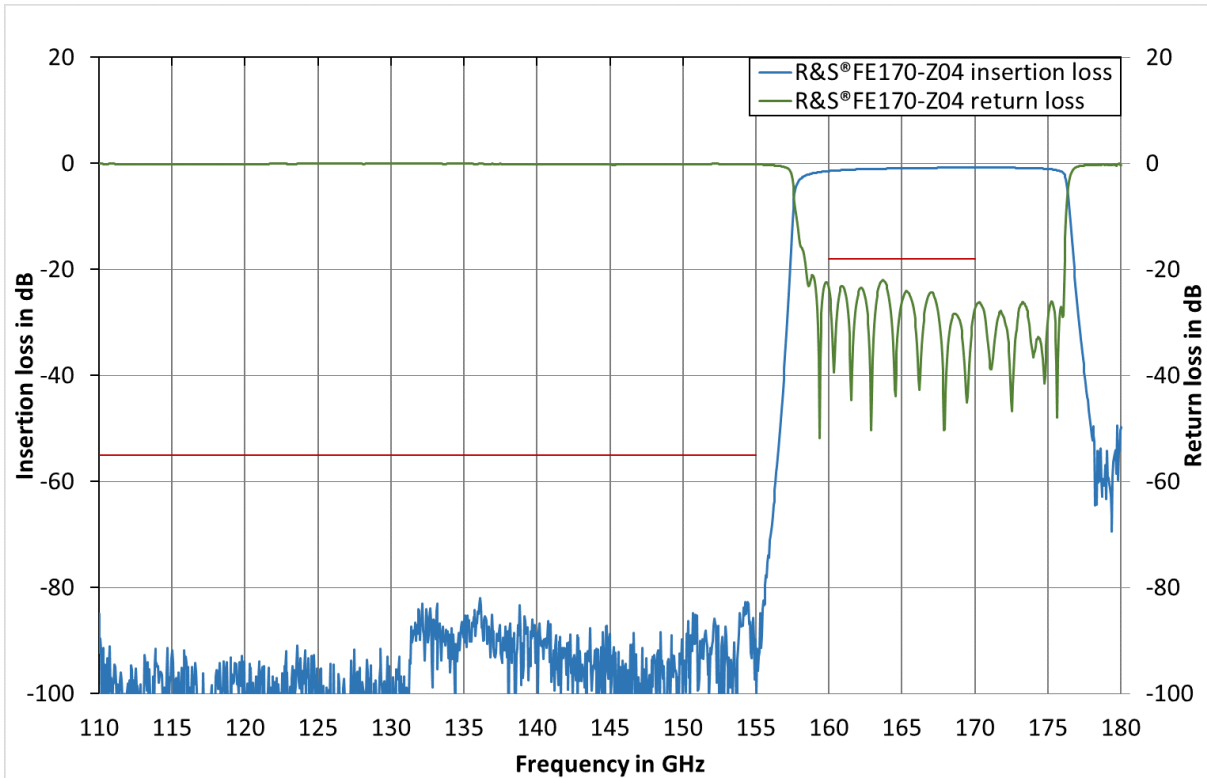

R&S®FE170-Z10

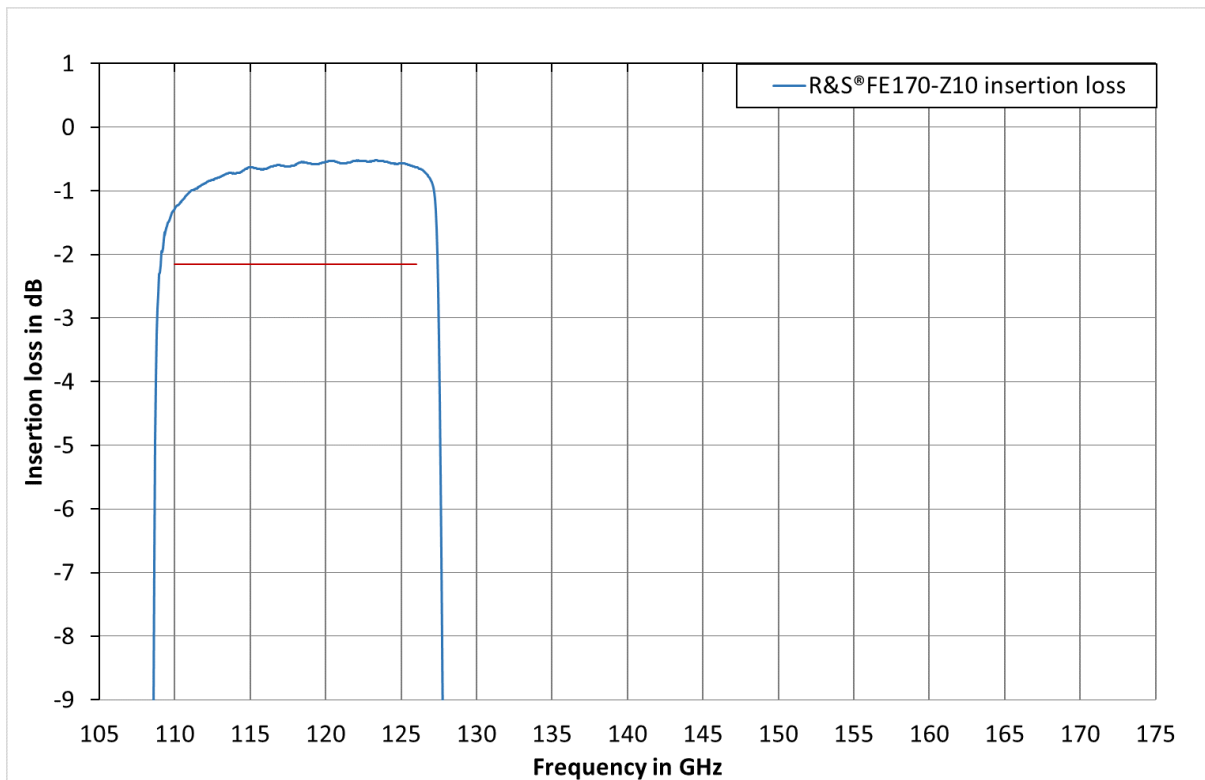
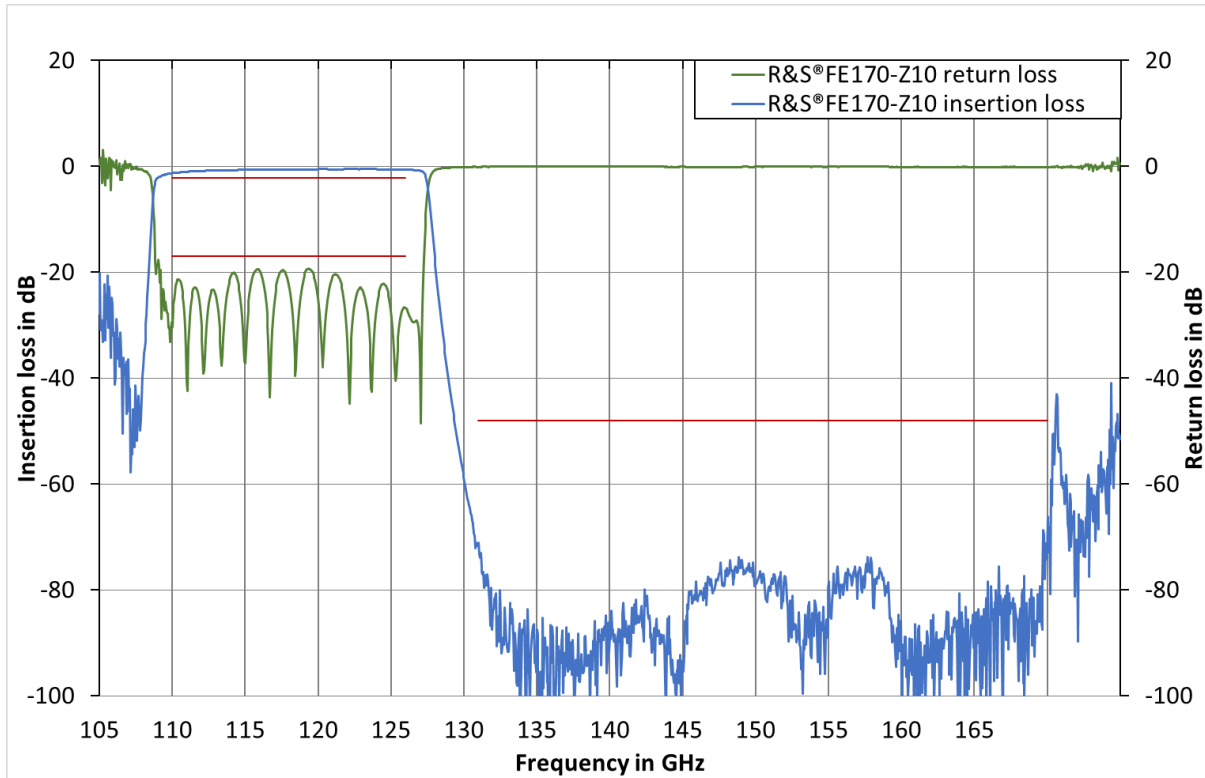

R&S®FE170-Z11

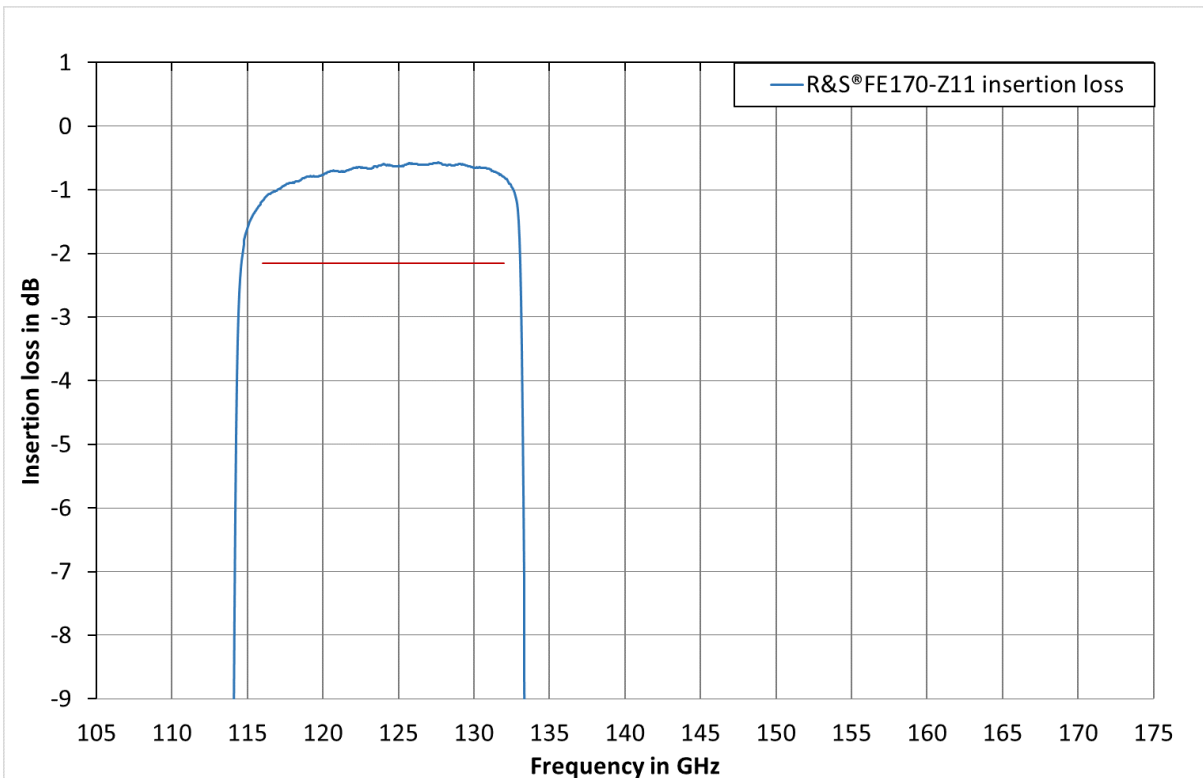
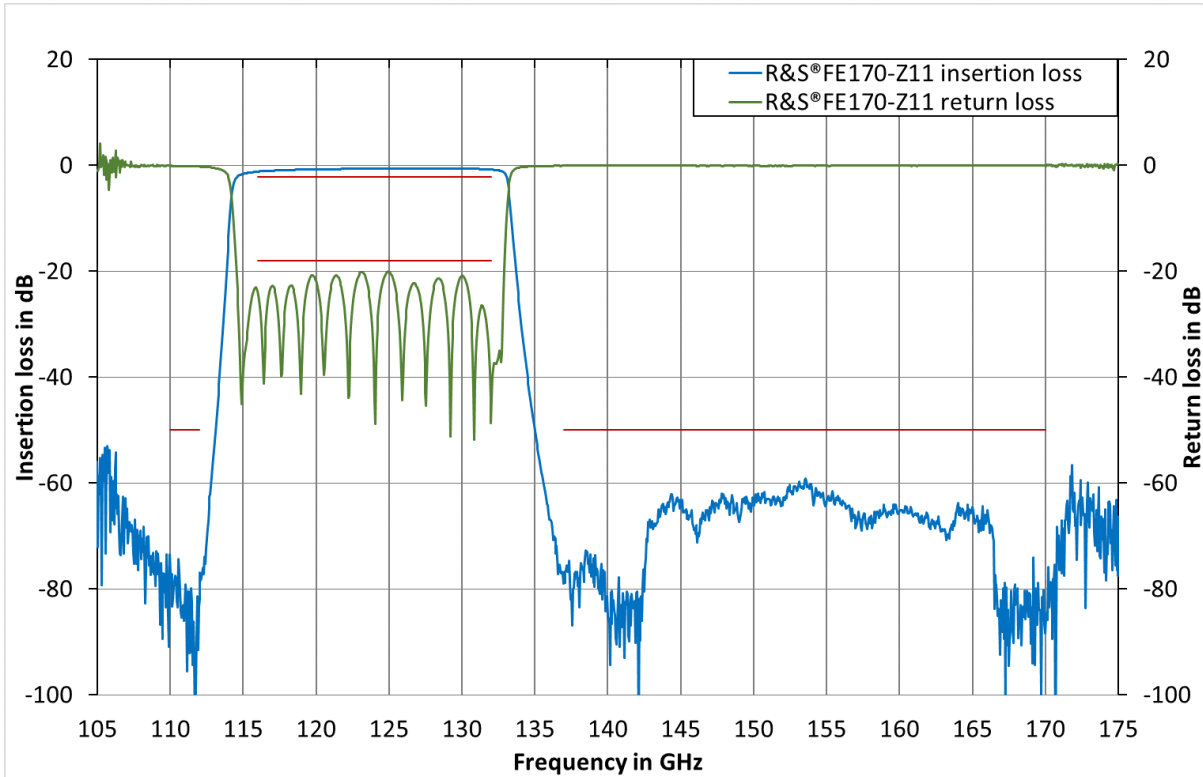

R&S®FE170-Z12

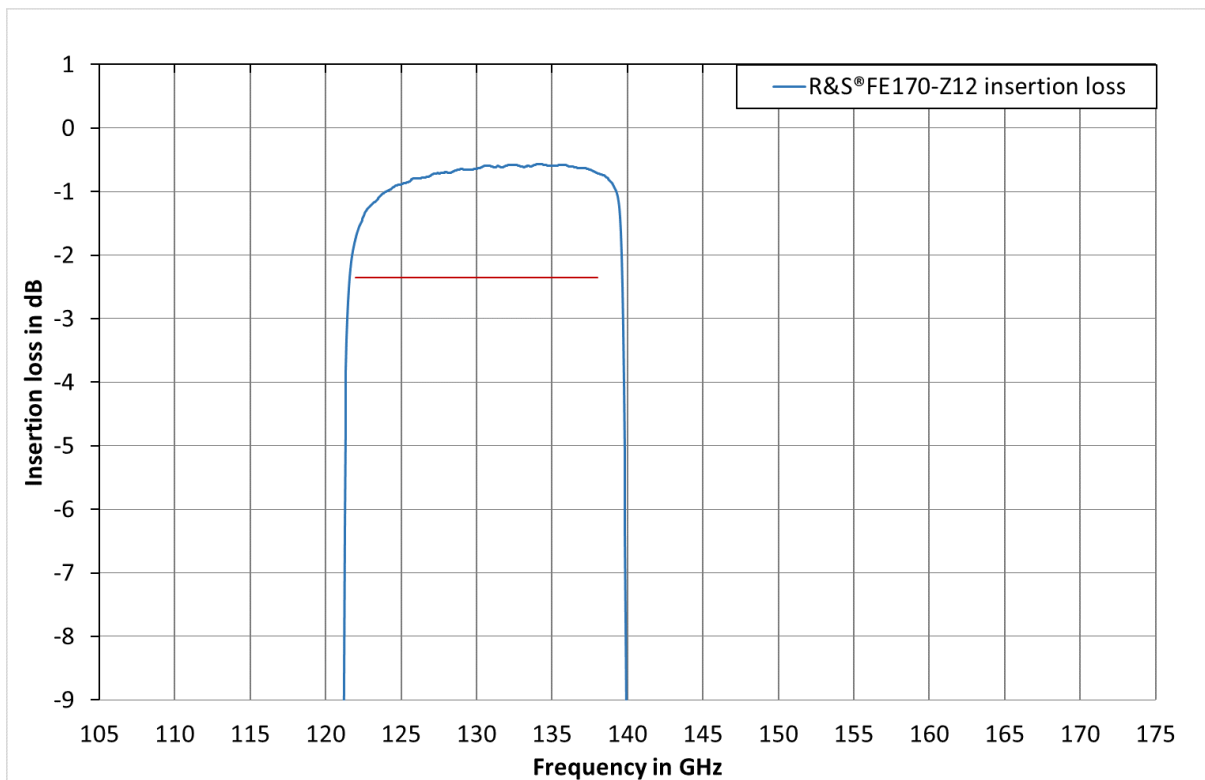
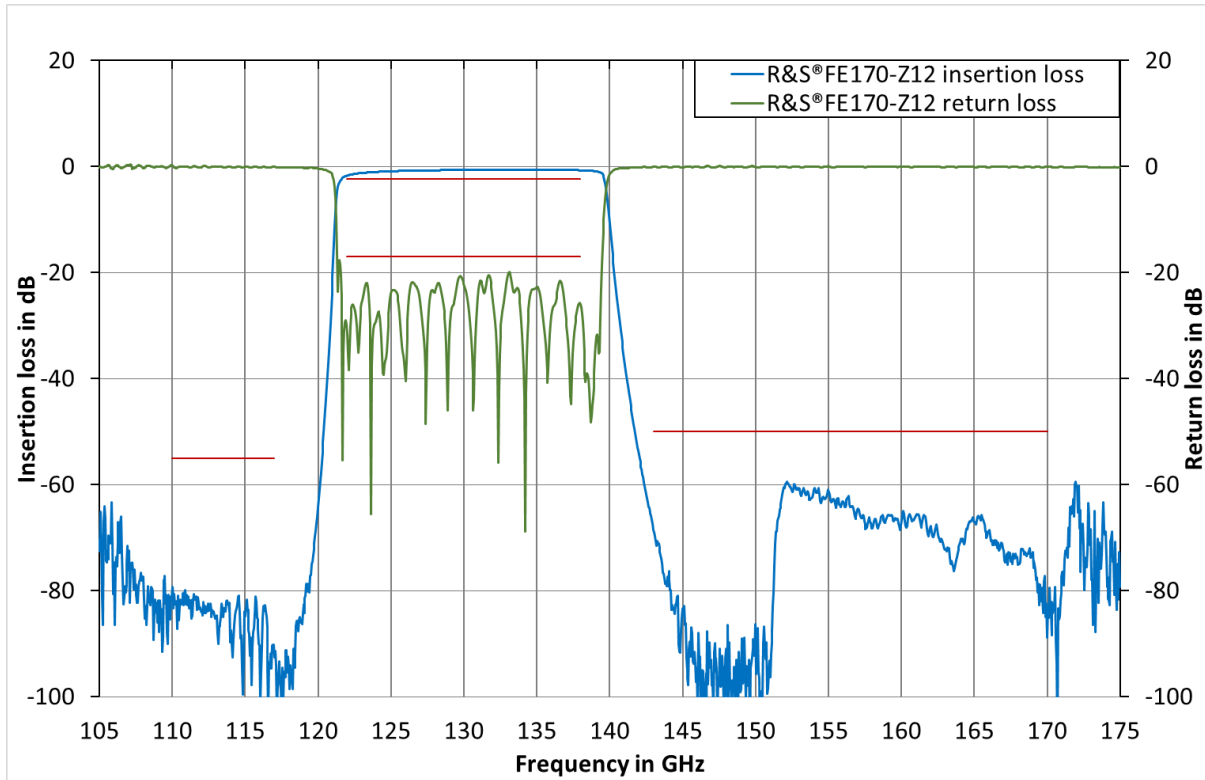

R&S®FE170-Z13

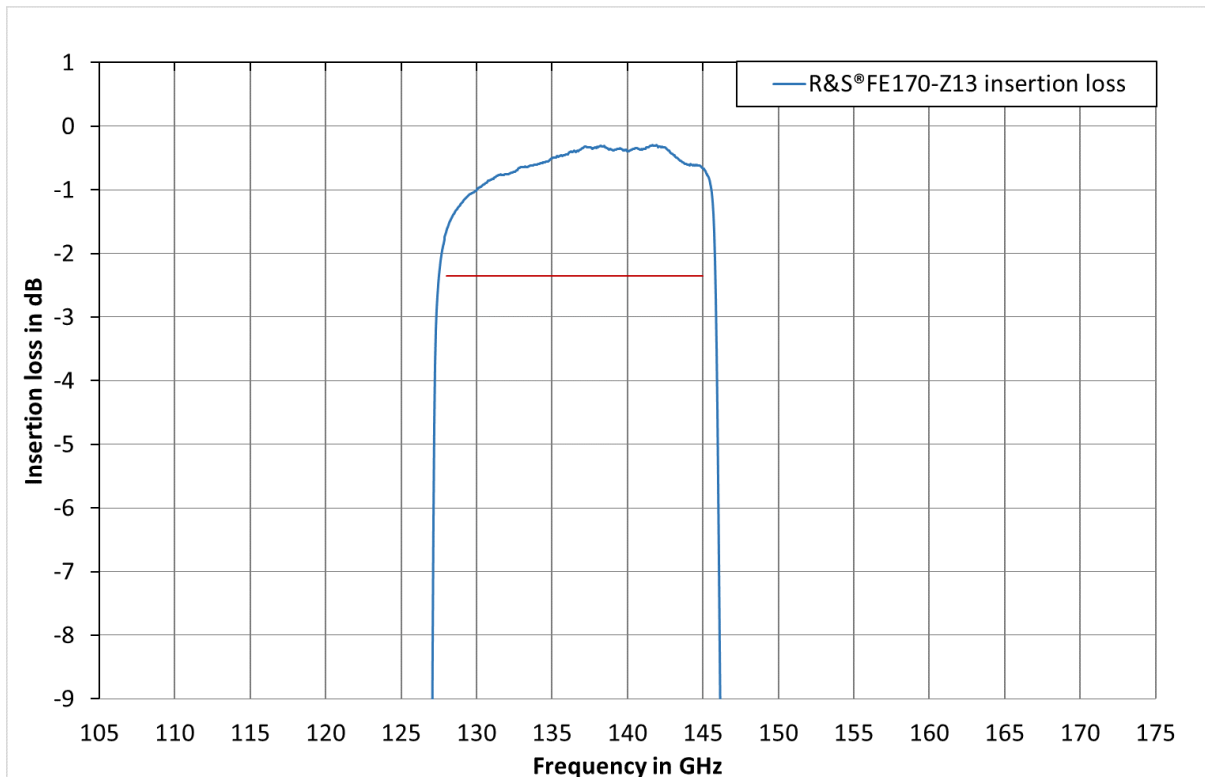
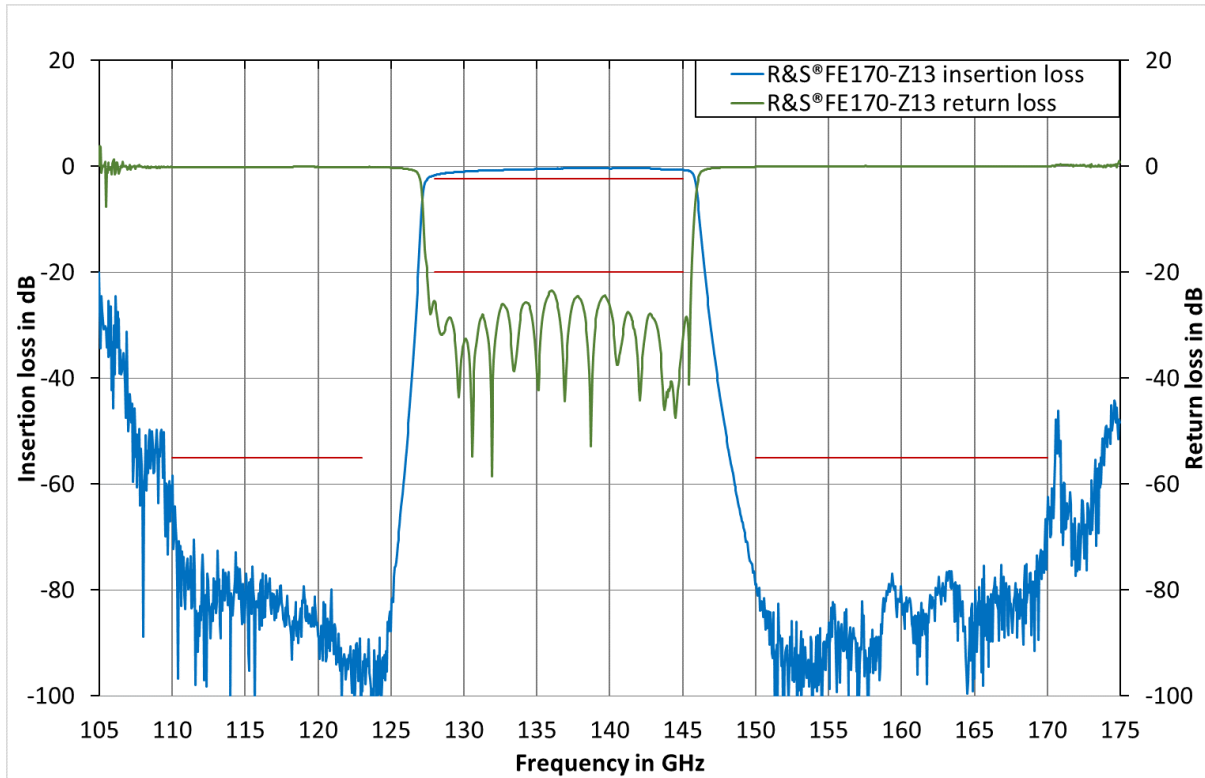

R&S®FE170-Z14

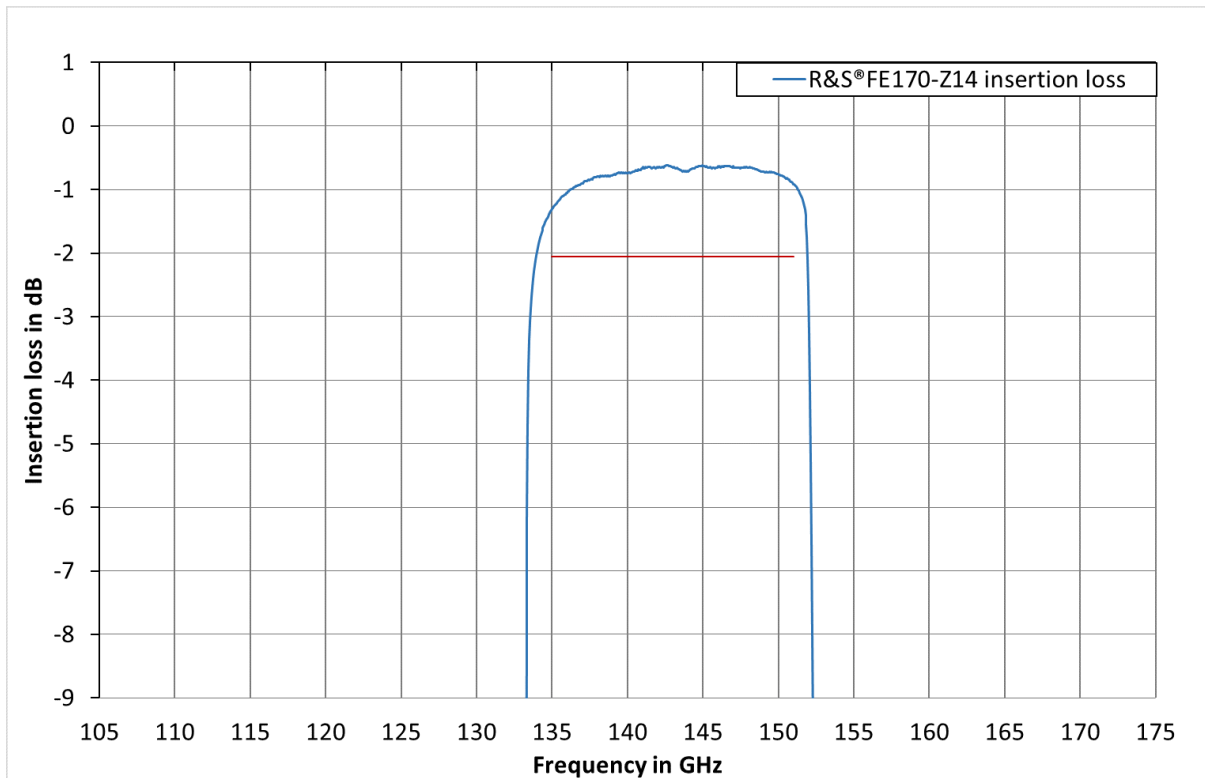
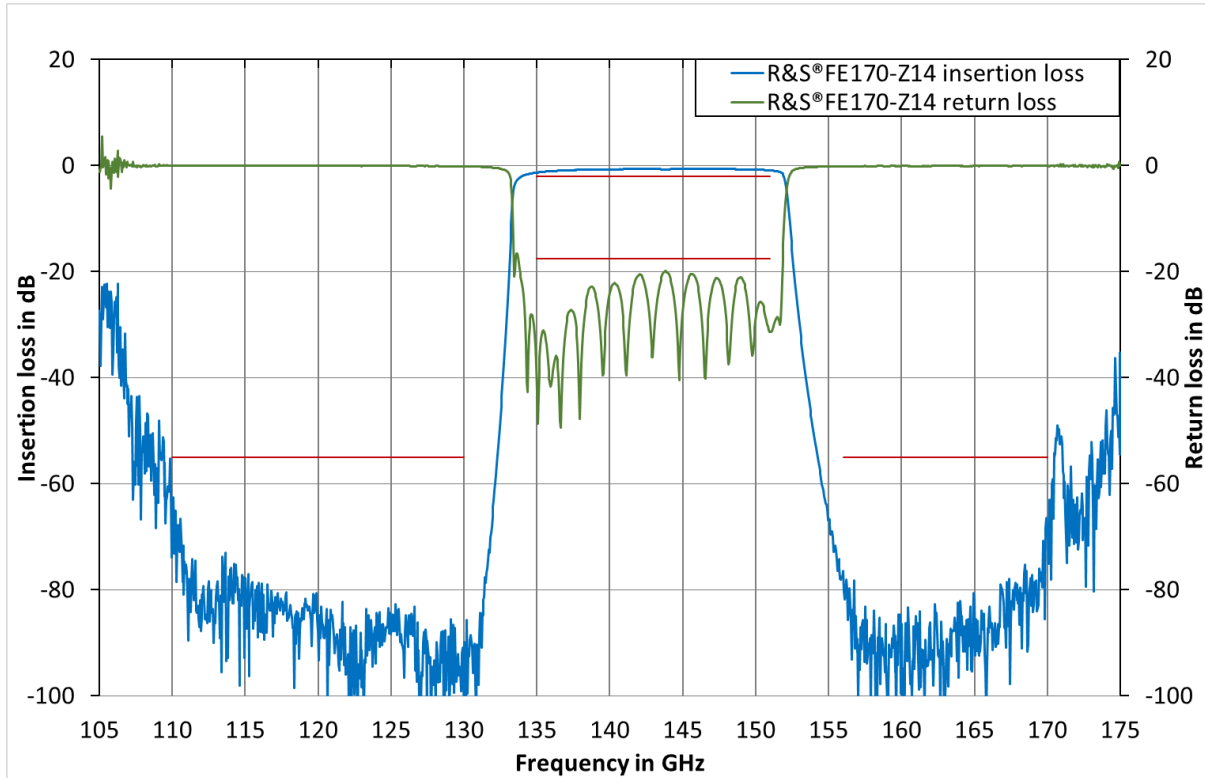

R&S®FE170-Z15

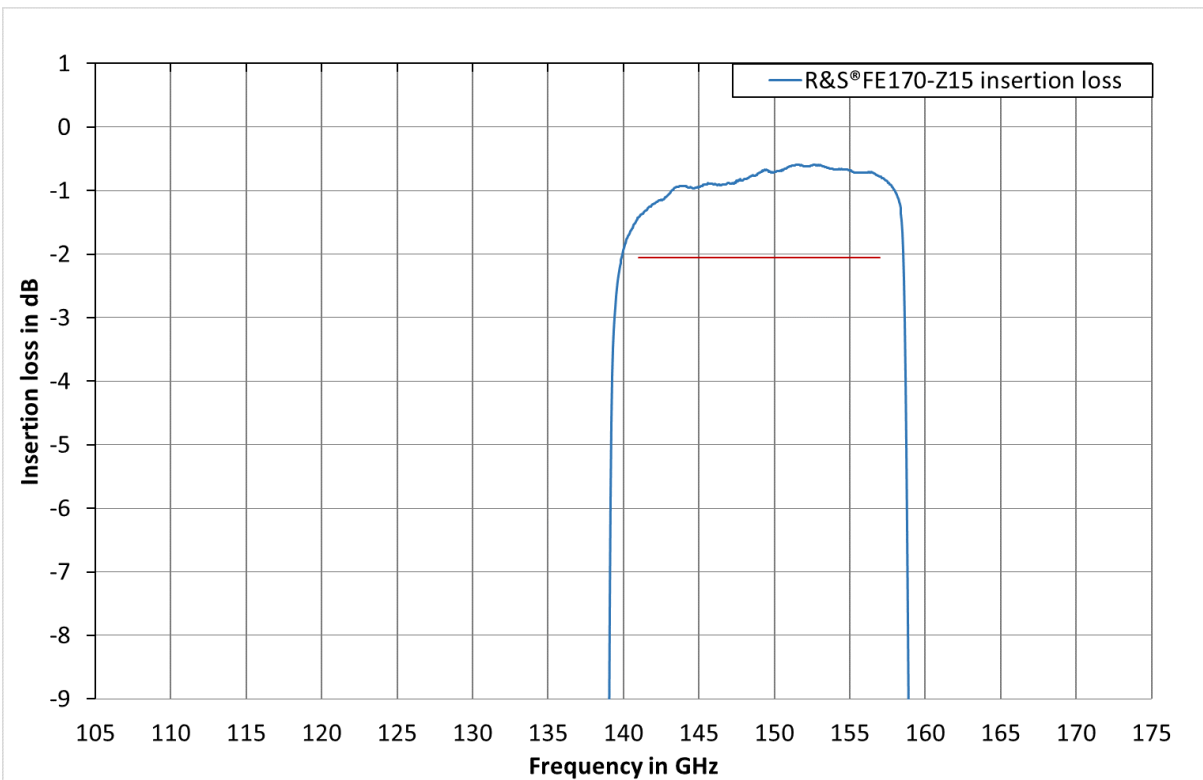
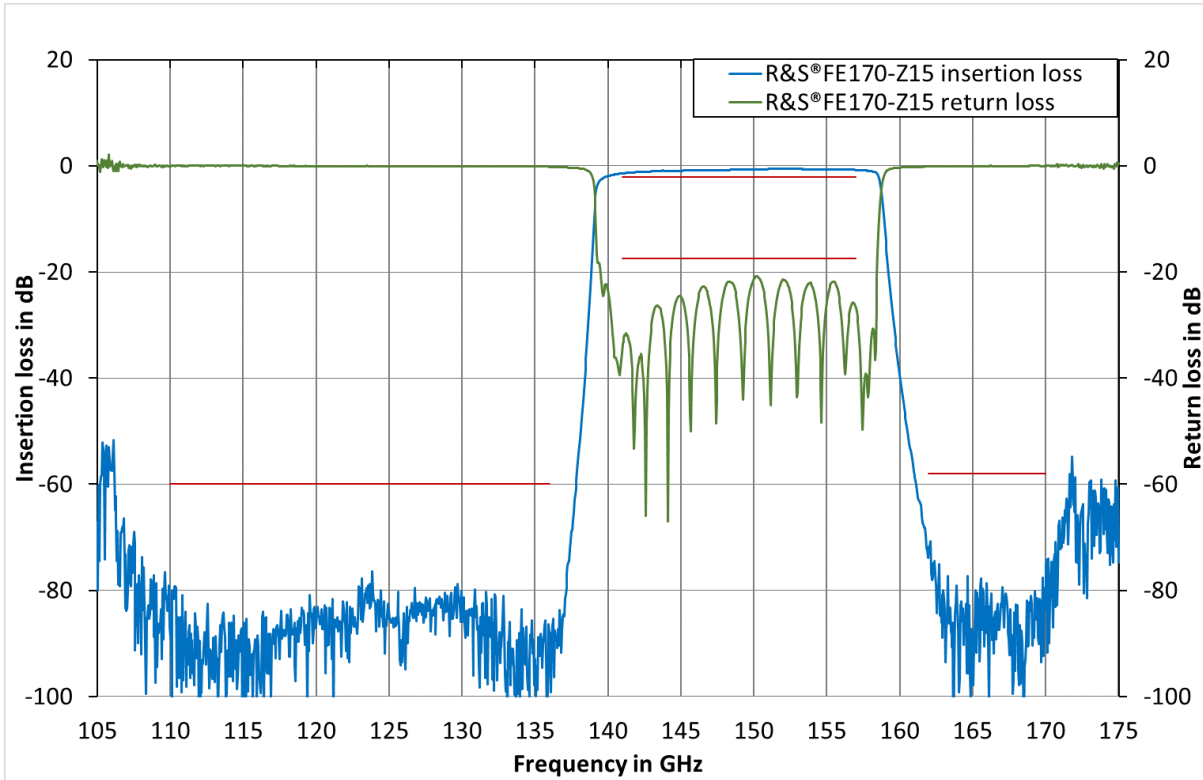

R&S®FE170-Z16

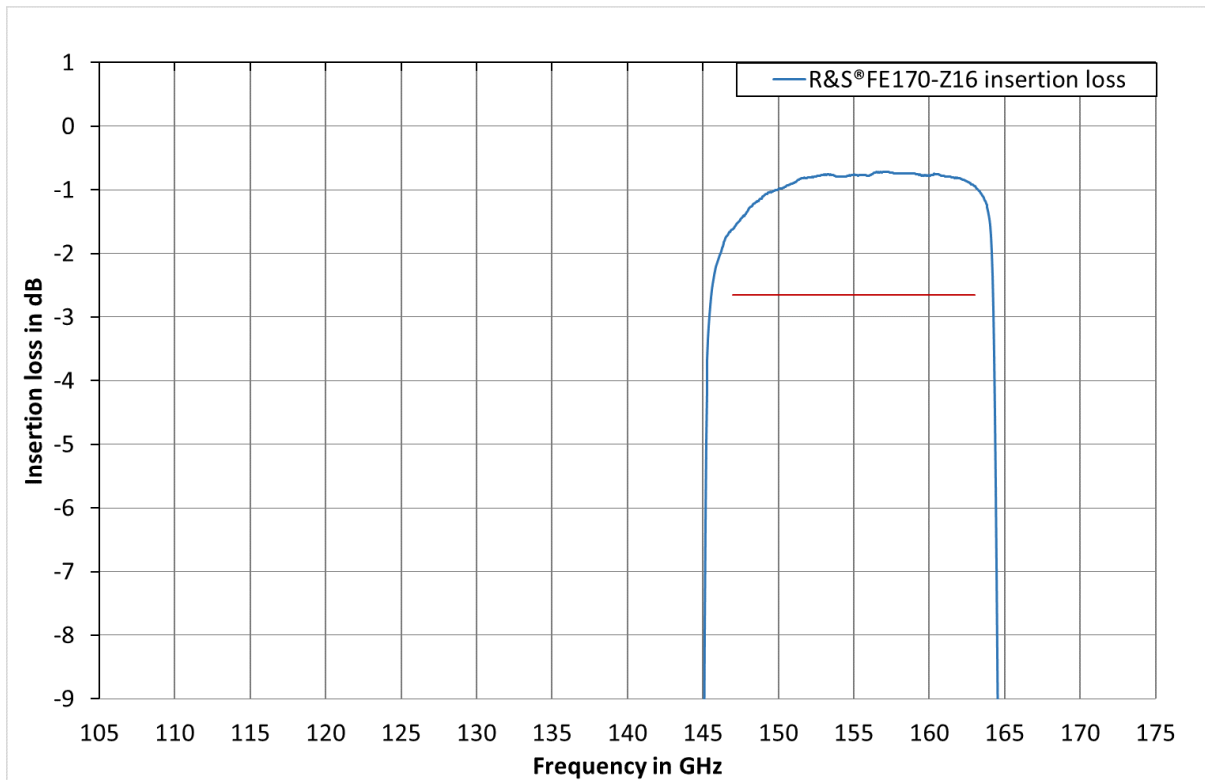
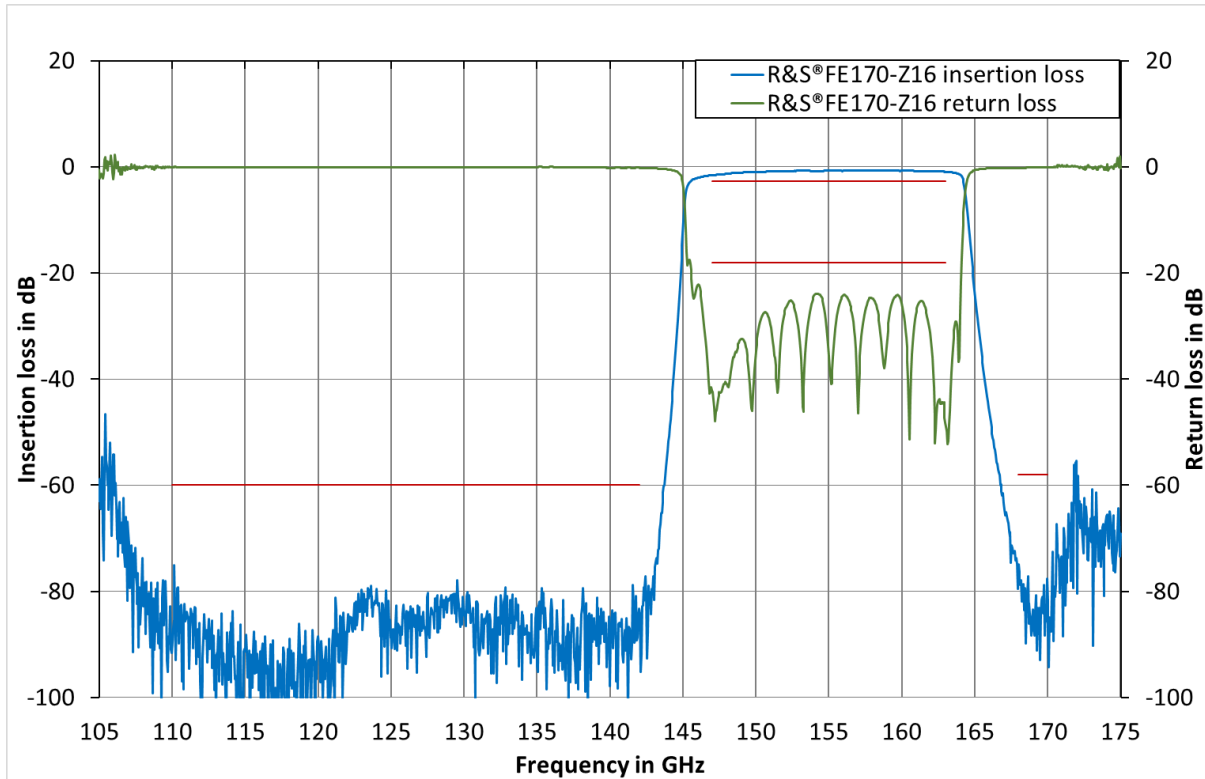

R&S®FE170-Z17

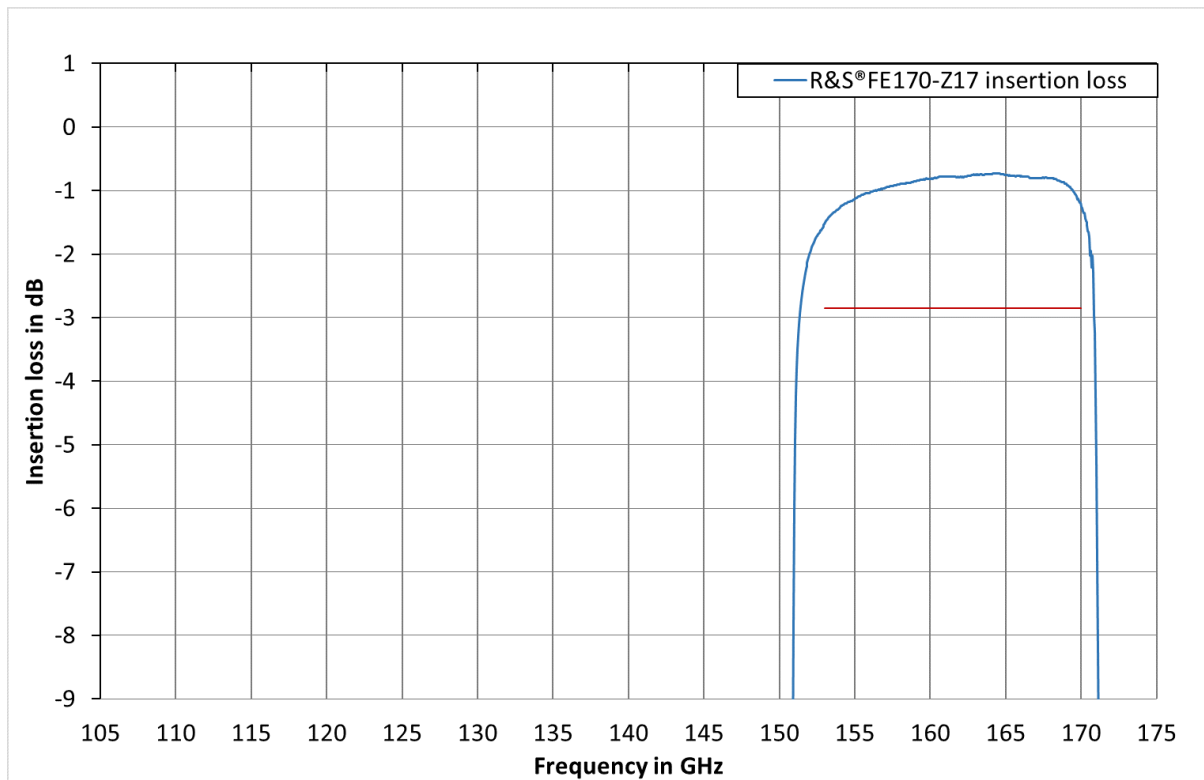
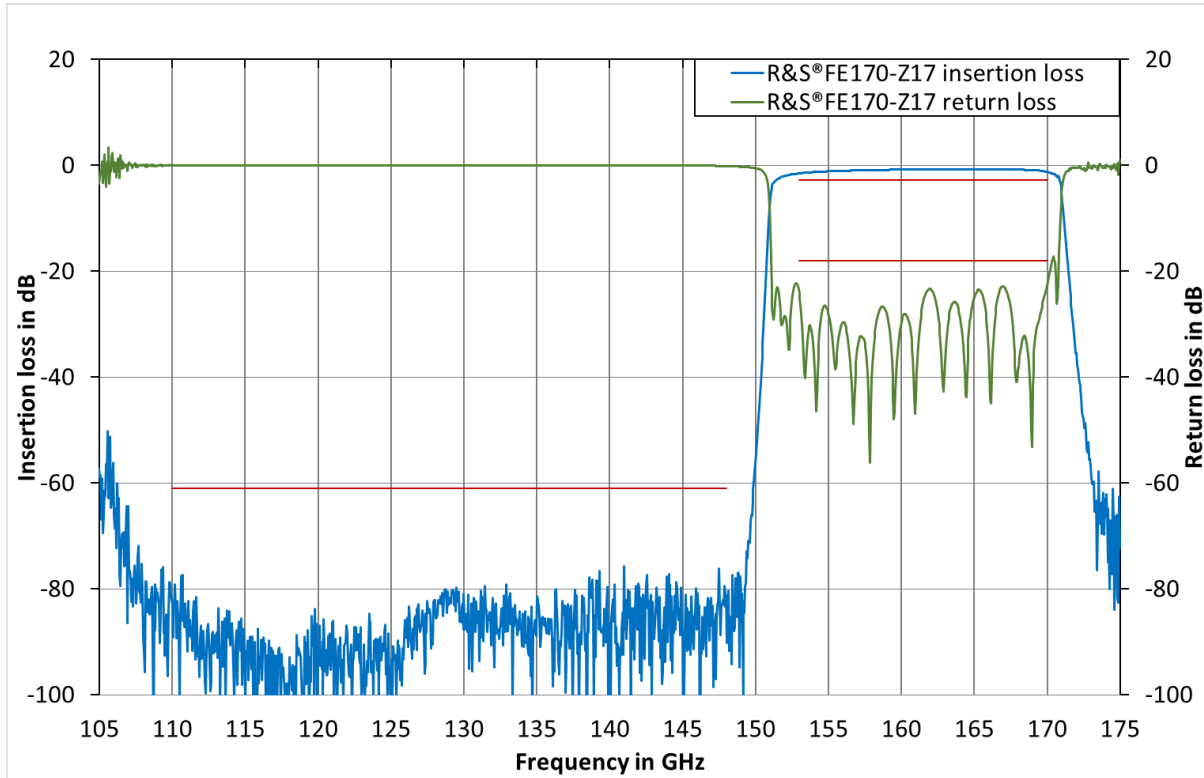

R&S®FE170-Z01/-Z02/-Z03/-Z04

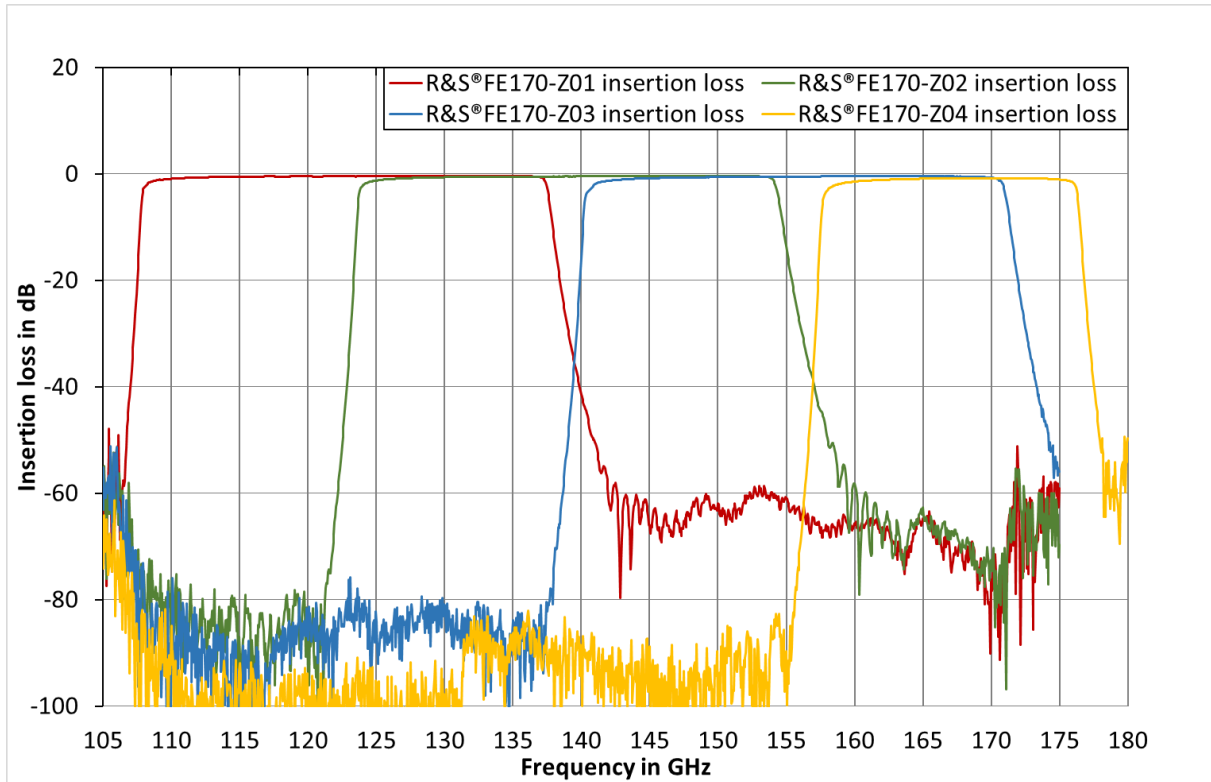

R&S®FE170-Z10/-Z11/-Z12/-Z13

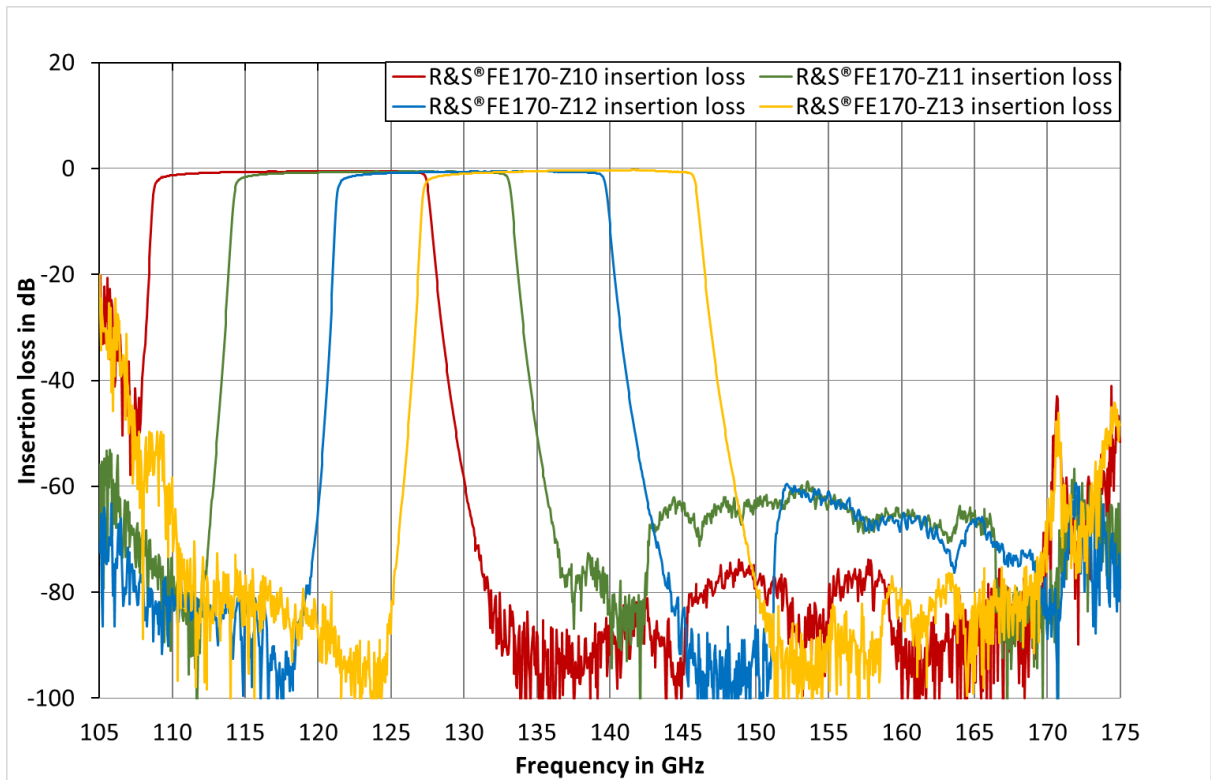

R&S®FE170-Z14/-Z15/-Z16/-Z17

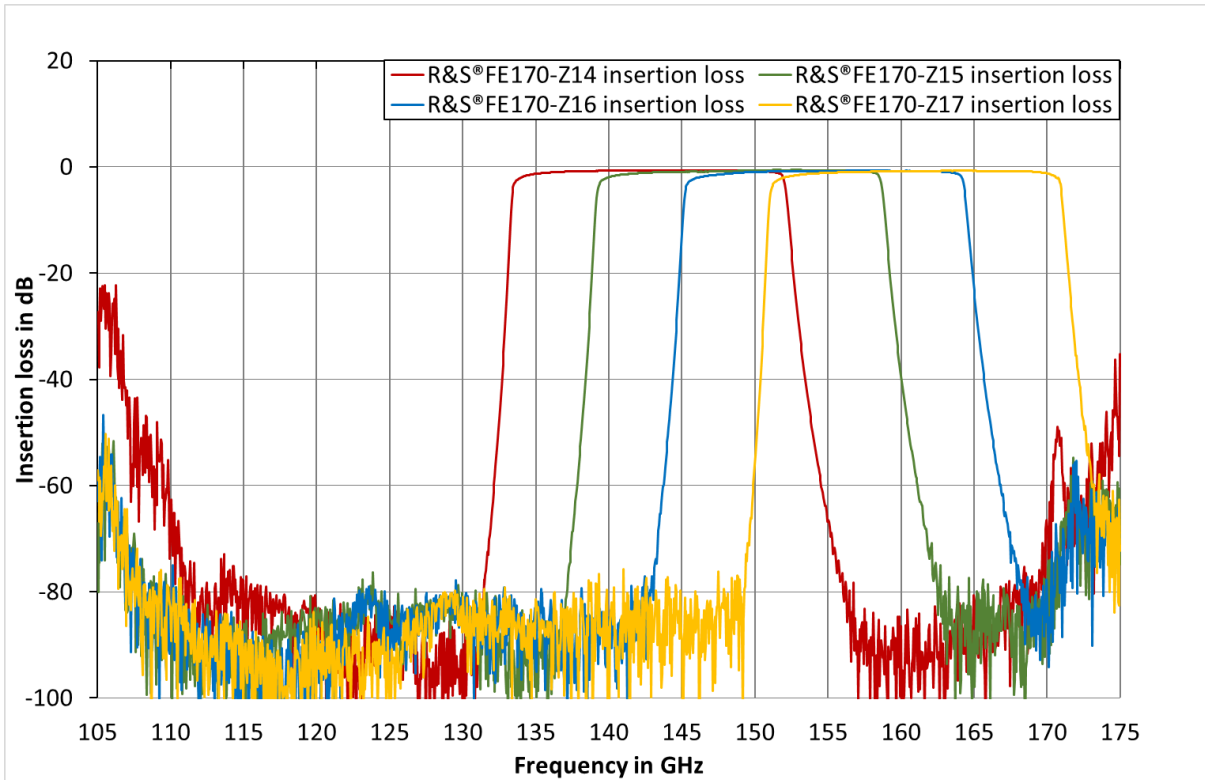

Outline drawing of R&S®FE170-Z01

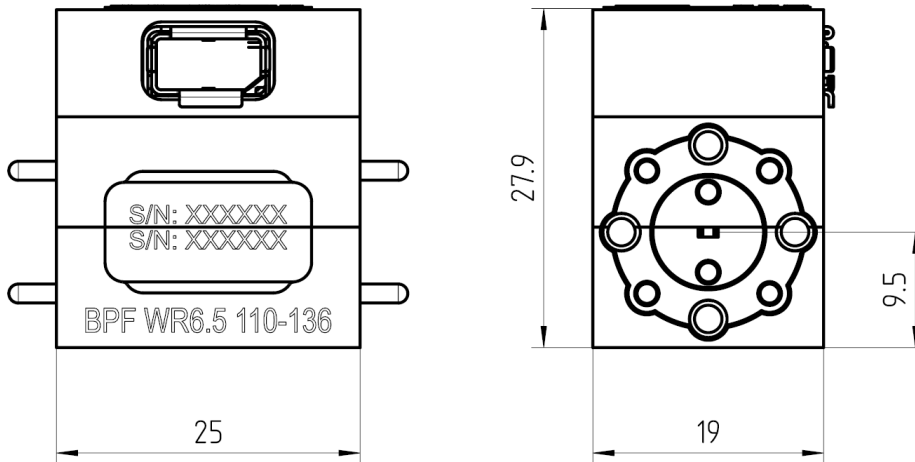

Inputs and outputs

RF input and output D band accessories		
Connector		WM1651/WR6.5
Flange		UG387/U-M

Digital interface accessories		
Connector		ix Industrial® type B

General data

Temperature		
Temperature range	operating	+5 °C to +40 °C
	storage	-40 °C to +70 °C
Climatic loading		+40 °C at 80 % relative humidity, in line with EN 60068-2-30, without condensation

Altitude		
Maximum operating altitude	above sea level	4600 m (approx. 15100 ft)

Mechanical resistance		
Vibration	sinusoidal	5 Hz to 55 Hz, displacement: 0.3 mm, constant amplitude (1.8 g at 55 Hz), in line with EN 60068-2-6
		55 Hz to 150 Hz, acceleration: 0.5 g constant, in line with EN 60068-2-6
	random	8 Hz to 500 Hz, acceleration 1.2 g (RMS), in line with EN 60068-2-64
Shock		40 g shock spectrum, in line with MIL-STD-810G, method 516.6, procedure I

EMC		
		<ul style="list-style-type: none"> • IEC/EN 61326-1 ^{1, 2} • IEC/EN 61326-2-1 • CISPR 11/EN 55011 ¹ • IEC/EN 61000-3-2 • IEC/EN 61000-3-3

Surface		
		plated gold

Dimensions and weight		
Dimensions (nom.)	W x H x D (overall)	19 mm x 28 mm x 25 mm (0.75 in x 1.10 in x 0.98 in)
Net weight (nom.)		53 g (0.12 lb)

¹ Emission limits for class A equipment applied.

² Immunity test requirement for industrial environment (EN 61326 table 2).

R&S®FE170-Z20 WR6.5 waveguide-to-waveguide adapter

The R&S®FE170-Z20 WR6.5 waveguide-to-waveguide adapter is available for the full frequency band from 110 GHz to 170 GHz with a mechanical length of 40 mm.

Electrical specifications

Frequency range	110 GHz to 170 GHz	110 GHz to 170 GHz
Insertion loss	$110 \text{ GHz} \leq f \leq 170 \text{ GHz}$	< 0.4 dB (meas.)
Return loss	$110 \text{ GHz} \leq f \leq 170 \text{ GHz}$	> 37 dB (meas.)

Measured insertion loss and return loss over frequency

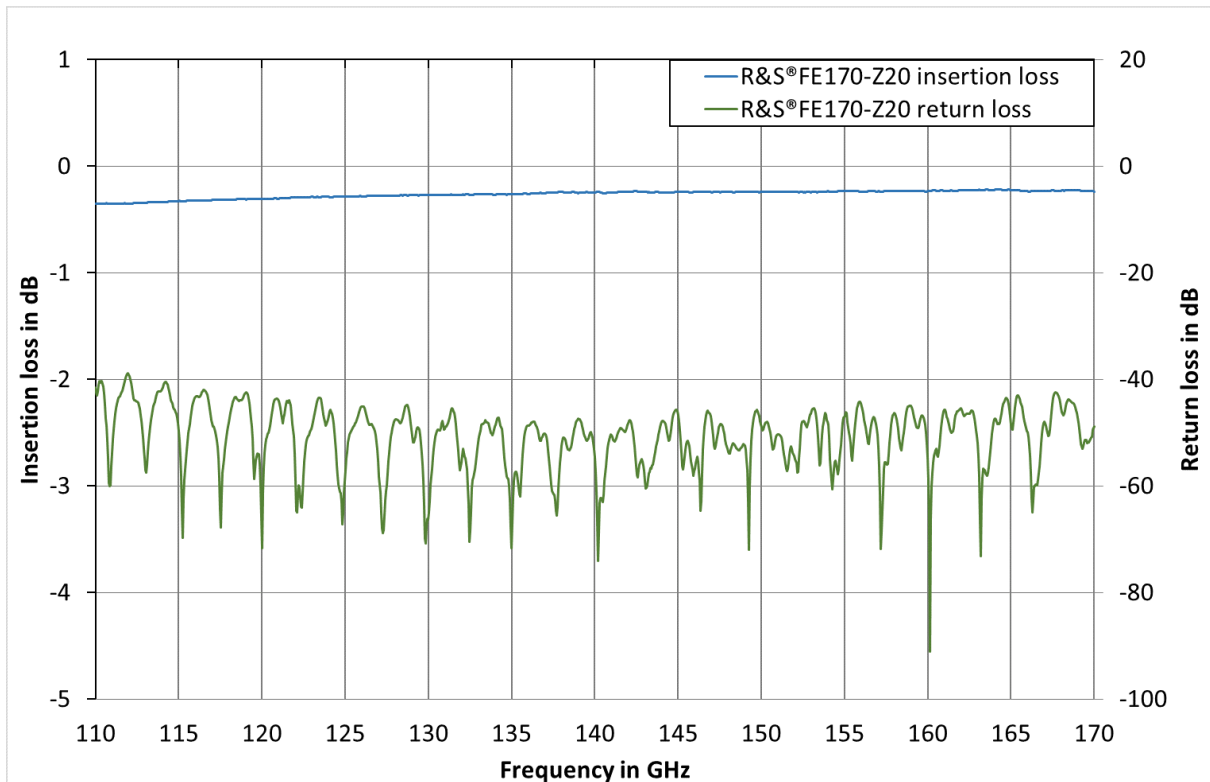

Outline drawing

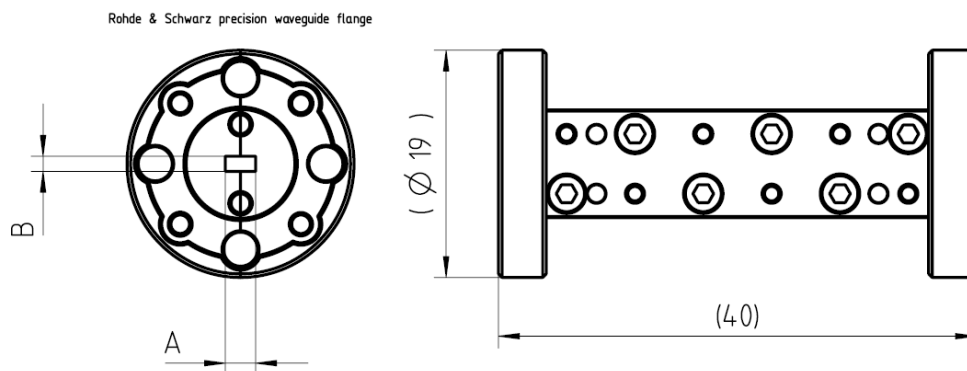

Inputs and outputs

RF input and output D band accessories		
Connector		WM1651/WR6.5
Flange		UG387/U-M

General data

Temperature		
Temperature range	operating	+5 °C to +40 °C
	storage	−40 °C to +70 °C
Climatic loading		+40 °C at 80 % relative humidity, in line with EN 60068-2-30, without condensation

Altitude		
Maximum operating altitude	above sea level	4600 m (approx. 15100 ft)

Mechanical resistance		
Vibration	sinusoidal	5 Hz to 55 Hz, displacement: 0.3 mm, constant amplitude (1.8 g at 55 Hz), in line with EN 60068-2-6
		55 Hz to 150 Hz, acceleration: 0.5 g constant, in line with EN 60068-2-6
	random	8 Hz to 500 Hz, acceleration 1.2 g (RMS), in line with EN 60068-2-64
Shock		40 g shock spectrum, in line with MIL-STD-810G, method 516.6, procedure I

Surface		plated gold
----------------	--	-------------

Dimensions and weight		
Dimensions (nom.)	W x H x D (overall)	19 mm x 19 mm x 40 mm (0.75 in x 0.75 in x 1.57 in)
Net weight (nom.)		40 g (0.09 lb)

R&S®FE170-Z50 full D band medium power amplifier

The R&S®FE170-Z50 medium power amplifier operates within the frequency range from 110 GHz to 170 GHz. The amplifier module includes an internal memory that contains identification information and calibration data. Rohde & Schwarz frontend units readout the stored data and will use them to correct for amplifier gain, thus the level at the user interface is calibrated. All testing was performed under +25 °C ambient temperature.

Electrical specifications

Frequency range		
R&S®FE170-Z50		110 GHz to 175 GHz
Gain		
R&S®FE170-Z50	110 GHz ≤ f ≤ 120 GHz	> 16 dB (meas.)
	120 GHz ≤ f ≤ 150 GHz	> 17 dB (meas.)
	150 GHz ≤ f ≤ 170 GHz	> 18 dB (meas.)
	170 GHz ≤ f ≤ 175 GHz	> 16 dB (meas.)
Input return loss		
R&S®FE170-Z50	110 GHz ≤ f ≤ 120 GHz	> 16 dB (meas.)
	120 GHz ≤ f ≤ 155 GHz	> 17 dB (meas.)
	155 GHz ≤ f ≤ 170 GHz	> 14 dB (meas.)
	170 GHz ≤ f ≤ 175 GHz	> 12 dB (meas.)
Output return loss		
R&S®FE170-Z50	110 GHz ≤ f ≤ 140 GHz	> 14 dB (meas.)
	140 GHz ≤ f ≤ 150 GHz	> 11 dB (meas.)
	150 GHz ≤ f ≤ 175 GHz	> 13 dB (meas.)
Reverse isolation		
R&S®FE170-Z50	110 GHz ≤ f ≤ 170 GHz	> 45 dB (meas.)
	170 GHz ≤ f ≤ 175 GHz	> 40 dB (meas.)
Saturation power		
R&S®FE170-Z50	110 GHz ≤ f ≤ 160 GHz	> 15 dBm (meas.)
	160 GHz ≤ f ≤ 165 GHz	> 15 dBm (meas.)
	165 GHz ≤ f ≤ 170 GHz	> 14 dBm (meas.)
	170 GHz ≤ f ≤ 175 GHz	> 13 dBm (meas.)
P1dB compression point		
R&S®FE170-Z50	110 GHz ≤ f ≤ 150 GHz	> 10 dBm (meas.)
Maximum input power		
R&S®FE170-Z50	110 GHz ≤ f ≤ 170 GHz	< 5 dBm

Measured gain and return loss over frequency

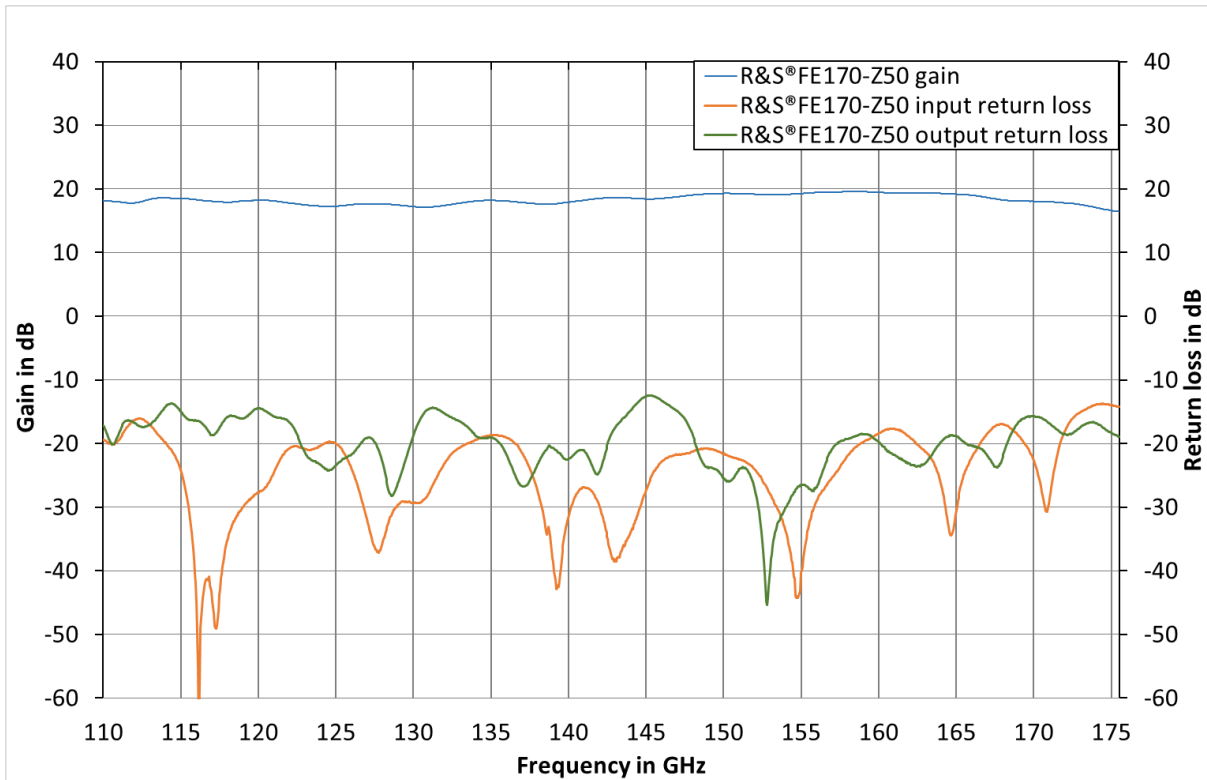

Measured saturation power over frequency

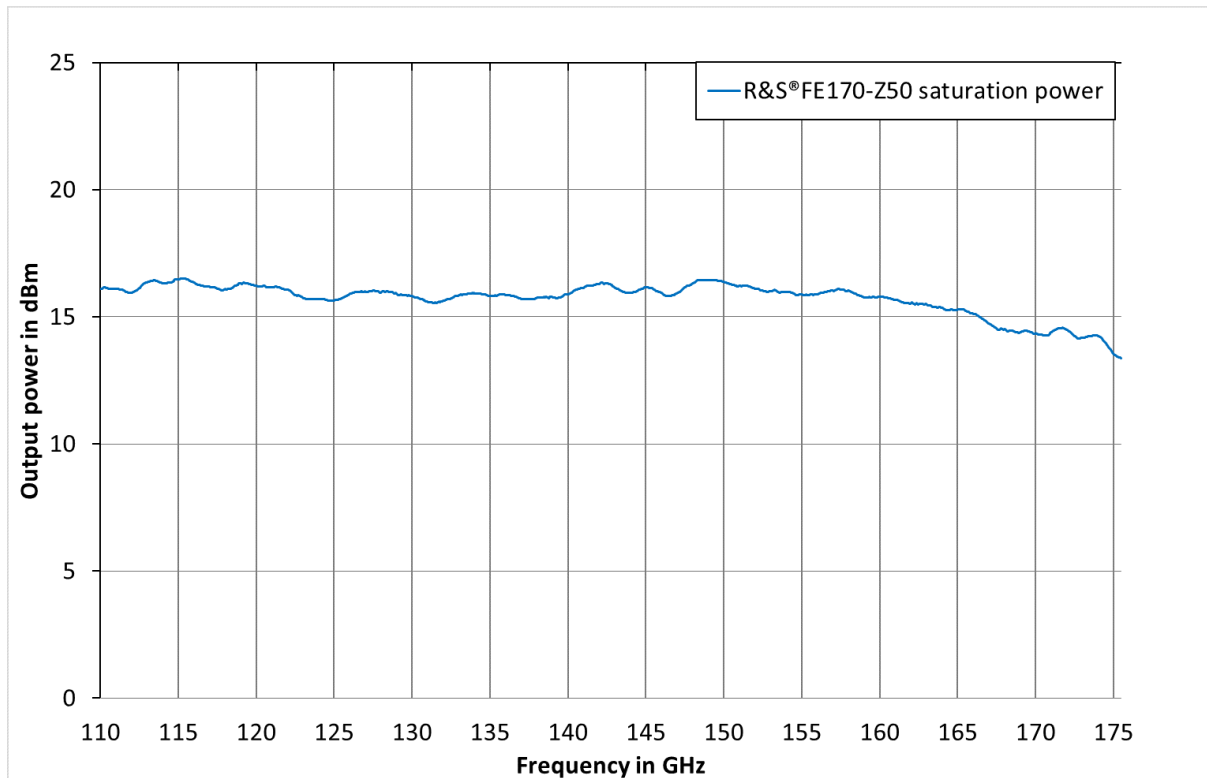

Outline drawing

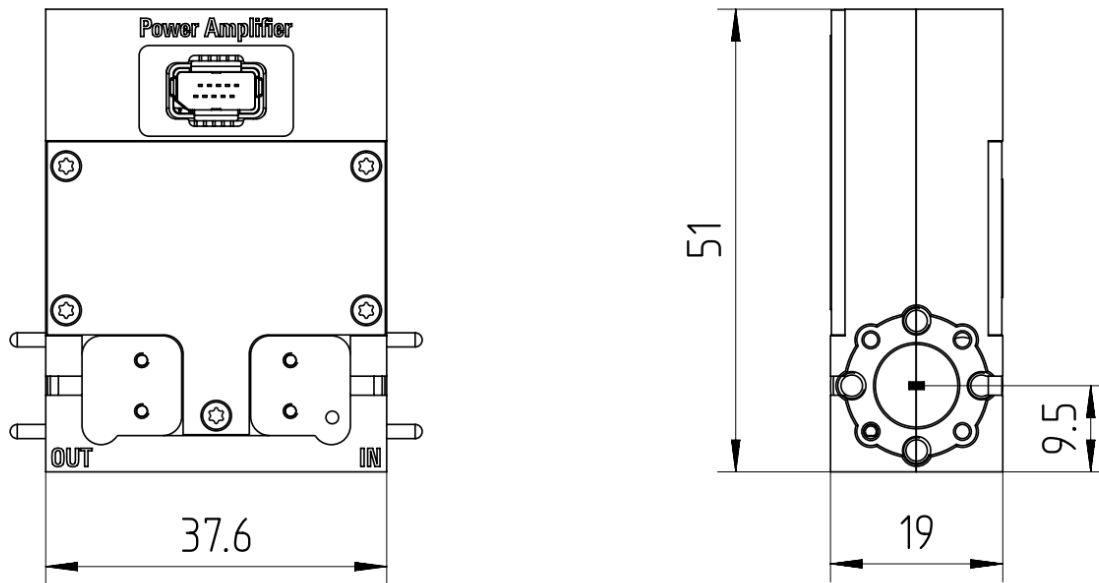

Inputs and outputs

Input and output D band accessories		
Connector		WM1651/WR6.5
Flange		UG387/U-M
Bias		ix type B connector

General data

Temperature		
Temperature range	operating	+5 °C to +40 °C
	maximum case temperature	+50 °C

Mechanical resistance		
Vibration	sinusoidal	5 Hz to 55 Hz, displacement: 0.3 mm, constant amplitude (1.8 g at 55 Hz), in line with EN 60068-2-6
		55 Hz to 150 Hz, acceleration: 0.5 g constant, in line with EN 60068-2-6
	random	8 Hz to 500 Hz, acceleration 1.2 g (RMS), in line with EN 60068-2-64
Shock		40 g shock spectrum, in line with MIL-STD-810G, method 516.6, procedure I

Surface		
		plated gold

Dimensions and weight		
Dimensions (nom.)	W x H x D (overall)	51 mm x 37.6 mm x 19 mm (2 in x 1.48 in x 0.75 in)
Net weight (nom.)		200 g (0.44 lb)

Ordering information

Designation	Type	Order No.
Waveguide filter, 110 GHz to 136 GHz	R&S®FE170-Z01	1347.9532.02
Waveguide filter, 126 GHz to 153 GHz	R&S®FE170-Z02	1347.9549.02
Waveguide filter, 143 GHz to 170 GHz	R&S®FE170-Z03	1347.9555.02
Waveguide filter, 160 GHz to 175 GHz	R&S®FE170-Z04	1348.7656.02
Waveguide filter, 110 GHz to 126 GHz	R&S®FE170-Z10	1347.9661.02
Waveguide filter, 116 GHz to 132 GHz	R&S®FE170-Z11	1347.9678.02
Waveguide filter, 122 GHz to 138 GHz	R&S®FE170-Z12	1347.9684.02
Waveguide filter, 128 GHz to 145 GHz	R&S®FE170-Z13	1347.9690.02
Waveguide filter, 135 GHz to 151 GHz	R&S®FE170-Z14	1348.7610.02
Waveguide filter, 141 GHz to 157 GHz	R&S®FE170-Z15	1348.7627.02
Waveguide filter, 147 GHz to 163 GHz	R&S®FE170-Z16	1348.7633.02
Waveguide filter, 153 GHz to 170 GHz	R&S®FE170-Z17	1348.7640.02
WR6.5 waveguide-to-waveguide adapter	R&S®FE170-Z20	1347.9655.02
Full D band power amplifier	R&S®FE170-Z50	1347.9584.02

Recommended extras

Designation	Type	Order No.
Torque wrench, for waveguide flanges, 0.58 Nm	R&S®ZN-ZCTW	1175.2014.02
Angled wrench, 3/32"	R&S®ZCAW	1175.1960.00

Service options

Warranty		1 year
Service options		
Extended warranty, one year	R&S®WE1	Contact your local Rohde & Schwarz sales office.
Extended warranty, two years	R&S®WE2	
Extended warranty, three years	R&S®WE3	
Extended warranty, four years	R&S®WE4	
Extended warranty with calibration coverage, one year	R&S®CW1	
Extended warranty with calibration coverage, two years	R&S®CW2	
Extended warranty with calibration coverage, three years	R&S®CW3	
Extended warranty with calibration coverage, four years	R&S®CW4	

Extended warranty with a term of one and two years (WE1 to WE4)

Repairs carried out during the contract term are free of charge ³. Necessary calibration and adjustments carried out during repairs are also covered.

Extended warranty with calibration coverage (CW1 to CW4)

Enhance your extended warranty by adding calibration coverage at a package price. This package ensures that your Rohde & Schwarz product is regularly calibrated, inspected and maintained during the term of the contract. It includes all repairs ³ and calibration at the recommended intervals as well as any calibration carried out during repairs or option upgrades.

³ Excluding defects caused by incorrect operation or handling and force majeure. Wear-and-tear parts are not included.

Service at Rohde & Schwarz You're in great hands

- ▶ Worldwide
- ▶ Local and personalized
- ▶ Customized and flexible
- ▶ Uncompromising quality
- ▶ Long-term dependability

Rohde & Schwarz

The Rohde&Schwarz technology group is among the trailblazers when it comes to paving the way for a safer and connected world with its leading solutions in test & measurement, technology systems and networks&cybersecurity. Founded 90 years ago, the group is a reliable partner for industry and government customers around the globe. The independent company is headquartered in Munich, Germany and has an extensive sales and service network with locations in more than 70 countries.

www.rohde-schwarz.com

Sustainable product design

- ▶ Environmental compatibility and eco-footprint
- ▶ Energy efficiency and low emissions
- ▶ Longevity and optimized total cost of ownership

Certified Quality Management

ISO 9001

Certified Environmental Management

ISO 14001

Rohde & Schwarz training

www.training.rohde-schwarz.com

Rohde & Schwarz customer support

www.rohde-schwarz.com/support

