

ROHDE & SCHWARZ

Make ideas real



R&S®ATS1800C COMPACT 3GPP COMPLIANT OTA CHAMBER FOR 5G NR mmWAVE SIGNALS

Specifications | Version 04.00

Specifications



CONTENTS

Definitions	4
Specifications.....	5
R&S®ATS1800C K03 system performance	5
R&S®CATR-REFL1 CATR reflector, regular size	6
R&S®CATR-REFL6 CATR reflector, large size	7
R&S®CATR-FE4 OOB feed horn antenna, for CATR system	7
R&S®CATR-FE30 feed horn antenna, for CATR system	7
R&S®CATR-FE40 feed antenna with OMT, for CATR system	7
R&S®CATR-FE60 feed antenna with OMT, for CATR system	7
R&S®CATR-FE90 feed antenna with OMT, for CATR system	7
R&S®CATR-TEMP2 extreme temperature condition	7
R&S®CATR-CAM1 camera option, visual and thermal combined	8
R&S®CATR-MIMOA 4x4 MIMO anker.....	8
R&S®CATR-RFRJ2 dual RF rotary joint extension on azimuth.....	8
R&S®TC-TA50CPR link antenna, ruggedized Vivaldi	8
R&S®CATR-MNT2 mounting kit, for rear side mounting of RRH and RF42	8
R&S®CATR- HFIX1 phantom fixture or heavy DUT mounting	8
R&S®CATR-FX4 fixed feed holder, for R&S®CATR-FE4	8
R&S®CATR-FX30 fixed feed holder, for R&S®CATR-FE30	8
R&S®CATR-FX40 fixed feed holder, for R&S®CATR-FE40	9
R&S®CATR-FX60 fixed feed holder, for R&S®CATR-FE60	9
CATR-FX90 fixed feed holder, for R&S®CATR-FE90.....	9
R&S®CATR-FESWA automatic feed switcher	9
R&S®CATR-FL4 feed holder, for R&S®CATR-FE4 on automatic feed switcher	9
R&S®CATR-FL30 feed holder, for R&S®CATR-FE30 on automatic feed switcher	9
R&S®CATR-FL40 feed holder, for R&S®CATR-FE40 on automatic feed switcher	9
R&S®CATR-FL60 feed holder, for R&S®CATR-FE60 on automatic feed switcher	10
R&S®CATR-FL90 feed holder, for R&S®CATR-FE90 on automatic feed switcher	10
R&S®TS-QOQZIB in-band quality of quiet zone assessment fixture kit	10
R&S®CATR-SCML1 left side chamber option, for multiple angle of arrival	10
R&S®CATR-SCMR2 right side chamber option, for multiple angle of arrival.....	11
R&S®CATR-FM4 feed holder, for R&S®CATR-FE4 in side-chamber	11
R&S®CATR-FM30 feed holder, for R&S®CATR-FE30 in side-chamber	11
R&S®CATR-FM40 feed holder, for R&S®CATR-FE40 in side-chamber	11
R&S®CATR-FM60 feed holder, for R&S®CATR-FE60 in side-chamber	11
R&S®CATR-FM90 feed holder, for R&S®CATR-FE90 in side-chamber	11

Ordering information	12
Basic configuration	12
Additional options	12
Accessories for calibration	12
Other accessories.....	12
Drawings.....	13

Definitions

General

Product data applies under the following conditions:

- Three hours of storage at ambient temperature followed by 30 minutes of warm-up operation
- Specified environmental conditions met
- Recommended calibration interval adhered to
- All internal automatic adjustments performed, if applicable

Specifications with limits

Represent warranted product performance by means of a range of values for the specified parameter. These specifications are marked with limiting symbols such as $<$, \leq , $>$, \geq , \pm or descriptions such as maximum, limit of, minimum. Compliance is ensured by testing or is derived from the design. Test limits are narrowed by guard bands to take into account measurement uncertainties, drift and aging, if applicable.

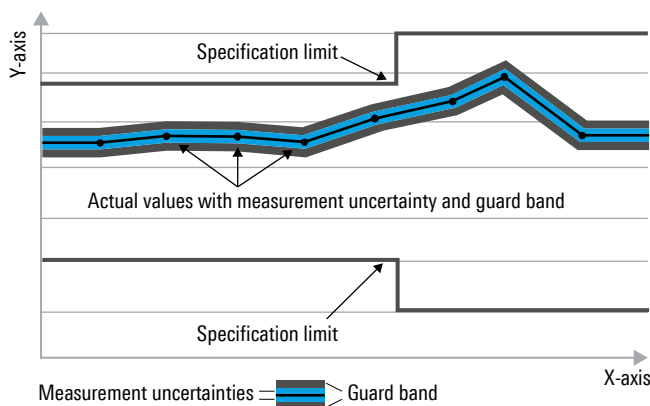

Non-traceable specifications with limits (n. trc.)

Represent product performance that is specified and tested as described under “Specifications with limits” above. However, product performance in this case cannot be warranted due to the lack of measuring equipment traceable to national metrology standards. In this case, measurements are referenced to standards used in the Rohde & Schwarz laboratories.

Specifications without limits

Represent warranted product performance for the specified parameter. These specifications are not specially marked and represent values with no or negligible deviations from the given value, e.g. dimensions or resolution of a setting parameter. Compliance is ensured by design.

Typical data (typ.)

Characterizes product performance by means of representative information for the given parameter. When marked with $<$, $>$ or as a range, it represents the performance met by approximately 80 % of the instruments at production time. Otherwise, it represents the mean value.

Nominal values (nom.)

Characterize product performance by means of a representative value for the given parameter, e.g. nominal impedance. In contrast to typical data, a statistical evaluation does not take place and the parameter is not tested during production.

Measured values (meas.)

Characterize expected product performance by means of measurement results gained from individual samples.

Uncertainties

Represent limits of measurement uncertainty for a given measurand. Uncertainty is defined with a coverage factor of 2 and has been calculated in line with the rules of the Guide to the Expression of Uncertainty in Measurement (GUM), taking into account environmental conditions, aging, wear and tear.

Device settings and GUI parameters are designated with the format “parameter: value”.

Non-traceable specifications with limits, typical data as well as nominal and measured values are not warranted by Rohde & Schwarz.

In line with the 3GPP standard, chip rates are specified in million chips per second (Mcps), whereas bit rates and symbol rates are specified in billion bit per second (Gbps), million bit per second (Mbps), thousand bit per second (kbps), million symbols per second (Msps) or thousand symbols per second (ksps), and sample rates are specified in million samples per second (Msample/s). Gbps, Mcps, Mbps, Msps, kbps, ksps and Msample/s are not SI units.

Specifications

The R&S®ATS1800C is a CATR based compact and accurate test chamber for RF testing of antennas, modules or devices in the 5G NR FR2 frequency bands. Values specified are based on system performance level, some individual items might perform better isolated.

R&S®ATS1800C K03 system performance

General RF parameters		
Frequency range	in-band	23.5 GHz to 44.3 GHz (meas.)
	out-of-band	6 GHz to 92 GHz
Shielding effectiveness ¹	chamber	> 90 dB (meas.)
Feed antenna polarization		dual polarized
RF connectors	feed antenna H/V feedthrough	2 x PC 1.85 mm (f)
	link/DUT feedthrough	1 x PC 1.85 mm (f)

Quality of quiet zone (QZ) ²		
Quiet zone size	with installed R&S®CATR-REFL1 option	Ø 30 cm
	with installed R&S®CATR-REFL6 option	Ø 40 cm
Amplitude performance ³	average amplitude taper	< 1.5 dB (meas.)
	average amplitude ripple	< 0.5 dB (meas.)
Total phase variation ⁴	at 28 GHz	±7.5° (meas.)
	at 39 GHz	±10° (meas.)
Range path loss ⁴	at 28 GHz	< 51 dB
	at 39 GHz	< 53 dB

Chamber specifications		
Power consumption		100 V to 120 V/200 V to 240 V (AC), 50 Hz to 60 Hz/max. 5 A
Power plug		C20
Internal power socket outlet	DUT power supply	100 V to 230 V (AC), max. 2 A
Weight		approx. 500 kg (1102.31 lb)
Dimensions	W x H x D	0.90 m x 1.99 m x 1.53 m (35.43 in x 78.35 in x 60.24 in)
Wheels	lockable	4
Door operation		manually operated, electrical closing mechanism
Ventilation rate		140 m ³ /h (nom.)
Noise level		38 dB(A) (nom.)

¹ From 650 MHz to 60 GHz.

² From 23.5 GHz to 44.3 GHz with R&S®CATR-FE40.

³ Measured from 23.5 GHz to 92 GHz.

⁴ Measured with R&S®CATR-REFL1 and R&S®CATR-FE40 for a quiet zone size of 30 cm.

Positioning system		
DUT load capability (centered)	on snowflake (standard fixture) ⁵	8 kg, 3GPP alignment option 2
	on clamp (standard fixture) ⁵	1 kg, 3GPP alignment options 1 and 3
	on R&S®CATR-HFIX1 (opt.)	20 kg, 3GPP alignment option 2
DUT dimensions	max.	Ø 520 mm
Distance from surface of DUT fixture to center of rotation in Z-direction	snowflake, clamp	7.5 mm
	R&S®CATR-HFIX1 (opt.)	177.5 mm
DUT connections	on azimuth	1 x USB 3.2
	on azimuth	1 x PC 2.4 mm (m)
Maximum rotating speed	elevation	120°/s
	azimuth	150°/s
Rotating angle	azimuth and elevation	±181°
Angular resolution	azimuth and elevation	0.01°
Accumulated positioner error ⁶	azimuth and elevation with DUT < 5 kg	< 0.1°
	azimuth and elevation with DUT < 20 kg	< 0.2°
Hardware triggering	azimuth or elevation	BNC
	triggering accuracy	< 0.01°
Positioner API		C / C++ / C# / VB.NET / MATLAB®
Feedthroughs		
Pre-installed	communications to DUT	1 x USB 3.2 (USB-B or USB-C)
	communications interface for chamber and positioner control	1 x Ethernet
	hardware trigger output	1 x BNC
	I/Os for external system communications	1 x D-Sub
	used for software update	1 x USB 2.0
Unoccupied feedthroughs available	front, below door	6
	left	2
	right	3
	rear, top	2

Environmental conditions

Temperature range	operating temperature range	+10 °C to +40 °C
	storage temperature range	-10 °C to +50 °C
Damp heat		75 % relative humidity, non-condensing at +10 °C to +40 °C

Product conformity

Electromagnetic compatibility	in line with EU – EMC Directive 2004/108/EC	applied harmonized standards: • EN 61326-1, • EN 55011, group I, class A equipment
Electrical safety	in line with EU – Machine Directive 2006/42/EC	applied harmonized and non-harmonized standards: • EN ISO 12100 • EN 61010-1 • EN 61010-2-120
Restriction of the use of hazardous substances in electrical and electronic equipment	in line with EU – RoHS Directive	applied harmonized standard: EN 50581

R&S®CATR-REFL1 CATR reflector, regular size

Frequency range ⁷		6 GHz to 92 GHz
Quiet zone size		Ø 30 cm
Surface roughness	RMS	< 1 µm
Dimension		54 cm x 56 cm (21.26 in x 22.05 in)

⁵ Additionally available with R&S®CATR-FIX1U or R&S®CATR-FIX2U.

⁶ Measured worst-case scenario (i.e.: positioner at 135°).

⁷ Higher/lower frequencies are possible with higher mean error inside the quiet zone.

R&S®CATR-REFL6 CATR reflector, large size

Frequency range ⁸		6 GHz to 92 GHz
Quiet zone size		Ø 40 cm
Surface roughness	RMS	< 1 µm
Dimension		69 cm x 71 cm (27.17 in x 27.95 in)

R&S®CATR-FE4 OOB feed horn antenna, for CATR system

Frequency range	out-of-band	6 GHz to 25 GHz
Polarization		dual polarized
RF connectors on feedthrough		2 x PC 2.4 mm (f)

R&S®CATR-FE30 feed horn antenna, for CATR system

Frequency range	out-of-band	6 GHz to 35 GHz
Polarization		dual polarized
RF connectors on feedthrough		2 x PC 2.4 mm (f)

R&S®CATR-FE40 feed antenna with OMT, for CATR system

Frequency range	in-band	23.5 GHz to 44.3 GHz
Polarization		dual polarized
RF connectors on feedthrough		2 x PC 1.85 mm (f)

R&S®CATR-FE60 feed antenna with OMT, for CATR system

Frequency range	out-of-band	36.5 GHz to 61 GHz
Polarization		dual polarized
RF connectors on feedthrough		2 x PC 1.85 mm (f)

R&S®CATR-FE90 feed antenna with OMT, for CATR system

Frequency range	out-of-band	59 GHz to 92 GHz
Polarization		dual polarized
RF connectors on feedthrough		2 x PC 1.35 mm (f)

R&S®CATR-TEMP2 extreme temperature condition

DUT load capability	weight, centered	max. 10 kg
Dimensions of DUT	maximum device size (see drawings on page 13)	
	device height up to Ø 410 mm	< 230 mm
	device height up to Ø 350 mm	< 255 mm
	device height up to Ø 140 mm	< 275 mm
Temperature range		-40 °C to +85 °C
Temperature change ⁹	-10 °C to +55 °C (3GPP range)	3 min (meas.)
	+55 °C to -10 °C (3GPP range)	4 min (meas.)
	-40 °C to +85 °C	10 min (meas.)
	+85 °C to -40 °C	14 min (meas.)
Air-in flow volume limits	maximum	700 l/min
Air-in flow temperature limits		-60 °C to +125 °C
Relative humidity range		50 % relative humidity, non-condensing at +10 °C to +40 °C
Controlling software		not provided; the temperature has to be controlled in the external temperature forcing system.
Mechanical interface	air-in thread	½" 14 NPT
Weight		6 kg (13.23 lb)

⁸ Higher/lower frequencies are possible with higher mean error inside the quiet zone.

⁹ Measured at DUT level with 700 l/min flow volume, rate of change may depend on DUT.

R&S®CATR-CAM1 camera option, visual and thermal combined

Image modes		visual, thermal, MSX (IR image with enhanced detail presentation)
		light available
Field of view		48° × 37°
Accuracy	for values from +10 °C to +100 °C	±2 °C (nom.)
Communications interface		Ethernet

R&S®CATR-MIMOA 4x4 MIMO anker

Number of dual polarized antennas		2
Antenna mounting		swivel ball or fixed
Adjustability	in Y-axis, from azimuth rotation center	±200 mm
RF connector	on left rear, outside of chamber	4 × SMA feedthrough (f)

R&S®CATR-RFRJ2 dual RF rotary joint extension on azimuth

Frequency range	port 1	DC to 50 GHz
	port 2	DC to 18 GHz
RF connection on positioner	port 1	2.4 mm (m)
	port 2	2.92 mm (m)
Feedthrough	port 1 (reused from existing chamber)	1.85 mm (f)
	port 2	2.92 mm (f)

R&S®TC-TA50CPR link antenna, ruggedized Vivaldi

Frequency range		650 MHz to 50 GHz
RF connector	incl. RF cable MMPX (m) to 1.85 mm (m), length: 350 mm	MMPX
Impedance		50 Ω
Outer dimensions		7 cm × 3 cm (2.76 in × 1.18 in)

R&S®CATR-MNT2 mounting kit, for rear side mounting of RRH and RF42

Number of mounting plates		2
Maximum number of RRHs	per mounting plate	4 (threads available)
Maximum number of RF42	per mounting plate	1 (threads available)
Hole pattern		30 mm × 30 mm (1.18 in × 1.18 in)
Mounting surface	W × H	630 mm × 480 mm (24.80 in × 18.90 in)
Maximum weight	per mounting plate	20 kg (44.09 lb)

R&S®CATR- HFIX1 phantom fixture or heavy DUT mounting

Maximum DUT weight		20 kg
Maximum DUT size	Ø × H	52 cm × 40 cm (20.47 in × 15.75 in)
Distance to center of rotation		177.5 mm
Alignment options in line with 3GPP standard		alignment option 2

R&S®CATR-FX4 fixed feed holder, for R&S®CATR-FE4

Cable length		300 mm
Connector type		2 × PC 2.4 mm (m)
Attenuation	at 20 GHz	1.1 dB (nom.)
		1.3 dB (nom.)
Number of cables		2

R&S®CATR-FX30 fixed feed holder, for R&S®CATR-FE30

Cable length		300 mm
Connector type		PC 2.92 mm (m) to PC 2.4 mm (m)
Attenuation	at 20 GHz	1.1 dB (nom.)
		1.3 dB (nom.)
Number of cables		2

R&S®CATR-FX40 fixed feed holder, for R&S®CATR-FE40

Cable length		300 mm
Connector type		2 × PC 2.4 mm (m)
Attenuation	at 28 GHz	1.1 dB (nom.)
	at 39 GHz	1.3 dB (nom.)
Number of cables		2

R&S®CATR-FX60 fixed feed holder, for R&S®CATR-FE60

Cable length		300 mm
Connector type		2 × PC 1.85 mm (m)
Attenuation	at 40 GHz	6.0 dB (nom.)
	at 60 GHz	7.6 dB (nom.)
Number of cables		2

CATR-FX90 fixed feed holder, for R&S®CATR-FE90

Cable length		300 mm
Connector type		2 × PC 1.35 mm (m)
Attenuation	at 60 GHz	4.4 dB (nom.)
	at 90 GHz	5.0 dB (nom.)
Number of cables		2

R&S®CATR-FESWA automatic feed switcher

Number of antennas		up to 4 antennas
Switching speed		< 5 s (longest distance)
Positioning accuracy		0.25 mm (nom.)
Repeatability		< 0.1 mm
Stability (switching antennas) ¹⁰	mean amplitude error	< 0.1 dB (meas.)
	mean phase error	±2.5° (meas.)

R&S®CATR-FL4 feed holder, for R&S®CATR-FE4 on automatic feed switcher

Cable length		665 mm
Connector type		2 × PC 1.85 mm (m)
Attenuation	at 20 GHz	4.1 dB (nom.)
Number of cables		2

R&S®CATR-FL30 feed holder, for R&S®CATR-FE30 on automatic feed switcher

Cable length		665 mm
Connector type		PC 2.92 mm (m) to PC 2.4 mm (m)
Attenuation	at 20 GHz	3.7 dB (nom.)
Number of cables		2

R&S®CATR-FL40 feed holder, for R&S®CATR-FE40 on automatic feed switcher

Cable length		585 mm
Connector type		2 × PC 2.4 mm (m)
Attenuation	at 28 GHz	1.848 dB (nom.)
	at 39 GHz	2.2 dB (nom.)
Number of cables		2

¹⁰ Measured with R&S®CATR-FE40 for 23.5 GHz to 44.3 GHz.

R&S®CATR-FL60 feed holder, for R&S®CATR-FE60 on automatic feed switcher

Cable length		665 mm
Connector type		2 × PC 1.85 mm (m)
Attenuation	at 40 GHz	6.0 dB (nom.)
	at 60 GHz	7.6 dB (nom.)
Number of cables		2

R&S®CATR-FL90 feed holder, for R&S®CATR-FE90 on automatic feed switcher

Cable length		585 mm
Connector type		2 × PC 1.35 mm (m)
Attenuation	at 60 GHz	8.6 dB (nom.)
	at 90 GHz	9.8 dB (nom.)
Number of cables		2

R&S®TS-QOQZIB in-band quality of quiet zone assessment fixture kit

General data		
Test sizes		Ø 30 cm, Ø 40 cm
Test plans supported	amplitude QoQZ	TS 38.521-2, CTIA 01.73
	phase QoQZ	CTIA 01.73

Antenna parameters		
Polarization		single polarized
Antenna type		choked horn
Connector type		1 × PC 1.85 mm (f)
Frequency range	in-band	23.5 GHz to 44.3 GHz
HPBW	HPBW-compliant frequencies in line with TS 38.521-2	23.45/24.25/32.0/32.125/40.0/ 40.8/44.3 GHz (meas.)

Fixture parameters		
Number of cables		3
Cable length		800 mm
Connector type		2 × PC 1.85 mm (m)

R&S®CATR-SCML1 left side chamber option, for multiple angle of arrival

Number of reflectors		1
Size	W × H × D	0.9 m × 1.99 m × 1.28 m (35.43 in × 78.35 in × 50.39 in)
Weight		approx. 250 kg (551.16 lb)
Number of installable feed antennas		1
Feedthroughs		2
Amplitude performance ¹¹	average amplitude taper	< 1.5 dB (meas.)
	average amplitude ripple	< 0.5 dB (meas.)
Total phase variation ¹²	at 28 GHz	±7.5° (meas.)
	at 39 GHz	±10° (meas.)

¹¹ Measured from 23.5 GHz to 90 GHz.

¹² From 23.5 GHz to 44.3 GHz.

R&S®CATR-SCMR2 right side chamber option, for multiple angle of arrival

Number of reflectors		2
Size	W x H x D	0.9 m x 1.99 m x 1.28 m (35.43 in x 78.35 in x 50.39 in)
Weight		approx. 250 kg (551.16 lb)
Number of installable feed antennas		2
Feedthroughs		4
Amplitude performance ¹¹	average amplitude taper	< 1.5 dB (meas.)
	average amplitude ripple	< 0.5 dB (meas.)
Total phase variation ¹²	at 28 GHz	±7.5° (meas.)
	at 39 GHz	±10° (meas.)

R&S®CATR-FM4 feed holder, for R&S®CATR-FE4 in side-chamber

Cable length		665 mm
Connector type		2 x PC 1.85 mm (m)
Attenuation	at 20 GHz	2.9 dB (nom.)
Number of cables		2

R&S®CATR-FM30 feed holder, for R&S®CATR-FE30 in side-chamber

Cable length		665 mm
Connector type		PC 2.92 mm (m) to PC 2.4 mm (m)
Attenuation	at 20 GHz	3.7 dB (nom.)
Number of cables		2

R&S®CATR-FM40 feed holder, for R&S®CATR-FE40 in side-chamber

Cable length		700 mm
Connector type		2 x PC 2.4 mm (m)
Attenuation	at 28 GHz	2.53 dB (nom.)
	at 39 GHz	3.00 dB (nom.)
Number of cables		2

R&S®CATR-FM60 feed holder, for R&S®CATR-FE60 in side-chamber

Cable length		665 mm
Connector type		2 x PC 1.85 mm (m)
Attenuation	at 40 GHz	6.0 dB (nom.)
	at 60 GHz	7.6 dB (nom.)
Number of cables		2

R&S®CATR-FM90 feed holder, for R&S®CATR-FE90 in side-chamber

Cable length		585 mm
Connector type		2 x PC 1.35 mm (m)
Attenuation	at 60 GHz	8.6 dB (nom.)
	at 90 GHz	9.8 dB (nom.)
Number of cables		2

Ordering information

Basic configuration

Designation	Type	Order No.
CATR based compact 5G NR mmWave test chamber	R&S®ATS1800C	1534.1800K03
CATR based compact 5G NR mmWave test chamber	R&S®ATS1800C	1534.1800.03
CATR reflector, medium size	R&S®CATR-REFL1	1534.2307.02
Feed antenna with OMT for CATR system, 23 GHz to 44 GHz	R&S®CATR-FE40	1540.6246.02
Fixed feed holder for R&S®CATR-FE40	R&S®CATR-FX40	1540.6346.02
USB 3.2 B-type feedthrough	R&S®TS-F1U3BA1	1537.6632.02

Additional options

Designation	Type	Order No.
USB 3.2 C-type feedthrough	R&S®TS-F1U3CC1	1537.6649.02
CATR reflector, large size	R&S®CATR-REFL6	1540.6500.02
Extreme temperature condition	R&S®CATR-TEMP2	1534.2620.03
Mounting kit, for rear side mounting of RRH and RF42	R&S®CATR-MNT2	1540.6681.02
Camera, visual and thermal view	R&S®CATR-CAM1	1534.2471.03
Fixture, for phantom head or heavy DUT mounting	R&S®CATR-HFIX1	1534.2920.03
4x4 MIMO anker	R&S®CATR-MIMOA	1538.8880.02
Link antenna, ruggedized Vivaldi	R&S®TC-TA50CPR	1531.8633.02
OOB feed horn antenna, for CATR system, 6 GHz to 25 GHz	R&S®CATR-FE4	1540.6223.02
Feed antenna, for CATR system, 6 GHz to 35 GHz	R&S®CATR-FE30	1540.6230.02
Feed antenna with OMT, for CATR system, 40 GHz to 60 GHz	R&S®CATR-FE60	1540.6275.02
Feed antenna with OMT, for CATR system, 60 GHz to 90 GHz	R&S®CATR-FE90	1540.6269.02
Fixed feed holder, for R&S®CATR-FE30	R&S®CATR-FX30	1540.6330.02
Fixed feed holder, for R&S®CATR-FE40	R&S®CATR-FX40	1540.6346.02
Fixed feed holder, for R&S®CATR-FE60	R&S®CATR-FX60	1540.6375.02
Fixed feed holder, for R&S®CATR-FE90	R&S®CATR-FX90	1540.6369.02
Automatic feed switcher	R&S®CATR-FESWA	1540.6600.02
Feed holder, for R&S®CATR-FE4 on automatic feed switcher	R&S®CATR-FL4	1540.6423.02
Fixed feed holder, for R&S®CATR-FE30	R&S®CATR-FL30	1540.6430.02
Feed holder, for R&S®CATR-FE40 on automatic feed switcher	R&S®CATR-FL40	1540.6446.02
Feed holder, for R&S®CATR-FE60 on automatic feed switcher	R&S®CATR-FL60	1540.6475.02
Feed holder, for R&S®CATR-FE90 on automatic feed switcher	R&S®CATR-FL90	1540.6469.02
In-band quality of quiet zone assessment fixture kit	R&S®TS-QOQZIB	1545.4941.02
Left side chamber option, for multiple angle of arrival	R&S®CATR-SCML1	1540.6381.02
Right side chamber option, for multiple angle of arrival	R&S®CATR-SCMR2	1540.6481.02
Feed holder, for R&S®CATR-FE4 mounting inside chamber	R&S®CATR-FM4	1540.6617.02
Feed holder, for R&S®CATR-FE30 mounting inside chamber	R&S®CATR-FM30	1540.6623.02
Feed holder, for R&S®CATR-FE40 mounting inside chamber	R&S®CATR-FM40	1540.6630.02
Feed holder, for R&S®CATR-FE60 mounting inside chamber	R&S®CATR-FM60	1540.6675.02
Feed holder, for R&S®CATR-FE90 mounting inside chamber	R&S®CATR-FM90	1540.6652.02
Fixture for 3GGP alignment options 1 and 3	R&S®CATR-FIX1U	1540.6317.02
Fixture for 3GPP alignment option 2	R&S®CATR-FIX2U	1540.6300.02

Accessories for calibration

Designation	Type	Order No.
SGH calibration/alignment antenna, 26.5 GHz to 40 GHz	R&S®TC-SGH40	1530.8617.02
SGH calibration/alignment antenna, 40 GHz to 60 GHz	R&S®TC-SGH60M	1536.8590.02
SGH calibration/alignment antenna, 60 GHz to 90 GHz	R&S®TC-SGH90M	1536.8454.02
Three-path diode power sensor	R&S®NRP50S	1419.0087.02
USB power sensor cable, length: 5 m	R&S®NRP-ZKU	1419.0658.05

Other accessories

Designation	Type	Order No.
50 GHz cable, length: 1.2 m to 1.85 mm (m to f)	R&S®ATS-C50MF	1535.7977.02
50 GHz cable, length: 0.3 m to 2.4 mm (m to m)	R&S®ATS-C50MM3	3658.4232.02

Drawings

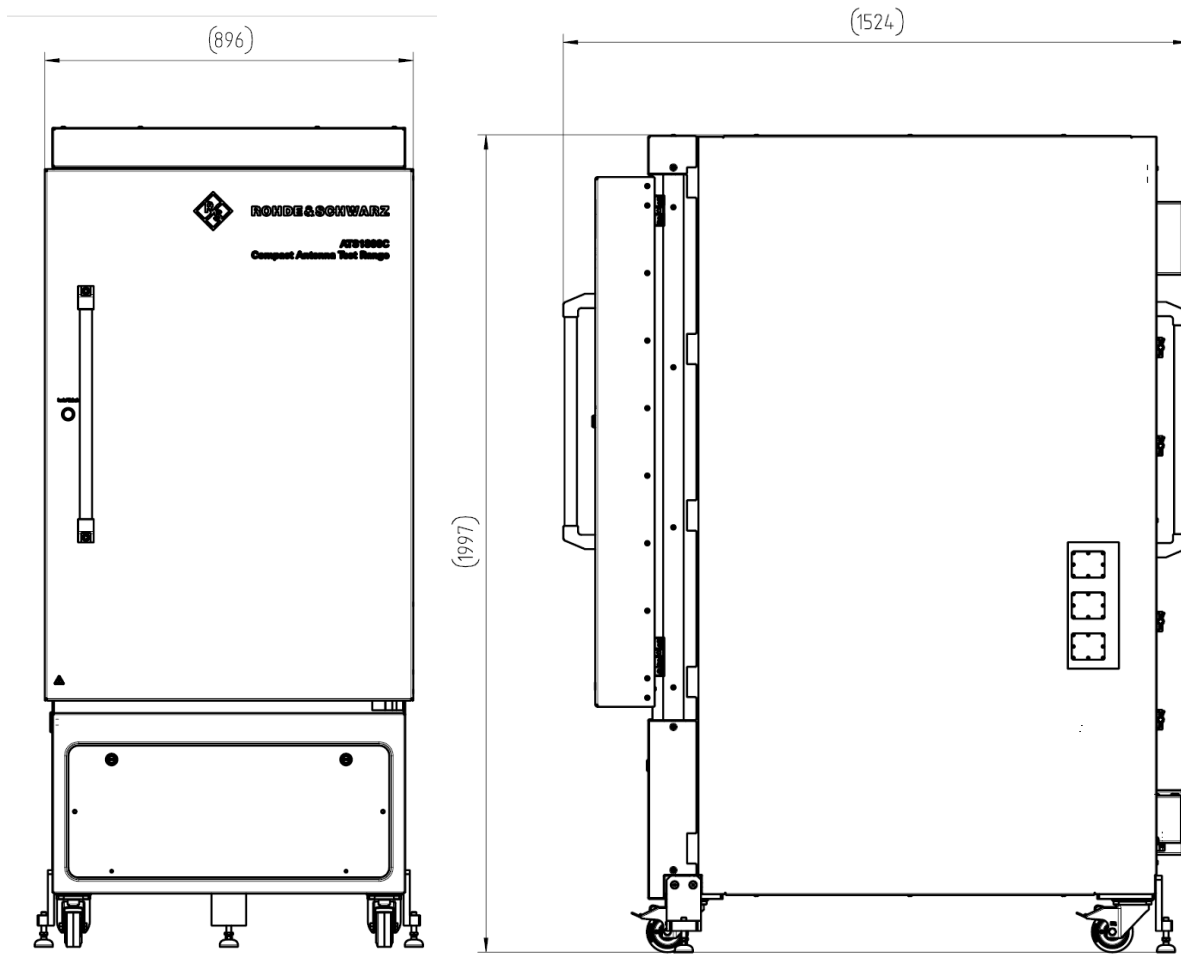

R&S®ATS1800C: front and side view

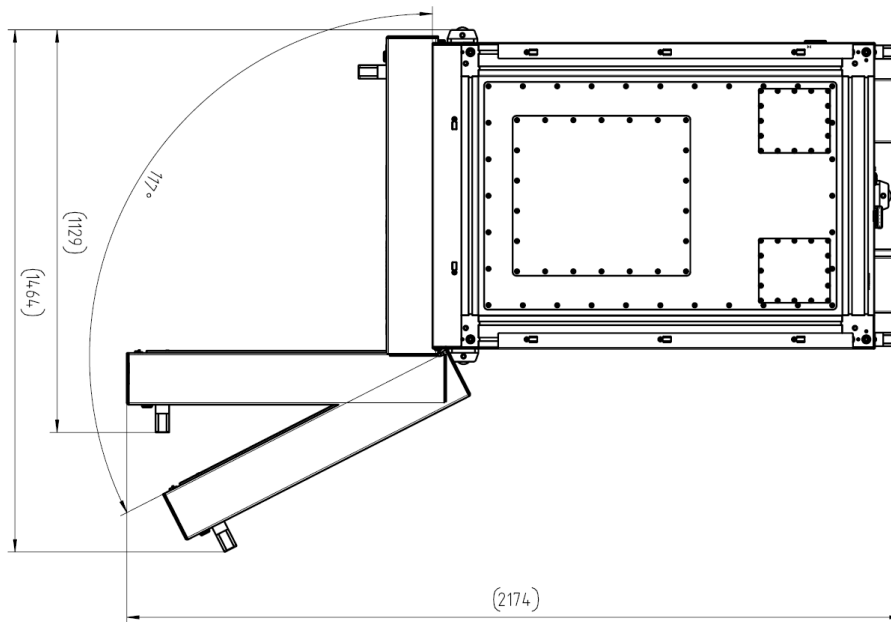

R&S®ATS1800C: top view

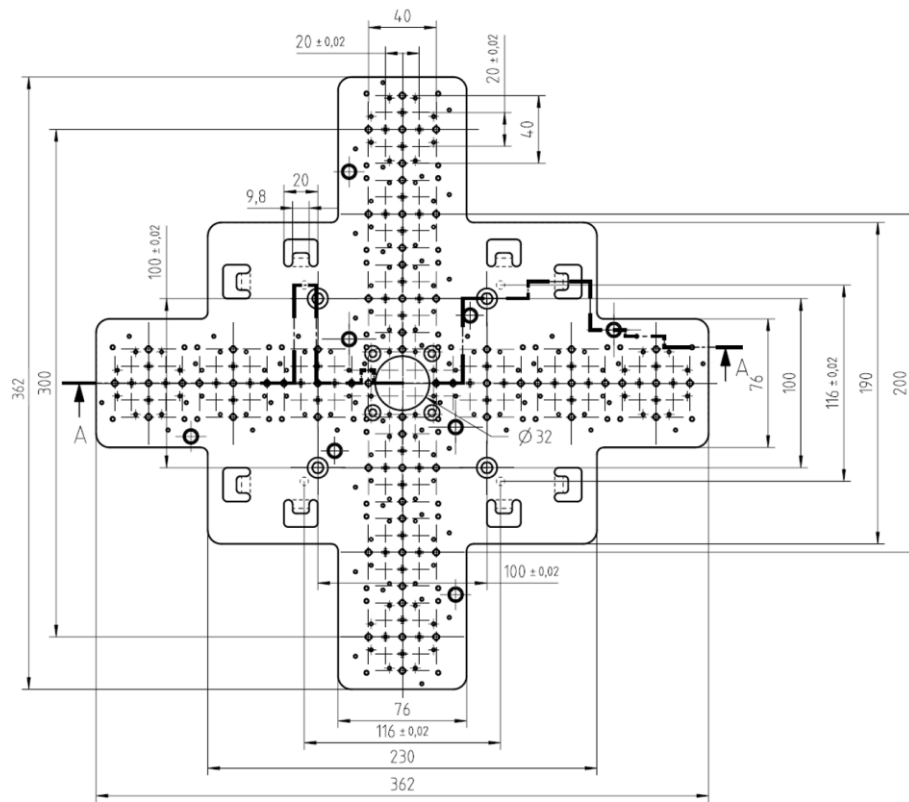

Interface drawing of DUT fixture „Snowflake“ for 30 cm QZ

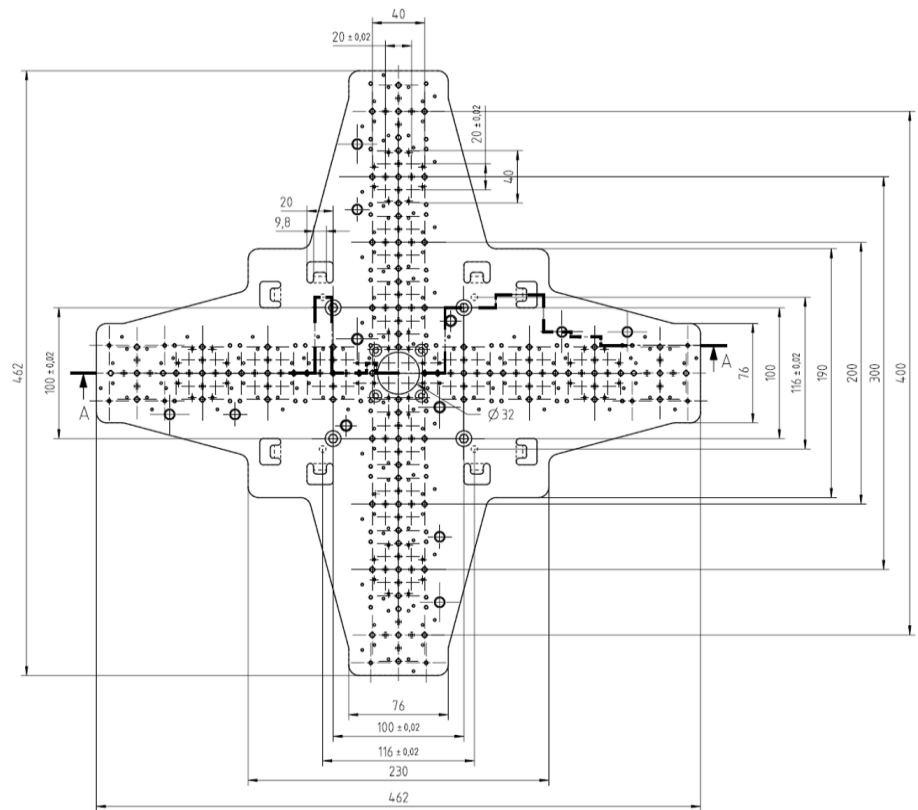

Interface drawing DUT fixture „Snowflake“ for 40 cm QZ

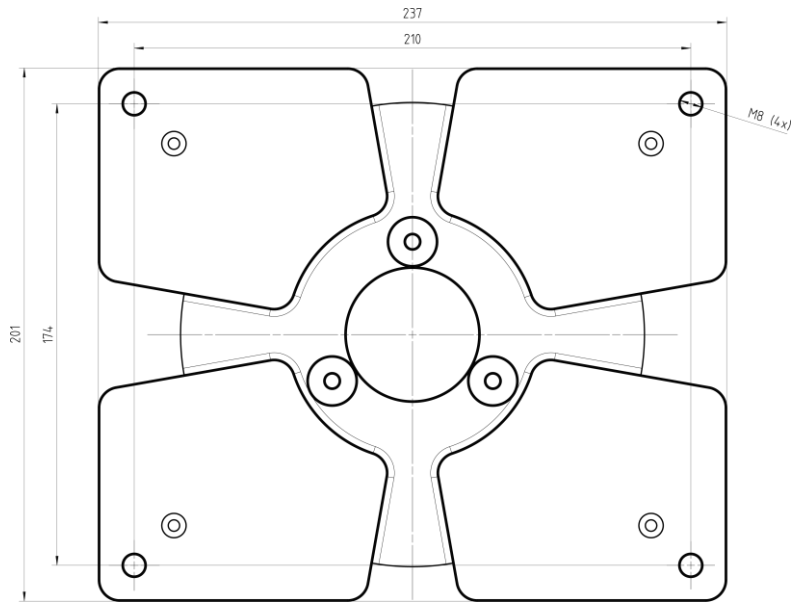

R&S®CATR-HFIX1: interface drawing of DUT fixture

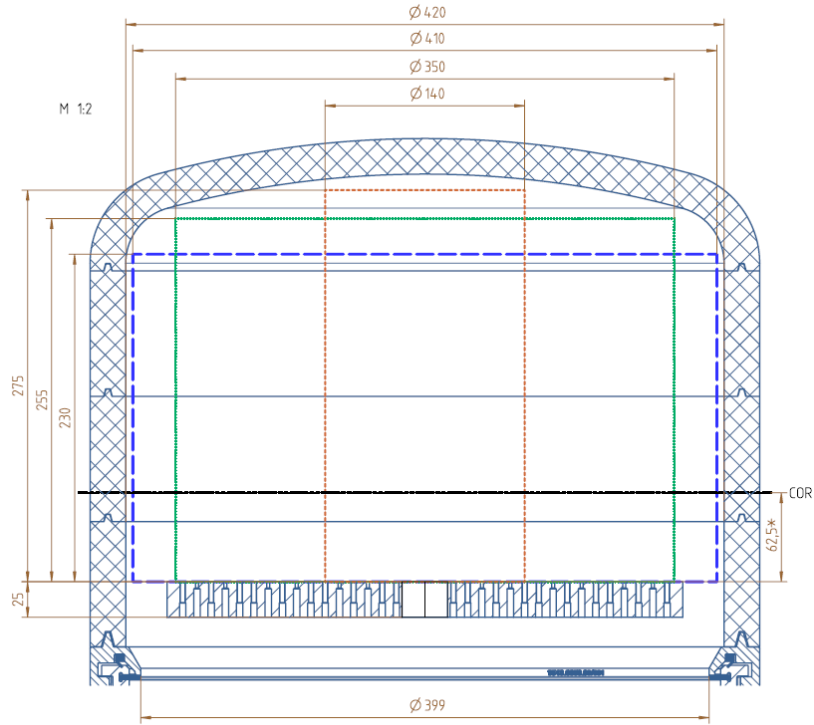

R&S[®]CATR-TEMP2: maximum DUT dimensions, side view

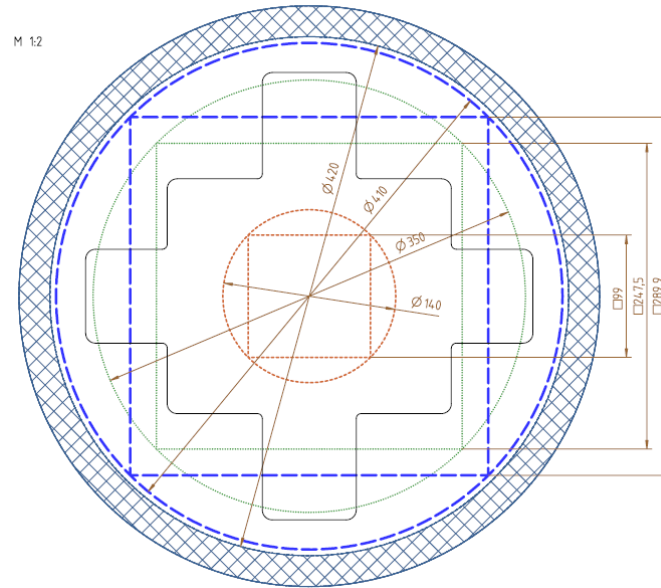

R&S[®]CATR-TEMP2: maximum DUT dimensions, top view

Rohde & Schwarz

The Rohde & Schwarz technology group is among the trailblazers when it comes to paving the way for a safer and connected world with its leading solutions in test & measurement, technology systems and networks & cybersecurity. Founded 90 years ago, the group is a reliable partner for industry and government customers around the globe. The independent company is headquartered in Munich, Germany and has an extensive sales and service network with locations in more than 70 countries.

www.rohde-schwarz.com

Service at Rohde & Schwarz You're in great hands

- ▶ Worldwide
- ▶ Local and personalized
- ▶ Customized and flexible
- ▶ Uncompromising quality
- ▶ Long-term dependability

Sustainable product design

- ▶ Environmental compatibility and eco-footprint
- ▶ Energy efficiency and low emissions
- ▶ Longevity and optimized total cost of ownership

Certified Quality Management

ISO 9001

Certified Environmental Management

ISO 14001

R&S® is a registered trademark of Rohde & Schwarz

Trade names are trademarks of the owners

PD 3683.5251.22 | Version 04.00 | April 2024 (sk)

R&S®ATS1800C Compact 3GPP compliant OTA chamber for 5G NR mmWave signals

Data without tolerance limits is not binding | Subject to change

© 2021 - 2024 Rohde & Schwarz | 81671 Munich, Germany

