

R&S® ATS1500C

ANTENNA TEST CHAMBER FOR AUTOMOTIVE RADAR SENSORS

Specifications



Specifications
Version 08.00

ROHDE & SCHWARZ

Make ideas real



CONTENTS

Definitions	3
Specifications.....	4
Environmental conditions.....	4
Product conformity.....	4
R&S®ATS1500C K02 system performance.....	4
R&S®CATR-REFL1 CATR reflector	5
R&S®TS-F1ETRR1 Ethernet feedthrough.....	5
R&S®TS-F1SD259 D-Sub feedthrough.....	6
R&S®TS-F1POBB2 banana plug feedthrough.....	6
R&S®TS-F1BCBB1 BNC feedthrough.....	6
R&S®TS-F1BCBB2 dual BNC feedthrough.....	6
R&S®TS-F1U2BA1 USB 2.0 feedthrough	6
R&S®ARC-DUTH1 universal DUT holder plate for R&S®ATS1500C	6
R&S®TS-F1WGEE1 WR-12 feedthrough	6
R&S®ARC-F1ARFM feedthrough for R&S®AREG frontend external.....	6
R&S®ARC-FX90 universal feed antenna for R&S®ATS1500C.....	7
R&S®ARC-FX90UP upgrade kit to enable second polarization with R&S®ARC-FX90	7
R&S®CATR-CAM1 camera option, visual and thermal combined.....	7
R&S®ARC-TEMP extreme temperature condition	7
Ordering information	8
Basic configuration	8
Additional options	8
Accessories for alignment and calibration.....	8
Figures	9

Definitions

General

Product data applies under the following conditions:

- Three hours of storage at ambient temperature followed by 30 minutes of warm-up operation
- Specified environmental conditions met
- Recommended calibration interval adhered to
- All internal automatic adjustments performed, if applicable

Specifications with limits

Represent warranted product performance by means of a range of values for the specified parameter. These specifications are marked with limiting symbols such as $<$, \leq , $>$, \geq , \pm , or descriptions such as maximum, limit of, minimum. Compliance is ensured by testing or is derived from the design. Test limits are narrowed by guard bands to take into account measurement uncertainties, drift and aging, if applicable.

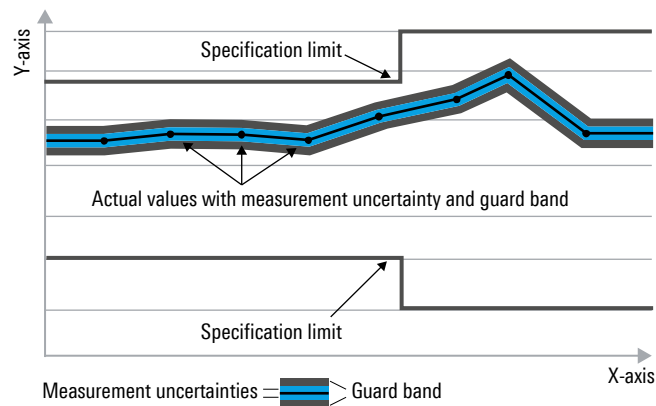

Non-traceable specifications with limits (n. trc.)

Represent product performance that is specified and tested as described under “Specifications with limits” above. However, product performance in this case cannot be warranted due to the lack of measuring equipment traceable to national metrology standards. In this case, measurements are referenced to standards used in the Rohde & Schwarz laboratories.

Specifications without limits

Represent warranted product performance for the specified parameter. These specifications are not specially marked and represent values with no or negligible deviations from the given value (e.g. dimensions or resolution of a setting parameter). Compliance is ensured by design.

Typical data (typ.)

Characterizes product performance by means of representative information for the given parameter. When marked with $<$, $>$ or as a range, it represents the performance met by approximately 80 % of the instruments at production time. Otherwise, it represents the mean value.

Nominal values (nom.)

Characterize product performance by means of a representative value for the given parameter (e.g. nominal impedance). In contrast to typical data, a statistical evaluation does not take place and the parameter is not tested during production.

Measured values (meas.)

Characterize expected product performance by means of measurement results gained from individual samples.

Uncertainties

Represent limits of measurement uncertainty for a given measurand. Uncertainty is defined with a coverage factor of 2 and has been calculated in line with the rules of the Guide to the Expression of Uncertainty in Measurement (GUM), taking into account environmental conditions, aging, wear and tear.

Device settings and GUI parameters are designated with the format “parameter: value”.

Non-traceable specifications with limits, typical data as well as nominal and measured values are not warranted by Rohde & Schwarz.

In line with the 3GPP standard, chip rates are specified in million chips per second (Mcps), whereas bit rates and symbol rates are specified in billion bit per second (Gbps), million bit per second (Mbps), thousand bit per second (kbps), million symbols per second (Msps) or thousand symbols per second (ksps), and sample rates are specified in million samples per second (Msample/s). Gbps, Mcps, Mbps, Msps, kbps, ksps and Msample/s are not SI units.

Specifications

The R&S®ATS1500C is a compact and accurate antenna test chamber for RF testing and validation of gigahertz automotive radar sensor modules. It is based on the principle of a compact antenna test range (CATR) with a reflector, alignment structure and feed antenna.

The R&S®ATS1500C operates with several instruments such as automotive radar echo generators, power sensors, spectrum and signal analyzers as well as signal generators.

Environmental conditions

Temperature range	operating temperature range	+20 °C to +30 °C
	storage temperature range	-10 °C to +50 °C
Damp heat		75 % relative humidity, noncondensing from +10 °C to +30 °C

Product conformity

Electromagnetic compatibility		in line with <ul style="list-style-type: none"> EN 61326-1 EN 55011, group I, class A equipment
EU legislation	EU: in line with Data Act – Regulation (EU) 2023/2854	for details, see user documentation
Electrical safety		in line with <ul style="list-style-type: none"> EN ISO 12100 EN 61010-1 EN 60204-1
Restriction of the use of hazardous substances in electrical and electronic equipment		in line with EN IEC 63000

R&S®ATS1500C K02 system performance

General RF parameters		
Frequency range		18 GHz to 90 GHz ¹
Absorber	frequency range	18 GHz to 110 GHz
	type	pyramidal and flat
	attenuation ²	55 dB (typ.) ³
Reflector	frequency range	6 GHz to 90 GHz
Shielding effectiveness	chamber	> 90 dB (meas.)
Path loss		58 dB (meas.) ⁴
Delay ⁵		8.83 ns (meas.) ⁶

Quality of quiet zone (QZ) ⁷		
Quiet zone size		Ø 30 cm
Amplitude performance ⁸	average amplitude taper	< 1.5 dB (meas.)
	average amplitude ripple	< 0.5 dB (meas.)
Total phase variation	phase taper	< 12° (meas.) ⁹

¹ With R&S®ARC-FX90 from 57 GHz to 90 GHz (from 57 GHz to 60 GHz up to 3 dB higher attenuation).

² For an incident angle of 45° and VHP-4.

³ From 650 MHz to 60 GHz.

⁴ Measured during installation from 60 GHz to 67 GHz.

⁵ Corresponds to 2.65 m air gap.

⁶ With R&S®ARC-FX90, measured during installation, including DUT height of 5 cm.

⁷ In line with IEEE 149-2021.

⁸ Measured at 76.5 GHz.

⁹ Measured at 67 GHz.

Positioning system		
Positioner type		2 axis, tilt-tilt
Angular resolution	resolution of feedback	0.03° (nom.)
Standard deviation positioner error	measure of repeatability	0.02° (meas.)
Tilt angle	outer axis	±180°
	inner axis	±45° ¹⁰
Maximum tilt speed	outer axis	120°/s
	inner axis	15°/s
DUT load capability		4.0 kg, centered
Maximum DUT size		40 cm × 40 cm
DUT fixture plate	dimensions	7.3 cm × 7.3 cm
	thread size	M3 and M4
	adjustable height	5 cm
	stepped manual rotation (orientation of DUT polarization)	22.5°
Hardware triggering	interface	optional (requires BNC feedthrough) ¹¹
	output trigger	trigger on azimuth or elevation
	input trigger	stores azimuth and elevation position
Application programming interfaces		yes (C, C++, C#, VB.NET, Python, MATLAB, ...)
Control		web interface
Controller communications interface		Ethernet
Interfaces on inner axis	right side: communications with DUT	1 × Ethernet, 1 × D-Sub 9-pole, 1 × USB 2.0 (optional)
	left side: power supply via controller	banana jacks (internal supply), 12 V, 2.5 A
	left side: power supply via external power supply	optional (requires banana plugs feedthrough), 48 V, 5 A ¹²

Chamber specifications		
Power consumption		100 V to 120 V/200 V to 240 V (AC), 50 Hz to 60 Hz, max. 5 A
Power plug		C20
Internal power socket outlet	DUT power supply	100 V to 240 V (AC), max. 1 A
Weight		460 kg (1014.13 lb)
Dimensions ¹³	W × H × D	0.90 m × 1.99 m × 1.53 m (35.43 in × 78.35 in × 60.24 in)
Wheels	lockable	4
Door operation		manually operated, electrical closing mechanism
Ventilation rate		45 m ³ /h (meas.)
Noise level		38 dB(A) (nom.)

R&S® CATR-REFL1 CATR reflector

Frequency range ¹⁴		6 GHz to 90 GHz
Quiet zone size		Ø 30 cm
Surface roughness	RMS	< 1 µm
Dimensions		54 cm × 56 cm (21.26 in × 22.05 in)

R&S® TS-F1ETRR1 Ethernet feedthrough

Feedthrough type		1 × Gigabit Ethernet
Functionality	rear side	3D positioner control
	side panel	DUT communications

¹⁰ If the R&S®ARC-TEMP option is installed: ±15°.

¹¹ Output trigger requires 1 × BNC, input and output trigger requires 2 × BNC.

¹² Limited by the banana plugs feedthrough.

¹³ Dimensions include all mounts and handle bars attached with the chamber for depth. If an optional banana plugs feedthrough is mounted, width is extended by 16 mm.

¹⁴ Higher/lower frequencies are possible with higher mean error inside the quiet zone.

R&S®TS-F1SD259 D-Sub feedthrough

Feedthrough type		1 × D-Sub 9-pole, 1 × D-Sub 25-pole
Functionality	side panel	DUT communications ¹⁵

R&S®TS-F1POBB2 banana plug feedthrough

Feedthrough type		1 × banana plug
Functionality		DC power supply for DUT
Power supply	maximum voltage	48 V
	maximum current	5 A

R&S®TS-F1BCBB1 BNC feedthrough

Feedthrough type		1 × BNC
Functionality	rear side	trigger output, 5 V TTL

R&S®TS-F1BCBB2 dual BNC feedthrough

Feedthrough type		2 × BNC
Functionality	rear side	trigger input and output, 5 V TTL

R&S®TS-F1U2BA1 USB 2.0 feedthrough

Feedthrough type		1 × USB 2.0
Functionality	side panel	DUT communications

R&S®ARC-DUTH1 universal DUT holder plate for R&S®ATS1500C

Maximum DUT size		Ø 30 cm
Material		colorless polycarbonate
Thickness		6 mm
Accessories		clamping brackets

R&S®TS-F1WGEE1 WR-12 feedthrough

Waveguide designator	Electronic Industries Alliance (EIA)	WR-12
Connector type	anti-cocking flange	precision waveguide flange compatible with UG387/U-M
Functionality	rear side	interface to connect general purpose radar target simulator
	additional target distance	< 20 mm

R&S®ARC-F1ARFM feedthrough for R&S®AREG frontend external

Feedthrough type		1 × R&S®AREG frontend external
Functionality	rear side	interface to connect R&S®AREG100A/ R&S®AREG800A frontend outside the chamber, when used in combination with R&S®ARC-FX90 universal feed antenna

¹⁵ Only via D-Sub, 9-pole.

R&S®ARC-FX90 universal feed antenna for R&S®ATS1500C

In-band frequency range ¹		60.0 GHz to 90.0 GHz
Polarization	feed antenna	vertical or horizontal polarization possible by changing WR-12 interface
Antenna type and gain		OMT with small corrugated horn antenna 10 dBi (nom.) ¹⁶
	insertion loss ¹⁷	1.5 dB (typ.) at 60 GHz to 81 GHz

R&S®ARC-FX90UP upgrade kit to enable second polarization with R&S®ARC-FX90

In-band frequency range		60.0 GHz to 90.0 GHz
Polarization		vertical and horizontal polarization possible ¹⁸
Functionality	additional radar target distance ¹⁹	< 1 m
	insertion loss ²⁰	1.5 dB (typ.) at 60 GHz to 81 GHz

R&S®CATR-CAM1 camera option, visual and thermal combined

Image modes		visual, thermal, MSX (IR image with enhanced detail presentation)
Field of view		48° × 37°
Accuracy	for values from +10 °C to +100 °C ²¹	±2 °C (nom.)
Communications interface		Ethernet, 100 Mbps
Power supply		power over Ethernet, PoE IEEE 802.3af, class 0

R&S®ARC-TEMP extreme temperature condition ²²

DUT load capability	weight, centered	max. 4 kg
Dimensions of DUT	maximum device size ²³	
	device height up to Ø 375 mm	< 135 mm
	device height up to Ø 150 mm	< 170 mm
Temperature range		-40 °C to +85 °C
Temperature change, dynamic ²⁴	-10 °C to +55 °C	4 min (meas.)
	+55 °C to -10 °C	5 min (meas.)
	-40 °C to +85 °C	15 min (meas.)
	+85 °C to -40 °C	25 min (meas.)
Air-in flow volume recommended		400 l/min
Air-in flow temperature limits		-60 °C to +125 °C
Relative humidity range		50 % relative humidity, noncondensing at +10 °C to +40 °C
Controlling software		not provided; The temperature has to be controlled in the external temperature forcing system.
Mechanical interface	air-in thread	½" 14 NPT
Movement range restriction for positioning system		
Inner axis		max. ±15°
Outer axis		max. ±90°

¹⁶ Only one polarization is routed to the chamber feedthrough.

¹⁷ Maximum 3.5 dB over frequency range from 57 GHz to 90 GHz.

¹⁸ Two polarizations are routed to the chamber feedthroughs.

¹⁹ Depending on polarization and type of feedthrough and in combination with R&S®ARC-FX90.

²⁰ Maximum 3.5 dB over frequency range from 57 GHz to 90 GHz and in combination with R&S®ARC-FX90.

²¹ Environment temperature from +10 °C to +35 °C.

²² The R&S®ARC-TEMP option may only be installed by our service team, either on site or at the Rohde & Schwarz factory.

²³ See drawings beginning on page 9.

²⁴ Measured at 500 l/min.

Ordering information

Basic configuration

Designation	Type	Order No.
Antenna test chamber for automotive radar sensors	R&S®ATS1500C	1537.9777K02
Antenna test chamber for automotive radar sensors	R&S®ATS1500C	1537.9777.02
CATR reflector	R&S®CATR-REFL1	1534.2307.02
Ethernet feedthrough	R&S®TS-F1ETRR1	1525.8729.02
D-Sub feedthrough	R&S®TS-F1SD259	1525.8835.02

Additional options

Designation	Type	Order No.
Banana plug feedthrough	R&S®TS-F1POBB2	1536.0353.02
BNC feedthrough	R&S®TS-F1BCBB1	1533.4070.02
Dual BNC feedthrough	R&S®TS-F1BCBB2	1533.4070.03
USB 2.0 feedthrough	R&S®TS-F1U2BA1	1525.8735.02
Universal DUT holder plate, for R&S®ATS1500C	R&S®ARC-DUTH1	1536.0282.02
WR-12 feedthrough	R&S®TS-F1WGEE1	1541.8607.02
Feedthrough, for R&S®AREG frontend external	R&S®ARC-F1ARFM	1541.8594.02
Universal feed antenna, for R&S®ATS1500C incl. holder	R&S®ARC-FX90	1541.8613.02
Upgrade kit, to enable second polarization in combination with R&S®ARC-FX90 universal feed antenna	R&S®ARC-FX90UP	1543.1200.02
Camera option, visual and thermal view	R&S®CATR-CAM1	1534.2471.02
Extreme temperature condition	R&S®ARC-TEMP	1541.8588.02

Accessories for alignment and calibration

Designation	Type	Order No.
SGH calibration/alignment antenna, 50 GHz to 75 GHz	R&S®TC-SGH75M	1536.8460.04
SGH calibration/alignment antenna, 60 GHz to 90 GHz	R&S®TC-SGH90M	1536.8454.02
Three-path diode power sensor, 100 pW to 200 mW, 10 MHz to 18 GHz	R&S®NRP18S	1419.0029.02
Three-path diode power sensor, 100 pW to 100 mW, 50 MHz to 90 GHz	R&S®NRP90S	1424.6421.03
Thermal power sensor, 300 nW to 100 mW, 60 GHz to 90 GHz	R&S®NRP90TWG	1700.2312.02
USB power sensor cable, length: 5 m	R&S®NRP-ZKU	1419.0658.05
Fixture for reflector alignment	R&S®CATR-FIX2U	1540.6300.02

Figures

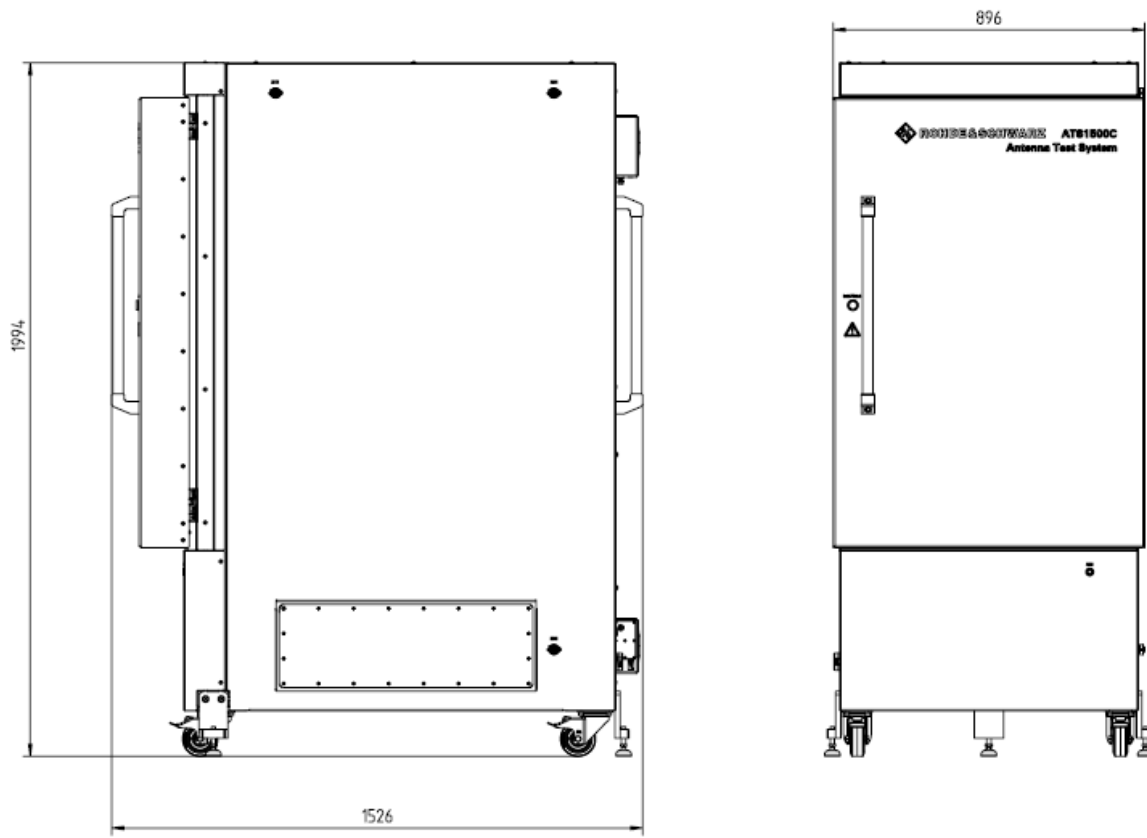

R&S®ATS1500C: front and side view

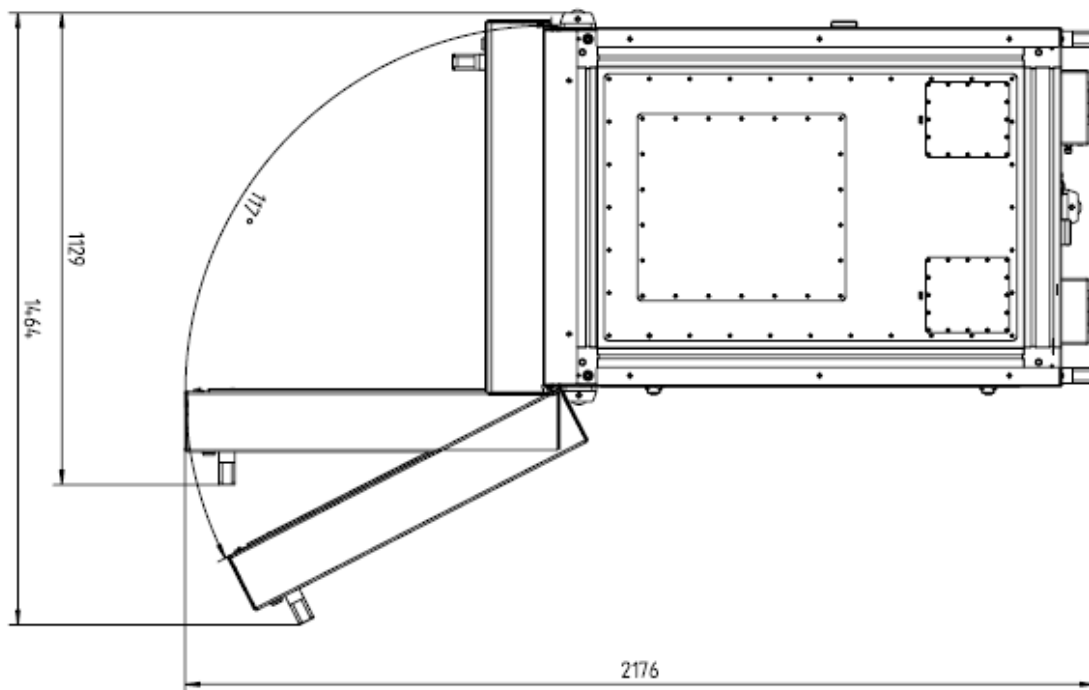

R&S®ATS1500C: top view

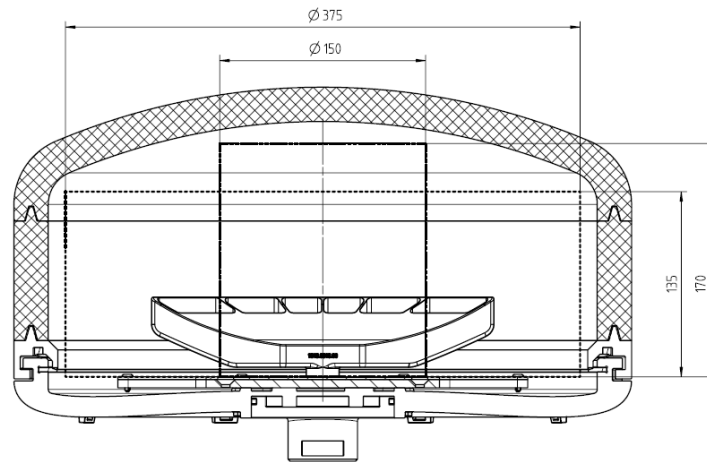

R&S®ARC-TEMP: maximum DUT dimensions, side view

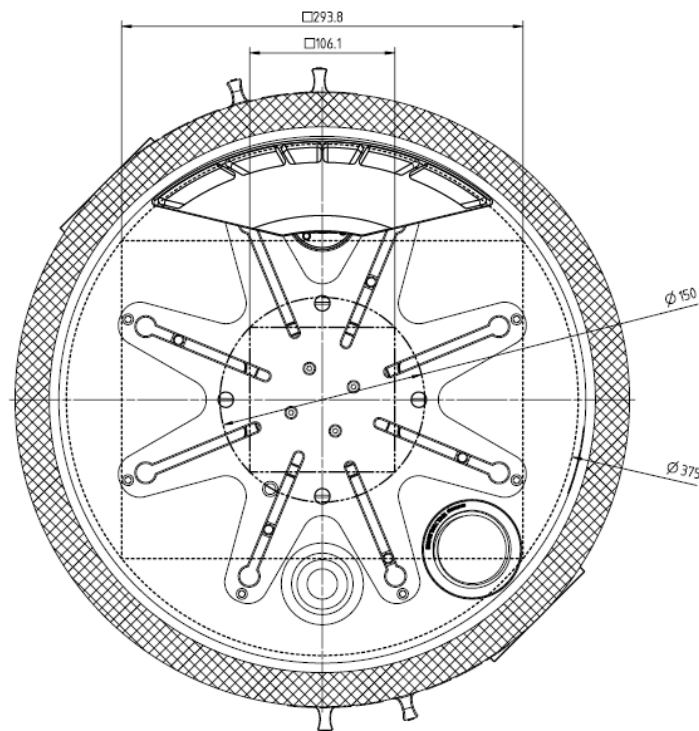

R&S®ARC-TEMP: maximum DUT dimensions, top view

Service at Rohde & Schwarz
You're in great hands

- ▶ Worldwide
- ▶ Local and personalized
- ▶ Customized and flexible
- ▶ Uncompromising quality
- ▶ Long-term dependability

Rohde & Schwarz

The Rohde & Schwarz technology group is among the trailblazers when it comes to paving the way for a safer and connected world with its leading solutions in test & measurement, technology systems and networks & cybersecurity. Founded more than 90 years ago, the group is a reliable partner for industry and government customers around the globe. The independent company is headquartered in Munich, Germany and has an extensive sales and service network with locations in more than 70 countries.

www.rohde-schwarz.com

Sustainable product design

- ▶ Environmental compatibility and eco-footprint
- ▶ Energy efficiency and low emissions
- ▶ Longevity and optimized total cost of ownership

Certified Quality Management

ISO 9001

Certified Environmental Management

ISO 14001

More Rohde & Schwarz certificates



Rohde & Schwarz training

www.training.rohde-schwarz.com

Rohde & Schwarz customer support

www.rohde-schwarz.com/support

