

## Technical Information



## Calibration Units

**R&S® ZV-Z58**

1164.0638.78 / 1164.0638.38

**R&S® ZV-Z59**

1164.0450.36

Printed in Germany



© 2018 Rohde & Schwarz GmbH & Co KG

81671 Munich, Germany

Printed in Germany - Subject to change

R&S® is a registered trademark of Rohde & Schwarz GmbH & Co. KG.

Trade names are trademarks of the owners.

The following abbreviations are used throughout this manual:

R&S® ZVT is abbreviated as R&S ZVT, R&S® ZV-Z58 and R&S® ZV-Z59 are abbreviated as R&S ZV-Z58 and R&S ZV-Z59

# Safety Instructions

## Instrucciones de seguridad

## Sicherheitshinweise

## Consignes de sécurité

---

### **WARNING**

#### **Risk of injury and instrument damage**

The instrument must be used in an appropriate manner to prevent electric shock, fire, personal injury or instrument damage.

- Do not open the instrument casing.
  - Read and observe the "Basic Safety Instructions" delivered as printed brochure with the instrument.
  - Read and observe the safety instructions in the following sections. Note that the data sheet may specify additional operating conditions.
  - Keep the "Basic Safety Instructions" and the product documentation in a safe place and pass them on to the subsequent users.
- 

### **ADVERTENCIA**

#### **Riesgo de lesiones y daños en el instrumento**

El instrumento se debe usar de manera adecuada para prevenir descargas eléctricas, incendios, lesiones o daños materiales.

- No abrir la carcasa del instrumento.
  - Lea y cumpla las "Instrucciones de seguridad elementales" suministradas con el instrumento como folleto impreso.
  - Lea y cumpla las instrucciones de seguridad incluidas en las siguientes secciones. Se debe tener en cuenta que las especificaciones técnicas pueden contener condiciones adicionales para su uso.
  - Guarde bien las instrucciones de seguridad elementales, así como la documentación del producto, y entréguelas a usuarios posteriores.
-

---

**⚠️ WARNUNG****Gefahr von Verletzungen und Schäden am Gerät**

Betreiben Sie das Gerät immer ordnungsgemäß, um elektrischen Schlag, Brand, Verletzungen von Personen oder Geräteschäden zu verhindern.

- Öffnen Sie das Gerätegehäuse nicht.
  - Lesen und beachten Sie die "Grundlegenden Sicherheitshinweise", die als gedruckte Broschüre dem Gerät beiliegen.
  - Lesen und beachten Sie die Sicherheitshinweise in den folgenden Abschnitten; möglicherweise enthält das Datenblatt weitere Hinweise zu speziellen Betriebsbedingungen.
  - Bewahren Sie die "Grundlegenden Sicherheitshinweise" und die Produktdokumentation gut auf und geben Sie diese an weitere Benutzer des Produkts weiter.
- 

---

**⚠️ AVERTISSEMENT****Risque de blessures et d'endommagement de l'appareil**

L'appareil doit être utilisé conformément aux prescriptions afin d'éviter les électrocutions, incendies, dommages corporels et matériels.

- N'ouvrez pas le boîtier de l'appareil.
  - Lisez et respectez les "consignes de sécurité fondamentales" fournies avec l'appareil sous forme de brochure imprimée.
  - Lisez et respectez les instructions de sécurité dans les sections suivantes. Il ne faut pas oublier que la fiche technique peut indiquer des conditions d'exploitation supplémentaires.
  - Gardez les consignes de sécurité fondamentales et la documentation produit dans un lieu sûr et transmettez ces documents aux autres utilisateurs.
-

# Contents

## Remark on R&S ZV-Z58 and R&S ZV-Z59 Units

### Safety Instructions

- 1 Preparing for Use ..... 7**
  - Front Panel.....7**
    - STANDBY Key .....8
    - USB Connector .....8
    - RF Connectors .....8
  - Rear Panel .....9**
  - Putting the Unit into Operation .....10**
    - Unpacking the Unit and Checking the Shipment ..... 10
    - Setting up the Unit..... 10
    - Mounting in a 19" Rack ..... 12
    - EMI Protective Measures ..... 12
    - Connecting the Unit to the AC Supply ..... 12
    - Power on and off ..... 12
    - Standby and Ready State ..... 13
    - Replacing Fuses ..... 13
  - Maintenance .....14**
    - Storing and Packing ..... 14
- 2 Automatic Calibration ..... 15**
  - USB Connection to the Network Analyzer .....15**
  - Performing an Automatic Calibration .....16**
  - Accuracy Considerations .....17**
- Index .....18**

## Remark on R&S ZV-Z58 and R&S ZV-Z59 Units

The two calibration units R&S ZV-Z58 and R&S ZV-Z59 have been designed for different port numbers and frequency ranges.

- The calibration unit R&S ZV-Z58 provides eight ports and covers a frequency range up to 8 GHz. This unit is particularly suited for use with an R&S ZVT8 vector network analyzer. Models 1164.0638.78 and 1164.0638.38 are equipped with type N and 3.5 mm connectors, respectively.
- The calibration unit R&S ZV-Z59 provides six ports and covers a frequency range up to 20 GHz. This unit is particularly suited for use with an R&S ZVT20 vector network analyzer. The unit is equipped with 3.5 mm connectors.

Unless otherwise stated, all information in the remainder of this document applies to both calibration units.

# Safety Instructions

This calibration unit has been designed and tested in accordance with the EC Certificate of Conformity and has left the manufacturer's plant in a condition fully complying with safety standards.

## CAUTION



### General safety instructions

To maintain this condition and to ensure safe operation, you must observe all instructions and warnings given on this page and in Chapter 1 of this technical information.

Please notice in particular the instructions below on this page.

## USB Connection to the Analyzer

- The calibration unit is intended for direct connection to network analyzers of the R&S® ZVAB family following the procedure described in Chapters 1 and 2 and in the analyzer's help system. Do not connect the unit to other USB hosts, e.g. a PC, or insert any USB hubs between the analyzer and the unit, as this may cause damage to the unit or the host.
- You can connect several calibration units to the different USB ports of the analyzer. You can also connect cal units and other devices (mouse, USB memory stick etc.) simultaneously.
- An unused calibration unit may remain connected to the USB port while the network analyzer is performing measurements. It must be disconnected during a firmware update.
- It is safe to connect or disconnect the calibration unit while the network analyzer is operating. Never connect or disconnect the unit while data is being transferred between the analyzer and the unit. Never connect the unit during a firmware update.

## ESD Protective Measures

To protect the calibration unit against Electrostatic Discharge (ESD) damage use the wrist strap and grounding cord supplied with the network analyzer and connect yourself to the GND connector at the front panel. For details refer to the Quick Start Guide of your analyzer.

## RF Connection

The maximum RF input power of the calibration unit is beyond the RF output power range of the analyzer, so there is no risk of damage if the device is directly connected to the test ports. If you use an external power amplifier, make sure that the maximum RF input power of the calibration unit quoted in the data sheet is never exceeded.

# 1 Preparing for Use

This chapter gives an overview of the front panel controls and connectors of the R&S ZV-Z58 and R&S ZV-Z59 calibration units and gives all information that is necessary to put the units into operation and connect external devices.

## CAUTION General safety instructions



Please observe the instructions of the following sections so that you cannot endanger people or cause damage to the unit. This is of particular importance when you use the unit for the first time. Also observe the general safety instructions at the beginning of this manual.

Chapter 2 provides an introduction to the operation of the calibration unit. For further information including remote control reference refer to the online help system of your network analyzer or its printed/printable version delivered on CD-ROM. A more detailed description of the hardware connectors and interfaces is also part of the help system.

## Front Panel

The front panel of the calibration unit provides the STANDBY key, a USB type B connector, and 8 RF connectors representing the calibration ports of the unit.





## STANDBY Key

The *STANDBY* toggle switch connects or disconnects all internal modules of the calibration unit from the secondary supply voltage generated by its internal power supply; see section [Standby and Ready State](#) on p. 13 ff.



It is recommendable to switch the calibration unit to standby state or switch it off by the rear panel AC power switch if it is not used for some time.

## USB Connector

Universal Serial Bus connector of type B (slave USB), used to control the unit from a R&S ZVB / R&S ZVA / R&S ZVT network analyzer.



### USB connection

The length of the connecting USB cable should not exceed 1 m. It is recommended to use the cable delivered with the calibration unit. See also section [USB Connection to the Network Analyzer](#) starting on p. 15.

## RF Connectors

Type N connectors (R&S ZV-Z58 calibration unit variant 78) or 3.5 mm connectors (R&S ZV-Z58 calibration unit variant 38 or R&S ZV-Z59 calibration unit) numbered 1 to 8 (6), to be connected to arbitrary test ports of the analyzer. See section [Accuracy Considerations](#) starting on p. 16.



**ATTENTION Maximum RF input power**

The maximum RF input power of the calibration unit is beyond the RF output power range of the analyzer, so there is no risk of damage if the device is directly connected to the test ports.

If you use an external power amplifier, make sure that the maximum RF input power of the calibration unit quoted in the data sheet is never exceeded.

## Rear Panel

The rear panel contains the mains connector with the AC power switch and a fuse holder. See section [Power on and off](#) starting on p. 12.



## Putting the Unit into Operation

This section describes the basic steps to be taken when setting up the calibration unit for the first time.

### ATTENTION Ambient conditions



Before turning on the unit, please make sure that the following conditions are fulfilled:

- Unit covers are in place and all fasteners are tightened.
- Fan openings are unobstructed.
- The unit is dry and shows no condensation.

Non-observance may cause damage to the unit!

## Unpacking the Unit and Checking the Shipment

1. Unpack the unit and the other contents of the shipping container.
2. Check the shipment against the list of accessories to ensure that all items are included.
3. Remove the two protective caps from the front and rear and carefully inspect the calibration unit to make sure that it was not damaged during shipment.

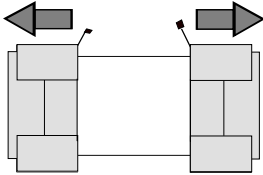

Should the unit be damaged, immediately notify the forwarder who shipped the unit to you and keep the container and packing material.

Equipment returned or sent in for repair must be packed in the original container or packing with electrostatic protection. It is recommended to keep at least the two protective caps for front and rear side in order to prevent damage to the controls and connectors.

## Setting up the Unit

The calibration unit is designed for use under laboratory conditions, either on a bench top or in a rack. The general ambient conditions required at the operating site are as follows:

- The ambient temperature must be in the ranges specified for operation and for compliance with specifications (see data sheet).
- All fan openings including the rear panel perforations must be unobstructed. The distance to the wall should be at least 10 cm.

**ATTENTION Electrostatic discharge**

To avoid damage of electronic components of the DUT and the calibration unit, the operating site must be protected against electrostatic discharge (ESD). ESD is most likely to occur when you connect or disconnect the calibration unit's test ports.

To prevent ESD damage use the wrist strap and grounding cord supplied with the unit and connect yourself to the GND connector at the front panel.

**Bench Top Operation**

If the calibration unit is operated on a bench top, the surface should be flat.

The unit must be used in horizontal position, standing on its feet. It is also possible to place the unit on top of the calibrated network analyzer; see figure in section [Performing an Automatic Calibration](#) starting on p. 16.

**WARNING Danger of injury**

The feet may fold in if they are not folded out completely or if the instrument is shifted. The feet may break if they are overloaded.

Fold the feet completely in or completely out to ensure stability of the instrument and personal safety. To avoid injuries, never shift the instrument when its feet are folded out. The overall load (the instrument's own weight plus that of the instruments stacked on top of it) on the folded-out feet must not exceed 500 N.

Place the instrument on a stable surface. Secure the instruments stacked on top of it against slipping (e.g. by locking their feet on the top front frame). When the instrument is standing on its folded-out feet, do not work under the instrument and do not put anything under it, otherwise injuries or material damage could occur.

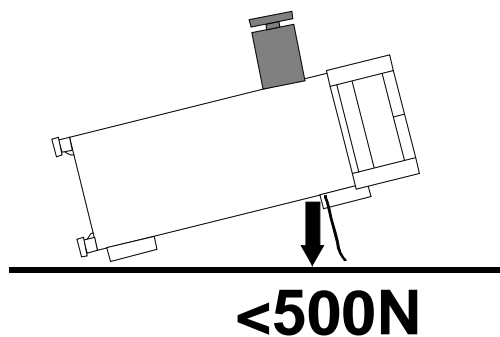

The instrument can be used in each of the positions shown here.

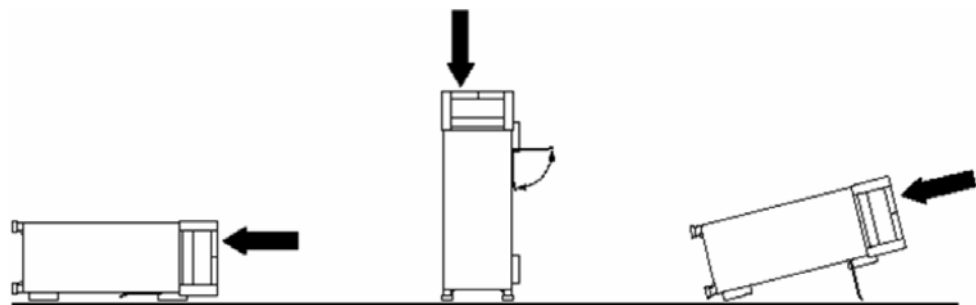

## Mounting in a 19" Rack

Using the adapter ZZA-211 (order number 1096.3260.00) the unit can be mounted in 19" racks according to the mounting instructions supplied with the rack adapter.

### ATTENTION Operation in a rack



- Allow for sufficient air supply in the rack.
- Make sure that there is sufficient space between the ventilation holes and the rack casing.

## EMI Protective Measures

In order to avoid electromagnetic interference, the unit may only be operated when it is closed and with all shielding covers fitted. Only appropriate shielded signal and control cables may be used.

### ATTENTION Electrostatic discharge



To protect the calibration unit against Electrostatic Discharge (ESD) damage use the wrist strap and grounding cord supplied with the network analyzer and connect yourself to the GND connector at the front panel. For details refer to the Quick Start Guide of your analyzer.

## Connecting the Unit to the AC Supply

The calibration unit is automatically adapted to the AC supply voltage supplied. The supply voltage must be in the range 100 V to 240 V; 50 Hz to 60 Hz. The mains connector is located at the rear panel.

- ▶ Connect the calibration unit to the AC power source using the AC power cable delivered with the unit.

The maximum power consumption of the calibration unit is 125 W. The typical power consumption is listed in the data sheet. The calibration unit is protected by two fuses which can be replaced as described in section [Replacing Fuses](#) on page 13.

## Power on and off

The mains connector is located at the rear panel.

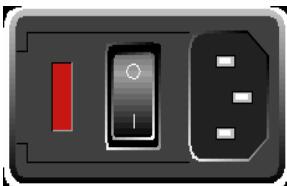

- ▶ To turn the power on or off, press the AC power switch to position I (On) or 0 (Off).

After power-on, the calibration unit is in standby or ready state, depending on the state of the *STANDBY* toggle switch at the front panel of the unit.



#### AC power switch

The AC power switch can be permanently on. Switching off is required only if the unit must be completely removed from the AC power supply.

## Standby and Ready State

The *STANDBY* toggle switch connects or disconnects all internal modules of the calibration unit from the secondary supply voltage generated by its internal power supply.

- In *standby* state the power consumption of the calibration unit is very small, however, the internal power supply is still connected to the AC mains power as long as the mains power switch at the rear panel is on.
- In *ready* state all modules are power-supplied and the calibration unit can be used as described in section [Automatic Calibration](#) on p. 15 ff.



It is recommendable to switch the calibration unit to standby state or switch it off by the rear panel AC power switch if it is not used for some time.

- ▶ After switching on the AC power, press the *STANDBY* key to switch the calibration unit from the standby to ready state or vice versa.

#### CAUTION

#### Shock hazard



The unit is still power-supplied while it is in standby mode.

## Replacing Fuses

The mains connector at the rear panel is protected by two fuses IEC127 T3.15 H.

- ▶ To replace the fuses carefully open the lid from the left side and remove the red fuse holder from its shaft. If needed, use a small screwdriver for lifting the fuse holder.

## Maintenance

The unit does not require any special maintenance. Make sure that the air vents are not obstructed. The outside of the instrument is suitably cleaned using a soft, line-free dust cloth.

---

**ATTENTION**    **Instrument damage caused by cleaning agents**

Cleaning agents contain substances that may damage the instrument, e.g. solvent-containing cleaning agents may damage the front panel labeling or plastic parts. Never use cleaning agents such as solvents (thinners, acetone, etc), acids, bases, or other substances.

---

For our support center address and a list of useful R&S contact addresses refer to the pages at the beginning of this manual.

## Storing and Packing

The unit can be stored at the temperature range quoted in the data sheet. When it is stored for a longer period of time the instrument should be protected against dust.

The original packing should be used, particularly the [protective caps](#) at the front and rear, when the instrument is to be transported or dispatched. If the original packing is no longer available, use a sturdy cardboard box of suitable size and carefully wrap the instrument to protect it against mechanical damage.

## 2 Automatic Calibration

The calibration unit is an integrated solution for automatic system error calibration of vector network analyzers of the R&S ZVAB family with 1 to 8 ports. It is especially suited for the 8-port vector network analyzers R&S ZVT. The unit contains calibration standards that are electronically switched when a calibration is performed. The calibration kit data for the internal standards is also stored in the calibration unit, so that the analyzer can calculate the error terms and apply the calibration without any further input.

Automatic calibration is generally faster and more secure than manual calibration:

- There is no need to connect several standards manually. The number of connections to be performed quickly increases with the number of ports.
- Invalid calibrations due to operator errors (e.g. wrong standards or improper connections) are almost excluded.
- No need to handle calibration kit data.
- The internal standards do not wear out because they are switched electronically.



### Contents of this Technical Information

This Technical Information gives a brief introduction to the unit's connection and use. For detailed information refer to the help system of your network analyzer.

## USB Connection to the Network Analyzer

The calibration unit provides the following connectors:

- A USB type B connector at the front panel is used to control the unit. A USB cable for connection to the network analyzer is provided with the calibration unit.
- Eight or six RF connectors numbered 1 to 8 (6) are to be connected to the test ports of the analyzer. The two alternative R&S ZV-Z59 cal unit models 1164.0638.38 and 1164.0638.78 are equipped with 3.5 mm (f) or type N (f) sockets, respectively. The R&S ZV-Z59 cal unit provides 3.5 mm sockets.

### To connect the unit...

1. Switch on and start-up your network analyzer.
2. Wear a grounded wrist strap; see [EMI Protective Measures](#) on p. 12 ff.
3. Connect the USB type A connector of the USB cable to any of the USB type A connectors on the front or rear panel of the analyzer and the USB type B connector of the USB cable to the USB type B connector on the front panel of the calibration unit. You can also connect the unit before switching on the analyzer.
4. Wait until the operating system has recognized and initialized the new hardware. When the unit is connected for the first time, this may take longer than in normal use.

The unit is ready to be used as outlined below.



## Performing an Automatic Calibration

After connection and initialization, you can use the calibration unit as follows:

1. Connect ports  $n$  analyzer ports ( $n = 1$  to  $8$  (6), depending on your analyzer and cal unit model and the number of ports to be calibrated) to  $n$  arbitrary ports of the calibration unit. Terminate all unused ports (no.  $n + 1$  to  $8$ ) with a  $50 \Omega$  match.
2. Perform the automatic calibration for the selected number of ports using the *Measurement Wizard* or the *Start Calibration* menu. For details refer to the analyzer's help system.
3. Remove the test cables from the unit, connect your DUT instead and perform calibrated measurements.



### Tip for Cabling

The cabling of test ports is easiest if the calibration unit is placed on top of the analyzer; see figure below.



## Accuracy Considerations

To ensure an accurate calibration, please observe the following items:

- Unused ports of the calibration unit must be terminated with a 50  $\Omega$  match.
- No adaptors must be inserted between the calibration unit and the test ports.
- After connecting the unit to the USB port, allow for a sufficient warm-up time (see data sheet) before starting the calibration.
- To ensure best accuracy the analyzer automatically reduces the source power to –10 dBm. If the test setup contains a large attenuation, deactivate *Automatic Power Reduction for Calibration Unit* in the initial tab of the *System Config* dialog and ensure an input power of –10 dBm at the ports of the calibration unit (please also refer to the data sheet).

The calibration type depends on the number of ports. If a single port is calibrated, the analyzer uses full one port calibration. For 2 and more ports, TOSM calibration is used.

# Index

## A

AC power .....	12
Accuracy considerations .....	17
Automatic calibration .....	15

## B

Bench top operation .....	11
---------------------------	----

## C

Calibration (procedure) .....	16
-------------------------------	----

## E

EMI .....	12, 15
Equipment supplied .....	10

## F

Front panel .....	7
Front view .....	7
Fuses (replace) .....	13

## I

Instrument setup .....	10
------------------------	----

## K

Key .....	8
STANDBY .....	8

## M

Maintenance .....	14
-------------------	----

## P

Power on/off .....	9, 12
Preparing for use .....	7

## R

R&S ZV-Z58 .....	4
R&S ZV-Z59 .....	4
Rack (mounting) .....	12
Rear panel .....	9
Replacing	
Fuses .....	13
RF connectors .....	8

## S

Standby .....	8, 13
STANDBY Key .....	8
Storing the instrument .....	14

## U

USB connection .....	8, 15
USB connector .....	8

## Z

ZV-Z58 .....	4
ZV-Z59 .....	4