

# R&S® TS-PI02

## Analog/Digital IO Module 2

### User Manual



1506720812  
Version 07

**ROHDE & SCHWARZ**  
Make ideas real



This manual describes the following R&S®TSVP module:

- R&S®TS-PIO2

© 2022 Rohde & Schwarz GmbH & Co. KG  
Muehldorfstr. 15, 81671 Muenchen, Germany  
Phone: +49 89 41 29 - 0  
Email: [info@rohde-schwarz.com](mailto:info@rohde-schwarz.com)  
Internet: [www.rohde-schwarz.com](http://www.rohde-schwarz.com)  
Subject to change – data without tolerance limits is not binding.  
R&S® is a registered trademark of Rohde & Schwarz GmbH & Co. KG.  
Trade names are trademarks of the owners.

1506.7208.12 | Version 07 | R&S®TS-PIO2

The following abbreviations are used throughout this manual: R&S®TS-PIO2 is abbreviated as R&S TS-PIO2.

# Contents

<b>1</b>	<b>Safety information (multilingual)</b>	<b>5</b>
<b>2</b>	<b>Documentation overview</b>	<b>9</b>
2.1	Getting started manual	9
2.2	User manuals	9
2.3	System manual	10
2.4	Service manual	10
2.5	Printed safety instructions	10
2.6	Brochures and specifications	10
2.7	Release notes and open source acknowledgment	10
<b>3</b>	<b>Welcome to the R&amp;S TS-PIO2</b>	<b>11</b>
<b>4</b>	<b>Module tour</b>	<b>13</b>
4.1	R&S TS-PIO2	13
4.1.1	Status LEDs	13
4.1.2	Connectors X1 and X20	13
4.1.3	Connector X10	14
4.1.4	Connector X30	14
4.2	R&S TS-PDC	14
4.2.1	Status LEDs	15
4.2.2	Connector X20	16
<b>5</b>	<b>Installing the module</b>	<b>17</b>
<b>6</b>	<b>Function description</b>	<b>18</b>
6.1	R&S TS-PIO2	18
6.1.1	General	18
6.1.2	Application examples	20
6.1.3	Signal wiring	23
6.1.4	Using sense lines	27
6.1.5	Adjusting current limiting	27
6.1.6	Output of static voltages	27
6.1.7	Output of static digital bit patterns	27
6.1.8	Output of dynamic digital bit patterns	28

6.1.9	Output of arbitrary waveforms.....	28
6.1.10	Output of square wave signals.....	28
6.1.11	Recording digital measurement values.....	29
6.1.12	Voltage measurements.....	29
6.1.13	Triggering and sequence control.....	30
6.1.14	Generating trigger signals.....	31
6.1.15	Autocorrection.....	32
6.1.16	Excess temperature protection.....	32
<b>6.2</b>	<b>R&amp;S TS-PDC.....</b>	<b>33</b>
<b>7</b>	<b>Software.....</b>	<b>34</b>
<b>7.1</b>	<b>Driver software.....</b>	<b>34</b>
<b>7.2</b>	<b>Soft panel.....</b>	<b>34</b>
<b>7.3</b>	<b>Sample program R&amp;S TS-PIO2.....</b>	<b>37</b>
<b>8</b>	<b>Maintenance, storage and disposal.....</b>	<b>42</b>
<b>8.1</b>	<b>Storage.....</b>	<b>42</b>
<b>8.2</b>	<b>Disposal.....</b>	<b>42</b>
<b>9</b>	<b>Troubleshooting.....</b>	<b>43</b>
<b>9.1</b>	<b>LED test.....</b>	<b>43</b>
<b>9.2</b>	<b>Power-on test.....</b>	<b>43</b>
<b>9.3</b>	<b>R&amp;S TSVP self-test.....</b>	<b>44</b>
<b>9.4</b>	<b>Contacting customer support.....</b>	<b>44</b>
	<b>Annex.....</b>	<b>45</b>
<b>A</b>	<b>Specifications.....</b>	<b>45</b>
<b>B</b>	<b>Block diagrams.....</b>	<b>46</b>
<b>C</b>	<b>Interface description.....</b>	<b>49</b>
<b>C.1</b>	<b>R&amp;S TS-PIO2.....</b>	<b>49</b>
C.1.1	Connector X1.....	49
C.1.2	Connector X20.....	50
C.1.3	Connector X10.....	51
C.1.4	Connector X30.....	53
<b>C.2</b>	<b>R&amp;S TS-PDC.....</b>	<b>54</b>

# 1 Safety information (multilingual)

This option or accessory is designed for a specific Rohde & Schwarz product. Multilingual safety information is delivered with the product. Follow the provided installation instructions.

Esta opción o este accesorio están diseñados para un producto Rohde & Schwarz concreto. El producto va acompañado de información de seguridad en varios idiomas. Siga las instrucciones de instalación puestas a disposición.

Diese Option oder dieses Zubehör ist für ein bestimmtes Rohde & Schwarz Produkt vorgesehen. Mit dem Produkt werden mehrsprachige Sicherheitsinformationen geliefert. Befolgen Sie die mitgelieferten Installationsanweisungen.

Cette option ou cet accessoire est conçu pour un produit Rohde & Schwarz spécifique. Des informations de sécurité multilingues sont fournies avec le produit. Suivez les instructions d'installation fournies.

Questa funzione opzionale o accessoria è progettata per un prodotto Rohde & Schwarz specifico. Con il prodotto sono fornite informazioni sulla sicurezza in formato multilingue. Seguire le istruzioni di installazione allegate.

Esta(e) opção ou acessório foi concebida(o) para um produto específico da Rohde & Schwarz. Serão fornecidas informações de segurança multilingues com o produto. Siga as instruções de instalação fornecidas.

Αυτή η προαιρετική επιλογή ή εξάρτημα έχει σχεδιαστεί για συγκεκριμένο προϊόν Rohde & Schwarz. Μαζί με το προϊόν παρέχονται πληροφορίες ασφαλείας σε πολλές γλώσσες. Ακολουθήστε τις παρεχόμενες οδηγίες εγκατάστασης.

Din l-għażla jew aċċessorju huma mfassla għal prodott Rohde & Schwarz speċifiku. L-informazzjoni multilingwi dwar is-sikurezza hija pprovduta mal-prodott. Segwi l-istruzzjonijiet ipprovduti għall-installazzjoni.

Deze optie of dit accessoire is ontwikkeld voor een specifiek product van Rohde & Schwarz. Het product wordt geleverd met veiligheidsinformatie in meerdere talen. Volg de meegeleverde installatie-instructies.

Denne mulighed eller tilbehørsdel er designet til et specifikt Rohde & Schwarz produkt. En flersproget sikkerhedsanvisning leveres sammen med produktet. Følg de medfølgende installationsanvisninger.

Detta tillval eller tillbehör är avsett för en särskild produkt från Rohde & Schwarz. Säkerhetsinformation på flera språk medföljer produkten. Följ de medföljande installationsanvisningarna.

Tämä vaihtoehto tai lisävaruste on suunniteltu tietyille Rohde & Schwarz -yrietyksen tuotteelle. Tuotteen mukana on toimitettu monikieliset turvallisuusohjeet. Noudata annettuja asennusohjeita.

Dette alternativet eller ekstrautstyret er utformet for et spesifikt Rohde & Schwarz produkt. Flerspråklig sikkerhetsinformasjon leveres med produktet. Overhold installasjonsveiledningen som følger med.

See valik või lisaseade on mõeldud konkreetsele Rohde & Schwarz tootele. Tootega on kaasas mitmekeelne ohutusteave. Järgige kaasasolevaid paigaldusjuhiseid.

Št opcija vai piederums ir izstrādāts īpaši Rohde & Schwarz produktam. Produktam pievienota drošības informācija vairākās valodās. Ievērojiet sniegtos uzstādīšanas norādījumus.

Ši parinktis ar priedas skirti konkrētam Rohde & Schwarz gaminiui. Su gaminiu pateikiama saugos informācijas keliomis kalbomis. Laikykitės pateikiamų montavimo nurodymų.

Þessi auka- eða fylgibúnaður er hannaður fyrir tiltekna Rohde & Schwarz vöru. Öryggisupplýsingar á mörgum tungumálum fylgja með vörunni. Fylgið meðfylgjandi uppsetningarleiðbeiningum.

Tá an rogha nó an oiriúint seo ceaptha le haghaidh táirge Rohde & Schwarz sonrach. Cuirtear eolas sábháilteachta ilteangach ar fáil leis an táirge. Lean na treoracha suiteála a thugtar.

Эта опция или принадлежность предназначена для конкретного продукта Rohde & Schwarz. В комплект поставки продукта входят инструкции по технике безопасности на нескольких языках. Соблюдайте прилагаемые инструкции по установке.

Ця опція або приладдя призначені для конкретного виробу Rohde & Schwarz. Інструкції з техніки безпеки кількома мовами постачаються разом із виробом. Дотримуйтеся наданих інструкцій зі встановлення.

Ta opcja lub akcesorium jest przeznaczona do określonego produktu Rohde & Schwarz. Dostarczany produkt zawiera informacje w wielu językach dotyczące bezpieczeństwa. Należy postępować zgodnie z dostarczonymi instrukcjami instalacji.

Tato varianta nebo příslušenství je určeno pro konkrétní produkt Rohde & Schwarz. S produktem jsou dodávány vícejazyčné bezpečnostní informace. Řiďte se příloženými pokyny k instalaci.

Táto verzia alebo príslušenstvo je navrhnutá pre špecifický výrobok Rohde & Schwarz. S výrobkom sa dodávajú viacjazyčné bezpečnostné pokyny. Riadte sa dodanými pokynmi na inštaláciu.

Ta možnost ali dodatek je zasnovan za določen izdelek podjetja Rohde & Schwarz. Izdelku so priložena varnostna navodila v več jezikih. Upoštevajte priložena navodila za namestitev.

Ezt a beállítást vagy tartozékot egy adott Rohde & Schwarz termékhez tervezték. A termékhez többnyelvű biztonsági információt mellékelünk. Kövesse a mellékelt szerelési utasításokat.

Тази опция или аксесоар са проектирани за специфичен продукт на Rohde & Schwarz. Многоезикова информация за безопасност се доставя с продукта. Следвайте предоставените инструкции за монтаж.

Ova opcija ili oprema namijenjena je za određeni proizvod tvrtke Rohde & Schwarz. Uz proizvod su dostavljene sigurnosne napomene na više jezika. Pratite isporučene upute za ugradnju.

Ova opcija ili pribor je dizajniran za određeni Rohde & Schwarz proizvod. Proizvodu su priložene sigurnosne informacije na više jezika. Slijedite priložena uputstva za instalaciju.

Ova opcija ili dodatni pribor je projektovan za određeni Rohde & Schwarz proizvod. Bezbednosne informacije na više jezika se isporučuju uz proizvod. Sledite dostavljena uputstva za instalaciju.

Această opțiune sau acest accesoriu a fost conceput pentru un produs specific Rohde & Schwarz. Informațiile multilingve privind siguranța sunt livrate împreună cu produsul. Urmați instrucțiunile de instalare furnizate.

Ky opsion ose aksesori është krijuar për një produkt specifik Rohde & Schwarz. Bashkë me produktin jepen edhe informacionet e sigurisë në shumë gjuhë. Ndiqni udhëzimet e dhëna të instalimit.

Оваа опција или додаток се наменети за одреден производ на Rohde & Schwarz. Со производот се испорачани повеќејазични безбедносни упатства. Следете ги дадените упатства за инсталација.

Bu opsiyon veya aksesuar, belirli bir Rohde & Schwarz ürünü için tasarlanmıştır. Çok dilli güvenlik uyarıları ürünle birlikte teslim edilir. Size sağlanan kurulum talimatlarına uyun.

אפשרות זו או האביזר מיועדים למוצר ספציפי של Rohde & Schwarz. מידע רב-לשוני בנושא בטיחות מצורף למוצר. יש לפעול בהתאם להנחיות ההתקנה המצורפות.

تم تصميم هذا الخيار أو الملحق لمنتج معين من منتجات Rohde & Schwarz. يتم تزويد معلومات السلامة متعددة اللغات مع المنتج. اتبع تعليمات التركيب الموضحة.

این قابلیت یا وسیله جانبی منحصرأ برای محصول به خصوص Rohde & Schwarz طراحی شده است. اطلاعات ایمنی چندزبانه همراه این دستگاه ارائه شده است. دستورالعمل‌های نصب ارائه شده را دنبال کنید.

اسن اختیار یا حصے کو مخصوص Rohde & Schwarz پروڈکٹ کے لئے تیار کیا گیا ہے۔ پروڈکٹ کے ساتھ کثیر السانی زبانوں میں تحفظ کی معلومات فراہم کی جاتی ہیں۔ فراہم کردہ تنصیب کی ہدایات پر عمل کریں۔

Šu opsiya ýa-da esbap Rohde & Schwarz anyk önüm üçin niýetlenilen. Dürli dildäki howpsuzlyk barada maglumat önüm bilen bile üpjün edilýär. Üpjün edilen gurnama ugrukdymalaryny ýerine ýetiriň.

इस विकल्प या एक्सेसरी को एक विशेष Rohde & Schwarz उत्पाद के लिए डिज़ाइन किया गया है. उत्पाद के साथ बहुभाषी सुरक्षा जानकारी दी जाती है. प्रदान किए गए इंस्टालेशन अनुदेशों का पालन करें.

本选项或附件专门设计用于特定的 Rohde & Schwarz 产品。产品随附多种语言版本的安全资讯。谨遵文件中的安装说明。

本オプションアクセサリは、特定の Rohde & Schwarz 製品向けに設計されています。多言語で記載された安全情報が製品に付属します。付属のインストール手順に従ってください。

이 옵션 또는 액세서리는 특정 Rohde & Schwarz 제품용으로 설계되었습니다. 제품과 함께 다국어로 작성된 안전 정보가 제공됩니다. 함께 제공된 설치 지침을 따르십시오.

本選配或配件專門設計用於特定的 Rohde & Schwarz 產品。產品隨附多種語言版本的安全資訊。遵守文件中的安裝說明。

Tùy chọn hoặc phụ kiện này dành riêng cho một sản phẩm Rohde & Schwarz cụ thể. Thông tin an toàn đa ngôn ngữ được cung cấp kèm theo sản phẩm. Thực hiện theo hướng dẫn lắp đặt kèm theo.

ตัวเลือกหรืออุปกรณ์เสริมนี้ออกแบบมาสำหรับผลิตภัณฑ์ Rohde & Schwarz โดยเฉพาะ โดยจะมีการจัดส่งข้อมูลด้านความปลอดภัยหลายภาษามาให้พร้อมกับผลิตภัณฑ์ ปฏิบัติตามคำแนะนำในการติดตั้งที่ให้ไว้

Pilihan atau aksesoris ini direka bentuk untuk produk Rohde & Schwarz yang tertentu. Maklumat keselamatan berbilang bahasa disertakan bersama produk. Ikut arahan pemasangan yang diberikan.

Opsi atau aksesoris ini dirancang untuk produk Rohde & Schwarz tertentu. Informasi keamanan dalam beberapa bahasa juga disertakan bersama produk. Ikuti petunjuk pemasangan yang disediakan.

Esta opción o este accesorio están diseñados para un producto Rohde & Schwarz en concreto. El producto va acompañado de información de seguridad en varios idiomas. Siga las instrucciones de instalación proporcionadas con el producto.

Esta opção ou acessório foi desenvolvido para um produto Rohde & Schwarz específico. Informações de segurança em vários idiomas acompanham o produto. Siga as instruções de instalação disponibilizadas.



## 2 Documentation overview

This section provides an overview of the R&S TSVP (test system versatile platform) user documentation.

All documents are delivered with the Generic Test Software Library ("R&S GTSL") installation package. After installing the software, you can open all the documentation from the Windows "Start" menu. Additionally, you can find detailed information about the software interfaces in the "R&S GTSL Help" folder in the Windows "Start" menu.

The user documentation and "R&S GTSL" installation package are also available for download in GLORIS at:

<https://gloris.rohde-schwarz.com/>

For details, see the R&S TSVP Getting Started manual.

### 2.1 Getting started manual

Introduces the R&S TSVP (test system versatile platform) and describes how to set up and start working with the product. It includes safety information.

A printed version is delivered with the instrument.

### 2.2 User manuals

Separate manuals are provided for the base units, the individual plug-in module types, as well as for the control software and the calibration tool:

- Base unit manual  
The base unit user manuals introduce the base units and describes how to set up and operate the product. It includes safety information and information on maintenance and instrument interfaces. It includes the contents of the getting started manual.
- Plug-in module manuals  
Contain the description of the specific modules. Basic information on setting up the R&S TSVP (test system versatile platform) is not included.
- In-System calibration user manuals  
Provide all the information required for installation and operation of the in-system calibration R&S TS-ISC solution.
- Control software
  - R&S GTSL  
Generic Test Software Library
  - R&S EGTSL  
Enhanced Generic Test Software Library
  - R&S IC-Check

## Generic Test Software Library

### 2.3 System manual

Describes the complete R&S TSVP (test system versatile platform) as a whole, including the combined use of R&S CompactTSVP and R&S PowerTSVP, plug-in modules and generic test software. It also includes typical use cases.

Additionally, it describes known installation problems (hardware and software) along with possible solutions.

### 2.4 Service manual

Describes the self-test to check correct operation, troubleshooting and fault elimination, and contains mechanical drawings and spare part lists.

### 2.5 Printed safety instructions

Provides safety information in many languages. The printed document is delivered with the product.

### 2.6 Brochures and specifications

Separate brochures are provided for the base unit, the individual plug-in module types, as well as for the control software. The brochures provide an overview of the base units and each additional module, and also contain the technical specifications. They also list the hardware options and their order numbers, and optional accessories.

### 2.7 Release notes and open source acknowledgment

The release notes list new features, improvements and known issues of the current software version. In addition, the available firmware versions and the firmware update procedure for plug-in modules are described.

The open-source acknowledgment document provides verbatim license texts of the used open source software.

## 3 Welcome to the R&S TS-PIO2

The Analog/Digital IO Module R&S TS-PIO2 can be operated on the R&S TSVP test platforms. The card receives its ground-free power supply from a Rear-I/O module of type R&S TS-PDC. The R&S TS-PIO2 is controlled by the CAN bus present in the base units.

The R&S TS-PIO2 module provides 16 combined analog / digital input channels and 16 combined analog / digital output channels. The channels are arranged in groups of four. The last output channel in each group has special properties. These include a enhanced accuracy, adjustable current limiting, a higher maximum output current and the capability of using sense lines. Some of the settings for a channel can be made channel-specifically or group-specifically (the same for all channels in a group). Each channel also provides the user with a 100-Ohm precision resistor with contact available via the front side connector.

Each of the 16 output channels can be operated in the one of the following operating modes:

- Analog output
- Digital static output
- Digital dynamic output
- Arbitrary waveform
- Square wave

All 16 input channels are wired to comparators and also to the input of an analog/digital converter. The limits of the comparators are adjustable. This makes the following evaluations of a signal possible:

- Voltage measurements against module ground
- Differential voltage measurements between two channels
- Digital evaluation

Timing control of bit sampling and measurement data recording as well as output of digital bit patterns and analog arbitrary waveform values run in parallel for all IO channels through a central sequence control. Four memory units with a depth of 5000 values each are available on the module for digital and analog inputs and outputs. The sequence control can be started by various trigger sources. The sampling interval can be adjusted in a range from 200  $\mu$ s to 1 sec.

The output channels can generate a square wave independently of sequence control. The level, frequency, and duty cycle are also adjustable.

Inputs and outputs can also be flexibly connected via relays. Each output can be connected to either the front side connector or the corresponding input. The inputs of each channel can also be connected to the front side connector or the TSVP analog bus.

Features of the R&S TS-PIO2

- Potential-free
- 16 input channels and 16 output channels
- Output voltage range  $\pm 27$  V

- Input voltage range  $\pm 7$  V,  $\pm 14$  V,  $\pm 28$  V
- Maximum output current for the 12 standard channels 25 mA, 100 mA for the extended channels
- Sense lines and programmable current limiting for the extended channels
- Differential voltage measurement (optional)
- High accuracy; resolution 24 bits
- Maximum sampling rate during measurement and update rate for output 5 kHz
- Memory for 4 x 5000 values (analog and digital measurement values; digital bit pattern and arbitrary waveform output)
- Access to analog bus
- Trigger options via PXI trigger bus
- Self-test capability
- Soft Panel for interactive operation
- LabWindows/CVI driver available

#### Features of the R&S TS-PDC

The R&S TS-PDC module is used as a floating DC voltage source for the R&S TS-PIO2 module. It is configured with two identical DC/DC converters. The following floating direct voltages are obtained from an input voltage of 5 VDC:

- +15 VDC  $\pm 5\%$ , 0,5 A (2x)
- -15 VDC  $\pm 5\%$ , 0,5 A (2x)
- +5 VDC  $\pm 5\%$ , 0,5 A (2x)
- +3,3 VDC  $\pm 5\%$ , 0,25 A (2x)

## 4 Module tour

### 4.1 R&S TS-PIO2

The Analog/Digital IO Module R&S TS-PIO2 is designed as a long plug-in module for mounting in the front of a R&S TSVP base unit.

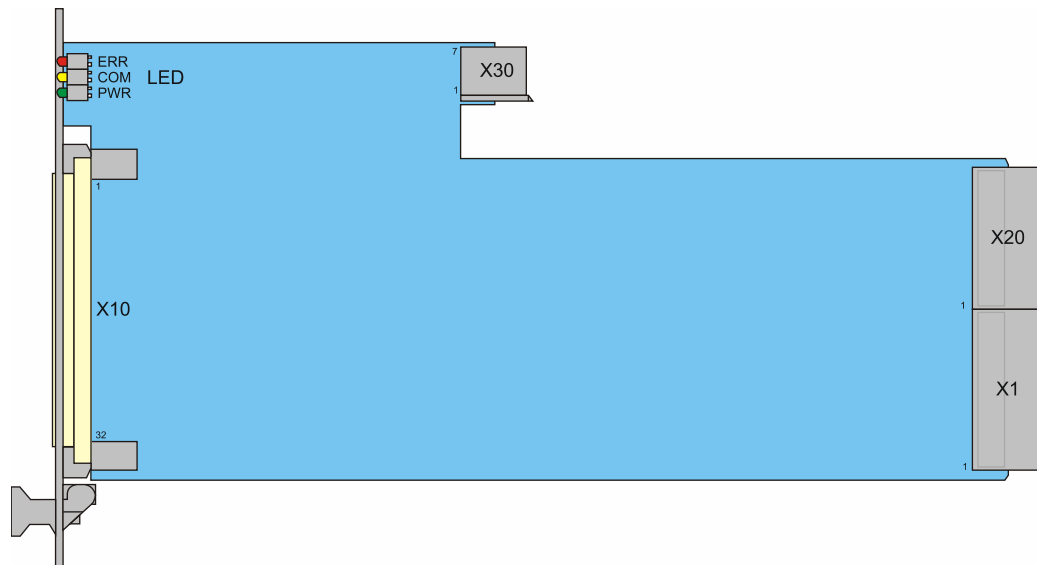

**Figure 4-1: Overview of the connectors and LEDs on the module R&S TS-PIO2**

LEDs = [Chapter 4.1.1, "Status LEDs"](#), on page 13

X1 = [Chapter 4.1.2, "Connectors X1 and X20"](#), on page 13

X10 = [Chapter 4.1.3, "Connector X10"](#), on page 14

X20 = [Chapter 4.1.2, "Connectors X1 and X20"](#), on page 13

X30 = [Chapter 4.1.4, "Connector X30"](#), on page 14

#### 4.1.1 Status LEDs

The LEDs on the front indicate the current status of the module.

- "PWR" (green LED)  
Indicates that all necessary supply voltages are present.
- "COM" (yellow LED)  
Indicates data exchange via the interface.
- "ERR" (red LED)  
Indicates an error condition if illuminated.

#### 4.1.2 Connectors X1 and X20

**Type:** Control bus

Interface to connect the module to the backplane of the base unit.

See [Chapter C.1.1, "Connector X1"](#), on page 49 and [Chapter C.1.2, "Connector X20"](#), on page 50 for a detailed description of the connectors.

### 4.1.3 Connector X10

Interface to connect test objects and UUTs to the module.

See [Chapter C.1.3, "Connector X10"](#), on page 51 for a detailed description of the connector.

### 4.1.4 Connector X30

**Type:** Analog bus

Interface to connect the module to the analog bus backplane in the housing of the base unit.

See [Chapter C.1.4, "Connector X30"](#), on page 53 for a detailed description of the connector.

## 4.2 R&S TS-PDC

The R&S TS-PDC is a rear panel I/O module that you must connect with the R&S TS-PIO2 in a PXI based base unit.



The module R&S TS-PDC exists in 3 different models:

- Grouted in a black housing - version up to 1.8 (1157.9804.02 obsolete)
- Encapsulated in metal housing with cooling fins - version 1.9 (1157.9804.02 obsolete)
- Without case - version from 2.0 (1157.9804.12 current version)

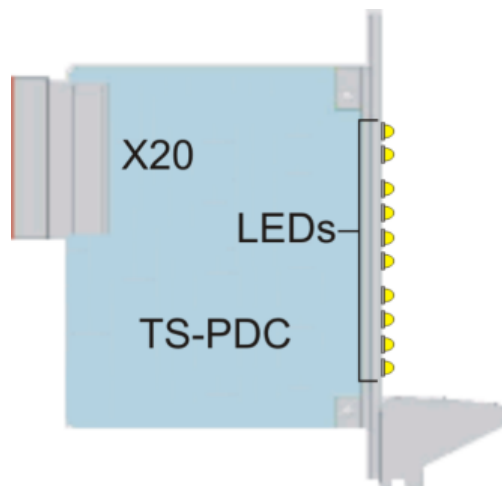

**Figure 4-2: Overview of the connector and LEDs on the R&S TS-PDC module**

LEDs = [Chapter 4.2.1, "Status LEDs"](#), on page 15

X20 = [Chapter 4.2.2, "Connector X20"](#), on page 16

## 4.2.1 Status LEDs

The meaning of the status LEDs depend on the module version.

### Module version < 2.0 (1157.9804.02)

Eight green LEDs indicate the status of the module. Each LED indicates the presence of an output voltage.

In fault free operation all 8 LEDs must light up simultaneously.

### Module version $\geq$ 2.0 (1157.9804.12)

Ten LEDs indicate the status of the module. The LEDs have the following meaning.

- "PWR" (green color)  
Indicates that the module is on and running.
- "ERR" (orange color)  
Indicates that the module has shut down because of an overload or a temperature that is too high.
- "<xx> V" (eight LEDs in green color)  
Indicate the presence of an output voltage.  
In fault free operation all 8 voltage LEDs must light up simultaneously.

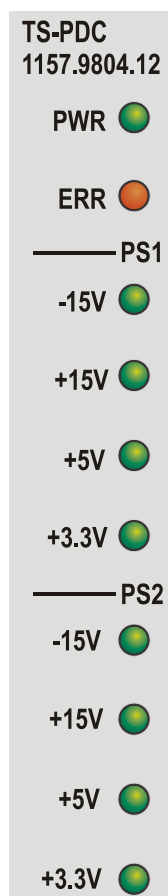

Figure 4-3: LEDs on the R&S TS-PDC module from Version 2.0

### 4.2.2 Connector X20

Interface to connect the R&S TS-PDC to the backplane of R&S TSVP base units.

See [Chapter C.2, "R&S TS-PDC"](#), on page 54 for a detailed description of the connector.



## 5 Installing the module

The R&S TS-PIO2 is a module installed on the front panel of R&S TSVP base units. It requires a R&S TS-PDC rear I/O supply module.

1. Install the R&S TS-PIO2 front module as described in the user manuals for the base units.
2. Install the R&S TS-PDC supply module in the matching rear I/O slot as described in the user manuals for the base unit.
3. **WARNING!** Risk of electric shock. The test environment, e.g the UUT or additional power supplies, can supply high voltages to the instruments. In this case, the voltage can also apply to the signal output connectors of the R&S TSVP, in particular the analog bus connector X2.

Therefore, do not connect or disconnect devices from the X2 connectors while connected to an external power supply or UUT.

Always connect both ends of the cable connecting the R&S CompactTSVP and R&S PowerTSVP. Thus, you avoid the risk of touching the X2 connector with a possibly hazardous voltage applied.

Take the system into operation as described in the user manuals for the base unit.

## 6 Function description

### 6.1 R&S TS-PIO2

#### 6.1.1 General

The Analog/Digital IO Module R&S TS-PIO2 makes 16 IO channels (CH1 to CH16) available. The channels are arranged in four groups from A to D. The last output channel of each group (CH4, CH8, CH12 and CH16) has special properties.

**Table 6-1: Channels and corresponding groups**

Channel	Group	Analog bus access	Note
CH1	A	ABa1, ABa2	
CH2	A	ABa1, ABa2	
CH3	A	ABa1, ABa2	
CH4	A	ABa1, ABa2	Extended channel
CH5	B	ABb1, ABb2	
CH6	B	ABb1, ABb2	
CH7	B	ABb1, ABb2	
CH8	B	ABb1, ABb2	Extended channel
CH9	C	ABc1, ABc2	
CH10	C	ABc1, ABc2	
CH11	C	ABc1, ABc2	
CH12	C	ABc1, ABc2	Extended channel
CH13	D	ABd1, ABd2	
CH14	D	ABd1, ABd2	
CH15	D	ABd1, ABd2	
CH16	D	ABd1, ABd2	Extended channel

The outputs of the various channels are capable of functioning in the following operating modes:

- Analog
- Digital Static
- Digital Dynamic
- Waveform
- Square Wave

The individual modes are described in greater detail in the following chapters.

Some of the settings for a channel can be made channel-specifically or group-specifically. The following illustration is a graphical representation showing the possible settings for channel outputs in group A. The output level depends on the contents of the level registers and the state of the pattern register. With square wave output, the corresponding switch is switched cyclically between H and L while a „1“ is entered in the pattern register for this channel.

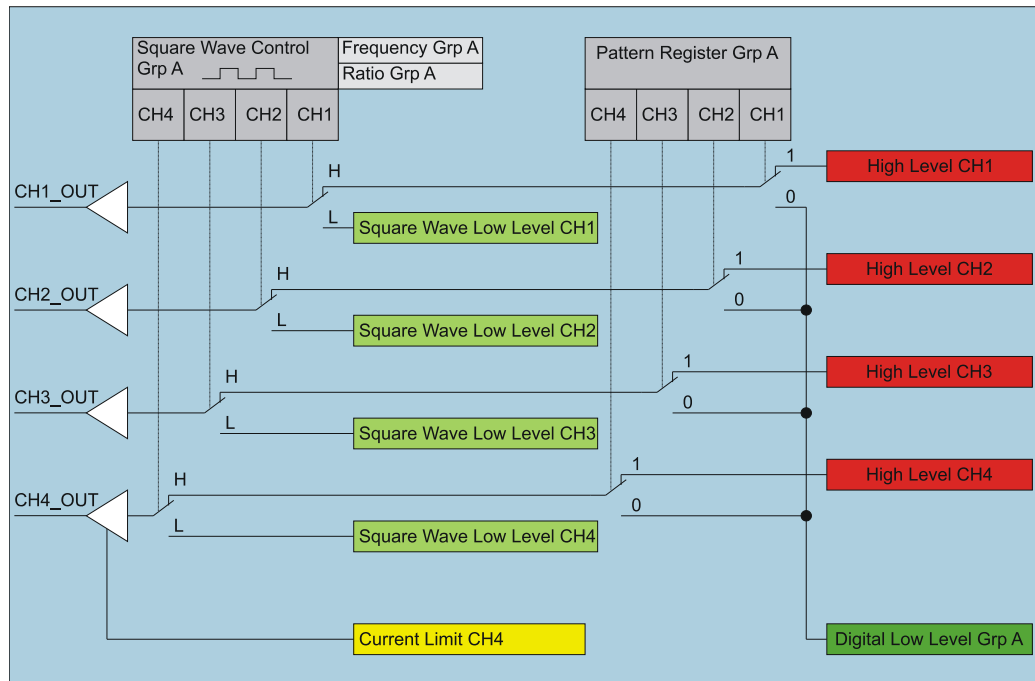

Figure 6-1: Channel- and group-specific parameters of the outputs (group A)

### 6.1.2 Application examples

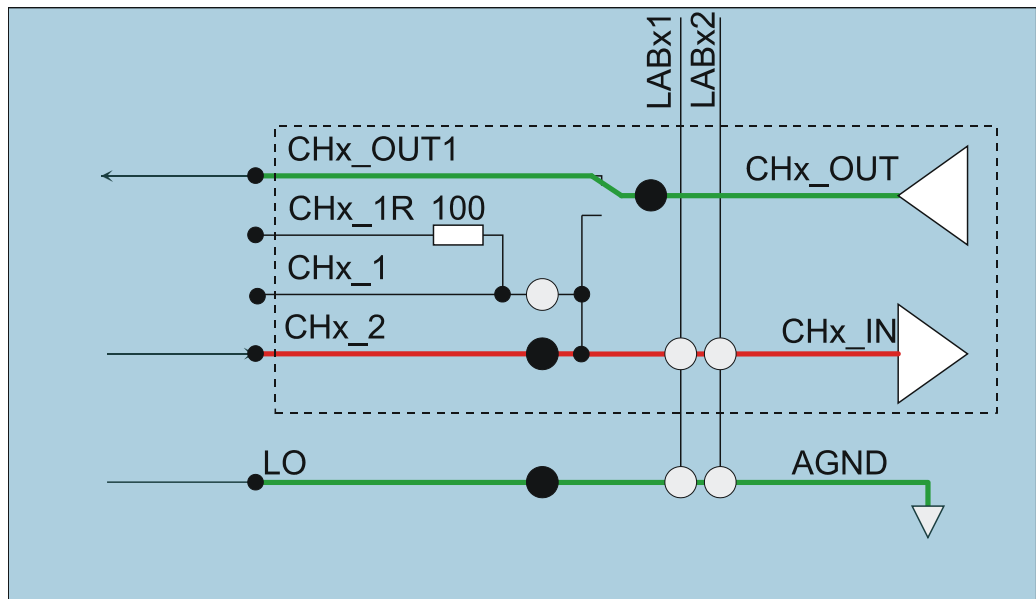

Figure 6-2: Independent use of input and output

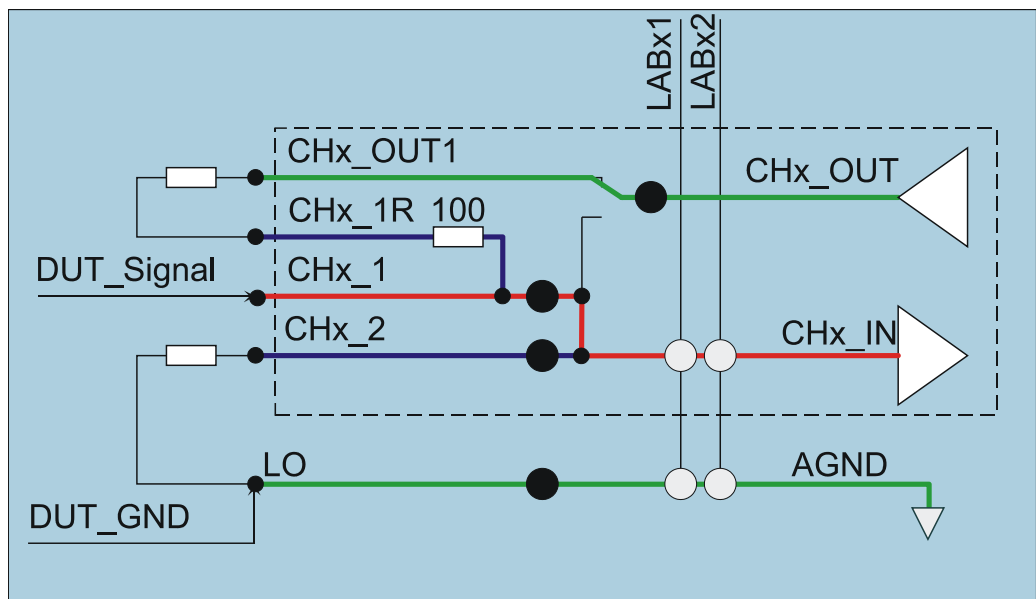

Figure 6-3: Switchable loads (pull-up and pull-down of digital inputs)

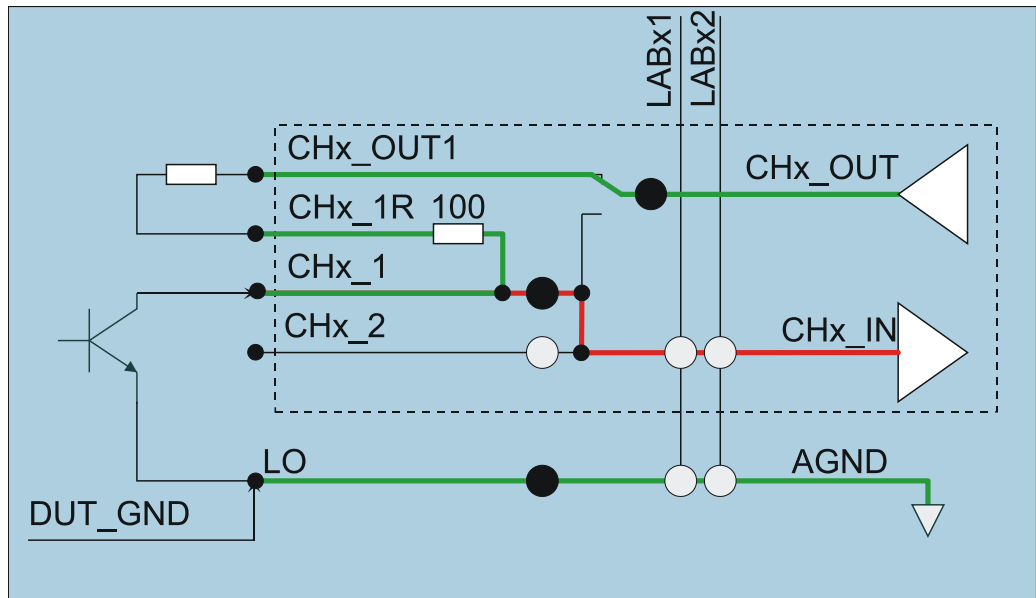

Figure 6-4: Test of „Low-Side“ outputs (OC, OD, optocoupler, switch, etc.)

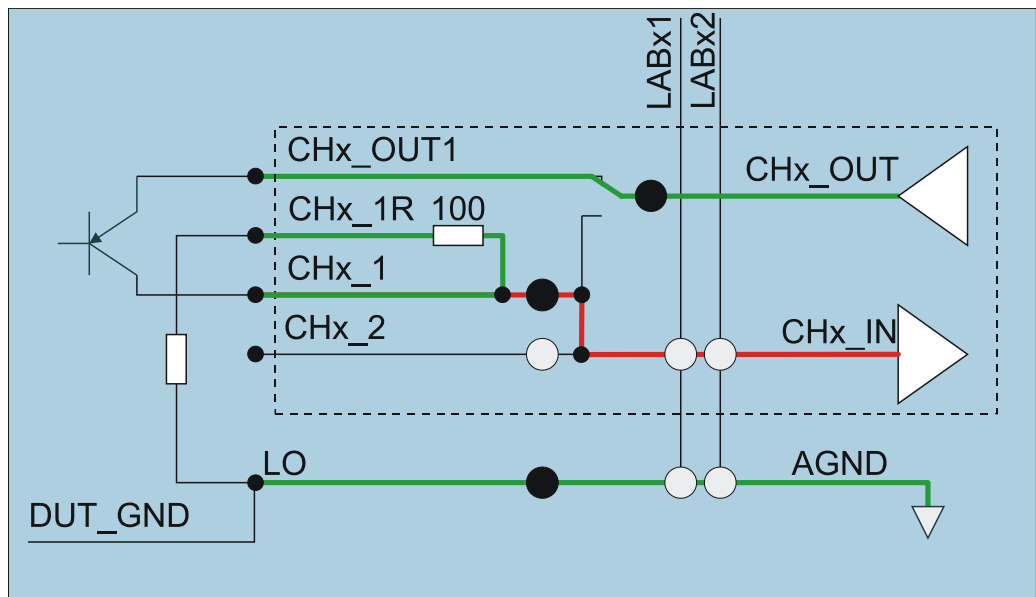

Figure 6-5: Test of „High-Side“ outputs (OC, OD, optocoupler, switch, etc.)

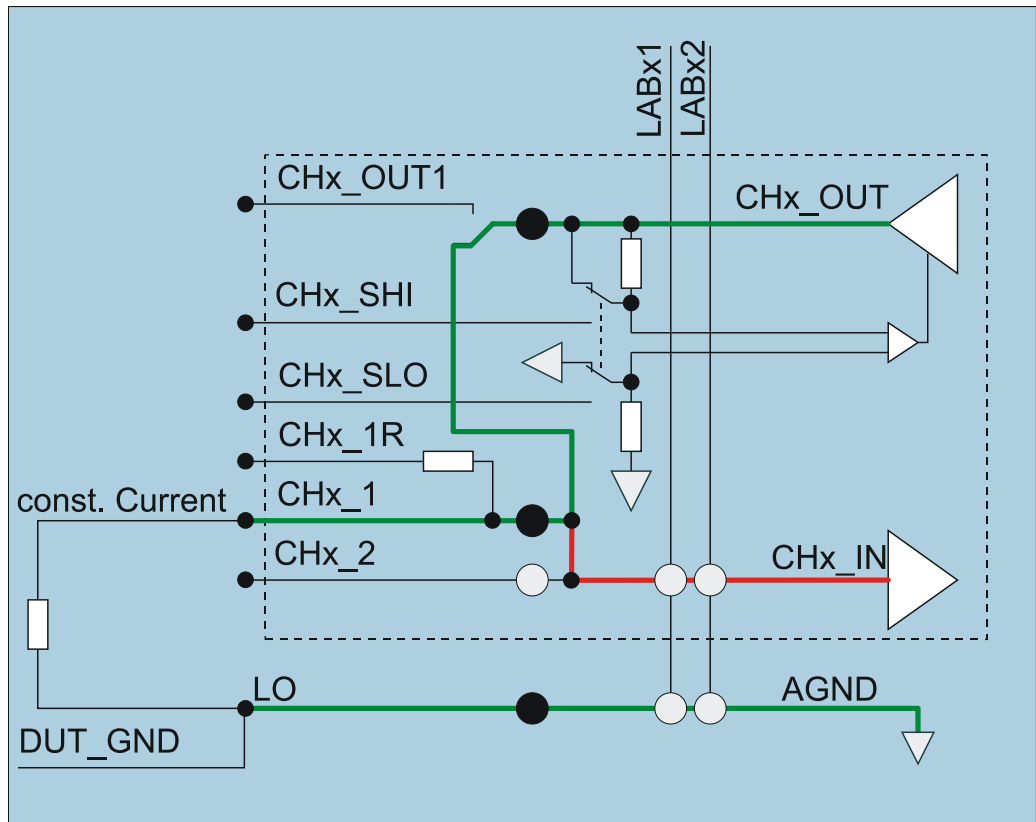

Figure 6-6: Extended channel for implementing current interfaces (0.5 mA ...100 mA, actuators)

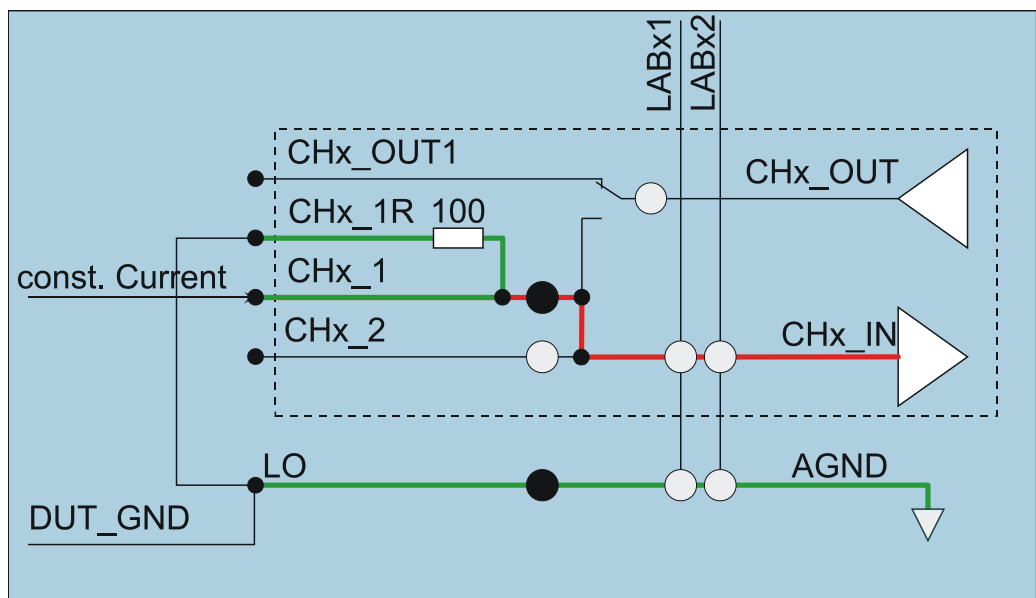

Figure 6-7: Evaluation of current interfaces (sensors)

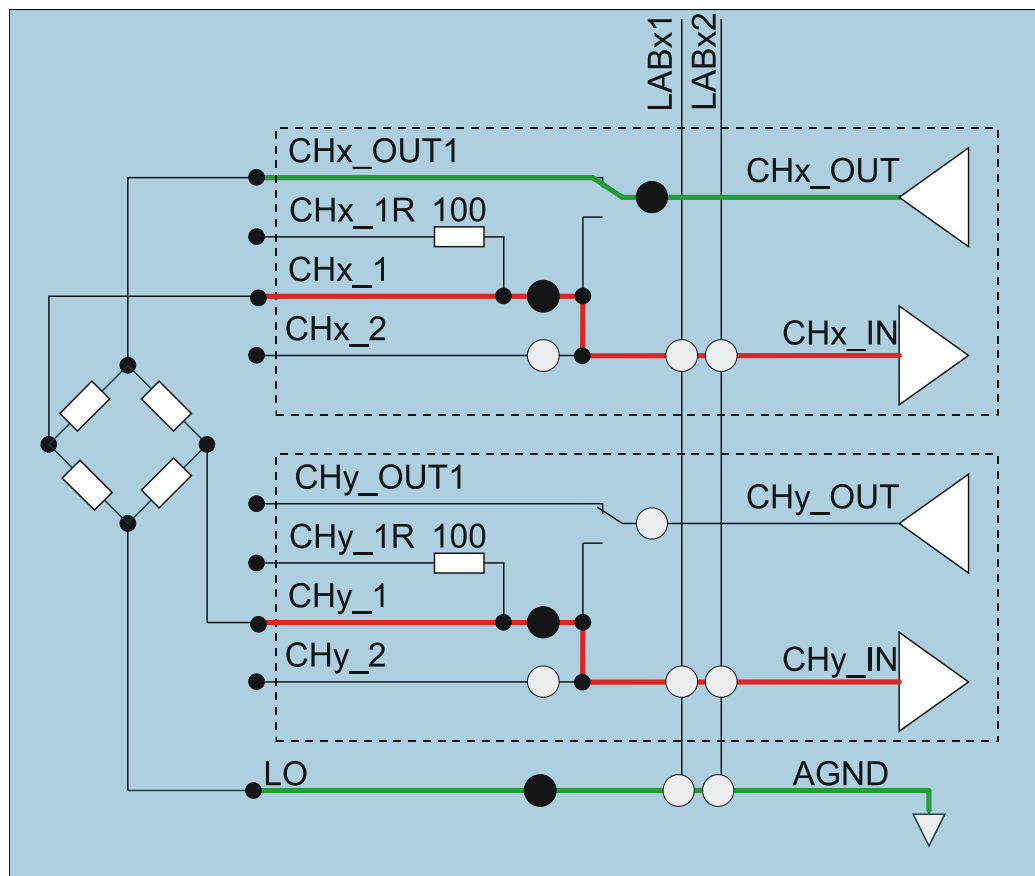

Figure 6-8: Differential measurement on bridge sensors

### 6.1.3 Signal wiring

All signal wiring of the R&S TS-PIO2 module is performed with the aid of relays. Since relays have an operate and release time as well as a bounce time, you should wait until the signals are stable in a test program after wiring connections.

1. **NOTICE!** Risk of damage to the relay contacts. Switch relays only with currents in the specified range.  
Using currents outside the specified range can damage or destroy the relay contacts.  
Use function `rspio2_WaitForDebounce` to wait until all switching processes are complete.  
When all switching processes are complete, the system returns control to the test program.
2. Use function `rspio2_IsDebounced` to confirm that all switching processes are complete.

Figure 6-9 shows a number of typical permissible voltage configurations between the analog buses and ground.

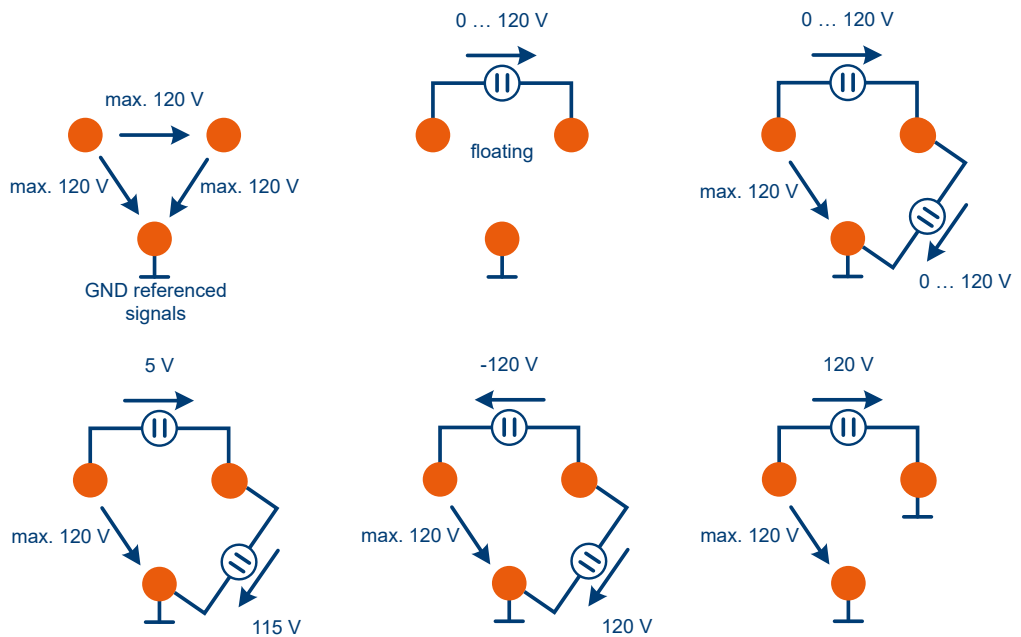

Figure 6-9: Permissible voltages on analog bus lines

### 6.1.3.1 Module ground wiring

The module ground (potential-free common reference point of IO channels, AGND) can be connected via relays with the front side connector (LO) and with each line of the analog bus (ABxy).

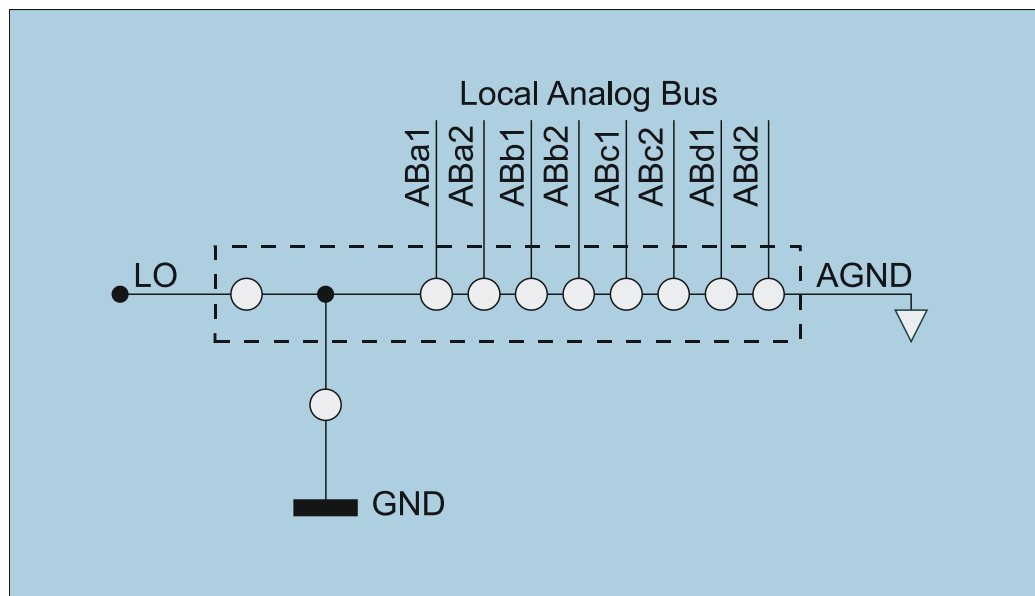

Figure 6-10: Relays for wiring the module ground



The following functions are available to operate these relays:

- `rspio2_Connect`
- `rspio2_Disconnect`
- `rspio2_DisconnectAll`

Function `rspio2_DisconnectAll` can be used to break all connections created with `rspio2_Connect` with a single function call.



`rspio2_DisconnectAll` has no effect on the configuration of outputs, coupling relays, or the ground relay.

The potential-free module ground can also be connected to ground with the aid of the ground relay (see Section 5.1.3.6)

### 6.1.3.2 Switching inputs

The inputs of each channel can be switched via a multiplexer to the front side connector (CHx\_1 or CHx\_2) or the TSVP analog bus (see Table 5-1 channels and corresponding groups).

The following functions are available to operate these relays:

- `rspio2_Connect`
- `rspio2_Disconnect`
- `rspio2_DisconnectAll`

Function `rspio2_DisconnectAll` can be used to break all connections created with `rspio2_Connect` with a single function call.



`rspio2_DisconnectAll` has no effect on the configuration of outputs, coupling relays, or the ground relay.

### 6.1.3.3 Switching outputs

Function `rspio2_ConfigureOutputMux` configures the switching state of the outputs of a channel. The following settings are possible:

- Output disconnected
- Output connected with front side connector (CHx\_OUT1)
- Output connected with corresponding input (CHx\_IN)



Please note that function `rspio2_DisconnectAll` does not affect this setting!

#### 6.1.3.4 Coupling relay

The coupling relays connect the local analog bus (LAB) on the module with the analog bus in the R&S CompactTSVP or R&S PowerTSVP. The function `rspio2_ConfigureCoupling` defines the status of the coupling relays.



Please note that function `rspio2_DisconnectAll` does not open these relays!

#### 6.1.3.5 Ground relays

The R&S TS-PIO2 module has a ground relay that can be used to connect the potential-free module ground (AGND) with ground (GND).

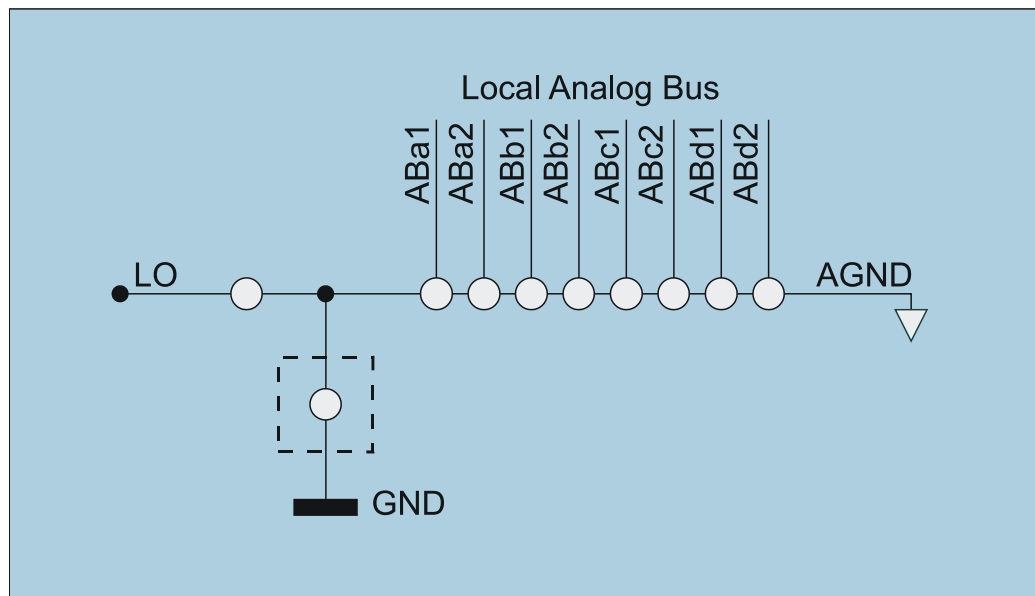

Figure 6-11: Ground relay

The module is operated ground-free in its basic state. This state can be changed using the function `rspio2_ConfigureGround`.



Please note that function `rspio2_DisconnectAll` does not open the ground relays!



For technical reasons, a non-switched R&S TS-PIO2 module (no connection of signals to the front side connector or analog bus) is automatically grounded through the ground relay. This relay is automatically opened again before new switching is performed. This applies if the R&S TS-PIO2 module is configured groundfree.

### 6.1.4 Using sense lines

To compensate for voltage drops in the power supply to the external load, the extended channels (CH4, CH8, CH12 and CH16) of R&S TS-PIO2 can be set to external sensing. Two additional lines directly to the test object are required for this purpose. The measured difference in voltage on these lines is automatically controlled to the target voltage by R&S TS-PIO2.

The sense lines on the front side connector (CHx\_SHI und CHx\_SLO) are switched using function `rspio2_ConfigureRemoteSensing`.

### 6.1.5 Adjusting current limiting

The extended channels (CH4, CH8, CH12 and CH16) of the R&S TS-PIO2 make it possible to adjust current limiting. The set value is independent of the mode of a channel and is always applied to it. Function `rspio2_ConfigureChannelCurrentLimit` facilitates this setting.

### 6.1.6 Output of static voltages

In the basic state of the module, all outputs are in the „Analog“ operating mode. If necessary, this mode can also be selected with function `rspio2_ConfigureChannelMode`.

The voltage can be adjusted channel-specifically with function `rspio2_ConfigureChannelLevels` Parameter „Output High Level“ determines the output voltage.

### 6.1.7 Output of static digital bit patterns

A channel can be switched to „Digital Static“ mode using function `rspio2_ConfigureChannelMode`. Any number of channels can be operated in this mode. Depending on which bit pattern is programmed, either the channel-specific voltage „Output High Level“ or the voltage assigned to a group „Output Digital Low Level“ is generated.

**Table 6-2: Output voltages in mode „digital static“ and „digital dynamic“**

Pattern value	Generated voltage	Setting function of the voltage value
0	Output Digital Low Level	<code>rspio2_ConfigureGroup</code>
1	Output High Level	<code>rspio2_ConfigureChannelLevels</code>

The pattern value for channels in „Digital Static“ mode can be set with function `rspio2_SetDigitalOutputState` One parameter of this function serves as a mask so that the individual channels can be operated.



When switching from the „Analog“, „Waveform“ or „Square Wave“ mode to „Digital Static“ mode, level „Output High Level“ is generated (pattern value „1“).

### 6.1.8 Output of dynamic digital bit patterns

In the „Digital Dynamic“ operating mode, the output voltage of the relevant channels is determined by a digital bit pattern which is updated cyclically after sequence control begins (see Section 5.1.13).

This mode can be selected for a channel using function `rspio2_ConfigureChannelMode`. Any number of channels can be switched to this mode.

The high and low level for the relevant channels can be set like in „Digital Static“ mode (see Section 5.1.7).

Before sequence control begins, the bit pattern must be loaded into the R&S TS-PIO2 module. Function `rspio2_SetDigitalDynamicMemory` is used for this purpose. A maximum of 5000 values can be written to memory. If fewer values have been stored in memory than sequence control needs to generate, the last value is repeated.



When switching from „Analog“, „Waveform“ or „Square Wave“ mode to „Digital Dynamic“ mode, level „Output High Level“ is generated (pattern value „1“). If level „Output Digital Low Level“ should be present before dynamic bit pattern output begins, pattern value „0“ must first be set in the „Digital Static“ mode.

### 6.1.9 Output of arbitrary waveforms

One of the 16 channels can be switched to the „Waveform“ mode using function `rspio2_ConfigureChannelMode`. To do this, the pattern register value is set to „1“ for that channel. After sequence control has started (see Section 5.1.13), the output voltage of this channel is determined by the values in arbitrary waveform memory. The values are transferred to the „High Level“ register.

Function `rspio2_SetAnalogWaveformMemory` is used to transfer the values to the R&S TS-PIO2 module. As in the case of digital bit patterns, a maximum of 5000 values can be written to memory. If fewer values have been stored in memory than sequence control needs to generate, the last value is repeated.



Operating modes „Waveform“ and „Square Wave“ cannot be selected simultaneously within one group.

### 6.1.10 Output of square wave signals

For a channel to generate a square wave signal, the „Square Wave“ operating mode must first be activated with function `rspio2_ConfigureChannelMode`. Multiple channels can be operated simultaneously in this mode.

When square wave signals are generated, both the high and low level can be adjusted channel-specifically using function `rspio2_ConfigureChannelLevels`. When square wave generating stops, the „Output High Level“ is always generated. The frequency and duty cycle are always determined for the corresponding group. This is done with function `rspio2_ConfigureSquareWave`. The frequency and duty cycle can also be changed while the signal is being generated.

When adjusting the square wave signal, the rise and fall times of channels specified on the data sheet must be taken into consideration. The extended channels have longer times.

Output of square wave signals is finally started for a group with function `rspio2_SquareWaveEnabled`. The same function is used to stop generating square wave signals. The parameters of the function make it possible to start output for several groups synchronously.

Generation of square wave signals is independent of sequence control for recording of measurement values and of the output of digital bit patterns and arbitrary waveforms.



If the output of a square wave signal is enabled for a group, the following settings cannot be modified for any channels in that group:

- Output High Level
- Output Square Wave Low Level
- Output Current Limit
- Output Digital Low Level
- Input Digital High Threshold
- Input Digital Low Threshold

### 6.1.11 Recording digital measurement values

Each input is directed to two comparators with adjustable trip levels. This makes it possible to implement a hysteresis for evaluating signals. The limits can be set using function `rspio2_ConfigureGroup`. This makes it possible to set individual limits for each group of channels.

The result of the signal evaluation of a channel is „1“ if the input level is greater than value „Input Digital High Threshold“. The result of the signal evaluation of a channel is „0“ if the input level is less than value „Input Digital Low Threshold“.

If the input level is between limit values, the last state is always retained.

Digital measurement values are recorded in parallel to the voltage measurement. The process is started with sequence control (see Section 5.1.13). The results can be retrieved with function `rspio2_FetchDigital`.

### 6.1.12 Voltage measurements

Two methods are available for voltage measurement on inputs:

**Table 6-3: Methods for voltage measurement**

Method	Note
Single Ended	The level is measured between one input (CHx_IN) and module ground (AGND or LO on the front side connector)
Differential	The level between two inputs is determined by taking the difference. The following combinations of inputs are possible: CH1 - CH9 CH2 - CH10 CH3 - CH11 CH4 - CH12 CH5 - CH13 CH6 - CH14 CH7 - CH15 CH8 - CH16

The following measurement ranges can be set:

- 7V
- 14V
- 28V

Voltage measurement can be configured with function `rspio2_ConfigureAnalogMeasurement`.

Recording of measurement values is monitored by sequence control (see Section 5.1.13). The setting of the the time interval also determines the conversion time of the ADC and thus the input bandwidth and accuracy that can be achieved. Because of this, parameter „Sample Interval“ of function `rspio2_ConfigureSampling` is meaningful even if only one measurement value („Sample Count“ = 1) will be recorded!

**Table 6-4: Effect of „sample interval“ on bandwidth and accuracy**

Interval	Input Bandwidth	Accuracy
200 $\mu$ s $\leq$ Sample Interval < 1 ms	High	Lower
1 ms $\leq$ Sample Interval < 10.0 ms	Medium	Higher
10.0 ms $\leq$ Sample Interval $\leq$ 1 s	Low	Best

Recording of measurement values is started by sequence control (see Section 5.1.13). The results can be queried with function `rspio2_FetchAnalog`. If you are only interested in the average value of all the samples recorded, it can be retrieved with `rspio2_FetchAverage`.

### 6.1.13 Triggering and sequence control

Measurement values are recorded and output of digital bit patterns is monitored by a central control system. Function `rspio2_ConfigureSampling` can be used to define the number of „Samples“ that will be recorded or generated. The time interval between the „Samples“ can be adjusted with this function.

The following actions are performed by sequence control in each time slot:

- A digital bit pattern is generated if at least one output is in „Digital Dynamic“ mode
- An analog waveform value is generated if a channel is running in „Waveform“ mode
- A pulse is generated on the configured trigger lines
- A digital bit pattern is read
- A measurement value is read

Various trigger sources are available to start sequence control:

**Table 6-5: Trigger sources**

Trigger source	Note
Immediate	Sequence control starts immediately when function <code>rspio2_Initiate</code> is called
External	Ground referenced TTL input XT11 on the front side connector; positive signal edge triggers sequence control
Software	Sequence control is started with function <code>rspio2_SendSoftwareTrigger</code>
PXI0 ... PXI7	Positive signal edges on the PXI trigger lines start sequence control

Function `rspio2_ConfigureTriggerSource` determines the trigger source. Function `rspio2_Initiate` is used to enable the previously configured trigger source. Sequence control is in the „Initiated“ state. As soon as the trigger event has occurred, the control system switches to the „Sampling“ state. After the set number of „Samples“ has been read in or generated, sequence control returns to its basic state. Then the data that was read in can be retrieved with the corresponding functions (`rspio2_FetchAnalog`, `rspio2_FetchAverage`, `rspio2_FetchDigital`). These functions have a „Timeout“ parameter. If sequence control has not expired during the time that was transferred, an error is returned. Otherwise the results are returned.



If sequence control is in the „Initiated“ or „Sampling“ mode, some functions cannot be performed. In that case, those functions return an error message. If necessary, sequence control can be switched to its basic state with the `rspio2_Abort` function.

### 6.1.14 Generating trigger signals

The R&S TS-PIO2 module is capable of generating trigger signals on the following lines:

**Table 6-6: Trigger outputs**

Name	Note
XTO1	Ground referenced TTL output XTO1 on the front side connector
PXI0 ... PXI7	PXI trigger lines on the backplane

For a change to occur on the trigger lines, an event must be assigned to the selected line that generates the trigger pulse. The following settings are possible:

**Table 6-7: Events for generating a trigger pulse**

Name	Note
General Purpose Trigger	Function <code>rspio2_InitiateTrigger</code> generates a pulse approximately 1 $\mu$ s in length on the configured trigger lines.
Sequence Start	A pulse approximately 1 $\mu$ s in length is generated on the configured trigger lines when sequence control starts.
Sample Clock	A pulse approximately 1 $\mu$ s in length is generated in each time slot of sequence control on the configured trigger lines.

The polarity of the trigger signal can also be determined for the individual outputs. The output drivers for the PXI trigger lines can also be switched off.

All settings are made with the aid of function `rspio2_ConfigureTriggerOutput`.

### 6.1.15 Autocorrection

To make it possible to achieve higher levels of accuracy, a process must be started under some circumstances to determine new correction values automatically. This process is performed with the aid of function `rspio2_PerformAutoCorrection`. It takes about one minute to determine the correction values. The function is not finished until the process is complete. After the correction procedure, the R&S TS-PIO2 module is in its reset state.

If the requirements for accuracy are not as great, function `rspio2_PerformFastAutoCorrection` can be performed. This process takes only about 2 seconds to complete.

The autocorrection must be performed after 24 hours of operating time, or if the temperature on the R&S TS-PIO2 module changes by 5 degrees Celsius. The driver monitors these parameters. Function `rspio2_QueryDeviceState` can be used to query whether the correction procedure must be started.



Function `rspio2_QueryDeviceState` always requests an autocorrection if the R&S TS-PIO2 module has just been turned on or reset by a hardware reset.

### 6.1.16 Excess temperature protection

There are four temperature sensors on the R&S TS-PIO2 module. If one of these sensors reports an inadmissible temperature, the module switches off automatically. The functions for switching signals and activating outputs return an error message in this state. Complete operation of R&S TS-PIO2 is not possible until the temperature is in the permissible range and use of the protective measure has been acknowledged by calling function `rspio2_reset`. Function `rspio2_QueryDeviceState` can be used to query the state of temperature monitoring.



## 6.2 R&S TS-PDC

The Rear I/O Module R&S TS-PDC is configured as a primary reference DC/DC converter. The input voltage (5 VDC) is transferred to two secondary potentials and rectified to the nominal voltage by line controllers. The status of the output voltage is displayed in each case by an LED.

The following DC voltages are generated:

- +15 V DC, 0,5 A (2x)
- -15 V DC, 0,5 A (2x)
- +5 V DC, 0,5 A (2x)
- +3,3 V DC, 0,25 A (2x)

## 7 Software

### 7.1 Driver software

A LabWindows IVI driver that supports the class IVI SWTCH is available for the functions of the Analog/Digital IO Module R&S TS-PIO2. The driver is a component of the ROHDE & SCHWARZ GTSL software program. All functions of the driver are documented extensively in online Help and in the LabWindows/CVI Function Panels.

During driver installation, the following software modules are installed:

**Table 7-1: Driver installation R&S TS-PIO2**

Module	Path	Comment
rspio2.dll	<GTSL directory>\Bin	Driver
rspio2.chm	<GTSL directory>\Bin	Help files
rspio2.fp	<GTSL directory>\Bin	LabWindows CVI Function Panel file, function panels for CVI development interface
rspio2.sub	<GTSL directory>\Bin	LabWindows CVI attribute file. This file is required by some „function panels“.
rspio2.lib	<GTSL directory>\Bin	Import Library
rspio2.h	<GTSL directory>\Include	Header file for the driver



To use the driver, the IVI and VISA libraries from National Instruments are necessary.

### 7.2 Soft panel

A Soft Panel is available for the Analog/Digital IO Module R&S TSPIO2 ([Figure 7-1](#)). The Soft Panel requires the IVI driver. The Soft Panel facilitates interactive operation of the module. Output of measurement values is in graphical format.

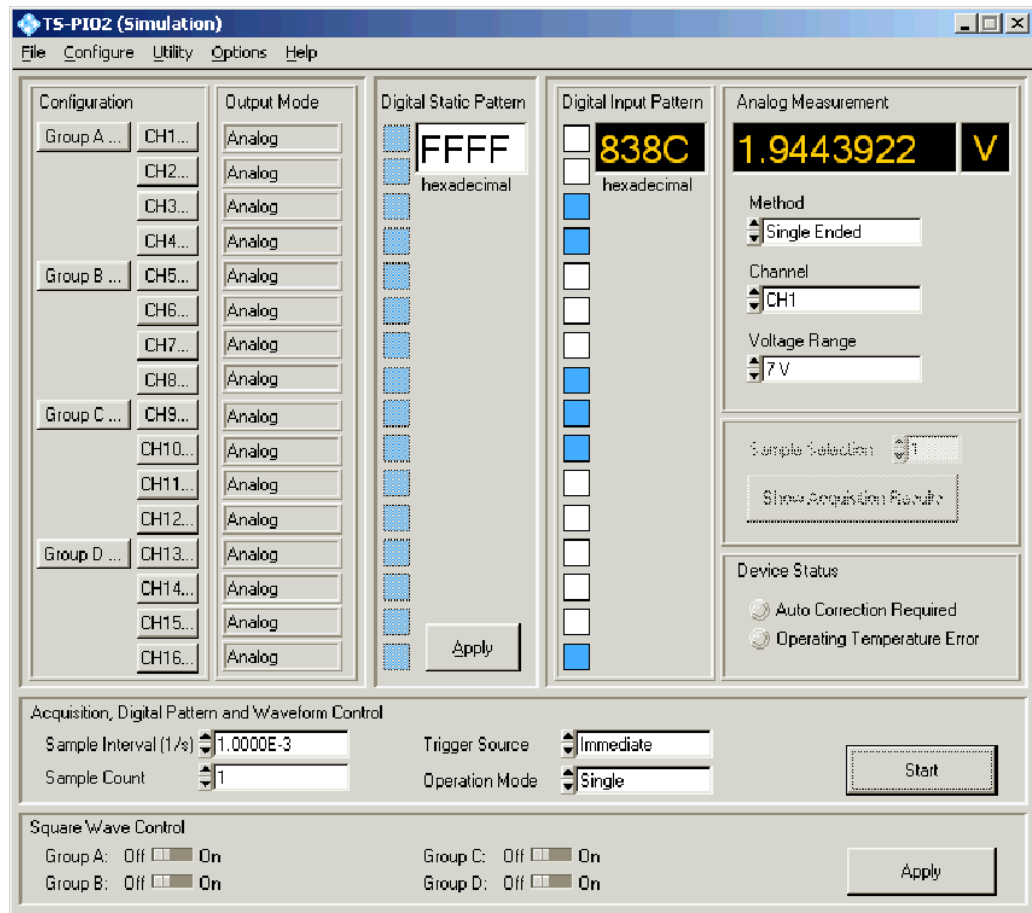

Figure 7-1: Soft Panel R&S TS-PIO2



The operation of the Soft Panel is described in the *R&S GTSL Software Description*.

The signal paths connections of the R&S TS-PIO2 can also be determined by the Soft Panel (Figure 7-3).

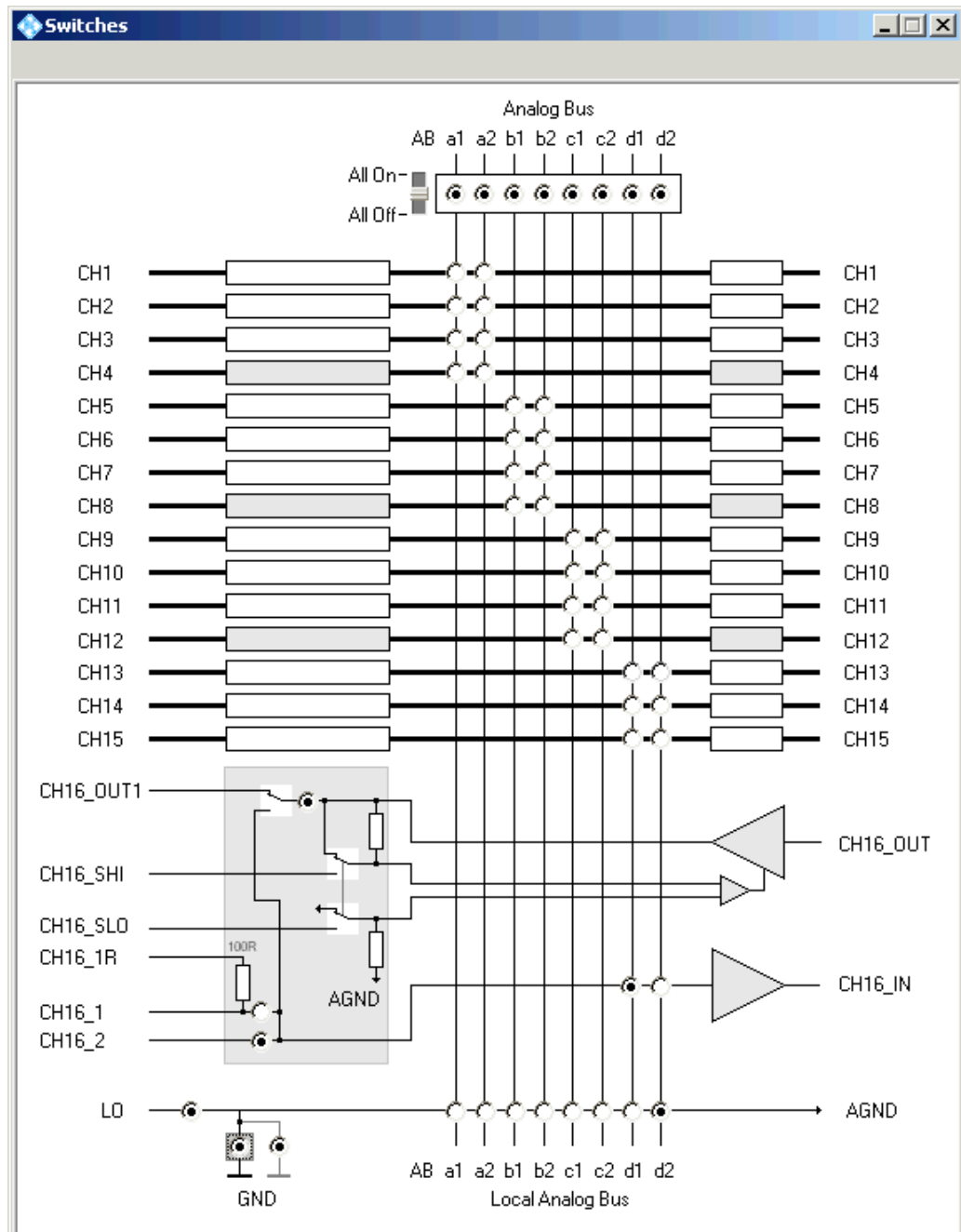

Figure 7-2: Soft Panel R&S TS-PIO2 connections

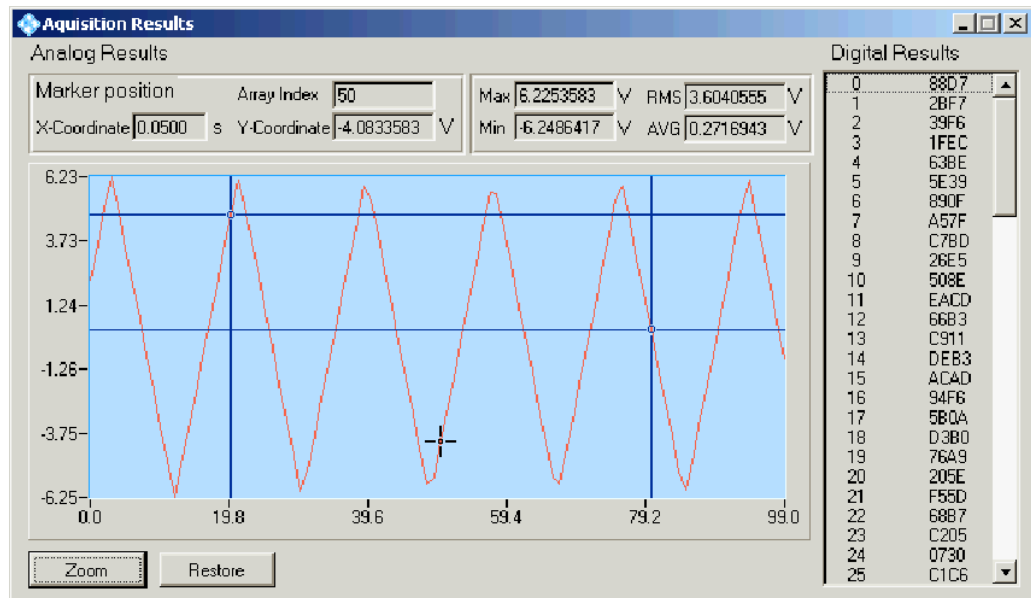

Figure 7-3: Soft Panel R&S TS-PIO2 measurement results

## 7.3 Sample program R&S TS-PIO2

```

/*
   This example connects all channels to the front connector, configures
   the channels and starts the output/acquisition sequence.

   Error handling is not considered in this sample in order to
   keep it easy to read. The return status should be checked for
   VI_SUCCESS after each driver call.
*/

#include <ansi_c.h>
#include "rspio2.h"

#define SAMPLE_COUNT      16
#define SAMPLE_INTERVAL   1E-3

static ViChar * s_pGrpName[] =
{
    "GRP_A",
    "GRP_B",
    "GRP_C",
    "GRP_D"
};

```

```

static ViUInt16 s_digiStim[SAMPLE_COUNT];
static ViUInt16 s_digiResp[SAMPLE_COUNT];
static ViReal64 s_waveform[SAMPLE_COUNT];
static ViReal64 s_measResult[SAMPLE_COUNT];

int main (int argc, char *argv[])
{
    ViSession vi;
    ViStatus  status;
    ViReal64  result;
    ViChar    chName[5], ch1[8], ch2[8];
    ViInt32   idx;

    /*
     * open a session to the device driver. The resource descriptor
     * depends on the slot number of the module and must be adapted
     * to the target system.
     */
    status = rspio2_InitWithOptions ("CAN0::0::2::7::INSTR",
                                     VI_TRUE,
                                     VI_TRUE,
                                     "Simulate=0,RangeCheck=1",
                                     &vi);

    /* configure sample count and interval */
    status = rspio2_ConfigureSampling (vi, SAMPLE_COUNT, SAMPLE_INTERVAL);

    /* fill stimulus buffer */
    for (idx = 0; idx < SAMPLE_COUNT; idx++)
    {
        s_digiStim[idx] = idx;           /* counter */
        s_waveform[idx] = idx * (10.0 / SAMPLE_COUNT); /* ramp */
    }

    /* upload samples */
    status = rspio2_SetDigitalDynamicMemory (vi, SAMPLE_COUNT, s_digiStim);
    status = rspio2_SetAnalogWaveformMemory (vi, SAMPLE_COUNT, s_waveform);

    /* configure voltage measurement at CH16 */
    status = rspio2_ConfigureAnalogMeasurement (vi, "CH16", 14.0);

    /* configure square wave generation on CH9 and CH10 */
    status = rspio2_ConfigureSquareWave (vi, "GRP_C", 2000, 50);

    /* generate trigger puls at XT01 when output/acquisition sequence starts */
    status = rspio2_ConfigureTriggerOutput (vi, RSPIO2_TRIG_MASK_XT01,

```

## Sample program R&amp;S TS-PIO2

```
RSPIO2_VAL_TRIG_SEQ_START, 0,
RSPIO2_TRIG_MASK_XTO1);

/* configure module earth tied (connect AGND to GND) */
status = rspio2_ConfigureGround (vi, VI_TRUE);

/* connect AGND to front connector */
status = rspio2_Connect (vi, "AGND", "LO");

/* connect all output channel to front connector */
for (idx = 1; idx <= 16; idx++)
{
    sprintf(chName, "CH%d", idx);
    status = rspio2_ConfigureOutputMux (vi, chName,
                                        RSPIO2_VAL_OUTMUX_MODE_OUT1);
}

/* connect all input channel to front connector */
for (idx = 1; idx <= 16; idx++)
{
    sprintf(ch1, "CH%d_IN", idx);
    sprintf(ch2, "CH%d_1", idx);
    status = rspio2_Connect (vi, ch1, ch2);
}

/* wait until relays have settled; timeout 500 ms */
status = rspio2_WaitForDebounce (vi, 500.0);

/* configure channel 1 to 8 to mode digital dynamic */
for (idx = 1; idx <= 8; idx++)
{
    sprintf(chName, "CH%d", idx);
    status = rspio2_ConfigureChannelMode (vi, chName,
                                        RSPIO2_VAL_CH_MODE_DIGITAL_DYNAMIC);
}

/* configure channel 9 to 10 to mode square wave */
for (idx = 9; idx <= 10; idx++)
{
    sprintf(chName, "CH%d", idx);
    status = rspio2_ConfigureChannelMode (vi, chName,
                                        RSPIO2_VAL_CH_MODE_SQUAREWAVE);
}

/* configure channel 11 to 12 to mode digital static */
for (idx = 11; idx <= 12; idx++)
{
    sprintf(chName, "CH%d", idx);
    status = rspio2_ConfigureChannelMode (vi, chName,
                                        RSPIO2_VAL_CH_MODE_DIGITAL_STATIC);
}
```

```

}

/* configure channel 16 to mode waveform */
status = rspio2_ConfigureChannelMode (vi, "CH16",
                                     RSPIO2_VAL_CH_MODE_WAVEFORM);

/* configure current limit for the extended channels */
status = rspio2_ConfigureChannelCurrentLimit (vi, "CH4", 10.0e-3);
status = rspio2_ConfigureChannelCurrentLimit (vi, "CH8", 10.0e-3);
status = rspio2_ConfigureChannelCurrentLimit (vi, "CH12", 10.0e-3);
status = rspio2_ConfigureChannelCurrentLimit (vi, "CH16", 10.0e-3);

/* configure output high level to 3.3 V and square wave low level to 0 V */
for (idx = 1; idx <= 12; idx++)
{
    sprintf(chName, "CH%d", idx);
    status = rspio2_ConfigureChannelLevels (vi, chName, 3.3, 0.0);
}

/* configure output level for the analog channels */
status = rspio2_ConfigureChannelLevels (vi, "CH13", 3.3, 0.0);
status = rspio2_ConfigureChannelLevels (vi, "CH14", 5.0, 0.0);
status = rspio2_ConfigureChannelLevels (vi, "CH15", 12.0, 0.0);

/*
    configure group A, B, C for digital IO:

    output digital low level      0.0 V
    input digital high threshold 2.0 V
    input digital low threshold  0.8 V
*/
for (idx = 0; idx <= 2; idx++)
{
    rspio2_ConfigureGroup (vi, s_pGrpName[idx], 0.0, 2.0, 0.8);
}

/* set pattern for the digital static channel CH11 and CH12 */
status = rspio2_SetDigitalOutputState (vi, 0x0C00, 0x0800);

/* enable square wave */
status = rspio2_SquareWaveEnabled (vi, 0x4, 0x4);

/* start output/acquisition sequence with immediate trigger */
status = rspio2_Initiate (vi);

/* fetch the measurement results */
{
    ViInt32 actualPoints;

```



```
ViInt32 maxTime = SAMPLE_COUNT * SAMPLE_INTERVAL * 1000;

status = rspio2_FetchDigital (vi, maxTime, SAMPLE_COUNT,
                             s_digiResp, & actualPoints);
status = rspio2_FetchAnalog (vi, maxTime, SAMPLE_COUNT,
                             s_measResult, & actualPoints);
}

/* disable square wave generation */
status = rspio2_SquareWaveEnabled (vi, 0x4, 0x0);
/* disable all outputs */
for (idx = 1; idx <= 16; idx++)
{
    sprintf(chName, "CH%d", idx);

    /* set output high level to 0 V */
    status = rspio2_ConfigureChannelLevels (vi, chName, 0.0, 0.0);

    /* select output high level */
    status = rspio2_ConfigureChannelMode (vi, chName,
                                          RSPIO2_VAL_CH_MODE_ANALOG);

    /* disconnect output channel */
    status = rspio2_ConfigureOutputMux (vi, chName,
                                        RSPIO2_VAL_OUTMUX_MODE_OPEN);
}

/* disconnect the rest */
status = rspio2_DisconnectAll (vi);

/* configure module earth free again */
status = rspio2_ConfigureGround (vi, VI_FALSE);

/* reset module, close the driver session */
status = rspio2_close (vi);

return 0;
}
```

## 8 Maintenance, storage and disposal

### 8.1 Storage

Protect the product against dust. Ensure that the environmental conditions, e.g. temperature range and climatic load, meet the values specified in the data sheet.

### 8.2 Disposal

Rohde & Schwarz is committed to making careful, ecologically sound use of natural resources and minimizing the environmental footprint of our products. Help us by disposing of waste in a way that causes minimum environmental impact.

#### Disposing electrical and electronic equipment

A product that is labeled as follows cannot be disposed of in normal household waste after it has come to the end of its service life. Even disposal via the municipal collection points for waste electrical and electronic equipment is not permitted.



*Figure 8-1: Labeling in line with EU directive WEEE*

Rohde & Schwarz has developed a disposal concept for the eco-friendly disposal or recycling of waste material. As a manufacturer, Rohde & Schwarz completely fulfills its obligation to take back and dispose of electrical and electronic waste. Contact your local service representative to dispose of the product.

## 9 Troubleshooting

If the system is not running properly, try to find the problem with the following tests. If the tests do not help to locate the problem, contact your Rohde & Schwarz service representative.

- [LED test](#)..... 43
- [Power-on test](#).....43
- [R&S TSVP self-test](#).....44
- [Contacting customer support](#)..... 44

### 9.1 LED test

The module has three LEDs on its front panel that indicate its status.

After turning on the system, all LEDs light up for a short time to indicate that the power supply is present and that all LEDs are working.

- A single LED does not light up in that time frame:  
Indicates a faulty LED or faulty LED control.
- All LEDs do not light up during that time frame:  
Indicates that the power supply for the module is faulty.  
Check the status LEDs of the main power supply module in slot A3 and A4.

For rear modules, you have to check the LEDs separately, see "[Power-on test for modules with a rear I/O supply module](#)" on page 44.

### 9.2 Power-on test

The power-on test runs at the same time as the LED test. The following statements can be made regarding the different display states of the LEDs.

- "PWR LED" (green LED) = on  
Indicates that all power supply voltages are present.
- "PWR LED" (green LED) = off  
Indicates that at least one power supply voltage is missing.
- "ERR LED" (red LED) = off  
If the green LED is illuminated at the same time, indicates that the system is working without any errors.
- "ERR LED" (red LED) = on (or blinking)  
Indicates a hardware problem.

### Power-on test for modules with a rear I/O supply module

If the green LED indicates a problem with the supply voltage, check the LEDs of the corresponding rear I/O supply module separately. If the LEDs on the rear I/O module also indicate a supply voltage failure, replace the rear I/O module.

## 9.3 R&S TSVP self-test

The R&S TSVP self-test is an extensive test procedure for the whole system or individual components. After the test is done, you receive a test report for all components that have been tested.

The self-test uses the R&S TS-PSAM module as a measurement unit. The functionality of the modules in the system is ensured by measurements via the analog measurement bus.

For more information about running the system self-test and the test procedures, refer to the R&S TSVP service manual.

## 9.4 Contacting customer support

### Technical support – where and when you need it

For quick, expert help with any Rohde & Schwarz product, contact our customer support center. A team of highly qualified engineers provides support and works with you to find a solution to your query on any aspect of the operation, programming or applications of Rohde & Schwarz products.

### Contact information

Contact our customer support center at [www.rohde-schwarz.com/support](http://www.rohde-schwarz.com/support), or follow this QR code:



Figure 9-1: QR code to the Rohde & Schwarz support page

# Annex

## A Specifications

For an overview of technical specifications of the R&S TS-PIO2 module, refer to the corresponding product brochure / data sheet.

If discrepancies exist between information in this manual and the values in the data sheet, the values in the data sheet take precedence.

## B Block diagrams

Figure B-1 shows the simplified functional block diagram of the Analog/ Digital IO Module R&S TS-PIO2 and the Rear I/O Module R&S TS-PDC in the R&S PowerTSVP.

Figure B-2 shows the block diagram of the Analog/Digital IO Modules R&S TS-PIO2.

Figure B-3 shows the block diagram of the Rear I/O Module R&S TS-PDC.

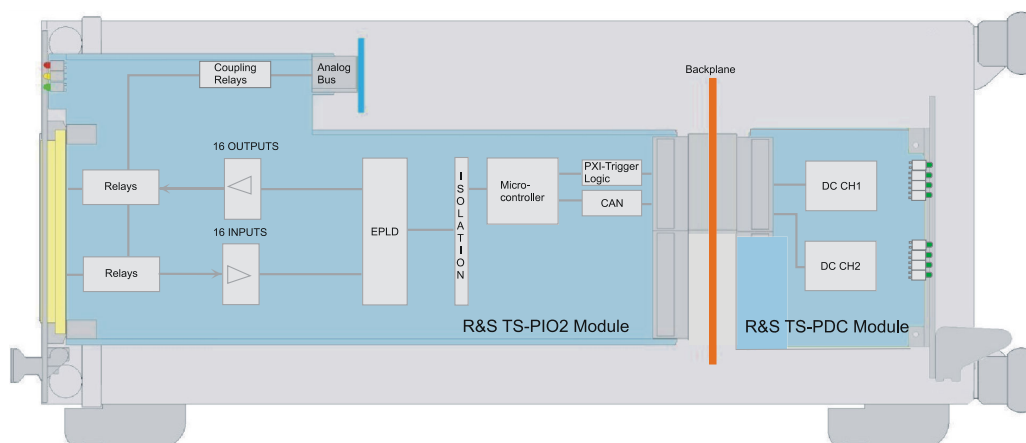

Figure B-1: Functional block diagram of R&S TS-PIO2 with R&S TS-PDC in the R&S PowerTSVP

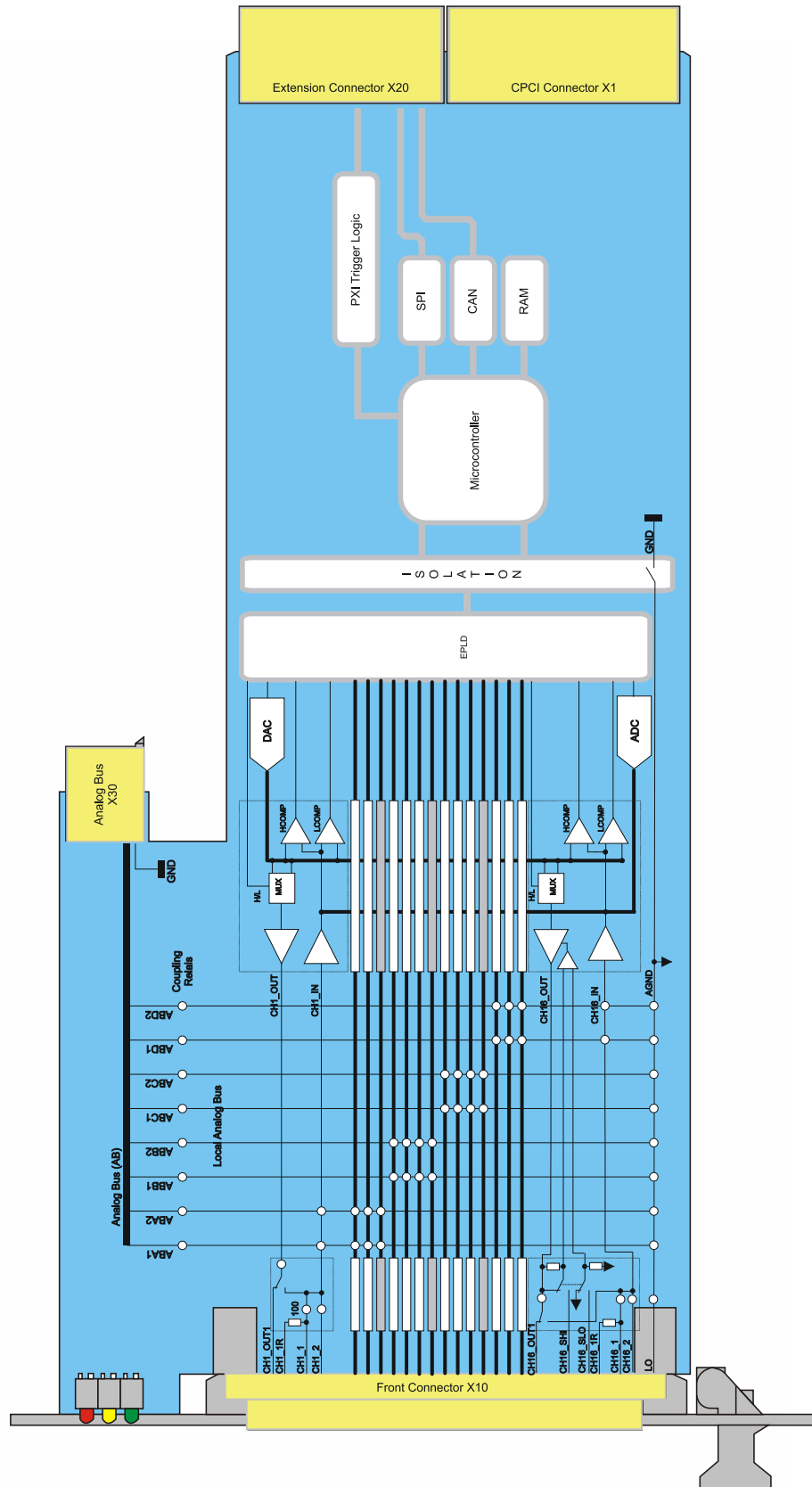

Figure B-2: Block diagram Analog/Digital IO Module R&S TS-PIO2

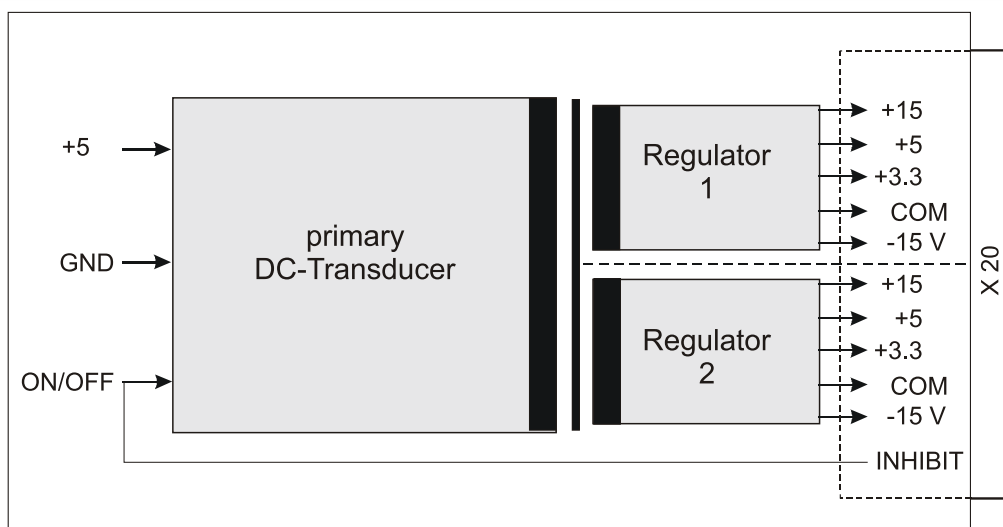

Figure B-3: Block diagram Rear-I/O Modul R&S TS-PDC



## C Interface description

### C.1 R&S TS-PIO2

#### C.1.1 Connector X1

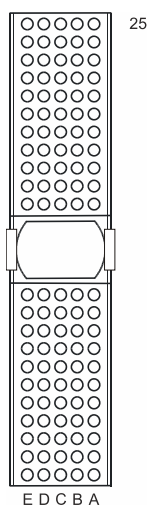

*Figure C-1: Connector X1 (view: plug side)*

Pin	F	E	D	C	B	A
25	GND	+5V				+5V
24	GND				+5V	
23	GND		+5V			
22	GND				GND	
21	GND					
20	GND				GND	
19	GND		GND			
18	GND				GND	
17	GND		GND			
16	GND				GND	
15	GND		GND			
12..14						
11	GND		GND			
10	GND				GND	
9	GND		GND			
8	GND				GND	
7	GND		GND			
6	GND				GND	
5	GND		GND			
4	GND				GND	
3	GND		+5V			
2	GND				+5V	
1	GND	+5V				+5V
Pin	F	E	D	C	B	A

Figure C-2: Pin assignment for connector X1

### C.1.2 Connector X20

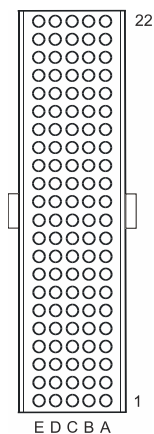

Figure C-3: Connector X20 (view: plug side)

NC = not connected, NP = not populated

Pin	F	E	D	C	B	A
22		GA0	GA1	GA2	GA3	GA4
21					GA5	
20		+5V_IN	GND	+5V_IN		
19				+5V_IN	GND	
18		PXI_TRIG6	CAN_EN	PXI_TRIG5	PXI_TRIG4	PXI_TRIG3
17		PXI_CLK10	+5V_IN	+5V_IN	GND	PXI_TRIG2
16		PXI_TRIG7	GND		PXI_TRIG0	PXI_TRIG1
15			+5V_IN	+5V_IN	GND	
14						
13						
12	NP	+15V_IN	+18.3V_IN	+20V_IN	AGND	+30V_IN
11	NP					
10		-15V_IN			-30V_IN	AGND
9						
8		+15V_IN	+15V_IN	+15V_IN	+15V_IN	+15V_IN
7						
6		-15V_IN	-15V_IN	-15V_IN	-15V_IN	-15V_IN
5						
4						
3			RRST#		GND	RSDO
2			RSDI			RSCLK
1		+5V_IN	CAN L	CAN H	GND	RCS#
Pin	F	E	D	C	B	A

Figure C-4: Pin assignment for connector X20

### C.1.3 Connector X10

Plug type DIN 41612, 96 pin, female

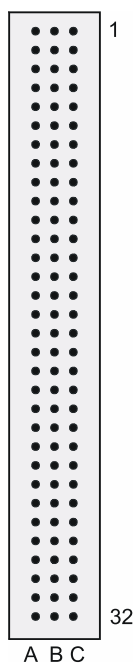

**Figure C-5: Connector X10 (view: front panel)**

**Table C-1: Pin assignment for connector x10 (view front panel)**

	A	B	C
1	CH1_OUT1	CH2_OUT1	CH3_OUT1
2	CH1_1R	CH2_1R	CH3_1R
3	CH1_1	CH2_1	CH3_1
4	CH1_2	CH2_2	CH3_2
5	LO	LO	LO
6	LO	CH4_1	CH4_SHI
7	CH4_OUT1	CH4_2	CH4_SLO
8	CH4_1R	CH6_OUT1	CH7_OUT1
9	CH5_OUT1	CH6_1R	CH7_1R
10	CH5_1R	CH6_1	CH7_1
11	CH5_1	CH6_2	CH7_2
12	CH5_2	LO	LO
13	LO	LO	CH8_SHI
14	CH8_OUT1	CH8_1	CH8_SLO
15	CH8_1R	CH8_2	CH11_OUT1
16	CH9_OUT1	CH10_OUT1	CH11_1R
17	CH9_1R	CH10_1R	CH11_1

	A	B	C
18	CH9_1	CH10_1	CH11_2
19	CH9_2	CH10_2	LO
20	LO	LO	LO
21	CH12_OUT1	CH12_1	CH12_SHI
22	CH12_1R	CH12_2	CH12_SLO
23	CH13_OUT1	CH14_OUT1	CH15_OUT1
24	CH13_1R	CH14_1R	CH15_1R
25	CH13_1	CH14_1	CH15_1
26	CH13_2	CH14_2	CH15_2
27	LO	LO	LO
28	CH16_OUT1	CH16_1	LO
29	CH16_1R	CH16_2	CH16_SHI
30	GND	GND	CH16_SLO
31	GND	GND	GND
32	XTO1	XTI1	CHA_GND



The CHA\_GND signal is connected with the front plate of the module and via two 10 nF capacitors with GND. The front plate itself has no direct connection to GND. When a test object is connected, the test object GND should be connected to GND. To avoid ripple loops, do not connect GND and CHA\_GND.

#### C.1.4 Connector X30

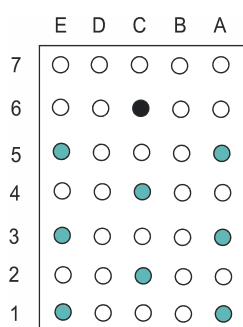

Figure C-6: Connector X30 (mating side)

Table C-2: X30 pinning schedule

Pin	E	D	C	B	A
7					
6			GND		
5	ABC1				ABA1
4			ABB1		
3	ABC2				ABB2
2			ABA2		
1	ABD2				ABD1

## C.2 R&S TS-PDC

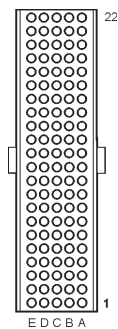

Figure C-7: Connector X20 (R&S TS-PDC mating side)

Pin	Z	A	B	C	D	E	
22	GND						J20
21	GND		GND or NC *3)				
20	GND			+5V *1)	GND	+5V *1)	
19	GND		GND	+5V *1)			
18	GND				GND or NC *4)		
17	GND		GND	+5V *2)	+5V *2)		
16	GND			+5V *2)	GND		
15	GND		GND	+5V *2)	+5V *1)		
14	NC						
13	NC						
12	NP	+15V_1	-15V_1	+5V_1	+3.3V_1	COM_1	
11	NP						
10	NC	+15V_2	-15V_2	+5V_2	+3.3V_2	COM_2	
9	NC						
8	NC	COM_1	COM_1	COM_1	COM_1	COM_1	
7	NC						
6	NC	COM_2	COM_2	COM_2	COM_2	COM_2	
5	NC						
4	NC						
3	GND		GND		RRST#		
2	GND	RSCLK			RSDI		
1	GND	RCS#	GND			+5V *1)	
Pin	Z	A	B	C	D	E	

- \*1) TS-PDC Version 1.0 is supplied via these pins from +5V, for backplanes up to Version 3.x
- \*2) TS-PDC Version 1.1 or higher is supplied via these pins or pins from \*1)
- \*3) TS-PDC Version 1.3 or higher: This pin is not connected
- \*4) TS-PDC Version 1.4 or higher: This pin is not connected

Figure C-8: Pin assignment for connector X20 (R&S TS-PDC)