

Operating Manual

Signal Generator R&S® SM 300

Order No. 1147.1498.03



ROHDE & SCHWARZ

© Copyright 2007

ROHDE & SCHWARZ GmbH & Co. KG
Test and Measurement Division
Mühlendorfstraße 15
81671 München, Germany

9th edition 3/2007
Printed in Germany.
Printed on FFC bleached paper.

Subject to alterations, Errors excepted.
Reprints, also in extracts, are only allowed with written permission of the manufacturer.
All rights reserved.

Chapter Overview

General	Content of the Manual for Signal Generator R&S SM300 Data Sheet Safety Instructions Certificate of Quality EC Certificate of Conformity Support Center Adress List of Rohde & Schwarz Offices
----------------	--

Chapter 1	Introduction
------------------	---------------------

Chapter 2	Control Elements
------------------	-------------------------

Chapter 3	Putting the R&S SM300 into Operation
------------------	---

Chapter 4	Getting Started - Measurement Example
------------------	--

Chapter 5	Manual Operating Concept
------------------	---------------------------------

Chapter 6	Using the R&S SM300
------------------	--------------------------------

Chapter 7	Remote Control/PC Software R&S SM300-K1
------------------	--

Chapter 8	Instrument Interfaces
------------------	------------------------------

Chapter 9	Error Messages
------------------	-----------------------

Chapter 10	Index
-------------------	--------------

Content of the Manual

Introduction

This operating manual provides information about:

- Technical characteristics of the instrument
- Putting into operation
- Basic operating procedures and control elements
- Operation via menus
- Installation and configuration of PC software
- Putting into operation of remote control

By way of an introduction, a typical R&S SM300 setting is described.

The operating manual also contains information about maintenance and troubleshooting based on the warnings and error messages issued by the R&S SM300.

Table of Contents

Chapter Overview	0-3
Content of the Manual.....	0-4
Table of Contents	0-5
Data Sheet	0-11
HF Frequency	0-11
RF Level.....	0-11
LF Generator	0-12
Modulation	0-12
Simultaneous modulation	0-13
Sweep	0-14
Inputs	0-14
Outputs	0-15
Interfaces	0-15
Power Supply.....	0-16
General Data	0-16
Safety Instructions	0-17
Certificate of Quality	0-31
EC Certificate of Conformity	0-32
Support Center Adress	0-33
List of Rohde & Schwarz Offices	0-34
1 Introduction	1-35
1.1 Applications of the R&S SM300	1-35
1.2 Supplied Accessories	1-36
1.3 Warranty	1-36
2 Control Elements	2-37
2.1 Front View	2-37
2.2 Rear View.....	2-38
3 Putting the R&S SM300 into Operation.....	3-39
3.1 Unpacking the R&S SM300.....	3-39
3.2 Setting up the Instrument	3-39
3.3 Connecting the R&S SM300 to the AC Line	3-41
3.4 Switching On the R&S SM300	3-42
3.5 Function Test	3-42
3.6 EMC	3-43
3.7 Connecting an External Keyboard.....	3-44

3.8	Connecting a USB Stick.....	3-45
4	Getting Started.....	4-46
4.1	Level and Frequency Setting.....	4-46
4.1.1	Task	4-46
4.1.2	Setting Steps.....	4-47
5	Manual Operating Concept	5-48
5.1	Making Entries from the Keypad.....	5-48
5.1.1	Numerical Keys.....	5-48
5.1.2	Unit Keys.....	5-48
5.1.3	Rotary Knob	5-49
5.1.4	Cursor Keys	5-49
5.1.5	Function Keys	5-49
5.1.6	Action Keys.....	5-50
5.1.7	SYS Key.....	5-50
5.2	Screen Display.....	5-51
5.2.1	Display Window	5-52
5.2.2	Menu Area	5-53
5.2.3	Function Area.....	5-53
5.3	Calling and Changing Menus	5-54
5.4	Setting Parameters.....	5-56
5.4.1	Direct Selection of Instrument Functions	5-56
5.4.2	Toggling a Setting.....	5-56
5.4.3	Selecting Settings	5-57
5.4.4	Entering Numerical Parameters.....	5-58
5.4.4.1	Entry with the Numerical Keys	5-58
5.4.4.2	Entry using the Cursor Keys and the Rotary Knob	5-60
5.5	Overview of all Menus and Functions	5-62
5.5.1	Signal Generator.....	5-62
5.5.1.1	MAIN Menu.....	5-62
5.5.1.2	MOD Menu	5-63
5.5.1.3	SWEEP Menu.....	5-65
5.5.1.4	FREQ CHAN Menu	5-66
5.5.1.5	LEVEL Menu	5-67
5.5.1.6	SEQUENCE Menu	5-68
5.5.2	SYSTEM Functions.....	5-69
5.5.2.1	PRESET Menu	5-69
5.5.2.2	STATUS Menu	5-69
5.5.2.3	FILE Menu	5-69
5.5.2.4	CONFIG Menu.....	5-69
5.5.2.5	SERVICE Menu.....	5-69
5.5.2.6	INFO Menu	5-70
6	Using the R&S SM300.....	6-71

6.1	Factory Default Settings	6-71
6.2	Signal Generator.....	6-72
6.2.1	Setting of Main Parameters (MAIN menu).....	6-73
6.2.1.1	Configuring the RF Signal	6-74
6.2.1.2	Configuring the LF Signal.....	6-76
6.2.1.2.1	Setting LF Parameters.....	6-77
6.2.1.3	Switching on the Modulation	6-78
6.2.1.4	Loading the Default Setting	6-79
6.2.2	Modulation Settings (MOD menu)	6-80
6.2.2.1	Amplitude Modulation (AM).....	6-81
6.2.2.1.1	Entering the Modulation Depth	6-82
6.2.2.1.2	Setting the Polarity of the Modulation Voltage.....	6-83
6.2.2.1.3	Selecting a Modulation Source	6-84
6.2.2.1.4	Setting the Coupling of the External LF Generator.....	6-84
6.2.2.1.5	Setting the Internal LF Generator Frequency	6-85
6.2.2.1.6	Switching On AM	6-85
6.2.2.2	Frequency Modulation (FM)	6-86
6.2.2.2.1	Entering the Frequency Deviation	6-87
6.2.2.2.2	Setting the Polarity of the Modulation Voltage.....	6-88
6.2.2.2.3	Selecting the Modulation Source	6-89
6.2.2.2.4	Setting the Coupling of the External LF Generator.....	6-89
6.2.2.2.5	Setting the Internal LF Generator Frequency	6-90
6.2.2.2.6	Switching On FM.....	6-90
6.2.2.3	Phase Modulation (ϕ M).....	6-91
6.2.2.3.1	Entering the ϕ M Deviation	6-92
6.2.2.3.2	Setting the Internal LF Generator Frequency	6-93
6.2.2.3.3	Switching on ϕ M	6-93
6.2.2.4	Pulse Modulation (PULSE MOD)	6-94
6.2.2.4.1	Entering the Pulse Off Time.....	6-95
6.2.2.4.2	Entering the Pulse On Time.....	6-95
6.2.2.4.3	Entering the Pulse Delay Time	6-96
6.2.2.4.4	Selecting the Pulse Modulation Source	6-96
6.2.2.4.5	Setting the External Pulse Polarity	6-97
6.2.2.4.6	Switching PULSE MOD On.....	6-97
6.2.2.5	I/Q Modulation	6-98
6.2.3	Sweep Settings (SWEEP Menu)	6-99
6.2.3.1	Signal Generator Frequency Sweep	6-100
6.2.3.1.1	Entering the RF Range	6-101
6.2.3.1.2	Defining the RF Sweep Sequence.....	6-102
6.2.3.1.3	Setting/Starting the RF Sweep Mode	6-104
6.2.3.2	Signal Generator Level Sweep.....	6-106
6.2.3.2.1	Entering the RF level range	6-107
6.2.3.2.2	Defining the Level Sweep Sequence.....	6-108
6.2.3.2.3	Setting/Starting the Level Sweep Mode.....	6-109
6.2.3.3	Frequency Sweep of the Internal LF Generator	6-111
6.2.3.3.1	Entering the LF Range.....	6-112
6.2.3.3.2	Defining the LF Sweep Sequence	6-113
6.2.3.3.3	Setting/Starting the LF Sweep Mode	6-115
6.2.4	Special Frequency Settings (FREQ CHAN Menu)	6-117
6.2.4.1	Entering the Signal Generator Frequency Offset.....	6-118
6.2.4.2	Setting the Step Size for Frequency Entry with the Rotary Knob	6-119
6.2.4.3	Creating Channel Lists	6-120
6.2.4.3.1	Creating/Editing a Channel List	6-122

6.2.4.3.2	Deleting a Channel List.....	6-131
6.2.4.4	Calling the RF Output Frequency from the Channel List	6-132
6.2.4.5	Holding the Current Frequency Setting	6-133
6.2.5	Special Level Settings (LEVEL Menu).....	6-134
6.2.5.1	Entering the Signal Generator Level Offset.....	6-135
6.2.5.2	Setting the Step Size for Level Entry With the Rotary Knob	6-136
6.2.5.3	Converting the Level/Voltage Display	6-136
6.2.5.4	Manual Level Correction.....	6-137
6.2.5.4.1	Creating/Editing a Correction List	6-138
6.2.5.4.2	Deleting a Correction List.....	6-146
6.2.5.4.3	Switching Manual Level Correction On.....	6-147
6.2.6	User-Defined Sequences of Settings (SEQUENCE Menu).....	6-148
6.2.6.1	Saving and Loading User-Defined Settings	6-149
6.2.6.2	Creating a Sequence.....	6-151
6.2.6.2.1	Creating/Editing a sequence List.....	6-152
6.2.6.2.2	Deleting a Sequence List.....	6-160
6.2.6.3	Setting/Starting the Sequence Mode.....	6-161
6.3	SYSTEM Functions (SYS Key)	6-163
6.3.1	Instrument Default Setting (Menu PRESET)	6-165
6.3.1.1	Selecting and Calling the Instrument Default Setting.....	6-166
6.3.2	Displaying the Current Instrument Setting (STATUS Menu)	6-167
6.3.3	User-Defined Settings (FILE Menu).....	6-168
6.3.3.1	Saving and Loading User-Defined Settings	6-169
6.3.3.2	Printing out a Screenshot	6-171
6.3.4	System Settings (CONFIG Menu)	6-174
6.3.4.1	Setting the Date and Time of Day	6-175
6.3.4.2	Selecting an Internal or External Reference Source	6-177
6.3.4.3	Configuring the Instrument Interfaces	6-179
6.3.4.4	Setting the Screen Saver Mode	6-181
6.3.4.5	Selecting an Internal or External Monitor	6-183
6.3.5	Service Functions (SERVICE Menu).....	6-184
6.3.5.1	Performing Selftests	6-184
6.3.6	System Informations (INFO Menu).....	6-185
6.3.6.1	Displaying Module Data.....	6-186
6.3.6.2	Displaying Instrument Statistics	6-186
6.3.6.3	Displaying System Messages	6-187
7	Remote Control/PC Software R&S SM300-K1	7-189
7.1	Applications of PC Software.....	7-189
7.2	Installation and Configuration.....	7-190
7.2.1	Installing the PC Software.....	7-190
7.2.1.1	Installing the Program.....	7-190
7.2.1.2	Installing the Device Drivers	7-194
7.2.1.2.1	Installing Steps for Windows™ 2000	7-194
7.2.1.2.2	Installing Steps for Windows™ XP.....	7-198
7.2.2	Connecting the PC-Software with the R&S SM300	7-201
7.2.2.1	Starting the Series 300 Software Manager	7-201

7.2.2.2	Creating the Program Version	7-202
7.2.3	Uninstalling the PC Software	7-203
7.2.4	Update PC Software	7-204
7.3	Starting the Remote Control.....	7-206
7.3.1	Connecting the Instrument to the PC.....	7-206
7.3.2	Starting the Program.....	7-207
7.3.3	Closing the Remote Control.....	7-209
7.4	Getting Started.....	7-210
7.5	Control Concept.....	7-212
7.5.1	PC Monitor Display	7-212
7.5.1.1	Diagram	7-213
7.5.1.2	Menus.....	7-213
7.5.1.3	Functions	7-214
7.5.2	Setting the Parameters	7-215
7.6	Overview of all Menus and Functions (Shortcuts).....	7-216
7.6.1	File	7-216
7.6.2	Function	7-216
7.6.2.1	Main	7-217
7.6.2.2	Modulation	7-218
7.6.2.2.1	Amplitude Modulation	7-219
7.6.2.2.2	Frequency Modulation	7-220
7.6.2.2.3	Phase Modulation	7-221
7.6.2.2.4	Pulse Modulation	7-222
7.6.2.3	Sweep.....	7-223
7.6.2.3.1	Configuring the Frequency Sweep	7-224
7.6.2.3.2	Configuring the Level Sweep.....	7-225
7.6.2.3.3	Configuring the Frequency Sweep of the Internal LF Generator.....	7-226
7.6.2.4	Freq/Chan.....	7-227
7.6.2.4.1	Entering Channel Lists.....	7-228
7.6.2.4.2	Inserting/Editing a List Entry	7-229
7.6.2.4.3	Deleting a List Entry	7-229
7.6.2.5	Level	7-230
7.6.2.5.1	Entering Correction Lists.....	7-231
7.6.2.5.2	Inserting/Editing a List Entry	7-232
7.6.2.5.3	Deleting a List Entry	7-232
7.6.2.6	Sequence	7-233
7.6.2.6.1	Creating a Sequence List.....	7-234
7.6.2.6.2	Inserting/Editing a List Entry	7-235
7.6.2.6.3	Deleting a List Entry	7-235
7.6.3	? Help.....	7-236
8	Instrument Interfaces	8-237
8.1	Keyboard Connector (KEYB).....	8-237
8.2	Monitor Connector (MON).....	8-237
8.3	Reference Input and Output (EXT REF IN, REF OUT).....	8-238
8.4	USB Interface (PC, DEV)	8-238
9	Error Messages	9-239

9.1 System Messages **9-239**
9.2 Warnings Indicating Impermissible Operating States **9-240**
10 Index **10-241**

Data Sheet

For the R&S SM300 a calibration cycle of 1 year is recommended.

NOTE

As a highly innovative company, we continuously refine our products. Please check our homepage www.sm300.rohde-schwarz.com for new applications and features.

HF Frequency

Frequency range		9 kHz to 3 GHz
Setting resolution		0.1 Hz
Setting time	for an offset of $< 1 \cdot 10^{-7}$	< 10 ms
Reference frequency		10 MHz
Aging		$< 2 \cdot 10^{-6}$ /year
Temperature drift	5 °C to 45 °C	$< 1 \cdot 10^{-6}$
Spectral purity		
Spurious		
Harmonics	level ≤ 0 dBm, $f_c > 1$ MHz	< -30 dBc
Subharmonics	$f_c > 1$ MHz	< -50 dBc
Nonharmonics	> 10 kHz from carrier	< -50 dBc
Wideband noise	$f_c = 1$ GHz, carrier offset > 2 MHz	< -123 dBc (1 Hz)
Single-sideband phase noise	$f_c = 1$ GHz, carrier offset 20 kHz,	< -95 dBc (1 Hz)
Residual FM	$f_c = 1$ GHz	
	0.3 Hz bis 3 kHz	< 10 Hz rms < 30 Hz peak
	0.03 kHz bis 20 kHz	< 60 Hz rms < 300 Hz peak
Residual AM		
	0.3 kHz bis 3 kHz	< 0.03 % rms < 0.2 % peak

RF Level

Level range		-127 dBm to +13 dBm
Setting time	to < 0.3 dB deviation	< 200 ms
Setting resolution		0.1 dB
Level uncertainty	$f_c > 100$ kHz, level > -120 dBm, 20 °C to 30 °C	< 1 dB

LF Generator

Frequency range		20 Hz to 80 kHz
Frequency resolution		0.1 Hz
Frequency response	20 Hz to 20 kHz	< 0.2 dB
Total harmonic distortion	20 Hz to 20 kHz	< 0.1 %

Modulation

Amplitude modulation		
Operating modes		internal, external AC/DC
Modulation depth	the modulation depth that can be set observing the AM specifications continuously decreases from +7 dBm to +13 dBm	0 % to 100 %
Resolution		0.1 %
Setting uncertainty	$f_{LF} = 1 \text{ kHz}$, $m < 80 \%$, level = 0 dBm	< 5 % of setting + 0.2 %
AM total harmonic distortion	$f_{LF} = 1 \text{ kHz}$, $m < 80 \%$, level = 0 dBm	< 2 %
Modulation frequency range		DC/20 Hz to 20 kHz
Frequency modulation		
Operating modes		internal, external AC/DC
Frequency deviation		20 Hz to 100 kHz
Resolution		< 1 %
Setting uncertainty	$f_{LF} = 1 \text{ kHz}$	< 5 % of setting + 300 Hz
FM total harmonic distortion	$f_{LF} = 1 \text{ kHz}$, deviation = 50 kHz	< 1 %
Carrier frequency deviation	external	< 200 Hz
Modulation frequency range		DC/20 Hz bis 80 kHz
Phase modulation		
Operating modes		internal
Phase deviation	$f_{LF} \leq 10 \text{ kHz}$ $10 \text{ kHz} < f_{LF} \leq 20 \text{ kHz}$	0 to 10 rad 0 to 5 rad
Resolution		< 1 %, min. 0.001 rad
Setting uncertainty	$f_{LF} = 1 \text{ kHz}$	< 5 % of setting + 0.2 rad
ϕ M total harmonic distortion	$f_{LF} = 1 \text{ kHz}$, deviation = 5 rad	< 1.5 %
Modulation frequency range		300 Hz to 20 kHz

I/Q modulation		
Operating modes		external
Modulation frequency range (3 dB)		DC to 40 MHz
Carrier suppression		typ. 40 dB
ACLR	WCDMA 3GPP FDD (test model 1, 64 DPCHs) offset 5 MHz offset 10 MHz	typ. 54 dB typ. 55 dB
Composite EVM	WCDMA 3GPP FDD (test model 1, 64 DPCHs)	typ. 3.3 %
Phase uncertainty	GSM	typ. 1.2 °
Pulse modulation/Pulse generator		
Operating modes		external, internal
Rise/fall time (10 %/90 %)		< 3 µs
Delay time (external)		100 µs to 1 s
Pulse width (internal)		100 µs to 1 s
Pulse period (internal)		200 µs to 2 s
Time resolution		1 µs

Simultaneous modulation

	AM int	AM ext	I/Q	FM int	FM ext	φM	Pulse int	Pulse ext
AM int	-	✓	-	☑	☑	☑	-	-
AM ext	✓	-	-	☑	☑	☑	-	-
I/Q	-	-	-	☑	☑	☑	✓	✓
FM int	☑	☑	☑	-	✓	-	✓	✓
FM ext	☑	☑	☑	-	-	-	✓	✓
φM	☑	☑	☑	-	-	-	✓	✓
Pulse int	-	-	✓	✓	✓	✓	-	-
Pulse ext	-	-	✓	✓	✓	✓	-	-

Combinations marked with ☑ are not visible on the operating menu.

Sweep

RF sweep, LF sweep		
Operating modes		continuous sweep, single sweep, single step
Sweep range		LF: 20 Hz to 80 kHz RF: 9 kHz to 3 GHz
Step width (log)		0.01 % to 100 %
Step width (lin)		LF: 0.1 Hz to 80 kHz RF: 0.1 Hz to 1 GHz
Level sweep		
Operating modes		continuous sweep, single sweep, single step
Sweep range		-127dBm to +13 dBm
Step width		0.1 dB to 20 dB
Step time		10 ms to 1 s

Inputs

Reference frequency input		
Connector		BNC female
Reference frequency		10 MHz, 5 MHz, 2 MHz
Input voltage		0.5 V to 2 V
Input impedance		50 Ω
AM/FM modulator input		
Connector		BNC female
Input voltage for max. modulation depth or modulation deviation		1 V
Input impedance		> 100 k Ω
I/Q modulator inputs		
I/Q inputs		BNC female
Input impedance		50 Ω
Input voltage		$\sqrt{U_I^2 + U_Q^2} = 0.5 \text{ V}$
VSWR		< 1.5
Pulse modulator input		
Connector		BNC female
Input voltage		TTL voltages

Outputs

RF output		
Connector		N female on front panel
Characteristic impedance		50 Ω
VSWR	1 MHz < f_c \leq 3 GHz	< 1.8
Max. permissible RF power	1 minute	+36 dBm
Max. permissible DC voltage		30 V
LF output		
Connector		BNC female on front panel
Output voltage		1 mV to 2 V rms, into 50 Ω
Output voltage resolution		< 1 %, 1 mV minimum resolution
Spurious suppression		< -60 dBc
Reference frequency output		
Connector		BNC female
Reference frequency		10 MHz
Output voltage		> 0.5 V into 50 Ω

Interfaces

USB host		
Connector		A plug
Protocol		version 1.1
USB interface		
Connector		B plug
Protocol		version 1.1
Command set	device-specific, remote control via supplied Windows driver (Windows 2000/XP™)	

Power Supply

Input voltage range		100 V to 240 V (AC), 50 Hz to 60 Hz, autoranging
Power consumption		< 35 VA

General Data

Display		
Type		5.4" active colour TFT display
Resolution		320 x 240 pixels
Memory locations		
Device setups		10
Ambient conditions		
Operating temperature range	meets DIN EN 60068-2-1/2	+5 °C to +45 °C
Storage temperature range		-20 °C to +70 °C
Relative humidity	meets DIN EN 60068-2-78 (no moisture condensation)	95 % at +40 °C
Mechanical resistance		
Vibration, sinusoidal	meets DIN EN 60068-2-6, DIN EN 61010-1 and MIL-T-28800D class 5	5 Hz to 150 Hz: max. 2g at 55 Hz, 55 Hz to 150 Hz: 0.5g constant
Vibration, random	meets DIN EN 60068-2-64	10 Hz to 500 Hz: 1.9g
Shock	meets DIN EN 60068-2-27 and MIL STD 810	shock spectrum
Electromagnetic compatibility	meets EN 55011 class B and EN 61326 (EMC Direktive 89/336/EEC)	
EMI field strength		< 10 V/m
Protection class	DIN EN 61010-1/IEC61010-1 UL3111-1; CSA22.2 No:1010.1	
Dimensions (W x H x D)		219 mm x 147 mm x 350 mm
Weight		approx. 7 kg



Before putting the product into operation for the first time, make sure to read the following

Safety Instructions



All plants and locations of the Rohde & Schwarz group of companies make every effort to keep the safety standard of our products up to date and to offer our customers the highest possible degree of safety. Our products and the auxiliary equipment required for them are designed and tested in accordance with the relevant safety standards. Compliance with these standards is continuously monitored by our quality assurance system. The product described here has been designed and tested in accordance with the EC Certificate of Conformity and has left the manufacturer's plant in a condition fully complying with safety standards. To maintain this condition and to ensure safe operation, observe all instructions and warnings provided in this manual. If you have any questions regarding these safety instructions, the Rohde & Schwarz group of companies will be happy to answer them.

Furthermore, it is your responsibility to use the product in an appropriate manner. This product is designed for use solely in industrial and laboratory environments or in the field and must not be used in any way that may cause personal injury or property damage. You are responsible if the product is used for an intention other than its designated purpose or in disregard of the manufacturer's instructions. The manufacturer shall assume no responsibility for such use of the product.

The product is used for its designated purpose if it is used in accordance with its product documentation and within its performance limits (see data sheet, documentation, the following safety instructions). Using the product requires technical skills and a basic knowledge of English. It is therefore essential that the product be used exclusively by skilled and specialized staff or thoroughly trained personnel with the required skills. If personal safety gear is required for using Rohde & Schwarz products, this will be indicated at the appropriate place in the product documentation.

Symbols and safety labels

Observe product documentation	Weight indication for units >18 kg	Danger of electric shock	Warning! Hot surface	PE terminal	Ground	Ground terminal	Attention! Electrostatic sensitive devices

Supply voltage ON/OFF	Standby indication	Direct current (DC)	Alternating current (AC)	Direct/alternating current (DC/AC)	Device fully protected by double/reinforced insulation

Safety Instructions

Observing the safety instructions will help prevent personal injury or damage of any kind caused by dangerous situations. Therefore, carefully read through and adhere to the following safety instructions before putting the product into operation. It is also absolutely essential to observe the additional safety instructions on personal safety that appear in relevant parts of the product documentation. In these safety instructions, the word "product" refers to all merchandise sold and distributed by the Rohde & Schwarz group of companies, including instruments, systems and all accessories.

Tags and their meaning

DANGER	This tag indicates a definite hazard carrying a high risk of death or serious injury if not avoided.
WARNING	This tag indicates a possible hazard carrying a medium risk of death or (serious) injury if not avoided.
CAUTION	This tag indicates a hazard carrying a low risk of minor or moderate injury if not avoided.
ATTENTION	This tag indicates the possibility of incorrect use that can cause damage to the product.
NOTE	This tag indicates a situation where the user should pay special attention to operating the product but which does not lead to damage.

These tags are in accordance with the standard definition for civil applications in the European Economic Area. Definitions that deviate from the standard definition may also exist in other economic areas or military applications. It is therefore essential to make sure that the tags described here are always used only in connection with the related product documentation and the related product. The use of tags in connection with unrelated products or documentation can result in misinterpretation and thus contribute to personal injury or material damage.

Basic safety instructions

- The product may be operated only under the operating conditions and in the positions specified by the manufacturer. Its ventilation must not be obstructed during operation. Unless otherwise specified, the following requirements apply to Rohde & Schwarz products:
prescribed operating position is always with the housing floor facing down, IP protection 2X,
pollution severity 2, overvoltage category 2, use only in enclosed spaces, max. operation altitude 2000 m above sea level, max. transport altitude 4500 m above sea level.
Unless specified otherwise in the data sheet, a tolerance of $\pm 10\%$ shall apply to the nominal voltage and of $\pm 5\%$ to the nominal frequency.

Safety Instructions

2. Applicable local or national safety regulations and rules for the prevention of accidents must be observed in all work performed. The product may be opened only by authorized, specially trained personnel. Prior to performing any work on the product or opening the product, the product must be disconnected from the supply network. Any adjustments, replacements of parts, maintenance or repair must be carried out only by technical personnel authorized by Rohde & Schwarz. Only original parts may be used for replacing parts relevant to safety (e.g. power switches, power transformers, fuses). A safety test must always be performed after parts relevant to safety have been replaced (visual inspection, PE conductor test, insulation resistance measurement, leakage current measurement, functional test).
3. As with all industrially manufactured goods, the use of substances that induce an allergic reaction (allergens, e.g. nickel) such as aluminum cannot be generally excluded. If you develop an allergic reaction (such as a skin rash, frequent sneezing, red eyes or respiratory difficulties), consult a physician immediately to determine the cause.
4. If products/components are mechanically and/or thermally processed in a manner that goes beyond their intended use, hazardous substances (heavy-metal dust such as lead, beryllium, nickel) may be released. For this reason, the product may only be disassembled, e.g. for disposal purposes, by specially trained personnel. Improper disassembly may be hazardous to your health. National waste disposal regulations must be observed.
5. If handling the product yields hazardous substances or fuels that must be disposed of in a special way, e.g. coolants or engine oils that must be replenished regularly, the safety instructions of the manufacturer of the hazardous substances or fuels and the applicable regional waste disposal regulations must be observed. Also observe the relevant safety instructions in the product documentation.
6. Depending on the function, certain products such as RF radio equipment can produce an elevated level of electromagnetic radiation. Considering that unborn life requires increased protection, pregnant women should be protected by appropriate measures. Persons with pacemakers may also be endangered by electromagnetic radiation. The employer/operator is required to assess workplaces where there is a special risk of exposure to radiation and, if necessary, take measures to avert the danger.
7. Operating the products requires special training and intense concentration. Make certain that persons who use the products are physically, mentally and emotionally fit enough to handle operating the products; otherwise injuries or material damage may occur. It is the responsibility of the employer to select suitable personnel for operating the products.
8. Prior to switching on the product, it must be ensured that the nominal voltage setting on the product matches the nominal voltage of the AC supply network. If a different voltage is to be set, the power fuse of the product may have to be changed accordingly.

Safety Instructions

9. In the case of products of safety class I with movable power cord and connector, operation is permitted only on sockets with earthing contact and protective earth connection.
10. Intentionally breaking the protective earth connection either in the feed line or in the product itself is not permitted. Doing so can result in the danger of an electric shock from the product. If extension cords or connector strips are implemented, they must be checked on a regular basis to ensure that they are safe to use.
11. If the product has no power switch for disconnection from the AC supply, the plug of the connecting cable is regarded as the disconnecting device. In such cases, it must be ensured that the power plug is easily reachable and accessible at all times (corresponding to the length of connecting cable, approx. 2 m). Functional or electronic switches are not suitable for providing disconnection from the AC supply. If products without power switches are integrated in racks or systems, a disconnecting device must be provided at the system level.
12. Never use the product if the power cable is damaged. Check the power cable on a regular basis to ensure that it is in proper operating condition. By taking appropriate safety measures and carefully laying the power cable, ensure that the cable cannot be damaged and that no one can be hurt by e.g. tripping over the cable or suffering an electric shock.
13. The product may be operated only from TN/TT supply networks fused with max. 16 A (higher fuse only after consulting with the Rohde & Schwarz group of companies).
14. Do not insert the plug into sockets that are dusty or dirty. Insert the plug firmly and all the way into the socket. Otherwise, this can result in sparks, fire and/or injuries.
15. Do not overload any sockets, extension cords or connector strips; doing so can cause fire or electric shocks.
16. For measurements in circuits with voltages $V_{\text{rms}} > 30 \text{ V}$, suitable measures (e.g. appropriate measuring equipment, fusing, current limiting, electrical separation, insulation) should be taken to avoid any hazards.
17. Ensure that the connections with information technology equipment comply with IEC 950/EN 60950.
18. Unless expressly permitted, never remove the cover or any part of the housing while the product is in operation. Doing so will expose circuits and components and can lead to injuries, fire or damage to the product.
19. If a product is to be permanently installed, the connection between the PE terminal on site and the product's PE conductor must be made first before any other connection is made. The product may be installed and connected only by a license electrician.
20. For permanently installed equipment without built-in fuses, circuit breakers or similar protective devices, the supply circuit must be fused in such a way that suitable protection is provided for users and products.
21. Do not insert any objects into the openings in the housing that are not designed for this purpose. Never pour any liquids onto or into the housing. This can cause short circuits inside the product and/or electric shocks, fire or injuries.

Safety Instructions

22. Use suitable overvoltage protection to ensure that no overvoltage (such as that caused by a thunderstorm) can reach the product. Otherwise the operating personnel will be endangered by electric shocks.
23. Rohde & Schwarz products are not protected against penetration of water, unless otherwise specified (see also safety instruction 1.). If this is not taken into account, there exists the danger of electric shock for the user or damage to the product, which can also lead to personal injury.
24. Never use the product under conditions in which condensation has formed or can form in or on the product, e.g. if the product was moved from a cold to a warm environment.
25. Do not close any slots or openings on the product, since they are necessary for ventilation and prevent the product from overheating. Do not place the product on soft surfaces such as sofas or rugs or inside a closed housing, unless this is well ventilated.
26. Do not place the product on heat-generating devices such as radiators or fan heaters. The temperature of the environment must not exceed the maximum temperature specified in the data sheet.
27. Batteries and storage batteries must not be exposed to high temperatures or fire. Keep batteries and storage batteries away from children. Do not short-circuit batteries and storage batteries.
If batteries or storage batteries are improperly replaced, this can cause an explosion (warning: lithium cells).
- Replace the battery or storage battery only with the matching Rohde & Schwarz type (see spare parts list). Batteries and storage batteries must be recycled and kept separate from residual waste. Batteries and storage batteries that contain lead, mercury or cadmium are hazardous waste. Observe the national regulations regarding waste disposal and recycling.
28. Please be aware that in the event of a fire, toxic substances (gases, liquids etc.) that may be hazardous to your health may escape from the product.
29. The product can be very heavy. Be careful when moving it to avoid back or other physical injuries.
30. Do not place the product on surfaces, vehicles, cabinets or tables that for reasons of weight or stability are unsuitable for this purpose. Always follow the manufacturer's installation instructions when installing the product and fastening it to objects or structures (e.g. walls and shelves).
31. Handles on the products are designed exclusively for personnel to hold or carry the product. It is therefore not permissible to use handles for fastening the product to or on means of transport such as cranes, fork lifts, wagons, etc. The user is responsible for securely fastening the products to or on the means of transport and for observing the safety regulations of the manufacturer of the means of transport. Noncompliance can result in personal injury or material damage.

Safety Instructions

32. If you use the product in a vehicle, it is the sole responsibility of the driver to drive the vehicle safely. Adequately secure the product in the vehicle to prevent injuries or other damage in the event of an accident. Never use the product in a moving vehicle if doing so could distract the driver of the vehicle. The driver is always responsible for the safety of the vehicle. The manufacturer assumes no responsibility for accidents or collisions.
33. If a laser product (e.g. a CD/DVD drive) is integrated in a Rohde & Schwarz product, do not use any other settings or functions than those described in the product documentation. Otherwise this may be hazardous to your health, since the laser beam can cause irreversible damage to your eyes. Never try to take such products apart, and never look into the laser beam.



Por favor lea imprescindiblemente antes de la primera puesta en funcionamiento las siguientes











Informaciones de seguridad







El principio del grupo de empresas Rohde & Schwarz consiste en tener nuestros productos siempre al día con los standards de seguridad y de ofrecer a nuestros clientes el máximo grado de seguridad. Nuestros productos y todos los equipos adicionales son siempre fabricados y examinados según las normas de seguridad vigentes. Nuestra sección de gestión de la seguridad de calidad controla constantemente que sean cumplidas estas normas. El presente producto ha sido fabricado y examinado según el comprobante de conformidad adjunto según las normas de la CE y ha salido de nuestra planta en estado impecable según los standards técnicos de seguridad. Para poder preservar este estado y garantizar un funcionamiento libre de peligros, el usuario deberá atenerse a todas las informaciones, informaciones de seguridad y notas de alerta. El grupo de empresas Rohde & Schwarz está siempre a su disposición en caso de que tengan preguntas referentes a estas informaciones de seguridad.

Además queda en la responsabilidad del usuario utilizar el producto en la forma debida. Este producto solamente fue elaborado para ser utilizado en la industria y el laboratorio o para fines de campo y de ninguna manera deberá ser utilizado de modo que alguna persona/cosa pueda ser dañada. El uso del producto fuera de sus fines definidos o despreciando las informaciones de seguridad del fabricante queda en la responsabilidad del usuario. El fabricante no se hace en ninguna forma responsable de consecuencias a causa del mal uso del producto.

Se parte del uso correcto del producto para los fines definidos si el producto es utilizado dentro de las instrucciones de la correspondiente documentación de producto y dentro del margen de rendimiento definido (ver hoja de datos, documentación, informaciones de seguridad que siguen). El uso del producto hace necesarios conocimientos profundos y conocimientos parciales del idioma inglés. Por eso se deberá tener en cuenta de exclusivamente autorizar para el uso del producto a personas peritas o debidamente minuciosamente instruidas con los conocimientos citados. Si fuera necesaria indumentaria de seguridad para el uso de productos de R&S, encontrará la información debida en la documentación del producto en el capítulo correspondiente.

Símbolos y definiciones de seguridad

							
Ver documentación de producto	Informaciones para maquinaria con un peso de > 18kg	Peligro de golpe de corriente	¡Advertencia! Superficie caliente	Conexión a conductor protector	Conexión a tierra	Conexión a masa conductora	¡Cuidado! Elementos de construcción con peligro de carga electrostática

					
potencia EN MARCHA/PARADA	Indicación Stand-by	Corriente continua DC	Corriente alterna AC	Corriente continua/alterna DC/AC	El aparato está protegido en su totalidad por un aislamiento de doble refuerzo

Tener en cuenta las informaciones de seguridad sirve para tratar de evitar daños y peligros de toda clase. Es necesario de que se lean las siguientes informaciones de seguridad concienzudamente y se tengan en cuenta debidamente antes de la puesta en funcionamiento del producto. También deberán ser tenidas en cuenta las informaciones para la protección de personas que encontrarán en el capítulo correspondiente de la documentación de producto y que también son obligatorias de seguir. En las informaciones de seguridad actuales hemos juntado todos los objetos vendidos por el grupo de empresas Rohde & Schwarz bajo la denominación de „producto“, entre ellos también aparatos, instalaciones así como toda clase de accesorios.

Palabras de señal y su significado

- PELIGRO** Identifica un peligro directo con riesgo elevado de provocar muerte o lesiones de gravedad si no se toman las medidas oportunas.
- ADVERTENCIA** Identifica un posible peligro con riesgo medio de provocar muerte o lesiones (de gravedad) si no se toman las medidas oportunas.
- ATENCIÓN** Identifica un peligro con riesgo reducido de provocar lesiones de gravedad media o leve si no se toman las medidas oportunas.
- CUIDADO** Indica la posibilidad de utilizar mal el producto y a consecuencia dañarlo.
- INFORMACIÓN** Indica una situación en la que deberían seguirse las instrucciones en el uso del producto, pero que no consecuentemente deben de llevar a un daño del mismo.

Informaciones de seguridad

Las palabras de señal corresponden a la definición habitual para aplicaciones civiles en el área económica europea. Pueden existir definiciones diferentes a esta definición en otras áreas económicas o en aplicaciones militares. Por eso se deberá tener en cuenta que las palabras de señal aquí descritas sean utilizadas siempre solamente en combinación con la correspondiente documentación de producto y solamente en combinación con el producto correspondiente. La utilización de las palabras de señal en combinación con productos o documentaciones que no les correspondan puede llevar a malinterpretaciones y tener por consecuencia daños en personas u objetos.

Informaciones de seguridad elementales

1. El producto solamente debe ser utilizado según lo indicado por el fabricante referente a la situación y posición de funcionamiento sin que se obstruya la ventilación. Si no se convino de otra manera, es para los productos R&S válido lo que sigue: como posición de funcionamiento se define principalmente la posición con el suelo de la caja para abajo, modo de protección IP 2X, grado de suciedad 2, categoría de sobrecarga eléctrica 2, utilizar solamente en estancias interiores, utilización hasta 2000 m sobre el nivel del mar, transporte hasta 4.500 m sobre el nivel del mar.
A menos que se especifique otra cosa en la hoja de datos, se aplicará una tolerancia de $\pm 10\%$ sobre el voltaje nominal y de $\pm 5\%$ sobre la frecuencia nominal.
2. En todos los trabajos deberán ser tenidas en cuenta las normas locales de seguridad de trabajo y de prevención de accidentes. El producto solamente debe de ser abierto por personal perito autorizado. Antes de efectuar trabajos en el producto o abrirlo deberá este ser desconectado de la corriente. El ajuste, el cambio de partes, la manutención y la reparación deberán ser solamente efectuadas por electricistas autorizados por R&S. Si se reponen partes con importancia para los aspectos de seguridad (por ejemplo el enchufe, los transformadores o los fusibles), solamente podrán ser sustituidos por partes originales. Después de cada recambio de partes elementales para la seguridad deberá ser efectuado un control de seguridad (control a primera vista, control de conductor protector, medición de resistencia de aislamiento, medición de medición de la corriente conductora, control de funcionamiento).
3. Como en todo producto de fabricación industrial no puede ser excluido en general de que se produzcan al usarlo elementos que puedan generar alergias, los llamados elementos alergénicos (por ejemplo el níquel). Si se produjeran en el trato con productos R&S reacciones alérgicas, como por ejemplo urticaria, estornudos frecuentes, irritación de la conjuntiva o dificultades al respirar, se deberá consultar inmediatamente a un médico para averiguar los motivos de estas reacciones.

Informaciones de seguridad

4. Si productos / elementos de construcción son tratados fuera del funcionamiento definido de forma mecánica o térmica, pueden generarse elementos peligrosos (polvos de sustancia de metales pesados como por ejemplo plomo, berilio, níquel). La partición elemental del producto, como por ejemplo sucede en el tratamiento de materias residuales, debe de ser efectuada solamente por personal especializado para estos tratamientos. La partición elemental efectuada inadecuadamente puede generar daños para la salud. Se deben tener en cuenta las directivas nacionales referentes al tratamiento de materias residuales.
5. En el caso de que se produjeran agentes de peligro o combustibles en la aplicación del producto que debieran de ser transferidos a un tratamiento de materias residuales, como por ejemplo agentes refrigerantes que deben ser repuestos en periodos definidos, o aceites para motores, deberán ser tenidas en cuenta las prescripciones de seguridad del fabricante de estos agentes de peligro o combustibles y las regulaciones regionales para el tratamiento de materias residuales. Cuiden también de tener en cuenta en caso dado las prescripciones de seguridad especiales en la descripción del producto.
6. Ciertos productos, como por ejemplo las instalaciones de radiación HF, pueden a causa de su función natural, emitir una radiación electromagnética aumentada. En vista a la protección de la vida en desarrollo deberían ser protegidas personas embarazadas debidamente. También las personas con un bypass pueden correr peligro a causa de la radiación electromagnética. El empresario/usuario está comprometido a valorar y señalar áreas de trabajo en las que se corra un riesgo aumentado de exposición a radiaciones para evitar riesgos.
7. La utilización de los productos requiere instrucciones especiales y una alta concentración en el manejo. Debe de ponerse por seguro de que las personas que manejen los productos estén a la altura de los requerimientos necesarios referente a sus aptitudes físicas, psíquicas y emocionales, ya que de otra manera no se pueden excluir lesiones o daños de objetos. El empresario lleva la responsabilidad de seleccionar el personal usuario apto para el manejo de los productos.
8. Antes de la puesta en marcha del producto se deberá tener por seguro de que la tensión preseleccionada en el producto equivalga a la del la red de distribución. Si es necesario cambiar la preselección de la tensión también se deberán en caso dabo cambiar los fusibles correspondientes del prodcuto.
9. Productos de la clase de seguridad I con alimentación móvil y enchufe individual de producto solamente deberán ser conectados para el funcionamiento a tomas de corriente de contacto de seguridad y con conductor protector conectado.
10. Queda prohibida toda clase de interrupción intencionada del conductor protector, tanto en la toma de corriente como en el mismo producto. Puede tener como consecuencia el peligro de golpe de corriente por el producto. Si se utilizaran cables o enchufes de extensión se deberá poner al seguro, que es controlado su estado técnico de seguridad.

Informaciones de seguridad

11. Si el producto no está equipado con un interruptor para desconectarlo de la red, se deberá considerar el enchufe del cable de distribución como interruptor. En estos casos deberá asegurarse de que el enchufe sea de fácil acceso y nabejo (según la medida del cable de distribución, aproximadamente 2 m). Los interruptores de función o electrónicos no son aptos para el corte de la red eléctrica. Si los productos sin interruptor están integrados en construcciones o instalaciones, se deberá instalar el interruptor al nivel de la instalación.
12. No utilice nunca el producto si está dañado el cable eléctrico. Compruebe regularmente el correcto estado de los cables de conexión a red. Asegure a través de las medidas de protección y de instalación adecuadas de que el cable de eléctrico no pueda ser dañado o de que nadie pueda ser dañado por él, por ejemplo al tropezar o por un golpe de corriente.
13. Solamente está permitido el funcionamiento en redes de distribución TN/TT aseguradas con fusibles de como máximo 16 A (utilización de fusibles de mayor amperaje sólo previa consulta con el grupo de empresas Rohde & Schwarz).
14. Nunca conecte el enchufe en tomas de corriente sucias o llenas de polvo. Introduzca el enchufe por completo y fuertemente en la toma de corriente. Si no tiene en consideración estas indicaciones se arriesga a que se originen chispas, fuego y/o heridas.
15. No sobrecargue las tomas de corriente, los cables de extensión o los enchufes de extensión ya que esto pudiera causar fuego o golpes de corriente.
16. En las mediciones en circuitos de corriente con una tensión de entrada de $U_{\text{eff}} > 30 \text{ V}$ se deberá tomar las precauciones debidas para impedir cualquier peligro (por ejemplo medios de medición adecuados, seguros, limitación de tensión, corte protector, aislamiento etc.).
17. En caso de conexión con aparatos de la técnica informática se deberá tener en cuenta que estos cumplan los requisitos de la EC950/EN60950.
18. A menos que esté permitido expresamente, no retire nunca la tapa ni componentes de la carcasa mientras el producto esté en servicio. Esto pone a descubierto los cables y componentes eléctricos y puede causar heridas, fuego o daños en el producto.
19. Si un producto es instalado fijamente en un lugar, se deberá primero conectar el conductor protector fijo con el conductor protector del aparato antes de hacer cualquier otra conexión. La instalación y la conexión deberán ser efectuadas por un electricista especializado.
20. En caso de que los productos que son instalados fijamente en un lugar sean sin protector implementado, autointerruptor o similares objetos de protección, el circuito de suministro de corriente deberá estar protegido de manera que usuarios y productos estén suficientemente protegidos.
21. Por favor, no introduzca ningún objeto que no esté destinado a ello en los orificios de la caja del aparato. No vierta nunca ninguna clase de líquidos sobre o en la caja. Esto puede producir corto circuitos en el producto y/o puede causar golpes de corriente, fuego o heridas.

Informaciones de seguridad

22. Asegúrese con la protección adecuada de que no pueda originarse en el producto una sobrecarga por ejemplo a causa de una tormenta. Si no se verá el personal que lo utilice expuesto al peligro de un golpe de corriente.
23. Los productos R&S no están protegidos contra el agua si no es que exista otra indicación, ver también punto 1. Si no se tiene en cuenta esto se arriesga el peligro de golpe de corriente para el usuario o de daños en el producto lo cual también puede llevar al peligro de personas.
24. No utilice el producto bajo condiciones en las que pueda producirse y se hayan producido líquidos de condensación en o dentro del producto como por ejemplo cuando se desplaza el producto de un lugar frío a un lugar caliente.
25. Por favor no cierre ninguna ranura u orificio del producto, ya que estas son necesarias para la ventilación e impiden que el producto se caliente demasiado. No pongan el producto encima de materiales blandos como por ejemplo sofás o alfombras o dentro de una caja cerrada, si esta no está suficientemente ventilada.
26. No ponga el producto sobre aparatos que produzcan calor, como por ejemplo radiadores o calentadores. La temperatura ambiental no debe superar la temperatura máxima especificada en la hoja de datos.
27. Baterías y acumuladores no deben de ser expuestos a temperaturas altas o al fuego. Guardar baterías y acumuladores fuera del alcance de los niños. No cortocircuitar baterías ni acumuladores. Si las baterías o los acumuladores no son cambiados con la debida atención existirá peligro de explosión (atención celulas de Litio). Cambiar las baterías o los acumuladores solamente por los del tipo R&S correspondiente (ver lista de piezas de recambio). Las baterías y acumuladores deben reutilizarse y no deben acceder a los vertederos. Las baterías y acumuladores que contienen plomo, mercurio o cadmio deben tratarse como residuos especiales. Respete en esta relación las normas nacionales de evacuación y reciclaje.
28. Por favor tengan en cuenta que en caso de un incendio pueden desprenderse del producto agentes venenosos (gases, líquidos etc.) que pueden generar daños a la salud.
29. El producto puede poseer un peso elevado. Muévelo con cuidado para evitar lesiones en la espalda u otras partes corporales.
30. No sitúe el producto encima de superficies, vehículos, estantes o mesas, que por sus características de peso o de estabilidad no sean aptas para él. Siga siempre las instrucciones de instalación del fabricante cuando instale y asegure el producto en objetos o estructuras (por ejemplo paredes y estantes).

Informaciones de seguridad

31. Las asas instaladas en los productos sirven solamente de ayuda para el manejo que solamente está previsto para personas. Por eso no está permitido utilizar las asas para la sujeción en o sobre medios de transporte como por ejemplo grúas, carretillas elevadoras de horquilla, carros etc. El usuario es responsable de que los productos sean sujetados de forma segura a los medios de transporte y de que las prescripciones de seguridad del fabricante de los medios de transporte sean tenidas en cuenta. En caso de que no se tengan en cuenta pueden causarse daños en personas y objetos.
32. Si llega a utilizar el producto dentro de un vehículo, queda en la responsabilidad absoluta del conductor que conducir el vehículo de manera segura. Asegure el producto dentro del vehículo debidamente para evitar en caso de un accidente las lesiones u otra clase de daños. No utilice nunca el producto dentro de un vehículo en movimiento si esto pudiera distraer al conductor. Siempre queda en la responsabilidad absoluta del conductor la seguridad del vehículo. El fabricante no asumirá ninguna clase de responsabilidad por accidentes o colisiones.
33. Dado el caso de que esté integrado un producto de laser en un producto R&S (por ejemplo CD/DVD-ROM) no utilice otras instalaciones o funciones que las descritas en la documentación de producto. De otra manera pondrá en peligro su salud, ya que el rayo laser puede dañar irreversiblemente sus ojos. Nunca trate de descomponer estos productos. Nunca mire dentro del rayo laser.

Certified Quality System

DIN EN ISO 9001 : 2000
DIN EN 9100 : 2003
DIN EN ISO 14001 : 1996

DQS REG. NO 001954 QM/ST UM

QUALITÄTSZERTIFIKAT

Sehr geehrter Kunde,

Sie haben sich für den Kauf eines Rohde & Schwarz-Produktes entschieden. Hiermit erhalten Sie ein nach modernsten Fertigungsmethoden hergestelltes Produkt. Es wurde nach den Regeln unseres Managementsystems entwickelt, gefertigt und geprüft.

Das Rohde & Schwarz Managementsystem ist zertifiziert nach:

DIN EN ISO 9001:2000
DIN EN 9100:2003
DIN EN ISO 14001:1996

CERTIFICATE OF QUALITY

Dear Customer,

you have decided to buy a Rohde & Schwarz product. You are thus assured of receiving a product that is manufactured using the most modern methods available. This product was developed, manufactured and tested in compliance with our quality management system standards.

The Rohde & Schwarz quality management system is certified according to:

DIN EN ISO 9001:2000
DIN EN 9100:2003
DIN EN ISO 14001:1996

CERTIFICAT DE QUALITÉ

Cher Client,

vous avez choisi d'acheter un produit Rohde & Schwarz. Vous disposez donc d'un produit fabriqué d'après les méthodes les plus avancées. Le développement, la fabrication et les tests respectent nos normes de gestion qualité.

Le système de gestion qualité de Rohde & Schwarz a été homologué conformément aux normes:

DIN EN ISO 9001:2000
DIN EN 9100:2003
DIN EN ISO 14001:1996



ROHDE & SCHWARZ



ROHDE & SCHWARZ
EC Certificate of Conformity



Certificate No.: 2003-39

This is to certify that:

Equipment type	Stock No.	Designation
SM300	1147.1498.03	Vector Signal Generator

complies with the provisions of the Directive of the Council of the European Union on the approximation of the laws of the Member States

- relating to electrical equipment for use within defined voltage limits
(73/23/EEC revised by 93/68/EEC)
- relating to electromagnetic compatibility
(89/336/EEC revised by 91/263/EEC, 92/31/EEC, 93/68/EEC)

Conformity is proven by compliance with the following standards:

EN61010-1 : 2001-12
EN55011 : 1998 + A1 : 1999, Klasse B
EN61326 : 1997 + A1 : 1998 + A2 : 2001

For the assessment of electromagnetic compatibility, the limits of radio interference for Class B equipment as well as the immunity to interference for operation in industry have been used as a basis.

Affixing the EC conformity mark as from 2003

ROHDE & SCHWARZ GmbH & Co. KG
Mühlendorfstr. 15, D-81671 München

Munich, 2003-08-21

Central Quality Management FS-QZ / Becker

Support Center Address

Technical support – where and when you need it

For quick, expert help with any Rohde & Schwarz equipment, contact one of our Customer Support Centers. A team of highly qualified engineers provides telephone support and will work with you to find a solution to your query on any aspect of the operation, programming or applications of Rohde & Schwarz equipment.

Up-to-date information and upgrades

To keep your Rohde & Schwarz equipment always up-to-date, please subscribe to an electronic newsletter at

<http://www.rohde-schwarz.com/www/response.nsf/newsletterpreselection>

or request the desired information and upgrades via email from your Customer Support Center (addresses see below).

Feedback

We want to know if we are meeting your support needs. If you have any comments please email us and let us know

CustomerSupport.Feedback@rohde-schwarz.com

Customer support center

USA & Canada

Monday to Friday (except US-state holidays)
8:00 AM – 8:00 PM Eastern Standard Time (EST)

USA: 888-test-rsa (888-837-8772) (opt 2)
From outside USA: +1 410 910 7800 (opt 2)
Fax: 410 910 7801

E-Mail: Customer.Support@rsa.rohde-schwarz.com

Rest of World

Monday to Friday (except German-state holidays)
08:00 – 17:00 Central European Time (CET)

Europe: +49 (0) 180 512 42 42
From outside Europe: +49 89 4129 13776
Fax: +49 (0) 89 41 29 637 78

E-Mail: CustomerSupport@rohde-schwarz.com

Address List

Headquarters, Plants and Subsidiaries

Headquarters

ROHDE&SCHWARZ GmbH & Co. KG
Mühlendorfstraße 15 · D-81671 München
P.O.Box 80 14 69 · D-81614 München

Phone +49 (89) 41 29-0
Fax +49 (89) 41 29-121 64
info.rs@rohde-schwarz.com

Plants

ROHDE&SCHWARZ Messgerätebau GmbH
Riedbachstraße 58 · D-87700 Memmingen
P.O.Box 16 52 · D-87686 Memmingen

Phone +49 (83 31) 1 08-0
+49 (83 31) 1 08-1124
info.rsmb@rohde-schwarz.com

ROHDE&SCHWARZ GmbH & Co. KG
Werk Teisnach
Kaikenrieder Straße 27 · D-94244 Teisnach
P.O.Box 11 49 · D-94240 Teisnach

Phone +49 (99 23) 8 50-0
Fax +49 (99 23) 8 50-174
info.rsdts@rohde-schwarz.com

ROHDE&SCHWARZ závod
Vimperk, s.r.o.
Location Spidrova 49
CZ-38501 Vimperk

Phone +420 (388) 45 21 09
Fax +420 (388) 45 21 13

ROHDE&SCHWARZ GmbH & Co. KG
Dienstleistungszentrum Köln
Graf-Zeppelin-Straße 18 · D-51147 Köln
P.O.Box 98 02 60 · D-51130 Köln

Phone +49 (22 03) 49-0
Fax +49 (22 03) 49 51-229
info.rsdcm@rohde-schwarz.com
service.rsdcm@rohde-schwarz.com

Subsidiaries

R&S BICK Mobilfunk GmbH
Fritz-Hahne-Str. 7 · D-31848 Bad Münder
P.O.Box 20 02 · D-31844 Bad Münder

Phone +49 (50 42) 9 98-0
Fax +49 (50 42) 9 98-105
info.bick@rohde-schwarz.com

ROHDE&SCHWARZ FTK GmbH
Wendenschloßstraße 168, Haus 28
D-12557 Berlin

Phone +49 (30) 658 91-122
Fax +49 (30) 655 50-221
info.ftk@rohde-schwarz.com

ROHDE&SCHWARZ SIT GmbH
Am Studio 3
D-12489 Berlin

Phone +49 (30) 658 84-0
Fax +49 (30) 658 84-183
info.sit@rohde-schwarz.com

R&S Systems GmbH
Graf-Zeppelin-Straße 18
D-51147 Köln

Phone +49 (22 03) 49-5 23 25
Fax +49 (22 03) 49-5 23 36
info.rssys@rohde-schwarz.com

GEDIS GmbH
Sophienblatt 100
D-24114 Kiel

Phone +49 (431) 600 51-0
Fax +49 (431) 600 51-11
sales@gedis-online.de

HAMEG Instruments GmbH
Industriestraße 6
D-63533 Mainhausen

Phone +49 (61 82) 800-0
Fax +49 (61 82) 800-100
info@hameg.de

Locations Worldwide

Please refer to our homepage: www.rohde-schwarz.com

- ◆ Sales Locations
- ◆ Service Locations
- ◆ National Websites

1 Introduction

This chapter	Chapter 1 describes the use of the R&S SM300, provides information on functions and supplies tips regarding storage and transportation procedures. Warranty conditions are also explained.
Further information	Chapter 2 contains an overview of R&S SM300 control elements, indicators, etc. Chapter 3 describes how to put the instrument into operation.

1.1 Applications of the R&S SM300

Uses	<p>The Signal Generator R&S SM300 with its adjustable frequency range from 9 kHz to 3 GHz is suitable for all applications for which a high-quality signal is required. The internal LF generator can be used as a modulation source and permits generation of analog modulated signals. External signals applied to the I/Q inputs permit generation of any modulated signals as are required in mobile radio, for example (modulation source, e.g. R&S AMIQ).</p> <ul style="list-style-type: none"> ▪ Generation of precise test signals for applications in lab, service, production and quality assurance ▪ Provision of digitally modulated signals in the 9 kHz to 3 GHz frequency range (e.g. with the R&S AMIQ as an external baseband signal source) ▪ Signal generation and modulation (AM, pulse) for EMC measurements of components (EMS) ▪ Functionality testing of components in production ▪ Semiautomatic measurements by pressing a button to retrieve stored settings
Performance features	<p>The Signal Generator R&S SM300 has all the performance features required to make available precise levels and frequencies.</p> <p>The key features are:</p> <ul style="list-style-type: none"> ▪ High signal quality ▪ Internal analog modulation modes: AM / FM / ϕM ▪ Pulse modulation ▪ I/Q modulator with inputs for external digital modulation signals ▪ Frequency and level sweep ▪ Remote control via USB
Operation from keypad	<p>All functions and setting parameters can be set via menus using a keypad and a rotary knob.</p> <p>Current parameters and operating states are clearly arranged on a TFT colour display.</p>
Remote control from a PC	<p>The R&S SM300 is equipped as standard with a USB interface so that it can communicate with a PC.</p> <p>All functions and parameters can be set.</p>

1.2 Supplied Accessories

Content	1 power cord Europe
	1 country specific power cord (if different from Europe)
	1 manual German/English
	1 USB cable
	1 CD (Content: operating manual German/English, data sheet German/English PC software R&S SM300-K1, Acrobat Reader™)

1.3 Warranty

ATTENTION



Equipment returned or sent in for repair must be packed in the original packing or in packing with electrostatic and mechanical protection.

Warranty conditions

The General Terms and Conditions of Rohde & Schwarz shall apply.

Returning a defective R&S SM300

You will find the addresses of your nearest R&S representative and of the support center at the front of the manual.

Indicating claims under the warranty

We would also ask you to state clearly if you are making a claim for repairs under warranty, preferably by including your delivery note. Repair requests that do not explicitly refer to the warranty will, in the first instance, incur charges.

If your warranty has expired, we will, of course, repair your R&S SM300 in accordance with our general installation and service conditions.

2 Control Elements

2.1 Front View

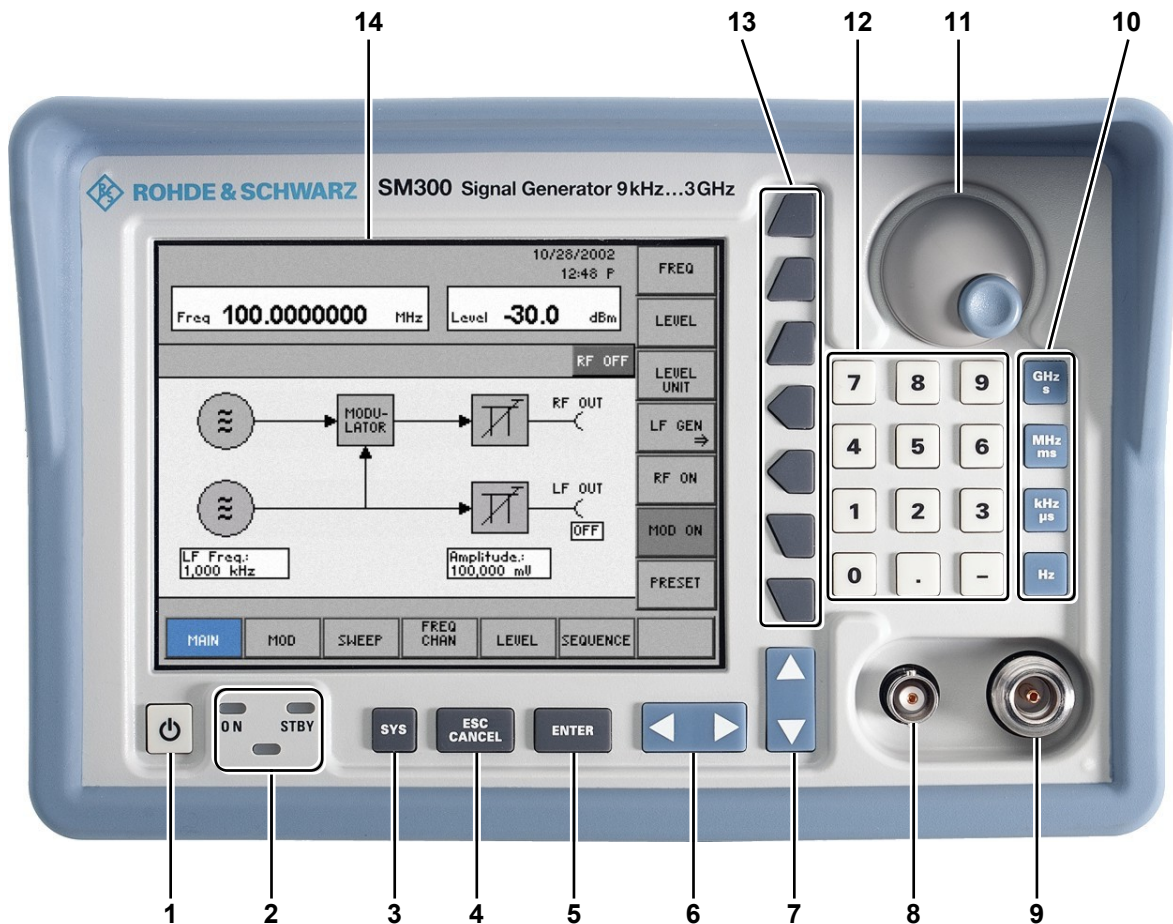

- | | | | |
|---|----------------------|----|-------------------------------------|
| 1 | ON/STANDBY switch | 8 | LF output connector (BNC connector) |
| 2 | ON/STANDBY indicator | 9 | RF output connector (N connector) |
| 3 | SYS key | 10 | Unit keys |
| 4 | ESC/CANCEL key | 11 | Rotary knob |
| 5 | ENTER key | 12 | Numerical keys |
| 6 | Cursor keys ◀ / ▶ | 13 | Function keys |
| 7 | Cursor keys ▼ / ▲ | 14 | Screen |

2.2 Rear View

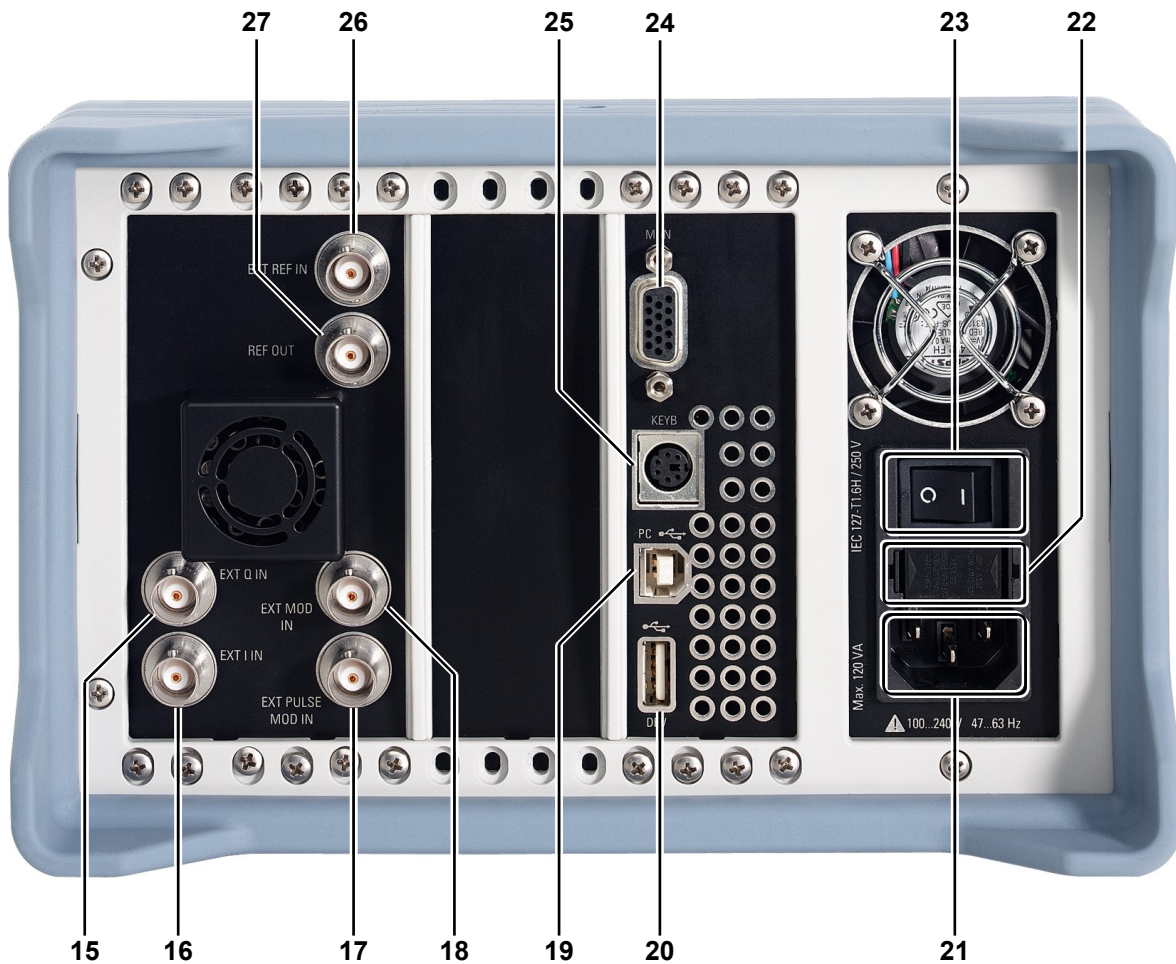

- | | | | |
|-----------|---|-----------|---|
| 15 | Input for external Q signal | 21 | AC supply connector |
| 16 | Input for external I signal | 22 | AC line fuses |
| 17 | Input for external pulse or modulation signal | 23 | AC line switch |
| 18 | Input for external modulation signal | 24 | Connector for external monitor |
| 19 | Connector for external USB host | 25 | Connector for external keyboard |
| 20 | Connector for external USB device | 26 | Input for external reference (10 MHz, 5 MHz, 2 MHz) |
| | | 27 | Output for internal/external reference (10 MHz) |

3 Putting the R&S SM300 into Operation

This chapter

Chapter 3 describes how to put the R&S SM300 into operation.

Further information

Chapter 2 contains an overview of the R&S SM300's control elements, indicators, etc.

Chapter 4, "Getting started", takes you step-by-step through a number of simple measurements.

Chapter 8 is an in-depth description of the instrument's interfaces.

ATTENTION

Before putting the R&S SM300 into operation, make the following checks:

- Ensure that the ventilation holes are free of obstructions.
- Ensure that there are no unsuitable signal voltages connected to the input.
- The R&S SM300's outputs may not be overloaded and correct polarity must be ensured.

The instrument may be damaged if the above checks are not performed.

3.1 Unpacking the R&S SM300

Recommended procedure

When you unpack the R&S SM300, proceed as follows:

1. Remove the R&S SM300 from its packaging and check that the delivery is complete using the accessory list (↗ 1-36).
2. Carefully check the R&S SM300 for any damage.
3. If there is damage, immediately contact the carrier who delivered the instrument. Under these circumstances, it is essential to keep the box in which the R&S SM300 was transported and the packaging material.

3.2 Setting up the Instrument

CAUTION

There is a risk of injury from sharp edges and becoming wedged between the setting lever and the handle.

Always be careful not to injure your fingers when installing the instrument and adjusting its handles.

Setup instructions

The R&S SM300 must be assembled on a firm, level surface only. The instrument has a carrying handle which is also used for various setup options. This handle can be moved into any position, depending on the particular field of application.

Setting the handle

1. Place the thumb and two fingers around the side-mounted setting lever and loosen it with a turning action.



2. Slide the handle lengthwise while twisting it radially in steps of about 12°.

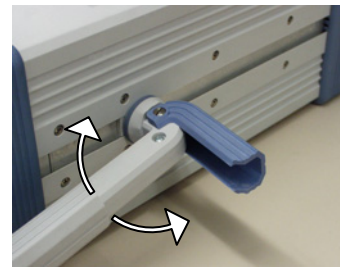
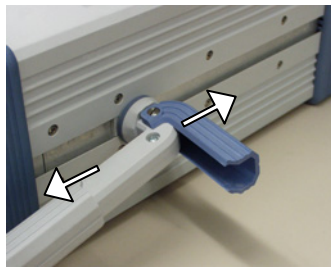

3. Close the setting lever by pressing on the outer surface.
CAUTION: There is a risk of injury from sharp edges and becoming wedged between the setting lever and the handle.



4. Remove the protective film from the screen glass if necessary.
ATTENTION: Use no pointed or sharp objects.



3.3 Connecting the R&S SM300 to the AC Line

WARNING

Danger of electric shock!

The R&S SM300 meets the requirements for Safety Class I to DIN EN 61010-1/IEC 61010-1, e.g. all metal parts that can be touched or accessed without removing the enclosure are connected to the protective ground of the power supply network.

When connecting the instrument to the AC power supply, always use a power cable and a socket with earthing contact.

Automatic AC line voltage detection

When the R&S SM300 is connected to the AC line, it automatically sets itself to the correct voltage (range: AC voltage 100 V to 240 V, AC frequency 50 Hz to 60 Hz). There is no need to set the voltage manually or change the fuse.

Connecting the AC line

1. Use the supplied power cord to connect the R&S SM300 to the AC line.
The power supply connector [21] is at the rear of the instrument.
2. Connect the power cord to the AC line.

3.4 Switching On the R&S SM300

NOTE	The AC line is still connected to the R&S SM300 when the instrument is in the standby mode.
AC line switch on the rear panel	The R&S SM300 is connected to the AC line via power supply connector [21]. AC line switch [23] which isolates the R&S SM300 from the AC line is located next to the power supply connector.
ON/STANDBY switch on the front panel	<p>ON operating state After switching on the R&S SM300 by means of the AC line switch [23] at the rear panel, it is in standby mode and the yellow LED [2] comes on. If you press the ON/STANDBY switch [1], the instrument is switched on and the green LED [2] comes on.</p> <p>STANDBY operating state To switch the R&S SM300 from the operating mode to standby mode, press the ON/STANDBY switch [1] for approx. 2 seconds. After switching off the ON/STANDBY switch [1] the yellow LED [2] comes on.</p>
Switching on the R&S SM300	<ol style="list-style-type: none"> 1. Press the AC line switch [23] on the rear panel in the I position. 2. Press the ON/STANDBY switch [1] on the front panel. <p>The green ON LED [2] should come on.</p>

3.5 Function Test

ATTENTION



The R&S SM300 does not contain any parts the operator can repair. Only properly qualified technicians are allowed to repair the instrument. When performing service procedures, follow the requirements of VDE 0701.

Function test	After the R&S SM300 has been switched on (↗ 3-42), the green LED ON [2] on the instrument's front panel comes on. During booting, the "R&S SmartInstruments" symbol appears on a blue screen background [14]. Booting the R&S SM300 is completed when the frequency and level display (↗ 5-51) appear.
In error case	If the measurement mask does not appear and the red or the red or green LED flash alternately, switch the R&S SM300 off and on. In case the error continues, return the instrument to our service center for checking. When the red and green LEDs flash alternately [2] an internal error has been recognized. Return the instrument to our service center for checking.

3.6 EMC

EMC requirements

The R&S SM300 meets the EMC Directive 89/336/EEC (applied standards EN 55011 Class B and EN 61326).

To prevent EMI, the R&S SM300 may only be operated with its enclosure closed. Only appropriately shielded signal and control cables may be used. External units, such as keyboard, printer or monitor, that are to be connected to the R&S SM300 must comply with EMC directives.

3.7 Connecting an External Keyboard

ATTENTION



Only connect the keyboard when the R&S SM300 is off or in the STANDBY mode, otherwise malfunctions may occur at a later date.

Use

You can connect an external PC keyboard via the 6-pin PS/2 KEYB connector [25] on the R&S SM300's rear panel. The keyboard makes it easier to enter file names. The keyboard allows data entry as well as operation of the R&S SM300.

The keyboard is detected automatically when it is connected.

Key assignment for operating the R&S SM300

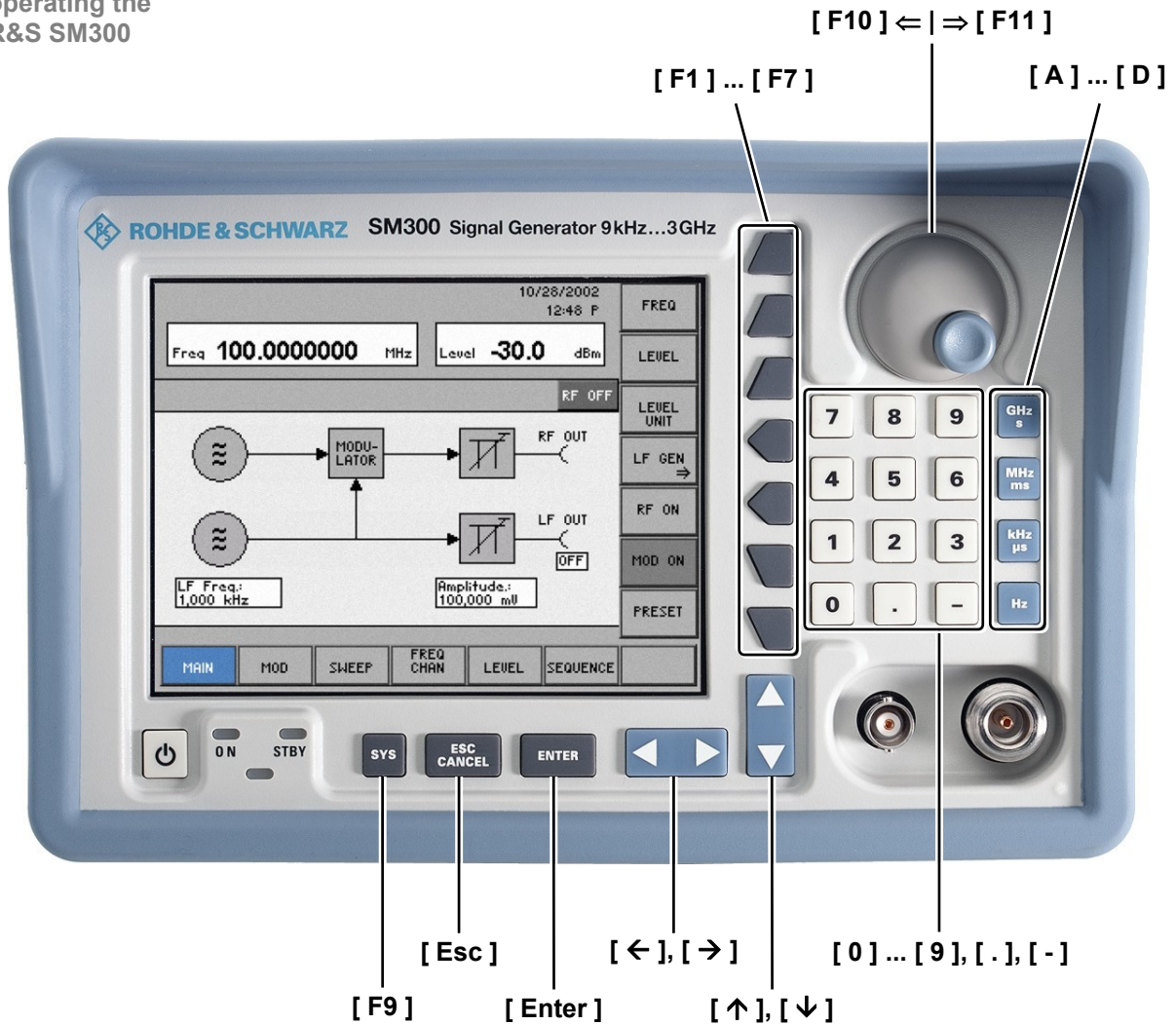

3.8 Connecting a USB Stick

ATTENTION



To ensure that the USB stick is detected by the R&S SM300, the stick must be formatted in the FAT32 file system.

Use

You can connect an external USB stick to the USB device interface [20] at the rear of the R&S SM300. The USB stick is an extension of the internal memory. You can use it to save or load instrument settings, to print into a file on the USB stick or to transfer trace data to a PC.

4 Getting Started

This chapter	Chapter 4 uses a number of simple settings to illustrate how to operate the R&S SM300. For the following example, the initial setting for instrument is the default setting (factory). This is set in the menu PRESET (↗ 6-165). The full default setup is described in chapter 6.
Further information	Chapter 5 contains an in-depth explanation of the basic operating steps, for example selecting menus and setting parameters. The layout of the screen and the information displayed on the screen are also described. Chapter 6 describes all the R&S SM300's menus and the associated functions in detail.

4.1 Level and Frequency Setting

4.1.1 Task

Initial position	Generating the level and frequency of a signal is one of the most common tasks a signal generator is used to make. Often the PRESET settings (factory) are chosen as a suitable initial setup (↗ 6-165).
Solution	Important functions for the provision of the generator signal are the input of the HF signal level and the HF signal frequencies.

4.1.2 Setting Steps

Introduction

In this example, a signal with a frequency of 200 MHz and a level of -15 dBm is applied to the RF output [9]. The parameters are set manually.

Setting steps

Perform the following steps:

1. Reset the R&S SM300

- Select **MAIN** in lower menu line using the cursor keys 
- Press the **PRESET** key. The following message is displayed:



- Respond to query with **ENTER**.

2. Enter the RF signal frequency

- Remain in the **MAIN** menu.
- Press function key **FREQ**.
- Enter the value **2 0 0** using the keypad. Terminate with the **MHz** unit key.

3. Enter the RF signal level

- Remain in the **MAIN** menu.
- Press function key **LEVEL**.
- Enter the value **- 1 5** using the key pad. Terminate the entry with **ENTER**.

4. Switch on the output

- Remain in the **MAIN** menu.
- Press function key **RF ON**.

5 Manual Operating Concept

This chapter Chapter 5 contains an overview of the R&S SM300's basic manual operating concept. This includes a description of the keypad, the screen layout, menu operation and how to set parameters. There is an overview of the menus and functions at the end of this chapter.

Further information Chapter 6 contains an in-depth description of the menu functions.
Chapter 4 contains a brief introduction that takes you step-by-step through some simple settings.
In Chapter 7 you can find notes how the R&S SM300 is remote-controlled.

5.1 Making Entries from the Keypad

Introduction The R&S SM300 is operated using menus in conjunction with a keypad and a rotary knob. The keypad comprises the following sections:

- Numerical keys [12]
- Unit keys [9]
- Cursor keys [6, 7]
- Function keys [13]
- Action keys [4, 5]
- SYS key [3]

5.1.1 Numerical Keys

Function The numerical keys are used to enter numerical parameters.

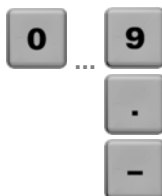

- Inserts one of the digits “0” to “9” at the cursor position.
- Inserts a decimal point “.” at the cursor position.
- Inserts a minus sign “-” at the cursor position.

5.1.2 Unit Keys

Function The unit keys are used to assign the appropriate unit to the number that has been entered, simultaneously terminating the entry.



- Assigns **GHz** when a **frequency setting** is being made
- Assigns **s** when a **time setting** is being made



- Assigns **MHz** when a **frequency setting** is being made
- Assigns **ms** when a **time setting** is being made



- Assigns **kHz** when a **frequency setting** is being made
- Assigns **μs** when a **time setting** is being made



- Assigns **Hz** when a **frequency setting** is being made

NOTE

In the case of all other entries, the unit keys assume the same function as the ENTER key (↗ 5-50).

5.1.3 Rotary Knob

Function

As well as the numerical keys and the cursor keys, the rotary knob is also used to set parameters.



The rotary knob has several functions:

- **Incrementing** (turn clockwise) or **decrementing** (turn counter-clockwise) numerical instrument parameters using a specified step size.

5.1.4 Cursor Keys

Function

As well as the numerical keys and the rotary knob, the cursor keys are also used for entering parameters and to navigate through the menus.



The cursor keys have the following functions:

- **Navigating** through menus and selection fields
- The ◀ or ▶ cursor keys **move** the cursor to the position you want within the numerical editing line.
- The ▼ or ▲ cursor keys **increment** or **decrement** numerical parameter entries.

5.1.5 Function Keys

Function

In the function area, various instrument functions are displayed depending on which menu has been selected.

The displayed instrument functions are assigned to the seven function keys down the right side of the screen. This means that each function key can have a variety of functions (↗ 5-53).



When a function key is pressed, various responses can be elicited:

- Immediate activation of a function or toggling between settings
- Entry of a value or selection of a setting/function
- Confirmation of a new setting and opening of a new menu item
- Branching to a submenu

5.1.6 Action Keys

Function

The action keys are for terminating menu-guided settings.



- This key is for **closing the entry field** or selection field after data has been entered. The **new value** is set on the R&S SM300.

NOTE: Pressing a unit key will also terminate the entry of setting data.



- This key is for **closing the entry field** or selection field, but the data that has been entered is not saved - in other words the **old value** is retained.

5.1.7 SYS Key

Function

The SYS key is for opening and quitting the SYS menu (system and service functions).



- When you press the SYS key [3], the measuring menu is blanked out and replaced by the SYS menu. Other functions are assigned to the function keys [13] and the measurement diagram is replaced by the system parameters (↗ 6-163).
- By repeatedly pressing the SYS key [3], you can quit the SYS menu and accept the new settings.

5.2 Screen Display

Introduction

The screen [14] provides on-going information about events and the parameters associated with the selected measurement functions. The display mode for the measurement results, the lettering of the function keys and the type of menu all depend on the current settings.

Screen layout

The screen is divided into three areas:

- I Diagram area
- II Menu area
- III Function area

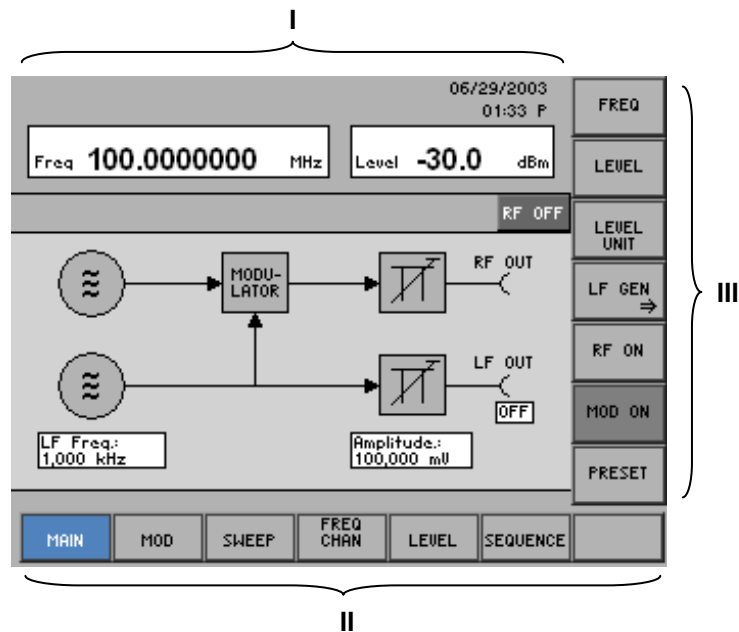

5.2.1 Display Window

Introduction

The display window of the R&S SM300 varies depending on the selected menu. When the MAIN menu is selected, a simplified block diagram of the generator is displayed in the parameter area. In all other menus, the currently set values are displayed in the form of a list. Irrespective of the selected menu, the frequency and level of the RF signal as well as the status information are displayed in the upper section of the display.

Display window

The display window contains:

- Frequency (a) and level (c) display
- Date (b)
- Status line (d)
- Field for current parameters (g)
- Selection fields and entry fields that come up on the screen (f)
- Error messages that come up on the screen (e)

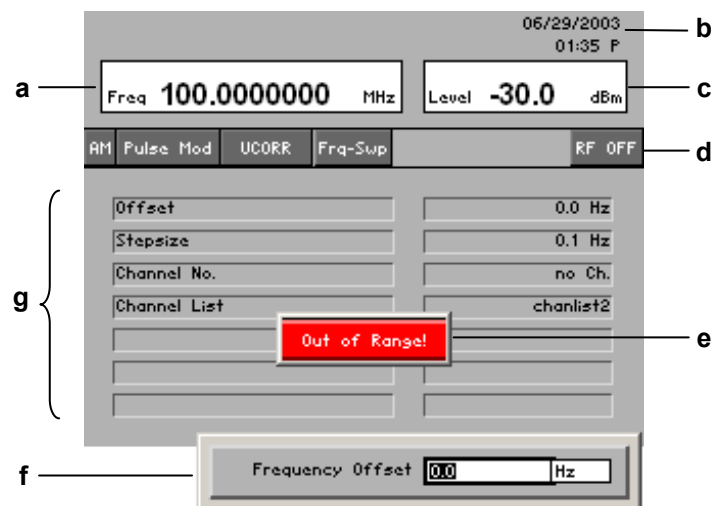

Status line

The status line shows specific settings in the instrument:

- | | |
|--|---|
| AM (FM, ϕM, IQ) | - selected modulation mode |
| Pulse Mod | - selected modulation mode |
| UCORR | - selected user-defined correction list |
| Frq-Swp (Lev, LF) | - selected Sweep mode |
| RF ON (OFF) | - current status of RF output |

Current Parameter field

In the parameter field, the parameters currently set in the specific menu, e. g. the FREQ CHAN menu, are displayed:

- | | |
|----------------------|---|
| Offset: | - RF frequency offset |
| Stepsize: | - step size for frequency entry using the rotary knob |
| Channel No.: | - channel number in the channel list |
| Channel List: | - channel list |

5.2.2 Menu Area

Menu display

Menus for setting the setting parameters and the setting functions are displayed in the menu area. The selected menu is highlighted, e.g. MAIN menu.



5.2.3 Function Area

Displaying the current assignment for the function keys

When a menu is selected, the associated instrument functions are displayed in the function area.

The displayed instrument functions are assigned to the seven function keys down the right-hand side of the screen. If a key in the function area does not have any lettering, the key has not been assigned a function in the menu in question. If a key has lettering, but not in full brightness, the key has temporarily (current setting) not been assigned a function.

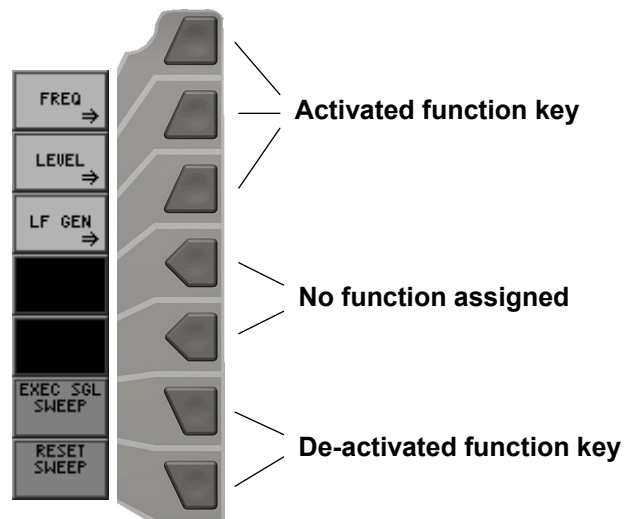

5.3 Calling and Changing Menus

Introduction

Operating the R&S SM300 is menu-guided. All the menus used to set the measurement parameters and measurement functions are displayed in the menu area. The instrument functions associated with any menu you select are displayed in the function area.

Pressing a function key has one of the following effects:

- Direct execution of an instrument function
- Toggling of a setting
- Opening of entry or selection windows
- Opening of submenus

The ◀ or ▶ cursor keys [6] are used for menu navigation.

Calling or changing menus

1. Select a **menu**, e.g. MOD, with the ◀ or ▶ [6] **cursor keys**.

The menu name is highlighted and the appropriate function is assigned to the function keys [13].

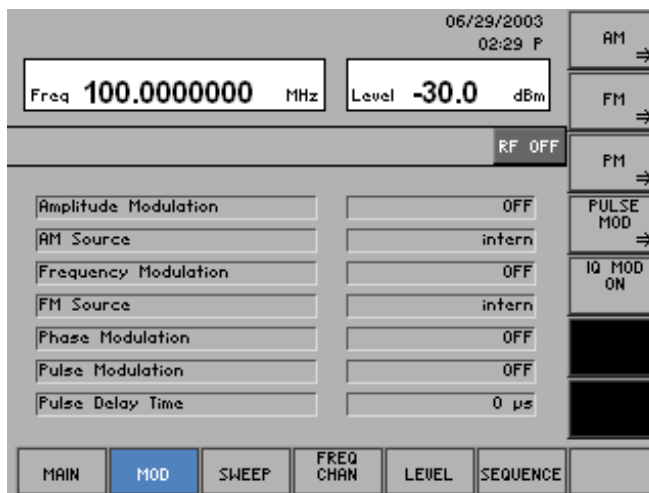

NOTE

A double arrow ⇒ pointing to a function key, e.g. AM ⇒, tells you that pressing this key will call a submenu.

Calling/quitting submenus

2. Press the  function key in the  menu.

The AM submenu opens and the new functions are assigned to the function keys [13].

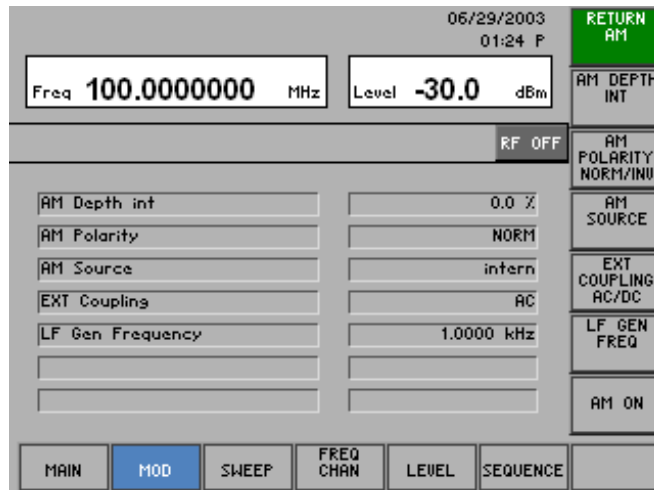

3. Press the  function key in the  submenu.

The submenu is closed and the previous functions remain assigned to the function keys [13].

NOTE

You can also exit the submenu by using the cursor keys ◀ oder ▶ [6].

5.4 Setting Parameters

There is a choice of methods

Parameters can be set in a number of ways:

- Direct selection of an instrument function (function key)
- Toggling of a setting
- Selecting settings from selection fields
- Entering numerical parameters in entry fields

The numerical keys [12], the unit keys [9], the rotary knob [11], the cursor keys [6, 7] and the action keys [4, 5] can all be used to select and enter instrument parameters.



5.4.1 Direct Selection of Instrument Functions

Introduction

When you select a menu, various instrument functions are displayed in the function area. Some instrument functions can be set directly by pressing a function key.

The function key you select is highlighted.

e.g.:
Performing a single sweep
(↗ 6-104)

1. Select the **menu**  with the ◀ or ▶ [6] **cursor keys**.
2. Setting the frequency sweep mode „Single“ (↗ 6-104).
3. Press the  **function key** in the  **menu**.

A single sweep is performed. This procedure can be repeated as often as desired.



5.4.2 Toggling a Setting

Introduction



When a menu is selected, a number of instrument functions will be displayed in the function area. Some instrument functions can be switched on or off by a stroke of the function key (toggling).

The function key is highlighted when the instrument function is active.

e.g.:
Switching the RF output on/off
(↗ 6-74)

1. Select the  menu with the ◀ or ▶ cursor key [6].
2. Press the  **function key** in the  **menu**.

The function key is **highlighted** and the RF output is active. The output signal with the currently set parameters is present.

3. To deactivate the RF output, press the  **function key** in the  **menu**.

The function key is no longer highlighted and the output parameters are no longer present at the RF output.

5.4.3 Selecting Settings

Introduction

When you select a menu, a number of instrument functions are displayed in the function area. If certain function keys are then pressed, a selection field is displayed in the diagram area. You can then choose and activate any of the settings offered for selection.

The function key you select is highlighted.

e.g.:
Setting the level
display range
(➤ 6-74)

1. Select the **MAIN** menu with the ◀ or ▶ cursor key [6].

2. Press the **LEVEL UNIT** function key in the **MAIN** menu.

A selection field containing the available settings is displayed. The default setting is „dBm“.

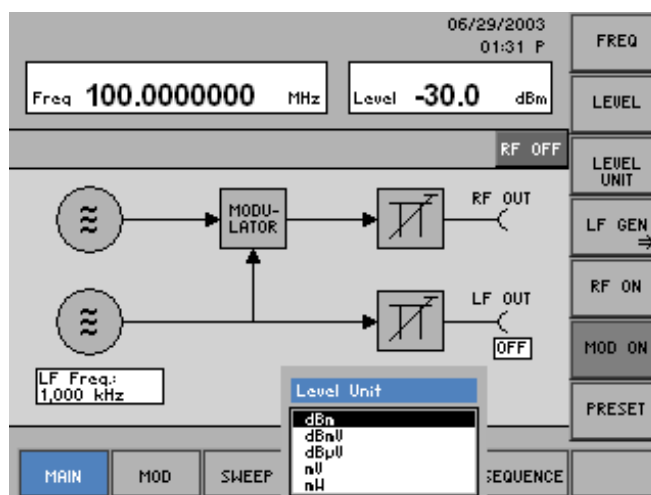

3. Select a unit with **rotary knob** [11].

4. Press the **ENTER** key [5] to close the selection field.

The new setting is saved.

If you want to keep the old setting, close the entry field with the **ESC/CANCEL** key [4].

NOTE

If there are more than five options, a scroll bar is displayed on the right next to the selection field. At any one time, only five options are displayed on the screen.

5.4.4 Entering Numerical Parameters

Introduction

When you select a menu, a number of instrument functions will be displayed in the function area. If you press certain function keys, an entry field will be displayed in the diagram area.

The function key you select is highlighted.

There are two ways of entering numerical parameters:

- **Entry** of a number with the **numerical keys**
- **Entry** of a number with the **cursor keys** and **rotary knob**

5.4.4.1 Entry with the Numerical Keys

e.g.:
Setting the
RF frequency
(↗ 6-74)

1. Select the **MAIN** menu with the ◀ or ▶ cursor key [6].

2. Press the **FREQ** function key in the **MAIN** menu.

An entry field containing the current setting is displayed.

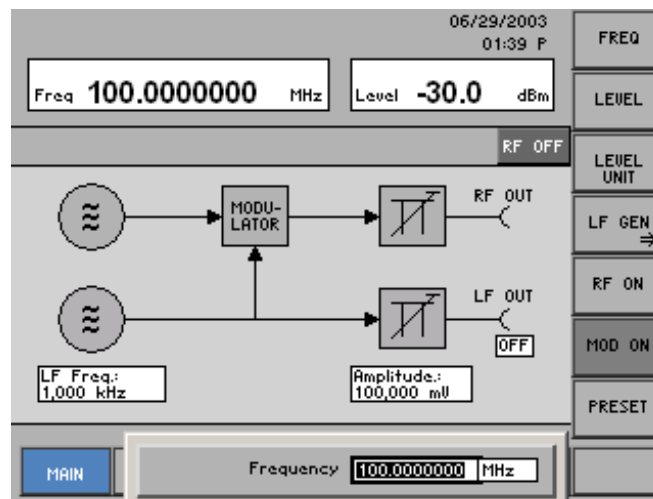

Entering
a new value

3. Overwrite the old value, e.g. 1.5 GHz, with the **numerical keys** [12].



NOTE: If a numerical key is pressed after the entry field is brought up on the screen, the old value will be erased. However, a complete new value must now be entered using the numerical keys.

Terminating entries

4a. Press a **unit key** [9], e.g. **GHz**, to terminate the entry.



The R&S SM300 sets the value that has been set numerically using the **new unit**. The entry window is closed.

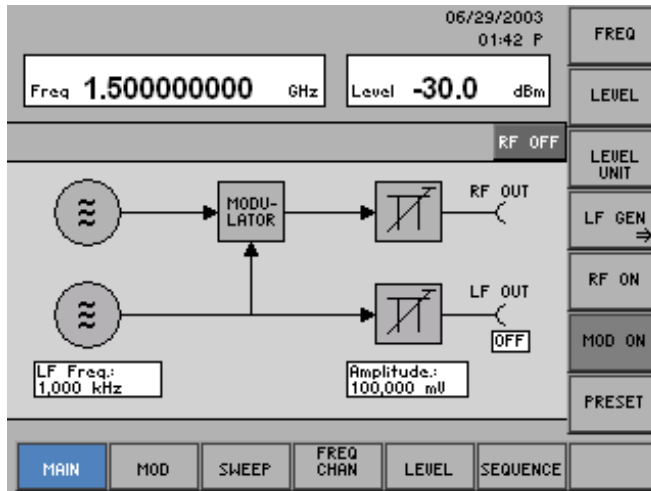

4b. Press the **ENTER** key [5] to terminate the entry.



The R&S SM300 sets the value that has been set numerically, but with the **old unit**. The entry window is closed.

NOTE: If a parameter is unitless or always has the same unit, you can terminate the entry with the ENTER key or one of the unit keys.

4c. Press the **ESC/CANCEL** key [4] to abort the entry.



The **old value** is retained. The entry window is closed.

Invalid parameter entry

If an invalid parameter is entered, the new value is rejected by the R&S SM300 and an error message is issued in the status line for 3 s:

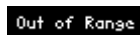

NOTE





When numbers are displayed, only the digit sequences 1 to 999 appear before the decimal point. In other words, if the digit sequence <5000> and the unit <kHz> are entered, <5 MHz> appears in the display. Trailing zeros will be eliminated in the display area.

5.4.4.2 Entry using the Cursor Keys and the Rotary Knob

NOTE

When you enter the center frequency, you can specify the step width of the rotary knob (↷ 6-119, 6-136). In this case, the value is incremented or decremented in accordance with the specified step width, with the cursor always moving to the highest value, irrespective of its earlier position.

e.g.:
Setting the
LF frequency
(↷ 6-77)

1. Select the  menu with the ◀ or ▶ cursor key [6].
2. Press the  function key in the  menu.
3. Press the  function key in the  menu.

An entry field containing the current setting is displayed.

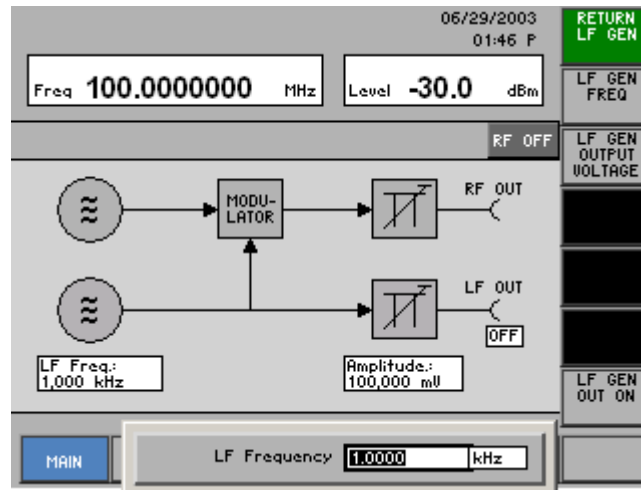

Entering
a new value,
e.g. 1.5

4. Using the **cursor keys** ◀ and ▶ [6], position the cursor on a decimal place in the entry field.



- 5a. Press the ▼ or ▲ **cursor key** [7] until you obtain the value you want.

Pressing the ▲ cursor key once increments the value by one; pressing the ▼ cursor key once decrements the value by one.



- 5b. Turn the **rotary knob** [11] until you obtain the value you want.

Turning clockwise increases the value; turning counter-clockwise reduces the value.



NOTE: In both cases, there are carries associated with incrementation or decrementation. In other words, if a 9 digit is incremented or a 0 digit decremented, a carry is added to or subtracted from next highest digit.

Terminating entries

- 6a. Press a **unit key** [9], e. g. **kHz**, to terminate the entry.



The R&S SM300 sets the value that has been entered using the **new unit**. The entry window is closed.

- 6b. Press the **ENTER key** [5] to terminate the entry.

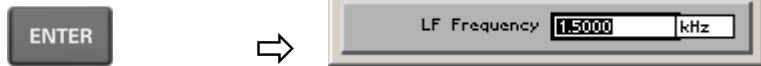

The R&S SM300 sets the value that has been set numerically but with the **old unit**. The entry window is closed.

NOTE: If a parameter is unitless or always has the same unit, you can terminate the entry with the ENTER key or one of the unit keys.

- 6c. Press the **ESC/CANCEL key** [4] to abort the entry.



The **old value** is retained. The entry window is closed.

Invalid parameter entry

If the limit value is reached, the numeric value in the entry window remains the same and is neither increased nor decreased. No error message is issued.

NOTE

When numbers are displayed, only the digit sequences 1 to 999 appear before the decimal point. In other words, if the digit sequence <5000> and the unit <kHz> are entered, <5 MHz> appears in the display. Trailing zeros will be eliminated in the display area.

5.5 Overview of all Menus and Functions

5.5.1 Signal Generator

5.5.1.1 MAIN Menu

Function key assignment

FREQ	Entering the signal generator output frequency	(↗ 6-74)
LEVEL	Entering the signal generator output level	(↗ 6-74)
LEVEL UNIT	Selecting the unit for the output level	(↗ 6-74)
LF GEN →	Open submenu: Configuring the LF signal	
RETURN LF GEN	Quitting the submenu	
LF GEN FREQ	Entering the LF generator output frequency	(↗ 6-77)
LF GEN OUTPUT VOLTAGE	Entering the LF generator output level	(↗ 6-77)
LF GEN OUT ON	Switching the output signal of the LF generator on/off	(↗ 6-77)
RF ON	Switching the generator output signal on/off	(↗ 6-74)
MOD ON	Switching the modulation on/off	(↗ 6-78)
PRESET	Loading default setting of R&S SM300	(↗ 6-79)

5.5.1.2 MOD Menu

Function key assignment

AM ⇒	Open submenu: Setting the amplitude modulation	
RETURN AM	Quitting the submenu	
AM DEPTH INT	Entering the modulation depth	(↗ 6-82)
AM POLARITY NORM/INV	Setting the polarity of the modulation voltage	(↗ 6-83)
AM SOURCE	Selecting the modulation source	(↗ 6-84)
EXT COUPLING AC/DC	Setting coupling of external LF generator	(↗ 6-84)
LF GEN FREQ	Entering the frequency of the internal LF generator	(↗ 6-85)
AM ON	Switching modulation on/off	(↗ 6-85)

FM ⇒	Open submenu: Setting the frequency modulation	
RETURN AM	Quitting the submenu	
FM DEVIATION INT	Entering the frequency deviation	(↗ 6-87)
FM POLARITY NORM/INV	Setting the polarity of the modulation voltage	(↗ 6-88)
FM SOURCE	Selecting the modulation source	(↗ 6-89)
EXT COUPLING AC/DC	Setting the coupling of the external LF generator	(↗ 6-89)
LF GEN FREQ	Entering the frequency of the internal LF generator	(↗ 6-90)
FM ON	Switching the modulation on/off	(↗ 6-90)

PM ⇒	Open submenu: Setting the phase modulation	
RETURN FM	Quitting the submenu	
PM Deviation	Entering the ϕ M deviation	(↗ 6-92)
LF GEN FREQ	Entering the frequency of the internal LF generator	(↗ 6-93)
PM ON	Switching the modulation on/off	(↗ 6-93)

PULSE MOD ⇒	Open submenu: Setting the pulse modulation	
RETURN PULSE MOD	Quitting the submenu	
PULSE OFF TIME	Entering the pulse off time	(↗ 6-95)
PULSE ON TIME	Entering the pulse on time	(↗ 6-95)
PULSE DELAY TIME	Entering the pulse delay time	(↗ 6-96)
PULSE SOURCE	Selecting the modulation source	(↗ 6-96)
PULSE POLARITY	Setting the pulse polarity	(↗ 6-97)
PULSE MOD ON	Switching the modulation on/off	(↗ 6-97)
IQ MOD ON	Switching I/Q modulation on/off	(↗ 6-98)

5.5.1.3 SWEEP Menu

Function key assignment

FREQ ⇒	Open submenu: Configuring the frequency sweep	
RETURN FREQ	Quitting the submenu	
START	Entering a start frequency	(↗ 6-101)
STOP	Entering a stop frequency	(↗ 6-101)
STEP SIZE	Entering a step size	(↗ 6-102)
DWELL	Entering a dwell time per step	(↗ 6-102)
SPACING LIN/LOG	Setting sweep spacing	(↗ 6-102)
FREQ SWEEP MODE	Setting/starting the sweep mode	(↗ 6-104)
LEVEL ⇒	Open submenu: Configuring the level sweep	
RETURN LEVEL	Quitting the submenu	
START	Entering a start level	(↗ 6-107)
STOP	Entering a stop level	(↗ 6-107)
STEP SIZE	Entering a step size	(↗ 6-108)
DWELL	Entering a dwell time per step	(↗ 6-108)
LEVEL SWEEP MODE	Setting/starting the sweep mode	(↗ 6-109)
LF GEN ⇒	Open submenu: Configuring the frequency sweep of the internal LF generator	
RETURN LF GEN	Quitting the submenu	
START	Entering a start frequency	(↗ 6-112)
STOP	Entering a stop frequency	(↗ 6-112)
STEP SIZE	Entering a step size	(↗ 6-113)
DWELL	Entering a dwell time per step	(↗ 6-113)
Spacing: LIN/LOG	Setting sweep spacing	(↗ 6-113)
LF FREQ SWEEP MODE	Setting/starting the sweep mode	(↗ 6-115)
EXEC SGL SWEEP	Starting a single sweep	(↗ 6-104, 6-109, 6-115)
RESET SWEEP	Resetting an ongoing sweep	(↗ 6-104, 6-109, 6-115)

5.5.1.4 **FREQ CHAN Menu**

Function key assignment

FREQ OFFSET	Entering the signal generator frequency offset	(↗ 6-118)
FREQ STEPSIZE	Setting the step size for frequency entry with the rotary knob	(↗ 6-119)
CHANNEL NO.	Calling the channel number from the channel list	(↗ 6-132)
CH LIST →	Open submenu: Entering channel lists	
RETURN CH LIST	Quitting the submenu	
SELECT LIST	Selecting a channel list	(↗ 6-122, 6-132)
NEW LIST	Open list menu: Creating a new channel list	(↗ 6-122)
VIEW / EDIT LIST	Open list menu: Viewing/editing a channel list	(↗ 6-122)
SAVE & RETURN	Saving a setting and quitting the list menu	
INSERT	Open entry menu: Inserting a list entry	(↗ 6-124)
EDIT	Open entry menu: Editing a list entry	(↗ 6-124)
SAVE & RETURN	Saving a setting and quitting the entry menu	
EDIT START CH.	Entering a number for the first channel	
EDIT END CH.	Entering a number for the last channel	
EDIT START FREQ	Entering a frequency value for the first channel	
EDIT SPACE FREQ	Entering a space frequency between the channels	
DELETE	Open line delete menu: Deleting a list entry	(↗ 6-129)
SAVE & RETURN	Saving a setting and quitting the line delete menu	
EDIT POSITION	Entering the line number of the list entry to be deleted	
EDIT COUNT	Entering the number of list entries to be deleted	
DELETE LIST	Deleting a channel list	(↗ 6-160)
EXCLUDE FROM RCL ON	Holding the current frequency setting	(↗ 6-133)

5.5.1.5 LEVEL Menu

Function key assignment

LEVEL OFFSET	Entering the signal generator level offset	(↗ 6-135)
STEPSIZE	Setting the step size for level entry with the rotary knob	(↗ 6-136)
EMF	Converting the level/voltage display	(↗ 6-136)
UCOR →	Open submenu: Switching manual level correction on, entering correction lists	
RETURN UCOR	Quitting the submenu	
SELECT LIST	Selecting a correction list	(↗ 6-138, 6-147)
NEW LIST	Open list menu: Creating a new correction list	(↗ 6-138)
VIEW / EDIT LIST	Open list menu: Viewing/editing a correction list	(↗ 6-138)
SAVE & RETURN	Saving a setting and quitting the list menu	
INSERT	Open entry menu: Inserting a list entry	(↗ 6-140)
EDIT	Open entry menu: Editing a list entry	(↗ 6-140)
SAVE & RETURN	Saving a setting and quitting the entry menu	
EDIT FREQ.	Entering a frequency value for level correction	
EDIT LEVEL CORR.	Entering a level value for level correction	
DELETE	Open line delete menu: Deleting a list entry	(↗ 6-144)
SAVE & RETURN	Saving a setting and quitting the line delete menu	
EDIT POSITION	Entering the line number of the list entry to be deleted	
EDIT COUNT	Entering the number of list entries to be deleted	
DELETE LIST	Deleting a correction list	(↗ 6-146)
USER CORR ON	Switching a correction list on/off	(↗ 6-147)

5.5.1.6 SEQUENCE Menu



Function key assignment

SEQUENCE →	Open submenu: Creating a sequence	
RETURN SEQUENCE	Quitting the submenu	
SELECT SEQUENCE	Selecting a sequence list	(↗ 6-152), (↗ 6-161)
NEW SEQUENCE	Open list menu: Creating a new sequence list	(↗ 6-152)
VIEW / EDIT SEQUENCE	Open list menu: Viewing/editing a sequence list	(↗ 6-152)
SAVE & RETURN	Saving a setting and quitting the list menu	
INSERT	Open entry menu: Inserting a list entry	(↗ 6-154)
EDIT	Open entry menu: Editing a list entry	(↗ 6-154)
SAVE & RETURN	Saving a setting and quitting the entry menu	
EDIT INDEX	Entering the index (line number) of the list entry	
SELECT CONFIG NR.	Inserting an instrument setting	
EDIT DWELL	Entering the dwell time of the setting	
DELETE	Open line delete menu: Deleting a list entry	(↗ 6-158)
SAVE & RETURN	Saving a setting and quitting the line delete menu	
EDIT POSITION	Entering the line number of the list entry to be deleted	
SELECT CONFIG NR.	Entering the number of list entries to be deleted	
DELETE SEQUENCE	Deleting a sequence list	(↗ 6-160)
SAVE SETTING	Saving instrument settings	(↗ 6-149)
RECALL SETTING	Loading instrument settings	(↗ 6-149)
SEQUENCE MODE	Setting the sequence mode	(↗ 6-161)
EXEC SINGLE SEQUENCE	Starting a single sequence	(↗ 6-161)
RESET SEQUENCE	Resetting an ongoing sequence	(↗ 6-161)

5.5.2 SYSTEM Functions

5.5.2.1 PRESET Menu

Function key assignment

	Calls an instrument default setting	(↗ 6-166)
	Selects an instrument default setting	(↗ 6-166)



5.5.2.2 STATUS Menu

Function key assignment

	Displays the current instrument settings	(↗ 6-167)
---	--	-----------





5.5.2.3 FILE Menu

Function key assignment

	Saves a user-defined setting	(↗ 6-169)
	Loads a user-defined setting	(↗ 6-169)
	Prints out a screenshot	(↗ 6-171)

5.5.2.4 CONFIG Menu

Function key assignment

	Sets the date and time	(↗ 6-175)
	Selects an internal or external reference source	(↗ 6-177)
	Configures the instrument interfaces	(↗ 6-178)
	Sets the screen saver mode	(↗ 6-181)
	Selects an internal or external monitor	(↗ 6-183)

5.5.2.5 SERVICE Menu

Function key assignment

	Performs a selftest	(↗ 6-184)
---	---------------------	-----------

5.5.2.6 INFO Menu

Function key
assignment

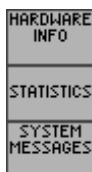

- | | |
|--------------------------------|-----------|
| Displays module data | (↗ 6-186) |
| Displays instrument statistics | (↗ 6-186) |
| Displays system messages | (↗ 6-187) |

6 Using the R&S SM300

This chapter

Chapter 6 describes all signal generator functions and their use. The order in which the menus are described follows that of the procedures for configuring and making available an output signal:

- R&S SM300 default settings
- Setting signal parameters
- Selecting and configuring the output signals

Further information

The operating concept is explained in chapter 5, which also contains an overview of the menus and functions.

The index at the end of this manual will also help you find the information you want.

6.1 Factory Default Settings

Switching on for the first time

When the R&S SM300 (↗ 3-42) is switched on, the settings used when the instrument was last switched off are restored.

When the instrument is switched on for the first time, the factory default settings are activated:

Parameter	Setting
RF frequency	100 MHz
RF level	-30 dBm
LF frequency	1 kHz
LF level	100 mV
Reference frequency	internal
Frequency offset	0 Hz
Level offset	0 dB
Modulations	switched off
Manual level correction	switched off
Sweep	switched off
Memory sequence	switched off
Stored settings	unchanged
Stored data, lists	unchanged

NOTE

The factory default setting is stored in non-volatile memory in the R&S SM300 and can be reloaded whenever required (↗ 6-168).

6.2 Signal Generator

Introduction

The task of the signal generator is to produce unmodulated and modulated signals in a frequency range from 9 kHz to 3 GHz. In addition, LF signals in the range from 20 Hz to 80 kHz can be output at the LF output on the front.

User interface

After switching on the R&S SM300, the user interface of the signal generator is active. In the default state, the following is displayed.

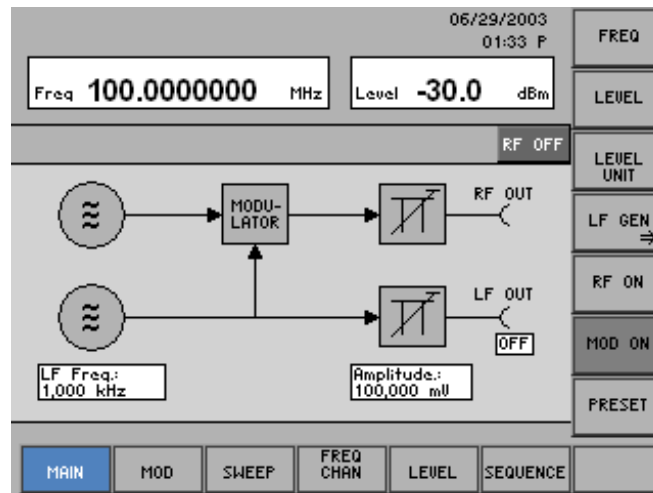

Menus for configuring and setting output parameters

The menus used to set the generator functions are displayed in the menu area. Each menu contains specific functions for configuring the output signal. Frequently used settings such as frequency (FREQ), level (LEVEL), RF ON/OFF and MOD ON/OFF can be made in the MAIN menu. Further parameters can be set in the following menus.

MAIN	Setting of Main Parameters (MAIN menu)	(↗ 6-73)
MOD	Modulation Settings (MOD menu)	(↗ 6-80)
SWEEP	Sweep Settings (SWEEP Menu)	(↗ 6-99)
FREQ CHAN	Special Frequency Settings (FREQ CHAN Menu)	(↗ 6-117)
LEVEL	Special Level Settings (LEVEL Menu)	(↗ 6-134)
SEQUENCE	User-Defined Sequences of Settings (SEQUENCE Menu)	(↗ 6-148)

6.2.1 Setting of Main Parameters (MAIN menu)

What the settings are for

Selecting the MAIN menu

In the MAIN menu, frequently used function keys are highlighted so that the generator can be quickly set.

- Select the **MAIN** menu with the ◀ or ▶ cursor key [6].

The menu name is highlighted and the appropriate functions are assigned to the function keys [13].

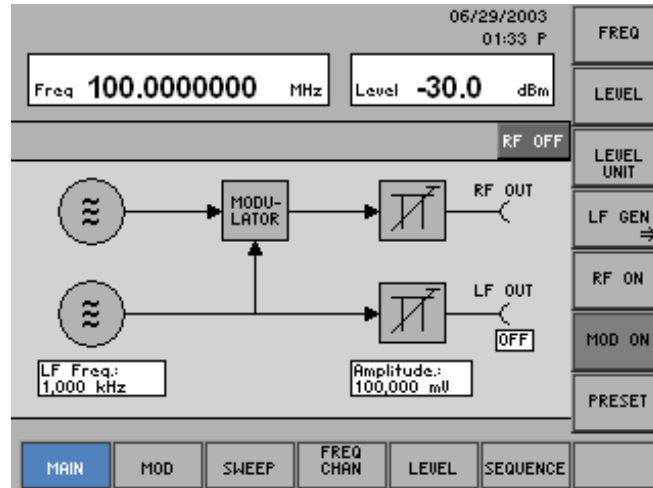

Function key assignment

FREQ	Entering the signal generator output frequency	(↗ 6-74)
LEVEL	Entering the signal generator output level	(↗ 6-74)
LEVEL UNIT	Selecting the unit for the output level	(↗ 6-74)
LF GEN →	Open submenu: Configuring the LF signal	(↗ 6-76)
RF ON	Switching the generator output signal on/off	(↗ 6-74)
MOD ON	Switching the modulation on/off	(↗ 6-78)
PRESET	Loading default setting of R&S SM300	(↗ 6-79)

NOTE

The **MOD ON** function key is only available if a modulation mode was switched on (↗ 6-80).

6.2.1.1 Configuring the RF Signal

NOTE

If after switching on the R&S SM300 the RF output [9] is switched off the message "You must switch on the RF output to get an output signal" appears and there is no output signal. But you can switch on the RF output always (↗ 6-75).

Use

Using the setting parameters, the RF output signal can be adapted to the measurement task. The two main parameters are frequency and output level. The RF signal can additionally be modulated with an internal or external LF signal (↗ 6-80).

Entering the RF output frequency

1. Press the **FREQ** function key in the **MAIN** menu.

An entry field containing the current setting is displayed. The default setting is 100 MHz.



2. Enter a new value in 0.1 dB steps (↗ 5-58).

The frequency entry range is:

$$9 \text{ kHz} \leq \text{Frequency} \leq 3 \text{ GHz}$$

The new setting is displayed and the generator output signal is reconfigured.

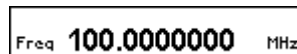

Entering the RF output level

3. Press the **LEVEL** function key in the **MAIN** menu.

An entry field containing the current setting is displayed. The default setting is -30 dBm.



4. Enter a new value in 0.1 dB steps (↗ 5-58).

The level entry range is:

$$-127 \text{ dBm} \leq \text{Level} \leq +13 \text{ dBm}$$

The new setting is displayed and the generator output signal is reconfigured.

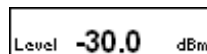

Selecting the unit for the output level

5. Press the **LEVEL UNIT** function key in the **MAIN** menu.

A selection field containing the available settings is displayed. The default setting is dBm.

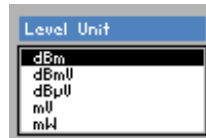

6. Select a setting with the **rotary knob** [11].

The current level is immediately converted to the new unit.

7. Press the **ENTER** key [5] to close the selection field.

The new setting is saved and displayed in the parameter field, e.g. dBµV.

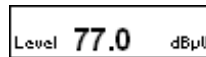

Switching the RF output on/off

8. Press the **RF ON** function key in the **MAIN** menu.

The function key is highlighted and the RF output is active. The output signal with the currently set parameters is present. RF ON is displayed in the status line.



To deactivate the RF output, press the **RF ON** function key in the **MAIN** menu.

The function key is no longer highlighted and an output signal is no longer present at the RF output. RF OFF is displayed in the status line.



NOTE

The set output frequency is independent of the frequencies set under SWEEP menu (↗ 6-100). If the frequency sweep function is active, the frequency cannot be set here.

The set output level is independent of the levels set under SWEEP menu (↗ 6-106). If the level sweep function is active, the level cannot be set here.

6.2.1.2 Configuring the LF Signal

What the settings are for

An LF signal from 20 Hz to 80 kHz is available at the BNC connector LF OUT [9] on the front panel next to the RF output RF OUT [8]. Frequency and amplitude of the LF output signal can be configured via the LF GEN OUTPUT submenu. The LF generator also serves as an internal modulation source for the RF signal.



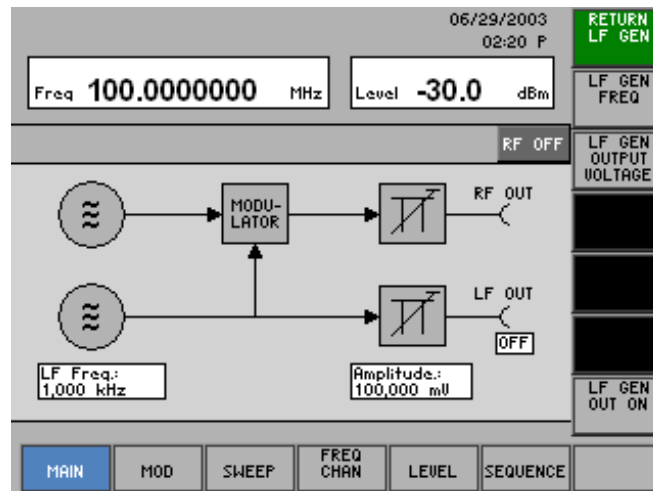

Selecting the LF GEN submenu

- Press the  function key in the  menu.

The submenu is opened and the respective functions are assigned to the function keys [13].



Function key assignment

	Quitting the submenu	
	Entering the LF generator output frequency	(↗ 6-77)
	Entering the LF generator output level	(↗ 6-77)
	Switching the output signal of the LF generator on/off	(↗ 6-77)

6.2.1.2.1 Setting LF Parameters

Use

In the R&S SM300, an LF signal can be configured by setting frequency and amplitude. The LF signal also serves as a modulation source (➤ 6-80).

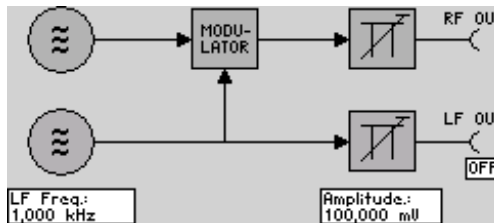

Entering the LF output frequency

1. Press the **LF GEN FREQ** function key in the **LF GEN** submenu.

An entry field containing the current setting is displayed. The default setting is 1 kHz.



2. Enter a new value in 0.1 Hz steps (➤ 5-58).
The frequency entry range is:

$$20 \text{ Hz} \leq \text{LF Frequency} \leq 80 \text{ kHz}$$

The new setting is displayed and the LF generator output signal is reconfigured.

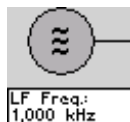

Entering the LF output level

3. Press the **LF GEN OUTPUT VOLTAGE** function key in the **LF GEN** submenu.

An entry field containing the current setting is displayed. The default setting is 100 mV.



4. Enter a new value in 1 mV steps (➤ 5-58).
The level entry range is:

$$1 \text{ mV} \leq \text{LF Output Voltage} \leq 2 \text{ V}$$

The new setting is displayed and the LF generator output signal is reconfigured.

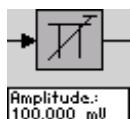

NOTE



When the LF generator is used as a modulation source, only the LF GEN FREQ parameter has an effect on the signal to be modulated. The LF GEN OUTPUT VOLTAGE setting only affects the LF output and not the signal to be modulated.

Switching the LF output on/off

5. Press the  function key in the  submenu.

The function key is **highlighted** and the LF output is active. A sinewave signal containing the current output parameters is present.



- To deactivate the LF output, press again the  function key in the  submenu.

The function key is **no longer** highlighted and a signal is no longer present at the LF output.



6.2.1.3 Switching on the Modulation

Use

After setting the desired modulation mode(s) in the MOD menu (↗ 6-80), you can also quickly switch the modulation of the RF signal on and off in the MAIN menu (↗ below).

Switching the modulation on

1. Press the  function key in the  menu.

The function key is highlighted and the modulated RF signal is present at the RF output. The current modulation mode(s) are displayed in the status line, e. g. amplitude modulation (AM).



Switching the modulation off

2. Press the  function key in the  menu.

The function key is **no longer** highlighted and the unmodulated RF signal is present at the RF output. The modulation mode(s) in the status line are blanked.

NOTE

The  function key is only available if at least one modulation mode was selected. (↗ 6-80).

6.2.1.4 Loading the Default Setting

Use

After switching on the R&S SM300 (↗ 3-42), the settings used when the instrument was last switched off are restored.

The R&S SM300 also lets you save and call user-defined instrument settings (↗ 6-168). If you frequently use one of these settings and want to load it quickly, you can define this setting to be the PRESET (↗ 6-165) and call it directly in the MAIN menu whenever required (↗ below).

Loading the default setting

1. Press the  function key in the  menu.

A text window is opened where you are asked whether the default setting should be loaded.

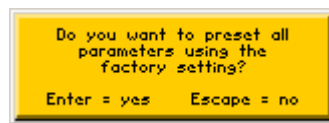

2. Press the **ENTER key** [5] to load the default setting.
If the current instrument setting should remain active, press the **ESC/CANCEL key** [4].

The text window is closed.

NOTE

If no user-defined setting has yet been defined as the default setting, the **FACTORY**, i.e. the factory default setting, is assigned to the  function key (↗ 6-71).

6.2.2 Modulation Settings (MOD menu)

What the settings are for

In the MOD menu, the RF signal can be modulated in different ways.

- **AM** (amplitude modulation)
- **FM** (frequency modulation)
- **PM** (phase modulation)
- **PULSE MOD** (pulse modulation)
- **I/Q** (I/Q modulation)



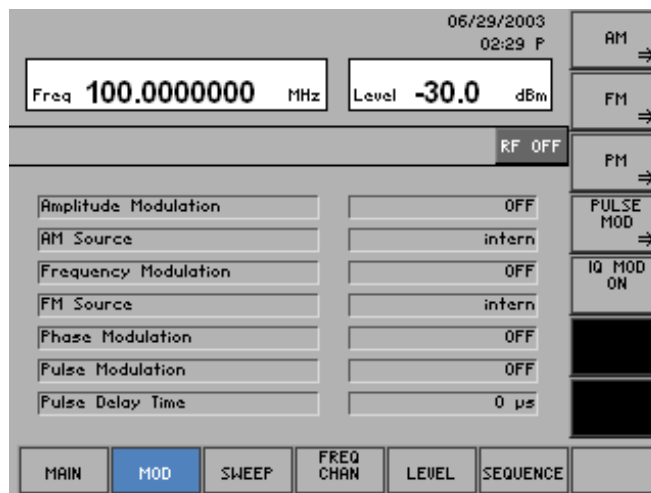

Selecting the MOD menu

- Select the **MOD** menu using the **◀** or **▶** cursor key [6].

The menu name is highlighted and the appropriate functions are assigned to the function keys [13]. The global parameters of all modulation modes are displayed in the parameter field.



Function key assignment

	Open submenu: Setting the amplitude modulation	(↗ 6-81)
	Open submenu: Setting the frequency modulation	(↗ 6-86)
	Open submenu: Setting the phase modulation	(↗ 6-91)
	Open submenu: Setting the pulse modulation	(↗ 6-94)
	Switching I/Q modulation on/off	(↗ 6-98)

6.2.2.1 Amplitude Modulation (AM)

What the settings are for

Selecting the AM submenu





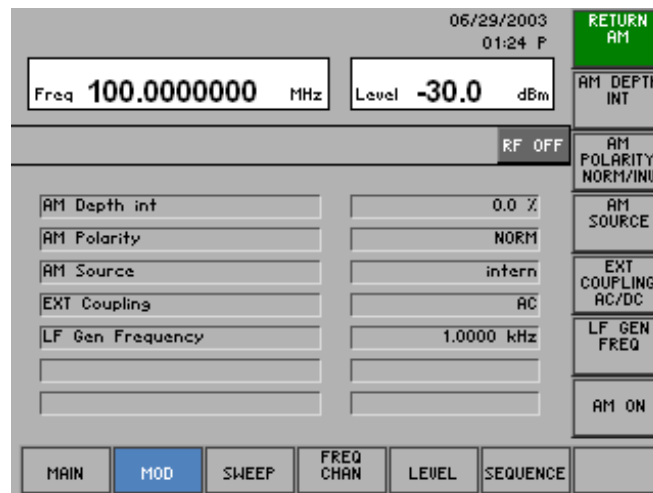

In the AM submenu, the specific amplitude modulation parameters can be set.

- Press the  function key in the  menu.

The submenu is opened and the respective functions are assigned to the function keys [13]. The current AM modulation settings are displayed in the parameter field.



Function key assignment

	Quitting the submenu	
	Entering the modulation depth	(↗ 6-82)
	Setting the polarity of the modulation voltage	(↗ 6-83)
	Selecting the modulation source	(↗ 6-84)
	Setting coupling of external LF generator	(↗ 6-84)
	Entering the frequency of the internal LF generator	(↗ 6-85)
	Switching modulation on/off	(↗ 6-85)

6.2.2.1.1 Entering the Modulation Depth

Use The AM modulation depth m describes the ratio of the maximum to the minimum amplitude A of the modulated signal.

$$m = \frac{A_{\max} - A_{\min}}{A_{\max} + A_{\min}}$$

Entering the modulation depth

1. Press the  function key in the  submenu.

An entry field containing the current setting is displayed. The default setting is 0 %.



2. Enter a new value in 0.1 % steps (↗ 5-58).

The modulation depth entry range is:

$$0 \% \leq \text{AM Depth} \leq 100 \%$$

The new setting is saved and displayed in the parameter field.

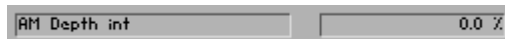

NOTE

If external and internal modulation (↗ 6-84) is set at the same time, make sure that the maximum modulation depth does not exceed 100 %.

6.2.2.1.2 Setting the Polarity of the Modulation Voltage

NOTE

The polarity of the modulation voltage can only be set if "external" or "int + ext" has been selected for the modulation source (➔ 6-84).

Use

In addition to the polarity of the modulation voltage, the sign can be selected so that the output signal frequency is changed as a function of the modulation voltage.

- **NORM**

If NORM is selected, a modulation voltage > 0 V increases the signal amplitude. Conversely, the signal amplitude is reduced if the modulation signal voltage is < 0 V.

- **INV**

If INV is selected, a modulation voltage > 0 V reduces the signal amplitude. Conversely, the signal amplitude is increased if the modulation signal voltage is < 0 V.

Selecting the polarity

1. Press the  **function key** in the  **submenu**.

A selection field containing the available settings is displayed. The default setting is NORM.



2. Select a setting with the **rotary knob** [11].
3. Press the **ENTER key** [5] to close the selection field.

The new setting is saved and displayed in the parameter field.



6.2.2.1.3 Selecting a Modulation Source

Use

In the R&S SM300, you can select whether the internal LF generator and/or an external signal at the input [18] is used as a modulation source. Any waveform, e. g. a square-wave signal, can be applied to the external modulation input as modulation signal. If a voltage of $V_{pp} = 1 \text{ V}$ is applied to the external modulation input, the actual modulation depth corresponds to the adjusted modulation depth (↗ 6-82).

Selecting the AM modulation source

1. Press the  function key in the  submenu.

A selection field containing the available settings is displayed. The default setting is "internal".

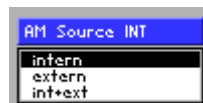

2. Select a setting with the **rotary knob** [11].
3. Press the **ENTER key** [5] to close the selection field.

The new setting is saved and displayed in the parameter field (↗ MOD menu, 6-80).



6.2.2.1.4 Setting the Coupling of the External LF Generator

Use

The external LF signal can be coupled in two different ways:

- **AC**
In the AC default setting, only the AC component of the voltage applied to the external modulation input is used for the modulation.
- **DC**
If the DC component of the signal should not be blocked at the external modulation input, DC coupling can be selected. In the case of AM, the DC component increases the amplitude of the carrier frequency of the modulated signal.

Selecting the coupling mode

1. Press the  function key in the  menu.

A selection field containing the available settings is displayed. The default setting is AC.



2. Select a setting with the **rotary knob** [11].
3. Press the **ENTER key** [5] to close the selection field.

The new setting is saved and displayed in the parameter field.

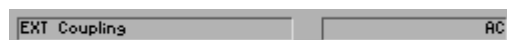

6.2.2.1.5 Setting the Internal LF Generator Frequency

Use

The frequency of the internal LF generator can conveniently be set from any submenu without opening the MAIN menu. Setting the frequency is global and applies to all modulation modes.

Entering the LF frequency

1. Press the  function key in the  submenu.

An entry field containing the current setting is displayed. The default setting is 1 kHz.



2. Enter a new value in 0.1 Hz steps (↻ 5-58).

The frequency entry range is:

$$20 \text{ Hz} \leq \text{LF Frequency} \leq 80 \text{ kHz}$$

The new setting is displayed and the LF generator output signal is reconfigured.



NOTE

The setting "Setting the Internal LF Generator Frequency" has the same function as "Entering the LF output frequency" (↻ 6-77).

6.2.2.1.6 Switching On AM

Use

To activate the AM mode, it must be switched on in the AM submenu.

Switching on AM

1. Press the  function key in the  submenu.

The function key is highlighted. The new setting is saved and displayed in the parameter field (↻ MOD menu, 6-80).



After AM is switched on, the newly modulated RF signal is present at the RF output. "AM" is displayed in the status line.



Switching off AM

2. Press the  function key in the  submenu.

The function key is **no longer** highlighted. The new setting is saved and displayed in the parameter field (↻ MOD menu, 6-80).



Amplitude modulation is switched off and "AM" is blanked in the status line.

NOTE

The selected modulation can also be switched on or off in the MAIN menu (↻ 6-78).

6.2.2.2 Frequency Modulation (FM)

What the settings are for

Selecting the FM submenu





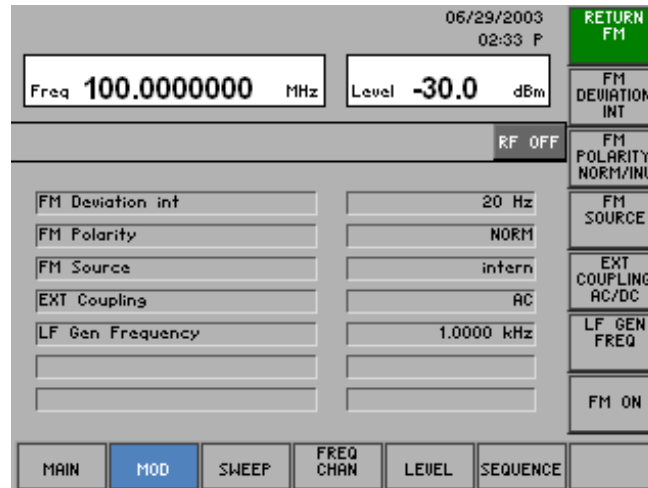

In the FM submenu, the specific frequency modulation parameters can be set.

- Press the  function key in the  menu.

The submenu is opened and the respective functions are assigned to the function keys [13].



Function key assignment

	Quitting the submenu	
	Entering the frequency deviation	(↗ 6-87)
	Setting the polarity of the modulation voltage	(↗ 6-88)
	Selecting the modulation source	(↗ 6-89)
	Setting the coupling of the external LF generator	(↗ 6-89)
	Entering the frequency of the internal LF generator	(↗ 6-90)
	Switching the modulation on/off	(↗ 6-90)

6.2.2.2.1 Entering the Frequency Deviation

Use

The frequency deviation indicates the maximum deviation of the signal frequency from the center frequency, i.e. the output frequency increases or decreases as a function of the amplitude of the modulation signal within specified limits around the center frequency.

Entering the frequency deviation

1. Press the  function key in the  submenu.

An entry field containing the current setting is displayed. The default setting is 20 Hz.



2. Enter a new value in 1 Hz steps (↗ 5-58).

The entry range for the deviation is:

$$20 \text{ Hz} \leq \text{FM Deviation} \leq 100 \text{ kHz}$$

The new setting is saved and displayed in the parameter field.



NOTE

If external and internal modulation (↗ 6-84) are set at the same time, make sure that the maximum frequency deviation of 100 kHz is not exceeded.

6.2.2.2.2 Setting the Polarity of the Modulation Voltage

NOTE

The polarity of the modulation voltage can only be set if "external" or "int + ext" has been selected for the modulation source (➔ 6-84).

Use

In addition to the polarity of the modulation voltage, the sign can be selected so that the output signal frequency changes as a function of the modulation voltage.

- **NORM**

If NORM is selected, a modulation voltage > 0 V increases the signal frequency. Conversely, the signal frequency is reduced if the voltage of the modulation signal is < 0 V.

- **INV**

If INV is selected, a modulation voltage > 0 V reduces the signal frequency. Conversely, the signal frequency is increased if the voltage of the modulation signal is < 0 V.

Selecting the polarity

1. Press the  **function key** in the  **submenu**.

A selection field containing the available settings is displayed. The default setting is NORM.



2. Select a setting with the **rotary knob** [11].
3. Press the **ENTER key** [5] to close the selection field.
The new setting is saved.

6.2.2.2.3 Selecting the Modulation Source

Use

In the R&S SM300, you can select whether the internal LF generator and/or an external signal at the input [18] is used as a modulation source. The advantage of an external signal source is that any waveform, e. g. a square-wave signal, can be used. If a voltage of $V_{pp} = 1\text{ V}$ is applied to the external modulation input, the actual frequency deviation corresponds to the adjusted frequency deviation (\nearrow 6-87).

Selecting the FM modulation source

1. Press the  function key in the  submenu.

A selection field containing the available settings is displayed. The default setting is "internal".

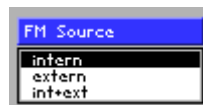

2. Select a setting with the **rotary knob** [11].
3. Press the **ENTER key** [5] to close the selection field.
The new setting is saved and displayed in the parameter field.

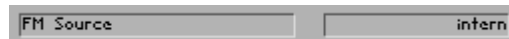

6.2.2.2.4 Setting the Coupling of the External LF Generator

Use

The external LF signal can be coupled in two different ways:

- **AC**
In the AC default setting, only the AC component of the voltage applied to the external modulation input is used for the modulation.
- **DC**
If the DC component of the signal should not be blocked at the external modulation input, DC coupling can be selected.

Selecting the coupling mode

1. Press the  function key in the  submenu.

A selection field containing the available settings is displayed. The default setting is AC.



2. Select a setting with the **rotary knob** [11].
3. Press the **ENTER key** [5] to close the selection field.
The new setting is saved and displayed in the parameter field.



6.2.2.2.5 Setting the Internal LF Generator Frequency

Use

The frequency of the internal LF generator can conveniently be set from any submenu without opening the MAIN menu. Setting the frequency is global and applies to all modulation modes.

Entering the LF frequency

1. Press the  function key in the  submenu.

An entry field containing the current setting is displayed. The default setting is 1 kHz.



2. Enter a new value in 0.1 Hz steps (↗ 5-58).
The frequency entry range is:

$$20 \text{ Hz} \leq \text{LF Frequency} \leq 80 \text{ kHz}$$

The new setting is displayed and the LF generator output signal is reconfigured.



NOTE

The setting "Setting the Internal LF Generator Frequency" has the same function as "Entering the LF output frequency" (↗ 6-77).

6.2.2.2.6 Switching On FM

Use

To activate the FM mode, it must be switched on in the FM submenu.

Switching FM on

1. Press the  function key in the  submenu.

The function key is highlighted. The new setting is saved and displayed in the parameter field (↗ MOD menu, 6-80).



After FM is switched on, the newly modulated RF signal is present at the RF output. "FM" is displayed in the status line.



Switching FM off

2. Press the  function key in the  submenu.

The function key is **no longer** highlighted. The new setting is saved and displayed in the parameter field (↗ MOD menu, 6-80).

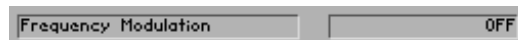

Frequency modulation is switched off and "FM" is blanked in the status line.

NOTE

The selected modulation can also be switched on or off in the MAIN menu (↗ 6-78).

6.2.2.3 Phase Modulation (ϕ M)

What the settings are for

Selecting the ϕ M submenu



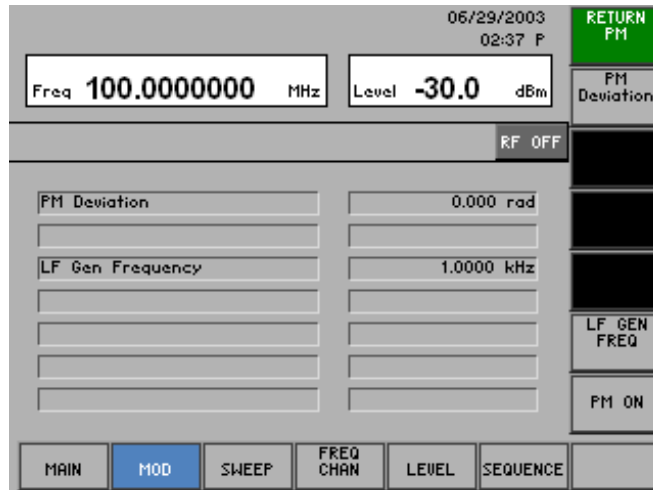

In the ϕ M submenu, the specific phase modulation parameters can be set.

- Press the  function key in the  menu.

The submenu is opened and the respective functions are assigned to the function keys [13].



Function key assignment

	Quitting the submenu	
	Entering the ϕ M deviation	(↗ 6-92)
	Entering the frequency of the internal LF generator	(↗ 6-93)
	Switching the modulation on/off	(↗ 6-93)

6.2.2.3.1 Entering the ϕ M Deviation

Use

The phase modulation on the transmitter side is basically the same as the frequency modulation (↗ 6-86). The main difference is the input of the frequency deviation, which in the case of phase modulation relative to modulation frequency is entered in rad.

$$\phi\text{M Deviation} = \text{FM Deviation} / \text{LF Frequency} [\text{rad}]$$

Entering the ϕ M deviation

1. Press the  function key in the  submenu.

An entry field containing the current setting is displayed. The default setting is 0 rad.



2. Enter a new value in 1 rad steps (↗ 5-58).

The entry range for the deviation is:

$$0 \text{ rad} \leq \phi\text{M Deviation} \leq 10 \text{ rad}$$

The new setting is saved and displayed in the parameter field.



NOTE

The maximum permissible frequency deviation of 100 kHz must not be exceeded in the selected ϕ M mode. The following applies:

$$\phi\text{M Deviation} * \text{LF Frequency} \leq 100 \text{ kHz}$$

The value of 10 rad can be set only if the modulation frequency \leq 10 kHz.

6.2.2.3.2 Setting the Internal LF Generator Frequency

Use

The frequency of the internal LF generator can conveniently be set from any submenu without opening the MAIN menu. Setting the frequency is global and applies to all modulation modes.

Entering the LF frequency

1. Press the  function key in the  submenu.

An entry field containing the current setting is displayed. The default setting is 1 kHz.



2. Enter a new value in 0.1 Hz steps (↗ 5-58).
The frequency entry range is:

$$20 \text{ Hz} \leq \text{LF Frequency} \leq 80 \text{ kHz}$$

The new setting is displayed and the LF generator output signal is reconfigured.



NOTE

The setting "Setting the Internal LF Generator Frequency" has the same function as "Entering the LF output frequency" (↗ 6-77).

6.2.2.3.3 Switching on φM

Use

To activate the φM mode, it must be switched on in the φM submenu.

Switching φM on

1. Press the  function key in the  submenu.

The function key is highlighted. The new setting is saved and displayed in the parameter field (↗ MOD menu, 6-80).



After switching on, the newly modulated RF signal is present at the RF output. "φM" is displayed in the status line.



Switching φM off

2. Press the  function key in the  submenu.

The function key is **no longer** highlighted. The new setting is saved and displayed in the parameter field (↗ MOD menu, 6-80).



Phase modulation is switched off and "φM" is blanked in the status line.

NOTE

The selected modulation can also be switched on or off in the MAIN menu (↗ 6-78).

6.2.2.4 Pulse Modulation (PULSE MOD)

What the settings are for

Selecting the PULSE MOD submenu





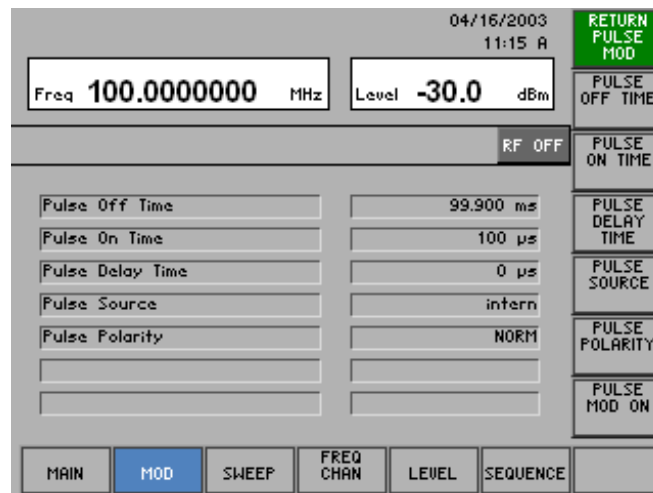

In the PULSE MOD submenu, you can set the specific parameters for pulse modulation.

- Press the  function key in the  menu.

The submenu is opened and the respective functions are assigned to the function keys [13]. The current PULSE MOD modulation settings are displayed in the parameter field.



Function key assignment

	Quitting the submenu	
	Entering the pulse off time	(↗ 6-95)
	Entering the pulse on time	(↗ 6-95)
	Entering the pulse delay time	(↗ 6-96)
	Selecting the modulation source	(↗ 6-96)
	Setting the pulse polarity	(↗ 6-97)
	Switching the modulation on/off	(↗ 6-97)

6.2.2.4.1 Entering the Pulse Off Time

Use The PULSE OFF TIME function is used to set the off time of the pulsed RF signal.

Entering the pulse off time

1. Press the  function key in the  submenu.

An entry field containing the current setting is displayed. The default setting is 99.9 ms.



2. Enter a new value in 0.1 ms steps (↗ 5-58).
The entry range for the pulse off time is:

$$100 \mu\text{s} \leq \text{PWM Pulse Off} \leq 1 \text{ s}$$

The new setting is saved and displayed in the parameter field.

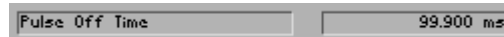

6.2.2.4.2 Entering the Pulse On Time

Use The PULSE ON TIME function is used to set the width of the pulsed RF signal.

Entering the pulse on time

1. Press the  function key in the  submenu.

An entry field containing the current setting is displayed. The default setting is 100 μs.



2. Enter a new value in 1 μs steps (↗ 5-58).
The entry range for the pulse on time is:

$$100 \mu\text{s} \leq \text{PWM Pulse Delay} \leq 1 \text{ s}$$

The new setting is saved and displayed in the parameter field.

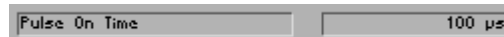

6.2.2.4.3 Entering the Pulse Delay Time

Use

If external pulse modulation is selected, a pulse delay can be set between the external modulation signal and the pulsed RF signal.

Entering the pulse delay time

1. Press the  **function key** in the  **submenu**.

An entry field containing the current setting is displayed. The default setting is 0 μ s.



2. Enter a new value in 1 μ s steps (\nearrow 5-58).
The entry range for the pulse delay is:

$$0 \text{ s} \leq \text{PWM Pulse Delay} \leq 1 \text{ s}$$

The new setting is saved and displayed in the parameter field.



6.2.2.4.4 Selecting the Pulse Modulation Source

Use

In the R&S SM300, you can select whether the internal pulse generator and/or an external signal at the input [18] is used as a modulation source.

Selecting the PULSE MOD modulation source

1. Press the  **function key** in the  **submenu**.

A selection field containing the available settings is displayed. The default setting is "internal".



2. Select a setting with the **rotary knob** [11].
3. Press the **ENTER key** [5] to close the selection field.

The new setting is saved and displayed in the parameter field.

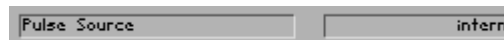

6.2.2.4.5 Setting the External Pulse Polarity

Use

The setting PULSE POLARITY allows to determine whether the signal at the input socket EXT PULSE MOD IN [17] is inverted or not.

- **NORM**
The external signal will be **not** inverted.
- **INV**
The external signal will be inverted.

Selecting the polarity

1. Press the  function key in the  submenu.

A selection field containing the available settings is displayed. The default setting is NORM.



2. Select a setting with the **rotary knob** [11].
3. Press the **ENTER key** [5] to close the selection field.

The new setting is saved and displayed in the parameter field.



6.2.2.4.6 Switching PULSE MOD On

Use

To activate the PULSE MOD mode, it must be switched on in the PULSE MOD submenu.

Switching PULSE MOD on

1. Press the  function key in the  submenu.

The function key is highlighted. The new setting is saved and displayed in the parameter field (↗ MOD menu, 6-80) .



After PULSE MOD is switched on, the pulse-modulated signal is present at the RF output. "PULSE MOD" is displayed in the status line.



Switching PULSE MOD off

2. Press the  function key in the  submenu.

The function key is **no longer** highlighted. The new setting is saved and displayed in the parameter field (↗ MOD menu, 6-80) .



Amplitude modulation is switched off and "PULSE MOD" is blanked in the status line.

NOTE

The selected modulation can also be switched on or off in the MAIN menu (↗ 6-78).

6.2.2.5 I/Q Modulation

Use

With the IQ MOD function, virtually any desired output signal can be generated, such as those needed in digital mobile radio. The I and Q signals necessary for this must be provided by an arbitrary generator (e. g. R&S AMIQ). The I/Q outputs of the arbitrary generator are connected with the I/Q inputs of the R&S SM300 [15, 16] via two identical cables with BNC connectors. You obtain the modulated signal at the RF output of the R&S SM300 after the I/Q MOD function has been switched on and I/Q signals are applied to the inputs.

NOTE

The rms value and the peak value of the signal change vis-à-vis the unmodulated signal as a result of the modulation with external I/Q signals. The level set in the R&S SM300 applies to the unmodulated signal and is no longer directly related to the level of the modulated signal. Depending on the modulation, signal peaks can occur which lie high above the set level value (e. g. in the case of CDMA signals).

Switching I/Q modulation on

1. Press the  function key in the  submenu.

The function key is highlighted. The new setting is saved.

After I/Q modulation is switched on, the newly modulated RF signal is present at the RF output. "IQ" is displayed in the status line.



Switching I/Q modulation off

2. Press the  function key in the  submenu.

The function key is **no longer** highlighted. The new setting is saved.

I/Q modulation is switched off and "IQ" is blanked in the status line.

NOTE

The selected modulation can also be switched on or off in the MAIN menu (↗ 6-78).

6.2.3 Sweep Settings (SWEEP Menu)

What the settings are for

Selecting the SWEEP menu



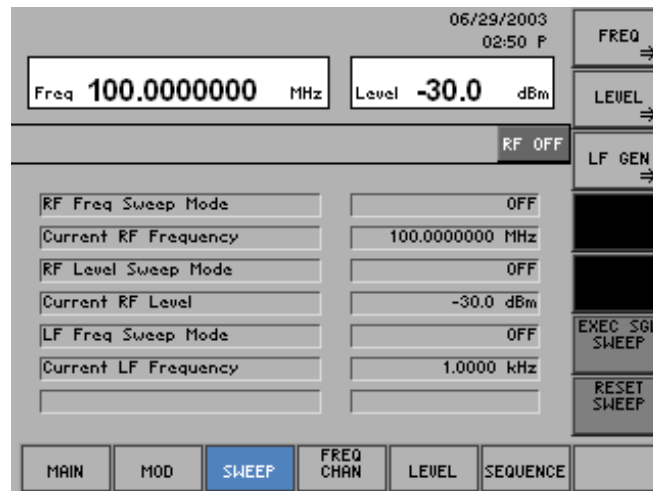

In the SWEEP menu, you can make all the settings to sweep either the RF frequency, the LF frequency or the level of the RF signal.

- Select the **SWEEP** menu using the ◀ or ▶ **cursor key** [6].

The menu name is highlighted and the appropriate functions are assigned to the function keys [13].



Function key assignment

	Open submenu: Configuring the frequency sweep	(↗ 6-100)
	Open submenu: Configuring the level sweep	(↗ 6-106)
	Open submenu: Configuring the frequency sweep of the internal LF generator	(↗ 6-111)
	Starting a single sweep	(↗ 6-104, 6-109, 6-115)
	Resetting an ongoing sweep	(↗ 6-104, 6-109, 6-115)

NOTE

The  function key is only available if the SINGLE SWEEP mode has been set (↗ 6-104, 6-109, 6-115).

The  is only available if the sweep mode has been set (↗ 6-104, 6-109, 6-115).

6.2.3.1 Signal Generator Frequency Sweep

NOTE

The signal generator RF frequency sweep, RF level sweep and LF frequency sweep functions cannot be active simultaneously.

What the settings are for

The frequency sweep function is used to change the signal generator output frequency in a defined frequency range. The FREQ submenu contains all the settings for configuring the sweep.

Selecting the FREQ submenu

- Press the **FREQ** function key in the **SWEEP** menu.

The submenu is opened and the respective functions are assigned to the function keys [13].

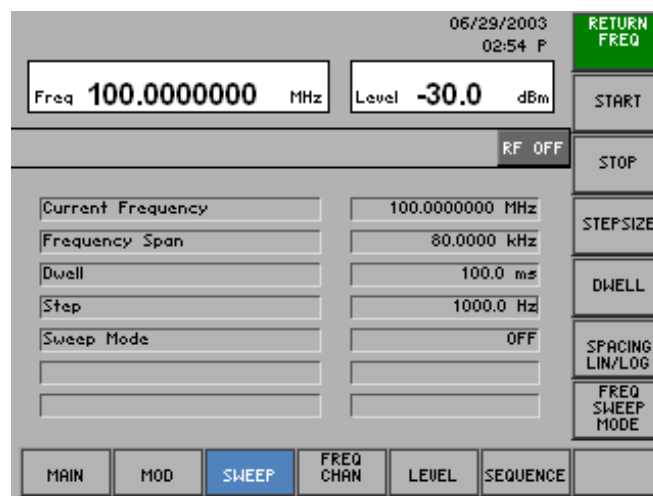

Function key assignment

RETURN FREQ	Quitting the submenu	
START	Entering a start frequency	(↗ 6-101)
STOP	Entering a stop frequency	(↗ 6-101)
STEPSIZE	Entering a step size	(↗ 6-102)
DWELL	Entering a dwell time per step	(↗ 6-102)
SPACING LIN/LOG	Setting sweep spacing	(↗ 6-102)
FREQ SWEEP MODE	Setting/starting the sweep mode	(↗ 6-104)

6.2.3.1.1 Entering the RF Range

Use

By entering a START and STOP frequency, you can select the range within which the output frequency should change.

Entering a start frequency

1. Press the **START** function key in the **FREQ** submenu.

An entry field containing the current setting is displayed. The default setting is 20 kHz.



2. Enter a new value in 0.1 Hz steps (↗ 5-58).
The entry range for the start frequency is:

$$9 \text{ kHz} \leq \text{Sweep Freq Start} < 3 \text{ GHz}$$

The new setting is saved, and the parameter field displays the frequency range (span), which is the difference between the stop and start frequencies (span = stop - start), e. g.:



Entering a stop frequency

3. Press the **STOP** function key in the **FREQ** submenu.

An entry field containing the current setting is displayed. The default setting is 100 kHz.



4. Enter a new value in 0.1 Hz steps (↗ 5-58).
The entry range for the stop frequency is:

$$9 \text{ kHz} \leq \text{Sweep Freq Stop} \leq 3 \text{ GHz}$$

The new setting is saved, and the parameter field displays the frequency range (span), which is the difference between the stop and start frequencies (span = stop - start), e. g.:



NOTE

The frequencies set here are independent of the RF frequency set in the MAIN menu (↗ 6-74).

6.2.3.1.2 Defining the RF Sweep Sequence

Use Using the SPACING, STEPSIZE and DWELL functions, you can define the sequence of the frequency sweep.

Setting sweep spacing

1. Press the  **function key** in the  **submenu**.

A selection field containing the available settings is displayed. The default setting is LIN.

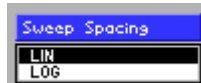

2. Select a setting with the **rotary knob** [11].
3. Press the **ENTER key** [5] to close the selection field.

The new setting is saved, and the parameter field displays the step size in "Hz" or "%" (↵ below).

Entering a step size

4. Press the  **function key** in the  **submenu**.

An entry field containing the current setting is displayed. The value is displayed differently, depending on the type of spacing set. With linear spacing, the current value is given in "kHz"; with logarithmic spacing, it is given in "%". The default setting is 1 kHz or 10 %.



(LIN)



(LOG)

5. Enter a new value in 0.1 Hz steps or 0.01 % steps (↵ 5-58).
The entry range for the step size is:

$$0.1 \text{ Hz} \leq \text{Sweep Freq Step} \leq 1 \text{ GHz} \quad (\text{LIN})$$

$$0.01 \% \leq \text{Sweep Freq Step} \leq 100 \% \quad (\text{LOG})$$

The new setting is saved, and the parameter field displays the step size in "Hz" or "%".



(LIN)



(LOG)

Entering a dwell
time per step

6. Press the **DWELL** function key in the **FREQ** submenu.

An entry field containing the current setting is displayed. The default setting is 100 ms.



7. Enter a new value in 0.1 ms steps (↗ 5-58).
The entry range for the dwell time is:

$$10 \text{ ms} \leq \text{Sweep Freq Dwell} \leq 1 \text{ s}$$

The new setting is saved and displayed in the parameter field.

**NOTE**

The dwell time setting is only effective in the AUTO and SINGLE sweep modes. In the STEP sweep mode, the frequency steps are called using the rotary knob. Thus any desired dwell time is possible.

6.2.3.1.3 Setting/Starting the RF Sweep Mode

Use The RF sweep mode function is used to control the sweep. The following modes are available:

- **OFF**
The sweep is switched off.
- **AUTO**
The sweep is automatically repeated.
- **SINGLE**
The sweep is performed once.
- **STEP**
The sweep is performed step by step.

Setting/starting the sweep mode

1. Press the  **function key** in the  **submenu**.

A selection field containing the available settings is displayed. The default setting is OFF.

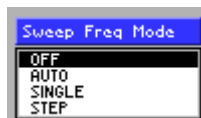

2. Select a setting with the **rotary knob** [11].
3. Press the **ENTER key** [5] to close the selection field.
The new setting is saved and displayed in the parameter field, e.g.:



The Frq-Swp display in the status line provides information about the active RF frequency sweep.

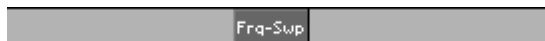

4. Press the  **function key** to quit the  **submenu**.

Performing a single sweep

In the SINGLE sweep mode:

- Press the  **function key** in the  **menu**.

A single sweep is performed in the SINGLE sweep mode. This procedure can be repeated as often as desired.

Performing a sweep step by step

In the STEP sweep mode:

- Turn the **rotary knob** [11] to the left or right.

The sweep is performed step by step. Each time the rotary knob is turned (to the left or right), the next (lower or higher) frequency value is set. This procedure can be repeated as often as desired.





Restarting the ongoing sweep

In every sweep mode:

- Press the  **function key** in the  **menu**.

The ongoing sweep is interrupted and reset to the current start frequency. Subsequently the sweep begins anew (except in the SINGLE sweep mode).

Switching the sweep mode off

1. Press the  function key in the  menu.
2. Press the  function key in the  submenu.

A selection field containing the available settings is displayed.



3. Select **OFF** with **rotary knob** [11].
4. Press the **ENTER key** [5] to close the selection field.

The new setting is saved and displayed in the parameter field.

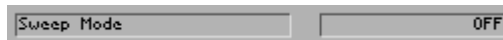

The sweep mode is switched off and "Frq-Swp" is blanked in the status line.

NOTE

If another sweep mode (RF level sweep or LF frequency sweep) was still active when the RF frequency sweep was switched on, it is switched off and the RF frequency sweep is active.

6.2.3.2 Signal Generator Level Sweep

NOTE

The signal generator RF frequency sweep, RF level sweep and LF frequency sweep functions cannot be active simultaneously.

What the settings are for

The level sweep function is used to change the signal generator output level in a defined level range. The LEVEL submenu contains all the settings for configuring the level sweep.

Selecting the LEVEL submenu

- Press the **LEVEL** function key in the **SWEEP** menu.

The submenu is opened and the respective functions are assigned to the function keys [13].

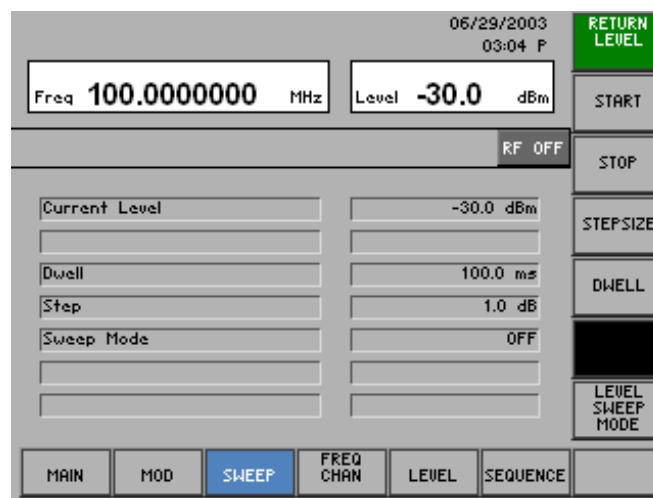

Function key assignment

RETURN LEVEL	Quitting the submenu	
START	Entering a start level	(↗ 6-107)
STOP	Entering a stop level	(↗ 6-107)
STEP SIZE	Entering a step size	(↗ 6-108)
DWELL	Entering a dwell time per step	(↗ 6-108)
LEVEL SWEEP MODE	Setting/starting the sweep mode	(↗ 6-109)

6.2.3.2.1 Entering the RF level range

Use

By entering a start and stop level, you can select the range within which the output frequency should change.

Entering the RF start level

1. Press the **START** function key in the **LEVEL** submenu.

An entry field containing the current setting is displayed. The default setting is -3 dBm.



2. Enter a new value in 0.1 dB steps (↗ 5-58).

The entry range for the start level is:

$$-127 \text{ dBm} \leq \text{Sweep Level Start} \leq +13 \text{ dBm}$$

The new setting is saved and, if the level sweep (↗ 6-109) is active, appears in the level display (↗ below).

Entering the RF stop level

3. Press the **STOP** function key in the **LEVEL** submenu.

An entry field containing the current setting is displayed. The default setting is +3 dBm.



4. Enter a new value in 0.1 dB steps (↗ 5-58).

The entry range for the stop level is:

$$-127 \text{ dBm} \leq \text{Sweep Level Stop} \leq +13 \text{ dBm}$$

The new setting is saved and, if the level sweep (↗ 6-109) is active, appears in the level display (↗ below).

Start	-3.0	dBm
Stop	3.0	dBm

NOTE

The levels set here are independent of the RF level set in the MAIN menu (↗ 6-74). The current RF level is displayed in the parameter field.

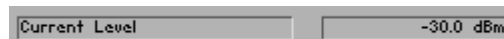

6.2.3.2.2 Defining the Level Sweep Sequence

Use Using the STEPSIZE and DWELL functions, you can define the sequence of the level sweep.

Entering a step size

1. Press the **STEPSIZE** function key in the **LEVEL** submenu.

An entry field containing the current setting is displayed. The default setting is 1 dB.



2. Enter a new value in 0.1 dB steps (↻ 5-58).
The entry range for the step size is:

$$0.1 \text{ dB} \leq \text{Sweep Level Step} \leq 20 \text{ dBm}$$

The new setting is saved and displayed in the parameter field.

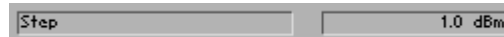

Entering a dwell time per step

3. Press the **DWELL** function key in the **LEVEL** submenu.

An entry field containing the current setting is displayed. The default setting is 100 ms.



4. Enter a new value in 0.1 ms steps (↻ 5-58).
The entry range for the dwell time is:

$$10 \text{ ms} \leq \text{Sweep Level Dwell} \leq 1 \text{ s}$$

The new setting is saved and displayed in the parameter field.

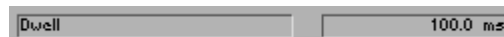

NOTE

The dwell time setting is only effective in the AUTO and SINGLE sweep modes. In the STEP sweep mode, the frequency steps are called using the rotary knob. Thus any desired dwell time is possible.

6.2.3.2.3 Setting/Starting the Level Sweep Mode

Use The level sweep mode function is used to control the sweep. The following modes are available:

- **OFF**
The sweep is switched off.
- **AUTO**
The sweep is automatically repeated.
- **SINGLE**
The sweep is performed once.
- **STEP**
The sweep is performed step by step.

Setting/starting the sweep mode

1. Press the  function key in the  submenu.

A selection field containing the available settings is displayed. The default setting is OFF.

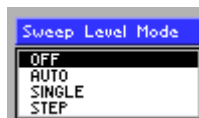

2. Select a setting with the **rotary knob** [11].
3. Press the **ENTER key** [5] to close the selection field.
The new setting is saved and displayed in the parameter field.



The Lev-Swp display in the status line provides information about the active RF level sweep.

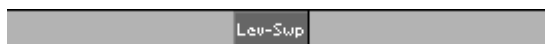

4. Press the  function key to quit the  submenu.

Performing a single sweep

In the SINGLE sweep mode:

- Press the  function key in the  menu.

A single sweep is performed in the SINGLE sweep mode. This procedure can be repeated as often as desired.

Performing a sweep step by step

In the STEP sweep mode:

- Turn the **rotary knob** [11] to the left or right.

The sweep is performed step by step. Each time the rotary knob is turned (to the left or right) the next (lower or higher) level value is set. This procedure can be repeated as often as desired.





Restarting the ongoing sweep

In every sweep mode:

- Press the  function key in the  menu.

The ongoing sweep is interrupted and reset to the current start level. Subsequently the sweep begins anew (except in the SINGLE sweep mode). In the AUTO mode, the sweep begins anew after the reset.

Switching the sweep mode off

1. Press the  function key in the  menu.
2. Press the  function key in the  submenu.

A selection field containing the available settings is displayed.



3. Select **OFF** with rotary knob [11].
4. Press the **ENTER** key [5] to close the selection field.
The new setting is saved and displayed in the parameter field. The sweep mode is switched off and "Lev-Swp" is blanked in the status line.

NOTE

If another sweep mode (RF frequency sweep or LF frequency sweep) was still active when the RF level sweep was switched on, it is switched off and the RF level sweep is active.

6.2.3.3 Frequency Sweep of the Internal LF Generator

NOTE The signal generator RF frequency sweep, RF level sweep and LF frequency sweep functions cannot be active simultaneously.

What the settings are for The frequency sweep function is used to change the output frequency of the LF generator in a defined frequency range. The LF GEN submenu contains all the settings for configuring the sweep.

Selecting the LF GEN submenu

- Press the **LF GEN** function key in the **SWEEP** menu.

The submenu is opened and the respective functions are assigned to the function keys [13].

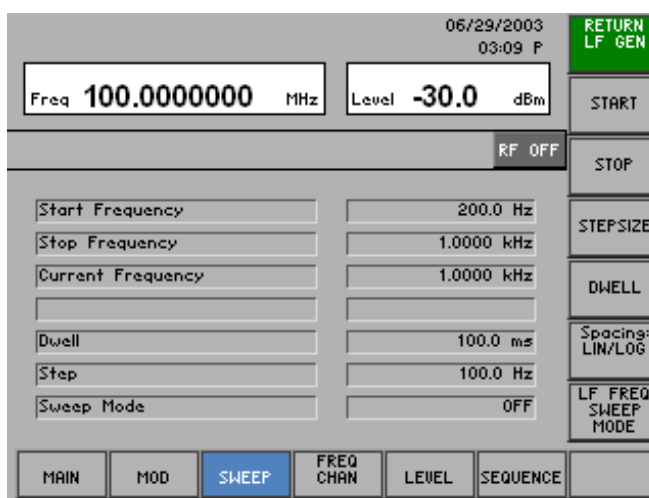

Function key assignment

RETURN LF GEN	Quitting the submenu	
START	Entering a start frequency	(↗ 6-112)
STOP	Entering a stop frequency	(↗ 6-112)
STEP SIZE	Entering a step size	(↗ 6-113)
DWELL	Entering a dwell time per step	(↗ 6-113)
Spacing: LIN/LOG	Setting sweep spacing	(↗ 6-113)
LF FREQ SWEEP MODE	Setting/starting the sweep mode	(↗ 6-115)

6.2.3.3.1 Entering the LF Range

Use

By entering a START and STOP frequency, you can select the range within which the output frequency should change.

Entering the LF start frequency

1. Press the **START** function key in the **LF GEN** submenu.

An entry field containing the current setting is displayed. The default setting is 200 Hz.



2. Enter a new value in 0.1 Hz steps (↗ 5-58).

The entry range for the start frequency is:

$$20 \text{ Hz} \leq \text{Sweep LF Freq Start} \leq 79.999 \text{ kHz}$$

The new setting is saved and displayed in the parameter field.

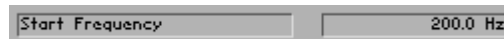

Entering the LF stop frequency

3. Press the **STOP** function key in the **LF GEN** submenu.

An entry field containing the current setting is displayed. The default setting is 10 kHz.



4. Enter a new value in 0.1 Hz steps (↗ 5-58).

The entry range for the stop frequency is:

$$20.1 \text{ Hz} \leq \text{Sweep LF Freq Stop} \leq 80 \text{ kHz}$$

The new setting is saved and displayed in the parameter field.



6.2.3.3.2 Defining the LF Sweep Sequence

Use

Using the SPACING, STEPSIZE and DWELL functions, you can define the sequence of the frequency sweep.

Setting sweep spacing

1. Press the  function key in the  submenu.

A selection field containing the available settings is displayed. The default setting is LIN.



2. Select a setting with the rotary knob [11].
3. Press the ENTER key [5] to close the selection field.

The new setting is saved, and the parameter field displays the step size in "Hz" or "%" (↗ below).

Entering a step size

4. Press the  function key in the  submenu.

An entry field containing the current setting is displayed. The value is displayed differently, depending on the type of spacing set. With linear spacing, the current value is given in "Hz"; with logarithmic spacing, it is given in "%". The default setting is 100 Hz or 10 %.



(LIN)



(LOG)

5. Enter a new value in 0.1 Hz steps or 0.01 % steps (↗ 5-58).
The entry range for the step size is:

$$0.1 \text{ Hz} \leq \text{Sweep LF Freq Step} \leq 80 \text{ kHz} \quad (\text{LIN})$$

$$0.01 \% \leq \text{Sweep LF Freq Step} \leq 100 \% \quad (\text{LOG})$$

The new setting is saved, and the parameter field displays the step size in "Hz" or "%".



(LIN)



(LOG)

Entering a dwell
time per step

6. Press the  function key in the  submenu.

An entry field containing the current setting is displayed. The default setting is 100 ms.



7. Enter a new value in 0.1 ms steps (↗ 5-58).
The entry range for the dwell time is:

$$10 \text{ ms} \leq \text{Sweep LF Freq Dwell} \leq 1 \text{ s}$$

The new setting is saved and displayed in the parameter field.

**NOTE**

The dwell time setting is only effective in the AUTO and SINGLE sweep modes. In the STEP sweep mode, the frequency steps are called using the rotary knob. Thus any desired dwell time is possible.

6.2.3.3.3 Setting/Starting the LF Sweep Mode

Use The LF sweep mode function is used to control the sweep. The following modes are available:

- **OFF**
The sweep is switched off.
- **AUTO**
The sweep is automatically repeated.
- **SINGLE**
The sweep is performed once.
- **STEP**
The sweep is performed step by step.

Setting/starting the sweep mode

1. Press the  **function key** in the  **submenu**.

A selection field containing the available settings is displayed. The default setting is OFF.

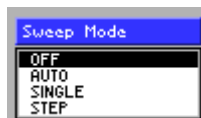

2. Select a setting with the **rotary knob** [11].
3. Press the **ENTER key** [5] to close the selection field.
The new setting is saved and displayed in the parameter field.

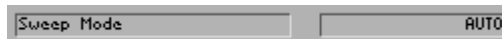

The LF-Swp display in the status line provides information about the active LF frequency sweep.

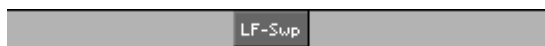

4. Press the  **function key** to quit the  **submenu**.

Performing a single sweep

In the SINGLE sweep mode:

- Press the  **function key** in the  **menu**.

A single sweep is performed in the SINGLE sweep mode. This procedure can be repeated as often as desired.

Performing a sweep step by step

In the STEP sweep mode:

- Turn the **rotary knob** [11] to the left or right.

The sweep is performed step by step. Each time the rotary knob is turned (to the left or right), the next (lower or higher) frequency value is set. This procedure can be repeated as often as desired.

Restarting the ongoing sweep

In every sweep mode:

- Press the  **function key** in the  **menu**.

The ongoing sweep is interrupted and reset to the current start frequency. Subsequently the sweep begins anew (except in the SINGLE sweep mode). In the AUTO mode, the sweep begins anew after the reset.

Switching the sweep mode off

1. Press the  function key in the  menu.

2. Press the  function key in the  submenu.

A selection field containing the available settings is displayed.

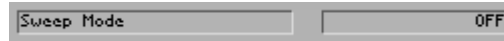

3. Select **OFF** with rotary knob [11].

4. Press the **ENTER** key [5] to close the selection field.

The new setting is saved and displayed in the parameter field. The sweep mode is switched off and "LF-Swp" is blanked in the status line.

NOTE

If another sweep mode (RF frequency sweep or RF level sweep) was still active when the LF frequency sweep was switched on, it is switched off and the LF frequency sweep is active.

6.2.4 Special Frequency Settings (FREQ CHAN Menu)

What the settings are for

In the FREQ CHAN menu, you can make settings that affect the frequency of the output signal. The settings include the entry of a fixed frequency offset, the choice of a step size for the center frequency setting via the rotary knob, the selection of a channel number and the definition of channel lists. In addition, you can define in the menu whether the current frequency setting is to be overwritten when loading new settings.

Selecting the FREQ CHAN menu

- Select the **FREQ CHAN** menu using the ◀ or ▶ cursor key [6].

The menu name is highlighted and the appropriate functions are assigned to the function keys [13].

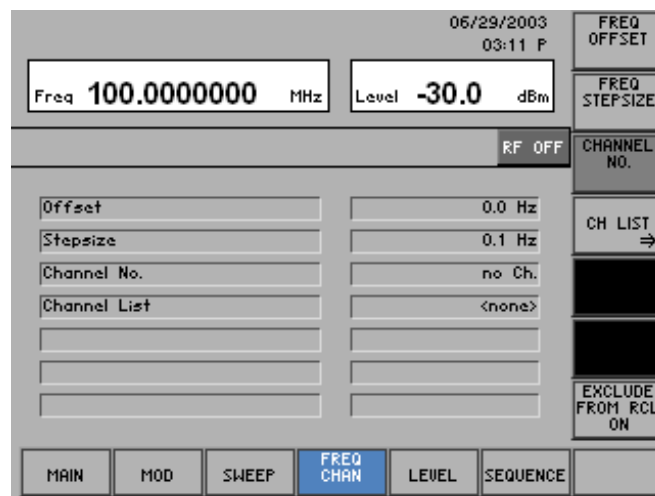

Function key assignment

FREQ OFFSET	Entering the signal generator frequency offset	(↗ 6-118)
FREQ STEPSIZE	Setting the step size for frequency entry with the rotary knob	(↗ 6-119)
CHANNEL NO.	Calling the channel number from the channel list	(↗ 6-132)
CH LIST →	Open submenu: Entry of channel lists	(↗ 6-120)
EXCLUDE FROM RCL ON	Holding the current frequency setting	(↗ 6-133)

NOTE

The **CHANNEL NO.** function key is only available with loaded channel lists (↗ 6-132).

6.2.4.1 Entering the Signal Generator Frequency Offset

Use

A frequency offset can be helpful if the frequency of the output signal is converted to a higher or lower frequency with the aid of a mixer. In this way, the frequency range of the R&S SM300 can be expanded, and the frequency display on the R&S SM300 corresponds to the frequency on the mixer output.

NOTE

Entering an offset does not change the RF output signal but only the displayed frequency value.

Entering the RF frequency offset

1. Press the **FREQ OFFSET** function key in the **FREQ CHAN** menu.

An entry field containing the current setting is displayed. The default setting is 0 kHz.



2. Enter a new value in 0.1 Hz steps (↗ 5-58).

The frequency entry range is:

$$-50 \text{ GHz} \leq \text{Frequency Offset} \leq 50 \text{ GHz}$$

The new setting is saved and displayed in the parameter field, e.g. 1 kHz.

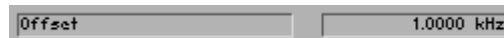

The displayed frequency value increases with a positive offset and decreases with a negative offset.

Frq-Offs is displayed in the status line.



The frequency that was set as the RF output frequency is applied to the signal generator output (↗ 6-74).

6.2.4.2 Setting the Step Size for Frequency Entry with the Rotary Knob

Use

When you enter the frequency using the cursor keys and the rotary knob, the frequency is increased or decreased in steps of a size that you can specify.

Setting the step size

1. Press the  function key in the  menu.

An entry field containing the current setting is displayed. The default setting is 0.1 Hz.



2. Enter a new value in 0.1 Hz steps (↻ 5-58).
The entry range for the step size is:

$$0.1 \text{ Hz} \leq \text{Frequency Stepsize} < 3 \text{ GHz}$$

The new setting is saved and displayed in the parameter field.

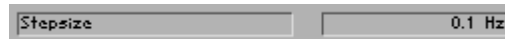

6.2.4.3 Creating Channel Lists

What the settings are for

Using channel lists, you can assign certain frequencies to channel numbers. This function is needed in analog or digital mobile radio, where the frequencies are set in the form of channel numbers. With the digital E-GSM standard, for example, there is the following correlation between the channel frequency and channel number:

TX (transmit band): $f_c = 890 \text{ MHz} + 0.2 \text{ MHz} \cdot n$, for $0 \leq n \leq 124$

RX (receive band): $f_c = f_l(n) = 890 + 0.2 \cdot (n - 1024)$, for $975 \leq n \leq 1023$

The following parameters can be defined in the form of lists:

First channel number:	First Ch.	(e.g. 0)
Last channel number:	Last Ch.	(e.g. 124)
First frequency:	First Freq.	(e.g. 890 MHz)
Channel spacing:	Space Freq.	(e.g. 200 kHz)

It is possible to create a number of different entries in a channel list in order to cover various frequency bands. This allows e. g. the TX and RX band with GSM to be mapped in a list, and the user can switch between the bands by entering a channel number without having to load a new list. The only restriction here is that the channel number ranges cannot overlap.

As many as six lists with 10 entries each can be created.

Selecting the CH LIST submenu

- Press the **CH LIST** function key in the **FREQ CHAN** menu.

The submenu is opened and the respective functions are assigned to the function keys [13].

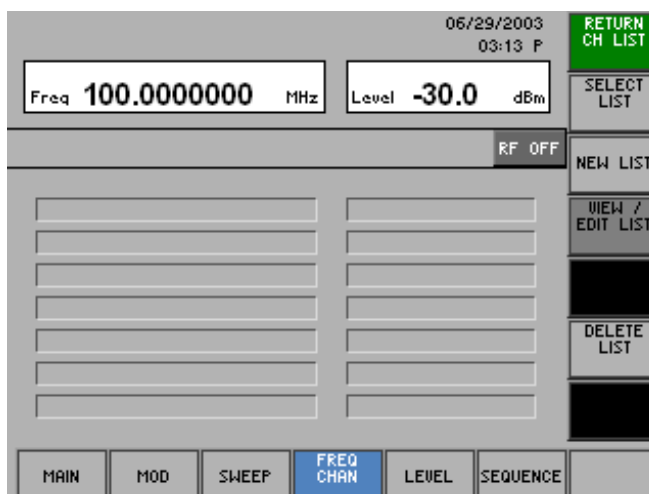

Function key assignment

RETURN CH LIST	Quitting the submenu	
SELECT LIST	Selecting a channel list	(↗ 6-122, 6-132)
NEW LIST	Creating a new channel list	(↗ 6-122)
VIEW / EDIT LIST	Viewing/editing a channel list	(↗ 6-122)
DELETE LIST	Deleting a channel list	(↗ 6-131)

NOTE

The **VIEW / EDIT LIST** function key is only available if a channel list has been selected. (↗ 6-122).

The **NEW LIST** function key is only available if fewer than 6 channel lists have been saved. To create a new list, another one must be deleted.

6.2.4.3.1 Creating/Editing a Channel List

Use Creating, editing and deleting channel lists for entering channel numbers is performed in the CH LIST submenu.

Menu structure for list entry

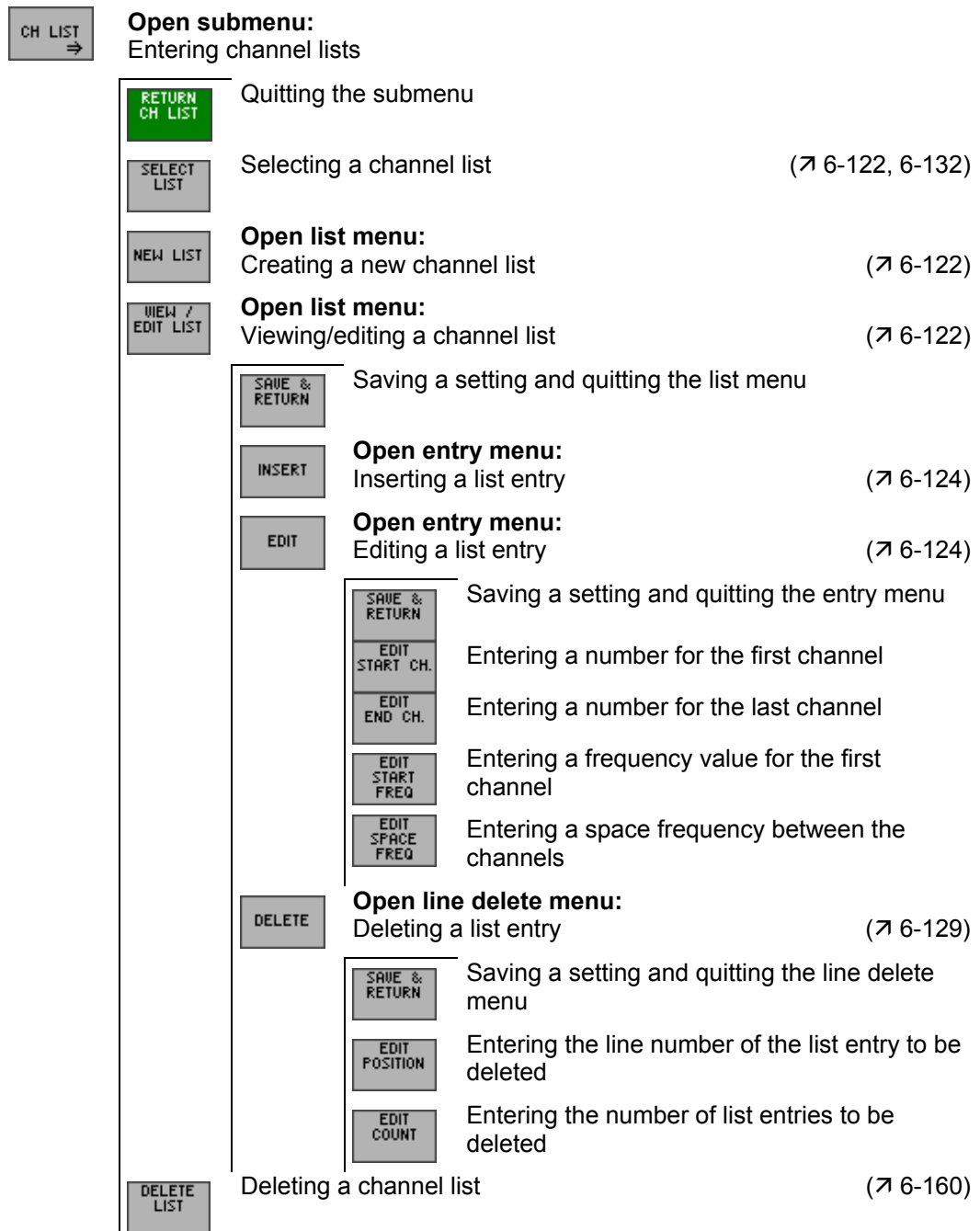

Creating a new channel list

- Press the **NEW LIST** function key in the **CH LIST** submenu.

This takes you directly to the entry menu, where you can insert a list entry (➤ 6-124).

After you complete the first entry, the list menu appears, where you can further edit the channel list (➤ below, "Editing a list entry").

NOTE: If 6 lists already exist, the message "No more channel list can be created" will appear and a channel list has to be deleted first (➤ 6-131).

Selecting a channel list

- Press the **SELECT LIST** function key in the **CH LIST** submenu.

A selection list containing stored channel lists is displayed.



- Select a channel list with the **▲** or **▼** cursor key [7].
- Press the **ENTER** key [5] to close the selection field. The new setting is saved.





Editing a list entry

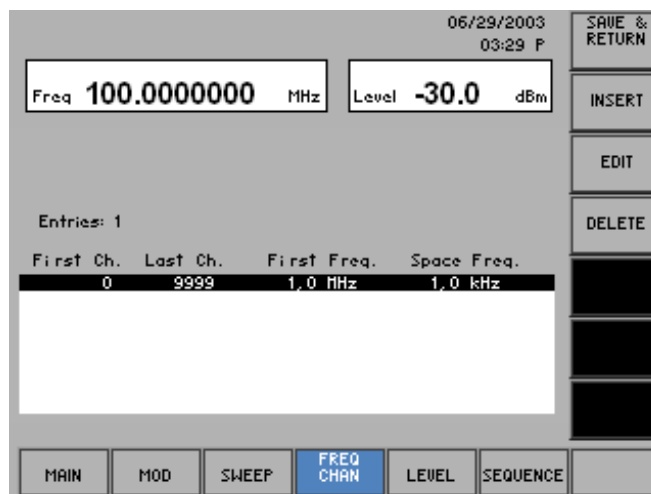

- Press the **VIEW / EDIT LIST** function key in the **CH LIST** submenu.

The list menu containing the current channel list is opened and the respective functions are assigned to the function keys [13].



Function key assignment

	Saving a setting and quitting the list menu	
	Inserting a list entry	(↗ 6-124)
	Editing a list entry	(↗ 6-124)
	Deleting a list entry	(↗ 6-129)

NOTE The  and  function keys are only available if a list entry exists.

Inserting/Editing a List Entry

Use In the list submenu, further entries can be added to a selected list or existing entries can be edited.

The parameters of a list entry are entered in the entry menu.

Selecting a list entry

1. Select the list menu (↗ 6-122).
2. Select a list entry with the ▲ or ▼ **cursor key** [7].

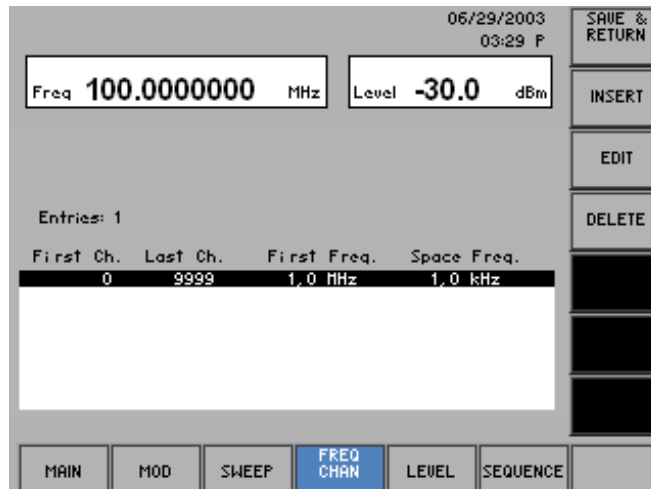

The list entry can either be edited (EDIT) or it serves to mark the position for new subsequent list entries (INSERT).



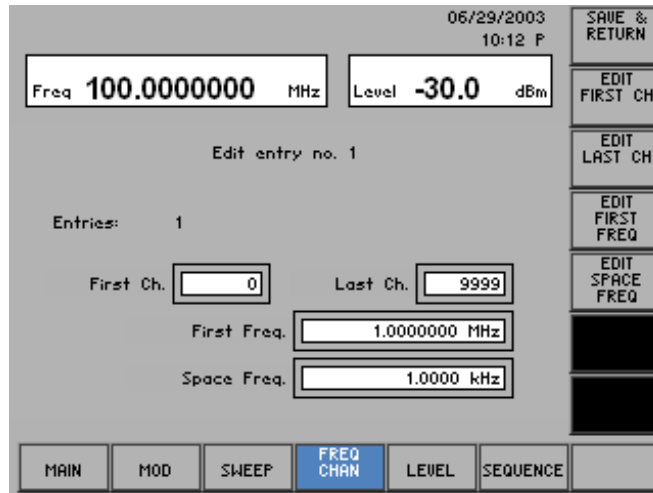

Selecting the entry menu

- Press the **INSERT** or **EDIT** function key in the list menu.

The entry menu is opened and the respective functions are assigned to the function keys [13], for example:



Function key assignment

	Saving a setting and quitting the entry menu	
	Entering a number for the first channel	(↗ below)
	Entering a number for the last channel	(↗ below)
	Entering a frequency value for the first channel	(↗ below)
	Entering a space frequency between the channels	(↗ below)

Entering a number
for the first channel

1. Press the  function key in the entry menu.

An entry field containing the current (EDIT) or an available (INSERT) setting is displayed.



2. Enter a new value (↗ 5-58).
The entry range for the first channel number is:

$$0 \leq \text{First Ch.} \leq 9999$$

The new start number is displayed in the parameter field, e.g. "0".

Entering a number
for the last channel

3. Press the  function key in the entry menu.

An entry field containing the current setting is displayed. The default setting is 9999.



4. Enter a new value (↗ 5-58).
The entry range for the last channel number is:

$$\text{First Ch.} \leq \text{Last Ch.} \leq 9999$$

The new end number is displayed in the parameter field, e.g. "124".

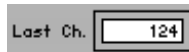
Entering a
frequency value for
the first channel

5. Press the  function key in the entry menu.

An entry field containing the current setting is displayed. The default setting is 1 MHz.

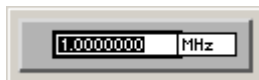

6. Enter a new value in 0.1 Hz steps (↗ 5-58).
The entry range for the start frequency is:

$$9 \text{ kHz} \leq \text{First Freq.} \leq 3 \text{ GHz}$$

The new start frequency is displayed in the parameter field, e.g. "890 MHz".

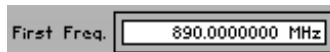

Entering a space frequency between the channels

- Press the  function key in the entry menu.

An entry field containing the current setting is displayed. The default setting is 1 kHz.



- Enter a new value in 0.1 Hz steps (↗ 5-58).
The space frequency entry range is:

0 Hz ≤ Space Freq. ≤ 1 GHz

The new space frequency is displayed in the parameter field, e.g. "200 kHz".



Quitting the entry menu

- Press the  function key in the entry menu.

The new setting is saved. The entry menu is quit, and the R&S SM300 returns to the list menu (↗ 6-122).

NOTE: If the channel numbers have been used previously, the message "Overlapping channel ranges" appears. Please confirm with **ENTER key** [5] and repeat the input of the channel range. (↗ 6-126).

The new/edited list entry is inserted in the channel list.

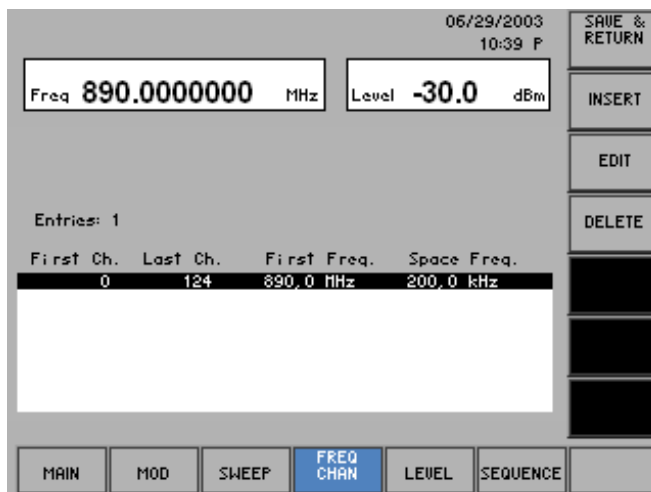

The current list entry contains 124 channels. The first channel has the frequency value of 890 MHz, the second the frequency value of 890.2 MHz, and the third the frequency value of 890.4 MHz, etc. The frequency value of 914.8 MHz is in the last channel.

Quitting the list menu

1. Press the  **function key** in the **list menu**.

An entry field for entering a file name is displayed. The default setting is "user saved" (NEW LIST) or a given file name (VIEW/EDIT LIST).



2. Enter a new file name from the **numerical keys** [12] or from an external keyboard (↵ 3-44).
3. Press the **ENTER key** [5].

The current setting is saved by the file name, the date and time.



Deleting a List Entry

Use

The DELETE function is used to delete individual list entries. The number of entries to be deleted can be set individually, starting from the position of the marker.

List entries are deleted in the line delete menu.

Selecting a list entry

1. Select the list menu (↗ 6-122).
2. In the list menu, select a setting with the ▲ or ▼ **cursor key** [7].
The current selection is highlighted.

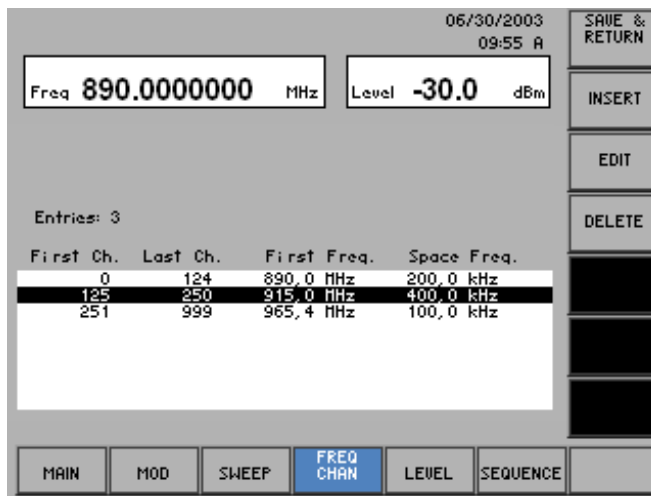

Selecting the line delete menu

3. Press the **DELETE** function key in the list menu.

The line delete menu is opened and the respective functions are assigned to the function keys [13], for example:

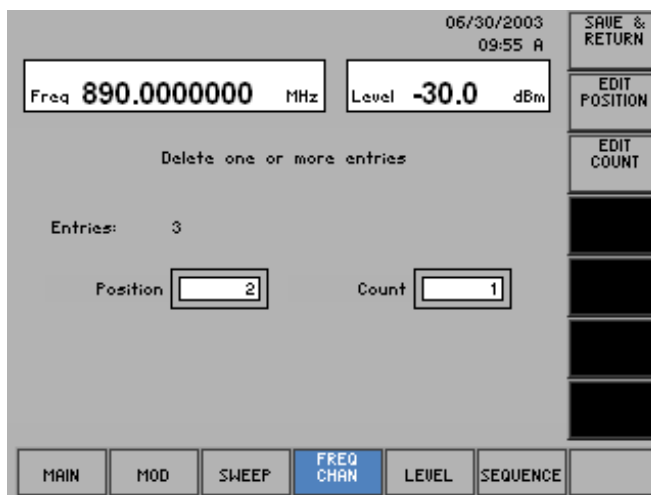

Function key assignment



Saving a setting and quitting the line delete menu



Entering the line number of the list entry to be deleted (↗ below)



Entering the number of list entries to be deleted (↗ below)

Entering the line number of the list entry to be deleted

1. Press the  function key in the line delete menu.
An entry field containing the current setting is displayed.



2. Enter a new value (↵ 5-58).
The entry range for the line number depends on the number of current list entries.
3. Press the **ENTER** key [5].
The new setting is saved and displayed in the parameter field.



Entering the number of list entries to be deleted

4. Press the  function key in the line delete menu.
An entry field containing the current setting is displayed. The default setting is 1.



5. Enter a new value, e.g. "2" (↵ 5-58).
The entry range for the number depends on the current list entries.
6. Press the **ENTER** key [5].
The new setting is saved and displayed in the parameter field.



Deleting list entries and quitting the line delete menu

7. Press the  function key in the line delete menu.
The new setting is saved. The line delete menu is quit, and the R&S SM300 returns to the list menu (↵ 6-122).
List entries are irrevocably deleted without a query and blanked in the channel list.

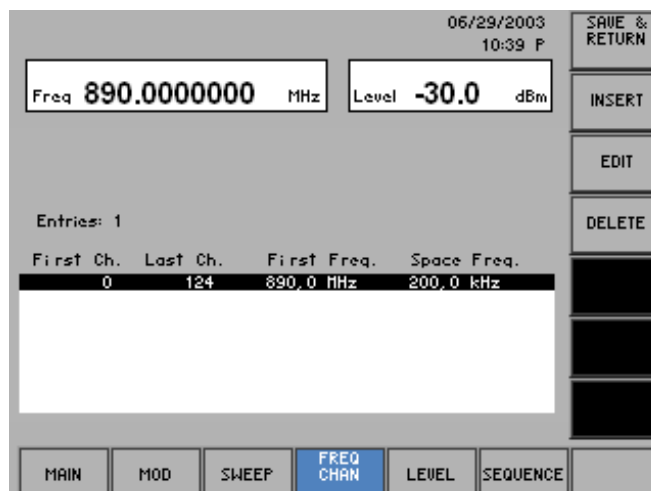

Quitting the list menu

- Press the  function key in the list menu.

The current setting is saved by the file name, the date and time (↗ 6-128).

6.2.4.3.2 Deleting a Channel List

Use

The DELETE LIST function is used to delete a selected channel list. This is necessary if six lists already exist and another one is to be created.

Deleting a list

- Press the  function key in the  submenu.

A selection list containing the stored lists is displayed.

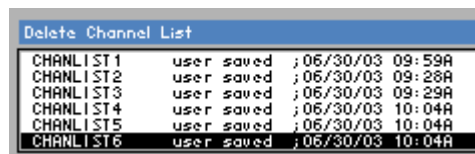

Delete Channel List			
CHANLIST1	user saved	;06/30/03	09:59A
CHANLIST2	user saved	;06/30/03	09:28A
CHANLIST3	user saved	;06/30/03	09:29A
CHANLIST4	user saved	;06/30/03	10:04A
CHANLIST5	user saved	;06/30/03	10:04A
CHANLIST6	user saved	;06/30/03	10:04A

- Select a list with the rotary knob [11].
- Press the **ENTER** key [5] to close the selection field.

A text window is opened where you are asked whether the list should be deleted.



- Press the **ENTER** key [5] to delete the list.





The text window is closed and the selected list deleted.

If you do not wish to delete the list, press the **ESC/CANCEL** key [4].

6.2.4.4 Calling the RF Output Frequency from the Channel List



Use Specific RF output frequencies which you previously entered in channel lists (↗ 6-120), can be set quickly and directly. To do this, you must select the respective channel list and call the frequency value via the channel number.

Selecting a channel list

1. Press the  **function key** in the  **menu**.
2. Press the  **function key** in the  **submenu**.

A selection list containing stored channel lists is displayed. The default setting is "no list".



3. Select a channel list with the **▲** or **▼** **cursor key** [7].
4. Press the **ENTER** key [5] to close the selection field.
The new setting is saved.
5. Press the  **function key** in the  **submenu**.

The submenu is quit, and the current list is displayed in the parameter field.

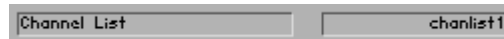

Calling a channel number

1. Press the  **function key** in the  **menu**.

A selection field containing the available settings is displayed.



2. Select a setting with the **rotary knob** [11].
The current frequency value changes according to the assignment in the channel list.
3. Press the **ENTER** key [5] to close the selection field.
The current channel number is displayed in the parameter field, e. g.:



The current frequency value appears in the display area, e. g.:

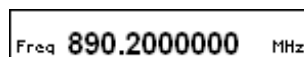

NOTE

If a new frequency is set (↗ 6-74) which does not exactly match a channel frequency, "<none>." is displayed in the parameter field.



6.2.4.5 Holding the Current Frequency Setting

Use

When loading instrument settings (➤ 6-79), the stored RF output frequency value is normally loaded along with the respective instrument setting. However, if you wish to continue using the current frequency setting, you can also load the desired instrument setting without the frequency value.

Holding the current RF output frequency

1. Press the  **function key** in the  **menu**.

The function key is highlighted. When loading instrument settings, the stored frequency setting is not loaded. The current frequency setting is retained.

Overwriting the current RF output frequency

2. Press the  **function key** in the  **menu**.

The function key is **no longer** highlighted, and when loading instrument settings the stored frequency setting is also loaded.

6.2.5 Special Level Settings (LEVEL Menu)

What the settings are for

In the LEVEL menu, you can make settings that affect the level of the output signal. The settings include the entry of a fixed level offset, the choice of a step size for the RF level setting via the rotary knob, the conversion of the level display and the definition of correction lists. In addition, you can define in the menu whether the current level settings are to be overwritten when loading new settings.

Selecting the LEVEL menu

- Select the **LEVEL** menu using the ◀ or ▶ cursor key [6].

The menu name is highlighted and the appropriate functions are assigned to the function keys [13].

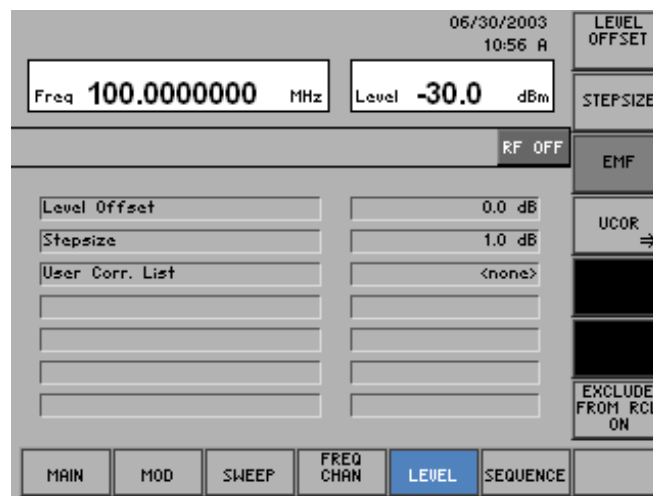

Function key assignment

LEVEL OFFSET	Entering the signal generator level offset	(↗ 6-135)
STEP SIZE	Setting the step size for level entry with the rotary knob	(↗ 6-136)
EMF	Converting the level/voltage display	(↗ 6-136)
UCOR →	Open submenu: Switching manual level correction on, entering correction lists	(↗ 6-137)

NOTE

The **EMF** function key is only available if the unit dBmV, dBμV or mV for the level display has been set (↗ 6-74).

6.2.5.1 Entering the Signal Generator Level Offset

Use If you have connected external attenuators or amplifiers between the RF output and the DUT, you can enter a level offset to adjust the level display. The level offset is added to the output level.

NOTE Entering an offset does not change the RF output signal but only the displayed level value.

Entering the RF level offset

1. Press the  function key in the  menu.

An entry field containing the current setting is displayed. The default setting is 0 dB.



2. Enter a new value in 0.1 dB steps (↗ 5-58).
The level entry range is:

$$-100 \text{ dB} \leq \text{Level Offset} \leq +100 \text{ dB}$$

The new setting is saved and displayed in the parameter field, e.g. 10 dB.



The displayed level value increases with a positive offset and decreases with a negative offset. A positive offset corresponds to an amplification of the signal, while a negative offset means a weakening of the signal.

Lev-Offs is displayed in the status line.



The level that was set as the RF output level is applied to the signal generator output (↗ 6-74).

6.2.5.2 Setting the Step Size for Level Entry With the Rotary Knob

Use When you enter the level using the cursor keys and the rotary knob, the value is increased or decreased in steps of a size that you can specify. This can be set as desired, increasing or decreasing the level value by the set increment.

Setting the step size

1. Press the **STEP SIZE** function key in the **LEVEL** menu.

An entry field containing the current setting is displayed. The default setting is 1 dB.



2. Enter a new value in 0.1 dB steps (↵ 5-58).
The entry range for the step size is:

$$0.1 \text{ dB} \leq \text{Level Step Size} \leq 100 \text{ dB}$$

The new setting is saved and displayed in the parameter field.

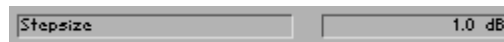

6.2.5.3 Converting the Level/Voltage Display

NOTE

The **EMF** function key is only available if the unit dBmV, dBμV or mV for the level display has been set (↵ 6-74).

Use

The level or voltage display is normally with reference to the output load 50 Ω (adjustment, normal display). If you have selected the unit dBmV, dBμV or mV, you can also have the level or voltage displayed without output load (open circuit).

Displaying the open-circuit voltage

1. For the level, select the units dBmV, dBμV or mV from (↵ 6-74), e. g.:

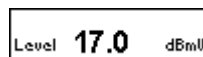

2. Press the **EMF** function key in the **LEVEL** menu.

The function key is highlighted, and the output level is displayed as an open-circuit voltage, with "EMF" shown in the display field.

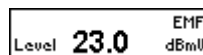

Displaying the normal level

3. Press the **EMF** function key in the **LEVEL** menu.

The function key is **no longer** highlighted, and the output level is displayed with reference to the output load 50 Ω (adjustment, normal display). "EMF" is blanked from the level display.

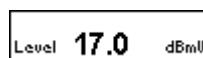

6.2.5.4 Manual Level Correction

What the settings are for

A correction list can be created in order to take the frequency response of external components (attenuators, jumpers, DC block, etc) into account in the R&S SM300's level display. The level at the RF output is corrected by the entered list value at the reference points. The correction value between the two frequency reference points entered is linearly interpolated. A positive correction value raises the output level, while a negative value lowers it.





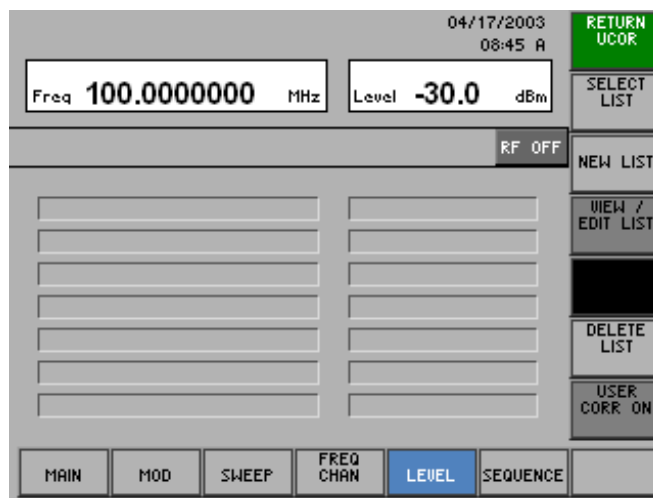

Selecting the UCOR submenu

- Press the  function key in the  menu.



The submenu is opened and the respective functions are assigned to the function keys [13].



Function key assignment

	Quitting the submenu	
	Selecting a correction list	(↗ 6-138, 6-147)
	Creating a new correction list	(↗ 6-138)
	Viewing/editing a correction list	(↗ 6-138)
	Deleting a correction list	(↗ 6-146)
	Switching a correction list on/off	(↗ 6-147)

NOTE

The function keys  and  are only available if a correction list has been selected (↗ 6-138, 6-147).

The  function key is only available if fewer than 6 channel lists have been saved. To create a new list, another one must be deleted.

6.2.5.4.1 Creating/Editing a Correction List

Use In the UCOR submenu, you can create new correction lists or select and edit existing ones.

For frequencies not included in the correction list, level correction values are determined by interpolation based on the nearest correction values.

Menu structure for list entry

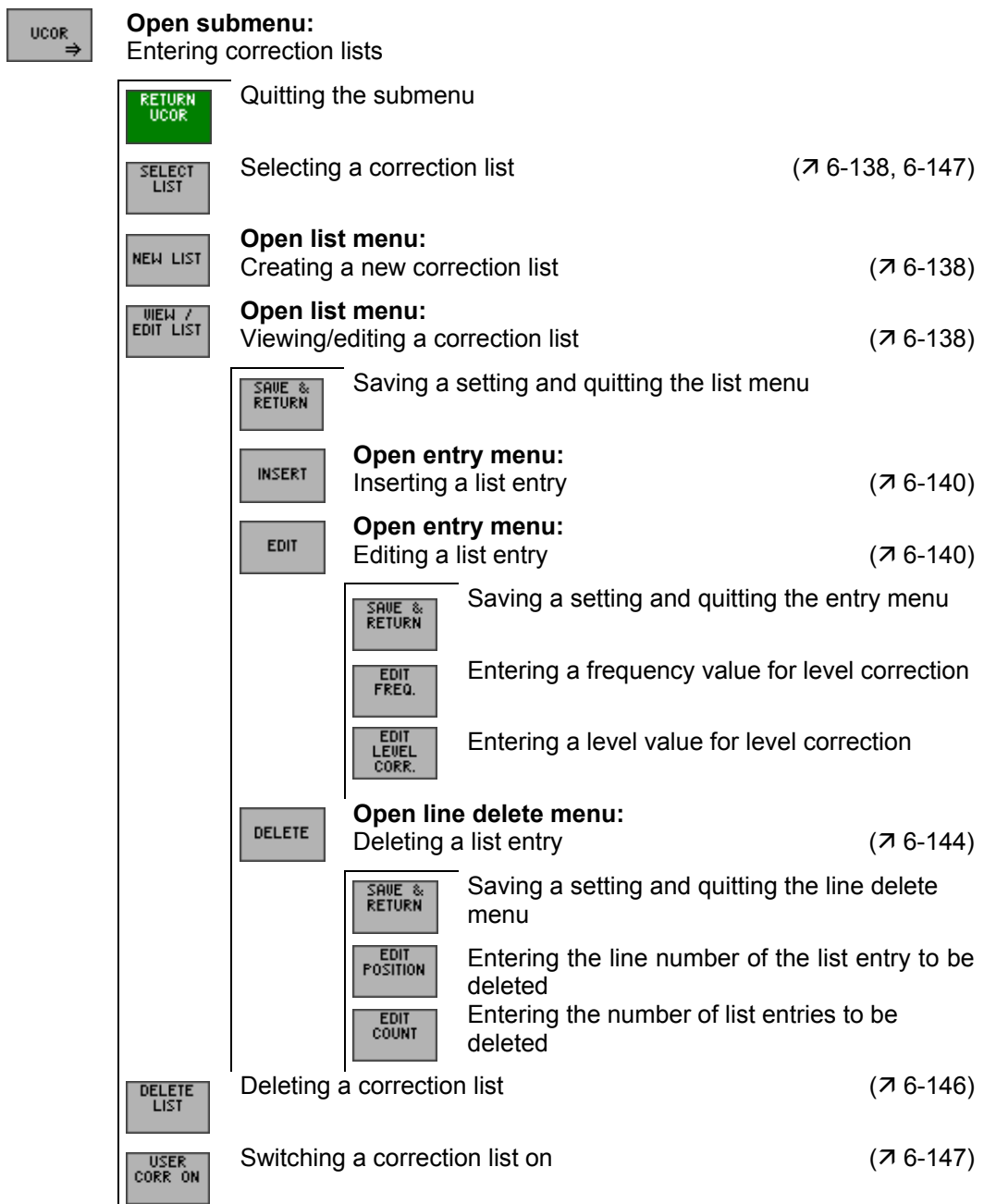

Creating a new correction list

- Press the **NEW LIST** function key in the **UCOR** submenu. This takes you directly to the entry menu, where you can insert a list entry (↗ 6-140). After you complete the first entry, the list menu appears, where you can further edit the correction list (↗ below, "Editing a list entry").
- NOTE:** If 6 lists already exist, the message "No more user correction list can be created" will appear and a channel list has to be deleted first (↗ 6-146).

Selecting a correction list

1. Press the **SELECT LIST** function key in the **UCOR** submenu. A selection list containing stored correction lists is displayed.

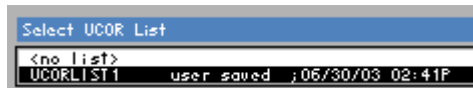



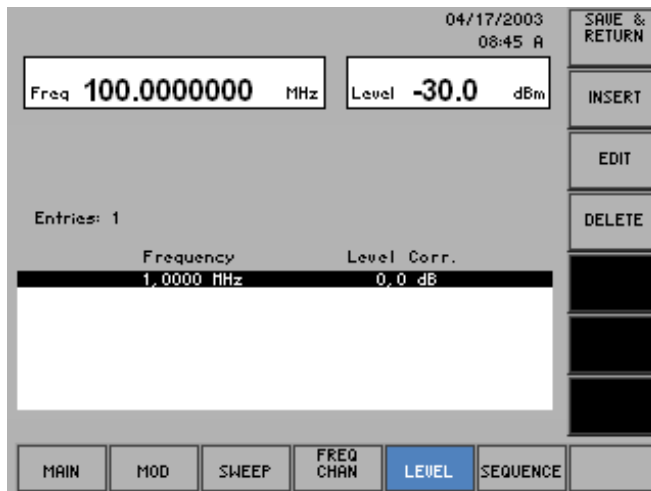

2. Select a correction list with the **▲** or **▼** cursor key [7].
3. Press the **ENTER** key [5] to close the selection field. The new setting is saved.

Editing a list entry



4. Press the **VIEW / EDIT LIST** function key in the **UCOR** submenu. The list menu containing the current correction list opens and the function keys [13] are assigned the appropriate functions.



Function key assignment

	Saving a setting and quitting the list menu	
	Inserting a list entry	(↗ 6-140)
	Editing a list entry	(↗ 6-140)
	Deleting a list entry	(↗ 6-144)

NOTE

The  and  function keys are only available if a list entry exists.

Inserting/Editing a List Entry

Use In the list submenu, correction values can be entered and edited.
The parameters of a list entry are entered in the entry menu.

- Selecting a list entry**
1. Select the list menu (↗ 6-138).
 2. Select a list entry with the ▲ or ▼ **cursor key** [7].

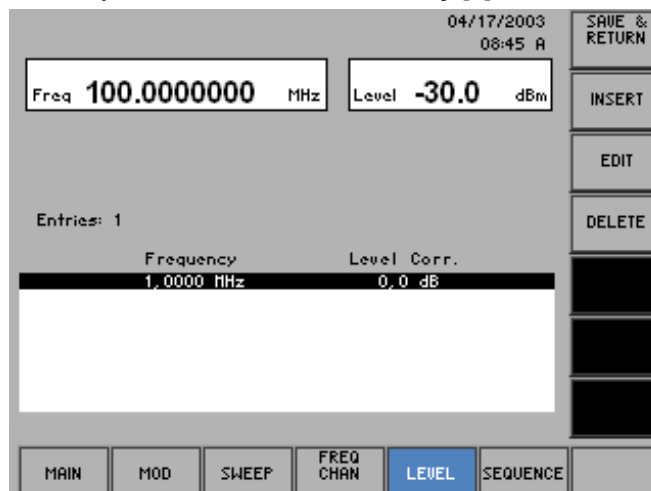

The list entry can either be edited (EDIT) or it serves to mark the position for new subsequent list entries (INSERT).

Selecting the entry menu

3. Press the **INSERT** or **EDIT** function key in the list menu.

The entry menu is opened and the respective functions are assigned to the function keys [13], for example:

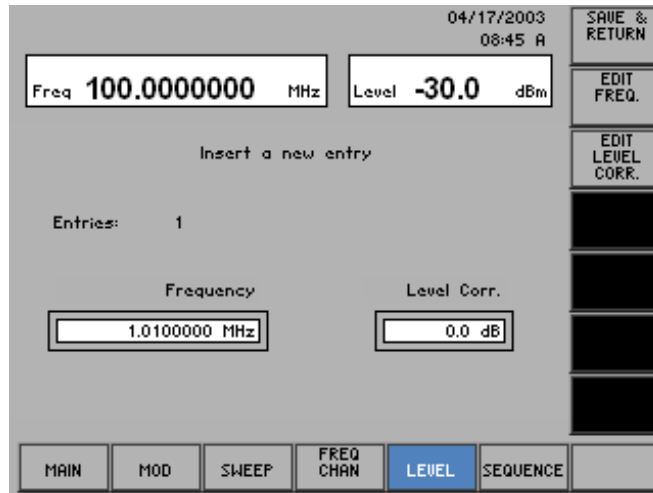

Function key assignment

SAVE & RETURN	Saving a setting and quitting the entry menu	
EDIT FREQ.	Entering a frequency value for level correction	(↗ below)
EDIT LEVEL CORR.	Entering a level value for level correction	(↗ below)

Entering a frequency value for level correction

1. Press the  function key in the entry menu.

An entry field containing the current (EDIT) or an available (INSERT) setting is displayed, for example:

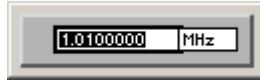

2. Enter a new value (↗ 5-58).
The frequency entry range is:

$$9 \text{ kHz} \leq \text{Frequency} \leq 3 \text{ GHz}$$

The new frequency value is displayed in the parameter field, e. g.:

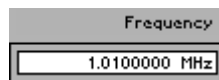

Entering a level value for level correction

3. Press the  function key in the entry menu.

An entry field containing the current setting is displayed. The default setting is 0 dB.



4. Enter a new value, e. g. 10 (↗ 5-58).
The entry range for the end number is:

$$0 \text{ dB} \leq \text{Level Corr.} \leq -100 \text{ dB}$$

The new end number is saved and displayed in the parameter field, e. g.:

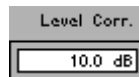

Quitting the entry menu

5. Press the  function key in the entry menu.

The new setting is saved. The entry menu is quit, and the R&S SM300 returns to the list menu (➔ 6-138).

NOTE: If you want overwrite a saved frequency value with a new correction value the message „Do you want to owerwrite freq 1.000 MHz?“ appears. Confirm with the **ENTER key** [5] or cancel the procedure with the **ESC/CANCEL key** [4].

The new/edited list entry is inserted in the correction list.

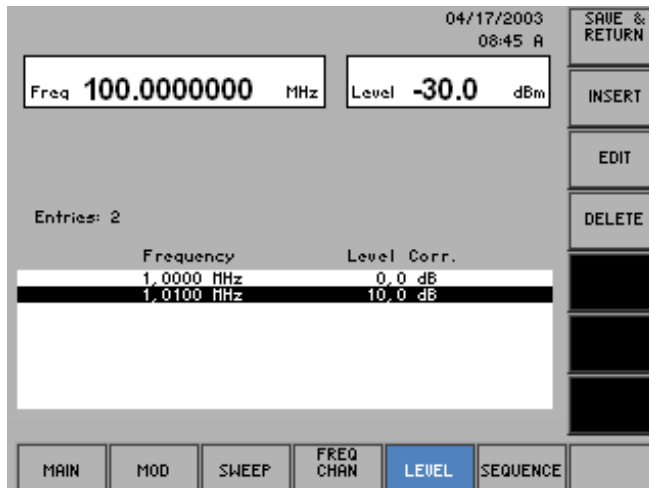

Quitting the list menu

1. Press the  function key in the list menu.

An entry field for entering a file name is displayed. The default setting is “user saved” (NEW LIST) or a given file name (VIEW/EDIT LIST).



2. Enter a new file name from the **numerical keys** [12] or from an external keyboard (➔ 3-44).
3. Press the **ENTER key** [5].

The current setting is saved by the file name, the date and time.



Deleting a List Entry

Use

The DELETE function is used to delete individual list entries. The number of entries to be deleted can be set individually, starting from the position of the marker.

List entries are deleted in the line delete menu.

Selecting a list entry

1. Select the list menu (↗ 6-138).
2. In the list menu, select a setting with the ▲ or ▼ **cursor key** [7].
The current selection is highlighted.

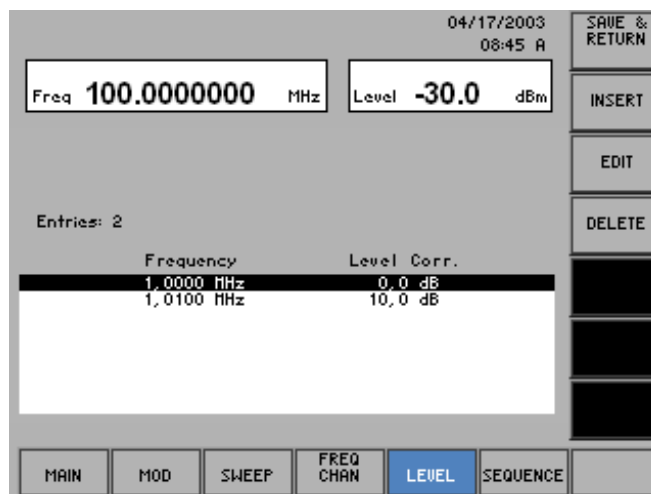

Selecting the line delete menu

3. Press the **DELETE** function key in the list menu.

The line delete menu is opened and the respective functions are assigned to the function keys [13], for example:

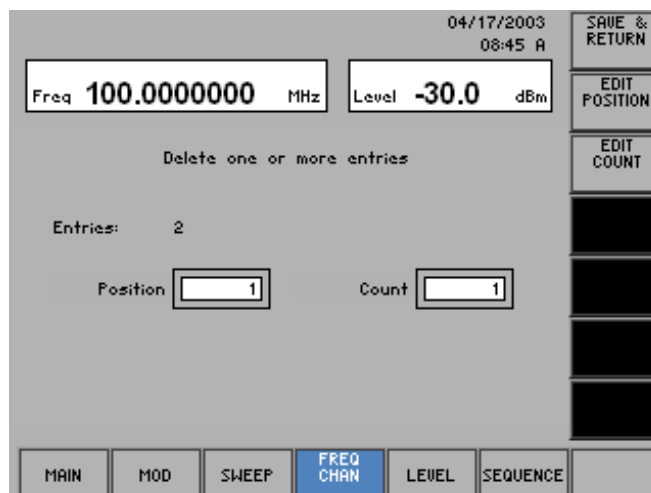

Function key assignment



Saving a setting and quitting the line delete menu



Entering the line number of the list entry to be deleted (↗ below)



Entering the number of list entries to be deleted (↗ below)

Entering the line number of the list entry to be deleted

1. Press the  function key in the line delete menu.
An entry field containing the current setting is displayed.



2. Enter a new value. (↗ 5-58).
The entry range for the line number depends on the number of current list entries.
3. Press the **ENTER** key [5].
The new setting is saved and displayed in the parameter field.

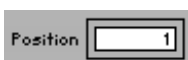

Entering the number of list entries to be deleted

4. Press the  function key in the line delete menu.
An entry field containing the current setting is displayed. The default setting is 1.



5. Enter a new value. (↗ 5-58).
The entry range for the number depends on the current list entries.
6. Press the **ENTER** key [5].
The new setting is saved and displayed in the parameter field.



Quitting the line delete menu

7. Press the  function key in the line delete menu.
The new setting is saved. The line delete menu is quit, and the R&S SM300 returns to the list menu (↗ 6-138).
List entries are irrevocably deleted without a query and blanked in the correction list.

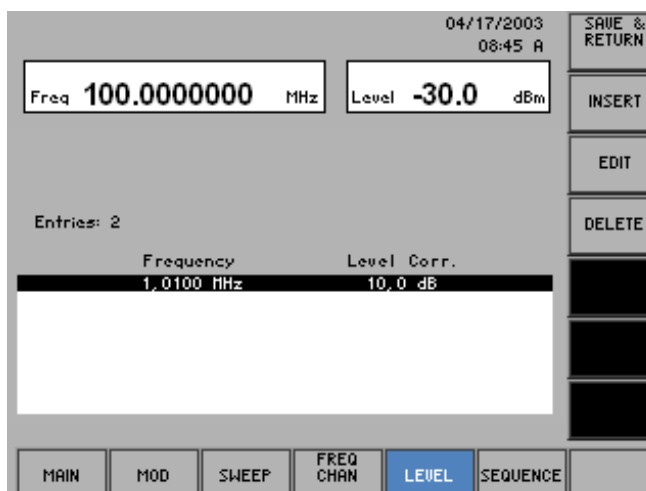

Quitting the list menu

- Press the  function key in the list menu.

The current setting is saved by the file name, the date and time (↗ 6-143).

6.2.5.4.2 Deleting a Correction List

Use

The DELETE LIST function is used to delete a selected correction list. This is necessary if six lists already exist and another one is to be created.

Deleting a list

- Press the  function key in the  submenu.

A selection list containing the stored lists is displayed.

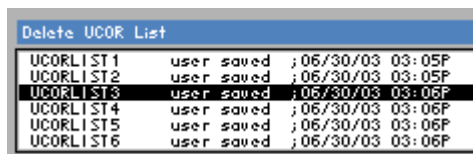

Delete UCOR List			
UCORLIST1	user saved	; 06/30/03	03:05P
UCORLIST2	user saved	; 06/30/03	03:05P
UCORLIST3	user saved	; 06/30/03	03:06P
UCORLIST4	user saved	; 06/30/03	03:06P
UCORLIST5	user saved	; 06/30/03	03:06P
UCORLIST6	user saved	; 06/30/03	03:06P

- Select a list with the rotary knob [11].
- Press the **ENTER** key [5] to close the selection field.

A text window is opened where you are asked whether the list should be deleted.

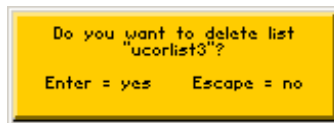

- Press the **ENTER** key [5] to delete the list.

The text window is closed and the selected list deleted.

If you do not wish to delete the list, press the **ESC/CANCEL** key [4].

6.2.5.4.3 Switching Manual Level Correction On

Use

After selecting a correction list, you can switch manual level correction on.

Selecting a correction list

1. Press the  **function key** in the  **submenu**.

A selection list containing stored correction lists is displayed. The default setting is "no list".



2. Select a correction list with the \blacktriangle or \blacktriangledown **cursor key** [7].
3. Press the **ENTER key** [5] to close the selection field.
The new setting is saved.

Switching manual level correction on

4. Press the  **function key** in the  **submenu**.

The function key is highlighted. The new setting is stored, and the level correction value (UCorr) and current output level (Level) are displayed, e.g.:

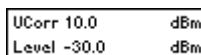

"UCORR" is displayed in the status line.



Switching manual level correction off

5. Press the  **function key** in the  **submenu**.

The function key is **no longer** highlighted. The new setting is stored, and the current output level is displayed.

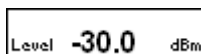

"UCORR" is blanked in the status line.

NOTE

The level applied to the R&S SM300's RF output is the sum of the displayed values for LEVEL and UCORR.

6.2.6 User-Defined Sequences of Settings (SEQUENCE Menu)

What the settings are for

In the SEQUENCE menu, you can generate and start user-defined sequences of settings. This involves saving instrument settings, creating sequence lists from instrument settings and controlling sequence lists.

Selecting the SEQUENCE menu

- Select the **SEQUENCE** menu using the ◀ or ▶ **cursor key** [6].

The menu name is highlighted and the appropriate functions are assigned to the function keys [13].

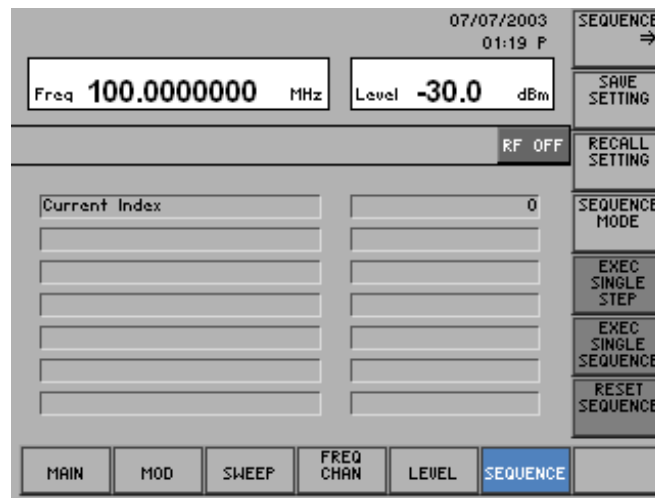

Function key assignment

	Open submenu: Creating a sequence	(↗ 6-151)
	Saving instrument settings	(↗ 6-149)
	Loading instrument settings	(↗ 6-149)
	Setting the sequence mode	(↗ 6-161)
	Performing the sequence mode step by step	(↗ 6-161)
	Starting a single sequence	(↗ 6-161)
	Resetting an ongoing sequence	(↗ 6-161)

NOTE

The , and function keys are only available if sequencing was switched on (↗ 6-161).

6.2.6.1 Saving and Loading User-Defined Settings

Use

The R&S SM300 offers you the possibility to save and load user-defined instrument settings, which allows you to use the signal generator for certain repetitive tasks.

You can save 16 different instrument settings (SAVE 1-16). When the R&S SM300 is delivered, the factory settings are loaded in the SAVE memory locations.

Furthermore, you can combine and arrange the different instrument settings as desired and start them as an application (output signal with different settings) (↗ 6-151).

Saving a user-defined setting

1. Set the R&S SM300 to suit the task at hand (output signal) (↗ 6-73).
2. Press the **SAVE SETTING** function key in the **SEQUENCE** menu.

A table containing the available and/or stored settings is displayed (memory locations).

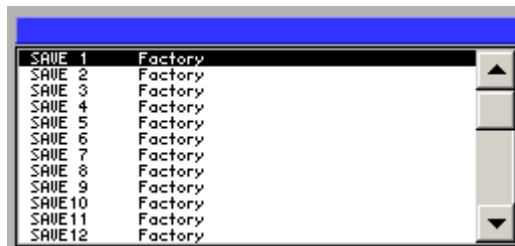

SAVE 1	Factory
SAVE 2	Factory
SAVE 3	Factory
SAVE 4	Factory
SAVE 5	Factory
SAVE 6	Factory
SAVE 7	Factory
SAVE 8	Factory
SAVE 9	Factory
SAVE 10	Factory
SAVE 11	Factory
SAVE 12	Factory

3. Select a setting with the **▲** or **▼** cursor key [7].
The current selection is highlighted.
4. Press the **ENTER** key [5].
An entry field for entering a file name is displayed. The default setting is "user saved".



5. Enter a new file name from the **numerical keypad** [12] or from an external keyboard (↗ 3-44).
6. Press the **ENTER** key [5].
The current setting is saved and the text "Factory" is replaced by the file name, the date and time.



SAVE 1	user saved :11/26/02 11:57A
SAVE 2	Factory
SAVE 3	Factory
SAVE 4	Factory
SAVE 5	Factory
SAVE 6	Factory
SAVE 7	Factory
SAVE 8	Factory
SAVE 9	Factory
SAVE 10	Factory
SAVE 11	Factory
SAVE 12	Factory

Loading a user-defined setting

1. Press the **RECALL SETTING** function key in the **SEQUENCE** menu.

A table containing the available settings is displayed (memory locations).



SAVE	Value
SAVE 1	user saved :11/26/02 11:57A
SAVE 2	Factory
SAVE 3	Factory
SAVE 4	Factory
SAVE 5	Factory
SAVE 6	Factory
SAVE 7	Factory
SAVE 8	Factory
SAVE 9	Factory
SAVE 10	Factory
SAVE 11	Factory
SAVE 12	Factory

2. Select a setting with the **▲** or **▼** cursor key [7].
The FACTORY memory location contains the factory setting (↗ 6-71).
3. Press the **ENTER** key [5].
The selected instrument setting is loaded.

6.2.6.2 Creating a Sequence

What the settings are for

The R&S SM300 offers you the possibility to enter stored instrument settings in sequence lists. In the SEQUENCE submenu, you can create new sequence lists, and edit or delete stored sequence lists.

Six lists can be created.



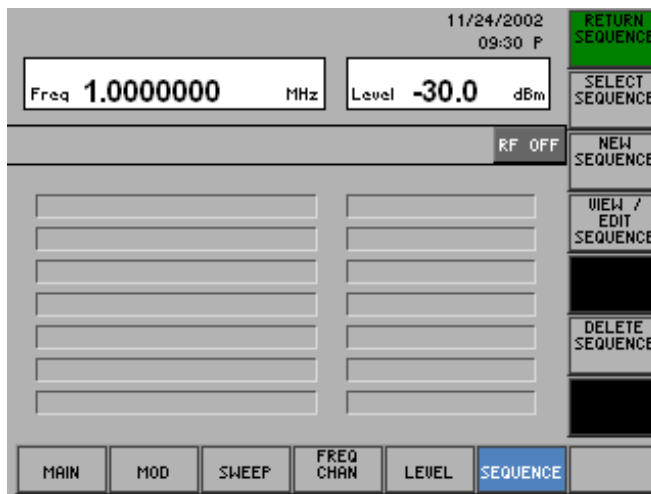

Selecting the SEQUENCE submenu

- Press the  function key in the  menu.

The submenu is opened and the respective functions are assigned to the function keys [13].



Function key assignment

	Quitting the submenu	
	Selecting a sequence list	(↗ 6-152), (↗ 6-161)
	Creating a new sequence list	(↗ 6-152)
	Viewing/editing a sequence list	(↗ 6-152)
	Deleting a sequence list	(↗ 6-160)

NOTE

The  function key is only available if a sequence list was selected. (↗ 6-161).

The  function key is only available if fewer than 6 sequence lists have been saved. To create a new list, another one must be deleted.

6.2.6.2.1 Creating/Editing a sequence List

Use Test sequences can be automated with the aid of sequence lists. In the SEQUENCE submenu, different instrument settings that have been saved can be sequentially processed at the simple stroke of a key.

Menu structure for list entry

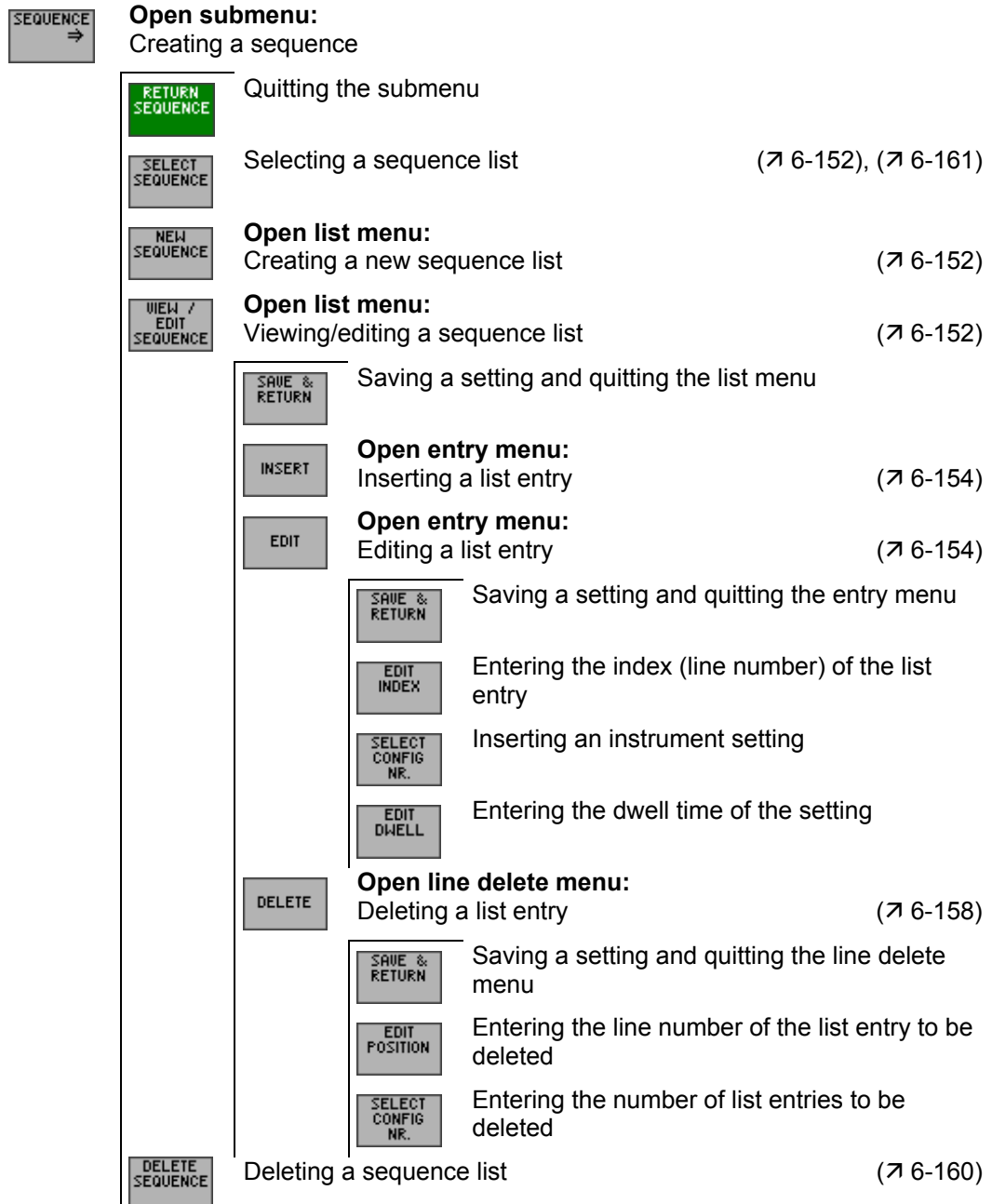

Creating a new sequence list

- Press the **NEW SEQUENCE** function key in the **SEQUENCE** submenu.

This takes you directly to the entry menu, where you can insert a list entry (↗ 6-154).

After you complete the first entry, the list menu appears, where you can further edit the sequence list (↗ below, "Editing a list entry").

NOTE: If 6 lists already exist, the message "No more sequence can be created" will appear and a channel list has to be deleted first (↗ 6-160).

Selecting a sequence list

- Press the **SELECT SEQUENCE** function key in the **SEQUENCE** submenu.

A selection list containing stored sequence lists is displayed.

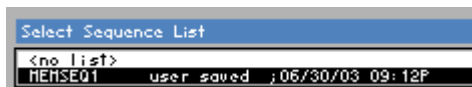

- Select a sequence list with the **▲** or **▼** cursor key [7].
- Press the **ENTER** key [5] to close the selection field. The new setting is saved.



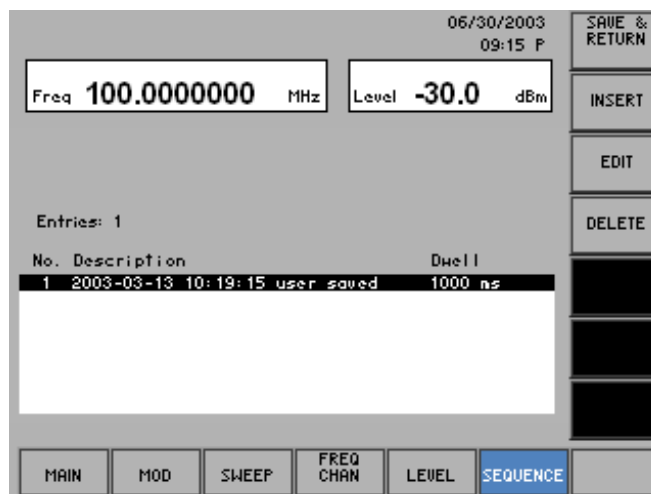

Editing a list entry

- Press the **VIEW / EDIT SEQUENCE** function key in the **SEQUENCE** submenu.

The list menu containing the current sequence list opens and the function keys [13] are assigned the appropriate functions.



Function key assignment

	Saving a setting and quitting the list menu	
	Inserting a list entry	(↗ 6-154)
	Editing a list entry	(↗ 6-154)
	Deleting a list entry	(↗ 6-158)

NOTE The  and  function keys are only available if a list entry exists.

Inserting/Editing a List Entry

Use In the list submenu, you can call any stored instrument setting as a list entry and arrange it in any order you like. In addition, for each setting you can define a dwell time during which the setting should be applied to the RF output.

The parameters of a list entry are entered in the entry menu.

Selecting a list entry

1. Select the list menu (↗ 6-152).
2. Select a list entry with the ▲ or ▼ **cursor key** [7].

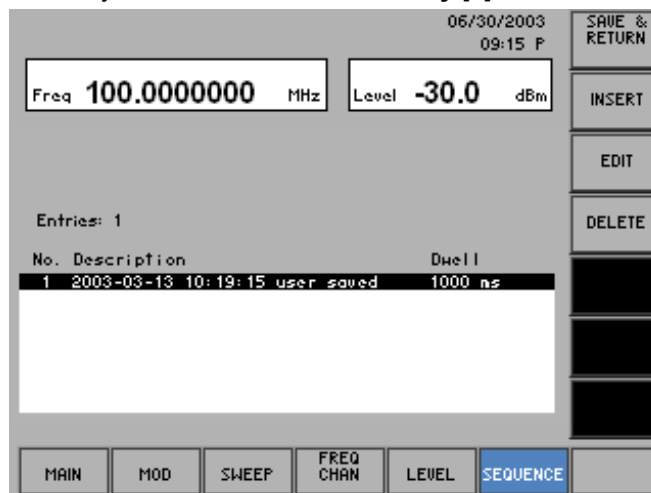

The list entry can either be edited (EDIT) or it serves to mark the position for new subsequent list entries (INSERT).



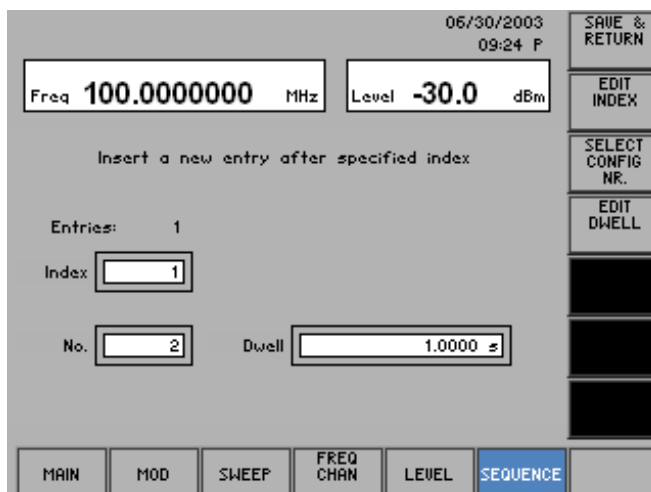

Selecting the entry menu

- Press the **INSERT** or **EDIT** function key in the list menu

The entry menu is opened and the respective functions are assigned to the function keys [13], for example:



Function key assignment

	Saving a setting and quitting the entry menu	
	Entering the index (line number) of the list entry	(↗ below)
	Selecting an instrument setting	(↗ below)
	Instrument setting dwell time	(↗ below)

NOTE

Pressing the **NEW SEQUENCE** function key in the **SEQUENCE** submenu takes you directly to the entry menu. With the first list entry, the **EDIT INDEX** function key is not yet available.

Entering the index
(line number) of the
list entry

1. Press the  function key in the entry menu.

An entry field containing the current (EDIT) or an available (INSERT) setting is displayed, for example:



2. Enter a new value (↗ 5-58).
The index entry range is:

$$1 \leq \text{Index} \leq \text{Line Number}$$

The index is displayed in the parameter field, e. g.:



Selecting a stored
instrument setting

3. Press the  function key in the entry menu.

A table containing the available instrument settings is displayed (↗ 6-149).

SAVE 1	test	:11/26/02 09:47
SAVE 2	user saved	:11/26/02 11:57
SAVE 3	Factory	
SAVE 4	Factory	
SAVE 5	Factory	
SAVE 6	Factory	
SAVE 7	Factory	
SAVE 8	Factory	
SAVE 9	Factory	
SAVE10	Factory	
SAVE11	Factory	
SAVE12	Factory	

4. Select a setting with the ▲ or ▼ cursor key [7].
The FACTORY memory location contains the factory setting (↗ 6-71).
5. Press the ENTER key [5] to close the table.
The selected instrument setting is entered in the sequence list, and the memory location number is displayed in the parameter field.



Entering the
instrument setting
dwell time

6. Press the  function key in the entry menu.

An entry field containing the current setting is displayed. The default setting is 1 s.

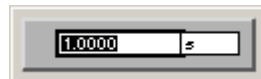

7. Enter a new value in 1 ms steps (↗ 5-58).
The entry range for the dwell time is:

$$100 \text{ ms} \leq \text{Dwell} \leq 1 \text{ s}$$

The new setting is stored, and the time during which the instrument setting is applied to the RF output is displayed in the parameter field.



Quitting the entry menu

- Press the  function key in the entry menu.

The new setting is saved. The entry menu is quit, and the R&S SM300 returns to the list menu (↗ 6-152).

The new/edited list entry is inserted in the sequence list.

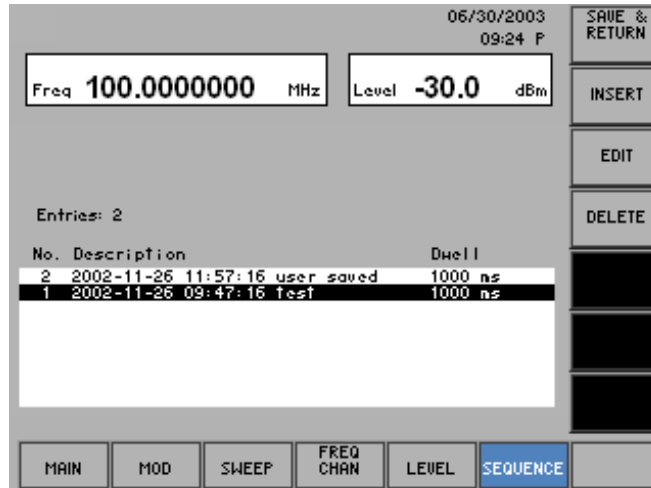

Quitting the list menu

- Press the  function key in the list menu.

An entry field for entering a file name is displayed. The default setting is "user saved" (NEW LIST) or a given file name (VIEW/EDIT LIST).



- Enter a new file name from the **numerical keys** [12] or from an external keyboard (↗ 3-44).
- Press the **ENTER key** [5].

The current setting is saved by the file name, the date and time.



Deleting a List Entry

Use

The DELETE function is used to delete individual list entries. The number of entries to be deleted can be set individually, starting from the position of the marker.

List entries are deleted in the line delete menu.

Selecting a list entry

1. Select the list menu (↗ 6-152).
2. In the list menu, select a setting with the ▲ or ▼ **cursor key** [7].
The current selection is highlighted.

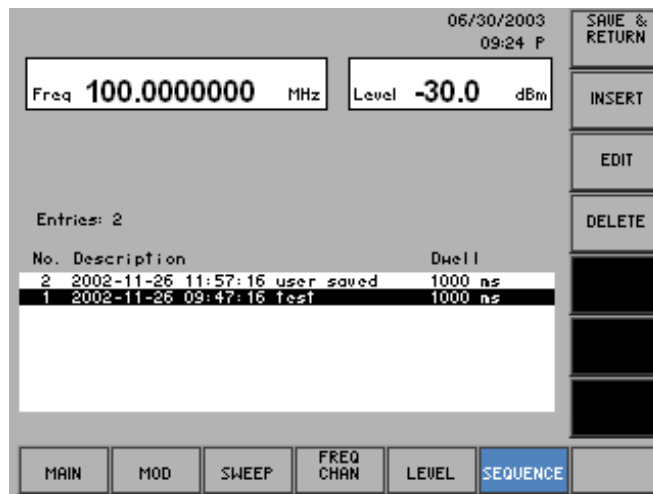

Selecting the line delete menu

3. Press the **DELETE** function key in the list menu.

The line delete menu is opened and the respective functions are assigned to the function keys [13]:

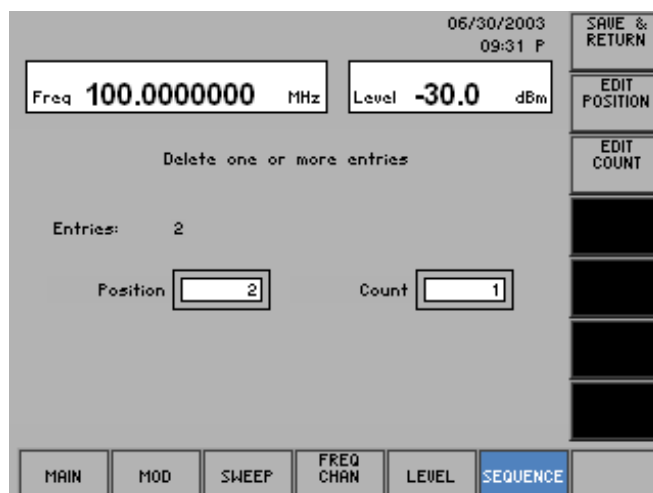

Function key assignment



Saving a setting and quitting the line delete menu



Entering the line number of the list entry to be deleted (↗ below)



Entering the number of list entries to be deleted (↗ below)

Entering the line number of the list entry to be deleted

1. Press the  function key in the line delete menu.
An entry field containing the current setting is displayed. The default setting is 1.



2. Enter a new value (↵ 5-58).
The entry range for the line number depends on the number of current list entries.
3. Press the **ENTER** key [5].
The new setting is saved and displayed in the parameter field.



Entering the number of list entries to be deleted

4. Press the  function key in the line delete menu.
An entry field containing the current setting is displayed. The default setting is 1.



5. Enter a new value, e.g. "2" (↵ 5-58).
The entry range for the number depends on the current list entries.
6. Press the **ENTER** key [5].
The new setting is saved and displayed in the parameter field.



Deleting list entries and quitting the line delete menu

7. Press the  function key in the line delete menu.
The new setting is saved. The line delete menu is quit, and the R&S SM300 returns to the list menu (↵ 6-152).

List entries are irrevocably deleted without a query and blanked in the sequence list.

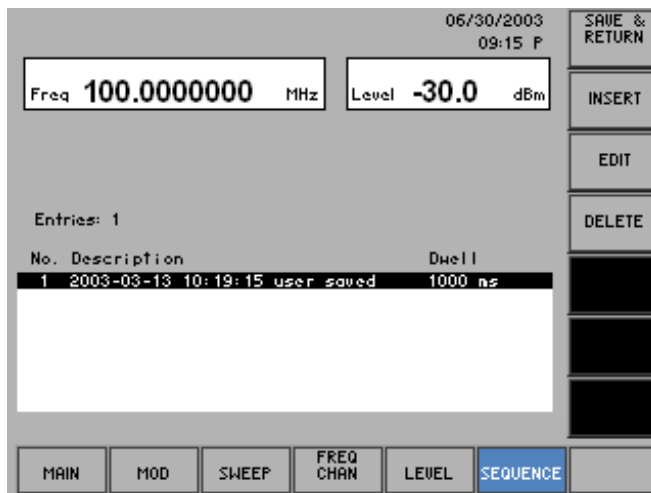

Quitting the list menu

- Press the  function key in the list menu.

The current setting is saved by the file name, the date and time (↗ 6-157).

6.2.6.2.2 Deleting a Sequence List

Use

Altogether six different sequence lists can be created and saved. If you want to create additional lists, first you have to delete old lists.

Deleting a sequence list

- Press the  function key in the  submenu.

A selection list containing the stored lists is displayed.

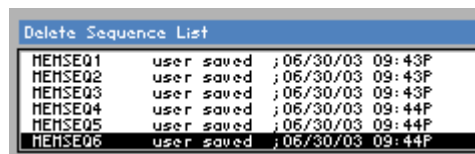

- Select a list with the rotary knob [11].
- Press the **ENTER** key [5] to close the selection field.

A text window is opened where you are asked whether the list should be deleted.



- Press the **ENTER** key [5] to delete the list.

The text window is closed and the selected list deleted.

If you do not wish to delete the list, press the **ESC/CANCEL** key [4].

6.2.6.3 Setting/Starting the Sequence Mode

Use

After compiling a sequence (sequence list) from a number of instrument settings (➤ 6-151), you can start it as an application. The following sequence modes are available:

- **OFF**
The sequence mode is switched off.
- **AUTO**
The sequence is continuously restarted.
- **SINGLE**
The sequence is started manually and stops after a single run.
- **STEP**
The sequence is performed step by step.

Selecting a sequence list

1. Press the  function key in the  submenu.

A selection list containing stored sequence lists is displayed. The default setting is "no list".



2. Select a sequence list with the ▲ or ▼ cursor key [7].
3. Press the **ENTER key** [5] to close the selection field.
The new setting is saved.

Setting/starting the sequence mode

1. Press the  function key in the  submenu.

The submenu is exited.

2. Press the  function key in the  menu.

A selection field containing the available settings is displayed. The default setting is OFF.

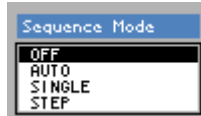

3. Select a setting with the rotary knob [11].
4. Press the ENTER key [5] to close the selection field.
The new setting is saved.

Performing a single sequence

In the SINGLE sequence mode:

- Press the  function key in the  menu.

A single sequence is performed. This procedure can be repeated as often as desired.

Restarting the ongoing sequence

In every sequence mode:

- Press the  function key in the  menu.

The ongoing sequence is interrupted and reset to the current start position. Subsequently the sequence begins anew (except in the SINGLE sequence mode).

Performing the sequence step by step

In the STEP sequence mode:

- Press the  function key in the  menu.

The sequence is performed step by step. After pressing the function key the instrument setting will be loaded from the sequence-list and executed. This procedure can be repeated as often as desired.

Switching the sequence mode off

1. Press the  function key in the  menu.

A selection field containing the available settings is displayed.

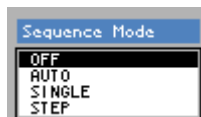

2. Select OFF with rotary knob [11].
3. Press the ENTER key [5] to close the selection field.
The new setting is saved and the sequence is switched off.

6.3 SYSTEM Functions (SYS Key)

Introduction

The R&S SM300 has system and service functions as well as generator functions.

All current settings can be called so that they can be viewed at a glance, and saved for use at a later date, a selftest can be run on the R&S SM300 and the system settings configured. Furthermore, the R&S SM300 can be switched over from remote control to local mode.

Switching over the user interface

When the R&S SM300 has been switched on and the selftest has run without detecting any faults, the signal generators's user interface is activated.

1. Press the **SYS key** [3].

The frequency and level display, the status line and the parameter field are blanked out. The menus for the system and service functions are brought up on the screen in the menu area and the appropriate functions are assigned to the function keys [13]. Depending on the function key assignment, the associated parameters are listed as tables in the diagram area.

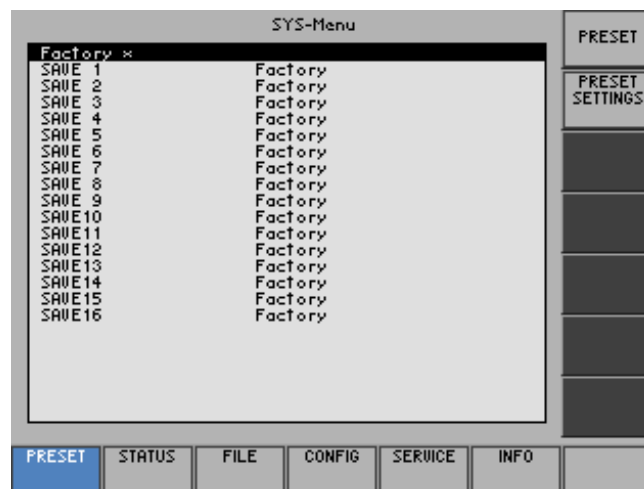







2. Press the **SYS key** [3].

The **new** settings are saved and the signal generators's user interface is activated again.

Press the **ESC/CANCEL key** [4].

The **old** settings are retained and the signal generators's user interface is activated again.

**Menus for
system and
service functions**

	Selects and calls the instrument's default setting	(↗ 6-165)
	Displays the current instrument settings	(↗ 6-167)
	Saves and loads user-defined settings	(↗ 6-168)
	System settings	(↗ 6-174)
	Service functions	(↗ 6-184)
	System information	(↗ 6-185)

6.3.1 Instrument Default Setting (Menu PRESET)

What the settings are for

From the PRESET menu, you can specify a user-defined instrument setting as the instrument default setting and directly call it.

Selecting the PRESET menu

1. Press the **SYS key** [3].
2. Select the menu  with the ◀ or ▶ **cursor key** [6].

The menu name is highlighted and the appropriate functions are assigned to the function keys [13].



Function key assignment



Calls an instrument default setting

(↗ 6-166)



Selects an instrument default setting

(↗ 6-166)

6.3.1.1 Selecting and Calling the Instrument Default Setting

Use

When you switch on the R&S SM300, those settings that were valid when the R&S SM300 was last switched off are restored.

The R&S SM300 also lets you save and call user-defined instrument settings. If you frequently use one of these settings and want to load it quickly, you can define this setting to be the PRESET (default setting) and call it directly at any time.

Selecting user-defined settings

1. Save the user-defined settings (↗ 6-169).
2. Select the menu  with the ◀ or ▶ **cursor key** [6].

A table containing the available settings is displayed. The current setting is marked with the sign x.

FACTORY x	
SAVE 1	Factory
SAVE 2	Factory
SAVE 3	Factory
SAVE 4	Factory
SAVE 5	user saved; 01.09.2002 22:00
SAVE 6	Factory
SAVE 7	Factory
SAVE 8	Factory
SAVE 9	Factory
SAVE10	Factory
SAVE11	Factory

3. Select a setting with the ▲ or ▼ **cursor key** [7].

The selected option is highlighted.

The PRESET memory location FACTORY contains the factory setting (↗ 6-71).

FACTORY x	
SAVE 1	Factory
SAVE 2	Factory
SAVE 3	Factory
SAVE 4	Factory
SAVE 5	user saved; 01.09.2002 22:00
SAVE 6	Factory
SAVE 7	Factory
SAVE 8	Factory
SAVE 9	Factory
SAVE10	Factory
SAVE11	Factory

4. Press the **function key** .

The setting is defined to be the instrument default setting and is marked with the sign x.

Activating the instrument default setting

5. Press the  **function key** in the  **menu**.

The current instrument default setting is loaded and the SYS menu is leaved. The signal generators's user interface is activated again.

You can call up the factory default setting by the menu MAIN directly (↗ 6-79).

NOTE

If no user-defined settings have been defined, the PRESET function key  is assigned the FACTORY PRESET, e.g. the factory default setting (↗ 6-71).

6.3.2 Displaying the Current Instrument Setting (STATUS Menu)

What the settings are for

Selecting the STATUS menu

From the STATUS menu, you can display an overview of the principal current instrument settings.

1. Press the **SYS key** [3].
2. Select the **STATUS** menu with the **◀** or **▶** cursor key [6].

The principal signal generators parameters and the current settings are listed in a table.

SYS-Menu		STATUS
RF Frequency	100.000000 MHz	
RF Freq Offset	0.0 Hz	
RF Level	-30.0 dBm	
RF Level Offset	0.0 dB	
RF Output	OFF	
LF Gen Frequency	1.0000 kHz	
LF Gen Voltage	100 nV	
LF Gen Output	OFF	
UCOR	OFF	
RF Freq Sweep Mode	OFF	
RF Level Sweep Mode	OFF	
LF Freq Sweep Mode	OFF	
Ampl modulation	OFF	
Freq modulation	OFF	
Phase modulation	OFF	
I/Q modulation	OFF	

PRESET STATUS FILE CONFIG SERVICE INFO

Explanation of parameters

RF Frequency	RF frequency	(↗ 6-74)
RF Freq Offset	RF frequency offset	(↗ 6-74)
RF Level	RF level	(↗ 6-74)
RF Level Offset	RF level offset	(↗ 6-74)
RF Output	State of RF output	(↗ 6-74)
LF Gen Frequency	LF frequency	(↗ 6-77)
LF Gen Voltage	LF level	(↗ 6-77)
LF Gen Output	State of LF output	(↗ 6-77)
UCOR	State of an user-defined correktion list	(↗ 6-137)
RF Freq Sweep Mode	State of RF frequency sweep	(↗ 6-104)
RF Level Sweep Mode	State of RF level sweep	(↗ 6-109)
LF Freq Sweep Mode	State of LF frequency sweep	(↗ 6-115)
Ampl Modulation	State of amplitude modulation	(↗ 6-90)
Freq Modulation	State of frequency modulation	(↗ 6-90)
Phase Modulation	State of phase modulation	(↗ 6-93)
I/Q Modulation	State of I/Q modulation	(↗ 6-98)

6.3.3 User-Defined Settings (FILE Menu)

What the settings are for

You can save user-defined settings and load them when required from the FILE menu. You can also print out a screenshot.



Selecting the FILE menu

1. Press the **SYS key** [3].
2. Select the **FILE** menu with the ◀ or ▶ **cursor key** [6].

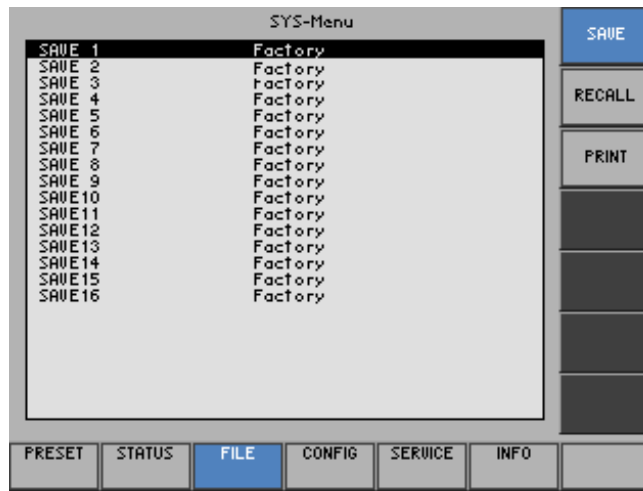
The menu name is highlighted and the appropriate functions are assigned to the function keys [13].



Function key assignment

	Saves a user-defined setting	(↗ 6-169)
	Loads a user-defined setting	(↗ 6-169)
	Prints out a screenshot	(↗ 6-171)

6.3.3.1 Saving and Loading User-Defined Settings

Use

When you switch on the R&S SM300, those settings that were valid when the R&S SM300 was last switched off are restored.

The R&S SM300 also lets you save and load user-defined settings.

You can save 50 different settings (SAVE 1 to 50). When the R&S SM300 is delivered, the factory settings (Factory) are loaded in the SAVE memory locations.

Saving user-defined settings

1. Set up the R&S SM300 for the measurement you want to perform (➤ 6-71).

2. Press the **SAVE** function key in the **FILE** menu.

A table containing the available settings is displayed (memory locations).

SAVE 1	Factory
SAVE 2	Factory
SAVE 3	Factory
SAVE 4	Factory
SAVE 5	Factory
SAVE 6	Factory
SAVE 7	Factory
SAVE 8	Factory
SAVE 9	Factory
SAVE10	Factory
SAVE11	Factory
SAVE12	Factory
SAVE13	Factory
SAVE14	Factory
SAVE15	Factory
SAVE16	Factory

3. Select a setting with the **▲** or **▼** cursor key [7].

The selected option is highlighted.

4. Press the **ENTER** key [5].

An entry field for entering a file name is displayed. The default setting is "user saved".



5. Enter a new file name from the **numerical keys** [12] or from an external keyboard (➤ 3-44).

6. Press the **ENTER** key [5].

The current setting is saved and the text "Factory" is replaced by the file name, the date and time.

SAVE 1	Factory
SAVE 2	Factory
SAVE 3	Factory
SAVE 4	Factory
SAVE 5	user saved ; 11/26/02 11:57A
SAVE 6	Factory
SAVE 7	Factory
SAVE 8	Factory
SAVE 9	Factory
SAVE10	Factory
SAVE11	Factory
SAVE12	Factory
SAVE13	Factory
SAVE14	Factory
SAVE15	Factory
SAVE16	Factory

Loading user-defined settings

1. Press the **RECALL** function key in the **FILE** menu.

A table containing the available settings is displayed (memory locations).

SAVE 1	Factory
SAVE 2	Factory
SAVE 3	Factory
SAVE 4	Factory
SAVE 5	user saved ; 11/26/02 11:57A
SAVE 6	Factory
SAVE 7	Factory
SAVE 8	Factory
SAVE 9	Factory
SAVE10	Factory
SAVE11	Factory
SAVE12	Factory
SAVE13	Factory
SAVE14	Factory
SAVE15	Factory
SAVE16	Factory

2. Select a setting with the **▲** or **▼** cursor key [7].

The FACTORY memory location contains the factory setting (↗ 6-71).

SAVE 1	Factory
SAVE 2	Factory
SAVE 3	Factory
SAVE 4	Factory
SAVE 5	user saved ; 11/26/02 11:57A
SAVE 6	Factory
SAVE 7	Factory
SAVE 8	Factory
SAVE 9	Factory
SAVE10	Factory
SAVE11	Factory
SAVE12	Factory
SAVE13	Factory
SAVE14	Factory
SAVE15	Factory
SAVE16	Factory

3. Press the **ENTER** key [5].

The following message is displayed.

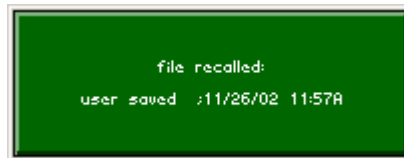

The setting you have selected is loaded and the SYS menu is leaved. The signal generators's user interface is activated again.

NOTE

If you frequently use one of the saved settings and want to load it quickly, you can define this setting to be the PRESET (default setting) and call it directly at any time. (↗ 6-79, 6-166).

6.3.3.2 Printing out a Screenshot

Use

The R&S SM300 prints out (printer) or saves (USB stick) a current screenshot when you press the SYS key and an overview of the principal current instrument settings. A printer with a USB device connector or a USB stick is required.

Selecting the output unit

1. Press the **PRINT** function key in the **FILE** menu.

A table containing the available parameters is displayed.

2. Select the **PRINTER** parameter with the **▲** or **▼** cursor key [7].

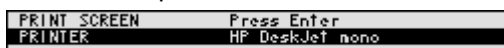

3. Press the **ENTER** key [5].

A selection field containing the available settings is displayed. The default setting is “HP Deskjet mono”.

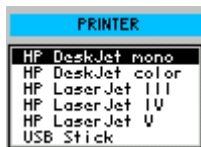

4. Select a setting with the **rotary knob** [11].
5. Press the **ENTER** key [5] to close the selection field.
The setting is saved and the printer driver is loaded.

Printing out a screenshot

1. Connect a printer to the **USB device connector** [20].
2. Select a printer for the output unit (↗ 6-171).
3. Press the **PRINT** function key in the **FILE** menu.

A table containing the available parameters is displayed.

4. Select the **PRINT SCREEN** parameter with the ▲ or ▼ cursor key [7].

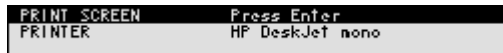

5. Press the **ENTER** key [5].

The following message is displayed.



A current screenshot and an overview of the principal current instrument settings (↗ 6-167) is printed out, e.g.:

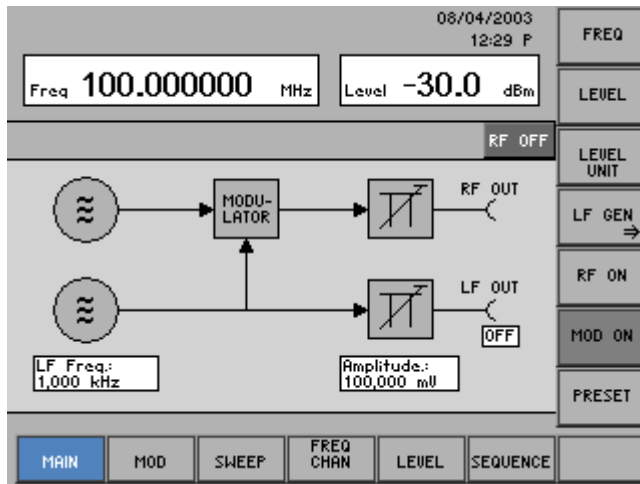

UMT SM300

Rohde & Schwarz, Munich

Version 1.04
from 16.08.2004

```

RF Frequency      100.000000 MHz
RF Freq Offset   0.0 Hz
RF Level         -30.0 dBm
RF Level Offset  0.0 dB
RF Output        OFF
LF Gen Frequency 1.0000 kHz
LF Gen Voltage   100 mV
LF Gen Output    OFF
UCOR             OFF
RF Freq Sweep Mode OFF
RF Level Sweep Mode OFF
LF Freq Sweep Mode OFF
Ampl modulation OFF
Freq modulation  OFF
Phase modulation OFF
IQ modulation    OFF
    
```

Saving the screenshot as a bitmap (.bmp) in the USB stick

1. Connect the USB stick to the **USB device connector** [20].
2. Select the USB stick for the output unit (↗ 6-171).
3. Press the **PRINT** function key in the **FILE** menu.

A table containing the available parameters is displayed.

4. Select the **PRINT SCREEN** parameter with the ▲ or ▼ cursor key [7].



5. Press the **ENTER** key [5].

An entry field for entering a file name is displayed. The default setting is "SM_Date_Time".



NOTE: If you wish you can enter a new file name from the **numerical keys** [12] or from an external keyboard (↗ 3-44).

6. Press the **ENTER** key [5].

The current screenshot before you press the SYS button is saved as a bitmap (.bmp) in the USB stick.

When the USB stick is not connected the following message is displayed:

NOTE



- Connect the USB stick to the **USB device connector** [20] and confirm the message by pressing the **ENTER** key [5].

6.3.4 System Settings (CONFIG Menu)

What the settings are for

You can configure the general system parameters for time/date, reference source, instrument interface and screen saver from the CONFIG menu.

Selecting the CONFIG menu

1. Press the **SYS key** [3].
2. Select the **CONFIG** menu with the **◀** or **▶** cursor key [6].

The menu name is highlighted and the appropriate functions are assigned to the function keys [13].

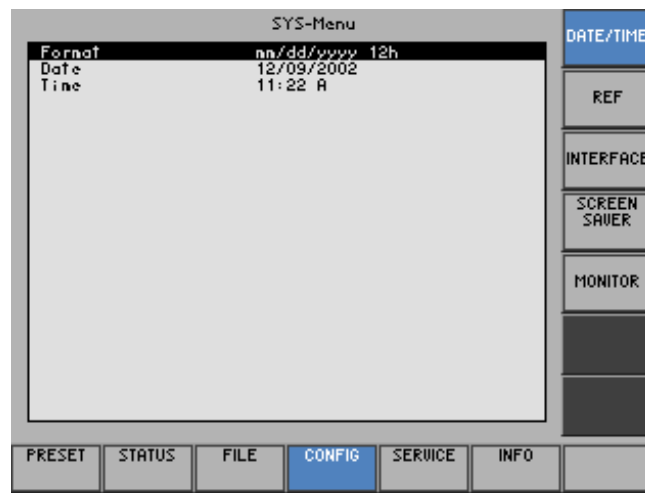

Function key assignment

DATE/TIME	Sets the date and time	(↗ 6-175)
REF	Selects an internal or external reference source	(↗ 6-177)
INTERFACE	Configures the instrument interfaces	(↗ 6-178)
SCREEN SAVER	Sets the screen saver mode	(↗ 6-181)
MONITOR	Selects an internal or external monitor	(↗ 6-183)

6.3.4.1 Setting the Date and Time of Day

Use

When you save a setting (➤ 6-169), it is time-stamped using the time provided by the internal real-time clock.

When you set the internal real-time clock, you can choose between two date and time display format options and modify the parameters.

- **dd.mm.yyyy** **24 h clock**
- **mm/dd/yyyy** **12 h clock**

where: d - day
 m - month
 y - year

Selecting the display format

1. Press the **DATE/TIME** functions key in the **CONFIG** menu.

A table containing the available parameters is displayed.

2. Select the **Format** parameter with the **▲** or **▼** cursor key [7].

Format	dd.mm.yyyy	24h
Date	02.09.2002	
Time	09:29	

3. Press the **ENTER** key [5].

A selection field containing the available settings is displayed. The default setting is "dd.mm.yyyy".

Format
dd.mm.yyyy 24h
mm/dd/yyyy 12h

4. Select a setting with the **rotary knob** [11].
 5. Press the **ENTER** key [5] to close the selection field.
- The setting is saved and the display format updated.

Setting
the date

1. Press the **DATE/TIME** function key in the **CONFIG** menu.
A table containing the available parameters is displayed.
2. Select the **Date** parameter with the **▲** or **▼** cursor key [7].

Format	dd.mm.yyyy 24h
Date	02.09.2002
Time	09:31

3. Press the **ENTER** key [5].
An entry field containing the current setting is displayed.

Date	02.09.2002
------	------------

4. Enter a new value (↵ 5-58).
5. Press the **ENTER** key [5].
The setting is saved and displayed.

Setting
the time

1. Press the **DATE/TIME** function key in the **CONFIG** menu.
A table listing the available parameters is displayed.
2. Select the **Time** parameter with the **▲** or **▼** cursor key [7].

Format	dd.mm.yyyy 24h
Date	02.09.2002
Time	09:31

3. Press the **ENTER** key [5].
An entry field containing the current setting is displayed.

Time	09:31
------	-------

4. Enter a new value (↵ 5-58).
5. Press the **ENTER** key [5].
The setting is saved and displayed.



6.3.4.2 Selecting an Internal or External Reference Source

Use

The R&S SM300 acting as the frequency standard for all internal oscillators can use the internal reference source (**internal**) or an external reference source (**external**). A 10 MHz crystal oscillator is used as the internal reference source. When the default setting is activated (internal reference), a 10 MHz frequency is output at the REF OUT rear-panel connector [27] to synchronize other devices to the R&S SM300 reference frequency, for example.

When the “Reference external” setting is activated, the EXT REF IN connector [26] is used as the input for an external frequency standard. All the R&S SM300’s internal oscillators are synchronized to this external reference frequency (also 10 MHz).

Selecting the reference source

1. When required, connect the external reference source to the EXT REF IN connector [26].
2. Press the  function key in the  menu.
The current reference source setting is displayed.
3. Select the **Reference: INT/EXT** parameter with the \blacktriangle or \blacktriangledown cursor key [7].



```

Reference: INT/EXT  intern
External Reference  10 MHz
  
```

4. Press the **ENTER** key [5].
A selection field containing the available settings is displayed. The default setting is “internal”.

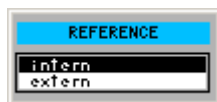

```

REFERENCE
intern
extern
  
```

5. Select a reference source with **rotary knob** [11].
6. Press the **ENTER** key [5].
The setting is saved and the R&S SM300 frequency standard is taken from a new source.

NOTE

If there is no reference signal when you switch over to an external reference, the message PLL UNLOCK is output after a short delay to indicate that there is no sync.

Selecting the external reference source

1. Press the **REF** function key in the **CONFIG** menu.

The current reference source setting is displayed.

2. Select the **External Reference** parameter with the **▲** or **▼** cursor key [7].

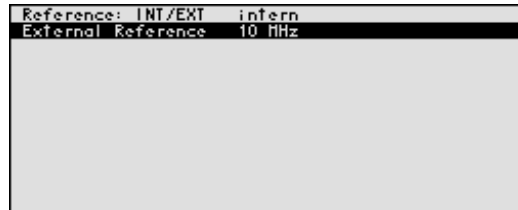

3. Press the **ENTER** key [5].

A selection field containing the available settings is displayed. The default setting is "10 MHz".

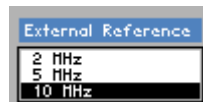

4. Select a reference source with **rotary knob** [11].
5. Press the **ENTER** key [5].

The setting is saved and the R&S SM300 frequency standard is taken from a new source.

6.3.4.3 Configuring the Instrument Interfaces

Use

The R&S SM300 can be remote-controlled via the existing USB host interface [19]. The R&S SM300 automatically detects an existing connection to a PC and also automatically switches to remote control in the default setting (AUTO).

Switchover between internal USB master (local control on the instrument) and external USB master (remote control via PC) is effected by means of a USB master switch.

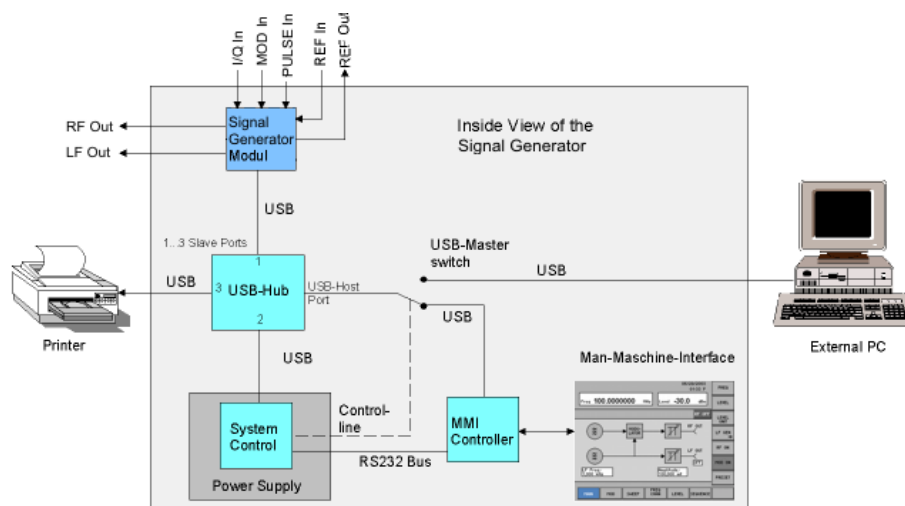

The behaviour of the USB master switch can be controlled via the following settings:

- **Auto**
The AUTO setting is the standard configuration of the USB master switch and allows flexible switching between the local control mode on the R&S SM300 and remote control via PC. This setting allows the instrument to automatically find a connected PC and switch immediately to “remote control”. Under Windows™, the R&S SM300 is recognized as a new USB device, and is thus available for software applications on the PC.

When you press the SYS key [3], the R&S SM300 can be switched to “local mode” at any time. The PC and the R&S SM300 are thus physically disconnected. Reactivate the AUTO setting to switch the R&S SM300 again to “remote control”.

- **Instrument**
The INSTRUMENT setting is required if the R&S SM300 is to be controlled only via the front panel (local control), irrespective of a PC connection. This setting avoids automatic switchover to “remote control”.

When you switch the INSTRUMENT setting to AUTO, an existing PC is recognized, and the R&S SM300 automatically switches to “remote control”.

Setting the
USB master selector

- **Extern**

If EXTERNAL is set, the USB master switch is in the “remote control” mode and the R&S SM300 can only be controlled via a PC.

When you press the SYS key [3], the R&S SM300 can be switched again to “local mode” at any time, for example for changing settings. Reactivate the EXTERNAL setting to switch the R&S SM300 again to “remote control”.

1. Press the **INTERFACE** function key in the **CONFIG** menu.

The current USB master setting is displayed.



2. Press the **ENTER** key [5].

A selection field containing the available settings is displayed. The default setting is Auto.



3. Select a setting with **rotary knob** [11].
4. Press the **ENTER** key [5] to close the selection field.
The setting is saved.

NOTE

With remote control, the local control mode of the R&S SM300 is deactivated and can only be reactivated by pressing the SYS key [3] on the front panel. Switching between remote control and local control takes approx. 2 s.

6.3.4.4 Setting the Screen Saver Mode

Use

The R&S SM300 has a screen-saver function that turns off the screen [14] after a certain time. There are a number of timing options for screen turn-off:

- **none**
The screen is always on.
- **5 min**
The screen is turned off after 5 minutes.
- **30 min**
The screen is turned off after 30 minutes.

If the instrument is in remote-control mode and the results are being displayed on the controller (PC monitor) the screen can be switched off.

- **picture**
The screen displays when the instrument is in remote-control mode.
- **black**
The screen is switched off.

Activating the screen saver

1. Press the  function key in the  menu.

A table listing the available parameters is displayed.

2. Select the **Screen saver** parameter with the **▲** or **▼** cursor key [7].



3. Press the **ENTER** key [5].

A selection field containing the available settings is displayed. The default setting is "none".

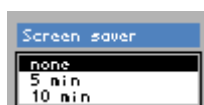

4. Select a setting with **rotary knob** [11].
5. Press the **ENTER** key [5].

The setting is saved and the screen saver is activated or de-activated.

Activating the Screen saver in remote-control mode

1. Press the **SCREEN SAVER** function key in the **CONFIG** menu.

A table listing the available parameters is displayed.

2. Select the **REMOTE** parameter with the **▲** or **▼** cursor key [7].

Screen saver	5 min
REMOTE	black

3. Press the **ENTER** key [5].

A selection field containing the available settings is displayed. The default setting is “black”.

REMOTE
black
picture

4. Select a setting with **rotary knob** [11].

5. Press the **ENTER** key [5].

The setting is saved and the screen disconnection in the remote-control mode is activated or de-activated.

With the “black” setting, the screen is, of course, black, and only the green LED [2] indicates that the R&S SM300 is in remote-control mode.

With the “picture” setting, the following message is displayed on the screen with the R&S SM300 in remote-control mode:

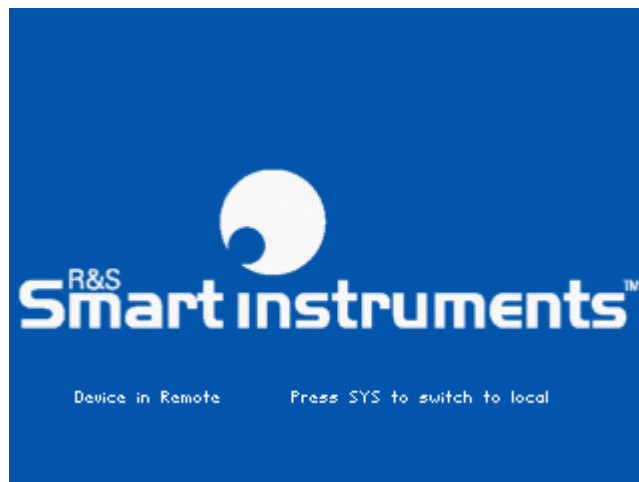

NOTE

With remote control, the local control mode of the R&S SM300 is deactivated and can only be reactivated by pressing the SYS key [3] on the front panel. Switching between remote control and local control takes approx. 2 s.

6.3.4.5 Selecting an Internal or External Monitor

Use Screen display is possible via the internal monitor or an external monitor.

Selecting the monitor

- **intern**
Screen display is via the built-in colour TFT display.
 - **extern**
Screen display is via the connected monitor.
1. If required, connect a monitor to the MON connector [24].
 2. Press the **MONITOR** function key in the **CONFIG** menu.
The current screen setting is displayed.



3. Press the **ENTER** key [5].
A selection field containing the available settings is displayed. The default setting is "intern".

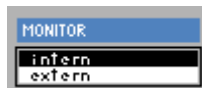

4. Select a setting with **rotary knob** [11].
5. Press the **ENTER** key [5].
The setting is saved.
If the "external" setting is selected, the connected screen shows the active user interface. The internal monitor is switched off.

6.3.5 Service Functions (SERVICE Menu)

What the settings are for

You can call a number of auxiliary functions to be used for servicing or troubleshooting from the SERVICE menu. These functions are not required for normal signal generation with the R&S SM300.

Selecting the SERVICE menu

1. Press the **SYS key** [3].
2. Select the **SERVICE** menu with the ◀ or ▶ **cursor key** [6].

The menu name is highlighted and the appropriate functions are assigned to the function keys [13].



Function key assignment



Performs a selftest

(↗ 6-184)

6.3.5.1 Performing Selftests

Use

The R&S SM300 can perform a module selftest. If there is a fault, the R&S SM300 itself is capable of localizing the defective module.

Starting selftests

1. Press the **SELFTEST** function key in the **SERVICE** menu.

The text SELFTEST is displayed (↗ below).

2. Press the **ENTER key** [5].

The selftest starts. All modules are checked one after the other and the result, "passed" or "failed", is output.

6.3.6 System Informations (INFO Menu)

What the settings are for

Selecting the INFO menu



You can obtain information such as module data, instrument statistics and system messages from the INFO menu.

1. Press the **SYS** key [3].
2. Select the  menu with the ◀ or ▶ **cursor key** [6].

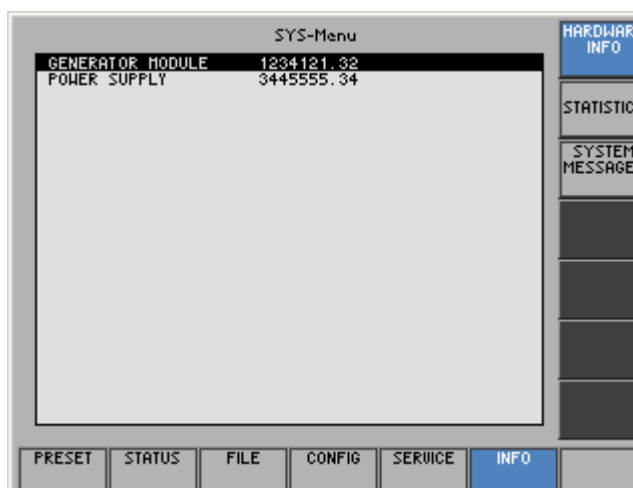
The menu name is highlighted and the appropriate functions are assigned the function keys [13].



Function key assignment

	Displays module data	(↗ 6-186)
	Displays instrument statistics	(↗ 6-186)
	Displays system messages	(↗ 6-187)

6.3.6.1 Displaying Module Data

Use You can display the serial number of the modules installed in the R&S SM300.

Calling module data

- Press the **HARDWARE INFO** function key in the **INFO** menu.

A table listing the current modules and the serial number is displayed.

GENERATOR MODULE	1234121.32
POWER SUPPLY	3445555.34

6.3.6.2 Displaying Instrument Statistics

Use You can display the following R&S SM300 statistics:

- Model** - model designation
- Serial no.** - serial number
- FW version** - firmware version
- Operation time** - operating hours
- Power ON cycles** - on/off cycles

Displaying instrument statistics

- Press the **STATISTICS** function key in the **INFO** menu.

A table listing the current data is displayed.

Model	SM300
Serial	0123456789
FW version	0.50 from 20.08.2002
Operation time	78 h
Power ON cycles	234

6.3.6.3 Displaying System Messages

Use

You can display the most recent R&S SM300 system messages in their order of occurrence. Operating errors are neither saved nor displayed.

System messages help the service personnel to analyze the instrument and handle errors, and should therefore only be deleted by them.

Displaying system messages

1. Press the **SYSTEM MESSAGES** function key in the **INFO** menu.

A table listing the current system messages is displayed.

2. Select a system message with the **▲** or **▼** cursor key [7].

```

Delete 5 Messages
05.04.04 10:36 SM ERROR 0x8E00: Parameter 0x0000
05.04.04 10:35 SM ERROR 0x8E00: Parameter 0x0000
05.04.04 10:31 SM ERROR 0x8E00: Parameter 0x0000
03.03.04 17:55 SM ERROR 0x8E00: Parameter 0x0000
03.03.04 17:54 SM ERROR 0x8E00: Parameter 0x0000
  
```

3. Press the **ENTER** key [5].



The current system message is clearly displayed with the date and time of their occurrence and the error code.

```

MESSAGE
Date: 05.04.04
Time: 10:35
Message: SM ERROR 0x8E00
Parameter 0x00000010 and 0x0000
  
```

4. Press the **ENTER** key [5] for closing the display.

Deleting system messages (only for service)

1. Press the  function key in the  menu.
The table of current system messages is displayed.
2. Select the first line with the ▲ or ▼ cursor key [7].



3. Press the **ENTER** key [5].
The field for the input of the password is displayed.

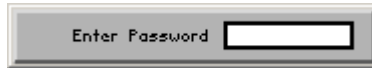

4. Enter the right password and confirm with the **ENTER** key [5].
The error messages are deleted.

Invalid password

If the password is invalid, the following message is displayed:

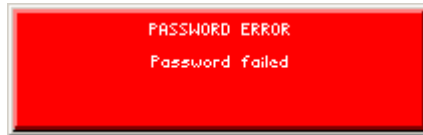

- Confirm the error message with the **ENTER** key [5].
The deleting of the error messages is broken off.

7 Remote Control/PC Software R&S SM300-K1

NOTE

The latest remote control commands and software drivers for the USB-interface of the R&S SM300 can be downloaded from the R&S Smart Instruments internet site:

www.smart-instruments.de

7.1 Applications of PC Software

Performance features

The PC Software R&S SM300-K1 allows convenient operation of the R&S SM300 by remote control via a PC. All functions of the signal generator are supported.

Remote control using the keyboard and the mouse

All functions and parameters can be set with the keyboard and the mouse using menus, toolbars or short keys.

Large display on the PC monitor

The current waveforms as well as parameters and status fields are displayed clearly on the monitor.

7.2 Installation and Configuration

System requirements The PC software runs on Windows™ 2000 and XP operating systems with USB interface.

7.2.1 Installing the PC Software

NOTE To install the PC software, you must have administrator rights on your PC. (↗ Windows™ help).

Introduction The PC software is installed in two steps. Firstly the remote control program for the R&S SM300 is installed. The R&S SM300 must not be connected at this time. Secondly the drivers are installed; at this time the instrument has to be connected.

7.2.1.1 Installing the Program

NOTE The <Back> button enables the user to go back one step during installation. Installation can be interrupted by pressing <Cancel>.

Installation steps for Windows™ 2000

1. Place the CD ROM, which came with the product, in your installation drive. The autorun function automatically initiates installation. Alternatively you may also initiate the installation in the start menu of Windows™ **Start\Run** using the **Setup.exe** from the CD.

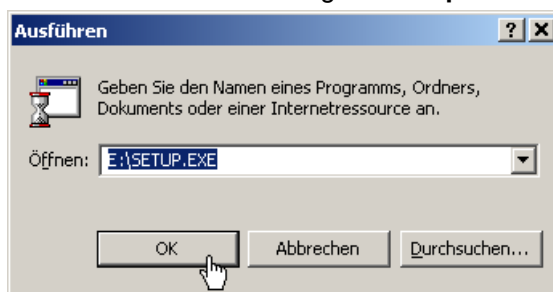

The installation is prepared and the installation wizard appears.

- 2. Click **<Next>** to continue the installation.



- 3. Click **<Browse>** to assign a new directory if you wish to install the program in a directory other than that suggested . Please ensure that all programs from the Smart Instruments series (R&S FS300-K1, SM300-K1 or AM300-K1) are installed in the same directory.
Click **<Next>** to continue the installation.

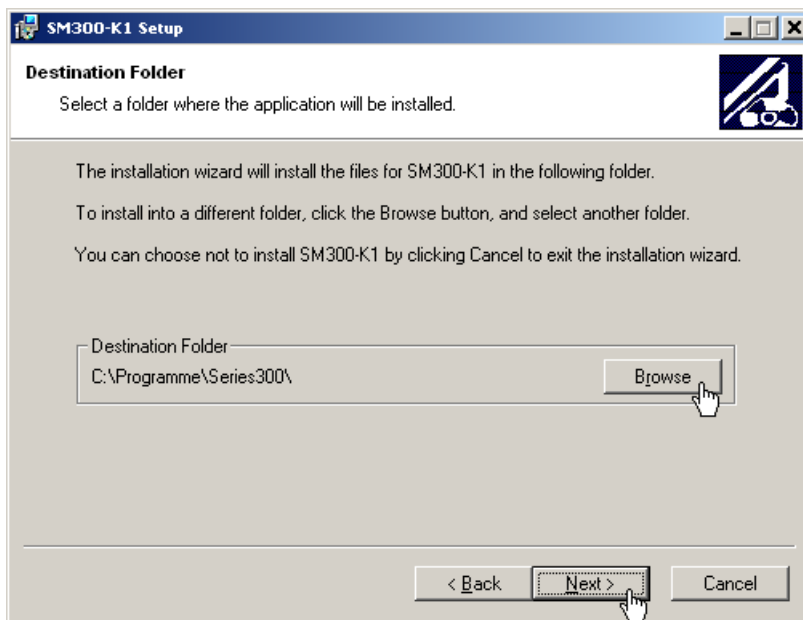

- 4. Click **<Next>** to continue the installation. Installation begins and the data are transferred to the PC. Please wait a moment.

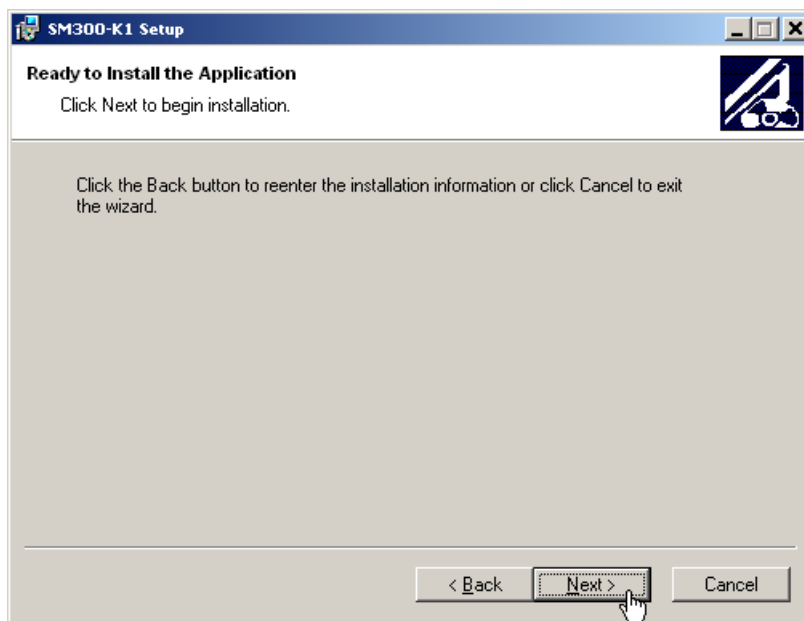

- 5. Click **<Finish>** to successfully complete the installation.

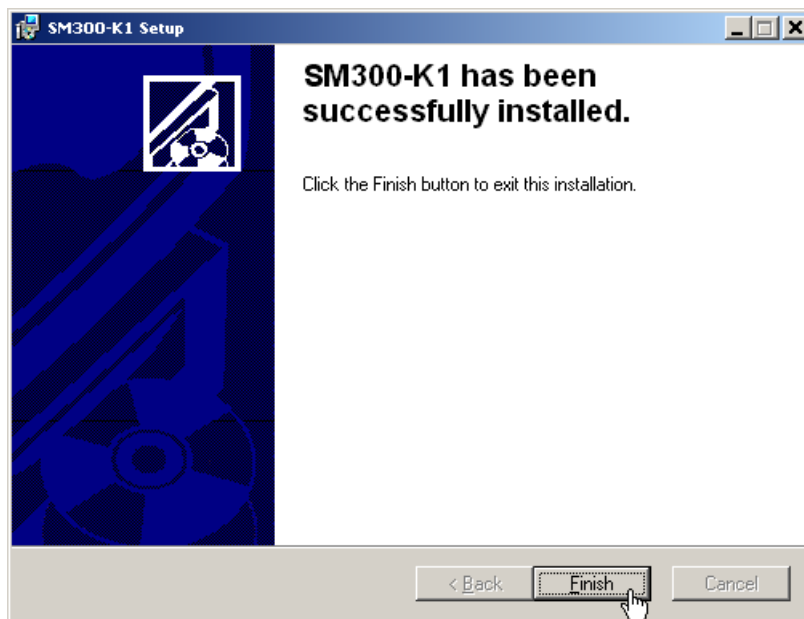

- 6. Click **<Yes>** to restart the computer.

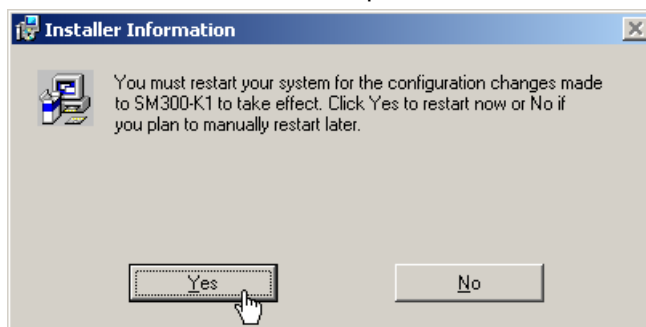

All new settings are now effective and the following appears in the Windows™ **Start\Programs\Rohde & Schwarz\Series 300** start-up menu:



7. Install the device driver now ([↗](#) next section).

7.2.1.2 Installing the Device Drivers

7.2.1.2.1 Installing Steps for Windows™ 2000

Connecting R&S SM300 to the PC

R&S SM300 is connected to the PC via the USB interface. The connection cable has two plug types. Plug A is connected to the computer (↗ computer manual) and plug B is connected to the R&S SM300 (↗ 2-38).

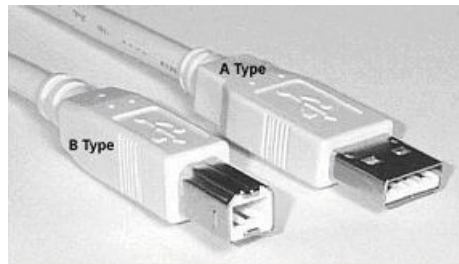

The CD ROM must be in the installation drive in order to install the driver.

1. Switch on the R&S SM300 and the PC.
2. Connect the instrument to the PC with the USB cable. The PC (Windows™) recognizes the connected instrument and reports new hardware. This message appears only when an R&S SM300 is installed for the first time.

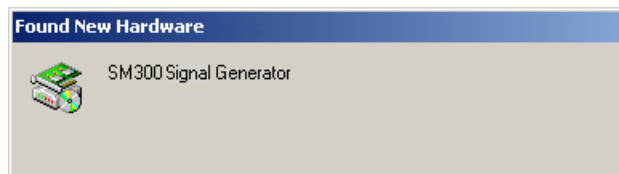

If the R&S SM300 is not automatically recognized, check that the USB master switch of the R&S SM300 is at **AUTO** (↗ 6-179).

Installing device drivers

3. Click **<Next>** to continue the installation.



4. Select **Search for a suitable driver for my device** and click **<Next>** to continue the installation.



- 5. Select **CD-ROM drives** and click **<Next>** to continue the installation.

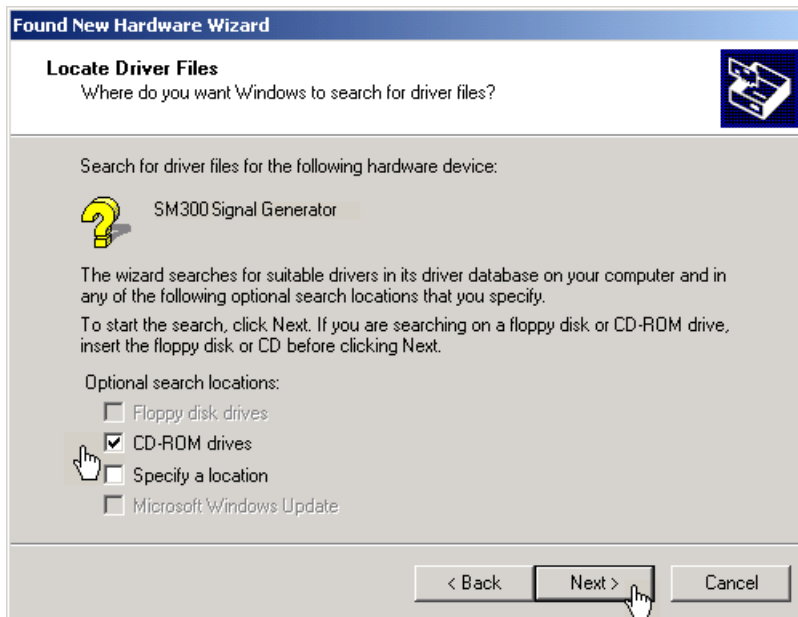

The search results for the driver data are now displayed.

- 6. Click **<Next>** to continue the installation.

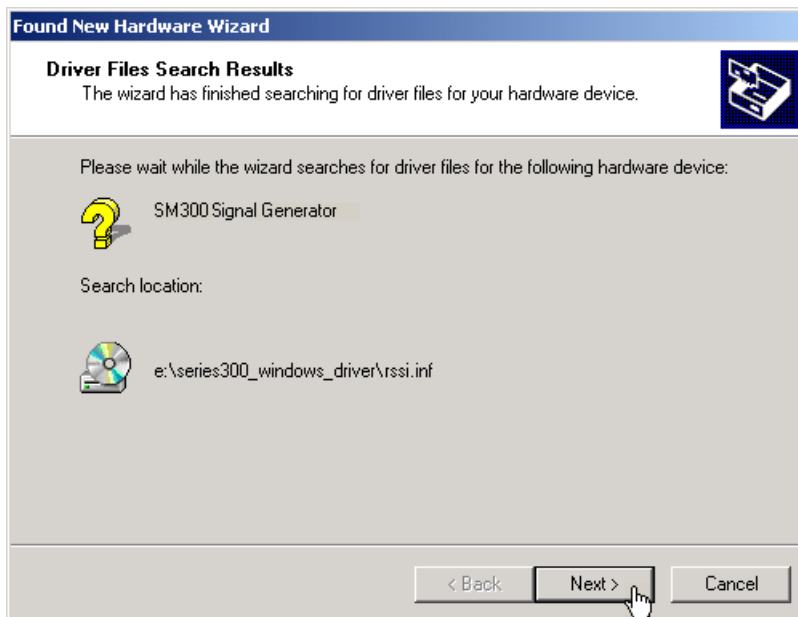

- Click <Finish> to complete the installation.

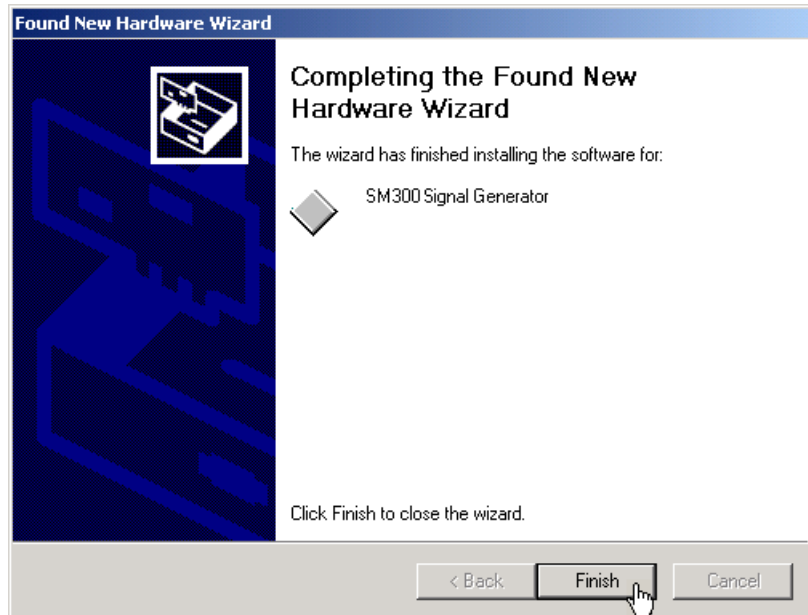

This is followed by the installation of the device driver for the **Rohde & Schwarz Power Supply**. Windows generally "remembers" all the necessary information when installing the Spectrum Analyzer R&S SM300 and installs the Rohde & Schwarz Power Supply without a query. However, depending on the system, the installation assistant might be activated.



In this case, repeat instructions 3. to 7. to successfully complete the installation.

The drivers are now correctly installed and this can be checked using the device manager.

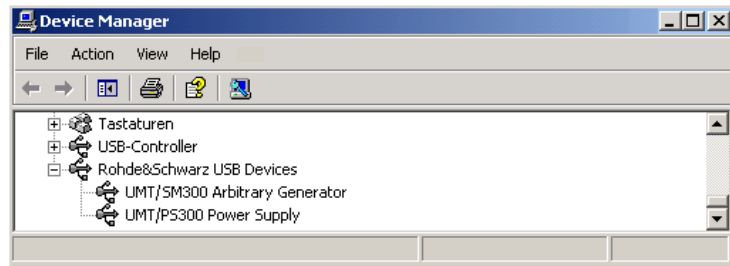

8. Create now the program version for specific instrument (↗ 7-202).

7.2.1.2.2 Installing Steps for Windows™ XP

Connecting R&S SM300 to the PC

R&S SM300 is connected to the PC via the USB interface. The connection cable has two plug types. Plug A is connected to the computer (↗ computer manual) and plug B is connected to the R&S SM300 (↗ 2-38).

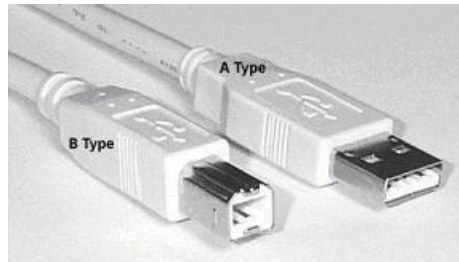

The CD ROM must be in the installation drive in order to install the driver.

1. Switch on the R&S SM300 and the PC.
2. Connect the instrument to the PC with the USB cable. The PC (Windows™) recognizes the instrument when it is connected and reports new hardware. This message appears only when an R&S SM300 is installed for the first time.

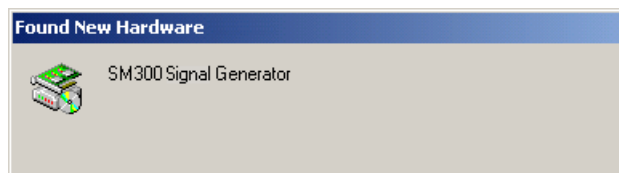

If the R&S SM300 is not automatically recognized, check that the USB master switch of the R&S SM300 is at **AUTO** (↗ 6-179).

Installing device drivers

3. Select **Install the software automatically** and click **<Next>** to continue the installation.



4. Click **<OK>** to continue the installation.

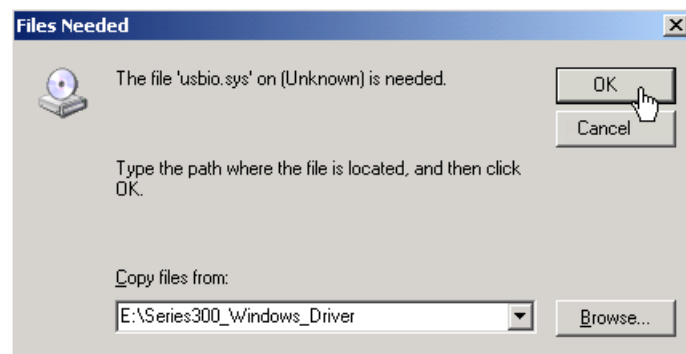

5. Click **<Finish>** to successfully complete the installation.

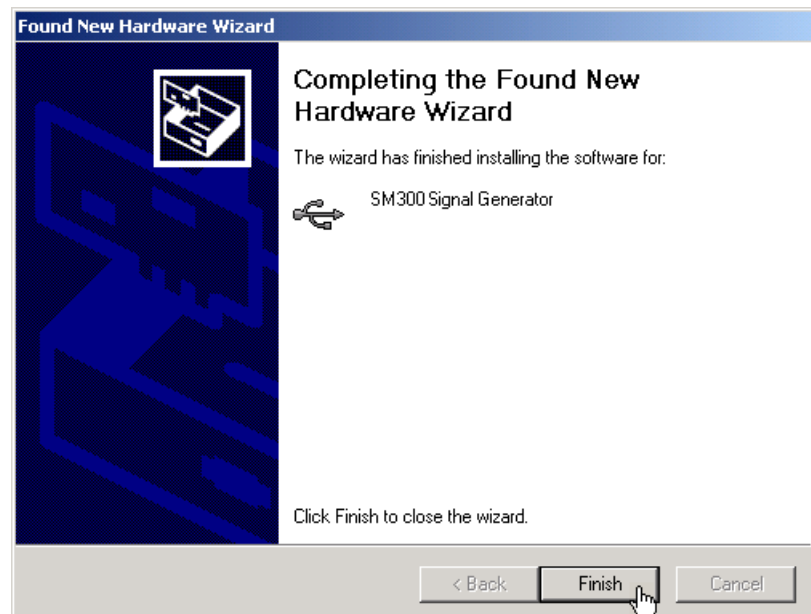

This is followed by the installation of the device driver for the **Rohde & Schwarz Power Supply**. Windows generally "remembers" all the necessary information when installing the Spectrum Analyzer R&S SM300 and installs the Rohde & Schwarz Power Supply without a query. However, depending on the system, the installation assistant might be activated.



In this case, repeat instructions 3. to 5. to successfully complete the installation.

The drivers are now correctly installed and this can be checked using the device manager.

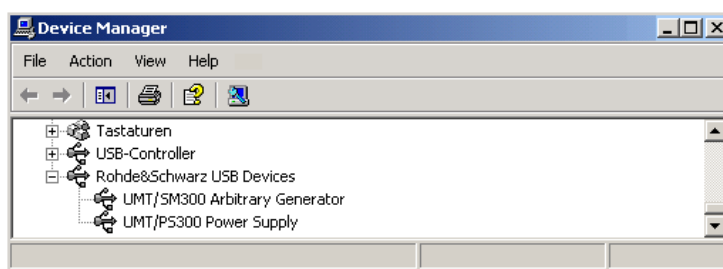

6. Create now the program version for specific instrument (↗ 7-202).

7.2.2 Connecting the PC-Software with the R&S SM300

Introduction

Due to the USB-Technology which is used in the R&S SM300, more than one instrument in the 300 Series can be connected with a PC at the same time. For each instrument a connection with the respective software which allows the opening and remote controlling of the specific instrument has to be created.

The creation of an instrument-specific connection of the Software R&S SM300-K1 by using the provided Series 300 Software Manager is explained in the following section. Before this process can be started, the R&S SM300-K1 Software needs to be installed on your PC (➔ 7-190) and one or more instruments have to be connected to the PC via USB-cable (➔ 7-206).

7.2.2.1 Starting the Series 300 Software Manager

Starting the service program

- In the Windows™ start-up directory select:
Start\Programs\Rohde&Schwarz\Series300\Series 300 Software Manager

The service program initializes. The program interface is divided into two areas:

- I A list of all previously connected Smart instruments
- II Information, status fields and command buttons for authorization

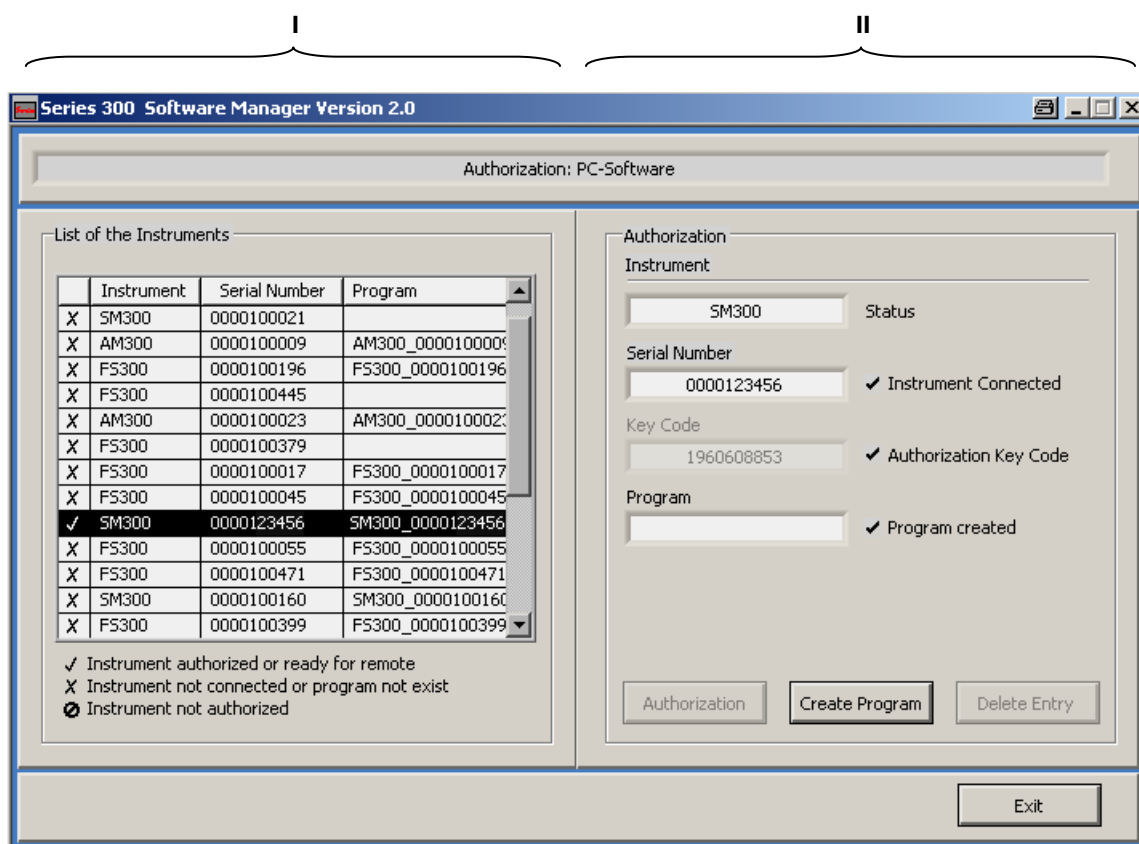

7.2.2.2 Creating the Program Version

Selecting the instrument

1. In I click on the instrument for which you create a link.

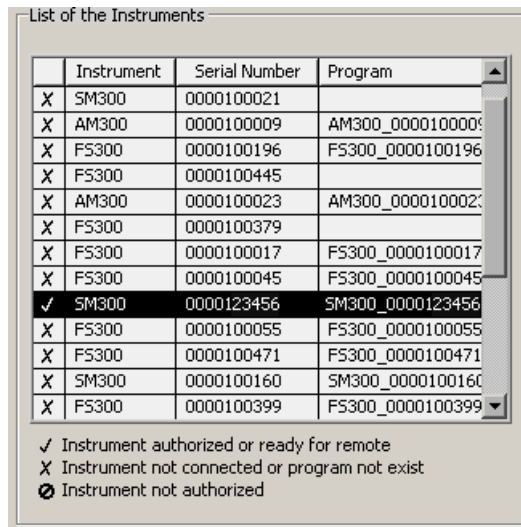

Creating the program version for specific instrument

2. Click <Create Program>. A program version for specific instrument is created and displayed in II with the status (✓). The program number is created from the instrument name (SM300) and the serial number (0000xxxxxx).

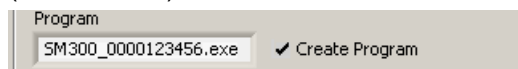

3. In II click <Exit> to close the service program. After correctly creating the program version, the option SM300 0000xxxxxx is available in the Windows™ start-up menu Start\Programs\Rohde & Schwarz\Series300.

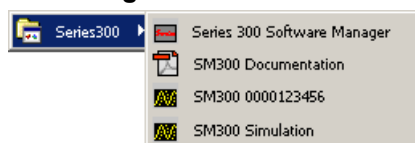

Now the program SM300 0000xxxxxx can be started (↗ 7-207)

7.2.3 Uninstalling the PC Software

Installation steps for
Windows™ 2000

1. Place the CD ROM, which came with the product, in the installation drive. The autorun function automatically initiates installation. Alternatively you may also initiate the installation in the start menu of Windows™ **Start\Run** using the **Setup.exe** from the CD. The uninstallation is prepared and the uninstallation assistant appears.

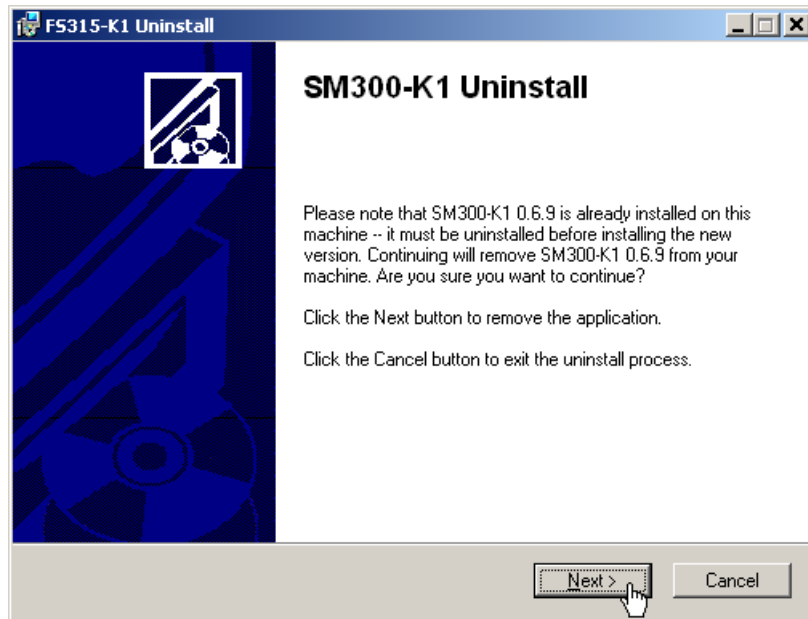

2. Click **<Next>** to continue the uninstallation.

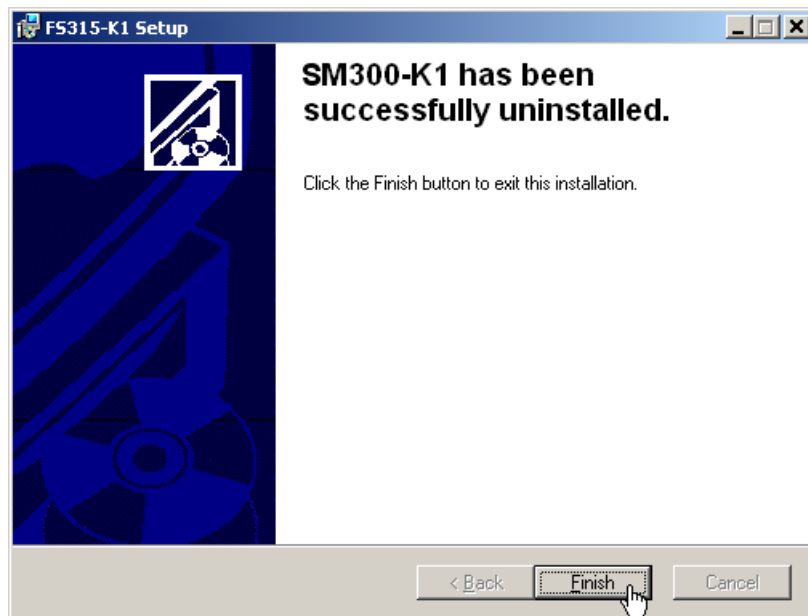

3. Click **<Finish>** to complete the uninstallation.

NOTE

The PC software can also be uninstalled using the Windows™ control panel.

7.2.4 Update PC Software

Introduction

Old versions of the PC-Software can be updated with the Series 300 Software Manager. Therefore the old version has to be uninstalled (↗ 7-203). The new version can then be installed (↗ 7-190). After that, the links which already existing to the listed instruments have to be updated manually.

Starting the service program

1. Start the Series 300 Software Manager (↗ 7-201).
The service program initializes and the window „Authorization: PC-Software“ is displayed.
2. Click on the top bar **Authorization: PC-Software** and choose “Service: Update PC-Software” from the menu.

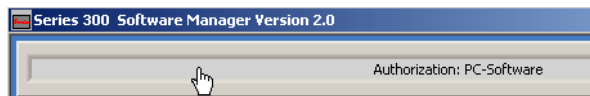

The “Update PC-Software” window is displayed and has the following two partitions:

- I List of all Smart-Instruments that have been previously connected
- II Display of the current version of the program and the available version

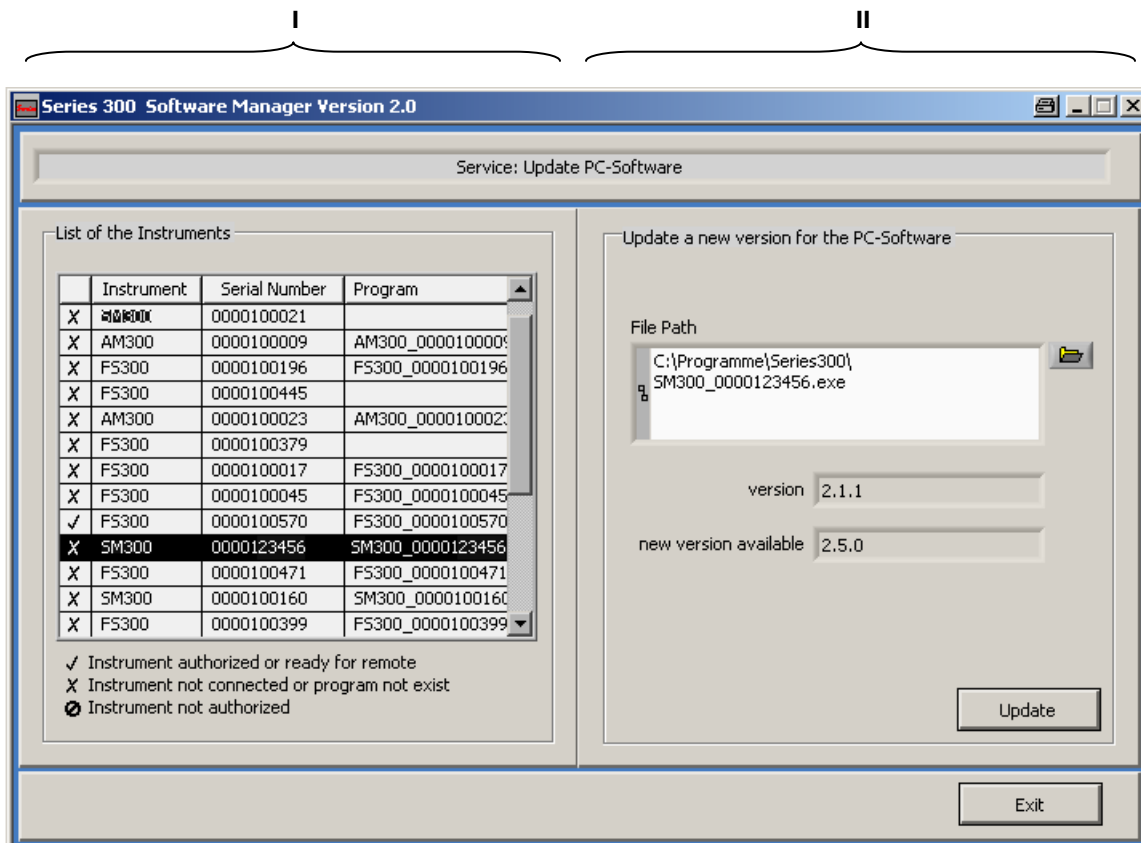

Selecting the instrument

- In I click on the instrument for which you wish to update a link.

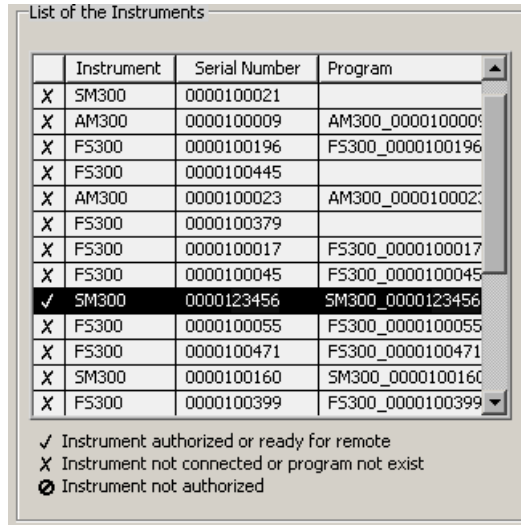

Updating the link

- Click in II on <Update>, to update the displayed link.
- Click in II on <Exit>, to shut down the service program. The updated connection **SM300 0000xxxxxx** is displayed in the Windows™ Start Menu **Start\Programme\Rohde & Schwarz\Series300**.

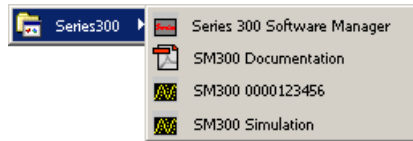

Now the program **SM300 0000xxxxxx** can be started (➤ 7-207).

7.3 Starting the Remote Control

7.3.1 Connecting the Instrument to the PC

NOTE

PC software SM300-K1 must be installed before you can connect the R&S SM300 to the PC (↗ 7-190).

Introduction

R&S SM300 is connected to the PC via the USB interface. The connection cable has two plug types. Plug A is connected to the computer (↗ computer manual) and plug B is connected to the R&S SM300 (↗ 2-38).

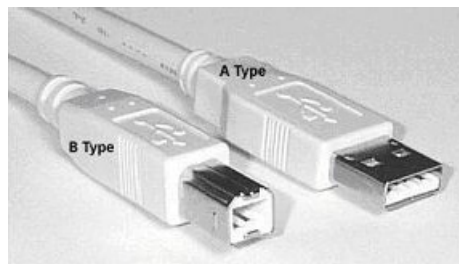
**Prepare remote control**

1. Switch on the R&S SM300 and the computer.

Connect instrument to PC

2. Connect the instrument to the computer with the USB cable. The computer recognizes the attached instrument and sets up a connection. The following message appears on the monitor of the R&S SM300:

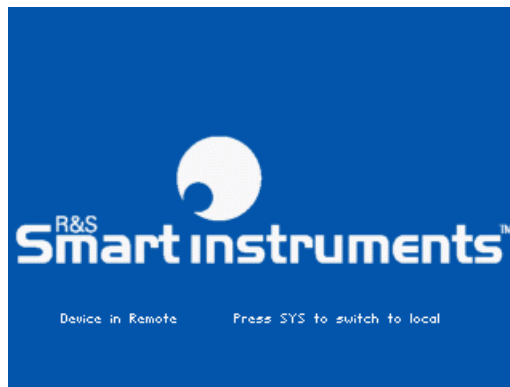

If the R&S SM300 is not automatically recognized, please check that the USB master switch of the R&S SM300 is at position **AUTO** (↗ 6-179).

NOTE

In remote control mode, control of the R&S SM300 is deactivated and can only be reactivated by pressing the SYS key on the front panel of the instrument. Switching from remote to local control takes approximately 8 seconds.

7.3.2 Starting the Program

NOTE

Remote control of a signal generator can only be executed with the appropriate device-specific program version.

Starting the program

1. In the Windows™ start-up directory click on:
Start\Programs\Rohde & Schwarz\Series 300\SM300 0000xxxxxx

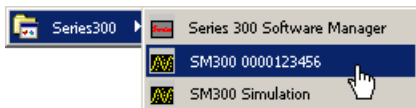

If the link is not available

2. If the program does not start, then click with the right mouse button in the Windows™ start-up directory on:
Start\Programs\Rohde & Schwarz\Series 300\SM300 0000xxxxxx
Click **Properties**.

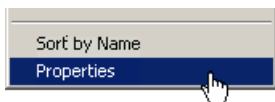

Click **<OK>** to create a link between the program and start-up directory.

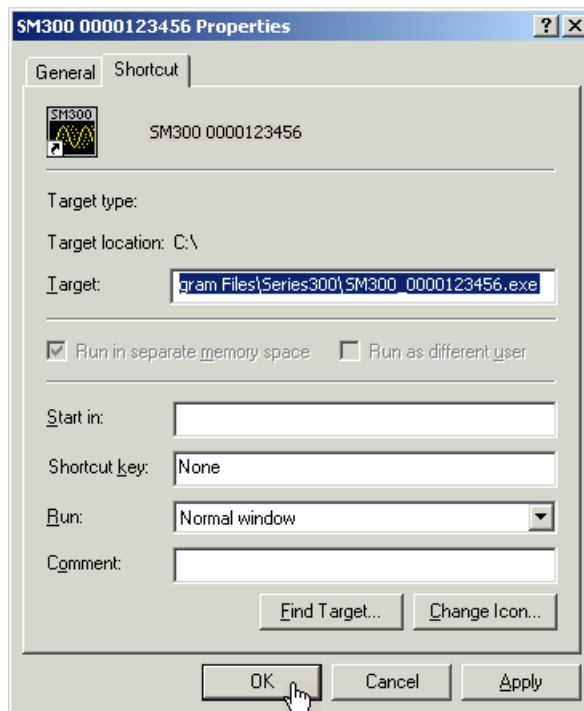

Start the program again (↗ above, instruction 1.)

Program interface

The program starts up and you may begin using the R&S SM300 remote control.

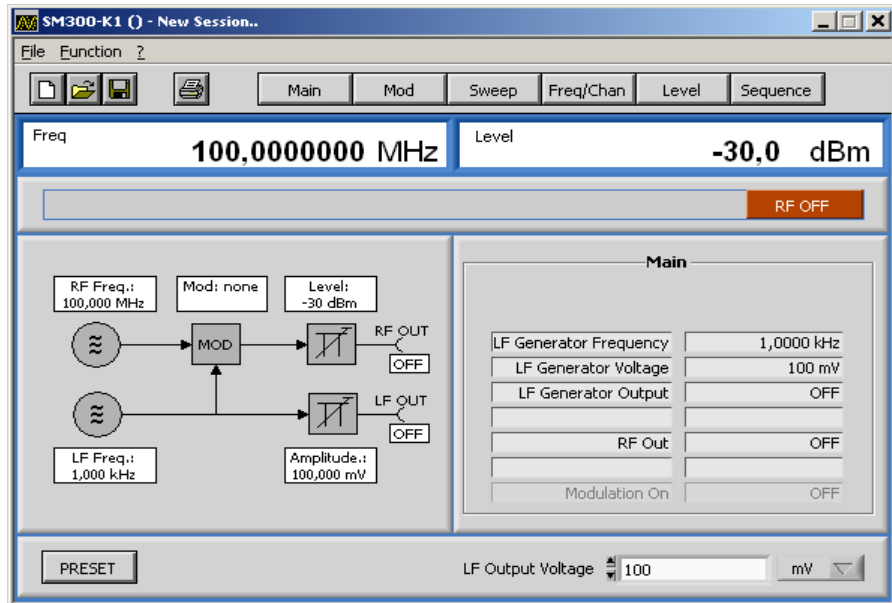

Loading the current instrument settings

A new session opens automatically when you start the program. The current R&S SM300 settings are loaded. After loading, you may start using the R&S SM300 remote control.

NOTE

If the message **Device not connected** appears on the program interface, check the connection to the instrument (↗ 7-206).

7.3.3 Closing the Remote Control

Closing the program 1. In Windows™ click on the close symbol **x**.

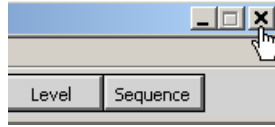

You may also select the option **Exit** in the pull-down menu **File**.

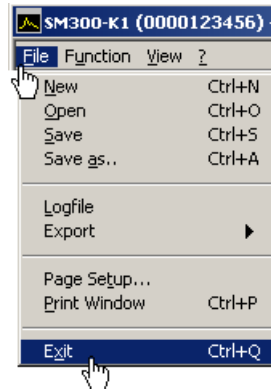

Closing the remote control

2. Remove the USB cable from one side or press the BACK/SYS key at the front panel of the R&S SM300.

Switching between remote and local control takes approximately 8 seconds.

7.4 Getting Started

Task

In this example a signal with a frequency of **250 kHz** and an amplitude of **10 mV** is applied to the RF output [9].

Resetting the R&S SM300

1. Start the PC software (SM300 0000123456.EXE) on your PC.



Alternatively you may also open a new session when the PC software is already started. To do so, press **<Ctrl+N>**. The default settings are now loaded (➤ 6-71).

Setting the signal frequency 250 kHz

2. Click on the **Freq** display.



Functions are displayed with parameters in the setting area.

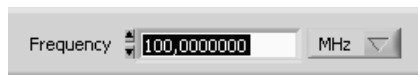

3. Set the measuring unit **<kHz>** for the **Frequency** input window by clicking the mouse.

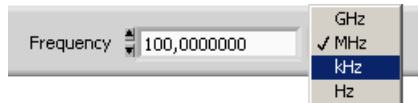

4. Click on the **Frequency** display and enter the value **<250>** with the numeric keys. Complete the input with the **<Enter>** button.



Setting the signal level 10 mV

- Click in the **Level** display on the measuring unit **dBm**.



Functions are displayed with parameters in the setting area.

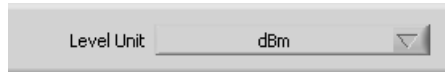

- Set the measuring unit **<mV>** by clicking the mouse.

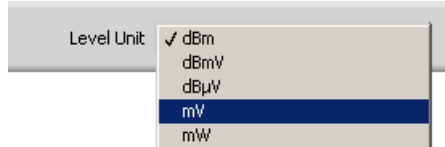

- Click on the **Volt** display.



Functions are displayed with parameters in the setting area.

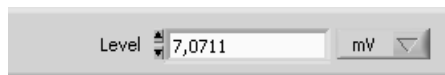

- Click on the **Level** display and enter the value **<10>** with the numeric keys. Complete the input with the **<Enter>** button.

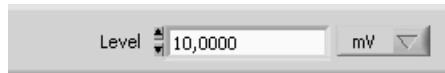

Switching on the output

- In the function display **Main**, click in the line **RF Out** for switching the output **<ON>**.

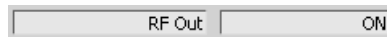

7.5 Control Concept

7.5.1 PC Monitor Display

Introduction The PC monitor provides continuous information about the current settings of the R&S SM300. The display format for the settings and the insertion of the function displays depend on the current settings.

Structure of the program interface The program interface is divided into three areas:

- I Diagram
- II Menus
- III Functions
- IV Settings

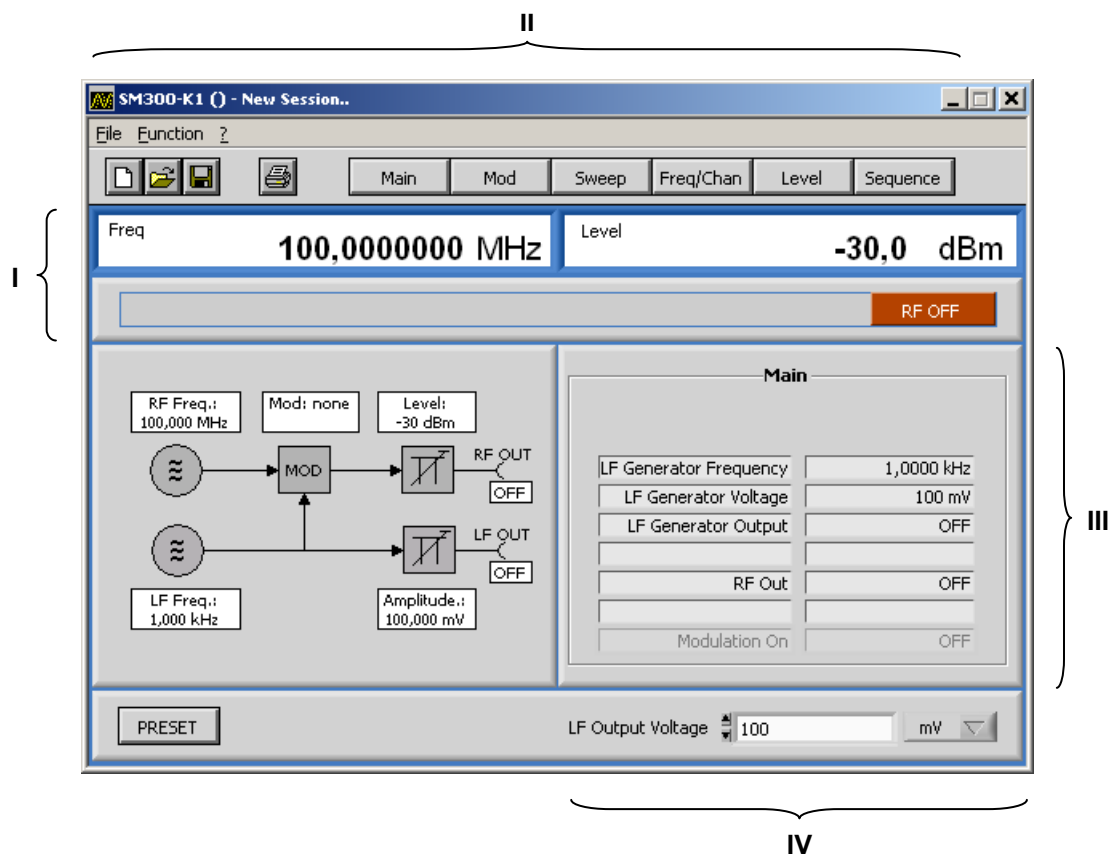

7.5.1.1 Diagram

Diagram displays The diagram area contains:

- Frequency (a) and level display (b)
- Status line (c)

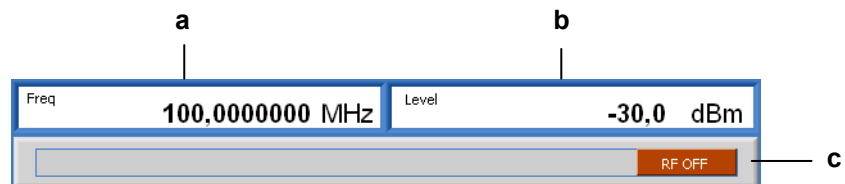

7.5.1.2 Menus

Calling up and displaying menus

- Different pull-down menus can be accessed in the menu area.

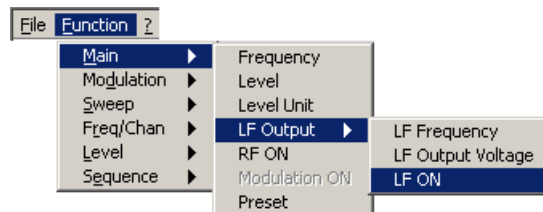

- In addition, Windows™-typical menu items can be called up via a toolbar (icons).



- Menus for setting the measuring parameters and functions are also available as a toolbar and can be selected directly.



NOTE

The ▶ arrow after a menu option in the pull-down menu indicates that a submenu will appear after opening.

7.5.1.3 Functions

Main functions display

The **main functions** of the RF and LF generator of the R&S SM300 are always displayed in the left part of the function display.

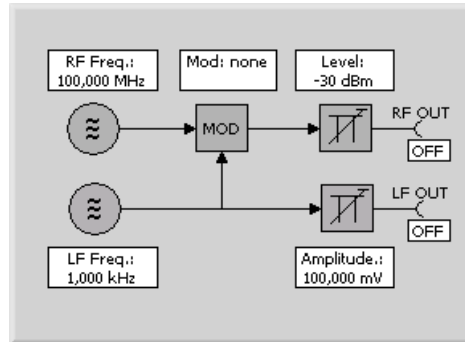

Inserting specific functions

In the right part of the function display, different function displays according to the menu selection (↗ 7-213), e.g. **Sweep**.

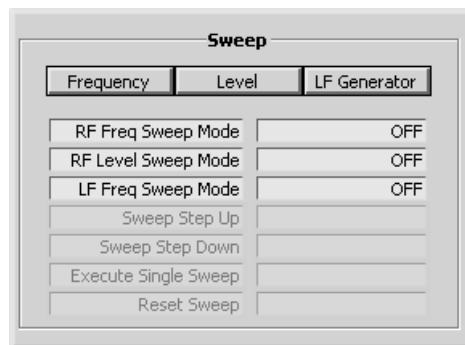

NOTE: If a selection is not highlighted, it has currently no function (current setting).

7.5.2 Setting the Parameters

General

Parameters can be set in different ways:

- Clicking the button

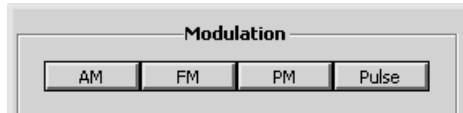

- Toggling of switch states in a line of the function display directly

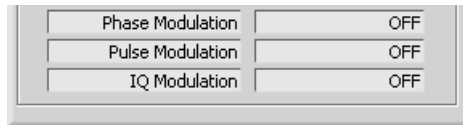

- Entering the parameters in the setting area

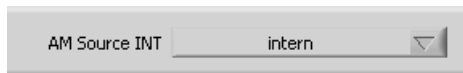

The keyboard and mouse can be used for the settings.

Parameters are selected and entered in the setting area only.

Entering the parameters in the setting area

1. Click in that display where the parameters have to be changed, e.g. **Freq.**



Functions are displayed with parameters in the setting area.

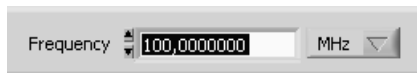

2. Select the assigned settings in the selection field e.g. **kHz**.

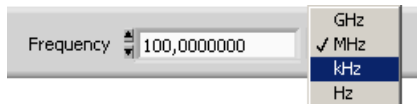

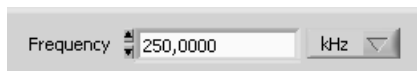

And/or enter numeric parameters in the input field, e.g. **250**.



7.6 Overview of all Menus and Functions (Shortcuts)

7.6.1 File

New Session	Ctrl+N	Begin new session	
Open Session	Ctrl+O	Open saved session	
Save Session	Ctrl+S	Save current session	
Save Session as..	Ctrl+A	Save current session as	
Page Setup...		Page setup for printing	
Print Window	Ctrl+P	Print current window	
Exit	Ctrl+Q	Exit program	

7.6.2 Function

NOTE

Instrument functions are accurately described in chapter 6.

Main	▶	Setting of main parameters	(↗ 7-217)
Modulation	▶	Modulation settings	(↗ 7-218)
Sweep	▶	Sweep settings	(↗ 7-223)
Freq/Chan	▶	Special frequency settings	(↗ 7-227)
Level	▶	Special level settings	(↗ 7-230)
Sequence	▶	User-defined sequences of settings	(↗ 7-233)

7.6.2.1 Main

Main function display (always visible)



Function display (insert with toolbar button Main)

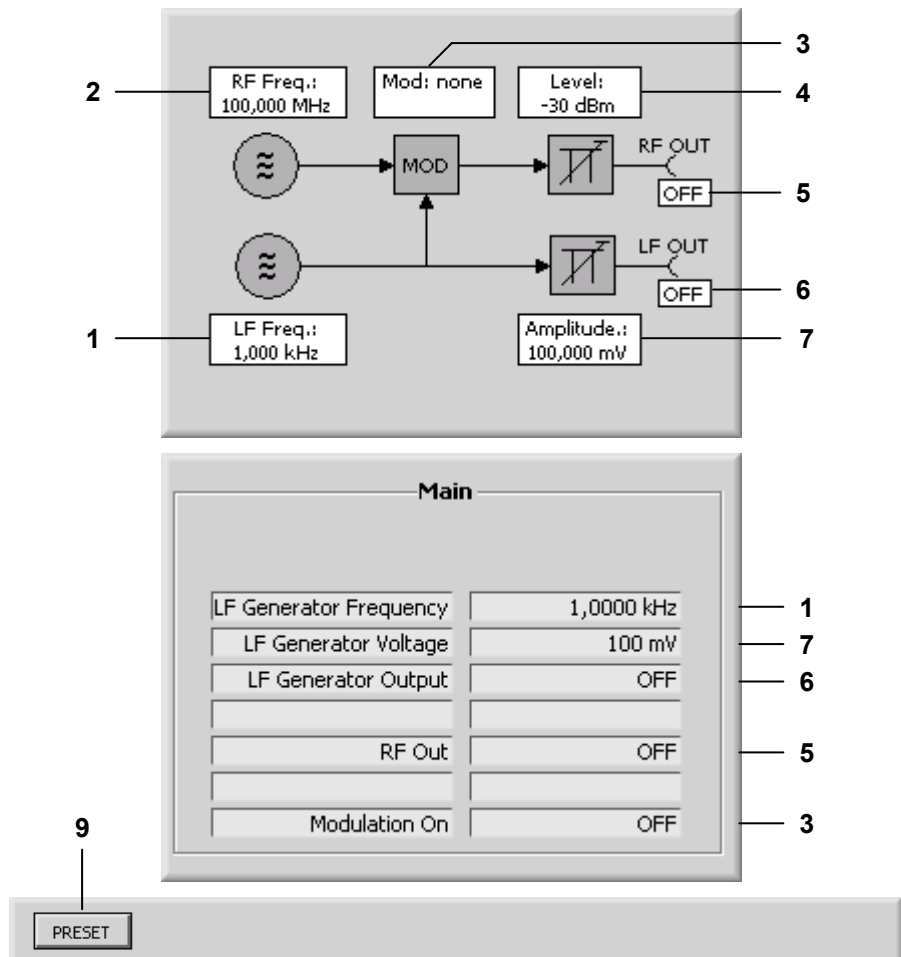

Pull down menu

Frequency	Entering the signal generator output frequency	(2)
Level	Entering the signal generator output level	(4)
Level Unit	Selecting the unit for the output level	(8)
LF Output ▶	Open submenu: Configuring the LF signal	
LF Frequency	Entering the LF generator output frequency	(1)
LF Output Voltage	Entering the LF generator output level	(7)
LF ON	Switching the output signal of the LF generator on/off	(6)
RF ON	Switching the generator output signal on/off	(5)
Modulation ON	Switching the modulation on/off	(3)
Preset	Loading default setting of R&S SM300	(9)

7.6.2.2 Modulation

Function display
(insert with toolbar
button Modulation)

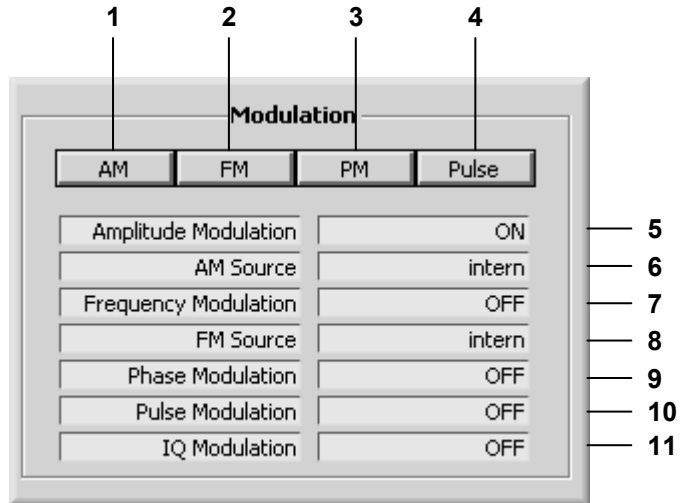

Pull down menu

- | | | |
|-----------------|----------------------------------|-------------|
| Modulation AM ▶ | Open submenu: | (1) |
| | Setting the amplitude modulation | (↗ 7-219) |
| AM ON | Switching modulation on/off | (5) |
| AM Source INT | Selecting the modulation source | (6) |
| Modulation FM ▶ | Open submenu: | (2) |
| | Setting the frequency modulation | (↗ 7-220) |
| FM ON | Switching modulation on/off | (7) |
| FM Source | Selecting the modulation source | (8) |
| Modulation PM ▶ | Open submenu: | (3) |
| | Setting the phase modulation | (↗ 7-221) |
| PM ON | Switching modulation on/off | (9) |
| MODUL PWM ▶ | Open submenu: | (4) |
| | Setting the pulse modulation | (↗ 7-222) |
| PWM ON | Switching modulation on/off | (10) |
| IQ ON | Switching I/Q modulation on/off | (11) |

NOTE

You can quit the selected submenu (AM, FM, PM, Pulse) with the toolbar button Modulation.

7.6.2.2.1 Amplitude Modulation

Function display
(insert with button
AM)

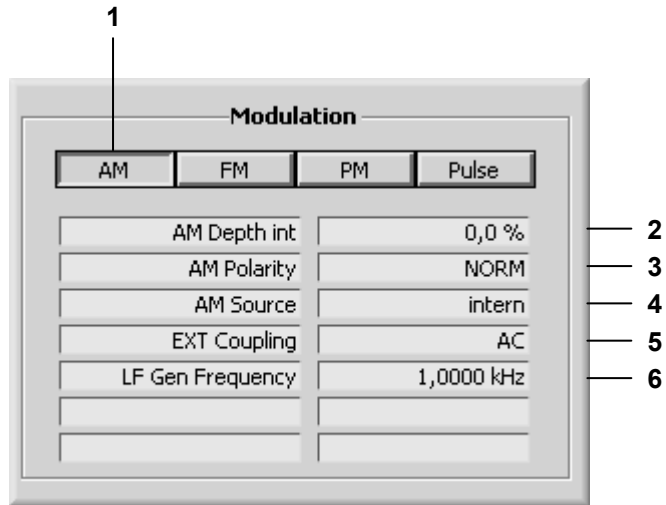

Pull down menu

Modulation AM ▶	Open submenu:	(1)
	Setting the amplitude modulation	
AM Depth	Entering the modulation depth	(2)
AM Polarity	Setting the polarity of the modulation voltage	(3)
AM Source INT	Selecting the modulation source	(4)
AM EXT Coupling	Setting coupling of external LF generator	(5)
LF Frequency	Entering the frequency of the internal LF generator	(6)

7.6.2.2.2 Frequency Modulation

Function display
(insert with button
FM)

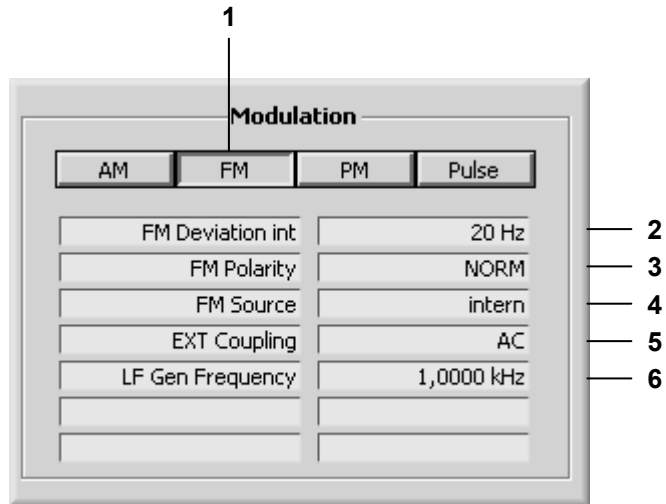

Pull down menu

Modulation FM ▶

Open submenu: (1)
Setting the frequency modulation

- FM Deviation (2) Entering the frequency deviation
- FM Polarity (3) Setting the polarity of the modulation voltage
- FM Source (4) Selecting the modulation source
- FM EXT Coupling (5) Setting the coupling of the external LF generator
- LF Frequency (6) Entering the frequency of the internal LF generator

7.6.2.2.3 Phase Modulation

Function display
(insert with button
PM)

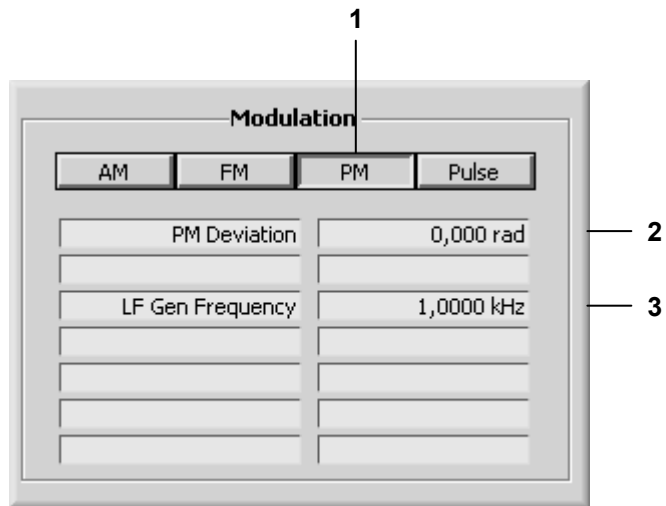

Pull down menu

Modulation PM ▶

Open submenu: (1)
Setting the phase modulation

PM Deviation (2)
Entering the ϕ M deviation

LF Frequency (3)
Entering the frequency of the internal LF generator

7.6.2.2.4 Pulse Modulation

Function display
(insert with button
Pulse)

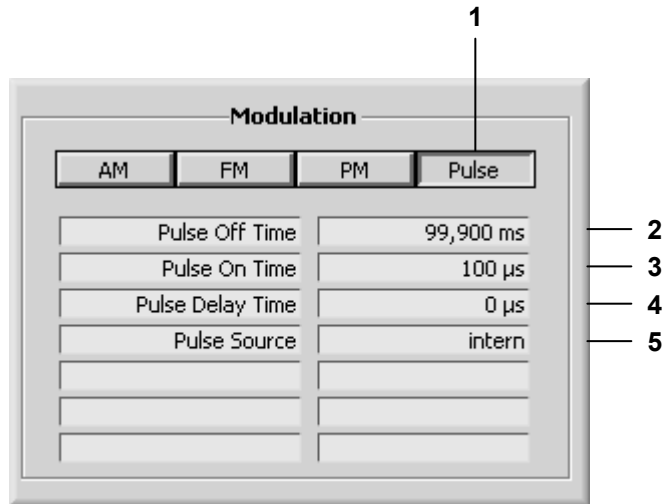

Pull down menu

- | | | |
|-----------------|---------------------------------|-------|
| MODUL PWM ▶ | Open submenu: | (1) |
| | Setting the pulse modulation | |
| PWM Pulse Off | Entering the pulse off time | (2) |
| PWM Pulse On | Entering the pulse on time | (3) |
| PWM Pulse Delay | Entering the pulse delay time | (4) |
| PWM Source INT | Selecting the modulation source | (5) |

7.6.2.3 Sweep

Function display
(insert with toolbar
button Sweep)

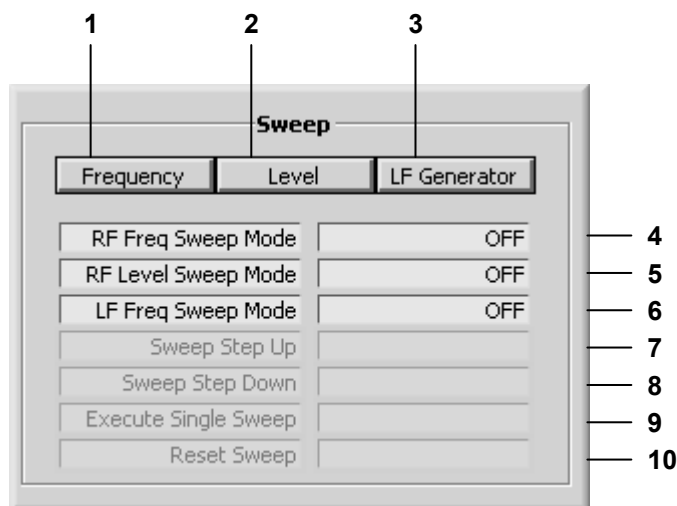

Pull down menu

Frequency Sweep ▶	Open submenu:	(1)
	Configuring the frequency sweep	(↗ 7-224)
Sweep Freq Mode	Setting/starting the sweep mode	(4)
Level Sweep ▶	Open submenu:	(2)
	Configuring the level sweep	(↗ 7-225)
Sweep Level Mode	Setting/starting the sweep mode	(5)
LF Sweep ▶	Open submenu:	(3)
	Configuring the frequency sweep of the internal LF generator	(↗ 7-226)
Sweep Mode	Setting/starting the sweep mode	(6)
	Executing a sweep step up	(7)
	Executing a sweep step down	(8)
Execute Single Sweep	Starting a single sweep	(9)
Reset Sweep	Resetting an ongoing sweep	(10)

NOTE

You can quit the selected submenu (Frequency, Level, LF Generator) with the toolbar button Sweep.

7.6.2.3.1 Configuring the Frequency Sweep

Function display
(insert with button
Frequency)

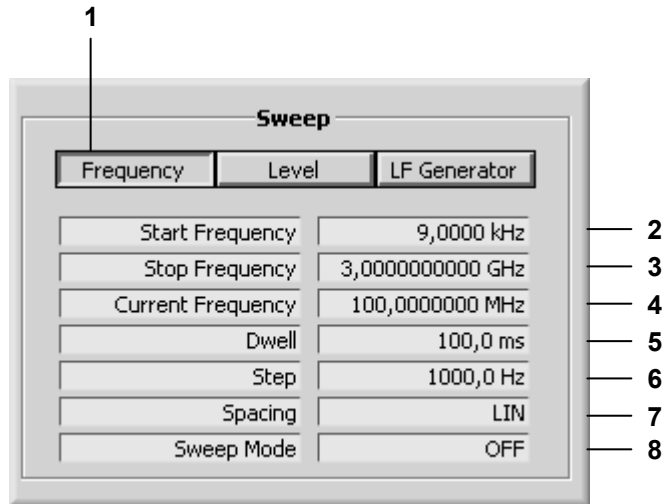

Pull down menu

Frequency Sweep ▶	Open submenu:	(1)
	Configuring the frequency sweep	
Sweep Freq Start	Entering a start frequency	(2)
Sweep Freq Stop	Entering a stop frequency	(3)
	Current frequency value (sweep step)	(4)
Stepsize	Entering a step size	(5)
Sweep Freq Dwell	Entering a dwell time per step	(6)
Sweep Spacing	Setting sweep spacing	(7)
Sweep Freq Mode	Setting/starting the sweep mode	(8)

7.6.2.3.2 Configuring the Level Sweep

Function display
(insert with button
Leve)

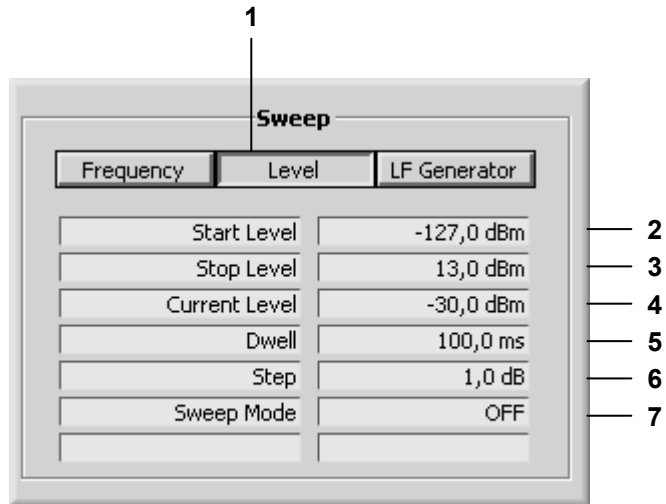

Pull down menu

Level Sweep	▶	Open submenu:	(1)
		Configuring the level sweep	
Sweep Level Start		Entering a start level	(2)
Sweep Level Stop		Entering a stop level	(3)
		Current level value (sweep step)	(4)
Sweep Level Step		Entering a step size	(6)
Sweep Level Dwell		Entering a dwell time per step	(5)
Sweep Level Mode		Setting/starting the sweep mode	(7)

7.6.2.3.3 Configuring the Frequency Sweep of the Internal LF Generator

Function display
(insert with button
LF Generator)

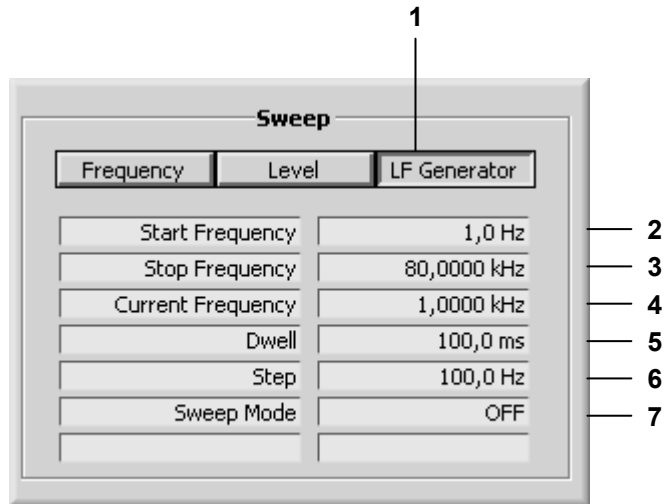

Pull down menu

LF Sweep	▶	Open submenu:	(1)
		Configuring the frequency sweep of the internal LF generator	
Sweep LF Freq Start		Entering a start frequency	(2)
Sweep LF Freq Stop		Entering a stop frequency	(3)
		Current frequency value (sweep step)	(4)
Stepsize		Entering a step size	(6)
Sweep LF Freq Dwell		Entering a dwell time per step	(5)
Sweep Spacing		Setting sweep spacing	
Sweep Mode		Setting/starting the sweep mode	(8)

7.6.2.4 Freq/Chan

Function display
(insert with toolbar
button Freq/Chan)

Frequency / Channel		
Offset	0,0 Hz	1
Stepsize	0,1 Hz	2
Channel List	<none>	3
Channel No.	0	4
Exclude from RCL	OFF	5

Pull down menu

Frequency Offset	Entering the signal generator frequency offset	(1)
Frequency Stepsize	Setting the step size for frequency entry with the rotary knob	(2)
Channel List	Open submenu: Entering channel lists	(3) (↗ 7-228)
Channel No.	Calling the channel number from the channel list	(4)
Exclude Freq from RCL	Holding the current frequency setting	(5)

7.6.2.4.1 Entering Channel Lists

Channel list
(insert with button
Channel List)

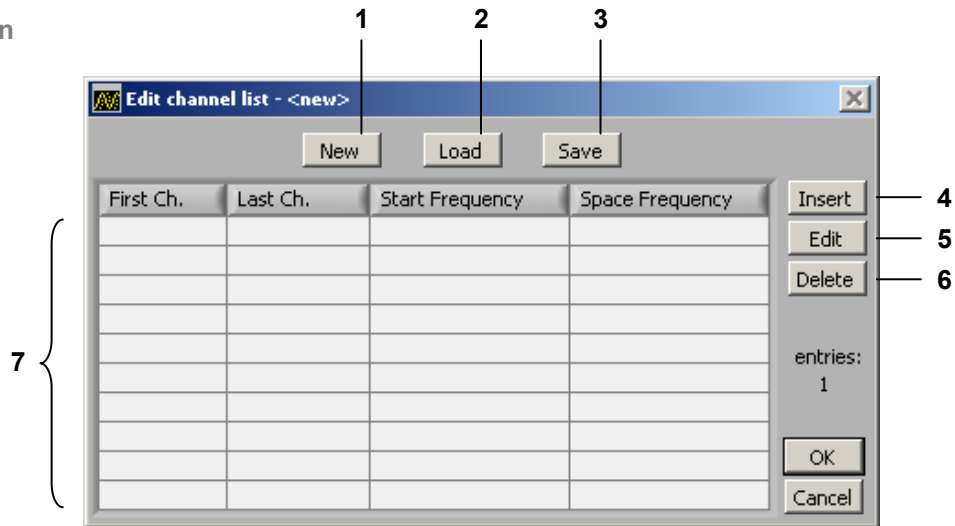

Pull down menu

Channel List

Open submenu:

Entering channel lists

- (1) Creating a new channel list
- (2) Loading a channel list
- (3) Storing a channel list
- (4) **Open entry menu:**
Inserting a list entry (↗ 7-229)
- (5) **Open entry menu:**
Editing a list entry (↗ 7-229)
- (6) **Open line delete menu:**
Deleting a list entry (↗ 7-229)
- (7) Selecting a list entry with the mouse

7.6.2.4.2 Inserting/Editing a List Entry

Entry menu
(insert with button
Insert/Edit)

Function

 / 

Open entry menu:
Inserting a list entry

- (1) Entering a number for the first channel
- (2) Entering a number for the last channel
- (3) Entering a frequency value for the first channel
- (4) Entering a space frequency between the channels

7.6.2.4.3 Deleting a List Entry

Line delete menu
(insert with toolbar
button Delete)

Function



Open line delete menu:
Deleting a list entry

- (1) Entering the line number of the list entry to be deleted
- (2) Entering the number of list entries to be deleted

7.6.2.5 Level

Function display
(insert with toolbar
button Level)

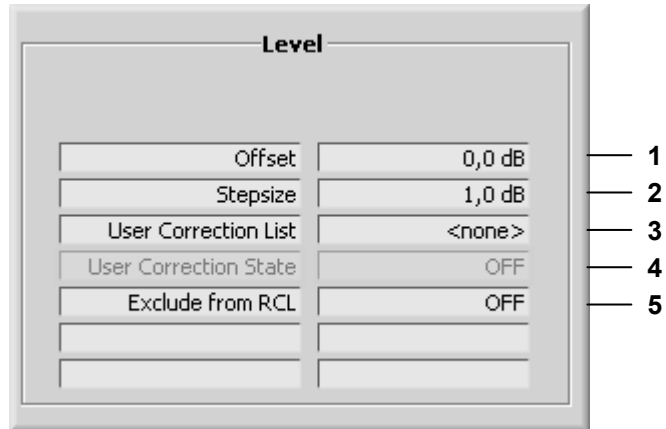

Pull down menu

Level Offset	Entering the signal generator level offset	(1)
Level Stepsize	Setting the step size for level entry with the rotary knob	(2)
LEVEL EMF	Converting the level/voltage display	
User Correction List	Open submenu: Entering correction lists	(3) (↗ 7-231)
	Switching the user-difined level correction on/off	(4)
Exclude Level from RCL	Holding the current level setting	(5)

7.6.2.5.1 Entering Correction Lists

Correction list
(insert with button
User Correction
List)

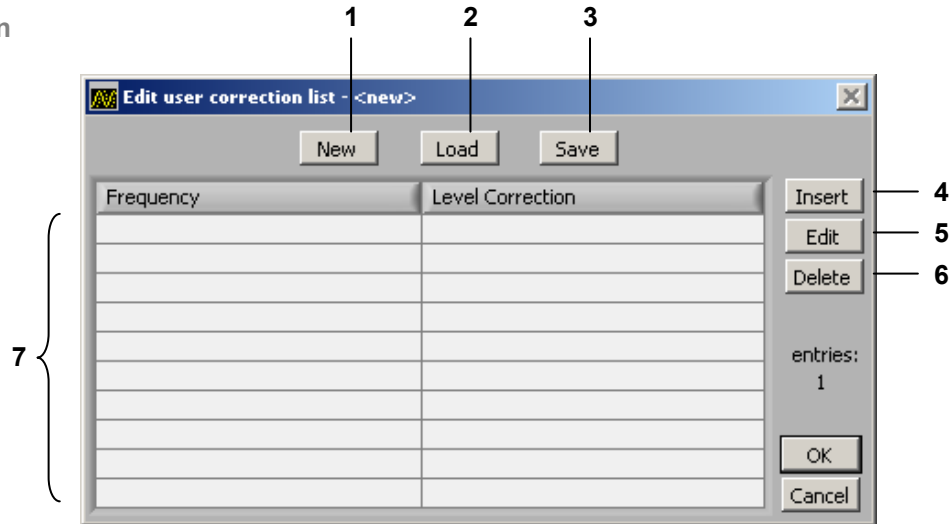

Pull down menu

User Correction List

Open submenu:

Inserting a list entry

- (1) Creating a new correction list
- (2) Loading a correction list
- (3) Storing a correction list
- (4) **Open entry menu:**
Inserting a list entry (↗ 7-232)
- (5) **Open entry menu:**
Editing a list entry (↗ 7-232)
- (6) **Open line delete menu:**
Deleting a list entry (↗ 7-232)
- (7) Selecting a list entry with the mouse

7.6.2.5.2 Inserting/Editing a List Entry

Entry menu
(insert with button
Insert/Edit)

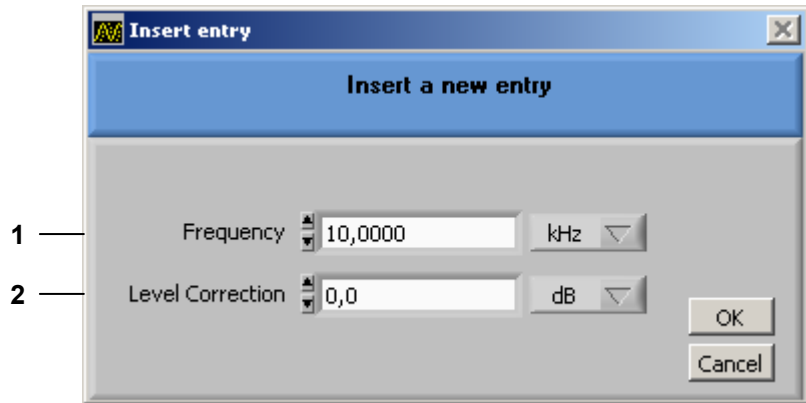

Function



Open entry menu:
Editing a list entry

- (1) Entering a frequency value for level correction
- (2) Entering a level value for level correction

7.6.2.5.3 Deleting a List Entry

Line delete menu
(insert with toolbar
button Delete)

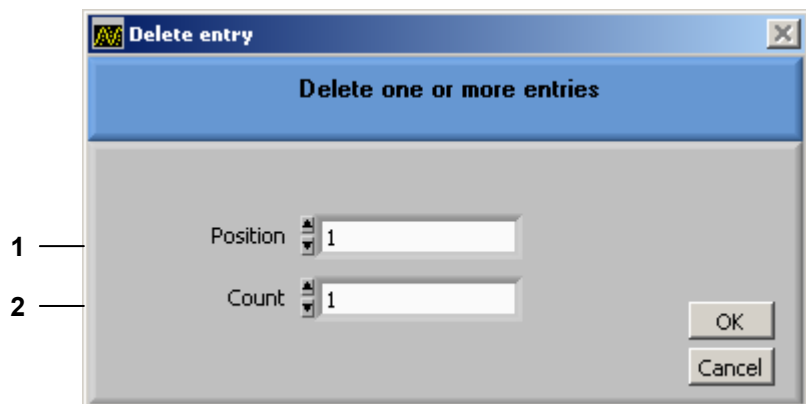

Function



Open line delete menu:
Deleting a list entry

- (1) Entering the line number of the list entry to be deleted
- (2) Entering the number of list entries to be deleted

7.6.2.6 Sequence

Function display
(insert with toolbar
button Sequence)

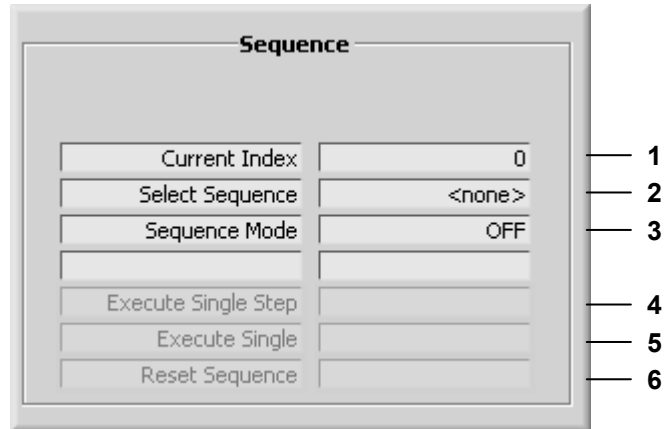

Pull down menu

	Displaying the current sequence steps (index)	(1)
Sequence	Open submenu: Creating a sequence	(2) (↗ 7-234)
Sequence Mode	Setting the sequence mode	(3)
MEMSEQ EXEC Step	Executing the sequence step by step	(4)
Execute Single Sequence	Starting a single sequence	(5)
Reset Sequence	Resetting an ongoing sequence	(6)

7.6.2.6.1 Creating a Sequence List

Sequence list
(insert with button
Sequence)

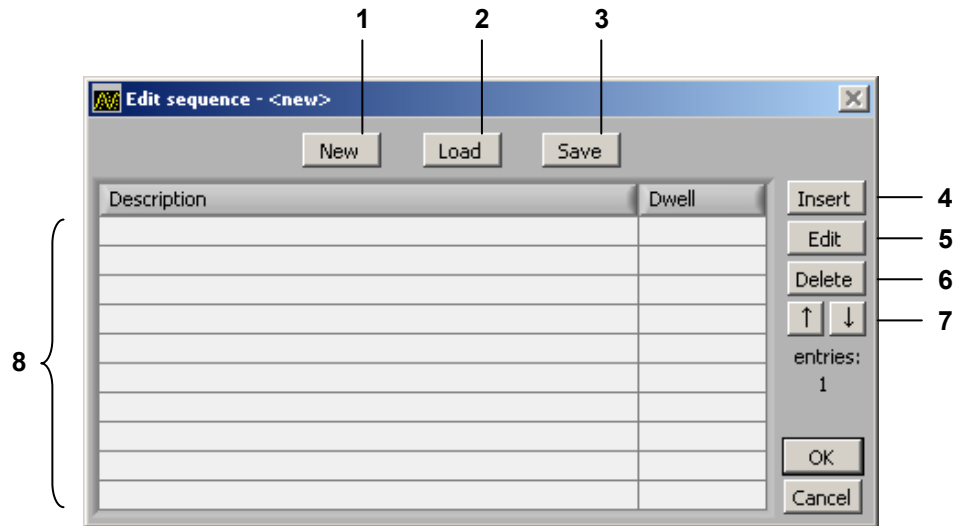

Pull down menu

Sequence

Open list menu:

Editing a sequence list

- (1) Creating a new sequence list
- (2) Loading a sequence list
- (3) Storing a sequence list
- (4) **Open entry menu:**
Inserting a list entry (↗ 7-235)
- (5) **Open entry menu:**
Editing a list entry (↗ 7-235)
- (6) **Open line delete menu:**
Deleting a list entry (↗ 7-235)
- (7) Moving/arranging a list entry
- (8) Selecting a list entry with the mouse

7.6.2.6.2 Inserting/Editing a List Entry

Entry menu
(insert with button
Insert/Edit)

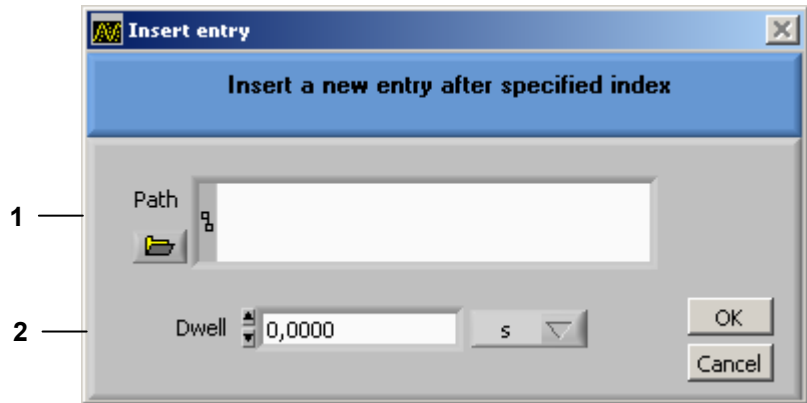

Function



Open entry menu:
Editing a list entry

- (1) Inserting an instrument setting
- (2) Entering the dwell time of the setting

7.6.2.6.3 Deleting a List Entry

Line delete menu
(insert with button
Delete)

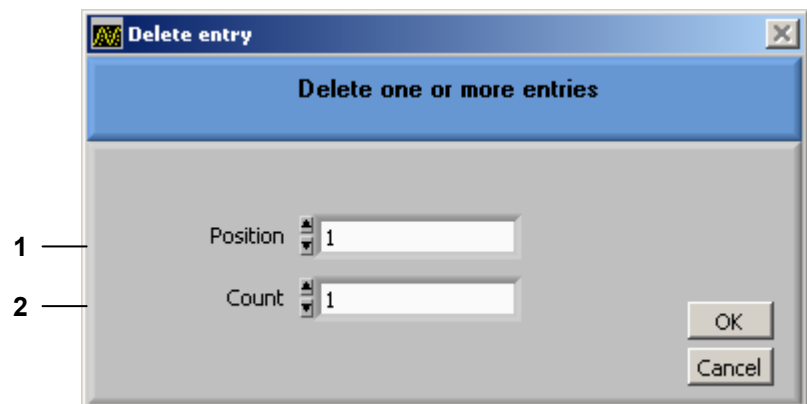

Function



Open line delete menu:
Deleting a list entry

- (1) Entering the line number of the list entry to be deleted
- (2) Entering the number of list entries to be deleted

7.6.3 ? Help

Pull down menu

H elp	Start help function
I no Ctrl+I	Display program information
S ervice	Display module data and perform selftests

8 Instrument Interfaces

This chapter The chapter 8 contains a description of the R&S SM300's interfaces.

Further information The address of our Support Center and a list of Rohde & Schwarz service centers will be found at the front of this manual.

8.1 Keyboard Connector (KEYB)

Connector There is a 6-pin PS/2 connector KEYB [25] on the R&S SM300's rear panel for an external keyboard.

Pin assignment	Pin	Signal
	1	KEYBOARDDATA
	2	MOUSEDATA
	3	GND
	4	5V, KEYBOARD
	5	KEYBOARDCLK
	6	MOUSECLK

8.2 Monitor Connector (MON)

Connector There is connector MON [24] on the rear panel of the R&S SM300 for an external monitor.

Pin assignment	Pin	Signal
	1	R
	2	G
	3	B
	4	(NC)
	5	GND
	6	GND
	7	GND
	8	GND
	9	GND
	10	GND
	11	(NC)
	12	(NC)
	13	HSYNC
	14	VSYNC
	15	(NC)

8.3 Reference Input and Output (EXT REF IN, REF OUT)

External reference	If an external reference is used, the internal reference oscillator is synchronized to the 10 MHz reference signal at connector EXT REF IN [26]. The input level must be 0.5 to 2V.
Internal reference	The 10 MHz signal from the internal reference oscillator is available at the REF OUT connector [27] so that other devices can be synchronized to the R&S SM300. The output level is 0 dBm.
Instrument setting	You can switch over between the internal and external reference in the CONFIG menu (➔ 6-177).

8.4 USB Interface (PC, DEV)

Connector The USB-Host [19] and USB-Device [20] connectors on the rear panel of the R&S SM300 are for a USB device.

Pin assignment



Pin	Signal
1	Vbus (Vcc)
2	D-
3	D+
4	GND
Shell	Shield

9 Error Messages

This chapter Refer to chapter 9 for a detailed description of errors that may occur in the R&S SM300. You will also find notes on troubleshooting.

Further information Chapter 6 describes all the R&S SM300's menus and the associated functions in detail.

9.1 System Messages

System messages System messages inform you of internally detected errors. The following informs are displayed, e. g.:

- Type of error (**x**)
- Four-digit error number (**y**)
- Request for closing the system messages (**z**)



The error number allows the service shop to determine the type of error. In the event of an system message, please write down the error number and proceed according to the following steps.

**Device Error
"Error number"**

A system error was detected in the instrument.

1. Please write down the error number and the corresponding instrument settings.
2. Contact your nearest Rohde & Schwarz representative (0-34). The instrument may have to be checked in the service shop.

**Overtemperature
Error
"Error number"**

An impermissibly high temperature was detected in the instrument. The internal fans are switched to full power for approx. 30 seconds, and then the R&S SM300 is automatically switched off to prevent further overheating.

The overtemperature could be caused by too high an ambient temperature and/or reduced air circulation.

1. Let the instrument cool off for a while and remove any obstructions that could hinder air circulation.
2. If this doesn't eliminate the overtemperature, have the instrument checked by the service shop.

NOTE

Some errors can cause the instrument or parts of the instrument to be switched off immediately in order to avoid destruction of components. Whenever an system message occurs, an entry is made under SYSTEM MESSAGES (↗ 6-187).

9.2 Warnings Indicating Impermissible Operating States

Warnings

Red labels at the upper left corner tell the user that the measurement results may be incorrect. The warning remains on the screen until the problem has been eliminated.

There are following messages that can be displayed on the screen:



PLL unlock

PLL unlock

The control loop, which is used to set the frequency of the internal reference oscillator with crystal accuracy, does not lock. This causes a frequency error, and the signal generator no longer operates according to specifications. The cause for this may be an internal instrument error or the absence of the 10 MHz reference signal at the external input REF IN. The absence of the reference signal, however, is not indicated unless the reference has been switched to "external".

1. If the missing external reference signal is the cause of this error message, connect a 10 MHz signal to the REF IN [26] input or switch the reference to "internal" (↗ 6-177).
2. If the missing external reference signal is not the cause of this error message, an internal instrument error has occurred. In this case, switch the R&S SM300 off and on again. If the error message is still present, the instrument must be sent to the service shop to be checked.

10 Index

- μ**
- μs (Unit keys)..... 5-48
- 0**
- 0 ... 9 (Numerical keys)..... 5-48
- A**
- AC line
 - Connection 3-41
 - Voltage 3-41
 - AC line fuse 2-38
 - AC line switch 2-38
 - AC supply
 - Connector 2-38
 - Fuse 2-38
 - Switch 2-38
 - Action keys 5-50
 - AM
 - coupling 6-84
 - Modulation depth 6-82
 - modulation source 6-84
 - Polarity of modulation voltage 6-97
 - Polarity of the modulation voltage 6-83
 - Switching on/off 6-85
 - Amplitude modulation See AM
 - Assignment see function area
- C**
- Call up
 - Setting area 7-215
 - Configuration (program)..... 7-190
 - Connecting
 - External keyboard 3-44
 - Connection
 - External monitor 6-183
 - Connection (USB)..... 7-194, 7-198, 7-206
 - Connector
 - External keyboard 8-237
 - External monitor 8-237
 - For AC supply 2-38
 - For external keyboard 2-38, 6-149
 - For external monitor 2-38
 - For external USB device 2-38
 - For external USB host 2-38
 - Control (program) 7-212
 - Control elements 2-37
 - Correction
 - Level 6-137
 - Coupling
 - AM 6-84
 - FM 6-89
 - Create (Program)..... 7-201
 - Cursor keys 2-37
 - Description 5-49
 - Parameter entry 5-60
- D**
- Date 6-175
 - Decimal point (Numerical keys)..... 5-48
 - Defaults
 - Instrument settings 6-71
 - Deleting
 - A channel list 6-131
 - A correction list 6-146
 - A list entry 6-129, 6-144, 6-158
 - A sequence list 6-160
 - Device Drivers
 - Windows™ 2000 7-194
 - Windows™ XP 7-198
 - Device Error (System messages) 9-239
 - Diagram display 7-213
 - Display
 - Converting the level/voltage 6-136
 - Instrument settings 6-167
 - LF frequency 6-73, 6-76, 6-77
 - LF level 6-73, 6-76, 6-77
 - RF frequency 6-73
 - RF level 6-73
 - Statistics 6-186
 - Window 7-212
 - Display window 5-52
 - Dwell time
 - LF frequency sweep 6-114
 - RF frequency sweep 6-103
 - RF level sweep 6-108
- E**
- Editing
 - List entry 6-124, 6-140, 6-154
 - EMC 3-43
 - ENTER (Action key) 2-37, 5-50
 - Entry See Parameter entry
 - Entry of
 - Channel list 6-122
 - Correction list 6-138
 - LF frequency 6-77, 6-85, 6-90, 6-93
 - LF level 6-77
 - Sequence list 6-152
 - Error messages 9-239
 - ESC/CANCEL (Action key) 5-50
 - ESC/CANCEL (Action key) 2-37
 - Exit (program) 7-209
- F**
- Factory default settings
 - Instrument 6-71
 - FM
 - Coupling 6-89
 - Frequency deviation 6-87
 - Modulation source 6-89
 - Polarity of the modulation voltage 6-88
 - Switching on/off 6-90

- Frequency
 - Holding the current setting 6-133
 - LF frequency sweep 6-112
 - LF output 6-78
 - Offset 6-118
 - RF frequency sweep 6-101
 - RF output 6-75
 - Setting (example) 4-46
- Frequency (Data sheet) 0-11
- Frequency deviation
 - FM 6-87
- Frequency entry
 - Step size 6-119
- Frequency modulation See FM
- Function
 - Display 7-214
- Function area, assignment 5-53
- Function keys 2-37
 - Assignment 5-62
 - Description 5-49, 5-53
- Function test 3-42
- Functions (overview) 7-216
- Fuse 2-38

- G**
- General data (Data sheet) 0-16
- GHz (Unit keys) 5-48

- H**
- Handle 3-39
- Hz (Unit keys) 5-48

- I**
- I signal, external 2-38, 6-98
- Input
 - External I signal 2-38
 - External modulation signal 2-38
 - External pulse signal 2-38
 - External Q signal 2-38
 - External reference 2-38, 6-177, 8-238
- Inputs (Data sheet) 0-14
- Inserting
 - List entry 6-124, 6-140, 6-154
- Install (program) 7-190
- Instrument
 - Functions (overview) 7-216
 - USB connection 7-194, 7-198, 7-206
- Instrument default setting
 - Loading 6-166
- Instrument functions 5-62
- Instrument interfaces 6-179
- Instrument interfaces (Interfaces) 8-237
- Instrument setting
 - Loading 6-79, 6-149
 - PRESET 6-79
 - Saving 6-149
- Instrument settings
 - Defaults 6-71
 - Displaying 6-167
 - Loading 6-169
 - PRESET 6-165
- Saving 6-169
- User-defined 6-168
- Interface
 - USB 0-15, 2-38, 8-238
- Interface (Data sheet) 0-15

- K**
- Key assignment
 - Function keys 5-62
- Keyboard, external 2-38, 3-44, 6-149, 8-237
- kHz (Unit keys) 5-48

- L**
- Level
 - Correction
 - Manual 6-137
 - Switching on/off 6-147
 - LF output 6-78
 - Offset 6-135
 - RF level sweep 6-107
 - RF output 6-75
 - Setting (example) 4-46
- Level entry
 - Step size 6-136
- LF
 - Displaying the frequency 6-77
 - Displaying the level 6-77
 - Entering the frequency 6-77, 6-85, 6-90, 6-93
 - Entering the level 6-77
 - Generator (Data sheet) 0-12
 - Output 2-37
 - Switching on the output 6-78
- Line fuse 2-38
- List
 - Channel list
 - Channel number 6-132
 - Creating/editing 6-122
 - Deleting 6-131
 - Deleting an entry 6-129
 - Inserting/editing an entry 6-124
 - Correction list
 - Creating/editing 6-138
 - Deleting 6-146
 - Deleting an entry 6-144
 - Inserting/editing an entry 6-140
 - Sequence list
 - Creating editing 6-152
 - Deleting 6-160
 - Deleting an entry 6-158
 - Inserting/editing an entry 6-154

- M**
- Measurement
 - Exit 7-209
- Measuring example
 - Remote control 7-210
- Menu
 - Calling and changing 5-54
 - CONFIG 5-69
 - Display 7-213
 - FILE 5-69

FREQ CHAN..... 5-66, 6-117
 LEVEL 5-67, 6-134
 MAIN..... 5-62, 6-73
 MOD 5-63, 6-80
 Overview..... 5-62
 PRESET 5-69
 SEQUENCE 5-68
 SEQUENCE 6-148
 SERVICE 5-69, 5-70
 STATUS 5-69
 SWEEP..... 5-65, 6-99
 Menu area 5-53
 Menus (overview)
 File (pull down) 7-216
 Function (pull down) 7-216
 Help (pull down)..... 7-236
 MHz (Unit keys) 5-48
 Minus sign (Numerical keys)..... 5-48
 Model designation..... 6-186
 Modulation
 AM 6-81
 FM 6-86
 I/Q 6-98
 PULSE MOD..... 6-94
 Switching on 6-78
 ϕ M 6-91
 Modulation (Data sheet) 0-12
 Modulation signal, external 2-38, 6-84
 Modulation source
 AM 6-84
 FM 6-89
 PULSE MOD..... 6-96
 Monitor, external 2-38, 6-183, 8-237
 ms (Unit keys)..... 5-48

N

Numerical keys 2-37
 Description..... 5-48
 Parameter entry 5-58

O

Offset
 Frequency..... 6-118
 Level 6-135
 ON 2-37, 3-42
 Operating hours 6-186
 Operating mode
 Signal generator 6-72
 System settings 6-163
 Operation
 Manual 5-48
 Output
 Internal/external reference 6-177, 8-238
 LF 2-37, 6-78
 RF 2-37, 6-75
 Output for internal/external reference 2-38
 Outputs (Data sheet) 0-15
 Overtemperature error (System messages) 9-239
 Overview
 Functions 7-216
 Menus 7-216
 Shortcuts 7-216

P

Parameter entry
 Direct 5-56
 Numerical entry 5-58
 Selection 5-57
 Parameters, entering
 Toggling a setting 5-56
 PC
 System requirements..... 7-190
 USB connection..... 7-194, 7-198, 7-206
 PC Monitor
 Display..... 7-212
 PC software See program
 Phase deviation
 ϕ M 6-92
 Phase modulation..... See ϕ M
 PLL unlock (warnings) 9-240
 Polarity of modulation voltage
 AM 6-97
 Polarity of the modulation voltage
 AM 6-83
 FM 6-88
 Power supply (Data sheet) 0-16
 Power-on cycles 6-186
 Preset 6-79, 6-165
 Program
 Control 7-212
 Create 7-201
 Exit 7-209
 Install 7-190
 Start 7-207
 Uninstall..... 7-203
 update 7-204
 PULSE MOD
 Modulation source 6-96
 Pulse delay time 6-96
 Pulse off time 6-95
 Pulse on time 6-95
 Switching on/off 6-97
 Pulse modulation See PULSE MOD
 Pulse signal, external 2-38
 Putting into operation 3-39

Q

Q signal, external 2-38, 6-98

R

Reference
 External 2-38, 8-238
 Internal 2-38, 8-238
 Reference source
 External 6-177
 Internal 6-177
 Remote control
 Freq/Chan 7-227
 Level 7-230
 Main 7-217
 Modulation 7-218
 Sequence 7-233
 Sweep 7-223
 Reset 6-165

- RF
 Level (Data sheet) 0-11
 Output 2-37
 Switching the output on 6-75
Rotary knob 2-37
 Description 5-49
 Parameter entry 5-60
 Step size 6-119, 6-136
- S**
- s (Unit keys) 5-48
Safety Instructions 0-17
Screen 2-37
 Layout 5-51
Screen saver 6-181
Selftests 6-184
Sequence
 Creating a sequence 6-151
 Setting/starting the sequence mode 6-161
Service Manager Series 300
 start 7-201
Setting (example)
 Frequency 4-46
 Level 4-46
Setting area
 Call up 7-215
Setting lever 3-39
Setting up the Instrument 3-39
Shortcuts (overview) 7-216
SM300 (USB connection) 7-194, 7-198, 7-206
Spacing
 LF frequency sweep 6-113
 RF frequency sweep 6-102
STANDBY 2-37, 3-42
Start
 Program 7-207
Start (Service Manager Series 300) 7-201
Start frequency
 LF frequency sweep 6-112
 RF frequency sweep 6-101
Start level
 RF level sweep 6-107
Step size
 Frequency entry 6-119
 Level entry 6-136
 LF frequency sweep 6-113
 RF frequency sweep 6-102
 RF level sweep 6-108
Stock number 6-186
Stop frequency
 LF frequency sweep 6-112
 RF frequency sweep 6-101
Stop level
 RF level sweep 6-107
Sweep
 LF frequency sweep
 Frequency range 6-112
 Sweep mode 6-115
 Sweep sequence 6-113
 RF frequency sweep
 Frequency range 6-101
 Sweep mode 6-104
 Sweep sequence 6-102
 RF level sweep
 Level range 6-107
 Sweep mode 6-109
 Sweep sequence 6-108
 Sweep (Data sheet) 0-14
Switching on
 LF output 6-77
Switching on/off
 AM 6-85
 FM 6-90
 Modulation, all 6-78
 PULSE MOD 6-97
SYS
 Key 5-50
 System functions 6-163
SYS key 2-37
System informations 6-185
System messages 9-239
 Device Error 9-239
 Overtemperature error 9-239
System requirements (PC) 7-190
- T**
- Time 6-175
- U**
- UCOR See Level correction
Uninstall (program) 7-203
Unit keys 2-37, 5-48
Update (Program) 7-204
USB connection 7-194, 7-198, 7-206
USB device, external 2-38
USB host, external 2-38, 8-238
USB stick 3-45
User correction See Level correction
- W**
- Warnings 9-240
 PLL unlock 9-240
Window
 Display 7-212
- Φ**
- φM
 Phase deviation 6-92