

Manual

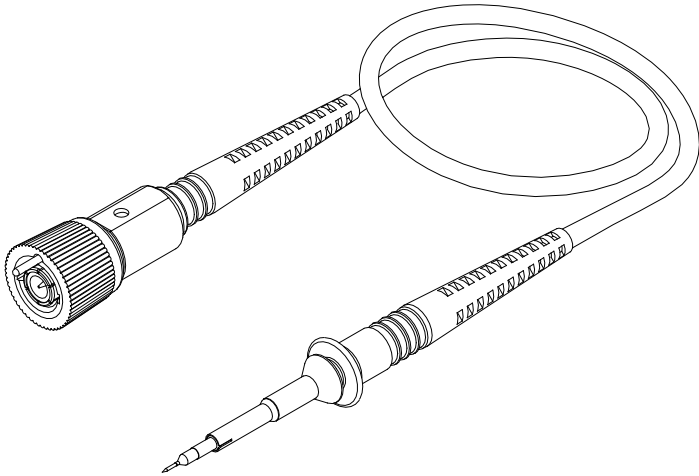

700 MHz Passive Voltage Probe

R&S[®] RT-ZP11

1803.0005.02

Printed in Germany

ROHDE & SCHWARZ

Make ideas real



ROHDE & SCHWARZ

For comprehensive information about Rohde and Schwarz, please visit our homepage on the R&S Internet (<http://www.rohde-schwarz.com>).

For queries regarding technical aspects of our products, please contact our customer support at <http://www.customersupport.rohde-schwarz.com>.

For international services, please contact our service partners at <http://www.service.rohde-schwarz.com>.

For additional questions, please contact our headquarters in Munich.

ROHDE & SCHWARZ GmbH & Co. KG

Mühlendorfstraße 15

D-81671 München

Phone: +49 (89) 41 29 - 0

Fax: +49 (89) 41 29 - 12 164

Declaration of Conformity



The manufacturer declares the conformity of this product with the actual required safety standards in accordance with the Low Voltage Directive (LVD) 2014/35/EU:

CE/IEC 61010-031:2015

Safety requirements for electrical equipment for measurement, control and laboratory use -

Part 031:

Safety requirements for hand-held probe assemblies for electrical measurement and test

WEEE/ RoHS Directives



This electronic product is classified within the WEEE/ RoHS category list as monitoring and control equipment (category 9) and is compliant to the following EC Directives.

EC Directives:

WEEE Directive 2012/19/EU

- Waste Electrical and Electronic Equipment

RoHS Directive 2011/65/EU

- Restriction of the use of certain Hazardous Substances in Electrical and Electronic Equipment

Your help and efforts are required to protect and keep clean our environment. Therefore return this electronic product at the end of its life either to our Service Department or take care of separate WEEE collection and professional WEEE treatment yourself. Do not dispose as unsorted municipal waste.

To avoid personal injury and to prevent fire or damage to this product or products connected to it, review and comply with the following safety precautions. Be aware that if you use this probe assembly in a manner not specified the protection this product provides may be impaired.

Only qualified personnel should use this probe assembly.

Use only grounded instruments.

Do not connect the probe ground lead to a potential other than earth ground. Always make sure the probe and the measurement instrument are grounded properly.

Connect and disconnect properly.

Connect the probe output to the measurement instrument and connect the ground lead to earth ground before connecting the probe to the circuit under test. Disconnect the probe input and the probe ground lead from the circuit under test before disconnecting the probe from the measurement instrument.

Observe probe and probe accessory ratings.

Do not apply any electrical potential to the probe input which exceeds the maximum ratings of the probe or the accessories connected to it. In a combination always the *lower* rating / measurement category applies to both probe and accessories connected to it.

Make sure to comply with the voltage versus frequency derating curve on page 8.

Keep away from live circuits.

Avoid open circuitry. Do not touch connections or components when power is present.

Do not operate with suspected failures.

Refer to qualified service personnel.

Indoor use only.

Do not operate in wet/damp environment. Keep product surfaces dry and clean.

Do not operate the product in an explosive atmosphere.

IEC Safety Symbols

The following symbols may appear on the product or in this instruction manual:



Caution, risk of danger. Refer to manual.



Caution, risk of electric shock.



Earth (ground) TERMINAL.

Definitions and Examples

No Measurement Category not in CAT II, III or IV	Definition:	Many types of test and measuring circuits are not intended to be directly connected to the mains supply. Some of these measuring circuits are intended for very low energy applications, but others of these measuring circuits may experience very high amounts of available energy because of high short-circuit currents or high open-circuit voltages. There are no standard transient levels defined for these circuits. An analysis of the WORKING VOLTAGES, loop impedances, temporary overvoltages, and transient overvoltages in these circuits is necessary to determine the insulation requirements and short-circuit current requirements.
	Examples:	Thermocouple measuring circuits, high-frequency measuring circuits, automotive testers, and testers used to characterize the mains installation before the installation is connected to the mains supply.
Measurement Category II CAT II	Definition:	MEASUREMENT CATEGORY II is applicable to test and measuring circuits connected directly to utilization points (socket outlets and similar points) of the low-voltage mains installation
	Examples:	Measurements on MAINS CIRCUITS of household appliances, portable tools and similar equipment, and on the consumer side only of socket-outlets in the fixed installation.
Measurement Category III CAT III	Definition:	MEASUREMENT CATEGORY III is applicable to test and measuring circuits connected to the distribution part of the building's low-voltage mains installation. To avoid risks caused by the HAZARDS arising from these higher short-circuit currents, additional insulation and other provisions are required.
	Examples:	Measurements on distribution boards (including secondary meters), photovoltaic panels, circuitbreakers, wiring, including cables, bus-bars, junction boxes, switches, socket-outlets in the fixed installation, and equipment for industrial use and some other equipment such as stationary motors with permanent connection to the fixed installation.
Measurement Category IV CAT IV	Definition:	MEASUREMENT CATEGORY IV is applicable to test and measuring circuits connected at the source of the building's low-voltage mains installation. Due to these high short-circuit currents which can be followed by a high energy level, measurements made within these locations are extremely dangerous. Great precautions shall be made to avoid any chance of a short circuit.
	Examples:	Measurements on devices installed before the main fuse or circuit breaker in the building installation.

Definitions and Examples

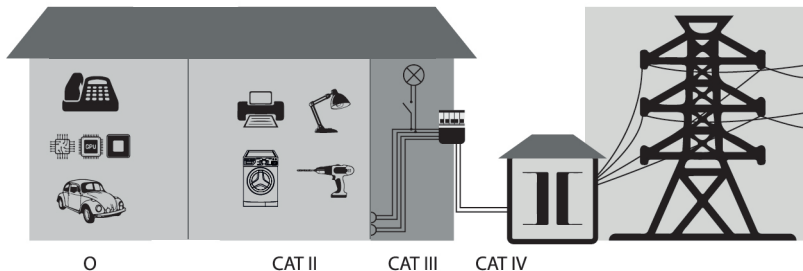

Overview of measurement categories according to IEC 61010-031

O = No Measurement Category (Other circuits that are not directly connected to mains)

IEC Pollution Degrees

Pollution Degree 1

No POLLUTION or only dry, non conductive POLLUTION.
NOTE: The POLLUTION has no influence.

Pollution Degree 2

Only- non conductive POLLUTION. Occasionally, however, a temporary conductivity caused by condensation must be accepted.

Pollution Degree 3

Conductive POLLUTION occurs or dry, non-conductive POLLUTION occurs which becomes conductive due to condensation which is to be expected.

Specifications that are not defined to be guaranteed are typical and are published as general information to the user. The instrument should have warmed-up for at least 20 minutes and the environmental conditions do not exceed the probe's specified limits.

Electrical Specifications

Attenuation Ratio ⁽¹⁾	10:1	± 2 % at DC	(warranted)
Voltage Coefficient	0.00025 %/V	at DC	
System Bandwidth	700 MHz	(-3 dB)	
Probe Risetime	700 ps	(10 % - 90 %)	
Input Resistance (System)	10 MΩ	± 1 %	(warranted)
Input Capacitance (System)	9.5 pF		
Compensation Range	5 pF - 20 pF		
Input Coupling of the Measuring Instrument	1 MΩ AC / DC		

Maximum Rated Input Voltages, CAT II, CAT III ⁽²⁾

Pollution Degree	2
Measurement Category II:	300 V CAT II

Maximum Rated Input Voltages, No Measurement Category, not in CAT II, III, IV ⁽²⁾

Pollution Degree	2
No Measurement Category:	400 V

Maximum Pulse Rating, No Measurement Category, not in CAT II, III, IV

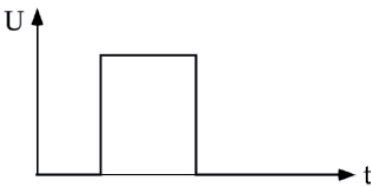

Voltage pulse

$U_{pulse}^{(3)} = 1650 \text{ V (Step 0 V to 1650 V)}$

(1) Connected to appropriate R&S oscilloscope. See R&S oscilloscope operating manual for further details.
 (2) As defined in IEC 61010-031. See definitions explained on page 4 and 5.
 (3) No overshoot permitted

Voltage Derating



Note that the max. input voltage rating of the probe decreases as the frequency of the applied signal increases.

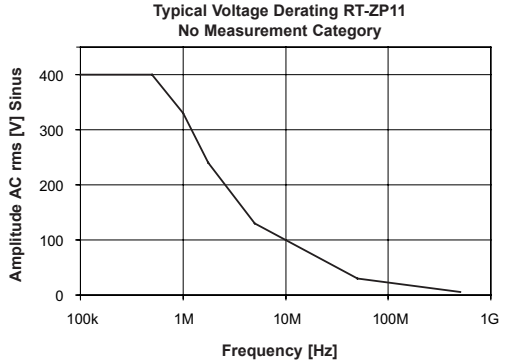

Input Impedance



Note that the input impedance of the probe decreases as the frequency of the applied signal increases.

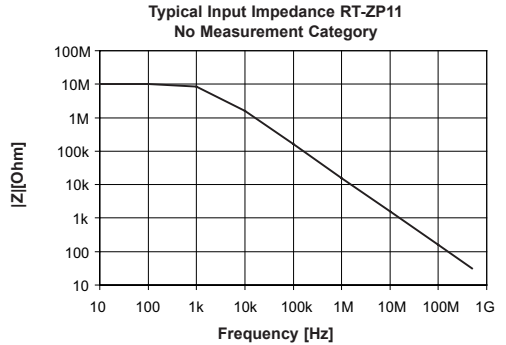

Mechanical Specifications

Weight (probe only)	48 g
Cable Length	1.3 m
Probe Tip Diameter	2.5 mm

Environmental Specifications

Altitude	operating	up to 2000 m
	non-operating	up to 15000 m
Temperature Range	operating	0° C to +50° C
	non-operating	-40° C to +71° C
Maximum Relative Humidity	operating	80 % relative humidity for temperatures up to +31° C, decreasing linearly to 40 % at +50° C

The probe can be adjusted for low frequency (LF) compensation and for high frequency (HF) compensation.

LF Compensation

LF needs to be adjusted when the probe is connected to the oscilloscope input the first time. LF compensation matches the probes cable capacitance to the oscilloscope input capacitance. This matching assures good amplitude accuracy from DC to upper bandwidth limit frequencies. A poorly compensated probe clearly influences the overall system performance (probe + scope) and introduces measurement errors resulting in inaccurate readings and distorted waveforms.

LF compensation is performed by connecting the probe to the PROBE COMPENSATION output on the oscilloscope front panel and adjusting the LF compensation trimmer to optimum square wave response. For clarification see below figures.

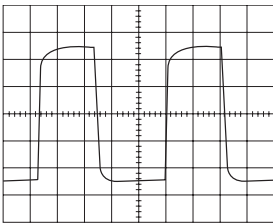

undercompensated

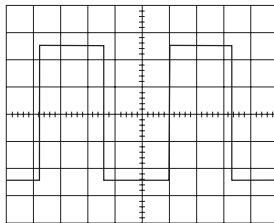

optimum

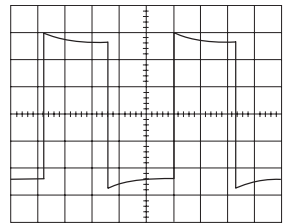

overcompensated

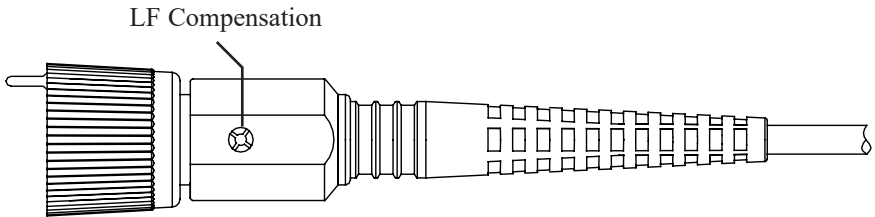

HF Compensation

It is typically not necessary to adjust HF compensation unless the probe is being used with an oscilloscope having large differences in input characteristics to the oscilloscope that was used for factory adjustment.

We recommend to use the following equipment for proper HF compensation:

Rectangular wave generator with a rise time faster than 700 ps, 50 Ohm feed-through and probe BNC adapter.

HF adjustment is performed by connecting the probe to the rectangular wave generator. Adjust trimmers (T_1 and T_2) for optimum square wave response.

T_1 is used for rise time adjustment.
 T_2 influences probe response time.

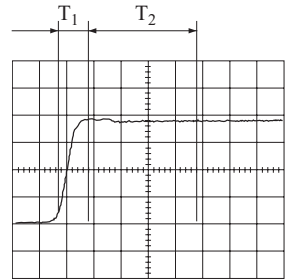

optimum

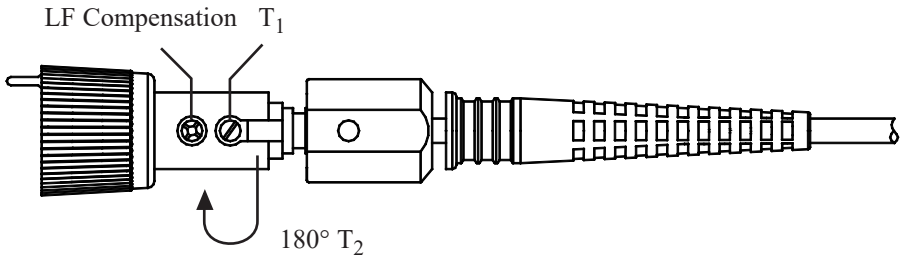

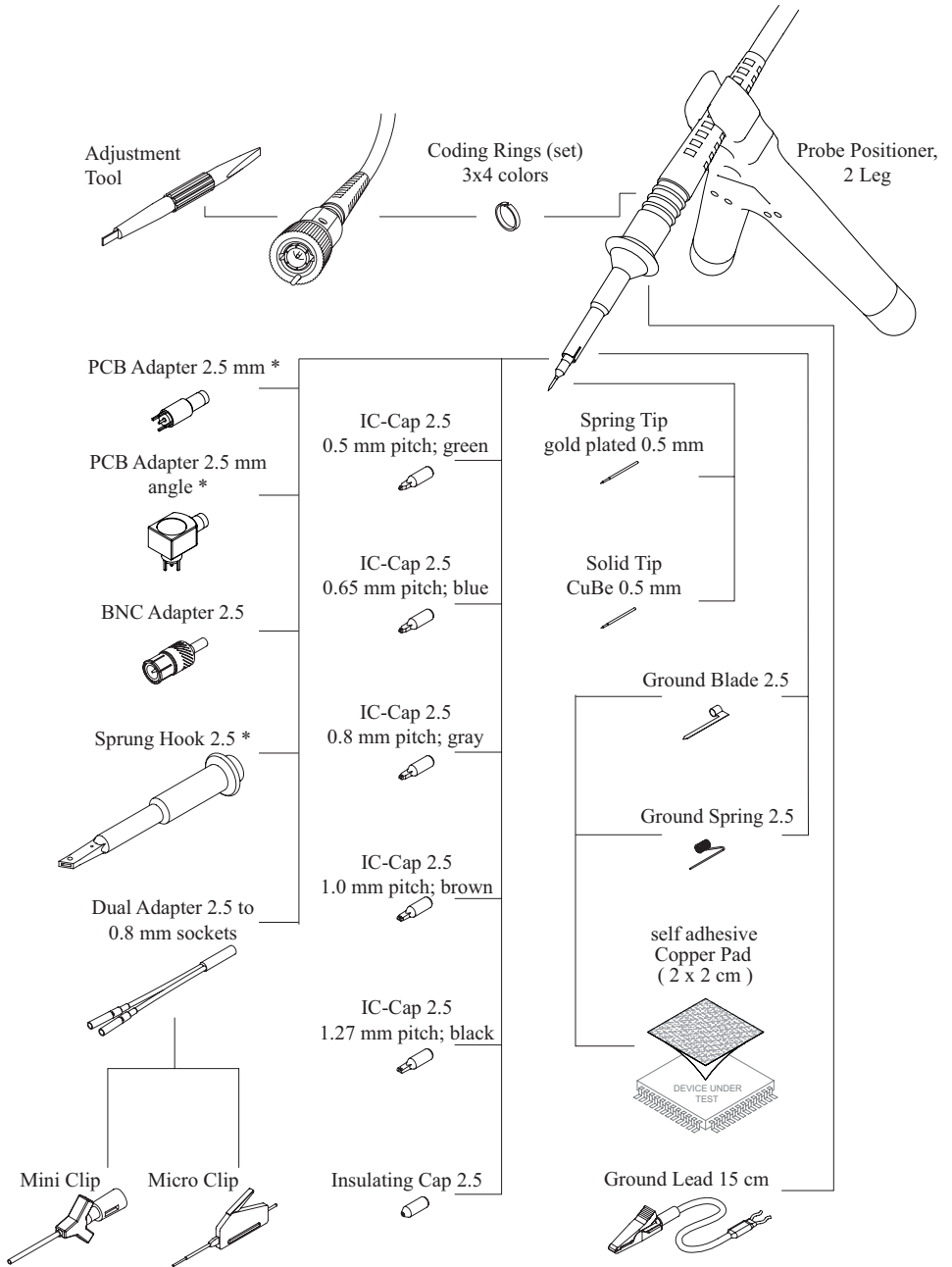

* See ratings for these accessories on page 11

In a combination always the lower rating / measurement category applies to both probe and accessories connected to it.

Sprung Hook 2.5

Maximum Rated Input Voltages, CAT II ⁽¹⁾

Pollution Degree 2
 Measurement Category II: 300 V CAT II

Maximum Rated Input Voltages, No Measurement Category, not in CAT II, III, IV ⁽¹⁾

Pollution Degree 2
 No Measurement Category: 400 V / 1650 V peak

Maximum Pulse Rating, No Measurement Category, not in CAT II, III, IV ⁽¹⁾

$U_{pulse}^{(2)} = 1650 \text{ V}$ (Step 0 V to 1650 V)

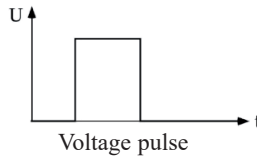

PCB Adapter 2.5 mm / PCB Adapter 2.5 mm angle

Maximum Rated Input Voltages, No Measurement Category, not in CAT II, III, IV ⁽¹⁾

Pollution Degree 2
 No Measurement Category: 250 V DC or AC peak

Maximum Pulse Rating, No Measurement Category, not in CAT II, III, IV ⁽¹⁾

$U_{pulse}^{(2)} = 1600 \text{ V}$ (Step 0 V to 1600 V)

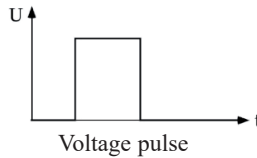

Drilling / soldering template



The minimum distance between all solder pads of 1.25 mm (see adjacent template) must not be undercut under any circumstances. Undercutting this distance will void the rating

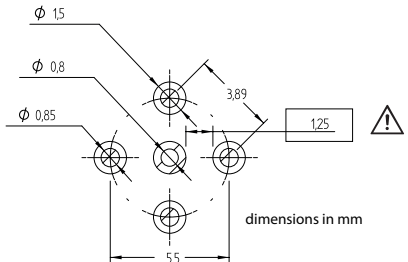

(1) As defined in IEC 61010-031. See definitions explained on page 4 and 5.
 (2) No overshoot permitted

The following items are included in the scope of delivery. Please check the delivery for completeness.

RT-ZP11 700 MHz passive voltage probe (Order No. 1803.0005.02)

Item	Qty
Adjustment Tool	1
Coding Rings (set) 3x4 Colors	1
Ground Lead 15 cm	1
Ground Spring 2.5	1
Operating Manual	1
Probe	1
Solid Tip CuBe 0.5 mm	1
Spring Tip gold plated 0.5 mm	1 ⁽¹⁾
Sprung Hook 2.5	1 ⁽²⁾

(1) installed in probe

(2) plugged on probe



Use ground lead only for connections to earth ground.

The following accessory sets can be ordered separately.

RT-ZA1	Accessory Kit (Order No. 1409.7566.02)	
	Item	Qty
	Adjustment Tool	1
	BNC Adapter 2.5	1
	Coding Rings (set) 3x4 Colors	1
	Copper Pad; self adhesive (2x2 cm)	2
	Dual Adapter 2.5 to 0.8 mm sockets	1
	Ground Blade 2.5	1
	Ground Lead 15 cm	1
	Ground Spring 2.5	5
	IC-Cap 2.5 0.5 mm pitch; green	1
	IC-Cap 2.5 0.65 mm pitch; blue	1
	IC-Cap 2.5 0.8 mm pitch; gray	1
	IC-Cap 2.5 1.0 mm pitch; brown	1
	IC-Cap 2.5 1.27 mm pitch; black	1
	Insulating Cap 2.5	1
	Solid Tip CuBe 0.5 mm	5
	Sprung Hook 2.5	1
	Spring Tip gold plated 0.5 mm	5
RT-ZA4	Mini Clips (Order No. 1416.0428.02)	
	Item	Qty
	Mini Clip	10
RT-ZA5	Micro Clips (Order No. 1416.0434.02)	
	Item	Qty
	Micro Clip	4
RT-ZA27	PCB Adapter 2.5 mm (Order No. 1801.4784.02)	
	Item	Qty
	PCB Adapter 2.5 mm	10
RT-ZA28	PCB Adapter 2.5 mm angle (Order No. 1801.4790.02)	
	Item	Qty
	PCB Adapter 2.5 mm angle	10
RT-ZA29	Probe Positioner, 2 Leg (Order No. 1801.4803.02)	
	Item	Qty
	Probe Positioner, 2 Leg	1



*The accessories provided with the probe have been safety tested.
Do not use any other accessories than those “originally” provided.*



Handle with care especially when fitted with the extra thin and sharp spring contact tip to avoid any injury. Note that the probe cable is a sensitive part of the probe. Do not damage through excessive bending or pulling. Avoid mechanical shock to this product in general to guarantee accurate performance and protection.

Cleaning

To clean the exterior of the probe use a soft cloth moistened with either distilled water or isopropyl alcohol. Before use allow the probe to dry completely.

Changing the Probe Tip

To change the probe tip use pliers to grip and pull it carefully straight out of its contact socket, along the axis of the probe. Do not grip the white plastic insulator or the housing with pliers, because the tip could be squeezed and cannot be removed and respectively the probe could be damaged.

If the probe tip is removed, the new tip can be inserted with pliers into the contact socket, along the axis of the probe. In order to insert the probe tip completely into the housing, press the probe tip against a hard surface carefully.

Most oscilloscopes provide a build-in function generator to verify the passive probe is compensated correctly. After changing the probe tip always use the build-in function generator or other stand-alone instrument to make sure the probe is safe to operate.

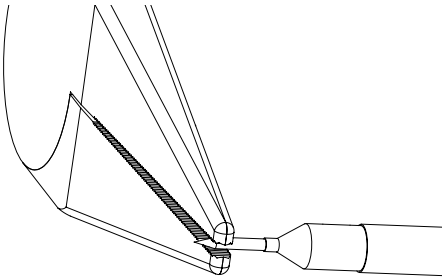

Use pliers to grip and pull the probe tip carefully out of its contact socket.

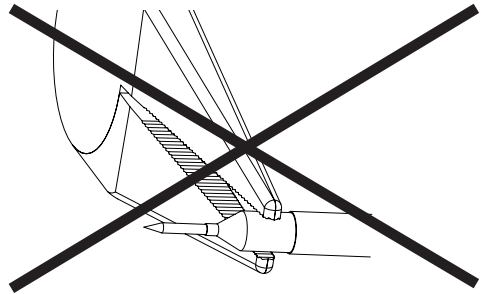

Do not grip the white plastic insulator or the probe housing with pliers.

Copyright®2021 ROHDE & SCHWARZ All rights reserved.

Information in this publication supersedes that in all previously published material.
Specifications are subject to change without notice.