

R&S®FSH4/8/13/20

Remote Control via LAN or USB

Software Manual



1173.0089.12 – 34

The Software Manual describes the following R&S®FSH options

- R&S FSH-K40 (1304.5606.02)

The contents are for R&S FSH models:

- R&S FSH4 (1309.6000.04)
- R&S FSH4 (1309.6000.14)
- R&S FSH4 (1309.6000.24)
- R&S FSH8 (1309.6000.08)
- R&S FSH8 (1309.6000.18)
- R&S FSH8 (1309.6000.28)
- R&S FSH13 (1314.2000.13)
- R&S FSH13 (1314.2000.23)
- R&S FSH20 (1314.2000.20)
- R&S FSH20 (1314.2000.30)
- R&S FSH4 (1309.6000.54, equivalent to 1309.6000.04)
- R&S FSH4 (1309.6000.64, equivalent to 1309.6000.14)
- R&S FSH4 (1309.6000.74, equivalent to 1309.6000.24)
- R&S FSH8 (1309.6000.58, equivalent to 1309.6000.08)
- R&S FSH8 (1309.6000.68, equivalent to 1309.6000.18)
- R&S FSH8 (1309.6000.78, equivalent to 1309.6000.28)
- R&S FSH13 (1314.2000.63, equivalent to 1314.2000.13)
- R&S FSH13 (1314.2000.73, equivalent to 1314.2000.23)
- R&S FSH20 (1314.2000.70, equivalent to 1314.2000.20)
- R&S FSH20 (1314.2000.80, equivalent to 1314.2000.30)

The manual also covers the following firmware options:

- R&S FSH-K10 (1304.5864.02)
- R&S FSH-K41 (1304.5612.02)
- R&S FSH-K42 (1309.5629.02)
- R&S FSH-K43 (1304.5635.02)
- R&S FSH-K44 (1309.5658.02)
- R&S FSH-K44(E) (1304.5758.02)
- R&S FSH-K45 (1309.5641.02)
- R&S FSH-K46 (1304.5729.02)
- R&S FSH-K46E (1304.5764.02)
- R&S FSH-K47 (1304.5787.02)
- R&S FSH-K47E (1304.5806.02)
- R&S FSH-K48 (1304.5887.02)
- R&S FSH-K48E (1304.5858.02)
- R&S FSH-K50 (1304.5735.02)
- R&S FSH-K50E (1304.5793.02)
- R&S FSH-K51 (1304.5812.02)
- R&S FSH-K51E (1304.5829.02)
- R&S FSH-K56 (1318.6100.02)

The contents of this manual correspond to firmware version 3.60 or higher.

© 2024 Rohde & Schwarz GmbH & Co. KG
Muehldorfstr. 15, 81671 Munich, Germany
Phone: +49 89 4129-0
E-mail: info@rohde-schwarz.com
Internet: <http://www.rohde-schwarz.com>

Subject to change – Data without tolerance limits is not binding.
R&S® is a registered trademark of Rohde & Schwarz GmbH & Co. KG.
Trade names are trademarks of the owners.

1173.0089.12 | Version 34 | R&S®FSH

Throughout this manual, products from Rohde & Schwarz are indicated without the ® symbol, e.g. R&S®FSH is indicated as R&S FSH.

Table of Contents

1	Introduction	11
2	Interfaces and Protocols	12
2.1	LAN Interface	13
2.2	USB Interface	13
2.3	Protocols	14
3	Setting Up the Remote Control Connection	16
3.1	Preparing for Remote Control	16
4	Instrument Model and Command Processing	17
4.1	Input Unit	17
4.2	Command Recognition	18
4.3	Data Base and Instrument Hardware	18
4.4	Status Reporting System	19
4.5	Output Unit	19
5	SCPI Command Structure and Syntax	20
5.1	Structure of a Command	20
5.1.1	Common Commands	20
5.1.2	Device-Specific Commands	21
5.1.2.1	Hierarchy	21
5.1.2.2	Multiple Keywords	21
5.1.2.3	Optional Keywords	22
5.1.2.4	Long and Short Form	22
5.1.2.5	Parameter	23
5.1.2.6	Special Characters	23
5.1.2.7	Numeric Suffix	24
5.1.3	Overview of Syntax Elements	25
5.2	Parameters	26
5.2.1	Numeric Values	26
5.2.2	Special Numeric Values	26
5.2.3	Boolean Parameters	27
5.2.4	Text	27

5.2.5	Strings	27
5.2.6	Block Data	28
5.3	Structure of a Program Message	29
5.4	Responses to Queries	30
6	Command Sequence and Command Synchronization	31
7	Remote Control – Commands	32
7.1	Common Commands	33
7.2	Remote Commands of the Spectrum Analyzer	36
7.2.1	Configuring the Horizontal Axis	37
7.2.2	Configuring the Vertical Axis	42
7.2.3	Setting the Bandwidths	49
7.2.4	Performing and Triggering Measurements	51
7.2.4.1	Performing the Measurement	51
7.2.4.2	Capturing I/Q Data	54
7.2.4.3	Triggering Measurements	56
7.2.5	Working with Traces	60
7.2.6	Using Markers	66
7.2.6.1	Markers and Delta Markers	66
7.2.6.2	Marker Functions	74
7.2.7	Using Display Lines and Limit Lines	82
7.2.7.1	Display Lines	82
7.2.7.2	Limit Lines	83
7.2.8	Configuring and Using Measurement Functions	88
7.2.8.1	Working with Channel Tables	88
7.2.8.2	Power Measurements	91
7.2.8.3	Measuring the Channel Power	95
7.2.8.4	Measuring the Occupied Bandwidth	96
7.2.8.5	TDMA Measurements	97
7.2.8.6	Measuring the Adjacent Channel Leakage Ratio	98
7.2.8.7	Measuring the Harmonic Distortion	110
7.2.8.8	Measuring the AM Modulation Depth	112
7.2.8.9	Measuring the Spectrum Emission Mask	113
7.2.8.10	Measuring Spurious Emissions	115

7.2.8.11	Using the Segmented Sweep	116
7.2.8.12	Using an Isotropic Antenna.....	117
7.3	Remote Commands of the Network Analyzer Mode	119
7.3.1	Configuring the Horizontal Axis	119
7.3.2	Configuring the Vertical Axis.....	120
7.3.3	Configuring the Tracking Generator	128
7.3.4	Setting the Bandwidths	131
7.3.5	Performing and Triggering the Measurement.....	131
7.3.6	Working with Traces	132
7.3.7	Using Markers and Deltamarkers	134
7.3.7.1	Markers and Deltamarkers	134
7.3.7.2	Marker Functions	135
7.3.8	Configuring the Measurement	138
7.3.8.1	Selecting the Measurement Port	138
7.3.8.2	Selecting the Measurement Mode.....	139
7.3.8.3	Calibrating the Measurement.....	139
7.3.8.4	Selecting the Result Display	141
7.3.8.5	Selecting the Measurement Format.....	142
7.3.8.6	Configuring the Vector Voltmeter (option R&S FSH-K45).....	145
7.4	Remote Commands of the Power Meter.....	148
7.4.1	Using Power Sensors	148
7.4.1.1	Setting the Frequency.....	148
7.4.1.2	Configuring Power Level Readout.....	149
7.4.1.3	Defining the Measurement Time.....	151
7.4.1.4	Zeroing of the Power Sensor	152
7.4.1.5	Forward Power Display.....	152
7.4.1.6	Defining the Video Bandwidth.....	153
7.4.1.7	Reading Out Measurement Results.....	153
7.4.1.8	Selecting a Telecommunication Standard	154
7.5	Remote Commands of the Distance-to-Fault Mode	156
7.5.1	Configuring the Horizontal Axis	157
7.5.2	Configuring the Vertical Axis.....	158
7.5.3	Configuring the Tracking Generator	158

7.5.4	Setting the Bandwidth	158
7.5.5	Performing and Triggering Measurements	159
7.5.5.1	Performing the Measurement	159
7.5.6	Working with Traces	160
7.5.7	Using Markers.....	162
7.5.8	Using Limit Lines.....	163
7.5.9	Configuring and Using Measurement Functions	164
7.5.9.1	Selecting the Cable Characteristics.....	164
7.5.9.2	Selecting the Measurement Mode.....	165
7.5.9.3	Reading Out Measurement Results.....	165
7.5.9.4	Calibrating the Measurement.....	166
7.5.9.5	Working with a DTF List.....	168
7.6	Remote Commands of the Receiver Mode.....	171
7.6.1	Configuring the Horizontal Axis	172
7.6.2	Configuring the Vertical Axis.....	174
7.6.3	Setting the Bandwidth	175
7.6.4	Performing and Triggering the Measurement.....	176
7.6.4.1	Performing the Measurement	176
7.6.4.2	Triggering Measurements.....	176
7.6.4.3	Using an Isotropic Antenna.....	177
7.6.5	Working with Traces	178
7.6.6	Using Markers.....	180
7.6.6.1	Markers and Delta Markers	180
7.6.6.2	Marker Functions	180
7.6.7	Using Limit Lines.....	181
7.7	Remote Commands of the Digital Modulation Analyzer.....	182
7.7.1	Performing Measurements on GSM Signals	183
7.7.1.1	Setting the Frequency.....	183
7.7.1.2	Setting Amplitude Parameters	183
7.7.1.3	Setting the Bandwidths	184
7.7.1.4	Working with Traces	184
7.7.1.5	Performing and Triggering the Measurement.....	184
7.7.1.6	Using Markers.....	185

7.7.1.7	Working with Channel Tables	185
7.7.1.8	Selecting the Result Display	185
7.7.1.9	Configuring the Measurement	187
7.7.1.10	Getting Measurement Results	188
7.7.1.11	Analyzing Measurement Results	196
7.7.2	Performing Measurements on 3GPP WCDMA Signals	197
7.7.2.1	Setting the Frequency	197
7.7.2.2	Setting Amplitude Parameters	197
7.7.2.3	Setting the Bandwidths	198
7.7.2.4	Working with Traces	198
7.7.2.5	Performing and Triggering the Measurement	198
7.7.2.6	Using Markers	198
7.7.2.7	Working with Channel Tables	199
7.7.2.8	Selecting the Result Display	199
7.7.2.9	Configuring the Measurement	200
7.7.2.10	Determining Scrambling Codes	202
7.7.2.11	Performing a Channel Search	206
7.7.2.12	Using An Isotropic Antenna	206
7.7.2.13	Getting Measurement Results	206
7.7.2.14	Analyzing Measurement Results	209
7.7.2.15	Return Value Codes	210
7.7.3	Performing Measurements on CDMA2000 Signals	212
7.7.3.1	Setting the Frequency	212
7.7.3.2	Setting Amplitude Parameters	212
7.7.3.3	Setting the Bandwidths	213
7.7.3.4	Working with Traces	213
7.7.3.5	Performing and Triggering the Measurement	213
7.7.3.6	Using Markers	214
7.7.3.7	Working with Channel Tables	214
7.7.3.8	Selecting the Result Display	215
7.7.3.9	Configuring the Measurement	216
7.7.3.10	Getting Measurement Results	218
7.7.3.11	Return Value Codes	220

7.7.4	Performing Measurements on 1xEV-DO Signals	221
7.7.4.1	Setting the Frequency	221
7.7.4.2	Setting Amplitude Parameters	221
7.7.4.3	Setting the Bandwidths	222
7.7.4.4	Working with Traces	222
7.7.4.5	Performing and Triggering the Measurement	222
7.7.4.6	Using Markers	224
7.7.4.7	Working with Channel Tables	224
7.7.4.8	Selecting the Result Display	225
7.7.4.9	Configuring the Measurement	225
7.7.4.10	Getting Measurement Results	226
7.7.5	Performing Measurements on TD-SCDMA Signals	229
7.7.5.1	Setting the Frequency	229
7.7.5.2	Setting Amplitude Parameters	229
7.7.5.3	Setting the Bandwidths	230
7.7.5.4	Working with Traces	230
7.7.5.5	Performing and Triggering the Measurement	230
7.7.5.6	Using Markers	231
7.7.5.7	Working with Channel Tables	231
7.7.5.8	Selecting the Result Display	231
7.7.5.9	Configuring the Measurement	232
7.7.5.10	Getting Measurement Results	236
7.7.5.11	Return Value Codes	239
7.7.6	Performing Measurements on LTE Signals	240
7.7.6.1	Setting the Frequency	240
7.7.6.2	Setting Amplitude Parameters	242
7.7.6.3	Working with Traces	242
7.7.6.4	Performing and Triggering the Measurement	243
7.7.6.5	Selecting the Result Display	243
7.7.6.6	Configuring the Measurement	244
7.7.6.7	Using An Isotropic Antenna	251
7.7.6.8	Getting Measurement Results	251
7.7.6.9	Using the TRACe[:DATA] Command	260

7.7.7	Performing Measurements on NB-IoT Signals	263
7.7.7.1	Setting the Frequency	263
7.7.7.2	Setting Amplitude Parameters	263
7.7.7.3	Working with Traces	264
7.7.7.4	Performing and Triggering the Measurement	264
7.7.7.5	Selecting the Result Display	265
7.7.7.6	Configuring the Measurement	265
7.7.7.7	Getting Measurement Results	272
7.7.7.8	Using the TRACe[:DATA] Command.....	277
7.8	File Management.....	279
7.9	Making and Storing Screenshots.....	287
7.10	Configuring Data Capture	289
7.11	Saving Events	291
7.12	Configuring the Instrument	294
7.12.1	Mode Selection	294
7.12.2	Controlling the GPS Receiver	296
7.12.3	Controlling a Precision Frequency Reference (R&S FSH-Z114)	301
7.12.4	Display Configuration.....	303
7.12.5	Audio Settings.....	305
7.12.6	Setting up a Network Connection	307
7.12.7	System Settings	310
7.13	Status Reporting System	321
7.13.1	Structure of an SCPI Status Register	321
7.13.1.1	CONDition part.....	321
7.13.1.2	PTRansition part	322
7.13.1.3	NTRansition part.....	322
7.13.1.4	EVENT part	322
7.13.1.5	ENABLe part	322
7.13.1.6	Sum bit.....	323
7.13.2	Overview of the Status Register	323
7.13.3	Status Byte (STB) & Service Request Enable Register (SRE)	324
7.13.4	Event Status Register (ESR) and Event Status Enable Register (ESE)	325
7.13.4.1	STATus:OPERation Register	326

7.13.4.2	STATus:QUEStionable Register.....	326
7.13.4.3	STATus:QUEStionable:FREQuency Register	327
7.13.4.4	STATus:QUEStionable:LIMit Register	327
7.13.4.5	STATus:QUEStionable:POWer Register.....	327
7.13.5	Application of the Status Reporting Systems	328
7.13.5.1	Service Request.....	328
7.13.5.2	Serial Poll.....	328
7.13.5.3	Query by Means of Commands	329
7.13.5.4	Error Queue Query	329
7.13.6	Reset Values of the Status Reporting System	330
7.13.7	Remote Commands of the Status Reporting System.....	331

Documentation Overview

The user documentation for the R&S FSH is divided as follows:

Quick Start Guide

The Quick Start Guide provides basic information on the instrument's functions.

It covers the following topics:

- overview of all elements of the front and rear panels
- basic information on how to set up the R&S FSH
- information on how to operate the R&S FSH in a network
- instructions on how to perform measurements

Operating Manual

The Operating Manual provides a detailed description on the instrument's functions

It covers the following topics:

- instructions on how to set up and operate the R&S FSH in its various operating modes
- instructions on how to perform measurements with the R&S FSH
- instructions on how to work with the available software options and applications

Service Manual

The Service Manual provides information on maintenance.

It covers the following topics:

- instructions on how to perform a performance test
- instructions on how to repair the R&S FSH including a spare parts list
- mechanical drawings

Release Notes

The release notes describe the installation of the firmware, new and modified functions, eliminated problems, and last minute changes to the documentation. The corresponding firmware version is indicated on the title page of the release notes. The current release notes are provided on the internet.

Internet Site

The internet site at: <https://www.rohde-schwarz.com/product/fsh.html> provides the most up to date information on the R&S FSH. The most recent manuals are available as printable PDF files in the download area.

Also provided for download are firmware updates including the corresponding release notes, instrument drivers, current data sheets, application notes and image versions.

Calibration Certificate

The calibration certificates of your device are available online. Visit the R&S FSH product page and select the item to download the calibration certificate. You will be forwarded to a Gloris page.

<https://gloris.rohde-schwarz.com/calcert>

Enter the device ID of your R&S FSH and download the certificate. You can find the device ID either in the "Setup" menu or on the label on the rear panel.

1 Introduction

With the software application R&S FSH-K40 installed on the instrument, it is possible to operate your R&S FSH via remote control. In this manual you will find all information necessary to remotely control the R&S FSH.

Enabling the Option

The Remote Control Option R&S FSH-K40 is enabled by entering a key code. The key code is based on the unique serial number of the instrument. To retrofit an option, enable it with a key code.

- ▶ Press the SETUP key.
- ▶ Press the "Installed Options" softkey
- ▶ Select "Install Option..." under the "Option Administration" header.
- ▶ Confirm with ENTER.

An entry box in the lower right corner of the screen is displayed.

- ▶ Type in the the appropriate option key.
- ▶ Confirm with ENTER.

If the correct key code is entered, the R&S FSH displays

Installation successful !

If an invalid key code is entered, the R&S FSH displays

Invalid key code!

2 Interfaces and Protocols

The R&S FSH supports two different interfaces for remote control.

- **LAN Interface:** The protocol is based on TCP/IP and supports the VXI-11 standard.
- **USB Interface**

The connectors are located at the side of the instrument and permit a connection to a controller for remote control via a local area network (LAN) or directly via USB.

SCPI

SCPI (Standard Commands for Programmable Instruments) commands - messages - are used for remote control. Commands that are not taken from the SCPI standard follow the SCPI syntax rules. The instrument supports the SCPI version 1999. The SCPI standard is based on standard IEEE 488.2 and aims at the standardization of device-specific commands, error handling and the status registers. The tutorial "Automatic Measurement Control - A tutorial on SCPI and IEEE 488.2" from John M. Pieper (R&S order number 0002.3536.00) offers detailed information on concepts and definitions of SCPI.

The requirements that the SCPI standard places on command syntax, error handling and configuration of the status registers are explained in detail in the following sections. Tables provide a fast overview of the bit assignment in the status registers. The tables are supplemented by a comprehensive description of the status registers.

VISA

VISA is a standardized software interface library providing input and output functions to communicate with instruments. The I/O channel (LAN or USB) is selected at initialization time by means of a channel-specific resource string. For more information about VISA refer to its user documentation.

The programming examples for remote control are all written in Microsoft® VISUAL BASIC®. Access to the VISA functions require the declaration of the functions and constants prior to their use in the project. This can be accomplished either by adding the modules VISA32.BAS and VPPTYPE.BAS or a reference to the VISA32.DLL to the project.

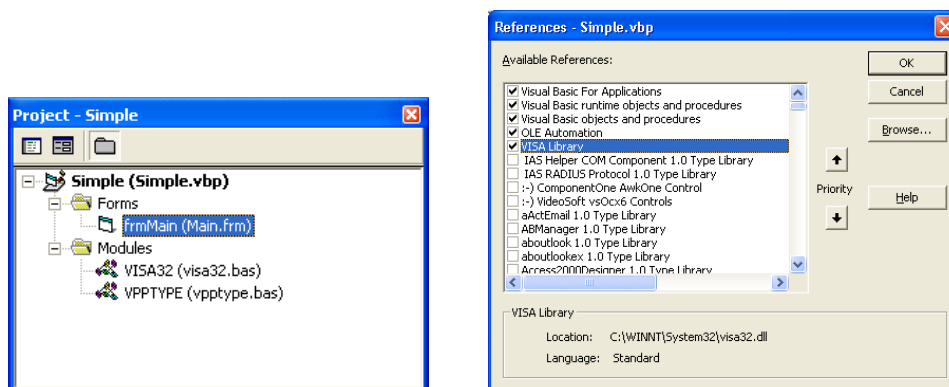

The modules visa32.bas and vpptype.bas can be found in the following location:

<VXIbnpPath>\WinNT\include (typically C:\VXIbnp\WinNT\include).



Resetting the R&S FSH

Manual operation is designed for maximum possible operating convenience. In contrast, the priority of remote control is the "predictability" of the device status. Therefore, control programs should always define an initial device status (e.g. with the command *RST) and then implement the required settings.

2.1 LAN Interface

To be integrated in a LAN, the instrument is equipped with a standard LAN interface, consisting of a connector, a network interface and protocols (VXI-11).

Instrument access via VXI-11 is usually achieved from high level programming platforms by using VISA as an intermediate abstraction layer. VISA encapsulates the low level VXI-11 (LAN) or USB function calls and thus makes the transport interface transparent for the user. The necessary VISA library is available as a separate product. For details contact your local R&S sales representative.

2.2 USB Interface

For remote control via the USB connection, the PC and the instrument must be connected via the USB interface. The required driver comes with the R&S InstrumentView software package and is automatically installed on the PC with the software package.

The driver addresses the instrument via the USB interface with the fix IP address 172.16.10.10.

In addition, a remote control connection via the SCPI interface requires the VISA library to be installed on the PC.

2.3 Protocols

VXI-11 Basics

The VXI-11 standard is based on the ONC-RPC protocol which in turn relies on TCP/IP as the network/transport layer. The TCP/IP network protocol and the associated network services are preconfigured. TCP/IP ensures connection-oriented communication, where the order of the exchanged messages is adhered to and interrupted links are identified. With this protocol, messages cannot be lost.

Remote control of an instrument via a network is based on standardized protocols which follow the OSI reference model (see Fig. below).

Application	SCPI
Presentation	XDR (VXI-11)
Session	ONC-RPC
Transport	TCP / UDP
Network	IP
Data Link	Ethernet/802.3
Physical	802.3/10BASE-T

Figure 2-1: Example for LAN remote control based on the OSI reference model

Based on TCP/UDP, messages between the controller and the instrument are exchanged via open network computing (ONC) - remote procedure calls (RPC). With XDR (VXI-11), legal RPC messages are known as VXI-11 standard. Based on this standard, messages are exchanged between the controller and the instrument. The messages are identical with SCPI commands. They can be organized in four groups:

- program messages (control command to the instrument)
- response messages (values returned by the instrument)
- service request (spontaneous queries of the instrument)
- low-level control messages (interface messages).

A VXI-11 link between a controller and an instrument uses three channels: core, abort and interrupt channel. Instrument control is mainly performed on the core channel (program, response and low-level control messages). The abort channel is used for immediate abort of the core channel; the interrupt channel transmits spontaneous service requests of the instrument. Link setup itself is very complex. For more details refer to the VXI-11 specification.

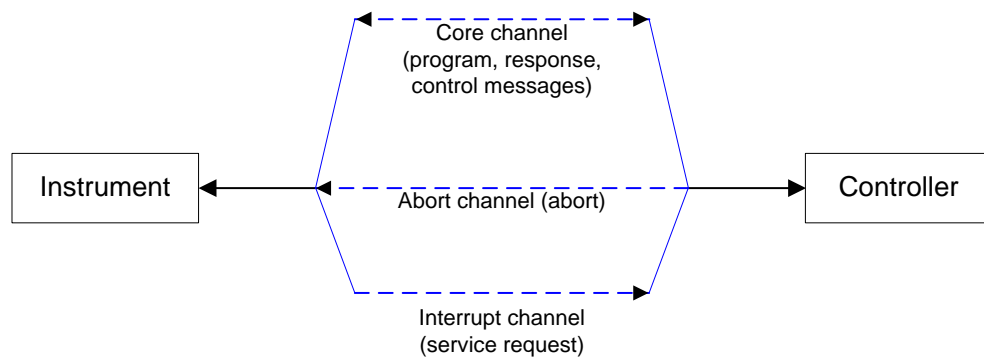

Figure 2-2: VXI-11 channels between instrument and controller

The number of controllers that can address an instrument is practically unlimited in the network. In the instrument, the individual controllers are clearly distinguished. This distinction continues up to the application level in the controller, i.e. two applications on a computer are identified by the instrument as two different controllers.

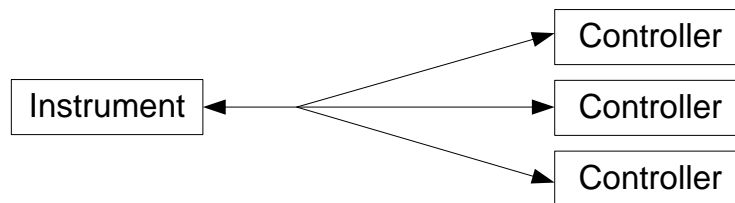

Figure 2-3: Remote control via LAN from several controllers

The controllers can lock and unlock the instrument for exclusive access. This regulates access to the instrument of several controllers.

3 Setting Up the Remote Control Connection

3.1 Preparing for Remote Control

The short and simple operating sequence below shows how to put the instrument into operation and quickly set its basic functions. The current IP address for LAN operation is shown in the SETUP – Instrument Setup Menu. In case of USB connection the IP address is fixed to 172.16.10.10.

Refer to the Quick Start Guide for instructions on how to change the IP address.

- ▶ Connect the instrument to the LAN or directly to the controller via USB.
- ▶ Switch on the instruments.
- ▶ Write and start the following program on the controller:

```
status = viOpenDefaultRM(defaultRM)
    'open default resource manager
status = viOpen(DefaultRM, "TCPIP::172.16.10.10", 0, 0, vi)
    'in case of USB connection
status = viOpen(DefaultRM, "TCPIP::xxx.xxx.xxx.xxx", 0, 0, vi)
    'in case of a LAN connection, with xxx.xxx.xxx.xxx = IP address
cmd = "*RST;*CLS"
status = viWrite(vi, Cmd, Len(Cmd), retCount)
    'reset instrument and clear status registers
cmd = "FREQ:CENT 100MHz"
status = viWrite(vi, Cmd, Len(Cmd), retCount)
    'set center frequency to 100 MHz
cmd = "FREQ:SPAN 10MHz"
status = viWrite(vi, Cmd, Len(Cmd), retCount)
    'set span to 10 MHz
cmd = "DISP:TRAC:Y:RLEV -10dBm"
status = viWrite(vi, Cmd, Len(Cmd), retCount)
    'set reference level to -10 dBm
viclose vi
viclose default RM
```

The instrument now performs a sweep in the frequency range of 95 MHz to 105 MHz.

Changing the IP Address

In order to operate the instrument via remote control, it must be accessed via LAN (IP address) or USB (fixed IP address). If the factory-set remote control address does not fit in the network environment, it can be changed. Refer to the Quick Start Guide, chapter "Setting up a LAN or USB Connection to a PC", for instructions on how to change the IP address.

4 Instrument Model and Command Processing

The block diagram in Fig. 1-2 shows how SCPI commands are serviced in the instrument. The individual components work independently and simultaneously. They communicate with each other by means of so-called "messages".

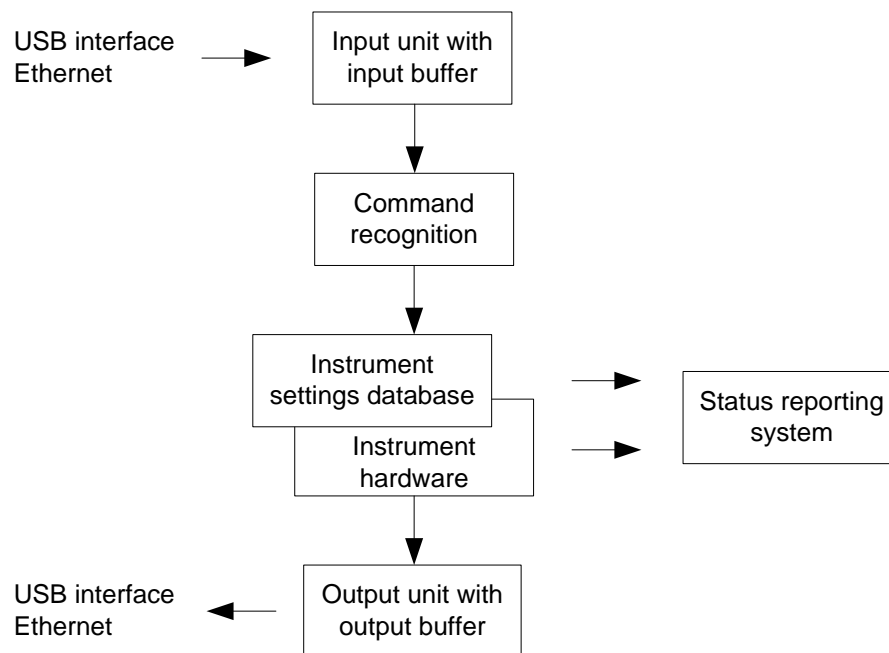

Figure 4-1: Instrument model in the case of remote control

4.1 Input Unit

The input unit receives commands character by character from the controller and collects them in the input buffer. The input unit sends a message to the command recognition as soon as the input buffer is full or as soon as it receives a delimiter, <PROGRAM MESSAGE TERMINATOR>, as defined in IEEE 488.2, or the interface message DCL.

If the input buffer is full, the traffic is stopped and the data received up to then are processed. Subsequently the traffic is continued. If, however, the buffer is not yet full when receiving the delimiter, the input unit can already receive the next command during command recognition and execution. The receipt of DCL clears the input buffer and immediately resets the command recognition.

4.2 Command Recognition

The command recognition analyses the data received from the input unit. It proceeds in the order in which it receives the data. Only DCL is serviced with priority, for example GET (Group Execute Trigger) is only executed after the commands received before. Each recognized command is immediately transferred to the internal instrument settings data base but not executed immediately.

The command recognition detects syntax errors in the commands and transfers them to the status reporting system. The rest of a program message after a syntax error is analyzed further if possible and serviced. After the syntax test, the value range of the parameter is checked, if required.

If the command recognition detects a delimiter, it passes the command to an execution unit that performs the instrument settings. In the meantime, the command recognition is ready to process new commands (overlapping execution). A DCL command is processed in the same way.

4.3 Data Base and Instrument Hardware

Here the expression "instrument hardware" denotes the part of the instrument fulfilling the actual instrument function - signal generation, measurement etc. The controller is not included. The term "data base" denotes a database that manages all the parameters and associated settings required for setting the instrument hardware.

Setting commands lead to an alteration in the data set. The data set management enters the new values (e.g. frequency) into the data set, however, only passes them on to the hardware when requested by the command recognition. This only takes place at the end of a program message.

The data are checked for compatibility with the current instrument settings before they are transmitted to the instrument hardware. If the execution is not possible, an "execution error" is signaled to the status reporting system. The corresponding settings are discarded.

Before passing on the data to the hardware, the settling bit in the STATus:OPERation register is set (refer to section "STATus:OPERation Register"). The hardware executes the settings and resets the bit again as soon as the new state has settled. This fact can be used to synchronize command servicing.

Queries induce the data set management to send the desired data to the output unit.

4.4 Status Reporting System

For detailed information refer to section "[Status Reporting System](#)".

4.5 Output Unit

The output unit collects the information requested by the controller, which it receives from the data base management. It processes it according to the SCPI rules and makes it available in the output buffer.

If the instrument is addressed as a talker without the output buffer containing data or awaiting data from the data base management, the output unit sends error message "Query UNTERMINATED" to the status reporting system. No data are sent to the controller, the controller waits until it has reached its time limit. This behavior is defined by IEEE 488.2 and SCPI.

5 SCPI Command Structure and Syntax

SCPI (Standard Commands for Programmable Instruments) describes a standard command set for programming instruments, irrespective of the type of instrument or manufacturer. The goal of the SCPI consortium is to standardize the device-specific commands to a large extent. For this purpose, a model was developed which defines the same functions inside a device or for different devices. Command systems were generated which are assigned to these functions. Thus it is possible to address the same functions with identical commands. The command systems are of a hierarchical structure.

SCPI is based on standard IEEE 488.2, i.e. it uses the same syntactic basic elements as well as the common commands defined in this standard. Part of the syntax of the device responses is defined with greater restrictions than in standard IEEE 488.2 (see section "Responses to Queries").



Remote command examples

Not all commands used in the following examples are implemented in the instrument.

5.1 Structure of a Command

The commands consist of a so-called header and, in most cases, one or more parameters. Header and parameter are separated by a "white space" (ASCII code 0 to 9, 11 to 32 decimal, e.g. blank). The headers may consist of several key words. Queries are formed by directly appending a question mark to the header.

5.1.1 Common Commands

Common commands consist of a header preceded by an asterisk "*" and one or several parameters, if any.

Examples

*RST	RESET, resets the device
*ESE 253	EVENT STATUS ENABLE, sets the bits of the event status enable register
*ESR?	EVENT STATUS QUERY, queries the contents of the event status register.

5.1.2 Device-Specific Commands

5.1.2.1 Hierarchy

Device-specific commands are of hierarchical structure. The different levels are represented by combined headers. Headers of the highest level (root level) have only one key word. This key word denotes a complete command system.

Example

```
SENSe
```

This key word denotes the SENSE command system.

For commands of lower levels, the complete path has to be specified, starting on the left with the highest level, the individual key words being separated by a colon ":".

Example

```
SENSe:FREQuency:SPAN 10MHZ
```

This command lies in the third level of the SENSE system. It sets the frequency span.

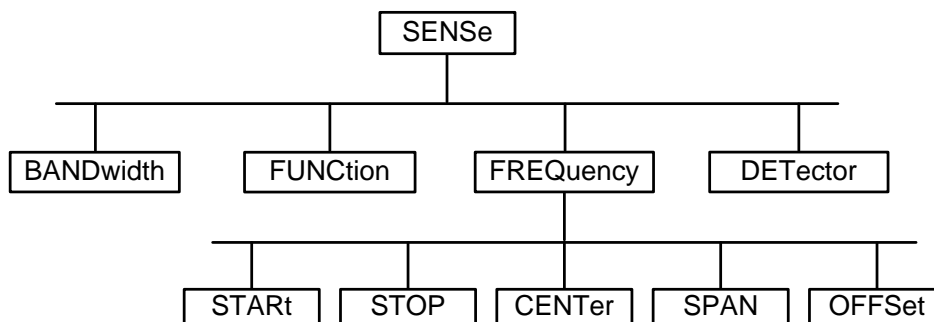

Figure 5-1: Tree structure the SCPI command systems using the SENSE system as example

5.1.2.2 Multiple Keywords

Some key words occur in several levels within one command system. Their effect depends on the structure of the command, i.e. at which position in the header of a command they are inserted.

Examples

```
SOURce:FM:POLarity NORMal
```

This command contains key word POLarity in the third command level. It defines the polarity between modulator and modulation signal.

```
SOURce:FM:EXTernal:POLarity NORMal
```

This command contains key word POLarity in the fourth command level. It defines the polarity between modulation voltage and the resulting direction of the modulation only for the external signal source indicated.

5.1.2.3 Optional Keywords

Some command systems permit certain key words to be inserted into the header or omitted. These key words are marked by square brackets in the description. The full command length must be recognized by the instrument for reasons of compatibility with the SCPI standard. Some commands are considerably shortened by these optional key words.

Example

```
[SENSe]:BANDwidth[:RESolution]:AUTO
```

This command couples the resolution bandwidth of the instrument to other parameters. The following command has the same effect:

```
BANDwidth:AUTO
```



Optional keywords with numeric suffixes

Do not omit an optional keyword if it includes a numeric suffix that is relevant for the effect of the command.

Example

```
DISPlay[:WINDow<1...4>]:MAXimize <Boolean>
```

Command `DISP:MAX ON` refers to window 1.

In order to refer to a window other than 1, you must include the optional `WINDow` parameter with the suffix for the required window.

`DISP:WIND2:MAX ON` refers to window 2.

5.1.2.4 Long and Short Form

The key words feature a long form and a short form. Either the short form or the long form can be entered, other abbreviations are not permitted.

Example

```
STATus:QUEStionable:ENABle 1
```

is equivalent to

```
STAT:QUES:ENAB 1
```



Upper and lower case notation of commands

Upper-case and lower-case notation only serves to distinguish the two forms in the manual, the instrument itself does not distinguish upper-case and lower-case letters.

5.1.2.5 Parameter

The parameter must be separated from the header by a "white space". If several parameters are specified in a command, they are separated by a comma ",". A few queries permit the parameters MINimum, MAXimum and DEFault to be entered. Refer to "[Parameters](#)" for a detailed description of the various parameters.

Example

```
SENSe:FREQuency:STOP? MAXimum
```

```
Response: 3.5E9
```

This query requests the maximal value for the stop frequency.

5.1.2.6 Special Characters

- | A vertical stroke in parameter definitions indicates alternative possibilities in the sense of "or". The effect of the command differs, depending on which parameter is used.

Example

```
DISPlay:FORMat SINGLE | SPLit
```

If parameter SINGLE is selected, full screen is displayed, in the case of SPLit, split screen is displayed.

A selection of key words with an identical effect exists for several commands. These keywords are indicated in the same line; they are separated by a vertical stroke. Only one of these keywords needs to be included in the header of the command. The effect of the command is independent of which of the keywords is used.

Example

```
SENSe:BANDwidth|BWIDth[:RESolution]
```

The two following commands with identical meaning can be created. They set the frequency of the fixed frequency signal to 1 kHz:

```
SENSe:BAND 1
```

```
SENSe:BWID 1
```

- [] Key words in square brackets can be omitted when composing the header. The full command length must be accepted by the instrument for reasons of compatibility with the SCPI standards.

Example

```
[SENSe:]BANDwidth|BWIDth[:RESolution]
```

```
SENS:BAND:RES
```

is equivalent to

```
BAND
```

Parameters in square brackets can be incorporated optionally in the command or omitted as well.

Example

```
MMEMemory:NETWork:MAP
<string>, <string>[, <string>, <string>, <boolean>]
```

Entries in square brackets are optional or can be omitted.

{ } Parameters in curly brackets are optional and can be inserted once or several times, or omitted.

Example

```
SENSE:LIST:FREQuency <numeric_value>{, <numeric_value>}
```

The following are valid commands:

```
SENS:LIST:FREQ 10
SENS:LIST:FREQ 10, 20
SENS:LIST:FREQ 10, 20, 30, 40
```

5.1.2.7 Numeric Suffix

If a device features several functions or features of the same kind, e.g. inputs, the desired function can be selected by a suffix added to the command. Entries without suffix are interpreted like entries with the suffix 1. Optional keywords must be specified if they select a function with the suffix.

Example

```
SYSTEM:COMMunicate:SERial2:BAUD 9600
```

This command sets the baud rate of a second serial interface.

**Suffix counting**

In case of remote control, suffix counting may differ from the numbers of the corresponding selection used in manual operation. SCPI prescribes that suffix counting starts with 1. Suffix 1 is the default state and used when no specific suffix is specified.

Some standards define a fixed numbering, starting with 0. With GSM, for instance, slots are counted from 0 to 7. In the case of remote control, the slots are selected with the suffixes 1 to 8. If the numbering differs in manual operation and remote control, it is indicated with the respective command.

5.1.3 Overview of Syntax Elements

The following table offers an overview of the syntax elements.

- : The colon separates the key words of a command. In a program message the separating semicolon marks the uppermost command level.
- ; The semicolon separates two commands within a program message. It does not alter the path.
- , The comma separates several parameters of a command.
- ? The question mark forms a query.
- * The asterisk marks a common command.
- " Quotation marks introduce a string and terminate it.
- # The hash symbol # introduces binary, octal, hexadecimal and block data.
 - Binary: #B10110
 - Octal: #O7612
 - Hexa: #HF3A7
 - Block: #21312

A "white space" (ASCII-Code 0 to 9, 11 to 32 decimal, e.g. blank) separates header and parameter.

5.2 Parameters

For most commands a parameter needs to be supplemented. The parameter has to be separated from the header by a "white space". Possible parameters are:

- Numeric values
- Special numeric values
- Boolean parameters
- Text
- Character strings
- Block data.

The type of parameter required for each command and the allowed range of values are specified in the command description.

5.2.1 Numeric Values

Numeric values can be entered in any form, i.e. with sign, decimal point and exponent. Values exceeding the resolution of the instrument are rounded up or down. The mantissa may comprise up to 255 characters, the exponent must lie inside the value range -32000 to 32000. The exponent is introduced by an "E" or "e". Entry of the exponent alone is not permissible. In the case of physical quantities, the unit can be entered. Permissible unit prefixes are G (giga), MA (mega), MOHM and MHZ are also possible), K (kilo), M (milli), U (micro) and N (nano). If the unit is missing, the basic unit is used.

Example

```
SENSe:FREQuency:STOP 1.5GHz = SENSe:FREQuency:STOP 1.5E9
```

5.2.2 Special Numeric Values

The texts MINimum, MAXimum, DEFault, UP and DOWN are interpreted as special numeric values. In case of a query, the numeric value is returned.

- MIN/MAX
MINimum and MAXimum denote the minimum and maximum value.
- DEF
DEFault denotes a preset value which has been stored in the EPROM. This value conforms to the default setting, as it is called by the *RST command
- UP/DOWN
UP, DOWN increases or reduces the numerical value by one step. The step width can be specified via an allocated step command for each parameter which can be set via UP, DOWN.

- INF/NINF

INFINITY, Negative INFINITY (NINF) Negative INFINITY (NINF) represent the numerical values -9.9E37 or 9.9E37, respectively. INF and NINF are only sent as device responses.

- NAN

Not A Number (NAN) represents the value 9.91E37. NAN is only sent as device response. This value is not defined. Possible causes are the division of zero by zero, the subtraction of infinite from infinite and the representation of missing values.

Example:

Setting command: `SENSe:FREQuency:STOP MAXimum`

Query: `SENSe:FREQuency:STOP?`, Response: `3.5E9`

5.2.3 Boolean Parameters

Boolean parameters represent two states. The ON state (logically true) is represented by ON or a numerical value unequal to 0. The OFF state (logically untrue) is represented by OFF or the numerical value 0. The numerical values are provided as response for query.

Example

Setting command: `CALCulate:MARKer:STATe ON`

Query: `CALCulate:MARKer:STATe?`, Response: `1`

5.2.4 Text

Text parameters observe the syntactic rules for key words, i.e. they can be entered using a short or long form. Like any parameter, they have to be separated from the header by a white space. In the case of a query, the short form of the text is provided.

Example

Setting command: `INPut:COUPling GROund`

Query: `INPut:COUPling?`, Response: `GRO`

5.2.5 Strings

Strings must always be entered in quotation marks (' or ").

Example

`SYSTem:LANGUage "SCPI"` or `SYSTem:LANGUage 'SCPI'`

5.2.6 Block Data

Block data are a transmission format which is suitable for the transmission of large amounts of data. A command using a block data parameter has the following structure:

Example

```
HEADer:HEADer #45168xxxxxxxx
```

ASCII character # introduces the data block. The next number indicates how many of the following digits describe the length of the data block. In the example the 4 following digits indicate the length to be 5168 bytes. The data bytes follow. During the transmission of these data bytes all end or other control signs are ignored until all bytes are transmitted.

5.3 Structure of a Program Message

A program message may consist of one or several commands. It is terminated by the program message terminator which is the NL (New Line) character for LAN and USB connections.

Several commands in a program message must be separated by a semicolon ";". If the next command belongs to a different command system, the semicolon is followed by a colon. A colon ":" at the beginning of a command marks the root node of the command tree.

Example:

```
CALL InstrWrite(analyzer, "SENSe:FREQuency:CENTer  
100MHz;:INPut:ATTenuation 10")
```

This program message contains two commands. The first one is part of the SENSe command system and is used to determine the center frequency of the instrument. The second one is part of the INPut command system and sets the input signal attenuation.

If the successive commands belong to the same system, having one or several levels in common, the program message can be abbreviated. For that purpose, the second command after the semicolon starts with the level that lies below the common levels (see also Fig. 1-1). The colon following the semicolon must be omitted in this case.

Example:

```
CALL InstrWrite(analyzer, "SENSe:FREQuency:START  
1E6;:SENSe:FREQuency:STOP 1E9")
```

This program message is represented in its full length and contains two commands separated from each other by the semicolon. Both commands are part of the SENSe command system, subsystem FREQuency, i.e. they have two common levels.

When abbreviating the program message, the second command begins with the level below SENSe:FREQuency. The colon after the semicolon is omitted. The abbreviated form of the program message reads as follows:

```
CALL InstrWrite(analyzer, "SENSe:FREQuency:START 1E6;STOP 1E9")
```

However, a new program message always begins with the complete path.

Example:

```
CALL InstrWrite(analyzer, "SENSe:FREQuency:START 1E6")  
CALL InstrWrite(analyzer, "SENSe:FREQuency:STOP 1E9")
```

5.4 Responses to Queries

A query is defined for each setting command unless explicitly specified otherwise. It is formed by adding a question mark to the associated setting command. According to SCPI, the responses to queries are partly subject to stricter rules than in standard IEEE 488.2.

- The requested parameter is transmitted without header.

Example

```
INPut:COUPling?
```

```
Response: DC
```

- Maximum values, minimum values and all further quantities, which are requested via a special text parameter are returned as numerical values.

Example

```
SENSe:FREQuency:STOP? MAX
```

```
Response: 3.5E9
```

- Numerical values are output without a unit. Physical quantities are referred to the basic units or to the units set using the Unit command.

Example

```
SENSe:FREQuency:CENTer?
```

```
Response: 1E6 (for 1 MHz)
```

- Truth values <Boolean values> are returned as 0 (for OFF) and 1 (for ON).

Example

```
SENSe:BANDwidth:AUTO?
```

```
Response: 1 (for ON)
```

- Text (character data) is returned in a short form.

Example

```
SYSTem:COMMunicate:SERial:CONTrol:RTS?
```

```
Response STAN (for standard)
```

6 Command Sequence and Command Synchronization

What has been said above makes clear that all commands can potentially be carried out overlapping. In order to prevent an overlapping execution of commands, one of the commands *OPC, *OPC? or *WAI must be used. All three commands cause a certain action only to be carried out after the hardware has been set. By suitable programming, the controller can be forced to wait for the respective action to occur. For more information see Table 6-1.

Table 6-1: Synchronization using *OPC, *OPC? and *WAI

Command	Action	Programming the controller
*OPC	Sets the Operation Complete bit in the ESR after all previous commands have been executed.	<ul style="list-style-type: none"> – Setting bit 0 in the ESE – Setting bit 5 in the SRE – Waiting for service request (SRQ)
*OPC?	Stops command processing until 1 is returned. This is only the case after the Operation Complete bit has been set in the ESR. This bit indicates that the previous setting has been completed.	Sending *OPC? directly after the command whose processing should be terminated before other commands can be executed.
*WAI	Stops further command processing until all commands sent before *WAI have been executed.	Sending *WAI directly after the command whose processing should be terminated before other commands are executed.

For a couple of commands the synchronization to the end of command execution is mandatory in order to obtain the desired result. The affected commands require either more than one measurement in order to accomplish the desired instrument setting (e.g. auto range functions), or they require a longer period of time for execution. If a new command is received during execution of the corresponding function this may either lead to either to an aborted measurement or to incorrect measurement data.

The following list includes the commands, for which a synchronization via *OPC, *OPC? or *WAI is mandatory:

Table 6-2: Commands with mandatory synchronization (overlapping commands)

Command	Purpose
INIT	start measurement (sweep)
INIT:CONT OFF	Set to single sweep
CALC:MARK:FUNC:xx?	All Marker function queries

7 Remote Control – Commands

The following chapters provide a detailed description of all remote control commands currently available for the R&S FSH and its firmware options.

Each section describes the commands for one of the operating modes available in the R&S FSH, beginning with the description of common commands required to operate the instrument. The structure is based on that of the operating manual.

- [Common Commands](#) on page 33
- [Remote Commands of the Spectrum Analyzer](#) on page 36
- [Remote Commands of the Network Analyzer Mode](#) on page 119
- [Remote Commands of the Distance-to-Fault Mode](#) on page 156
- [Remote Commands of the Receiver Mode](#) on page 171
- [Remote Commands of the Power Meter](#) on page 148
- [Remote Commands of the Digital Modulation Analyzer](#) on page 182

Each section is subdivided into various tasks required to perform measurements with the R&S FSH, also based on the structure of the operating manual. Some commands like those for controlling markers or configuring the frequency axis are available for all operating modes. In that case you will find a list of these commands in the corresponding section. However, a detailed description is provided only in the commands section of the main application.



Availability of commands

The spectrum and network analyzer modes are implemented in the basic unit. For the other modes, the corresponding options are required.

Following the remote control commands required to perform specific measurements, you will find a description of general commands used to set up and control basic instrument functions. These commands are independent of the operating mode. Therefore they are listed separately.

- [File Management](#) on page 279
- [Making and Storing Screenshots](#) on page 287
- [Configuring the Instrument](#) on page 294
- [Remote Commands of the Status Reporting System](#) on page 331

All chapters begin with a list of commands available in the context of that chapter. Following that list you will find a detailed description of all commands.

All individual descriptions contain:

- the complete notation and syntax of the command
- the description of the effects of the command
- a list of all parameters available for that command or the type of data the command returns in case of query commands
- an example of how a program message would look like
- the *RST value
- information on SCPI conformity

An alphabetical list of all available commands is provided at the end of this manual.

7.1 Common Commands

The common commands are taken from the IEEE 488.2 (IEC 625-2) standard. A particular command has the same effect on different devices. The headers of these commands consist of an asterisk "*" followed by three letters. Some of the common commands refer to the "Status Reporting System".

List of commands

- [*CLS](#) (p. 33)
- [*ESE](#) (p. 33)
- [*ESR?](#) (p. 33)
- [*IDN?](#) (p. 34)
- [*IST?](#) (p. 34)
- [*OPC](#) (p. 34)
- [*OPT?](#) (p. 34)
- [*RST](#) (p. 34)
- [*SRE](#) (p. 35)
- [*STB?](#) (p. 35)
- [*TRG](#) (p. 35)
- [*TST?](#) (p. 35)
- [*WAI](#) (p. 35)

*CLS

`CLEAR STATUS` sets the status byte (STB), the standard event register (ESR) and the EVENT part of the QUESTIONable and the OPERATION register to zero. The command does not alter the mask and transition parts of the registers. It clears the output buffer.

*ESE

`EVENT STATUS ENABLE` sets the event status enable register to the value indicated. The query form `*ESE?` returns the contents of the event status enable register in decimal form.

Parameter

0 to 255

*ESR?

`STANDARD EVENT STATUS QUERY` returns the contents of the event status register in decimal form (0 to 255) and subsequently sets the register to zero.

Parameter

0 to 255

***IDN?**

IDENTIFICATION QUERY queries the instrument identification.

You can change the format of the return values with the "SYSTem:FORMat:IDENT<IDNFormat>" command. **Return values**

<InstrumentName>,<SerialNumber/Model>,<FirmwareVersion>

Example for R&S FSH:

Rohde&Schwarz,FSH4,100005/024,1.50

***IST?**

INDIVIDUAL STATUS QUERY returns the contents of the IST flag in decimal form. The IST flag is the status bit which is sent during a parallel poll.

Parameter

0 | 1

***OPC**

OPERATION COMPLETE sets bit 0 in the event status register after all preceding commands have been executed. This bit can be used to initiate a service request.

***OPT?**

OPTION IDENTIFICATION QUERY queries the options included in the instrument and returns a list of the options installed. The options are separated from each other by means of commas.

Parameter

K<number> software options

For a list of all available options and their description refer to the CD-ROM.

Example

K40, K41, K42, K45

***RST**

RESET sets the instrument to a defined default status. The command essentially corresponds to pressing the PRESET key.

***SRE**

SERVICE REQUEST ENABLE sets the service request enable register to the indicated value. Bit 6 (MSS mask bit) remains 0. This command determines under which conditions a service request is generated. The query form *SRE? reads the contents of the service request enable register in decimal form. Bit 6 is always 0.

Parameter

0 to 255

***STB?**

READ STATUS BYTE QUERY reads out the contents of the status byte in decimal form.

***TRG**

TRIGGER initiates all actions in the currently active test screen expecting a trigger event. This command corresponds to `INITiate[:IMMediate]`.

***TST?**

SELF TEST QUERY initiates the self test of the instrument and outputs an error code in decimal form.

Parameter

0 = no error

***WAI**

WAIT TO CONTINUE permits servicing of subsequent commands only after all preceding commands have been executed and all signals have settled.

7.2 Remote Commands of the Spectrum Analyzer

This section provides a detailed description of all remote control commands required to configure and perform measurements with the spectrum analyzer. These commands are available in spectrum analyzer mode only.

Contents

[Configuring the Horizontal Axis](#) on page 37

[Configuring the Vertical Axis](#) on page 42

[Setting the Bandwidths](#) on page 49

[Performing and Triggering Measurements](#) on page 51

[Working with Traces](#) on page 60

[Using Markers](#) on page 66

[Using Display Lines and Limit Lines](#) on page 82

[Configuring and Using Measurement Functions](#) on page 88

7.2.1 Configuring the Horizontal Axis

The following commands configure the horizontal (frequency) axis of the active display.

The suffix <n> in the following commands selects the trace. Its range is {1..2}. Only relevant for segmented sweep.

List of commands

- [SENSe:]FREQUency:CENTer<n> <Frequency> (p. 37)
- [SENSe:]FREQUency:CENTer:STEP <StepSize> (p. 37)
- [SENSe:]FREQUency:CENTer:STEP:LINK <StepSizeCoupling> (p. 38)
- [SENSe:]FREQUency:INPut:MODE<n> <InputMode> (p. 38)
- [SENSe:]FREQUency:MODE <OperationMode> (p. 39)
- [SENSe:]FREQUency:OFFSet <FrequencyOffset> (p. 39)
- [SENSe:]FREQUency:SPAN<n> (p. 40)
- [SENSe:]FREQUency:SPAN<n>:AUTO <State> (p. 40)
- [SENSe:]FREQUency:SPAN<n>:FULL (p. 40)
- [SENSe:]FREQUency:STARt<n> <StartFrequency> (p. 41)
- [SENSe:]FREQUency:STOP<n> <StopFrequency> (p. 41)

[SENSe:]FREQUency:CENTer<n> <Frequency>

This command defines the center frequency of the R&S FSH.

In spectrum analyzer mode, the command also defines the measuring frequency for time domain measurements (span = 0).

Parameter

<Frequency>

Numeric value in Hz.

The range depends on the operating mode and is specified in the data sheet.

Example

```
FREQ:CENT 100MHz
```

Defines a center frequency of 100 MHz.

Characteristics

*RST value: $f_{\max} / 2$ with f_{\max} = maximum frequency

SCPI: conform

[SENSe:]FREQUency:CENTer:STEP <StepSize>

This command defines the center frequency step size.

Parameter

<StepSize>

Numeric value in Hz.

The range is from 1 Hz to f_{\max} .

Example

```
FREQ:CENT:STEP 120MHz
```

Defines a CF step size of 120 MHz.

Characteristics

*RST value: – (AUTO 0.1*SPAN is switched on)
 SCPI: conform

[SENSe:]FREQuency:CENTer:STEP:LINK <StepSizeCoupling>

This command couples and decouples the center frequency step size to the span.

For time domain measurements, the command couples the step size to the resolution bandwidth.

Parameter

<StepSizeCoupling>

DIVTen	Couples the step size to the span (10 %).
OFF	Turns the coupling off (manual step size).

Example

```
FREQ:CENT:STEP:LINK DIVT
```

Couples the step size to 10% of the span.

Characteristics

*RST value: DIVTen
 SCPI: device-specific

[SENSe:]FREQuency:INPut:MODE<n> <InputMode>

This command selects the frequency mode. Select the Channel frequency mode only if you want to work with channel tables. In this case, the input of the center frequency is not a frequency value, but a channel number.

Parameter

<InputMode>

FREQuency	Sets the frequency input mode to frequency input (in Hz).
CHANnel	Sets the frequency input mode to selection of a channel.

Example

```
FREQ:INP:MODE CHAN
```

Sets the frequency mode to work with channel tables.

Characteristics

*RST value: FREQ
 SCPI: device-specific

[SENSe:]FREQuency:MODE <OperationMode>

This command the measurement domain (frequency or time).

In the time domain (CW and FIXed), set the frequency with:

- [SENSe:]FREQuency:CENTer<n> <Frequency>

In the frequency domain (SWEep), set it with

- [SENSe:]FREQuency:CENTer<n> <Frequency>
- [SENSe:]FREQuency:SPAN<n>
- [SENSe:]FREQuency:STARt<n> <StartFrequency>
- [SENSe:]FREQuency:STOP<n> <StopFrequency>

Parameter

<OperationMode>

CW	Selects the time domain (span = 0)
FIXed	Selects the time domain (span = 0)
SWEep	Selects the frequency domain (span > 0).

Example

```
FREQ:MODE SWE
```

Activates frequency domain measurements.

Characteristics

*RST value: SWEep

SCPI: conform

[SENSe:]FREQuency:OFFSet <FrequencyOffset>

This command defines a frequency offset.

Parameter

<FrequencyOffset>

Numeric value in the range from -100 GHz to 100 GHz.

Example

```
FREQ:OFFS 1GHZ
```

Defines a frequency offset of 1 GHz.

Characteristics

*RST value: 0 Hz

SCPI: conform

**[SENSe:]FREQuency:SPAN<n> **

This command defines the frequency span.

If you set a span of 0 Hz in spectrum mode, the R&S FSH starts a measurement in the time domain.

Parameter

Numeric value in Hz. The value range is specified in the data sheet.

Example

```
FREQ:SPAN 10MHz  
Defines a span of 10 MHz.
```

Characteristics

*RST value: f_{\max} with f_{\max} = maximum frequency
SCPI: conform

[SENSe:]FREQuency:SPAN<n>:AUTO <State>

This command turns the automatic calculation of the ideal span on and off.

Parameter

<State>

ON | OFF

Example

```
FREQ:SPAN:AUTO ON  
Turns automatic span determination on and off.
```

Characteristics

*RST value: OFF
SCPI: device-specific

[SENSe:]FREQuency:SPAN<n>:FULL

This command restores the full span.

This command is an event and therefore has no query and no *RST value.

Example

```
FREQ:SPAN:FULL  
Restores full span.
```

Characteristics

*RST value: –
SCPI: conform

[SENSe:]FREQuency:STARt<n> <StartFrequency>

This command defines the start frequency for measurements in the frequency domain (span > 0).

Parameter

<StartFrequency>
Numeric value in Hz.

The range depends on the operating mode and is specified in the datasheet.

Example

```
FREQ:STAR 20MHz
```

Defines a start frequency of 20 MHz.

Characteristics

*RST value: 0
SCPI: conform

[SENSe:]FREQuency:STOP<n> <StopFrequency>

This command defines the stop frequency for measurements in the frequency domain (span > 0).

Parameter

<StopFrequency>
Numeric value in Hz.

The range depends on the operating mode and is specified in the datasheet.

Example

```
FREQ:STOP 2000MHz
```

Defines a stop frequency of 2 GHz

Characteristics

*RST value: f_{\max}
SCPI: conform

7.2.2 Configuring the Vertical Axis

The following commands configure the vertical (level) axis and level parameters of the active display.

The suffix <c> at TRANsducer selects the primary or secondary transducer. The range is <1...2>.

The suffix <n> in the following commands selects the trace. Its range is {1..2}. Only relevant for segmented sweep.

List of commands

- [DISPlay\[:WINDow\]:TRACe<n>:Y\[:SCALe\]:ADJust](#) (p. 42)
- [DISPlay\[:WINDow\]:TRACe<n>:Y:SPACing <Scaling>](#) (p. 42)
- [DISPlay\[:WINDow\]:TRACe<n>:Y\[:SCALe\] <DisplayRange>](#) (p. 43)
- [DISPlay\[:WINDow\]:TRACe<n>:Y\[:SCALe\]:RLEVel <ReferenceLevel>](#) (p. 43)
- [DISPlay\[:WINDow\]:TRACe<n>:Y\[:SCALe\]:RLEVel:OFFSet <Offset>](#) (p. 44)
- [DISPlay\[:WINDow\]:TRACe:Y\[:SCALe\]:RPOSition <ReferencePosition>](#) (p. 44)
- [INPut<n>:ATTenuation <Attenuation>](#) (p. 44)
- [INPut<n>:ATTenuation:MODE <AttenuationMode>](#) (p. 45)
- [INPut<n>:ATTenuation:AUTO <State>](#) (p. 45)
- [INPut<n>:GAIN:STATe <State>](#) (p. 46)
- [INPut:IMPedance <Impedance>](#) (p. 46)
- [\[SENSe:\]CORRection:TRANsducer<c>\[:STATe\] <State>](#) (p. 46)
- [\[SENSe:\]CORRection:TRANsducer<c>:SElect <TransducerFactor>](#) (p. 47)
- [\[SENSe:\]CORRection:TRANsducer<c>:UNIT?](#) (p. 47)
- [UNIT<n>:POWER <Unit>](#) (p. 48)

DISPlay[:WINDow]:TRACe<n>:Y[:SCALe]:ADJust

This command automatically scales the vertical axis for optimum display results.

This command is an event and therefore has no query and no *RST value.

Example

```
DISP:TRAC:Y:ADJ
Adjusts the y-axis.
```

Characteristics

*RST value: -
SCPI: device-specific

DISPlay[:WINDow]:TRACe<n>:Y:SPACing <Scaling>

This command selects the scaling of the vertical axis.

Parameter

<Scaling>

LOGarithmic	Selects a logarithmic scale.
LINear	Selects a linear scale (%).

Example

```
DISP:TRAC:Y:SPAC LIN
```

Selects linear scaling of the level axis.

Characteristics

*RST value: LOGarithmic
SCPI: conform

DISPlay[:WINDow]:TRACe<n>:Y[:SCALE] <DisplayRange>

This command defines the display range of the vertical axis.

Note that you have to set a logarithmic scaling before you can use this command with `DISPlay[:WINDow]:TRACe<n>:Y:SPACing`. For a linear scale, you can not modify the display range as it is fixed.

Parameter

<DisplayRange>
numeric value in the range from 10 dB to 200 dB

Example

```
DISP:TRAC:Y 110dB
```

Sets the display range to 110 dB.

Characteristics

*RST value: 100dB
SCPI: device-specific

DISPlay[:WINDow]:TRACe<n>:Y[:SCALE]:RLEVEL <ReferenceLevel>

This command defines the reference level.

With a reference level offset $\neq 0$, the value range of the reference level is modified by the offset.

Parameter

<ReferenceLevel>
numeric value that sets the reference level; the unit depends on `UNIT<n>:POWER`.

The available value range is specified in the data sheet.

Example

```
DISP:TRAC:Y:RLEV -60dBm
```

Sets the reference level to -60 dBm.

Characteristics

*RST value: -20dBm
SCPI: conform

DISPlay[:WINDow]:TRACe<n>:Y[:SCALe]:RLEVel:OFFSet <Offset>

This command defines a reference level offset.

Parameter

<Offset>

numeric value (dB) that sets the reference level offset

The available value range is from -200dB to 200dB.

Example

```
DISP:TRAC:Y:RLEV:OFFS -10dB
```

Characteristics

*RST value: 0dB

SCPI: conform

DISPlay[:WINDow]:TRACe:Y[:SCALe]:RPOSition <ReferencePosition>

This command defines the position of the reference level on the display grid.

First, you have to set a logarithmic scale for the vertical axis with [DISPlay\[:WINDow\]:TRACe<n>:Y:SPACing](#). For a linear scale, you can not modify the reference position.

Parameter

<ReferencePosition>

numeric value (%) that defines the reference position

The available value range is from 1 to 10.

Example

```
DISP:TRAC:Y:RPOS 5
```

Sets the reference position to the 5th grid line.

Characteristics

*RST value:10

SCPI: conform

INPut<n>:ATTenuation <Attenuation>

This command defines the input attenuation.

In spectrum mode, the attenuation is coupled to the reference level. If you set the attenuation independently, the R&S FSH turns off this coupling.

The R&S FSH adjusts the reference level if it can not be set for the current RF attenuation.

Parameter

<Attenuation>

Numeric value in in the range from 0 dB to 40 dB in 5 dB steps.

Example

```
INP:ATT 30dB
```

Defines an attenuation of 30 dB and deactivates coupling to the reference level.

Characteristics

*RST value: 0 dB (AUTO is ON)

SCPI: conform

INPut<n>:ATTenuation:MODE <AttenuationMode>

This command selects the attenuation mode.

Parameter

<AttenuationMode>

LDIstortion	Selects "Auto Low Distortion" mode.
LNOise	Selects "Auto Low Noise" mode.

Example

```
INP:ATT:MODE LNO
```

Sets the attenuation mode to Auto Low Noise.

Characteristics

*RST value: LNOise

SCPI: device-specific

INPut<n>:ATTenuation:AUTO <State>

This command couples and decouples input attenuation to the reference level.

Parameter

<State>

ON | OFF

Example

```
INP:ATT:AUTO ON
```

Couples the attenuation set on the attenuator to the reference level.

Characteristics

*RST value: ON

SCPI: conform

INPut<n>:GAIN:STATe <State>

This command turns the preamplifier on and off.

Parameter

<State>
ON | OFF

Example

```
INP:GAIN:STAT ON
Activates the preamplifier
```

Characteristics

*RST value: OFF
SCPI: conform

INPut:IMPedance <Impedance>

This command selects the nominal input impedance. The set impedance is taken into account in all level indications of results.

The setting 75 Ω should be selected, if the 50 Ω input impedance is transformed to a higher impedance using a 75 Ω adapter of the RAZ type (= 25 Ω in series to the input impedance of the instrument). The correction value in this case is 1.76 dB = 10 log (75Ω / 50Ω).

Parameter

<Impedance>
50 | 75

Example

```
INP:IMP 75
Sets the input impedance to 75 Ohm.
```

Characteristics

*RST value: 50 Ω
SCPI: conform

[SENSe:]CORRection:TRANsducer<c>[:STATe] <State>

This command turns a transducer factor on and off.

Before turning it on, you have to select a transducer factor with [\[SENSe:\]CORRection:TRANsducer<c>:SElect](#).

Parameter

<State>
ON | OFF

Example

```
CORR:TRAN1 ON
```

Activates the primary transducer

Characteristics

*RST value: OFF
SCPI: device-specific

[SENSe:]CORRection:TRANsducer<c>:SElect <TransducerFactor>

This command selects a transducer factor.

If <name> does not exist yet, a new transducer factor is created.

The suffix<1...2> specifies the primary or secondary transducer.

Parameter

<Transducerfactor>
string containing the file name of the transducer factor.

If the file does not exist, the R&S FSH creates a new transducer factor.

Example

```
CORR:TRAN2:SEL 'FSH-Z38.sectrd'
```

Selects the FSH-Z38 secondary transducer factor.

Characteristics

*RST value: -
SCPI: device-specific

[SENSe:]CORRection:TRANsducer<c>:UNIT?

This command queries the unit of the current transducer factor.

Example

```
CORR:TRAN2:UNIT?
```

Queries the unit of the primary transducer.

Characteristics

*RST value: -
SCPI: device-specific

UNIT<n>:POWER <Unit>

This command selects the unit of the vertical axis.

The availability of units depends on the operating mode and type of measurement.

Parameter

<Unit>

DBM | DBUV | DBMV | V | W | DUVM | DUAM | V_M | W_M2

Note that the availability of units depends on the operating mode.

Example

```
UNIT:POW DBUV
```

Sets the power unit to dB μ V.

Characteristics

*RST value: DBM

SCPI: conform

7.2.3 Setting the Bandwidths

The following commands configure the filter bandwidths of the R&S FSH. Note that both groups of commands (BANDwidth and BWIDth) are the same.

The suffix <n> in the following commands selects the trace. Its range is {1..2}. Only relevant for segmented sweep.

List of commands

- [SENSe:]BANDwidth|BWIDth<n>[:RESolution] <ResBW> (p. 49)
- [SENSe:]BANDwidth|BWIDth<n>[:RESolution]:AUTO <State> (p. 49)
- [SENSe:]BANDwidth|BWIDth<n>:VIDeo <VideoBW> (p. 50)
- [SENSe:]BANDwidth|BWIDth<n>:VIDeo:AUTO <State> (p. 50)

[SENSe:]BANDwidth|BWIDth<n>[:RESolution] <ResBW>

This command defines the resolution bandwidth.

Parameter

<ResBW>

Numeric value in Hz.

The available value range is from 1 Hz to 3 MHz in 1 - 3 - 10 steps. In addition, you can select a 200 kHz and 5 MHz bandwidth.

In zero span, the R&S FSH also provides a 10 MHz and 20 MHz bandwidth.

Example

```
BAND 100 kHz
```

Sets the resolution bandwidth to 100 kHz

Characteristics

*RST value: - (AUTO is set to ON)

SCPI: conform

[SENSe:]BANDwidth|BWIDth<n>[:RESolution]:AUTO <State>

This command couples and decouples the resolution bandwidth to the span.

Parameter

<State>

ON | OFF

Example

```
BAND:AUTO OFF
```

Decouples the resolution bandwidth from the span.

Characteristics

*RST value: ON

SCPI: conform

[SENSe:]BANDwidth|BWIDth<n>:VIDeo <VideoBW>

This command defines the video bandwidth.

Parameter

<VideoBW>

Numeric value in Hz.

The available value range is from 1 Hz to 3 MHz in 1 - 3 steps.

Example

```
BAND:VID 10kHz
```

Sets the video bandwidth to 10 kHz.

Characteristics

*RST value: - (AUTO is set to ON)

SCPI: conform

[SENSe:]BANDwidth|BWIDth<n>:VIDeo:AUTO <State>

This command couples and decouples the video bandwidth to the resolution bandwidth.

Parameter

<State>

ON | OFF

Example

```
BAND:VID:AUTO OFF
```

Turns off video bandwidth coupling.

Characteristics

*RST value: ON

SCPI: conform

7.2.4 Performing and Triggering Measurements

The following commands control the actual measurement process, including trigger functionality.

7.2.4.1 Performing the Measurement

The following commands initialize a measurement and set up the sweep.

The suffix <n> in the following commands selects the trace. Its range is {1..2}. Only relevant for segmented sweep.

List of commands

- [*WAI](#) (p. 35)
- [ABORt](#) (p. 51)
- [INITiate\[:IMMEDIATE\]](#) (p. 51)
- [INITiate:CONTinuous <SweepMode>](#) (p. 52)
- [\[SENSe:\]SWEEp:COUNT<n> <SweepCount>](#) (p. 52)
- [\[SENSe:\]SWEEp:POINTs?](#) (p. 53)
- [\[SENSe:\]SWEEp:TIME<n> <SweepTime>](#) (p. 53)
- [\[SENSe:\]SWEEp:TIME<n>:AUTO <State>](#) (p. 53)

ABORt

This command aborts the current measurement and resets the trigger system.

This command is an event and therefore has no query and no *RST value.

Example

```
ABOR;
INIT: IMM
```

Aborts a measurement and starts a new one.

Characteristics

RST value: –
SCPI: conform

INITiate[:IMMEDIATE]

The command initiates a new measurement sequence.

With sweep count > 0 or average count > 0, this means a restart of the indicated number of measurements. With trace functions MAXHold, MINHold and AVERage, the previous results are reset on restarting the measurement.

In single sweep mode, synchronization to the end of the indicated number of measurements can be achieved with the command *OPC, *OPC? or *WAI. In continuous-sweep mode, synchronization to the sweep end is not possible since the overall measurement never ends.

This command is an event and therefore has no query and no *RST value.

Example

```
INIT:CONT OFF
DISP:WIND:TRAC:MODE AVER
Turns single sweep mode and trace averaging on.
```

```
INIT;*WAI
Starts the measurement and waits for the end of the sweep.
```

Characteristics

*RST value: –
SCPI: conform

INITiate:CONTinuous <SweepMode>

This command selects the sweep mode.

Parameter

<SweepMode>

ON	Selects continuous sweeps.
OFF	Selects single sweep.

Example

```
INIT:CONT OFF
Turns on single sweep mode.
```

Characteristics

*RST value: ON
SCPI: conform

[SENSe:]SWEep:COUNT<n> <SweepCount>

This command defines the number of sweeps included in a single sweep. It also defines the number of sweeps the R&S FSH uses to average traces or calculate maximum values.

The R&S FSH performs one sweep for sweep count 0 or 1.

Parameter

<SweepCount>
0 to 999

Example

```
SWE:COUN 64
Defines a sweep count of 64 sweeps.
```

```
INIT:CONT OFF
INIT;*WAI
Turns on single sweep mode, starts the sweep and waits for its end.
```

Characteristics

*RST value: 1
 SCPI: conform

[SENSe:]SWEep:POINts?

This command queries the number of measurement points in a single sweep.

This command is a query and therefore has no *RST value.

Return value

Number of sweep points.

Example

SWE:POIN?
 Returns the number of sweep points.

Characteristics

*RST value: –
 SCPI: conform

[SENSe:]SWEep:TIME<n> <SweepTime>

This command defines the sweep time.

If you set a sweep time in spectrum mode with this command, the R&S FSH decouples the sweep time from the span and the resolution and video bandwidths.

Parameter

<SweepTime>
 Numeric value in seconds.

The available value range is specified in the datasheet.

Example

SWE:TIME 10s
 Sets the sweep time to 10 s

Characteristics

*RST value: - (AUTO is set to ON)
 SCPI: conform

[SENSe:]SWEep:TIME<n>:AUTO <State>

This command couples and decouples the sweep time to the span and the resolution and video bandwidths.

Parameter

<State>
 ON | OFF

Example

```
SWE:TIME:AUTO ON
```

Switches on the coupling to frequency span and bandwidths.

Characteristics

*RST value: ON

SCPI: conform

7.2.4.2 Capturing I/Q Data

The following commands control I/Q data capture.

List of commands

- [TRACe:IQ:DATA:MEMory? \[<OffsetSamples>,<Samples>\]](#) (p. 54)
- [TRACe:IQ:RLENgth <Samples>](#) (p. 55)
- [TRACe:IQ:SRATe <SampleRate>](#) (p. 55)
- [TRACe:IQ\[:STATe\] <State>](#) (p. 55)

TRACe:IQ:DATA:MEMory? [<OffsetSamples>,<Samples>]

This command queries the I/Q data in the capture buffer.

By default, it returns all samples in the capture buffer. You can, however, narrow down the amount of data that the command returns using the optional parameters.

This command is a query and therefore has no *RST value.

Parameter

<OffsetSamples>

Defines the first sample to return in relation to the first sample in the capture buffer.

<Samples>

Defines the number of samples to return.

Return value

<IQData>

Measured value pair (I,Q) for each sample that has been recorded. The order is I,I,I,I,(...),Q,Q,Q,Q,(...)

Example

```
TRAC:IQ ON
```

Turn on I/Q data capture.

```
TRAC:IQ:RLEN 10000
```

```
TRAC:IQ:SRAT 1000000
```

Capture 10000 samples with 1 MHz sample rate.

```
INIT:CONT OFF
```

```
INIT;*WAI
```

Selects single sweep and initiate measurement.

```
TRAC:IQ:DATA:MEM? 1000,5000
```

Queries 5000 samples, beginning with the 1000th sample.

Characteristics

*RST value: -

SCPI: device-specific

TRACe:IQ:RLENgth <Samples>

This command defines the number of samples to capture.

Parameter

<Samples>

Number of samples in the range from 1 to 524288.

Example

```
TRAC:IQ:RLEN 10000
```

Capture 10000 samples.

*RST value: 1000

SCPI: device-specific

TRACe:IQ:SRATe <SampleRate>

This command defines the sample rate.

The maximum sample rate depends on the instrument variant you have. It is either 38.4 MHz or 15 MHz.

Parameter

<SampleRate>

Sample rate in Hz.

Example

```
TRAC:IQ:SRAT 1000000
```

Define a 1 MHz sample rate.

```
TRAC:IQ:SRAT MAX
```

```
TRAC:IQ:SRAT?
```

Query maximum sample rate

*RST value: 10 MHz

SCPI: device-specific

TRACe:IQ[:STATe] <State>

This command turns I/Q capture mode on and off.

Parameter

<State>

ON | OFF.

Example

```
TRAC:IQ ON
Turn on I/Q capture mode.
```

```
*RST value: OFF
SCPI: device-specific
```

7.2.4.3 Triggering Measurements

The following commands set up trigger conditions if you are using a trigger for the measurement.

The suffix <n> in the following commands selects the trace. Its range is {1..2}. Only relevant for segmented sweep.

List of commands

- [\[SENSe:\]SWEep:EGATe <State> \(p. 56\)](#)
- [\[SENSe:\]SWEep:EGATe:HOLDoff <GateDelay> \(p. 56\)](#)
- [\[SENSe:\]SWEep:EGATe:LENGth <GateLength> \(p. 57\)](#)
- [\[SENSe:\]SWEep:EGATe:TIME <SweepTime> \(p. 57\)](#)
- [TRIGger\[:SEQuence\]:CLOCK\[:FREQuency\] <ClockRate> \(p. 57\)](#)
- [TRIGger<n>\[:SEQuence\]:HOLDoff\[:TIME\] <TriggerDelay> \(p. 58\)](#)
- [TRIGger<n>\[:SEQuence\]:LEVel:VIDeo <TriggerLevel> \(p. 58\)](#)
- [TRIGger<n>\[:SEQuence\]:SLOPe <TriggerSlope> \(p. 58\)](#)
- [TRIGger<n>\[:SEQuence\]:SOURce <TriggerSource> \(p. 59\)](#)

[SENSe:]SWEep:EGATe <State>

This command turns a gated trigger on and off.

Parameter

```
<State>
ON | OFF
```

Example

```
SWE:EGAT ON
Activates the gated trigger.
```

Characteristics

```
*RST value: off
SCPI: device-specific
```

[SENSe:]SWEep:EGATe:HOLDoff <GateDelay>

This command defines the length of the gate delay.

Parameter

```
<GateDelay>
Numeric value in the range from 0 s to 100 s.
```

Example

SWE:EGAT:HOLD 2.5
Sets a gate delay of 2.5 seconds.

Characteristics

*RST value: 0 s
SCPI: device-specific

[SENSe:]SWEep:EGATe:LENGth <GateLength>

This command defines the gate length.

Parameter

<GateLength>
Numeric value in the range from 10 μ s to 100 s.

Example

SWE:EGAT:LENG 2.5
Sets a gate length of 2.5 seconds.

Characteristics

*RST value: 400 μ s
SCPI: device-specific

[SENSe:]SWEep:EGATe:TIME <SweepTime>

This command defines the sweep time for the gated trigger.

Parameter

<SweepTime>
Numeric value in seconds.

Example

SWE:GATE:TIME 4ms
Sets a sweep time of 4 ms for the gated trigger.

Characteristics

*RST value: 400 μ s
SCPI: device-specific

TRIGger[:SEquence]:CLOCK[:FREQUENCY] <ClockRate>

This command defines the clock rate of the internal trigger.

Parameter

<ClockRate>
Clock rate that defines the trigger intervals in Hz.

Example

```
TRIG:CLOC 100
```

Triggers a measurement every 100 ms.

Characteristics

*RST value: 100 Hz
 SCPI: device-specific

TRIGger<n>[:SEQUENCE]:HOLDoff[:TIME] <TriggerDelay>

This command defines the length of the trigger delay.

Parameter

<TriggerDelay>
 Numeric value in the range from 0 s to 100 s.

Example

```
TRIG:HOLD 500us
```

Sets the trigger delay to 500 µs.

Characteristics

*RST value: 0 s
 SCPI: conform

TRIGger<n>[:SEQUENCE]:LEVEL:VIDeo <TriggerLevel>

This command defines the level of the video trigger.

Video trigger is available for time domain measurements (span = 0).

Parameter

<TriggerLevel>
 Numeric value in the range from 0 % to 100 %.

Example

```
TRIG:LEV:VID 50PCT
```

Sets the trigger level to 50%.

Characteristics

*RST value: 50 PCT
 SCPI: device-specific

TRIGger<n>[:SEQUENCE]:SLOPe <TriggerSlope>

This command selects the slope of the trigger signal.

The trigger slope applies to all trigger sources.

Parameter

<TriggerSlope>
 POSitive | NEGative

Example

```
TRIG:SLOP NEG
```

Characteristics

*RST value: POSitive

SCPI: conform

TRIGger<n>[:SEQuence]:SOURce <TriggerSource>

This command selects the trigger source.

Parameter

<TriggerSource>

IMMediate	Selects Free Run measurements.
EXTernal	Selects an external trigger.
INTernal	Internal trigger.
VIDeo	Selects the video trigger.

For more information see R&S FSH operating manual chapter "Setting the Sweep"

Example

```
TRIG:SOUR EXT
```

Selects the external trigger input as source of the trigger signal

Characteristics

*RST value: IMMediate

SCPI: conform

7.2.5 Working with Traces

The following commands set up the trace and the various functions associated with it, e.g. trace mathematics or the selection of the detector.

The suffix <n> in the following commands selects the trace. Its range is {1..2}. Only relevant for segmented sweep.

List of commands

- [CALCulate:MATH<n>\[:EXPRession\]\[:DEFine\] <Expression>](#) (p. 60)
- [CALCulate:MATH<n>:COPY:MEMory](#) (p. 60)
- [CALCulate:MATH<n>:STATe <State>](#) (p. 61)
- [DISPlay\[:WINDow\]:TRACe<n>\[:STATe\] <State>](#) (p. 61)
- [DISPlay\[:WINDow\]:TRACe<n>:MEMory\[:STATe\] <State>](#) (p. 61)
- [DISPlay\[:WINDow\]:TRACe<n>:MODE <TraceMode>](#) (p. 62)
- [FORMat:BORDER <ByteOrder>](#) (p. 62)
- [\[SENSe:\]DETEctor<n>\[:FUNCTion\] <Detector>](#) (p. 63)
- [\[SENSe:\]DETEctor<n>\[:FUNCTion\]:AUTO <State>](#) (p. 63)
- [TRACe<n>\[:DATA\]? <Destination>](#) (p. 63)
- [TRACe<n>:DATA:MEMory? <Trace>](#) (p. 64)
- [FORMat\[:DATA\] <DataFormat>](#) (p. 65)

CALCulate:MATH<n>[:EXPRession][:DEFine] <Expression>

This command defines the mathematical expression for relating traces to trace 1.

You have to activate trace mathematics with [CALCulate:MATH<n>:STATe <State>](#) first.

Parameter

<Expression>

(IMPLied - memory)	Subtracts the trace in memory from the current trace.
--------------------	---

(memory - IMPLied)	Subtracts the current trace from the trace in memory.
--------------------	---

Example

```
CALC:MATH (MTRACE-TRACE)
```

Selects the subtraction of the current trace from trace in the memory.

Characteristics

*RST value: –

SCPI: conform

CALCulate:MATH<n>:COPY:MEMory

This command stores the selected trace into the memory trace of the R&S FSH.

This command is an event and therefore has no query and no *RST value.

Example

```
CALC:MATH:COPY:MEM
```

Copies the trace into the memory.

Characteristics

*RST value: -

SCPI: device-specific

CALCulate:MATH<n>:STATe <State>

This command turns trace mathematics on and off.

Parameter

<State>

ON | OFF

Example

```
CALC:MATH:STAT ON
```

Switches on the trace mathematics.

Characteristics

*RST value: OFF

SCPI: conform

DISPlay[:WINDow]:TRACe<n>[:STATe] <State>

This command turns a trace on and off.

Parameter

<State>

ON | OFF

Example

```
DISP:TRAC2 ON
```

Turns the trace on.

Characteristics

*RST value: ON for TRACe1, OFF for TRACe2

SCPI: conform

DISPlay[:WINDow]:TRACe<n>:MEMory[:STATe] <State>

This command turns the memory trace on and off.

Parameter

<State>

ON | OFF

Example

```
DISP:TRAC:MEM ON
```

Activates the memory trace.

Characteristics

*RST value: OFF
 SCPI: device-specific

DISPlay[:WINDow]:TRACe<n>:MODE <TraceMode>

This command selects the trace mode.

If you are using the average, max hold or min hold trace mode, you can set the number of measurements with [SENSe:]SWEep:COUNT<n> <SweepCount>. Note that synchronization to the end of the average count is possible only in single sweep mode.

Parameter

<TraceMode>
 AVERage | MAXHold | MINHold | VIEW | WRITe

You can turn off the trace with `DISPlay[:WINDow]:TRACe<n>[:STATe] <State>`.

For more information see the operating manual, chapter "Trace Mode".

Example

```
INIT:CONT OFF
```

```
SWE:COUN 16
```

Turn on single sweep mode and sets the number of measurements to 16.

```
DISP:TRAC:MODE MAXH
```

Activates MAXHold mode for the trace.

```
INIT;*WAI
```

Starts the measurement and waits for the end of the 16 sweeps.

Characteristics

*RST value: WRITe
 SCPI: device-specific

FORMat:BORDER <ByteOrder>

This command selects the format of binary data.

Parameters

<ByteOrder>

SWAPped	The least significant byte is transferred first (little endian).
NORMal	The most significant byte is transferred first big endian).

Example

```
FORM:BORD NORM
```

Changes the byte order to normal mode

Characteristics

*RST value SWAPped

SCPI: conform

[SENSe:]DETEctor<n>[:FUNction] <Detector>

This command selects the detector.

Parameter

<Detector>

APEak | NEGative | POSitive | SAMPlE | RMS

For more information see the operating manual, chapter "Detectors".

Example

```
DET POS
```

Sets the detector to "positive peak".

Characteristics

*RST value: POS

SCPI: conform

[SENSe:]DETEctor<n>[:FUNction]:AUTO <State>

This command couples and decouples the detector to the trace mode.

Parameter

<State>

ON | OFF

Example

```
DET:AUTO OFF
```

Turns off automatic detector selection.

Characteristics

*RST value: ON

SCPI: conform

TRACe<n>[:DATA]? <Destination>

This command queries the trace data of the current measurement.

It also transfers data from a file to a particular trace.

With `FORMat [:DATA] <DataFormat>` command, you can set the data format.

Parameter

<Destination>

TRACE1	Queries the data of trace 1.
TRACE2	Queries the data of trace 2.
LIST	Queries the peak list of the measurement.

Return value

The R&S FSH returns 631 values. Each value corresponds to one pixel of a trace.

The unit depends on the measurement and the unit you have set with `UNIT<n>:POWer <Unit>`.

Note:

If you use the auto peak detector, the command reads out positive peak values only.

Example

```
TRAC:DATA? TRACE1
```

Reads out the data for trace 1

Characteristics

*RST value: -
SCPI: conform

TRACe<n>:DATA:MEMory? <Trace>

This command queries the memory trace data.

You can set the data format with the `FORMat[:DATA] <DataFormat>`.

To query memory trace data, you have to create a memory trace first with `DISPlay[:WINDow]:TRACe<n>:MEMory[:STATe] <State>`.

Parameter

<Trace>

TRACE1	Queries the data of memory trace 1.
TRACE2	Queries the data of memory trace 2.
TRACE3	Queries the data of memory trace 3.
TRACE4	Queries the data of memory trace 4.

Only traces that are actually in the trace memory can be exported.

Return value

The R&S FSH returns 631 values. Each value corresponds to one pixel of a trace.

The result and unit depends on the measurement format.

Example

```
DISP:TRAC2:MODE AVER
CALC:MATH2:COPY:MEM
TRAC:DATA:MEM? TRACE1
```

Reads out the data for memory trace 1.

Characteristics

*RST value: -
SCPI: conform

FORMat[:DATA] <DataFormat>

This command selects the data format that is used for transmission of trace data from the R&S FSH to the controlling computer.

Note that the command has no effect for data that you send to the R&S FSH. The R&S FSH automatically recognizes the data it receives, regardless of the format.

Parameter

<DataFormat>

ASCIi	Returns the data in ASCII format, separated by commas.
REAL,32	Returns the data as 32-bit IEEE 754 floating point numbers in the "definite length block format".

In REAL,32 format, a string of return values would look like:

```
#42524<value 1><value 2>...<value n>
```

with

#4 Number of digits of the following number of data bytes (= 4 in this example)
2524 Number of following data bytes (2524, corresponds to the 631 sweep points of the R&S FSH).
<value> 4-byte floating point value

Example

```
FORM ASC
```

Selects the ASCII data format.

Characteristics

*RST value: ASCIi
SCPI: conform

7.2.6 Using Markers

- [Markers and Delta Markers](#) on page 66
- [Marker Functions](#) on page 74

7.2.6.1 Markers and Delta Markers

The following commands are for setting and controlling markers and deltamarkers.

In spectrum mode, the suffix <n> at CALCulate selects the trace. Its range is {1..2}.

The suffix <m> at MARKer is in the range {1..6} and selects the marker or deltamarker.

List of commands

- [CALCulate<n>:DELTamarker<m>\[:STATe\] <State>](#) (p. 66)
- [CALCulate<n>:DELTamarker<m>:AOFF](#) (p. 67)
- [CALCulate<n>:DELTamarker<m>:MAXimum\[:PEAK\]](#) (p. 67)
- [CALCulate<n>:DELTamarker<m>:MAXimum:NEXT](#) (p. 67)
- [CALCulate<n>:DELTamarker<m>:MINimum\[:PEAK\]](#) (p. 68)
- [CALCulate<n>:DELTamarker<m>:X <Coordinate>](#) (p. 68)
- [CALCulate<n>:DELTamarker<m>:X:RELative <Distance>](#) (p. 69)
- [CALCulate<n>:DELTamarker<m>:Y?](#) (p. 69)
- [CALCulate<n>:MARKer<m>\[:STATe\] <State>](#) (p. 70)
- [CALCulate<n>:MARKer<m>:AOFF](#) (p. 70)
- [CALCulate<n>:MARKer<m>:MAXimum\[:PEAK\]](#) (p. 70)
- [CALCulate<n>:MARKer<m>:MAXimum:NEXT](#) (p. 71)
- [CALCulate<n>:MARKer<m>:MINimum\[:PEAK\]](#) (p. 71)
- [CALCulate<n>:MARKer<m>:X <Coordinate>](#) (p. 71)
- [CALCulate<n>:MARKer<m>:X:SLIMits\[:STATe\] <State>](#) (p. 72)
- [CALCulate<n>:MARKer<m>:X:SLIMits:LEFT <SearchLimit>](#) (p. 72)
- [CALCulate<n>:MARKer<m>:X:SLIMits:RIGHT <Searchlimit>](#) (p. 73)
- [CALCulate<n>:MARKer<m>:Y?](#) (p. 73)

CALCulate<n>:DELTamarker<m>[:STATe] <State>

This command turns delta markers on and off.

If you set the suffix at DELTmarker to 1, or use no suffix, the R&S FSH interprets this as delta marker 2 because the first marker has to be a normal marker. If more than one normal marker (2 to 6) are already active, the command turns these marker into delta markers. If no delta marker is active yet, the command activates the delta marker and positions it on the trace maximum.

Parameter

<State>
ON | OFF

Example

```
CALC:DELT3 ON
```

Turns delta marker 3 on or turn marker 3 into a delta marker.

Characteristics

RST value: OFF
SCPI: device-specific

CALCulate<n>:DELTamarker<m>:AOFF

This command turns off all active delta markers.

This command is an event and therefore has no query and no *RST value.

Example

```
CALC:DELT:AOFF
```

Turns off all delta markers.

Characteristics

RST value: –
SCPI: device-specific

CALCulate<n>:DELTamarker<m>:MAXimum[:PEAK]

This command positions a delta marker on the current trace maximum.

If necessary, the corresponding delta marker is activated first.

This command is an event and therefore has no *RST value and no query.

Example

```
CALC:DELT3:MAX
```

Moves delta marker 3 to the maximum peak.

Characteristics

RST value: –
SCPI: device-specific

CALCulate<n>:DELTamarker<m>:MAXimum:NEXT

This command positions a delta marker on the next smaller trace maximum.

If necessary, the corresponding delta marker is activated first.

This command is an event and therefore has no *RST value and no query.

Example

```
CALC:DELT2:MAX:NEXT
```

Moves delta marker 2 to the next smaller maximum peak.

Characteristics

RST value: –
SCPI: device-specific

CALCulate<n>:DELTamarker<m>:MINimum[:PEAK]

This command positions a delta marker on the current trace minimum.

If necessary, the corresponding delta marker is activated first.

This command is an event and therefore has no *RST value and no query.

Example

```
CALC:DELT3:MIN
```

Moves delta marker 3 to the trace minimum.

Characteristics

RST value: –

SCPI: device-specific

CALCulate<n>:DELTamarker<m>:X <Coordinate>

This command positions a delta marker on a particular coordinate on the horizontal axis.

Note that it is possible to place the marker outside the visible trace. In that case, this value is invalid.

If necessary, the corresponding delta marker is activated first.

Parameter

<Coordinate>

Numeric value that indicates the coordinate on the horizontal axis.

The range corresponds to the maximum span.

The unit depends on the measurement, e.g. Hz for measurements in the frequency domain and seconds for measurements in the time domain.

Example

```
CALC:DELT:MOD REL
```

Delta marker positions are relative to marker 1.

```
CALC:DELT2:X 10.7MHz
```

Positions delta marker 2 10.7 MHz to the right of marker 1.

```
CALC:DELT2:X?
```

```
CALC:DELT2:X:REL?
```

Queries the absolute and relative position of delta marker 2.

Characteristics

RST value: –

SCPI: device-specific

CALCulate<n>:DELTaMarker<m>:X:RELative <Distance>

This command positions a delta marker on a position relative to the reference marker.

If necessary, the corresponding delta marker is activated first.

Parameter

<Distance>

Numeric value that defines the distance of the marker to the reference marker

The range depends on the current scaling of the horizontal axis.

The unit depends on the measurement, e.g. Hz for measurements in the frequency domain and seconds for measurements in the time domain.

Example

```
CALC:DELT3:X:REL 5 kHz
```

Sets the delta marker at a distance of 5 kHz to the reference position.

Characteristics

RST value: –

SCPI: device-specific

CALCulate<n>:DELTaMarker<m>:Y?

This command queries the vertical position of a delta marker. The result is always a relative value in relation to marker 1.

If necessary, the corresponding delta marker is activated first.

To get a valid result, you have to perform a complete sweep with synchronization to the sweep end between activating the delta marker and reading out the result. This is only possible in single sweep mode.

Return value

<MarkerPosition>

In spectrum analyzer mode, the unit depends on the unit you have set and the scaling of the vertical axis.

Parameter or measuring functions	Output unit
DBM DBPW DBUV DBMV DBUA	dB (lin/log)
WATT VOLT AMPere	dB (lin), % (log)

Example

```
INIT:CONT OFF
```

```
CALC:DELT2 ON
```

Turns on single sweep mode and delta marker 2.

```
INIT;*WAI
```

Starts a sweep and waits for its end.

CALC:DELT2:Y?

Queries the position of delta marker 2.

Characteristics

RST value: –

SCPI: device-specific

CALCulate<n>:MARKer<m>[:STATe] <State>

This command turns markers on and off.

If you do not use a suffix at MARKer, marker 1 is selected. If one or more delta markers (2 to 6) are already active, the command turns these delta markers into normal markers.

Parameter

<State>

ON | OFF

Example

CALC:MARK3 ON

Turns on marker 3.

Characteristics

*RST value: OFF

SCPI: device-specific

CALCulate<n>:MARKer<m>:AOFF

This command turns off all active markers, delta markers and active marker measurement functions.

This command is an event and therefore has no query and no *RST value.

Example

CALC:MARK:AOFF

Switches off all markers.

Characteristics

*RST value: –

SCPI: device-specific

CALCulate<n>:MARKer<m>:MAXimum[:PEAK]

This command positions a marker on the current trace maximum.

If necessary, the corresponding marker is activated first.

This command is an event and therefore has no *RST value and no query.

Example

```
CALC:MARK2:MAX
```

Moves marker 2 to the maximum peak.

Characteristics

*RST value: –

SCPI: device-specific

CALCulate<n>:MARKer<m>:MAXimum:NEXT

This command positions a marker on the next smaller trace maximum.

If necessary, the corresponding marker is activated first.

This command is an event and therefore has no *RST value and no query.

Example

```
CALC:MARK2:MAX:NEXT
```

Moves marker 2 to the next smaller maximum peak.

Characteristics

*RST value: –

SCPI: device-specific

CALCulate<n>:MARKer<m>:MINimum[:PEAK]

This command positions a marker on the current trace minimum.

If necessary, the corresponding marker is activated first.

This command is an event and therefore has no *RST value and no query.

Example

```
CALC:MARK2:MIN
```

Moves marker 2 to the trace minimum.

Characteristics

*RST value: –

SCPI: device-specific

CALCulate<n>:MARKer<m>:X <Coordinate>

This command positions a marker on a particular coordinate on the horizontal axis.

If one or more delta markers (2 to 6) are already active, the command turns these delta markers into normal markers.

Note that it is possible to place the marker outside the visible trace. In that case, this value is invalid.

If necessary, the corresponding delta marker is activated first.

Parameter

<Coordinate>

Numeric value indicating the coordinate on the horizontal axis.

The range corresponds to the maximum span.

The unit in spectrum analyzer mode depends on the measurement, e.g. Hz for measurements in the frequency domain and seconds for measurements in the time domain.

Example

CALC:MARK2:X 10.7MHz

Positions marker 2 to frequency 10.7 MHz.

Characteristics

*RST value: –

SCPI: device-specific

CALCulate<n>:MARKer<m>:X:SLIMits[:STATe] <State>

 This command turns marker search limits on and off.

If you perform a measurement in zero span, this command, this command limits the evaluation range on the trace.

The numeric suffix at MARKer is irrelevant.

Parameter

<State>

ON | OFF

ExampleSee [CALCulate<n>:MARKer<m>:X:SLIMits:RIGHT <Searchlimit>](#).**Characteristics**

*RST value: OFF

SCPI: device-specific

CALCulate<n>:MARKer<m>:X:SLIMits:LEFT <SearchLimit>

 This command defines the left limit of the marker search range.
To use the command, you first have to turn on search limits with [CALCulate<n>:MARKer<m>:X:SLIMits\[:STATe\] <State>](#).

If you perform a measurement in zero span, this command, this command limits the evaluation range on the trace.

The numeric suffix at MARKer is irrelevant.

Parameter

<SearchLimit>

Numeric value that sets the left marker search limit.

The value range corresponds to the maximum span.

The unit in spectrum analyzer mode depends on the measurement, e.g. Hz for measurements in the frequency domain and seconds for measurements in the time domain.

Example

See `CALCulate<n>:MARKer<m>:X:SLIMits:RIGHT <Searchlimit>`.

Characteristics

*RST value: – (is set to the left diagram border when switching on search limits)

SCPI: device-specific

CALCulate<n>:MARKer<m>:X:SLIMits:RIGHT <Searchlimit>

This command defines the right limit of the marker search range.

To use the command, you first have to turn on search limits with `CALCulate<n>:MARKer<m>:X:SLIMits[:STATe] <State>`.

If you perform a measurement in zero span, this command, this command limits the evaluation range on the trace.

The numeric suffix at MARKer is irrelevant.

Parameter

<SearchLimit>

Numeric value that sets the right marker search limit.

The value range corresponds to the maximum span.

The unit depends on the measurement, e.g. Hz for measurements in the frequency domain and seconds for measurements in the time domain.

Example

```
CALC:MARK:X:SLIM ON
```

```
CALC:MARK:X:SLIM:LEFT 10MHz
```

```
CALC:MARK:X:SLIM:RIGH 100MHz
```

Turns search limits on and defines a search range from 10 MHz to 100 MHz.

Characteristics

*RST value: – (is set to the right diagram border when switching on search limits)

SCPI: device-specific

CALCulate<n>:MARKer<m>:Y?

This command queries the absolute vertical position of a marker.

If necessary, the corresponding marker is activated first.

To get a valid result, you have to perform a complete sweep with synchronization to the sweep end between activating the delta marker and reading out the result.

This is only possible in single sweep mode.

Return values

<MarkerPosition>
 numeric value of the marker position

In spectrum mode, the unit depends on `UNIT<n>:POWER`.

Example

```
INIT:CONT OFF
CALC:MARK2 ON
```

Turns on single sweep mode and marker 2.

```
INIT;*WAI
```

Starts a sweep and waits for the end.

```
CALC:MARK2:Y?
```

Queries the position of marker 2.

Characteristics

*RST value: –
 SCPI: device-specific

7.2.6.2 Marker Functions

The following commands perform various kinds of analysis at the marker position.

The suffix <m> at MARKer is irrelevant, except where noted.

List of commands

- [CALCulate:MARKer<m>:COUNT:FREQUENCY? \(p. 75\)](#)
- [CALCulate:MARKer<m>:COUNT:RESolution:MODE <Resolution> \(p. 75\)](#)
- [CALCulate:MARKer<m>:COUNT\[:STATe\] <State> \(p. 75\)](#)
- [CALCulate:MARKer<m>:FREQUENCY:MODE <InputMode> \(p. 76\)](#)
- [CALCulate:MARKer<m>:FUNCTION:CENTer \(p. 77\)](#)
- [CALCulate:MARKer<m>:FUNCTION:DEModulation\[:STATe\] <State> \(p. 77\)](#)
- [CALCulate:MARKer<m>:FUNCTION:DEModulation:HOLDoff <Time> \(p. 77\)](#)
- [CALCulate:MARKer<m>:FUNCTION:DEModulation:SElect <Demodulation> \(p.78\)](#)
- [CALCulate:MARKer<m>:FUNCTION:NDBDown <Distance> \(p. 78\)](#)
- [CALCulate:MARKer<m>:FUNCTION:NDBDown:FREQUENCY? \(p. 78\)](#)
- [CALCulate:MARKer<m>:FUNCTION:NDBDown:RESult? \(p. 79\)](#)
- [CALCulate:MARKer<m>:FUNCTION:NDBDown:STATe <State> \(p. 79\)](#)
- [CALCulate:MARKer<m>:FUNCTION:NOISe\[:STATe\] <State> \(p. 80\)](#)
- [CALCulate:MARKer<m>:FUNCTION:NOISe:RESult? \(p. 80\)](#)
- [CALCulate:MARKer<m>:FUNCTION:REFerence \(p. 81\)](#)

CALCulate:MARKer<m>:COUNT:FREQUENCY?

This command performs a frequency measurement at the marker position and returns the result.

To get a valid result, you have to perform a complete sweep with synchronization to the sweep end to make sure that the R&S FSH actually reaches the frequency you want to measure. This is only possible in single sweep mode.

Before you can use the command, you have to turn on the frequency counter with `CALCulate:MARKer<m>:COUNT[:STATe] <State>`.

Example

See `CALCulate:MARKer<m>:COUNT[:STATe] <State>`.

Characteristics

*RST value: –
SCPI: device-specific

CALCulate:MARKer<m>:COUNT:RESolution:MODE <Resolution>

This command selects the resolution of the frequency counter.

Parameter

<State>
HIGH | LOW

Parameter

<Resolution>

HIGH	Frequency counter resolution 0.1 mHz.
LOW	Frequency counter resolution: 0.1 Hz.

Example

See `CALCulate:MARKer<m>:COUNT[:STATe] <State>`.

Characteristics

*RST value: –
SCPI: device-specific

CALCulate:MARKer<m>:COUNT[:STATe] <State>

This command turns the frequency counter at the marker position on and off.

You can read out the result with `CALCulate:MARKer<m>:COUNT:FREQUENCY?`.

Frequency counting is possible only for one marker at a time. If it is activated for another marker, it is automatically deactivated for the previous marker.

To get a valid result, you have to perform a complete sweep with synchronization to the sweep end to make sure that the R&S FSH actually reaches the frequency you want to measure. This is only possible in single sweep mode.

The suffix <m> selects the marker.

Parameter

<State>
ON | OFF

Example

```
INIT:CONT OFF
CALC:MARK ON
```

Turns on single sweep mode and marker 1.

```
CALC:MARK:COUN:RES:MODE HIGH
```

Selects the resolution of the frequency counter for marker 1.

```
CALC:MARK:COUN ON
```

Turns on the frequency counter for marker 1.

```
INIT;*WAI
```

```
CALC:MARK:COUN:FREQ?
```

Performs a measurement and queries the results of the frequency counter.

Characteristics

*RST value: OFF

SCPI: device-specific

CALCulate:MARKer<m>:FREQuency:MODE <InputMode>

This command selects the marker frequency display mode.

Parameter

<InputMode>

FREQuency	Sets the marker frequency mode to frequency input (in Hz).
CHANnel	Sets the marker frequency mode to channel input (as a channel number).

Example

```
CALC:MARK:FREQ:MODE FREQ
```

Selects the frequency display mode.

Characteristics

*RST value: FREQ

SCPI: device-specific

CALCulate:MARKer<m>:FUNCtion:CENTer

This command matches the center frequency to the frequency of a marker

If you use a delta marker, the R&S FSH turns it into a normal marker.

The suffix <m> selects the marker.

This command is an event and therefore has no *RST value and no query.

Example

```
CALC:MARK1:FUNC:CENT
```

Matches the center frequency to the frequency of marker 1.

Characteristics

*RST value: -

SCPI: device-specific

CALCulate:MARKer<m>:FUNCtion:DEModulation[:STATE] <State>

This command turns the audio demodulator on and off when the measurement hits a marker position.

With a span greater than 0, you can define a hold time at the marker position with `CALCulate:MARKer<m>:FUNCtion:DEModulation:HOLDoff <Time>`.

In zero span the demodulation is on permanently.

Parameter

<State>

ON | OFF

Example

```
CALC:MARK3:FUNC:DEM ON
```

Switches on the demodulation for marker 3.

Characteristics

*RST value: OFF

SCPI: device-specific

CALCulate:MARKer<m>:FUNCtion:DEModulation:HOLDoff <Time>

This command defines the hold time at the marker position for the demodulation with span > 0.

Parameter

<Time>

Numeric value in the range from 10 ms to 500 s.

Example:

```
CALC:MARK:FUNC:DEM:HOLD 3s
```

Sets a hold time of 3 seconds.

Characteristics:

*RST value: – (DEModulation is set to OFF)

SCPI: device-specific

CALCulate:MARKer<m>:FUNCtion:DEModulation:SElect <Demodulation>

This command selects the type of demodulation type for the audio demodulator.

Parameter

<Demodulation>

AM | FM

Example

```
CALC:MARK:FUNC:DEM:SEL FM
```

Selects FM demodulation.

Characteristics

*RST value: AM

SCPI: device-specific

CALCulate:MARKer<m>:FUNCtion:NDBDown <Distance>

This command defines the distance of the n dB down markers to the reference marker.

Parameter

<Distance>

Distance of the temporary markers to the reference marker in dB.

Example

See `CALCulate:MARKer<m>:FUNCtion:NDBDown:STATE <State>`

Characteristics

*RST value: 3 dB

SCPI: device-specific

CALCulate:MARKer<m>:FUNCtion:NDBDown:FREQUency?

This command queries the horizontal position of the n dB down markers.

Return value

<frequency1>	Absolute frequency of the n dB marker to the left of the reference marker in Hz.
<frequency2>	Absolute frequency of the n dB marker to the right of the reference marker in Hz.

Example

See `CALCulate:MARKer<m>:FUNCtion:NDBDown:STATE <State>`

Characteristics

*RST value: -
 SCPI: device-specific

CALCulate:MARKer<m>:FUNCtion:NDBDown:RESult?

This command queries the frequency spacing or bandwidth of the n dB down markers.

Return value

<Bandwidth>
 Bandwidth in Hz.

Example

See `CALCulate:MARKer<m>:FUNCtion:NDBDown:STATe <State>`

Characteristics

*RST value: -
 SCPI: device-specific

CALCulate:MARKer<m>:FUNCtion:NDBDown:STATe <State>

This command turns the n dB Down marker function on and off.

Parameter

<State>
 ON | OFF

Example

`CALC:MARK:FUNC:NDBD:STAT ON`
 Turns on the n dB marker function.

`CALC:MARK:FUNC:NDBD 3`
 Positions two temporary markers 3 dB below a reference marker.

`CALC:MARK:FUNC:NDBD:FREQ?`
 Queries the frequency position of the n dB Down markers; would return e.g.
 100000000,200000000

`CALC:MARK:FUNC:NDBD:RES?`
 Queries the measurement result; would return e.g.
 100000000

Characteristics

*RST value: OFF
 SCPI: device-specific

CALCulate:MARKer<m>:FUNction:NOISe[:STATe] <State>

This command turns the noise measurement for all markers on and off.

You can query the results of the noise power density at the marker position with `CALCulate:MARKer<m>:FUNction:NOISe:RESult?`.

Parameter

<State>
ON | OFF

Example

See `CALCulate:MARKer<m>:FUNction:NOISe:RESult?`.

Characteristics

*RST value: OFF
SCPI: device-specific

CALCulate:MARKer<m>:FUNction:NOISe:RESult?

This command queries the result of the noise measurement.

To get a valid result, you have to perform a complete sweep with synchronization to the sweep end before reading out the result. This is only possible in single sweep mode.

This command is an event and therefore has no *RST value and no query.

Return value

<NoiseLevel>

The unit depends on `UNIT<n>:POWER`.

Example

```
INIT:CONT OFF
Turns on single sweep mode.
```

```
CALC:MARK2 ON
CALC:MARK2:FUNC:NOIS ON
Turns on marker 2 and assigns the noise measurement to that marker.
```

```
INIT;*WAI
CALC:MARK2:NOIS:RES?
Performs the measurement and queries the noise marker results.
```

Characteristics

*RST value: –
SCPI: device-specific

CALCulate:MARKer<m>:FUNCtion:REFerence

This command matches the reference level to the power level of a marker

If you use a delta marker, the R&S FSH turns it into a normal marker.

This command is an event and therefore has no *RST value and no query.

Example

```
CALC:MARK1:FUNC:REF
```

Matches the reference level to the power level of marker 1.

Characteristics

*RST value: -

SCPI: device-specific

7.2.7 Using Display Lines and Limit Lines

7.2.7.1 Display Lines

The following commands define the position of the display line.

The suffix <n> at CALCulate selects the trace. Its range is {1..2}. Only relevant for segmented sweep.

List of commands

- [CALCulate<n>:DLINe <Amplitude>](#) (p. 82)
- [CALCulate<n>:DLINe:STATe <State>](#) (p. 82)

CALCulate<n>:DLINe <Amplitude>

This command defines the position of a display line.

Parameter

<Amplitude>

Numeric value with a variable range and unit.

You can use any unit you want, the R&S FSH then converts the unit to the currently selected unit. If you omit a unit, the R&S FSH uses the currently selected unit.

Example

```
CALC:DLIN -20dBm
```

Sets the display line threshold to -20 dBm.

Characteristics

*RST value: – (STATe to OFF)

SCPI: device-specific

CALCulate<n>:DLINe:STATe <State>

This command turns display lines on and off.

Parameter

<State>

ON | OFF

Example

```
CALC:DLIN:STAT OFF
```

Turns on the display line.

Characteristics

*RST value: OFF

SCPI: device-specific

7.2.7.2 Limit Lines

The following commands define limit lines and perform the corresponding limit checks.

The suffix <n> in the following commands selects the trace. Its range is {1..2}. Only relevant for segmented sweep.

The suffix <k> at LIMit selects the limit line and is in the range <1...2>.

List of commands

- [CALCulate<n>:LIMit<k>:BEEP\[:STATe\] <State>](#) (p. 83)
- [CALCulate<n>:LIMit<k>:COMMeNt?](#) (p. 83)
- [CALCulate<n>:LIMit<k>:DEFine](#) (p. 84)
- [CALCulate<n>:LIMit<k>:DELete](#) (p. 85)
- [CALCulate<n>:LIMit<k>:FAIL?](#) (p. 85)
- [CALCulate<n>:LIMit<k>:LOWer:SELect <LimitLine>](#) (p. 85)
- [CALCulate<n>:LIMit<k>:LOWer:THReshold <Level>](#) (p. 86)
- [CALCulate<n>:LIMit<k>:STATe <State>](#) (p. 86)
- [CALCulate<n>:LIMit<k>:UNIT:X?](#) (p. 86)
- [CALCulate<n>:LIMit<k>:UNIT\[:Y\]?](#) (p. 87)
- [CALCulate<n>:LIMit<k>:UPPer:SELect <LimitLine>](#) (p. 87)
- [CALCulate<n>:LIMit<k>:UPPer:THReshold <Level>](#) (p. 87)

CALCulate<n>:LIMit<k>:BEEP[:STATe] <State>

This command turns the beeper that beeps if a limit line is violated on and off.

Parameter

<State>
ON | OFF

Example

```
CALC:LIM:BEEP ON
Activates the audio beep.
```

Characteristics

*RST value: OFF
SCPI: device-specific

CALCulate<n>:LIMit<k>:COMMeNt?

This command queries the description of a limit line.

This command is a query and therefore has no RST value.

Return value

<Comment>
String containing the description of the limit line.

Example

```
CALC:LIM:COMM?
```

Queries the description of limit line 1.

Characteristics

*RST value: -
 SCPI: device-specific

CALCulate<n>:LIMit<k>:DEFine

```
<Name>,<Comment>,<Unit>,<Scale>,<Unit>,<x1>,<y1>[,<xn>,<yn>]
```

This command defines the shape of a limit line.

After you have defined the shape of the limit line you still have to activate it with [CALCulate<n>:LIMit<k>:UPPer:SElect <LimitLine>](#) before it takes effect.

Parameters

<Name>
 String containing the name of the limit line.

Note: if a limit line with the same name already exists, it will be overwritten.

<Comment>
 String containing a comment for the limit line.

<X-unit>
 Unit of the x-axis. HZ | S | M

<Scale>
 Scale of the x-axis: ABS | REL

<Y-unit>
 Unit of the y-axis: DB | DBM | DBUV | DBMV | DBUVM | DBUAM | VSWR | V | W

<x1>,<xn>
 Data points on the x-axis.

Note: a limit line may consist of up to 100 horizontal data points.

<y1>,<yn>
 Data points on the y-axis.

Example

```
CALC:LIM:DEF 'Line','Example',HZ,ABS,DBM,10000000,-10,
10000000,0,20000000,0
```

Defines a limit line with three data points.

Characteristics

*RST value: -
 SCPI: device-specific

CALCulate<n>:LIMit<k>:DELeTe

This command deletes a limit line.

This command is an event and therefore has no *RST value and no query.

Example

```
CALC:LIM2:DEL  
Deletes the second limit line
```

Characteristics

*RST value: -
SCPI: device-specific

CALCulate<n>:LIMit<k>:FAIL?

This command queries the result of a limit check.

To get a valid result, you have to perform a complete sweep with synchronization to the sweep end before reading out the result. This is only possible in single sweep mode.

Return value

0 for PASS and 1 for FAIL

Example

```
INIT;*WAI  
CALC:LIM1:FAIL?  
Performs a measurement and queries the result of the check for limit line 1.
```

Characteristics

*RST value: -
SCPI: conform

CALCulate<n>:LIMit<k>:LOWer:SElect <LimitLine>

This command selects the lower limit line.

This command is an event and therefore has no *RST value and no query.

Parameter

<LimitLine>
String containing the file name of the lower limit line.

Example

```
CALC:LIM:LOW:SEL 'GSM_Lower.rellim'  
Selects the lower limit line.
```

Characteristics

*RST value:
SCPI: conform

CALCulate<n>:LIMit<k>:LOWer:THReshold <Level>

This command defines the level of a lower threshold limit line.

Parameter

<Level>

Numeric value whose unit depends on the unit you have currently selected for the vertical axis.

Example

```
CALC:LIM:LOW:THR -10DBM
```

Defines a threshold of -10 dBm

Characteristics

*RST value: -

SCPI: device-specific

CALCulate<n>:LIMit<k>:STATe <State>

This command turns a limit check on and off.

You can query the result of the limit check with

[CALCulate<n>:LIMit<k>:FAIL?](#).

Parameter

<State>

ON | OFF

Example

```
CALC:LIM:STAT ON
```

Switches on the limit check for limit line 1.

Characteristics

*RST value: OFF

SCPI: conform

CALCulate<n>:LIMit<k>:UNIT:X?

This command queries the horizontal unit of a limit line.

This command is a query and therefore has no *RST value.

Example

```
CALC:LIM:UNIT:X?
```

Queries the x-unit of the first limit line.

Characteristics

*RST value: -

SCPI: device-specific

CALCulate<n>:LIMit<k>:UNIT[:Y]?

This command queries the vertical unit of a limit line.

This command is a query and therefore has no *RST value.

Example

```
CALC:LIM1:UNIT?
```

Queries the y-unit of the first limit line.

Characteristics

*RST value: -

SCPI: device-specific

CALCulate<n>:LIMit<k>:UPPer:SElect <LimitLine>

This command selects the upper limit line.

This command is an event and therefore has no *RST value and no query.

Parameter

<LimitLine>

string containing the file name of the upper limit line

Example

```
CALC:LIM:UPP:SEL 'GSM_Upper.rellim'
```

Selects the upper limit line.

Characteristics

*RST value: -

SCPI: conform

CALCulate<n>:LIMit<k>:UPPer:THReshold <Level>

This command defines the level of an upper threshold limit line.

Parameter

<Level>

Numeric value whose unit depends on the unit you have currently selected for the vertical axis.

Example

```
CALC:LIM:UPP:THR -10DBM
```

Defines a threshold of -10 dBm

Characteristics

*RST value: -

SCPI: device-specific

7.2.8 Configuring and Using Measurement Functions

The R&S FSH provides measurement functions that allow you to perform advanced measurements and can also be controlled remotely.

General measurement functions:

- [Working with Channel Tables](#) on page 88

Power measurements:

- [Power Measurements](#) on page 91
- [Measuring the Channel Power](#) on page 95
- [Measuring the Occupied Bandwidth](#) on page 96
- [TDMA Measurements](#) on page 97
- [Measuring the Adjacent Channel Leakage Ratio](#) on page 98
- [Measuring the Spectrum Emission Mask](#) on page 113
- [Measuring Spurious Emissions](#) on page 115
- [Using the Segmented Sweep](#) on page 116

Other measurements

- [Measuring the Harmonic Distortion](#) on page 110
- [Measuring the AM Modulation Depth](#) on page 112

Isotropic Antenna

- [Using an Isotropic Antenna](#) on page 117

7.2.8.1 Working with Channel Tables

Use the following commands to work with channel tables.

The suffix <n> in the following commands selects the trace. Its range is {1..2}. Only relevant for segmented sweep.

List of commands

- [\[SENSe:\]CHANnel<n> <ChannelNumber>](#) (p. 89)
- [\[SENSe:\]CHANnel:TABLE:SElect <ChannelTable>](#) (p. 89)
- [\[SENSe:\]CHANnel<n>:TABLE:SElect:DOWNlink <ChannelTable>](#) (p. 90)
- [\[SENSe:\]CHANnel<n>:TABLE:SElect:UPLink <ChannelTable>](#) (p. 90)
- [\[SENSe:\]CHANnel<n>:TABLE:SET <Direction>](#) (p. 90)

[SENSe:]CHANnel<n> <ChannelNumber>

This command selects the channel to be analyzed.

You have to set the frequency mode with `[SENSe:]FREQuency:INPut:MODE` to channel first.

Parameter

<ChannelNumber>

numeric value that selects the number of the channel to be analyzed

Example

See `[SENSe:]CHANnel:TABLE:SElect <ChannelTable>`.

Characteristics

*RST value:depends on the channel table

SCPI: conform

[SENSe:]CHANnel:TABLE:SElect <ChannelTable>

This command selects a channel table configured for the link direction you have selected with `[SENSe:]CHANnel<n>:TABLE:SET <Direction>`.

Note that if you have previously selected a channel table with `[SENSe:]CHANnel<n>:TABLE:SElect:DOWNlink <ChannelTable>` or `[SENSe:]CHANnel<n>:TABLE:SElect:UPLink <ChannelTable>`, this command replaces that file.

Parameter

<ChannelTable>

String containing the file name of the channel table.

Example

```
CHAN:TABL:SET UP
```

Selects channel table selection for uplink signals.

```
CHAN:TABL:SEL 'TV China.CHNTAB'
```

Loads the channel table with the name 'TV China' for the uplink.

```
CHAN:TABL:SEL 'TV Italy.chntab'
```

or

```
CHAN:TABL:SEL:UPL 'TV Italy.chntab'
```

Both commands replace the uplink channel table 'TV China' with 'TV Italy'.

Downlink channel tables are not affected by the commands sent so far.

```
FREQ:INP:MODE CHAN
```

```
CHAN 10
```

Select a particular uplink channel (e.g. #10) instead of a (center) frequency.

To select an additional downlink channel table, use either:

```
CHAN:TABL:SET DOWN
```

```
CHAN:TABL:SEL 'TV Italy.chntab'
```

or

```
CHAN:TABL:SEL:DOWN 'TV Italy.chntab'
```

Characteristics

*RST value: ''

SCPI: device-specific

[SENSe]:CHANnel<n>:TABLe:SElect:DOWNlink <ChannelTable>

This command selects a channel table configured for downlink signals.

Parameter

<ChannelTable>

string containing the name of the channel table.

Example

See [SENSe:]CHANnel:TABLe:SElect <ChannelTable>.

Characteristics

*RST value: ''

SCPI: device-specific

[SENSe]:CHANnel<n>:TABLe:SElect:UPLink <ChannelTable>

This command selects a channel table configured for uplink signals.

Parameter

<ChannelTable>

string containing the name of the channel table.

Example

See [SENSe:]CHANnel:TABLe:SElect <ChannelTable>.

Characteristics

*RST value: ''

SCPI: device-specific

[SENSe]:CHANnel<n>:TABLe:SET <Direction>

This command selects the link direction for measurements with channel tables.

Parameter

<Direction>

DOWN	Selects the downlink.
UP	Selects the uplink.

Example

See `[SENSe:]CHANnel:TABLE:SElect <ChannelTable>`.

Characteristics

*RST value: UP
 SCPI: device-specific

7.2.8.2 Power Measurements

The following commands configure power measurements. To perform the actual measurement, use the commands described in section "[Performing and Triggering Measurements](#)".

The suffix `<n>` in the following commands selects the trace. Its range is {1..2}. Only relevant for segmented sweep.

List of commands

- [CALCulate:MARKer:FUNCTION:POWER:SElect <Measurement>](#) (p. 91)
- [CALCulate:MARKer:FUNCTION:POWER\[:STATE\] <State>](#) (p. 92)
- [CALCulate<n>:MARKer:FUNCTION:POWER:PRESet <Standard>](#) (p. 92)
- [CALCulate<n>:MARKer:FUNCTION:POWER:PRESet:CHECK?](#) (p. 92)
- [CALCulate<n>:MARKer:FUNCTION:LEVel:ONCE](#) (p. 93)
- [CALCulate<n>:MARKer:FUNCTION:POWER:RESult? <Measurement>](#) (p. 93)

CALCulate:MARKer:FUNCTION:POWER:SElect <Measurement>

This command selects a power measurement and turns the measurement on.

Parameter

ACPower MCACpower	Adjacent Channel Leakage Ratio measurement (ACLR or ACP)
CPOWer	Chanel power measurement
OBANdwidth OBWidth	Occupied Bandwidth measurement
TDMA	TDMA power measurement

Example

```
CALC:MARK:FUNC:POW:SEL CPOW
Selects the channel power measurement
```

Characteristics

*RST value: –
 SCPI: device-specific

CALCulate:MARKer:FUNCTION:POWER[:STATe] <State>

This command turns a power measurement on and off.

You can select a power measurement with

`CALCulate:MARKer:FUNCTION:POWER:SElect <Measurement>`.

Parameter

ON	Turns the power measurement on.
OFF	Performs a basic spectrum measurement.

Example

```
CALC:MARK:FUNC:POW OFF
```

Switches off the power measurement.

Characteristics

*RST value: OFF

SCPI: device-specific

CALCulate<n>:MARKer:FUNCTION:POWER:PRESet <Standard>

This command selects one of the predefined configurations for a telecommunications standard. This command only works if you have turned on power measurements with `CALCulate:MARKer:FUNCTION:POWER[:STATe] <State>`.

The configuration for a standard is in line with the specifications and includes parameters like weighting filter, channel bandwidth and spacing, resolution and video bandwidth, as well as detector and sweep time.

Parameter

<Standard>

string containing the file name of the standard

Example

```
CALC:MARK:FUNC:POW:PRES '3GPP WCDMA.chpstd'
```

Selects the 3GPP WCDMA standard for channel power measurements.

Characteristics

*RST value: -

SCPI: device-specific

CALCulate<n>:MARKer:FUNCTION:POWER:PRESet:CHECK?

This command checks if the current settings are in line with the settings defined by the standard selected with `CALCulate<n>:MARKer:FUNCTION:POWER:PRESet <Standard>`.

Note that the command only checks those parameters that are defined by the standard.

This command is a query and therefore has no *RST value.

Return value

0	R&S FSH settings violate a standard configuration.
1	R&S FSH settings comply with the standard.

Example

```
CALC:MARK:FUNC:POW:PRES:CHEC?
```

Queries compliance to the standard currently in use.

Characteristics

*RST value: -

SCPI: device-specific

CALCulate<n>:MARKer:FUNCtion:LEVel:ONCE

This command adjusts the reference level to the measured signal power.

This automatic routine makes sure that the that the signal power level does not overload the R&S FSH or limit the dynamic range by too small a S/N ratio.

To determine the best reference level, the R&S FSH aborts current measurements and performs a series of test sweeps. After it has finished the test, it continues with the actual measurement.

This command is an event and therefore has no *RST value and no query.

Example

```
CALC:MARK:FUNC:LEV:ONCE
```

Initiates an automatic level adjust routine.

Characteristics

*RST value: -

SCPI: device-specific

CALCulate<n>:MARKer:FUNCtion:POWer:RESult? <Measurement>

This command queries the results of power measurements.

To get a valid result, you have to perform a complete sweep with synchronization to the sweep end before reading out the result. This is only possible in single sweep mode.

Before you can use this command, you have to select the power measurement with `CALCulate:MARKer:FUNCtion:POWer:SElect <Measurement>` and activate it with `CALCulate:MARKer:FUNCtion:POWer[:STATe] <State>`.

This command is a query and therefore has no *RST value.

Parameter and return value

ACPower MCACpower	<p>Returns the results for ACLR measurements</p> <p>The number of return values depends on the number of TX and adjacent channel. The order of return values is:</p> <ul style="list-style-type: none"> – power of the transmission channel – power of the lower adjacent channel – power of the upper adjacent channel – power of the lower alternate channel 1 – power of the upper alternate channel 2 – etc. <p>The unit of the return values depends on the scaling of the vertical axis:</p> <ul style="list-style-type: none"> – logarithmic scaling returns the power in the currently selected unit (see UNIT<n>:POWer). – linear scaling returns the power in W.
CPOWer	<p>Returns the results for channel power measurements</p> <p>The return value is the power of the channel. The unit depends on the scaling of the vertical axis:</p> <ul style="list-style-type: none"> – logarithmic scaling returns the power in the currently selected unit (see UNIT<n>:POWer). – linear scaling returns the power in W.
OBANdwidth OBWidth	<p>Returns the results for measurements of the occupied bandwidth.</p> <p>The return value is the occupied bandwidth in Hz.</p>
TDMA	<p>Returns the results for TDMA power measurements.</p> <p>The return value is the power of the signal. The unit depends on the scaling of the vertical axis:</p> <ul style="list-style-type: none"> – logarithmic scaling returns the power in the currently selected unit (see UNIT<n>:POWer). – linear scaling returns the power in W.

Example of occupied bandwidth measurement

```
POW:BAND 90PCT
```

Defines the occupied bandwidth (90%).

```
INIT:CONT OFF
```

```
INIT;*WAI
```

```
CALC:MARK:FUNC:POW:RES? OBW
```

Turns on single sweep mode, performs a measurement and queries the results.

Characteristics

*RST value: -

SCPI: device-specific

7.2.8.3 Measuring the Channel Power

The following commands configure channel power measurements. To perform the actual measurement, use the commands described in section "[Performing and Triggering Measurements](#)".

The suffix <m> at MARKer is irrelevant.

The suffix <n> in the following commands selects the trace. Its range is {1..2}. Only relevant for segmented sweep.

List of commands

- [CALCulate<n>:MARKer<m>:FUNCTION:CPOWER:BANDwidth <Bandwidth>](#) (p. 95)
- [CALCulate<n>:MARKer<m>:FUNCTION:CPOWER:MODE <DisplayMode>](#) (p. 95)
- [CALCulate<n>:MARKer<m>:FUNCTION:CPOWER:UNIT <Unit>](#) (p. 96)
- [CALCulate<n>:MARKer<m>:FUNCTION:POWER:RESult:PHZ <State>](#) (p. 96)

CALCulate<n>:MARKer<m>:FUNCTION:CPOWER:BANDwidth <Bandwidth>

This command defines the channel bandwidth for channel power measurements.

Parameter

<Bandwidth>
Numeric value in Hz.

Example

```
CALC:MARK:FUNC:CPOW:BAND 4 MHZ
```

Sets the channel bandwidth to 4 MHz.

Characteristics

*RST value: 3.84 MHz
SCPI: device-specific

CALCulate<n>:MARKer<m>:FUNCTION:CPOWER:MODE <DisplayMode>

This command selects the display mode for channel power measurements.

Parameter

<DisplayMode>

CLR	Displays the currently measured value (Clear / Write).
MAX	Displays the highest measured value (Max Hold).

Example

```
CALC:MARK:FUNC:CPOW:MODE CLR
```

Selects clear/write trace mode

Characteristics

*RST value: CLR
SCPI: device-specific

CALCulate<n>:MARKer<m>:FUNCtion:CPOWER:UNIT <Unit>

This command selects the unit of the vertical axis for channel power measurements.

Parameter

<Unit>
DBM | DBMV | DBUV | VOLT | WATT | V | W

Example

```
CALC:MARK:FUNC:CPOW:UNIT DBM
```

Sets the unit to dBm.

Characteristics

*RST value: dBm
SCPI: device-specific

CALCulate<n>:MARKer<m>:FUNCtion:POWER:RESult:PHZ <State>

This command turns the display of the channel power per Hertz on and off.

Parameter

ON | OFF

Example

```
CALC:MARK:FUNC:POW:RES:PHZ ON
```

Displays the measured Channel Power / Hz.

Characteristics

*RST value: dBm
SCPI: device-specific

7.2.8.4 Measuring the Occupied Bandwidth

The following commands configure the measurement of the Occupied Bandwidth. To perform the actual measurement, use the commands described in section "[Performing and Triggering Measurements](#)".

The suffix <m> at MARKer is irrelevant.

The suffix <n> in the following commands selects the trace. Its range is {1..2}. Only relevant for segmented sweep.

List of commands

- [CALCulate<n>:MARKer<m>:FUNCtion:OBAN:BANDwidth <Bandwidth>](#) (p. 97)
- [CALCulate<n>:MARKer<m>:FUNCtion:OBAN:BANDwidth:PCT <OBW>](#) (p. 97)

CALCulate<n>:MARKer<m>:FUNCtion:OBAN:BANDwidth <Bandwidth>

This command defines the channel bandwidth for occupied bandwidth measurements.

Instead of OBANwidth, you can also use the alias OBWidth

Parameter

<Bandwidth
Numeric value in Hz.

Example

```
CALC:MARK:FUNC:OBW:BAND 1 MHZ
```

Sets the channel bandwidth to 1 MHz

Characteristics

*RST value: 3.84 MHz
SCPI: device-specific

CALCulate<n>:MARKer<m>:FUNCtion:OBAN:BANDwidth:PCT <OBW>

This command defines the percentage of the total power that defines the occupied bandwidth.

Instead of OBANwidth, you can also use the alias OBWidth

Parameter

<Percentage>
Numeric value in the range from 10% to 99.9%.

Example

```
CALC:MARK:FUNC:OBW:BAND:PCT 95
```

Sets the power percentage to 95%

Characteristics

*RST value: 99%
SCPI: device-specific

7.2.8.5 TDMA Measurements

The following commands configure TDMA measurements. To perform the actual measurement, use the commands described in section "[Performing and Triggering Measurements](#)".

The suffix <m> at MARKer is irrelevant.

List of commands

- [CALCulate:MARKer<m>:FUNCtion:TDMA:BURSt <BurstLength>](#) (p. 98)

CALCulate:MARKer<m>:FUNction:TDMA:BURSt <BurstLength>

This command defines the burst length of the TDMA signal.

Parameter

<BurstLength>
Numeric value in seconds.

The value range depends on the current sweep time.

Example

```
CALC:MARK:FUNC:TDMA:BURS 80 US
```

Sets the burst length to 80 us.

Characteristics

*RST value: 470 us
SCPI: device-specific

7.2.8.6 Measuring the Adjacent Channel Leakage Ratio

The following commands configures Adjacent Channel Leakage Ratio (ACLR) measurements. To perform the actual measurement, use the commands described in section "[Performing and Triggering Measurements](#)".

The suffix <y> selects one of the 11 alternate channels. The range is <1...11>.

The suffix <k> at LIMit is irrelevant.

- [Configuring and Performing the ACLR Measurement](#) on page 98
- [ACLR Limit Check](#) on page 104

Configuring and Performing the ACLR Measurement

The following commands configure and perform the ACLR measurements.

List of commands

- [CALCulate:MARKer:FUNction:ACPower:UNIT <Unit>](#) (p. 99)
- [\[SENSe:\]POWer:ACHannel:ACPairs <ChannelPairs>](#) (p. 99)
- [\[SENSe:\]POWer:ACHannel:BANDwidth\[:CHANnel\] <Bandwidth>](#) (p. 99)
- [\[SENSe:\]POWer:ACHannel:BANDwidth:ACHannel <Bandwidth>](#) (p. 100)
- [\[SENSe:\]POWer:ACHannel:BANDwidth:ALTErnate<y> <Bandwidth>](#) (p. 100)
- [\[SENSe:\]POWer:ACHannel:MODE <PowerMode>](#) (p. 100)
- [\[SENSe:\]POWer:ACHannel:PRESet:RLEVel](#) (p. 101)
- [\[SENSe:\]POWer:ACHannel:REFerence:TXCHannel:AUTO <RefChannel>](#) (p. 101)
- [\[SENSe:\]POWer:ACHannel:REFerence:TXCHannel:MANual <RefChannel>](#) (p. 102)
- [\[SENSe:\]POWer:ACHannel:SPACing\[:ACHannel\]](#) (p. 102)
- [\[SENSe:\]POWer:ACHannel:SPACing:ALTErnate<y> <Spacing>](#) (p. 103)
- [\[SENSe:\]POWer:ACHannel:SPACing:CHANnel<Tx> <Spacing>](#) (p. 103)
- [\[SENSe:\]POWer:ACHannel:TXCHannel:COUNt <TxChannels>](#) (p. 103)

CALCulate:MARKer:FUNCtion:ACPower:UNIT <Unit>

This command selects the unit of the ACLR results.

Parameter

<Unit>
DBM | DBMV | DBUV | VOLT | WATT

Example

```
CALC:MARK:FUNC:ACP:UNIT DBM
```

ACLR results are converted into the unit dBm.

Characteristics

*RST value: 1
SCPI: device-specific

[SENSe:]POWer:ACHannel:ACPairs <ChannelPairs>

This command defines the number of pairs of adjacent channels.

Parameter

<ChannelPairs>
Numeric value in the range from 1 to 12.

The number corresponds to a pair of adjacent channels, one channel on the left and one on the right of the transmission channel.

Example

```
See [SENSe:]POWer:ACHannel:TXChannel:COUNT <TxChannels>
```

Characteristics

*RST value: 1
SCPI: device-specific

[SENSe:]POWer:ACHannel:BANDwidth[:CHANnel] <Bandwidth>

This command defines the channel bandwidth of the transmission channels.

Instead of BANDwidth, you can also use the alias BWIDth

Parameter

<Bandwidth>
Numeric value in Hz.

Example

```
See [SENSe:]POWer:ACHannel:TXChannel:COUNT <TxChannels>
```

Characteristics

*RST value: 14 kHz
SCPI: device-specific

[SENSe:]POWer:ACHannel:BANDwidth:ACHannel <Bandwidth>

This command defines the channel bandwidth of the adjacent channel.

The adjacent channel is the first pair of channels next to the transmission channels. If you set the channel bandwidth for these channels, the R&S FSH sets the bandwidth of the alternate channels to the same value.

Instead of BANDwidth, you can also use the alias BWIDth

Parameter

<Bandwidth>
Numeric value in Hz.

Example

See `[SENSe:]POWer:ACHannel:TXChannel:COUNT <TxChannels>`

Characteristics

*RST value: 14 kHz
SCPI: device-specific

[SENSe:]POWer:ACHannel:BANDwidth:ALternate<y> <Bandwidth>

This command defines the bandwidth of the alternate channels.

If you set the channel bandwidth for the first alternate channel, the R&S FSH sets the bandwidth of the other alternate channels to the same value. The command works hierarchically: to set a bandwidth of the 10th and 8th channel, you have to set the bandwidth of the 8th channel first.

Instead of BANDwidth, you can also use the alias BWIDth

Parameter

<Bandwidth>
Numeric value in Hz.

Example

See `[SENSe:]POWer:ACHannel:TXChannel:COUNT <TxChannels>`

Characteristics

*RST value: 14 kHz
SCPI: device-specific

[SENSe:]POWer:ACHannel:MODE <PowerMode>

This command selects the way the R&S FSH displays the power of adjacent channels.

The number of adjacent and alternate channels has to be greater than 0 for the command to work.

Parameter

<PowerMode>

ABSolute	Shows the absolute power of all channels..
RELative	Shows the power of adjacent and alternate channels in relation to the transmission channel.

Example

```
POW:ACH:MODE ABS
```

Shows absolute powers for all channels.

Characteristics

*RST value

SCPI: device-specific

[SENSe:]POWer:ACHannel:PRESet:RLEVel

This command adjusts the reference level to the measured signal power.

This automatic routine makes sure that the that the signal power level does not overload the R&S FSH or limit the dynamic range by too small a S/N ratio.

To determine the best reference level, the R&S FSH aborts current measurements and performs a series of test sweeps. After it has finished the test, it continues with the actual measurement.

This command is an event and therefore has no *RST value and no query.

Example

```
POW:ACH:PRESet:RLEV
```

Initiates an ACP measurement and adjusts the reference level.

Characteristics

*RST value: -

SCPI: device-specific

[SENSe:]POWer:ACHannel:REFerence:TXCHannel:AUTO <RefChannel>

This command automatically selects a reference channel for relative ACLR measurements.

The number of transmission channels and adjacent / alternate channels has to be greater than 0 for the command to work.

Parameter

<RefChannel>

MINimum	Reference is the transmission channel with the lowest power.
MAXimum	Reference is the transmission channel with the highest power.
LHIGest	Reference is the lowest transmission channel for lower adjacent channels and highest transmission channel for upper adjacent channels.

Example

```
POW:ACH:REF:TXCH:AUTO MIN
```

Sets the TX channel with the lowest power as reference channel

Characteristics

*RST value

SCPI: device-specific

[SENSe:]POWer:ACHannel:REFerence:TXCHannel:MANual <RefChannel>

This command defines a reference channel for relative ACLR measurements.

The number of transmission channels and adjacent / alternate channels has to be greater than 0 for the command to work.

Parameter

<RefChannel>

Numeric value from 1 to 12.

The actual value range depends on the number of active transmission channels.

Example

See `[SENSe:]POWer:ACHannel:TXCHannel:COUnT <TxChannels>`

Characteristics

*RST value: 1

SCPI: device-specific

[SENSe:]POWer:ACHannel:SPACing[:ACHannel]] <Spacing>

This command defines the spacing between the transmission channel and its adjacent channel.

A change of the adjacent channel spacing causes a change in the spacing of all alternate channels above the adjacent channel.

Parameter

<Spacing>

Numeric value in Hz.

Example

See `[SENSe:]POWer:ACHannel:TXCHannel:COUnT <TxChannels>`

Characteristics

*RST value: 14 kHz

SCPI: device-specific

[SENSe:]POWer:ACHannel:SPACing:ALTErnate<y> <Spacing>

This command defines the spacing between alternate channels.

If you set the channel spacing for the first alternate channel, the R&S FSH sets the bandwidth of the other alternate channels to the same value. The command works hierarchically: to set a spacing of the 10th and 8th channel, you have to set the spacing of the 8th channel first.

Parameter

<Spacing>
Numeric value in Hz.

Example

See `[SENSe:]POWer:ACHannel:TXCHannel:COUNT <TxChannels>`

Characteristics

*RST value: ALT1: 40 kHz; ALT2: 60 kHz; ALT3: 80 kHz etc.
SCPI: device-specific

[SENSe:]POWer:ACHannel:SPACing:CHANnel<Tx> <Spacing>

This command defines the spacing between transmission channels.

If you set the channel spacing for the first transmission channel, the R&S FSH sets the bandwidth of the other transmission channels to the same value. The command works hierarchically: to set a spacing between the 9th and 10th and 8th and 9th channel, you have to set the spacing between the 8th and 9th channel first.

The suffix at CHANnel selects the transmission channel.

Parameter

<Spacing>
Numeric value in Hz.

Example

See `[SENSe:]POWer:ACHannel:TXCHannel:COUNT <TxChannels>`

Characteristics

*RST value: 20 kHz
SCPI: device-specific

[SENSe:]POWer:ACHannel:TXCHannel:COUNT <TxChannels>

This command defines the number of transmission channels.

The command is available for measurements with span > 0.

Parameter

<TxChannels>
Numeric value from 1 to 12.

Example

```
CALC:MARK:FUNC:POW:SEL CPOW
```

Selects the channel power measurement

```
POW:ACH:TXCH:COUN 2
```

Defines 2 transmission channels.

```
POW:ACH:ACP 2
```

Defines 2 pairs of neighboring channels to the left and right of the TX channel(s).

```
POW:ACH:SPAC:CHAN2 20KHZ
```

Defines a distance of 20 kHz between the first and the second Tx channel.

```
POW:ACH:BAND:CHAN2 120KHZ
```

Defines a bandwidth of 120 kHz for the second TX channel.

```
POW:ACH:REF:TXCH:MAN 2
```

Selects the second Tx channel as reference channel.

```
POW:ACH:SPAC 10KHZ
```

Defines a distance of 10 kHz from the TX channel to the adjacent channel.

```
POW:ACH:BAND:ACH 120KHZ
```

Defines a bandwidth of 120 kHz for the adjacent channel.

```
POW:ACH:SPAC:ALT 20KHZ
```

Defines a distance of 20 kHz from the adjacent to the first alternate channel.

```
POW:ACH:BAND:ALT 120KHZ
```

Defines a bandwidth of 120 kHz for the first alternate channel

Characteristics

*RST value: 1

SCPI: device-specific

ACLR Limit Check

The following commands configure and perform limit checks when measuring the adjacent channel power.

The suffix <k> at LIMit is irrelevant.

List of commands

- [CALCulate:LIMit<k>:ACPower\[:STATe\] <State>](#) (p. 105)
- [CALCulate:LIMit<k>:ACPower:ACHannel\[:RELative\] <Limit>](#) (p. 105)
- [CALCulate:LIMit<k>:ACPower:ACHannel\[:RELative\]:STATe <State>](#) (p. 105)
- [CALCulate:LIMit<k>:ACPower:ACHannel:ABSolute <Limit>](#) (p. 106)
- [CALCulate:LIMit<k>:ACPower:ACHannel:ABSolute:STATe <State>](#) (p. 106)
- [CALCulate:LIMit<k>:ACPower:ACHannel:RESult?](#) (p. 107)
- [CALCulate:LIMit<k>:ACPower:ALternate<y>\[:RELative\] <Limit>](#) (p. 107)
- [CALCulate:LIMit<k>:ACPower:ALternate<y>\[:RELative\]:STATe <State>](#) (p. 108)
- [CALCulate:LIMit<k>:ACPower:ALternate<y>:ABSolute <Limit>](#) (p. 108)
- [CALCulate:LIMit<k>:ACPower:ALternate<y>:ABSolute:STATe <State>](#) (p. 108)
- [CALCulate:LIMit<k>:ACPower:ALternate<y>:RESult?](#) (p. 109)

CALCulate:LIMit<k>:ACPower[:STATe] <State>

This command turns the limit check for ACLR measurements on and off.

You have to use

`CALCulate:LIMit<k>:ACPower:ACHannel[:RELative]:STATe <State>`
 or `CALCulate:LIMit<k>:ACPower:ALternate<y>[:RELative]:STATe <State>`
 in combination with this command to select the channels the limit check should be performed on.

Parameter

<State>
 ON | OFF

Example

```
CALC:LIM:ACP ON
Activates the limit check
```

Characteristics

*RST value: OFF
 SCPI: device-specific

CALCulate:LIMit<k>:ACPower:ACHannel[:RELative] <Limit>

This command defines the relative limit of the adjacent channels. The reference value for the relative limit value is the measured channel power.

Note that the relative limit has no effect on the limit check if it is below the absolute limit value (see `CALCulate:LIMit<k>:ACPower:ACHannel:ABSolute <Limit>`). This mechanism allows automatic checking of the absolute basic values of adjacent-channel power as defined in mobile radio standards.

Parameter

<Limit>
 Numeric value in the range from 0 dB to 100 dB.

Example

```
CALC:LIM:ACP:ACH 30
Defines a limit of 30 dB.
```

Characteristics

*RST value: -
 SCPI: device-specific

CALCulate:LIMit<k>:ACPower:ACHannel[:RELative]:STATe <State>

This command turns the relative limit check for the adjacent channels on and off.

You have to activate the general ACLR limit check before using this command with `CALCulate:LIMit<k>:ACPower[:STATe] <State>` first.

Parameter

<State>
ON | OFF

Example

```
CALC:LIM:ACP:ACH:STAT ON
```

Activates the relative limit check.

Characteristics

*RST value: OFF
SCPI: device-specific

CALCulate:LIMit<k>:ACPower:ACHannel:ABSolute <Limit>

This command defines the absolute limit for the adjacent channels.

Note that the absolute limit has no effect on the limit check if it is below the relative limit (see [CALCulate:LIMit<k>:ACPower:ACHannel\[:RELative\] <Limit>](#)). This mechanism allows automatic checking of the absolute basic values of adjacent-channel power as defined in mobile radio standards.

Parameter

<Limit>
Numeric value in the range from -200 dBm to 200 dBm.

Example

```
CALC:LIM:ACP:ACH:ABS -30
```

Sets the absolute limit to -30 dBm

Characteristics

*RST value: -
SCPI: device-specific

CALCulate:LIMit<k>:ACPower:ACHannel:ABSolute:STATe <State>

This command turns the absolute limit check for the adjacent channel on and off.

You have to activate the general ACLR limit check before using this command with [CALCulate:LIMit<k>:ACPower\[:STATe\] <State>](#) first.

Parameter

<State>
ON | OFF

Example

```
CALC:LIM:ACP:ACH:ABS:STAT ON
```

Activates the absolute limit check.

Characteristics

*RST value: OFF
 SCPI: device-specific

CALCulate:LIMit<k>:ACPower:ACHannel:RESult?

This command queries the result of the limit check of the adjacent channels.

To get a valid result, you have to perform a complete sweep with synchronization to the sweep end before reading out the result. This is only possible in single sweep mode.

This command is a query and therefore has no *RST value.

Return value

The return value consists of two values, one for the lower and one for the upper adjacent channel.

FAILed	Limit check failed.
PASSed	Limit check passed.

Example

```
CALC:LIM:ACP:ACH:RES?
```

Queries the limit check results. The command would return, e.g.

```
FAILED, FAILED
```

Upper and lower adjacent channels violate a limit.

Characteristics

*RST value: -
 SCPI: device-specific

CALCulate:LIMit<k>:ACPower:ALTErnate<y>[:RELative] <Limit>

This command defines the relative limit of the alternate channels. The reference value for the relative limit value is the measured channel power.

Note that the relative limit has no effect on the limit check if it is below the absolute limit value (see [CALCulate:LIMit<k>:ACPower:ALTErnate<y>:ABSolute<Limit>](#)). This mechanism allows automatic checking of the absolute basic values of adjacent-channel power as defined in mobile radio standards.

Parameter

<Limit>

Numeric value in the range from 0 dB to 100 dB.

Example

```
CALC:LIM:ACP:ALT3 30
```

Defines a limit of 30 dB for the third alternate channel.

Characteristics

*RST value: -
 SCPI: device-specific

CALCulate:LIMit<k>:ACPowEr:ALTernate<y>[:RELative]:STATe <State>

This command turns the relative limit check for an alternate channels on and off.

You have to activate the general ACLR limit check before using this command with `CALCulate:LIMit<k>:ACPowEr[:STATe] <State>` first.

Parameter

<State>
 ON | OFF

Example

```
CALC:LIM:ACP:ALT3:STAT ON
```

Activates the relative limit check for the third alternate channel.

Characteristics

*RST value: OFF
 SCPI: device-specific

CALCulate:LIMit<k>:ACPowEr:ALTernate<y>:ABSolute <Limit>

This command defines the absolute limit for the alternate channels.

Note that the absolute limit has no effect on the limit check if it is below the relative limit (see `CALCulate:LIMit<k>:ACPowEr:ALTernate<y>[:RELative] <Limit>`). This mechanism allows automatic checking of the absolute basic values of adjacent-channel power as defined in mobile radio standards.

Parameters

<Limit>
 Numeric value in the range from -200 dBm to 200 dBm.

Example

```
CALC:LIM:ACP:ALT3:ABS -30
```

Sets the absolute limit to -30 dBm for the third alternate channel.

Characteristics

*RST value: -
 SCPI: device-specific

CALCulate:LIMit<k>:ACPowEr:ALTernate<y>:ABSolute:STATe <State>

This command turns the absolute limit check for an alternate channel on and off.

You have to activate the general ACLR limit check before using this command with `CALCulate:LIMit<k>:ACPowEr[:STATe] <State>` first.

Parameter

<State>
ON | OFF

Example

CALC:LIM:ACP:ALT3:ABS:STAT ON
Activates the absolute limit check for the third alternate channel.

Characteristics

*RST value: OFF
SCPI: device-specific

CALCulate:LIMit<k>:ACPower:ALTernate<y>:RESult?

This command queries the result of the limit check of the alternate channels.

To get a valid result, you have to perform a complete sweep with synchronization to the sweep end before reading out the result. This is only possible in single sweep mode.

This command is a query and therefore has no *RST value.

Return value

The return value consists of two values, one for the lower and one for the upper alternate channel.

FAILed	Limit check failed.
PASSed	Limit check passed.

Example

CALC:LIM:ACP:ALT2:RES?
Queries the limit check results for the second alternate channels. The command would return, e.g.

FAILED, FAILED
Upper and lower alternate channels violate a limit.

Characteristics

*RST value: -
SCPI: device-specific

ACLR Result Query

The following commands query results specific to the adjacent channel power measurement.

The suffixes<n> and <m> at CALCulate and MARKer are irrelevant.

List of commands

- [CALCulate<n>:MARKer<m>:FUNction:TXPower:RESult?](#) (p. 110)

CALCulate<n>:MARKer<m>:FUNcTion:TXPower:RESult?

This command queries the total TX channel power.

(Use `CALCulate<n>:MARKer:FUNcTion:POWer:RESult? <Measurement>` to query the power of each TX channel.)

Return value

<Power>

Example

```
CALC:MARK:FUNC:TXP:RES?
```

Queries the total channel power over all TX channels.

Characteristics

*RST value: -

SCPI: device-specific

7.2.8.7 Measuring the Harmonic Distortion

The following commands configure Harmonic Distortion measurements. To perform the actual measurement, use the commands described in section "[Performing and Triggering Measurements](#)".

The numeric suffixes <n> and <m> at CALCulate and MARKer are irrelevant.

List of commands

- `CALCulate<n>:MARKer<m>:FUNcTion:HARMonics[:STATe] <State>` (p. 110)
- `CALCulate<n>:MARKer<m>:FUNcTion:HARMonics:DISToRtion?` (p. 111)
- `CALCulate<n>:MARKer<m>:FUNcTion:HARMonics:LIST?` (p. 111)
- `CALCulate<n>:MARKer<m>:FUNcTion:HARMonics:NHARMonics <Harmonics>` (p. 112)
- `CALCulate<n>:MARKer<m>:FUNcTion:HARMonics:PRESet` (p. 112)

CALCulate<n>:MARKer<m>:FUNcTion:HARMonics[:STATe] <State>

This command turns the harmonic distortion measurement on and off.

Parameter

<State>
ON | OFF

Example

See `CALCulate<n>:MARKer<m>:FUNcTion:HARMonics:PRESet`.

Characteristics

*RST value: OFF

SCPI: device-specific

CALCulate<n>:MARKer<m>:FUNction:HARMonics:DISTortion? TOTal

This command queries the total harmonic distortion of the signal.

To get a valid result, you have to perform a complete sweep with synchronization to the sweep end before reading out the result. This is only possible in single sweep mode.

This command is a query and therefore has no *RST value.

Parameter

TOTal

Return value

<Distortion%>,<DistortiondB>

Pair of values, one showing the THD in %, one in dB.

Example

See [CALCulate<n>:MARKer<m>:FUNction:HARMonics:PRESet](#).

Characteristics

*RST value: -

SCPI: device-specific

CALCulate<n>:MARKer<m>:FUNction:HARMonics:LIST?

This command queries the position of the harmonics.

To get a valid result, you should perform a complete sweep in single sweep mode before querying the results.

This command is a query and therefore has no *RST value.

Return value

Returns one value for every harmonic.

The first value is the absolute power of the first harmonic. The level unit depends on the unit you have set with the [UNIT<n>:POWer](#) command. The other values are power levels relative to the first harmonic. The unit for these is dB.

The total number of return values depends on the number of harmonics you have set with [CALCulate<n>:MARKer<m>:FUNction:HARMonics:NHARmonics<Harmonics>](#).

Example

See [CALCulate<n>:MARKer<m>:FUNction:HARMonics:PRESet](#).

Characteristics

*RST value: -

SCPI: device-specific

CALCulate<n>:MARKer<m>:FUNCtion:HARMonics:NHARmonics <Harmonics>

This command sets the number of harmonics. The valid range is from 1 to 6 harmonics.

Parameter

<Harmonics>

Numeric value in the range from 1 to 6.

Example

See `CALCulate<n>:MARKer<m>:FUNCtion:HARMonics:PRESet`.

Characteristics

*RST value: 2

SCPI: device-specific

CALCulate<n>:MARKer<m>:FUNCtion:HARMonics:PRESet

This command optimizes the settings for the harmonic distortion measurement.

This command is an event and therefore has no query and no *RST value.

Example

```
CALC:MARK:FUNC:HARM ON
```

Activates the harmonic distortion measurement.

```
CALC:MARK:FUNC:HARM:NHAR 4
```

Sets the number of harmonics to 4.

```
CALC:MARK:FUNC:HARM:PRESet
```

Adjusts the settings of the measurement.

```
CALC:MARK:FUNC:HARM:LIST?
```

```
CALC:MARK:FUNC:HARM:DIST? TOT
```

Queries the position of the harmonics and the total harmonic distortion.

Characteristics

*RST value: -

SCPI: device-specific

7.2.8.8 Measuring the AM Modulation Depth

The following commands configure AM Modulation Depth measurements. To perform the actual measurement, use the commands described in section "[Performing and Triggering Measurements](#)".

The numeric suffixes <n> and <m> at CALCulate and MARKer are irrelevant.

List of commands

- `CALCulate<n>:MARKer<m>:FUNCtion:MDEPth[:STATe] <State>` (p. 113)
- `CALCulate<n>:MARKer<m>:FUNCtion:MDEPth:RESult?` (p. 113)

CALCulate<n>:MARKer<m>:FUNcTion:MDEPth[:STATe] <State>

This command turns the AM Modulation Depth measurement on and off.

The numeric suffixes at CALCulate and MARKer are irrelevant.

Parameter

<State>
ON | OFF

Example

```
CALC:MARK:FUNC:MDEP ON
```

Activates the harmonic distortion measurement.

Characteristics

*RST value: OFF
SCPI: device-specific

CALCulate<n>:MARKer<m>:FUNcTion:MDEPth:RESult?

This command queries the results of the AM modulation depth measurement.

This command is a query and therefore has no *RST value.

Return value

<ModulationDepth>
Modulation depth in %.

Example

```
CALC:MARK:FUNC:MDEP:RES?
```

Queries the AM modulation depth.

Characteristics

*RST value: -
SCPI: device-specific

7.2.8.9 Measuring the Spectrum Emission Mask

The following commands configure Spectrum Emission Mask (SEM) measurements. To perform the actual measurement, use the commands described in section "[Performing and Triggering Measurements](#)".

List of commands

- [\[SENSe:\]ESpectrum:PRESet\[:STANdard\] <Standard>](#) (p. 114)
- [\[SENSe:\]ESpectrum:PRESet:SETTings](#) (p. 114)
- [\[SENSe:\]SWEep:MODE <State>](#) (p. 115)
- [CALCulate<n>:MARKer<m>:FUNcTion:TXPower:RESult?](#) (p. 114)

CALCulate<n>:MARKer<m>:FUNCtion:TXPower:RESult?

This command queries the TX channel power.

Return value

<Power>

The power is either the peak power or the channel power, depending on the selected standard.

Example

```
CALC:MARK:FUNC:TXP:RES?
```

Queries the total channel power over all TX channels.

Characteristics

*RST value: -

SCPI: device-specific

[SENSe:]ESpectrum:PRESet[:STANdard] <Standard>

This command loads one of the predefined spectrum emission masks for a telecommunications standard.

Parameter

<Standard>

String containing the file name of the spectrum emission mask.

Example

```
ESP:PREs 'W-CDMA 3GPP.semstd'
```

Loads the SEM for 3GPP WCDMA.

Characteristics

*RST value: -

SCPI: device-specific

[SENSe:]ESpectrum:PRESet:SETTings ONCE

This command optimizes the settings for the SEM measurement.

This command is an event and therefore has no query and no *RST value.

Parameter

ONCE

Example

```
ESP:PREs:SET ONCE
```

Initializes an adjustment of the settings.

Characteristics

*RST value: -

SCPI: device-specific

[SENSe:]SWEep:MODE <State>

This command turns the spectrum emission mask measurement on and off.

Parameter

AUTO	Turns on the Spectrum mode.
ESPectrum	Turns on the SEM measurement.
LIST	Turns on the Spurious Emission measurement.
SEGMented	Turns on segmented sweep.

Example

```
SWE:MODE ESP
```

Starts the SEM measurement.

Characteristics

*RST value: AUTO
SCPI: device-specific

7.2.8.10 Measuring Spurious Emissions

The following commands configure Spurious Emission measurements. To perform the actual measurement, use the commands described in section "[Performing and Triggering Measurements](#)".

List of commands

- [\[SENSe:\]FREQUENCY:CARRier:STARt <Frequency>](#) (p. 115)
- [\[SENSe:\]FREQUENCY:CARRier:STOP <Frequency>](#) (p. 116)
- [\[SENSe:\]SWEep:MODE <State>](#) (p. 115)

[SENSe:]FREQUENCY:CARRier:STARt <Frequency>

This command defines the start frequency of the 3GPP carrier.

Parameter

<Frequency>
Numeric value in Hz.

Example

```
FREQ:CARR:STAR 1910MHZ
```

Defines a carrier start frequency of 1910 MHz.

Characteristics

*RST value: -
SCPI: device-specific

[SENSe:]FREQuency:CARRier:STOP <Frequency>

This command defines the start frequency of the 3GPP carrier.

Parameter

<Frequency>
Numeric value in Hz.

Example

```
FREQ:CARR:STOP 1990MHZ
```

Defines a carrier stop frequency of 1990 MHz.

Characteristics

*RST value: -
SCPI: device-specific

7.2.8.11 Using the Segmented Sweep

This chapter describes all commands available to set up segmented sweep measurements.

The suffix <n> at CALCulate selects the trace (diagram) for segmented sweep measurements. The range is {1...2}.

List of commands

- [\[SENSe:\]SWEEp:MODE <State>](#) (p. 115)
- [CALCulate<n>:MARKer:FUNction:POWer:SEGmented:SElect <Measurement>](#) (p. 116)
- [CALCulate<n>:MARKer:FUNction:POWer:SEGmented\[:STATe\] <State>](#) (p. 117)

CALCulate<n>:MARKer:FUNction:POWer:SEGmented:SElect <Measurement>

This command selects the power measurement in the segmented sweep application. To activate the selected measurement, use [CALCulate<n>:MARKer:FUNction:POWer:SEGmented\[:STATe\] <State>](#).

Parameter

<Measurement>

CPOWer	Selects the channel power measurement.
OBANdwidth OBWidth	Selects the occupied bandwidth measurement.

Example

```
CALC2:MARK:FUNC:POW:SEGM:SEL CPOW
```

Select channel power measurement for trace 2.

Characteristics

*RST value: ---
 SCPI: device-specific

CALCulate<n>:MARKer:FUNCtion:POWer:SEGMented[:STATe] <State>

This command turns the selected power measurement in segmented sweep on and off.

Parameter

<State>

ON 1	Activates the selected power measurement.
OFF 0	Runs a basic spectrum measurement.

Example

```
CALC2:MARK:FUNC:POW:SEGM:SEL CPOW
```

```
CALC2:MARK:FUNC:POW:SEGM ON
```

Select and activate channel power measurement for trace 2.

Characteristics

*RST value: ---
 SCPI: device-specific

7.2.8.12 Using an Isotropic Antenna

This chapter describes all commands available to set up measurements with an isotropic antenna.

You can use an isotropic antenna with all measurement modes that are described above.

List of commands

- [INPut:ANTenna:MEASure <Direction>](#) (p. 117)
- [INPut:ANTenna:STATe <State>](#) (p. 118)
- [\[SENSe:\]CORRection:TRANsducer<c>:ISOTropic\[:STATe\]?](#) (p. 118)

INPut:ANTenna:MEASure <Direction>

This command selects the direction that the isotropic antenna measures.

Parameter

<Direction>

AUTO	Automatically selects the direction. In the Digital Modulation analyzer, AUTO turns the isotropic antenna off.
X Y Z	Measures the corresponding direction only.

Example

```
INP:ANT:MEAS X
Measures in x-direction.
```

Characteristics

*RST value: AUTO
SCPI: device-specific

INPut:ANTenna:STATe <State>

This command turns the use of an isotropic antenna on and off.

Parameter

```
<State>
ON | OFF
```

Example

```
INP:ANT:STAT ON
Activates the isotropic antenna
```

Characteristics

*RST value: OFF
SCPI: device-specific

[SENSe:]CORRection:TRANsducer<c>:ISOTropic[:STATe]?

This command queries if the currently selected transducer is an isotropic antenna.

When you use the command for 3GPP WCDMA measurements in the Digital Modulation operating mode, the command also turns the use of an isotropic antenna on and off.

The numeric suffix <t> at TRANsducer selects the primary or secondary transducer and is in the range <1...2>.

Return values

0	Transducer is not an isotropic antenna.
1	Transducer is an isotropic antenna.

Example

```
CORR:TRAN:ISOT?
```

Characteristics

*RST value: -
SCPI: device-specific

7.3 Remote Commands of the Network Analyzer Mode

The chapter provides information on remote commands that configure and perform two-port measurements with the tracking generator. These commands are available in network analyzer mode only.



Availability of remote commands for the Network Analyzer

Note that some of the listed remote commands take effect only if options R&S FSH-K42 Vector Reflection and Transmission Measurements and / or R&S FSH-K45 Vector Voltmeter are installed.

Contents

- [Configuring the Horizontal Axis](#) on page 119
- [Configuring the Vertical Axis](#) on page 120
- [Setting the Bandwidths](#) on page 131
- [Performing and Triggering the Measurement](#) on page 131
- [Working with Traces](#) on page 132
- [Using Markers and Deltamarkers](#) on page 134
- [Configuring the Measurement](#) on page 138

7.3.1 Configuring the Horizontal Axis

The following commands configure the horizontal axis of the active display.

The suffix <n> in the following commands is irrelevant.

List of commands

- [\[SENSe:\]FREQUency:CENTer<n> <Frequency>](#) (p. 37)
- [\[SENSe:\]FREQUency:CENTer:STEP <StepSize>](#) (p. 37)
- [\[SENSe:\]FREQUency:CENTer:STEP:LINK <StepSizeCoupling>](#) (p. 38)
- [\[SENSe:\]FREQUency:SPAN<n>](#) (p. 40)
- [\[SENSe:\]FREQUency:SPAN<n>:FULL](#) (p. 40)
- [\[SENSe:\]FREQUency:STARt<n> <StartFrequency>](#) (p. 41)
- [\[SENSe:\]FREQUency:STOP<n> <StopFrequency>](#) (p. 41)

For a detailed description of the commands refer to "[Configuring the Horizontal Axis](#)" in spectrum mode.

7.3.2 Configuring the Vertical Axis

The following commands configure the level axis (y-axis) and level parameters of the active display.

The suffix <n> at DISPLAY selects the measurement screen in dual trace mode. The range is {1...2}.

List of commands

- [DISPlay<n>:GDElay:REFerence <RefValue>](#) (p. 120)
- [DISPlay<n>:GDElay:REFerence:POSition <RefPosition>](#) (p. 121)
- [DISPlay<n>:GDElay:Y:SCALe <DisplayRange>](#) (p. 121)
- [DISPlay<n>:IMPedance:REFerence:POSition <Impedance>](#) (p. 136)
- [DISPlay<n>:LOSS:REFerence <RefValue>](#) (p. 121)
- [DISPlay<n>:LOSS:REFerence:POSition <RefPosition>](#) (p. 122)
- [DISPlay<n>:LOSS:Y:SCALe <DisplayRange>](#) (p. 122)
- [DISPlay<n>:MAGNitude:REFerence <RefValue>](#) (p. 123)
- [DISPlay<n>:MAGNitude:REFerence:POSition <RefPosition>](#) (p. 123)
- [DISPlay<n>:MAGNitude:Y:SCALe <DisplayRange>](#) (p. 123)
- [DISPlay<n>:MAGNitude:Y:SPACing <Scaling>](#) (p. 124)
- [DISPlay<n>:PHASe:REFerence <RefValue>](#) (p. 124)
- [DISPlay<n>:PHASe:REFerence:POSition <RefPosition>](#) (p. 124)
- [DISPlay<n>:PHASe:Y:SCALe <DisplayRange>](#) (p. 125)
- [DISPlay<n>:PHASe:UNWRap <State>](#) (p. 125)
- [DISPlay<n>:REFLection:Y:SCALe <DisplayRange>](#) (p. 126)
- [DISPlay<n>:REFLection:UNIT <Unit>](#) (p. 126)
- [DISPlay<n>:VSWR:Y:SCALe:MINimum <BottomValue>](#) (p. 126)
- [DISPlay<n>:VSWR:Y:SCALe:MAXimum <TopValue>](#) (p. 127)
- [DISPlay<n>:VSWR:Y:SCALe <DisplayRange>](#) (p. 127)
- [INPut<n>:ATTenuation <Attenuation>](#) (p. 44)
- [INPut<n>:ATTenuation:AUTO <State>](#) (p. 45)
- [INPut<n>:ATTenuation:MODE <AttenuationMode>](#) (p. 45)
- [INPut:IMPedance <Impedance>](#) (p. 46)
- [UNIT<n>:POWer <Unit>](#) (p. 48)

For a detailed description of commands not described below refer to "[Configuring the Vertical Axis](#)" in spectrum analyzer mode.

DISPlay<n>:GDElay:REFerence <RefValue>

This command sets the reference value for the group delay measurement format.

Parameter

<RefValue>

Numeric value in the range from 1 ns to 1000 ns.

Example

```
DISP:GDEL:REF 20
```

Sets the reference level to 20 nanoseconds

Characteristics

*RST value: 0 ns
SCPI: device-specific

DISPlay<n>:GDElay:REFerence:POSition <RefPosition>

This command defines the position of the reference value on the display for the group delay measurement format.

Each step shifts the reference position one grid line up or down.

Parameter

<RefPosition>
Numeric value in the range from 0 to 10.

Example

```
DISP:GDEL:REF:POS 1
```

Sets the reference to the first grid line from the bottom.

Characteristics

*RST value: 5
SCPI: device-specific

DISPlay<n>:GDElay:Y:SCALE <DisplayRange>

This command defines the display range of the vertical axis for the group delay measurement format.

Parameter

<DisplayRange>
Numeric value in the range from 10 ns to 100000 ns.

The number you enter is rounded up to the next possible display range. For example, if you enter 9, the R&S FSH automatically sets the display range to 10.

Example

```
DISP:GDEL:Y:SCAL 20E-9
```

Sets the display range to 20 nanoseconds

Characteristics

*RST value: 100 ns
SCPI: device-specific

DISPlay<n>:LOSS:REFerence <RefValue>

This command sets the reference value for the cable loss measurement format.

Parameter

<RefValue>
Numeric value in the range from -100 dB to 100 dB.

Example

```
DISP:LOSS:REF 10
```

Sets the reference level to 10 dB

Characteristics

*RST value: 0 dB
SCPI: device-specific

DISPlay<n>:LOSS:REFerence:POSition <RefPosition>

This command defines the position of the reference value on the display for the cable loss measurement format.

Each step shifts the reference position one grid line up or down.

Parameter

<RefPosition>
Numeric value in the range from 0 to 10.

Example

```
DISP:LOSS:REF:POS 5
```

Sets the reference to the center of the display (i.e. the fifth grid line from the bottom).

Characteristics

*RST value: 10
SCPI: device-specific

DISPlay<n>:LOSS:Y:SCALe <DisplayRange>

This command defines the display range of the vertical axis for the cable loss measurement format.

Parameter

<DisplayRange>
Numeric value in the range from 1 dB to 100 dB.

The number you enter is rounded up to the next possible display range. For example, if you enter 9, the R&S FSH automatically sets the display range to 10.

Example

```
DISP:LOSS:Y:SCAL 20
```

Sets the display range to 20 dB

Characteristics

*RST value: 100 dB
SCPI: device-specific

DISPlay<n>:MAGNitude:REFerence <RefValue>

This command sets the reference value for the magnitude measurement format.

Parameter

<RefValue>

Numeric value in the range from -80 dB to 30 dB.

Example

```
DISP:MAGN:REF -10
```

Sets the reference level to -10 dB

Characteristics

*RST value: 0 dB

SCPI: device-specific

DISPlay<n>:MAGNitude:REFerence:POSition <RefPosition>

This command defines the position of the reference value on the display for the magnitude measurement format.

Each step shifts the reference position one grid line up or down.

Parameter

<RefPosition>

Numeric value in the range from 0 to 10.

Example

```
DISP:MAGN:REF:POS 5
```

Sets the reference to the center of the display (i.e. the fifth grid line from the bottom).

Characteristics

*RST value: 10

SCPI: device-specific

DISPlay<n>:MAGNitude:Y:SCALE <DisplayRange>

This command defines the display range of the vertical axis for the magnitude measurement format.

Note that you have to set a logarithmic scaling before you can use this command with `DISPlay<n>:MAGNitude:Y:SPACing <Scaling>`.

Parameter

<DisplayRange>

Numeric value in the range from 1 dB to 150 dB.

The number you enter is rounded up to the next possible display range. For example, if you enter 9, the R&S FSH automatically sets the display range to 10.

Example

```
DISP:MAGN:Y:SCAL 50 DB
```

Sets the display range of the y-axis to 50 dB

Characteristics

*RST value: 100 dB
 SCPI: device-specific

DISPlay<n>:MAGNitude:Y:SPACing <Scaling>

This command selects the scaling of the vertical axis for the magnitude measurement format.

Parameter

<Scaling>

LOGarithmic	Selects a logarithmic scale (in dB).
LINear	Selects a linear scale (in %).

Example

```
DISP:MAGN:Y:SPAC LIN
```

Switches the y-axis to linear scaling

Characteristics

*RST value: LOGarithmic
 SCPI: device-specific

DISPlay<n>:PHASe:REFerence <RefValue>

This command sets the reference value for the phase measurement format.

Parameter

<RefValue>

Numeric value in the range from -100000° to 100000°.

Example

```
DISP:MAGN:REF -10
```

Sets the reference level to -10 dB

Characteristics

*RST value: 0 dB
 SCPI: device-specific

DISPlay<n>:PHASe:REFerence:POSition <RefPosition>

This command defines the position of the reference value on the display for the phase measurement format.

Each step shifts the reference position one grid line up or down.

Parameter

<RefPosition>

Numeric value in the range from 0 to 10.

Example

DISP:LOSS:REF:POS 5

Sets the reference to the center of the display (i.e. the fifth grid line from the bottom).

Characteristics

*RST value: 10

SCPI: device-specific

DISPlay<n>:PHASe:Y:SCALe <DisplayRange>

This command defines the display range of the vertical axis for the phase measurement format.

Parameter

<DisplayRange>

Numeric value in the range from 90° to 100000°.

The number you enter is rounded up to the next possible display range. For example, if you enter 80°, the R&S FSH automatically sets the display range to 90°.

Example

DISP:PHAS:Y:SCAL 180

Sets the display range of the phase measurement to 180°

Characteristics

*RST value: 360°

SCPI: device-specific

DISPlay<n>:PHASe:UNWRap <State>

This command removes the restriction limiting the value range to +/- 180°.

Parameter

<State>

ON | OFF

Example

DISP:PHAS:UNWR ON

Activates the phase unwrap

Characteristics

*RST value: OFF

SCPI: device-specific

DISPlay<n>:REFlection:Y:SCALe <DisplayRange>

This command defines the display range of the vertical axis for the reflection coefficient measurement format.

Parameter

<DisplayRange>

Numeric value in the range from 1 dB to 1000 mrho.

The number you enter is rounded up to the next possible display range. For example, if you enter 18, the R&S FSH automatically sets the display range to 20 mrho.

Example

```
DISP:REFL:Y:SCAL 100
```

Sets a display range of 100 mrho.

Characteristics

*RST value: 1000 mp

SCPI: device-specific

DISPlay<n>:REFlection:UNIT <Unit>

This command defines the unit of the reflection coefficient.

Parameter

<Unit>

RHO | MRHO

Example

```
DISP:REFL:UNIT RHO
```

Sets the unit to RHO.

Characteristics

*RST value: MRHO

SCPI: device-specific

DISPlay<n>:VSWR:Y:SCALe:MINimum <BottomValue>

This command defines the bottom value of the vertical axis for the VSWR measurement format.

Parameter

<BottomValue>

Numeric value in the range from 1.0 to 70.

Example

```
DISP:VSWR:Y:SCAL:MIN 3
```

Defines a bottom value of 3 for the vertical axis.

Characteristics

*RST value: 1.0
SCPI: device-specific

DISPlay<n>:VSWR:Y:SCALE:MAXimum <TopValue>

This command defines the top value of the vertical axis for the VSWR measurement format.

Parameter

<TopValue>
Numeric value in the range from 1.1 to 71.

Example

```
DISP:VSWR:Y:SCALE:MAX 25
```

Defines a top value of 25 for the vertical axis.

Characteristics

*RST value: 21
SCPI: device-specific

DISPlay<n>:VSWR:Y:SCALE <DisplayRange>

This command defines the display range of the vertical axis for the VSWR measurement format.

Parameter

<DisplayRange>
Numeric value in the range from 1.1 to 71.

The number you enter is rounded up to the next possible display range. For example, if you enter 5, the R&S FSH automatically sets the display range to 1...6.

Example

```
DISP:VSWR:Y:SCALE 50
```

Sets the range to 1...71.

Characteristics

*RST value: 1...21
SCPI: device-specific

7.3.3 Configuring the Tracking Generator

The following commands configure the characteristics of the tracking generator of the R&S FSH.

List of commands

- [SOURce:TG:ATTenuation <Attenuation>](#) (p. 128)
- [SOURce:TG:AUTO <State>](#) (p. 128)
- [SOURce:TG:FREQuency <Frequency>](#) (p. 129)
- [SOURce:TG:OFFSet <Level>](#) (p. 129)
- [SOURce:TG:POWer <Level>](#) (p. 129)
- [SOURce:TG\[:STATe\] <State>](#) (p. 130)

SOURce:TG:ATTenuation <Attenuation>

This command defines the relative output level of the tracking generator.

Parameter

<TGAttenuation>

Numeric value in the range from 0 to 40 dB.

An attenuation of, for example, 20 dB results in an output level of -20 dBm.

Example

```
SOUR:TG:ATT 40
```

Sets the attenuation to 40 dB and therefore an output level of -40 dBm

Characteristics

*RST value: 0 dB

SCPI: device-specific

SOURce:TG:AUTO <State>

This command turns the generation of a CW signal in zero span on and off.

In case of zero span, you can define a fixed frequency for the generated signal ([SOURce:TG:FREQuency <Frequency>](#)) and turn the tracking generator on and off ([SOURce:TG\[:STATe\] <State>](#)).

Parameter

<State>

ON | OFF

Example

```
SOUR:TG:AUTO ON
```

Selects zero span measurement mode.

Characteristics

*RST value: OFF

SCPI: device-specific

SOURce:TG:FREQuency <Frequency>

This command defines the frequency of the generated signal.

Available when zero span has been turned on, for example with

[SOURce:TG:AUTO <State>..](#)

Parameter

<Frequency>

Numeric value in Hz.

Example

```
SOUR:TG:AUTO ON
SOUR:TG:FREQ 500MHZ
SOUR:TG:POW -10
```

Generates a CW signal with 500 MHz and a power of -10 dBm in zero span.

Characteristics

*RST value: OFF

SCPI: device-specific

SOURce:TG:OFFSet <Level>

This command defines a mathematical level offset for the tracking generator, for example to take external attenuation into account.

The level offset has no effect on the actual level of the signal that is generated.

Parameter

<Level>

Numeric value in the range from -200 dB to 200 dB.

Example

```
SOUR:TG:OFFS 50
Defines an offset of 50 dB.
```

Characteristics

*RST value: 0 dB

SCPI: device-specific

SOURce:TG:POWer <Level>

This command defines the absolute output level of the tracking generator.

Parameter

<Level>

Numeric value in the range from 0 to -40 dBm.

Example

```
SOUR:TG:POW -20
Defines an output level of -20 dBm.
```

Characteristics

*RST value: 0 dBm
SCPI: device-specific

SOURce:TG[:STATe] <State>

This command turns the tracking generator on and off.

Available when zero span has been turned on, for example with [SOURce:TG:AUTO <State>](#).

Parameter

<State>
ON | OFF

Example

```
SOUR:TG:AUTO ON  
SOUR:TG OFF
```

Stops the generation of a CW signal.

Characteristics

*RST value: OFF
SCPI: device-specific

7.3.4 Setting the Bandwidths

The following commands configure the filter bandwidths of the R&S FSH. Note that both groups of commands (BANDwidth and BWIDth) are the same.

List of commands

- [\[SENSe:\]BANDwidth|BWIDth<n>\[:RESolution\] <ResBW>](#) (p. 49)
- [\[SENSe:\]BANDwidth|BWIDth<n>\[:RESolution\]:AUTO <State>](#) (p. 49)

For a detailed description of commands refer to "[Setting the Bandwidths](#)" in spectrum analyzer mode.

7.3.5 Performing and Triggering the Measurement

The following commands configure the sweep.

The suffix <n> in the following commands is irrelevant.

List of commands

- [*WAI](#) (p. 35)
- [ABORt](#) (p. 51)
- [INITiate\[:IMMediate\]](#) (p. 51)
- [INITiate:CONTInuous <SweepMode>](#) (p. 52)
- [\[SENSe:\]SWEep:COUNt<n> <SweepCount>](#) (p. 52)
- [\[SENSe:\]SWEep:POINts?](#) (p. 53)
- [\[SENSe:\]SWEep:TIME<n> <SweepTime>](#) (p. 53)
- [\[SENSe:\]SWEep:TIME<n>:AUTO <State>](#) (p. 53)
- [TRIGger<n>\[:SEQuence\]:HOLDoff\[:TIME\] <TriggerDelay>](#) (p. 58)
- [TRIGger<n>\[:SEQuence\]:SLOPe <TriggerSlope>](#) (p. 58)
- [TRIGger<n>\[:SEQuence\]:SOURce <TriggerSource>](#) (p. 59)

For a detailed description of commands refer to "[Performing and Triggering Measurements](#)" in spectrum analyzer mode.

7.3.6 Working with Traces

The following commands set up the trace and the various functions associated with it, e.g. the selection of the detector.

The suffix <n> in the following commands selects the measurement screen in dual trace mode and is in the range {1...2}.

List of commands

- [DISPlay\[:WINDow\]:TRACe<n>:MEMory\[:STATe\] <State>](#) (p. 61)
- [DISPlay\[:WINDow\]:TRACe<n>:MODE <TraceMode>](#) (p. 62)
- [FORMat\[:DATA\] <DataFormat>](#) (p. 65)
- [FORMat:BORDER <ByteOrder>](#) (p. 62)
- [\[SENSe:\]DETEctor<n>\[:FUNCTion\] <Detector>](#) (p. 63)
- [\[SENSe:\]DETEctor<n>\[:FUNCTion\]:AUTO <State>](#) (p. 63)
- [TRACe\[:DATA\]?](#) (p. 132)
- [TRACe<n>:DATA:MEMory? <Trace>](#) (p. 64)

For a detailed description of commands not described here refer to "[Working with Traces](#)" in spectrum analyzer mode.

TRACe[:DATA]?

This command reads out the trace data of the current measurement.

With the [FORMat\[:DATA\] <DataFormat>](#) command, you can set the data format.

Parameter

The available parameters depend on the format of the result display.

Display of one S-parameter

TRACE1	Queries the data of the currently displayed trace.
--------	--

Display of two S-parameters (split screen mode)

TRACE1	Queries the data displayed in the upper screen.
TRACE2	Queries the data displayed in the lower screen.

Display of four S-parameters (split screen mode)

TRACE1	Queries the data of S11.
TRACE2	Queries the data of S21.
TRACE3	Queries the data of S22.
TRACE4	Queries the data of S12.

Return value

The R&S FSH returns 631 values. Each value corresponds to one pixel of a trace.

The result and unit depends on the measurement format.

Note that for the MPHase format (simultaneous measurement of magnitude and phase), you can read out the magnitude data with the parameter `TRACE1` and the phase data with the parameter `TRACE2`.

Example

```
TRAC:DATA? TRACE1
```

Reads out the data for trace 1.

Characteristics

*RST value: -

SCPI: conform

7.3.7 Using Markers and Deltamarkers

7.3.7.1 Markers and Deltamarkers

The following commands are for setting and controlling markers and deltamarkers.

The suffix <n> at CALCulate selects the measurement screen in dual trace mode and is in the range {1...2}.

The suffix <m> at MARKer selects the marker and is in the range {1...6}.

List of commands

- CALCulate<n>:DELTamarker<m>[:STATe] <State> (p. 66)
- CALCulate<n>:DELTamarker<m>:AOFF (p. 67)
- CALCulate<n>:DELTamarker<m>:MAXimum[:PEAK] (p. 67)
- CALCulate<n>:DELTamarker<m>:MAXimum:NEXT (p. 67)
- CALCulate<n>:DELTamarker<m>:MINimum[:PEAK] (p. 68)
- CALCulate<n>:DELTamarker<m>:X <Coordinate> (p. 68)
- CALCulate<n>:DELTamarker<m>:X:RELative <Distance> (p. 69)
- CALCulate<n>:DELTamarker<m>:Y? (p. 69)
- CALCulate<n>:MARKer<m>[:STATe] <State> (p. 70)
- CALCulate<n>:MARKer<m>:AOFF (p. 70)
- CALCulate<n>:MARKer<m>:MAXimum[:PEAK] (p. 70)
- CALCulate<n>:MARKer<m>:MAXimum:NEXT (p. 71)
- CALCulate<n>:MARKer<m>:MINimum[:PEAK] (p. 71)
- CALCulate<n>:MARKer<m>:MODE <MarkerMode> (p. 134)
- CALCulate<n>:MARKer<m>:X <Coordinate> (p. 71)
- CALCulate<n>:MARKer<m>:X:SLIMits[:STATe] <State> (p. 72)
- CALCulate<n>:MARKer<m>:X:SLIMits:LEFT <SearchLimit> (p. 72)
- CALCulate<n>:MARKer<m>:X:SLIMits:RIGHT <Searchlimit> (p. 73)
- CALCulate<n>:MARKer<m>:Y? (p. 135)

For a detailed description of commands not described below refer to "[Using Markers](#)" in spectrum analyzer mode.

CALCulate<n>:MARKer<m>:MODE <MarkerMode>

This command selects the type of information a marker shows.

Parameter

ADMittance	admittance in complex format (real + imaginary)
IMPedance	impedance in complex format (real + imaginary)
NADMittance	standardized admittance in complex format (real + imaginary)
NIMPedance	standardized impedance in complex format (real + imaginary)
NORMal	normal marker
RPDB	reflection coefficient in complex format (magnitude (dB) + phase)
RPL	reflection coefficient in complex format (magnitude (lin) + phase)
RSCalar	reflection coefficient in complex format (real + imaginary)

Example

```
CALC:MARK:MODE ADM
```

Selects admittance in complex format with real and imaginary components

Characteristics

*RST value: NORMAl

SCPI: device-specific

CALCulate<n>:MARKer<m>:Y?

This command queries the measurement results at the marker position.

If necessary, the corresponding marker is activated first.

To get a valid result, you have to perform a complete sweep with synchronization to the sweep end between activating the delta marker and reading out the result. This is only possible in single sweep mode.

Return value

The return value depends on the marker format you have selected with [CALCulate<n>:MARKer<m>:MODE](#).

ADMittance	<real part>, <imaginary part>
IMPedance	<real part>, <imaginary part>
NADMittance	<real part>, <imaginary part>
NIMPedance	<real part>, <imaginary part>
NORMAl	<value> = trace value
RPDB	<magnitude in dB>, <phase>
RPL	<magnitude linear>, <phase>
RSCalar	<real part>, <imaginary part>

Example

```
INIT:CONT OFF
```

```
CALC:MARK2 ON
```

Turns on single sweep mode and marker 2.

```
INIT;*WAI
```

```
CALC:MARK2:Y?
```

Performs a measurement and queries the marker position.

Characteristics

*RST value: –

SCPI: device-specific

7.3.7.2 Marker Functions

The following commands perform various kinds of analysis at the marker position.

The suffix <n> at DISPlay selects the measurement screen in dual trace mode and is in the range <1...2>.

List of commands

- [DISPlay<n>:IMPedance:REFerence:POSition <Impedance>](#) (p. 136)
- [DISPlay<n>:ZOOM:AREA\[:STAT\] <State>](#) (p. 136)
- [DISPlay<n>:ZOOM:FACTor <ZoomFactor>](#) (p. 137)
- [DISPlay<n>:ZOOM:X <HorizShift>](#) (p. 137)
- [DISPlay<n>:ZOOM:Y <VerticalShift>](#) (p. 137)

DISPlay<n>:IMPedance:REFerence:POSition <Impedance>

This command sets the reference impedance for the smith chart measurement format. The impedance can be between 1mΩ and 10 kΩ.

Parameter

<Impedance>

Numeric value in the range from 1 mΩ to 10 kΩ.

Example

```
DISP:IMP:REF:POS 75 OHM
```

Sets the reference impedance to 75 Ohm.

Characteristics

*RST value: 50

SCPI: device-specific

DISPlay<n>:ZOOM:AREA[:STAT] <State>

This command turns the marker zoom function in a Smith chart on and off.

Parameter

<State>

ON | OFF

Example

```
DISP:ZOOM:AREA ON
```

Activates the marker zoom function.

Characteristics

*RST value: OFF

SCPI: device-specific

DISPlay<n>:ZOOM:FACTOR <ZoomFactor>

This command sets the zoom factor of the marker zoom function in a Smith chart.

Parameter

<ZoomFactor>

2 | 4 | 8

Example

```
DISP:ZOOM:FACT 4
```

Sets the zoom factor to 4

Characteristics

*RST value: -

SCPI: device-specific

DISPlay<n>:ZOOM:X <HorizShift>

This command shifts the zoom window horizontally in the Smith chart.

'0%' marks the center on the horizontal axis.

Parameter

<HorizShift>

Numeric value in the range from -50 % to 50 %.

Example

```
DISP:ZOOM:X 10
```

Shift the zoom window 10% to the right.

Characteristics

*RST value: 0

SCPI: device-specific

DISPlay<n>:ZOOM:Y <VerticalShift>

This command shifts the zoom window vertically in the Smith chart.

'0%' marks the center on the vertical axis.

Parameter

<VerticalShift>

Numeric value in the range from -50 % to 50 %.

Example

```
DISP:ZOOM:Y -25
```

Shifts the zoom window 25% down.

Characteristics

*RST value: 0

SCPI: device-specific

7.3.8 Configuring the Measurement

This chapter provides information on how to configure two-port measurements with the tracking generator. The structure follows the order of the actual operation sequence used when performing a measurement:

The suffix <n> at MEASurement selects the measurement screen in dual trace mode and is in the range from {1...2}.

- [Selecting the Measurement Port](#) on page 138
- [Selecting the Measurement Mode](#) on page 139
- [Calibrating the Measurement](#) on page 139
- [Selecting the Result Display](#) on page 141
- [Selecting the Measurement Format](#) on page 142

It also deals with configuring the Vector Voltmeter (Option R&S FSH-K45).

- [Configuring the Vector Voltmeter \(option R&S FSH-K45\)](#) on page 145

To perform the actual measurement, use the commands described in section "[Performing and Triggering the Measurement](#)".



Commands independent of the operating mode

Note that some of the commands for configuring two-port measurements are also valid for other operating modes. If a command is available in another mode, it is indicated by the list in the respective section.

7.3.8.1 Selecting the Measurement Port

The following commands select the measurement port.

List of commands

- [MEASurement:PORT <Port>](#) (p. 138)

MEASurement:PORT <Port>

This command selects the measurement port.

Parameter

<Port>

Numeric value in the range from 1 to 2.

Example

```
MEAS:PORT 1
Selects port 1.
```

Characteristics

*RST value: 1

SCPI: device-specific

7.3.8.2 Selecting the Measurement Mode

The following commands select the measurement mode for two-port measurements.

List of commands

- [MEASurement<n>:MODE <MeasMode>](#) (p. 139)

MEASurement<n>:MODE <MeasMode>

This command sets the measurement mode for network analysis measurements.

Parameter

<MeasMode>

SCALar	Scalar measurements.
VECTor	Vector measurements.
VVMeter	Vector Voltmeter.

Example

```
MEAS:MODE SCAL
Starts a scalar measurement.
```

Characteristics

*RST value: VECTor
SCPI: device-specific

7.3.8.3 Calibrating the Measurement

The following commands query and control calibration for two-port measurements.

List of commands

- [CALCulate:CALKit:USER\[:STATe\]](#) (p. 139)
- [CALCulate:CALKit:USER:LENGth <ElecLength>](#) (p. 140)
- [CALCulate:CALKit:USER:OFFSet<p>:LENGth <ElecLengthOffs>](#) (p. 140)
- [CALibration:MODE?](#) (p. 141)
- [CALibration:STATus?](#) (p. 141)

The suffix <p> selects the measurement port. It is in the range <1...2>.

CALCulate:CALKit:USER[:STATe]

This command turns user calibration on and off.

Parameter

<State>
ON | OFF

Example

```
CALK:USER ON
```

Activates the calibration standard.

Characteristics

*RST value: OFF
SCPI: device-specific

CALCulate:CALKit:USER:LENGth <ElecLength>

This command sets the electrical length of the user calibration.

The electrical length is taken into account for phase measurements and the Smith chart.

Parameter

<ElecLength>
Numeric value in the range from 0 mm to 1 m.

Example

```
CALK:USER:LENG 5 MM
```

Sets the electrical length to 5 millimeter

Characteristics

*RST value: 5.27 mm
SCPI: device-specific

CALCulate:CALKit:USER:OFFSet<p>:LENGth <ElecLengthOffs>

This command sets the offset of the electrical length. It is taken into account for phase measurements and in the Smith Chart when phase correction for additional cables and adapters has to be performed.

The offset is taken into account for phase measurements and the Smith chart if you perform phase correction for additional cables and adapters.

Parameter

<ElecLengthOffset>
Numeric value in the range from 0 mm to 100 m.

Example

```
CALK:USER:OFFS2:LENG 500 MM
```

Sets the offset length of port 2 to 500 millimeter.

Characteristics

*RST value: 0 mm
SCPI: device-specific

CALibration:MODE?

This command queries if the current measurement is calibrated.

This command is a query and therefore has no *RST value.

Return value

0	R&S FSH is not calibrated.
1	R&S FSH is calibrated.

Example

CAL:MODE?

Queries the calibration state.

Characteristics

*RST value: -

SCPI: device-specific

CALibration:STATus?

This command queries if the R&S FSH is fully calibrated for the current measurement.

This command is a query and therefore has no *RST value.

Return value

NORMALized	Full factory calibration or user calibration.
APPRoximated	Approximate calibration: measurement uncertainty must be anticipated.

Example

CAL:STAT?

Queries the calibration status of the R&S FSH.

Characteristics

*RST value: -

SCPI: device-specific

7.3.8.4 Selecting the Result Display

The following commands select the result display for two-port measurements.

List of commands

- [MEASurement<n>:FUNCtion:SElect <ResultDisplay>](#) (p. 142)

MEASurement<n>:FUNCTION:SElect <ResultDisplay>

This command selects the result display.

Parameter

<ResultDisplay>
S11 | S12 | S21 | S22

Example

```
MEAS:FUNC:SEL S11
```

Characteristics

*RST value: S11
SCPI: device-specific

7.3.8.5 Selecting the Measurement Format

The following commands are for selecting and configuring the measurement formats available for two-port measurements.

List of commands

- [CALCulate:TRACe:CABLe:LENGth\[:STATe\] <State>](#) (p. 142)
- [CALCulate:TRACe:CABLe:LENGth:RESult?](#) (p. 143)
- [CALCulate:TRACe:CABLe:TIME\[:STATe\] <State>](#) (p. 143)
- [CALCulate:TRACe:CABLe:TIME:RESult?](#) (p. 143)
- [CALCulate:TRACe:LIMit:VSWR:FAIL?](#) (p. 144)
- [DISPlay:GDELay:APERture:STEP <Aperture>](#) (p. 144)
- [MEASurement<n>:FORMat <MeasFormat>](#) (p. 144)

CALCulate:TRACe:CABLe:LENGth[:STATe] <State>

This command turns the electrical length format on and off.

Parameter

<State>
ON | OFF

Example

```
CALC:TRAC:CABL:LENG ON
```

Activates the electrical cable length.

Characteristics

*RST value: OFF
SCPI: device-specific

CALCulate:TRACe:CABLE:LENGth:RESult?

This command queries the results of the electrical cable length.

This command is a query and therefore has no *RST value.

Return value

<EILength>
Numerical value in mm

Example

```
CALC:TRAC:CABL:LENG:RES?
```

Queries the measurement result of the electrical cable length.

Characteristics

*RST value: -
SCPI: device-specific

CALCulate:TRACe:CABLE:TIME[:STATe] <State>

This command turns the delay time format on and off.

Parameter

<State>
ON | OFF

Example

```
CALC:TRAC:CABL:TIME ON
```

Activates the cable delay time.

Characteristics

*RST value: OFF
SCPI: device-specific

CALCulate:TRACe:CABLE:TIME:RESult?

This command queries the results of the cable delay time.

This command is a query and therefore has no *RST value.

Return value

<DelayTime>
Numerical value in s.

Example

```
CALC:TRAC:CABL:TIME:RES?
```

Queries the measurement result of the delay time.

Characteristics

*RST value: -
SCPI: device-specific

CALCulate:TRACe:LIMit:VSWR:FAIL?

This command queries the results of the limit check for the VSWR measurement format.

This command is a query and therefore has no *RST value.

Return value

0	Limit check failed.
1	Limit check passed.

Example

`CALC:TRAC:LIM:VSWR:FAIL?`
Queries the results of the limit check.

Characteristics

*RST value: -
SCPI: device-specific

DISPlay:GDElay:APERture:STEP <Aperture>

This command sets the aperture steps for the group delay measurement format.

Parameter

<Aperture>
Numeric value in the range from 1 to 630.

Example

`DISP:GDEL:APER:STEP 100`
Defines an aperture size of 100w.

Characteristics

*RST value: 10
SCPI: device-specific

MEASurement<n>:FORMat <MeasFormat>

This command selects the measurement format.

Note:

For transmission measurements only the Magnitude, Phase, Magnitude+Phase and GDelay formats are available.

Parameter

GDElay	Group delay format.
LOSS	Cable loss format.
MAGNitude	Magnitude format.

MPHase	Simultaneous display of magnitude and phase formats.
PHASe	Phase format.
REFLection	Refelction coefficient format.
SMITH	Smith chart format.
VSWR	VSWR format.
VVMeter	Vector voltmeter format (Vector Voltmeter measurements only).

Example

MEAS:MODE VECT
Switches to vector measurement mode.

MEAS:FUNC:REFL ON
Activates reflection measurement.

MEAS:FORM SMITH
Displays the reflection in a Smith Chart.

Characteristics

*RST value: MAGNitude
SCPI: device-specific

7.3.8.6 Configuring the Vector Voltmeter (option R&S FSH-K45)

The following commands configure the vector voltmeter.



Availability of remote commands for the Vector Voltmeter

Note that the listed remote commands take effect only if option R&S FSH-K45 Vector Voltmeter is installed.

List of commands

- [CALCulate:VVMeter:MAGNitude:REFerence?](#) (p. 145)
- [CALCulate:VVMeter:MAGNitude:RESult?](#) (p. 146)
- [CALCulate:VVMeter:PHASe:REFerence?](#) (p. 146)
- [CALCulate:VVMeter:PHASe:RESult?](#) (p. 147)
- [CALCulate:VVMeter:REFerence\[:STATe\] <State>](#) (p. 147)

CALCulate:VVMeter:MAGNitude:REFerence?

This command queries the reference value for the magnitude.

To get a result, you first have to turn on the reference value with [CALCulate:VVMeter:REFerence\[:STATe\] <State>](#).

This command is a query and therefore has no *RST value.

Return value

<ReferenceValue>

Reference value for the magnitude in dB.

Example

```
CALC : VVM : PHAS : REF ?
```

Queries the reference values for the phase.

Characteristics

*RST value: -

SCPI: device-specific

CALCulate:VVMeter:MAGNitude:RESult?

This command queries the magnitude of the measurement results.

This command is a query and therefore has no *RST value.

Return values:

<Magnitude>

Magnitude of the return loss in dB.

Example

```
CALC : VVM : MAGN : RES ?
```

Queries the current return loss of the DUT

Characteristics

*RST value: -

SCPI: device-specific

CALCulate:VVMeter:PHASe:REFerence?

This command queries the reference value for the phase of the DUT.

To get a result, you first have to turn on the reference value with [CALCulate:VVMeter:REFerence\[:STATe\] <State>](#).

This command is a query and therefore has no *RST value.

Return values

<ReferenceValue>

Reference value for the phase in degrees.

Example

```
CALC : VVM : PHAS : REF ?
```

Characteristics

*RST value: -

SCPI: device-specific

CALCulate:VVMeter:PHASe:RESult?

This command queries the phase of the measurement results.

This command is a query and therefore has no *RST value.

Return values

<Phase>

Phase of the return loss in degrees.

Example

```
CALC:VVM:PHAS:RES?
```

Queries the current phase of the DUT

Characteristics

*RST value: -

SCPI: device-specific

CALCulate:VVMeter:REFerence[:STATe] <State>

This command saves the current measurement values as reference values. The reference values can be used for comparison measurements.

Parameter

<State>

ON | OFF

Example

```
CALC:VVM:REF ON
```

Activates the reference values.

Characteristics

*RST value: OFF

SCPI: device-specific

7.4 Remote Commands of the Power Meter

The chapter provides information on remote commands that configure and perform power measurements with the power sensor. These commands are available in power meter mode only.



Availability of remote commands for Power Sensor measurements

Note that the listed remote commands take effect only if a power sensor is connected.

7.4.1 Using Power Sensors

Contents

[Setting the Frequency](#) on page 148

[Configuring Power Level Readout](#) on page 149

[Defining the Measurement Time](#) on page 151

7.4.1.1 Setting the Frequency

The following chapter describes commands necessary to define frequency settings.

List of commands

- [\[SENSe:\]PMETer:FREQuency <Frequency>](#) (p. 148)
- [CALCulate:PMETer:CPOWer:BANDwidth <Bandwidth>](#) (p. 149)

[SENSe:]PMETer:FREQuency <Frequency>

This command sets the frequency of the power sensor.

Parameter

<Frequency>

Numeric value in Hz.

The available value range is specified in the data sheet.

Example

```
PMET:FREQ 500 MHZ
```

Sets the power sensor's frequency to 500 MHz

Characteristics

*RST value: -

SCPI: device-specific

CALCulate:PMETer:CPOWer:BANDwidth <Bandwidth>

This command defines the channel bandwidth.

Available for the channel power meter.

Parameter

<Bandwidth>

Numeric value in Hz.

Example

```
CALC:PMET:CPOW:BAND 5 MHZ
```

Sets the channel bandwidth to 5 MHz

Characteristics

*RST value: -
SCPI: device-specific

7.4.1.2 Configuring Power Level Readout

The following chapter describes commands that configure the power level readout.

List of commands

- [CALCulate:PMETer:RELative\[:MAGNitude\] <RefValue>](#) (p. 149)
- [CALCulate:PMETer:RELative\[:MAGNitude\]:AUTO](#) (p. 149)
- [CALCulate:PMETer:RELative\[:MAGNitude\]:OFFSet <Offset>](#) (p. 150)
- [UNIT<z>:PMETer:POWer <Unit>](#) (p. 150)

CALCulate:PMETer:RELative[:MAGNitude] <RefValue>

This command sets the reference value for relative measurements.

Parameter

<RefValue>

Numeric value in dBm.

Example

```
CALC:PMET:REL 30
```

The the reference value to 30 dBm.

Characteristics

*RST value: -
SCPI: device-specific

CALCulate:PMETer:RELative[:MAGNitude]:AUTO ONCE

This command sets the current measurement result as the reference level for relative measurements.

This command is an event and therefore has no *RST value and no query.

Parameter

ONCE

Example

CALC:PMET:REL ONCE

Adjusts the reference level to the measurement result.

Characteristics

*RST value: -

SCPI: device-specific

CALCulate:PMETer:RELative[:MAGNitude]:OFFSet <Offset>

 This command sets an offset for the reference value.
Parameter

<Offset>

Numeric value in dB.

Example

CALC:PMET:REL:OFFS -10

Defines an offset of -10 dB.

Characteristics

*RST value: -

SCPI: device-specific

UNIT<z>:PMETer:POWER <Unit>

 This command selects the unit of the power sensor.

The suffix <z>at UNIT has the following effects:

Power Measurement with R&S FSH-Z1, R&S FSH-Z18 and USB power sensors:

Unit 1	Power unit.
Unit 2	Not available.

Power Measurement with R&S FSH-Z14 and R&S FSH-Z44:

Unit 1	Forward power.
Unit 2	Reflected power.

Parameter

<Unit>

DBM | WATT | W | DB | VSWR

Note on the parameter DB: when applied to UNIT1, the power is relative to the reference level, when applied to UNIT2, the return loss is displayed.

Note on the parameter VSWR: the parameter is only available if applied to UNIT2.

Example

```
UNIT1:PMET:POW DBM
```

When measuring with the R&S FSH-Z1, R&S FSH-Z18 or USB power sensors: sets unit to dBm.

When measuring with the R&S FSH-Z14 or R&S FSH-Z44: sets unit of forward power to dBm.

Characteristics

*RST value: -

SCPI: device-specific

7.4.1.3 Defining the Measurement Time

The following chapter describes commands to define the measurement time of the power sensor.

- [\[SENSe:\]PMETer:MTIME <MeasTime>](#) (p. 151)

[SENSe:]PMETer:MTIME <MeasTime>

This command sets the duration of measurements.

Available for measurements with a power sensor.

Parameter

<MeasTime>

SHORt | NORMal | LONG

Example

```
PMET:MTIME SHOR
```

Sets a short measurement time for power measurements.

Characteristics

*RST value: -

SCPI: device-specific

7.4.1.4 Zeroing of the Power Sensor

List of commands

- [CALibration:PMETer:ZERO:AUTO](#) (p. 152)

CALibration:PMETer:ZERO:AUTO ONCE

This commands starts to zero the power sensor.

This command is an event and therefore has no *RST value and no query.

Parameter

ONCE

Example

```
CAL:PMET:ZERO:AUTO ONCE
Starts to zero the power meter.
```

Characteristics

*RST value: -
SCPI: device-specific

7.4.1.5 Forward Power Display

Note that the forward power is only available in conjunction with the R&S FSH-Z14 or R&S FSH-Z44.

List of commands

- [\[SENSe:\]PMETer:DETEctor\[:FUNCTion\] <PowerDisplay>](#) (p. 152)

[SENSe:]PMETer:DETEctor[:FUNCTion] <PowerDisplay>

This command selects the forward power display of the power sensor.

Parameter

<PowerDisplay>

AVERage	Displays the average power.
PENvelope	Displays the peak envelope power.

Example

```
PMET:DET AVER
Selects the Average weighting mode.
```

Characteristics

*RST value: -
SCPI: device-specific

7.4.1.6 Defining the Video Bandwidth

Selecting a video bandwidth is only possible when you are measuring the peak envelope power with the R&S FSH-Z44 power sensor based on a customized (= user) standard.

See the following commands for more information about these conditions:

- `[SENSe:]PMETer:DETEctor[:FUNction] <PowerDisplay>`
- `CALCulate:PMETer:PRESet[:STATe] <State>`
- `CALCulate:PMETer:PRESet:SElect <Standard>`

List of commands

- `CALCulate:PMETer:PRESet:BANDwidth:VIDeo <Bandwidth>` (p. 153)

`CALCulate:PMETer:PRESet:BANDwidth:VIDeo <Bandwidth>`

This command defines the video bandwidth of the R&S FSH-Z44 power sensor.

Parameter

`<Bandwidth>`

Video bandwidth of the power sensor in Hz.

Example

```
CALC:PMET:PRESet:BAND:VID 10MHZ
```

Defines a video bandwidth of 10 MHz.

Characteristics

*RST value: -

SCPI: device-specific

7.4.1.7 Reading Out Measurement Results

List of commands

- `FETCh<z>:PMETer?` (p. 153)

`FETCh<z>:PMETer?`

This command queries the results of measurements with the power sensor.

Return value

The return values depend on the power sensor in use and the selected suffix at FETCh.

Measurements with R&S FSH-Z1 or R&S FSH-Z18:

```
FETC1:PMET?      power in dBm
```

```
FETC2:PMET?      n/a
```

Measurements with R&S FSH-Z14 or R&S FSH-Z44

FETC1:PMET? forward power in dBm
 FETC2:PMET? reflected power in dBm

Example

FETC2 : PMET?

Returns nothing for R&S FSH-Z1 / R&S FSH-Z18 and the reflected power for R&S FSH-Z14 / Z44.

Characteristics

*RST value: -
 SCPI: device-specific

7.4.1.8 Selecting a Telecommunication Standard

These commands apply radio communication standards to measurements with the power sensor.

Note that the selection of a standard is available only for the power sensors R&S FSH-Z1, -Z14, -Z18 and -Z44.

List of commands

- [CALCulate:PMETer:PRESet\[:STATe\] <State>](#) (p. 154)
- [CALCulate:PMETer:PRESet:SElect <Standard>](#) (p. 155)

CALCulate:PMETer:PRESet[:STATe] <State>

This command turns the use of a standard on and off.

Parameters

<State>
 ON | OFF

Example

CALC:PMET:PRESet ON
 Activates usage of a standard

Characteristics

*RST value: -
 SCPI: device-specific

CALCulate:PMETer:PRESet:SElect <Standard>

This command selects the standard for power sensor measurements.

Parameter

<Standard>

GSM | EDGE | WCDMA | CDMAOne | CDMA2000 | DVBT | DAB | TETRA | USER

Example

```
CALC:PMET:PRE:SEL GSM
```

Selects the GSM standard for power sensor measurements

Characteristics

*RST value: -

7.5 Remote Commands of the Distance-to-Fault Mode

The chapter provides information on remote commands that configure and perform two-port measurements with the tracking generator. These commands are available in distance to fault mode only.



Availability of remote commands for DTF measurements

Note that the listed remote commands take effect only if option R&S FSH-K41 Distance-to-Fault Measurements is installed.

Contents

[Configuring the Horizontal Axis](#) on page 157

[Configuring the Vertical Axis](#) on page 158

[Setting the Bandwidth](#) on page 158

[Performing and Triggering Measurements](#) on page 159

[Working with Traces](#) on page 160

[Using Markers](#) on page 162

[Configuring and Using Measurement Functions](#) on page 164

7.5.1 Configuring the Horizontal Axis

The following commands configure the horizontal axis of the active display.

List of commands

- [\[SENSe:\]FREQUency:CENTer<n> <Frequency>](#) (p. 37)
- [\[SENSe:\]FREQUency:CENTer:STEP <StepSize>](#) (p. 37)
- [\[SENSe:\]FREQUency:CENTer:STEP:LINK <StepSizeCoupling>](#) (p. 38)
- [\[SENSe:\]FREQUency:SPAN<n>](#) (p. 40)
- [\[SENSe:\]FREQUency:SPAN<n>:AUTO <State>](#) (p. 40)
- [\[SENSe:\]FREQUency:STARt<n> <StartFrequency>](#) (p. 41)
- [\[SENSe:\]FREQUency:STOP<n> <StopFrequency>](#) (p. 41)

For a detailed description of the commands refer to "[Configuring the Horizontal Axis](#)" in spectrum analyzer mode.

7.5.2 Configuring the Vertical Axis

The following commands configure the vertical axis of the active display.

The suffix <n> at DISPLAY is irrelevant.

List of commands

- [DISPlay<n>:LOSS:REFerence <RefValue>](#) (p. 121)
- [DISPlay<n>:LOSS:REFerence:POSition <RefPosition>](#) (p. 122)
- [DISPlay<n>:LOSS:Y:SCALe <DisplayRange>](#) (p. 122)
- [DISPlay<n>:MAGNitude:REFerence <RefValue>](#) (p. 123)
- [DISPlay<n>:MAGNitude:REFerence:POSition <RefPosition>](#) (p. 123)
- [DISPlay<n>:MAGNitude:Y:SCALe <DisplayRange>](#) (p. 123)
- [DISPlay<n>:MAGNitude:Y:SPACing <Scaling>](#) (p. 124)
- [DISPlay<n>:REFLection:Y:SCALe <DisplayRange>](#) (p. 126)
- [DISPlay<n>:REFLection:UNIT <Unit>](#) (p. 126)
- [DISPlay<n>:VSWR:Y:SCALe <DisplayRange>](#) (p. 127)
- [DISPlay\[:WINDow\]:TRACe<n>:Y\[:SCALe\]:ADJust](#) (p. 42)
- [INPut<n>:ATTenuation <Attenuation>](#) (p. 44)
- [INPut<n>:ATTenuation:MODE <AttenuationMode>](#) (p. 45)
- [INPut<n>:ATTenuation:AUTO <State>](#) (p. 45)

For a detailed description of commands refer to "[Configuring the Vertical Axis](#)" in spectrum analyzer mode and "[Configuring the Vertical Axis](#)" in network analyzer mode.

7.5.3 Configuring the Tracking Generator

The following commands configure the characteristics of the tracking generator of the R&S FSH.

List of commands

- [SOURce:TG:ATTenuation <Attenuation>](#) (p. 128)
- [SOURce:TG:OFFSet <Level>](#) (p. 129)
- [SOURce:TG:POWer <Level>](#) (p. 129)

7.5.4 Setting the Bandwidth

The following commands configure the filter bandwidths of the R&S FSH. Note that both groups of commands (BANDwidth and BWIDth) are the same.

List of commands

- [\[SENSe:\]BANDwidth|BWIDth<n>\[:RESolution\] <ResBW>](#) (p. 49)
- [\[SENSe:\]BANDwidth|BWIDth<n>\[:RESolution\]:AUTO <State>](#) (p. 49)

For a detailed description of commands refer to "[Setting the Bandwidths](#)" in spectrum analyzer mode.

7.5.5 Performing and Triggering Measurements

7.5.5.1 Performing the Measurement

The following commands configure the sweep.

List of commands

- [*WAI](#) (p. 35)
- [ABORt](#) (p. 51)
- [INITiate\[:IMMEDIATE\]](#) (p. 51)
- [INITiate:CONTinuous <SweepMode>](#) (p. 52)
- [\[SENSe:\]SWEep:COUNT<n> <SweepCount>](#) (p. 52)
- [\[SENSe:\]SWEep:POINts?](#) (p. 53)
- [\[SENSe:\]SWEep:TIME<n> <SweepTime>](#) (p. 53)
- [\[SENSe:\]SWEep:TIME<n>:AUTO <State>](#) (p. 53)

For a detailed description of commands refer to "[Performing and Triggering Measurements](#)" in spectrum analyzer mode.

7.5.6 Working with Traces

The following commands set up the trace and the various functions associated with it, e.g. trace mathematics or the selection of the detector.

The suffix <n> is irrelevant.

List of commands

- [DISPlay\[:WINDow\]:TRACe<n>\[:STATe\] <State>](#) (p. 61)
- [DISPlay\[:WINDow\]:TRACe<n>:MEMory\[:STATe\] <State>](#) (p. 61)
- [DISPlay\[:WINDow\]:TRACe<n>:MODE <TraceMode>](#) (p. 62)
- [FORMat\[:DATA\] <DataFormat>](#) (p. 65)
- [\[SENSe:\]DETEctor<n>\[:FUNCTioN\] <Detector>](#) (p. 63)
- [\[SENSe:\]DETEctor<n>\[:FUNCTioN\]:AUTO <State>](#) (p. 63)
- [TRACe:DATA](#) (p. 160)
- [TRACe<n>:DATA:MEMory? <Trace>](#) (p. 64)
- [UNIT:LENGth <Unit>](#) (p. 161)

For a detailed description of commands refer to "[Working with Traces](#)" in spectrum analyzer mode.

TRACe:DATA <Destination>

This command queries the current trace data.

You can set the data format with the [FORMat\[:DATA\] <DataFormat>](#).

Parameter

<Destination>

TRACE1	Queries the data of trace 1.
TRACE2	Queries the data of trace 2..

Return value

The R&S FSH returns 631 values. Each value corresponds to one pixel of a trace.

The result and unit depends on the measurement format.

Example

```
TRAC:DATA? TRACE1
```

Reads out the data for trace 1.

Characteristics

*RST value: -
SCPI: conform

UNIT:LENGth <Unit>

This command selects the length unit.

Parameter

<Unit>
METer | FEET

Example

```
UNIT:LENGth FEET
```

Selects feet as the length unit.

Characteristics

*RST value: METer
SCPI: conform

7.5.7 Using Markers

The following commands position and control markers and deltamarkers.

The suffix <n> at CALCulate is irrelevant.

The suffix <m> at MARKer selects the marker or delta marker.

List of commands

- [CALCulate<n>:DELTAmarker<m>\[:STATe\] <State>](#) (p. 66)
- [CALCulate<n>:DELTAmarker<m>:AOFF](#) (p. 67)
- [CALCulate<n>:DELTAmarker<m>:MAXimum\[:PEAK\]](#) (p. 67)
- [CALCulate<n>:DELTAmarker<m>:MAXimum:NEXT](#) (p. 67)
- [CALCulate<n>:DELTAmarker<m>:MINimum\[:PEAK\]](#) (p. 68)
- [CALCulate<n>:DELTAmarker<m>:X <Coordinate>](#) (p. 68)
- [CALCulate<n>:DELTAmarker<m>:X:RELative <Distance>](#) (p. 69)
- [CALCulate<n>:DELTAmarker<m>:Y?](#) (p. 69)
- [CALCulate<n>:MARKer<m>\[:STATe\] <State>](#) (p. 70)
- [CALCulate<n>:MARKer<m>:AOFF](#) (p. 70)
- [CALCulate<n>:MARKer<m>:MAXimum\[:PEAK\]](#) (p. 70)
- [CALCulate<n>:MARKer<m>:MAXimum:NEXT](#) (p. 71)
- [CALCulate<n>:MARKer<m>:MINimum\[:PEAK\]](#) (p. 71)
- [CALCulate<n>:MARKer<m>:X <Coordinate>](#) (p. 71)
- [CALCulate<n>:MARKer<m>:X:SLIMits\[:STATe\] <State>](#) (p. 72)
- [CALCulate<n>:MARKer<m>:X:SLIMits:LEFT <SearchLimit>](#) (p. 72)
- [CALCulate<n>:MARKer<m>:X:SLIMits:RIGHT <Searchlimit>](#) (p. 73)
- [CALCulate<n>:MARKer<m>:Y?](#) (p. 73)

For a detailed description of commands refer to "Using Markers" in spectrum analyzer mode.

7.5.8 Using Limit Lines

The following commands define limit lines and perform the corresponding limit checks.

The suffix <n> at CALCulate is irrelevant.

The suffix <k> at LIMit selects the limit line and is in the range {1...2}.

List of commands

- [CALCulate<n>:LIMit<k>:BEEP\[:STATe\] <State>](#) (p. 83)
- [CALCulate<n>:LIMit<k>:COMMeNt?](#) (p. 83)
- [CALCulate<n>:LIMit<k>:DELeTe](#) (p. 85)
- [CALCulate<n>:LIMit<k>:FAIL?](#) (p. 85)
- [CALCulate<n>:LIMit<k>:LOWer:SELeCt <LimitLine>](#) (p. 85)
- [CALCulate<n>:LIMit<k>:STATe <State>](#) (p. 86)
- [CALCulate<n>:LIMit<k>:UNIT:X?](#) (p. 86)
- [CALCulate<n>:LIMit<k>:UNIT\[:Y\]?](#) (p. 87)
- [CALCulate<n>:LIMit<k>:UPPer:SELeCt <LimitLine>](#) (p. 87)

For a detailed description of all commands not included here, refer to "[Using Display Lines and Limit Lines](#)" in spectrum mode.

7.5.9 Configuring and Using Measurement Functions

This chapter provides information on how to configure two-port measurements with the tracking generator. The structure follows the order of the actual operation sequence used when performing a measurement:

- [Selecting the Cable Characteristics](#) on page 164
- [Selecting the Measurement Mode](#) on page 165
- [Calibrating the Measurement](#) on page 166

To perform the actual measurement, use the commands described in section "[Performing and Triggering Measurements](#)".

7.5.9.1 Selecting the Cable Characteristics

The following commands define the cable characteristics for the cable you are testing.

List of commands

- [CALCulate:DTF:CABLE:LENGth <CableLength>](#) (p. 164)
- [CALCulate:DTF:CABLE:PRESet <CableModel>](#) (p. 164)

CALCulate:DTF:CABLE:LENGth <CableLength>

This command sets the cable length.

Parameter

<CableLength>

3 to 1500 m

Example

```
CALCulate:DTF:CAB:LENG 2 M
```

Sets the cable length to 2 meter.

Characteristics

*RST value: 20 m

SCPI: device-specific

CALCulate:DTF:CABLE:PRESet <CableModel>

This command selects the cable model.

Parameter

<CableModel>

String containing the file name of the cable model.

Example

```
CALC:DTF:CAB:PRES '5088-HLFR.CBLMOD'
```

Selects the cable model from the file 5088-HLFR.CBLMOD

Characteristics

*RST value: -
 SCPI: device-specific

7.5.9.2 Selecting the Measurement Mode

The following commands select the measurement mode.

List of commands

- [MEASurement:MODE <MeasMode>](#) (p. 165)

MEASurement:MODE <MeasMode>

This command selects the measurement mode.

Parameter

<MeasMode>

DTFault	Selects the distance-to-fault measurement.
LOSS	Selects the cable loss measurement.
REFlection	Selects the reflection measurement (S11)

Example

```
MEAS:MODE LOSS
```

Activates cable loss measurement.

Characteristics

*RST value: DTFault
 SCPI: device-specific

7.5.9.3 Reading Out Measurement Results

The following commands query various measurement results.

List of commands

- [CALCulate:TRACe:CABLe:LOSS:RESult?](#) (p. 165)

CALCulate:TRACe:CABLe:LOSS:RESult?

This command queries the cable loss measurement result.

Return values

Cable loss in dB.

Example

```
CALC:TRAC:CABL:LOSS:RES?
```

Returns the cable loss.

Characteristics

*RST value: -

SCPI: device-specific

7.5.9.4 Calibrating the Measurement

The following commands control calibration of cable measurements.

List of commands

- [CALibration:ABORt](#) (p. 166)
- [CALibration:ATTenuation:STATus?](#) (p. 166)
- [CALibration:CONTInue?](#) (p. 167)
- [CALibration:MODE?](#) (p. 141)
- [CALibration:START? <CalibrationMethod>](#) (p. 167)
- [CALibration:STATus?](#) (p. 141)

For a detailed description of commands refer to "[Calibrating the Measurement](#)" in network analyzer mode.

CALibration:ABORt

This command aborts calibration.

This command is an event and therefore has no query and no *RST value.

Example

```
CAL:ABOR
```

Aborts calibration.

Characteristics

*RST value: -

SCPI: device-specific

CALibration:ATTenuation:STATus?

This command queries the current calibration state.

This command is a query and therefore has no *RST value.

Return values

NORMALized full calibration

APPROximate approximate calibration (caused by a change of attenuation, for example): measurement uncertainty must be anticipated

Example

```
CAL:STAT?
```

Queries the calibration status of the R&S FSH.

Characteristics

*RST value: -

SCPI: device-specific

CALibration:CONTinue?

This command resumes calibration after a calibration standard has been connected.

After the command has been sent, it returns instructions on what to do to continue the calibration process and finish it successfully.

This command is a query and therefore has no *RST value.

Example

```
CAL:CONT?
```

Resumes calibration and would return, e.g.:

```
'Connect Load to Port 1'
```

Connect the load before resuming calibration.

Characteristics

*RST value: -

SCPI: device-specific

CALibration:START? <CalibrationMethod>

This command selects a calibration method and initiates calibration.

After the command has been sent, it returns instructions on what to do to continue the calibration process and finish it successfully.

This command is a query and therefore has no *RST value.

Parameter

<CalibrationMethod>

F2PCal	Full 2-Port calibration (network analysis only)
F2PNorm	Normalize full 2-Port (network analysis only)
F2PHighacc	Full 2-Port High Accuracy
FULL	Reflection Port 2 and Transmission Rev
S11Cal	Reflection Port 1 calibration
S11easy	Easy 1-Port calibration (Port 1) (network analysis only)
S11Norm	Normalize reflection port 1
S12Cal	Transmission Rev (Port 2 ► 1) calibration (network analysis only)

S12Norm	Normalize transmission reverse (Port 2 ► 1) (network analysis only)
S21Cal	Transmission Fwd (Port 1 ► 2) calibration (network analysis only)
S21Norm	Normalize transmission forward (Port 1 ► 2) (network analysis only)
S22Cal	Reflection Port 2 calibration
S22easy	Easy 1-Port calibration (Port 2) (network analysis only)
S22Norm	Normalize reflection port 2

Return values

<Instructions>

Connect Open to Port 1	Connect the open to port 1 before resuming calibration.
Connect Open to Port 2	Connect the open to port 2 before resuming calibration.
Connect Short to port 1	Connect the short to port 1 before resuming calibration.
Connect Short to port 2	Connect the short to port 2 before resuming calibration.
Connect Load to port 1	Connect the short to port 1 before resuming calibration.
Connect Load to port 2	Connect the short to port 2 before resuming calibration.
Connect Through	Connect a through to ports 1 and 2.
Disconnect DUT from port 1	
Disconnect DUT from port 2	
Calibration done	Calibration has been finished. No further actions required

Example

```
CAL:STAR? F2PCal
```

Selects and initiates a full 2-port calibration and would return, e.g.:

```
'Connect Open to Port 1'
```

Connect the open before resuming calibration.

Characteristics

*RST value: -

SCPI: device-specific

7.5.9.5 Working with a DTF List

The following commands configure the DTF peak list. The peak list is available for DTF measurements only.

List of commands

- [CALCulate:TRANSform:DTFault:PEAK:COUNT?](#) (p. 169)
- [CALCulate:TRANSform:DTFault:PEAK:DATA<y>?](#) (p. 169)
- [CALCulate:TRANSform:DTFault:PEAK\[:STATE\] <State>](#) (p. 169)
- [CALCulate:TRANSform:DTFault:PEAK:THRshold <Threshold>](#) (p. 170)

CALCulate:TRANSform:DTFault:PEAK:COUNT?

This command queries the number of entries in the DTF list.

Return value

<DTFListEntries>

Example

```
CALC:TRAN:DTF:PEAK:COUN?
```

Queries the number of values in the DTF list.

Characteristics

*RST value: -

SCPI: device-specific

CALCulate:TRANSform:DTFault:PEAK:DATA<y>?

This command queries the DTF list.

This command is a query and therefore has no *RST value.

Suffix

<y>

Selects an entry in the DTF list.

Return value

<distance>,<return loss>

The number of values depends on the number of peaks that exceed the threshold you can set with [CALCulate:TRANSform:DTFault:PEAK:THReshold <Threshold>](#).

Example

```
CALC:TRAN:DTF:PEAK:RES2?
```

Reads out the second result in the DTF peak list.

Characteristics

*RST value: -

SCPI: device-specific

CALCulate:TRANSform:DTFault:PEAK[:STATe] <State>

This command turns the display of the DTF list on and off.

Parameter

ON | OFF

Example

```
CALC:TRAN:DTF:PEAK ON
```

Turns on the DTF peak list.

Characteristics

*RST value: -
SCPI: device-specific

CALCulate:TRANSform:DTFault:PEAK:THReshold <Threshold>

This commands defines the threshold for the DTF list.

All values that exceed the threshold are in the DTF list. You can query the list with [CALCulate:TRANSform:DTFault:PEAK:DATA<y>?](#).

Parameter

<Threshold>

Numeric value that sets the threshold level.

The unit depends on the measurement format.

Example

```
CALC:TRAN:DTF:PEAK:THR -20
```

Sets the threshold to -20 dB

Characteristics

*RST value: -
SCPI: device-specific

7.6 Remote Commands of the Receiver Mode

The chapter provides information on remote commands that configure and perform measurements receiver.



Availability of remote commands for EMI measurements

Note that the listed remote commands take effect only if option R&S FSH-K43 EMI Measurements is installed.

Contents

[Configuring the Horizontal Axis](#) on page 172

[Configuring the Vertical Axis](#) on page 174

[Setting the Bandwidth](#) on page 175

[Performing and Triggering the Measurement](#) on page 176

[Working with Traces](#) on page 178

[Using Markers](#) on page 180

7.6.1 Configuring the Horizontal Axis

The following commands configure the horizontal (frequency) axis of the active display.

The suffix <n> in the following commands is irrelevant.

List of commands

- [\[SENSe:\]CHANnel<n> <ChannelNumber>](#) (p. 89)
- [\[SENSe:\]FREQuency:CENTer<n> <Frequency>](#) (p. 37)
- [\[SENSe:\]FREQuency:CENTer:STEP <StepSize>](#) (p. 37)
- [\[SENSe:\]FREQuency:INPut:MODE<n> <InputMode>](#) (p. 38)
- [\[SENSe:\]FREQuency:MODE <OperationMode>](#) (p. 172)
- [\[SENSe:\]SCAN:STARt <StartFrequency>](#) (p. 172)
- [\[SENSe:\]SCAN:STEP <StepSize>](#) (p. 173)
- [\[SENSe:\]SCAN:STOP <StopFrequency>](#) (p. 173)

For a detailed description of all commands not included here refer to "[Configuring the Horizontal Axis](#)" in spectrum analyzer mode.

[SENSe:]FREQuency:MODE <OperationMode>

This command sets up the R&S FSH for frequency domain or time domain measurements.

In scan mode, set the frequency with:

- [\[SENSe:\]SCAN:STARt <StartFrequency>](#)
- [\[SENSe:\]SCAN:STOP <StopFrequency>](#)

For more information see [\[SENSe:\]FREQuency:MODE <OperationMode>](#).

Parameter

<OperationMode>

CW	Time domain measurements (span = 0).
FIXed	Time domain measurements (span = 0).
SCAN	Frequency domain measurements (span > 0).

Example

```
FREQ:MODE SCAN
```

Activates frequency domain measurements.

Characteristics

*RST value: FIXed

SCPI: conform

[SENSe:]SCAN:STARt <StartFrequency>

This command defines the start frequency of the receiver scan range.

Parameter

<StartFrequency>

Numeric value in Hz.

The range is specified in the datasheet.

Example

```
SCAN:STAR 30kHz
```

Defines a start frequency of 30 kHz.

Characteristics

*RST value: f_{\min}

SCPI: device-specific

[SENSe:]SCAN:STEP <StepSize>

This command defines the step size in the receiver scan range.

Parameter

<StepSize>

Numeric value in Hz.

The range is from 1 Hz to f_{\max} .

Example

```
SCAN:STEP 1kHz
```

Defines a step frequency of 1 kHz.

Characteristics

*RST value: 0

SCPI: device-specific

[SENSe:]SCAN:STOP <StopFrequency>

This command defines the stop frequency of the receiver scan range.

Parameter

<StopFrequency>

Numeric value in Hz.

The range is specified in the datasheet.

Example

```
SCAN:STOP 1GHz
```

Defines a start frequency of 1 GHz.

Characteristics

*RST value: f_{\max}

SCPI: device-specific

7.6.2 Configuring the Vertical Axis

The following commands configure the vertical (level) axis and level parameters of the active display.

The suffix <n> at TRACe is irrelevant for these commands.

The suffix <c> at TRANsducer selects the primary or secondary transducer. The range is <1...2>.

List of commands

- DISPLAY[:WINDow]:TRACe<n>:Y:SPACing <Scaling> (p. 42)
- DISPLAY[:WINDow]:TRACe<n>:Y[:SCALe] <DisplayRange> (p. 43)
- DISPLAY[:WINDow]:TRACe<n>:Y[:SCALe]:RLEVel <ReferenceLevel> (p. 43)
- DISPLAY[:WINDow]:TRACe<n>:Y[:SCALe]:RLEVel:OFFSet <Offset> (p. 44)
- DISPLAY[:WINDow]:TRACe:Y[:SCALe]:RPOSition <ReferencePosition> (p. 44)
- INPut<n>:ATTenuation <Attenuation> (p. 44)
- INPut<n>:ATTenuation:MODE <AttenuationMode> (p. 45)
- INPut<n>:ATTenuation:AUTO <State> (p. 45)
- INPut<n>:GAIN:STATE <State> (p. 46)
- INPut:IMPedance <Impedance> (p. 46)
- [SENSe:]CORRection:TRANsducer<c>[:STATE] <State> (p. 46)
- [SENSe:]CORRection:TRANsducer<c>:SELect <TransducerFactor> (p. 47)
- [SENSe:]CORRection:TRANsducer<c>:UNIT? (p. 47)
- UNIT<n>:POWER <Unit> (p. 48)

For a detailed description of all commands not included here refer to "[Configuring the Vertical Axis](#)" in spectrum analyzer mode.

7.6.3 Setting the Bandwidth

The following commands configure the filter bandwidths of the R&S FSH. Note that both groups of commands (BANDwidth and BWIDth) are the same.

List of commands

- [\[SENSe:\]BANDwidth|BWIDth<n>\[:RESolution\] <ResBW>](#) (p. 49)
- [\[SENSe:\]BANDwidth\[:RESolution\]:CISPr <CISPRBandwidth>](#) (p. 175)
- [\[SENSe:\]BANDwidth\[:RESolution\]:CISPr:AUTO <State>](#) (p. 175)

For a detailed description of commands refer to "[Setting the Bandwidths](#)" in spectrum analyzer mode.

[SENSe:]BANDwidth[:RESolution]:CISPr <CISPRBandwidth>

This command defines the CISPR (6 dB) bandwidth for CISPR conform measurements.

Parameter

<CISPRBandwidth>
200 Hz | 9 kHz | 120 kHz | 1 MHz

Example

```
BAND:CISP 120KHZ
```

Defines a bandwidth of 120 kHz.

Characteristics

*RST value: - (AUTO is on)
SCPI: device-specific

[SENSe:]BANDwidth[:RESolution]:CISPr:AUTO <State>

This command turns automatic selection of the CISPR measurement bandwidth on and off.

Parameter

<State>
ON | OFF

Example

```
BAND:CISP:AUTO ON
```

Turns automatic selection of the CISPR bandwidth on.

Characteristics

*RST value: ON
SCPI: device-specific

7.6.4 Performing and Triggering the Measurement

The following commands configure the sweep.

The suffix <n> in the following commands is irrelevant.

7.6.4.1 Performing the Measurement

List of commands

- [*WAI](#) (p. 35)
- [ABORt](#) (p. 51)
- [INITiate\[:IMMediate\]](#) (p. 51)
- [INITiate:CONTinuous <SweepMode>](#) (p. 52)
- [\[SENSe:\]SWEEp:COUNT<n> <SweepCount>](#) (p. 52)
- [\[SENSe:\]SWEEp:TIME <MeasurementTime>](#) (p. 176)

For a detailed description of commands refer to "[Performing and Triggering Measurements](#)" in spectrum analyzer mode.

[SENSe:]SWEEp:TIME <MeasurementTime>

This command defines the measurement time.

Parameter

<MeasurementTime>
Numeric value in seconds.

The available value range is specified in the datasheet.

Example

```
SWE:TIME 10s
Sets the measurement time to 10 s
```

Characteristics

*RST value: 100 ms
SCPI: conform

7.6.4.2 Triggering Measurements

The following commands set up trigger conditions if you are using a trigger for the measurement.

List of commands

- [TRIGger<n>\[:SEquence\]:HOLDoff\[:TIME\] <TriggerDelay>](#) (p. 58)
- [TRIGger<n>\[:SEquence\]:SLOPe <TriggerSlope>](#) (p. 58)
- [TRIGger\[:SEquence\]:SOURce <TriggerSource>](#) (p. 177)

For a detailed description of all commands not included here, refer to "[Performing and Triggering Measurements](#)" in spectrum analyzer mode.

TRIGger[:SEQuence]:SOURce <TriggerSource>

This command selects the trigger source.

Parameter

<TriggerSource>

IMMediate	Free Run measurements.
EXTernal	External trigger.

For more information see R&S FSH operating manual chapter "Setting the Sweep"

Example

```
TRIG:SOUR EXT
```

Selects the external trigger input as source of the trigger signal

Characteristics

*RST value: IMMediate

SCPI: conform

7.6.4.3 Using an Isotropic Antenna

The following commands set up measurements with an isotropic antenna.

You can use an isotropic antenna with all measurement modes that are described above.

List of commands

- [INPut:ANTenna:MEASure <Direction>](#) (p. 117)
- [INPut:ANTenna:STATe <State>](#) (p. 118)
- [\[SENSe:\]CORRection:TRANsducer<c>:ISOTropic\[:STATe\]?](#) (p. 118)

For a detailed description of the commands refer to "[Using an Isotropic Antenna](#)" in spectrum analyzer mode.

7.6.5 Working with Traces

The following commands set up the trace and the various functions associated with it, e.g. trace mathematics or the selection of the detector.

List of commands

- [CALCulate:MATH<n>:COPY:MEMory](#) (p. 60)
- [DISPlay\[:WINDow\]:TRACe<n>\[:STATe\] <State>](#) (p. 61)
- [DISPlay\[:WINDow\]:TRACe<n>:MEMory\[:STATe\] <State>](#) (p. 61)
- [DISPlay\[:WINDow\]:TRACe<n>:MODE <TraceMode>](#) (p. 62)
- [DISPlay\[:WINDow\]:TRACe:STYLe <Style>](#) (p. 178)
- [FORMat:BORDER <ByteOrder>](#) (p. 62)
- [\[SENSe:\]DETEctor<n>\[:FUNCTioN\] <Detector>](#) (p. 178)
- [TRACe:DATA?](#) (p. 179)
- [TRACe<n>:DATA:MEMory? <Trace>](#) (p. 64)
- [FORMat\[:DATA\] <DataFormat>](#) (p. 65)

For a detailed deescription of all commands not included here, refer to "[Working with Traces](#)" in spectrum analyzer mode.

DISPlay[:WINDow]:TRACe:STYLe <Style>

This command selects the style of the trace display.

Parameters

LINes	Shows the results in form of a line trace with interpolation between the receiver frequencies.
POLYgon	Shows the results in form of vertical lines at each receiver frequency.

Example

```
DISP:TRAC:STYL LIN
Selects the display of a line trace.
```

Characteristics

*RST value: POLYgon
SCPI: conform

[SENSe:]DETEctor<n>[:FUNCTioN] <Detector>

This command selects the detector.

Parameter

<Detector>
AVERage | POSitive | QUASipeak | RMS

For more information see the operating manual, chapter "Detectors".

Example

```
DET POS
```

Sets the detector to "positive peak".

Characteristics

*RST value: POS

SCPI: conform

TRACe:DATA?

This command reads out the trace data of the current measurement.

Parameters

Returns the results of a scan measurement.

The number of values depends on the scan settings.

Example

```
TRAC:DATA? SCAN
```

Returns the results of the scan measurement.

Characteristics

*RST value: -

SCPI: conform

7.6.6 Using Markers

- [Markers and Delta Markers](#) on page 180.
- [Marker Functions](#) on page 180.

7.6.6.1 Markers and Delta Markers

The following commands are for setting and controlling markers and deltamarkers.

The suffix <n> in the following commands is irrelevant.

The suffix <m> at MARKer is in the range {1..6} and selects the marker or deltamarker.

List of commands

- [CALCulate<n>:DELTamarker<m>\[:STATe\] <State>](#) (p. 66)
- [CALCulate<n>:DELTamarker<m>:AOFF](#) (p. 67)
- [CALCulate<n>:DELTamarker<m>:MAXimum\[:PEAK\]](#) (p. 67)
- [CALCulate<n>:DELTamarker<m>:MAXimum:NEXT](#) (p. 67)
- [CALCulate<n>:DELTamarker<m>:MINimum\[:PEAK\]](#) (p. 68)
- [CALCulate<n>:DELTamarker<m>:X <Coordinate>](#) (p. 68)
- [CALCulate<n>:DELTamarker<m>:X:RELative <Distance>](#) (p. 69)
- [CALCulate<n>:DELTamarker<m>:Y?](#) (p. 69)
- [CALCulate<n>:MARKer<m>\[:STATe\] <State>](#) (p. 70)
- [CALCulate<n>:MARKer<m>:AOFF](#) (p. 70)
- [CALCulate<n>:MARKer<m>:MAXimum\[:PEAK\]](#) (p. 70)
- [CALCulate<n>:MARKer<m>:MAXimum:NEXT](#) (p. 71)
- [CALCulate<n>:MARKer<m>:MINimum\[:PEAK\]](#) (p. 71)
- [CALCulate<n>:MARKer<m>:X <Coordinate>](#) (p. 71)
- [CALCulate<n>:MARKer<m>:X:SLIMits\[:STATe\] <State>](#) (p. 72)
- [CALCulate<n>:MARKer<m>:X:SLIMits:LEFT <SearchLimit>](#) (p. 72)
- [CALCulate<n>:MARKer<m>:X:SLIMits:RIGHT <Searchlimit>](#) (p. 73)
- [CALCulate<n>:MARKer<m>:Y?](#) (p. 73)

For a detailed description of commands refer to "[Using Markers](#)" in spectrum analyzer mode.

7.6.6.2 Marker Functions

The following commands perform various kinds of analysis at the marker position.

The suffix <m> at MARKer is irrelevant, except where noted.

List of commands

- [CALCulate:MARKer<m>:FREQuency:MODE <InputMode>](#) (p. 76)
- [CALCulate:MARKer<m>:FUNction:DEModulation\[:STATe\] <State>](#) (p. 77)
- [CALCulate:MARKer<m>:FUNction:DEModulation:HOLDoff <Time>](#) (p. 77)
- [CALCulate:MARKer<m>:FUNction:DEModulation:SElect <Demodulation>](#) (p.78)

For a detailed description of commands refer to "[Using Markers](#)" in spectrum analyzer mode.

7.6.7 Using Limit Lines

The following commands define limit lines and perform the corresponding limit checks.

The suffix <n> at CALCulate is irrelevant.

The suffix <k> at LIMit selects the limit line and is in the range {1...2}.

List of commands

- [CALCulate<n>:LIMit<k>:BEEP\[:STATe\] <State>](#) (p. 83)
- [CALCulate<n>:LIMit<k>:COMMeNt?](#) (p. 83)
- [CALCulate<n>:LIMit<k>:DEFine](#) (p. 84)
- [CALCulate<n>:LIMit<k>:DELete](#) (p. 85)
- [CALCulate<n>:LIMit<k>:FAIL?](#) (p. 85)
- [CALCulate<n>:LIMit<k>:LOWer:SELect <LimitLine>](#) (p. 85)
- [CALCulate<n>:LIMit<k>:STATe <State>](#) (p. 86)
- [CALCulate<n>:LIMit<k>:UNIT:X?](#) (p. 86)
- [CALCulate<n>:LIMit<k>:UNIT\[:Y\]?](#) (p. 87)
- [CALCulate<n>:LIMit<k>:UPPer:SELect <LimitLine>](#) (p. 87)

For a detailed description of the commands refer to "[Using Display Lines and Limit Lines](#)" in spectrum analyzer mode.

7.7 Remote Commands of the Digital Modulation Analyzer

The chapter provides information on remote commands that configure and perform measurements with the digital modulation analyzer. These commands are available in digital modulation mode only.



Availability of remote commands for the digital modulation analyzer

Note that the listed remote commands take effect only if the corresponding application is installed on the R&S FSH.

Contents

[Performing Measurements on GSM Signals](#) on page 183

[Performing Measurements on 3GPP WCDMA Signals](#) on page 197

[Performing Measurements on CDMA2000 Signals](#) on page 212

[Performing Measurements on 1xEV-DO Signals](#) on page 221

[Performing Measurements on TD-SCDMA Signals](#) on page 229

[Performing Measurements on LTE Signals](#) on page 240

7.7.1 Performing Measurements on GSM Signals

When you perform measurements on GSM signals, you can use the remote commands described in this chapter.



Availability of remote commands

Note that the listed remote commands take effect only if option R&S FSH-K10 is installed.

7.7.1.1 Setting the Frequency

The following commands configure the frequency axis (x-axis) of the active display. The suffix <n> in the following commands is irrelevant.

List of commands

- [\[SENSe:\]CHANnel](#) (p. 89)
- [\[SENSe:\]FREQUency:CENTer<n> <Frequency>](#) (p. 37)
- [\[SENSe:\]FREQUency:CENTer:STEP](#) (p. 37)
- [\[SENSe:\]FREQUency:CENTer:STEP:LINK](#) (p. 38)
- [\[SENSe:\]FREQUency:INPut:MODE](#) (p. 38)

For a detailed description of the commands refer to "[Configuring the Horizontal Axis](#)" in spectrum analyzer mode.

7.7.1.2 Setting Amplitude Parameters

The following commands configure the level axis (y-axis) and level parameters of the active display.

The suffix <n> in the following commands is irrelevant.

List of commands

- [CALCulate:MARKer:FUNCTion:LEVel ONCE](#) (p. 183)
- [DISPlay\[:WINDow\]:TRACe<n>:Y\[:SCALe\]:RLEVel](#) (p. 43)
- [DISPlay\[:WINDow\]:TRACe<n>:Y\[:SCALe\]:RLEVel:OFFSet](#) (p. 44)
- [INPut<n>:ATTenuation <Attenuation>](#) (p. 44)
- [INPut<n>:ATTenuation:MODE](#) (p. 45)
- [INPut<n>:ATTenuation:AUTO](#) (p. 45)
- [INPut<n>:GAIN:STATe](#) (p. 46)

For a detailed description of commands not described below refer to "[Configuring the Vertical Axis](#)" in spectrum analyzer mode.

CALCulate:MARKer:FUNCTion:LEVel ONCE

This command initiates an automatic level adjustment.

Parameter

ONCE

Example

CALC:MARK:FUNC:LEV ONCE

Initiates a measurement to determine the ideal reference level.

Characteristics

*RST value: 'XTIM:CDP:ERR:SUMM'

SCPI: device-specific

7.7.1.3 Setting the Bandwidths

The following commands configure the filter bandwidths of the R&S FSH. Note that both groups of commands (BANDwidth and BWIDth) are the same.

The suffix <n> in the following commands is irrelevant.

List of commands:

- [\[SENSE\]:BANDwidth|BWIDth<n>\[:RESolution\] <ResBW>](#) (p. 49)
- [\[SENSE\]:BANDwidth|BWIDth<n>\[:RESolution\]:AUTO <State>](#) (p. 49)

For a detailed description of commands refer to "[Setting the Bandwidths](#)" in spectrum analyzer mode.

7.7.1.4 Working with Traces

The following commands set up the trace and the various functions associated with it, e.g. the selection of the detector.

The suffix <n> in the following commands is irrelevant.

List of commands

- [DISPlay\[:WINDow\]:TRACe<n>:MEMory\[:STATe\] <State>](#) (p. 61)
- [DISPlay\[:WINDow\]:TRACe<n>:MODE <TraceMode>](#) (p. 62)
- [DISPlay\[:WINDow\]:TRACe<n>\[:STATe\] <State>](#) (p. 61)

For a detailed description of commands refer to "[Working with Traces](#)" in spectrum analyzer mode.

7.7.1.5 Performing and Triggering the Measurement

The following commands initialize a measurement and set up the sweep.

List of commands

- [*WAI](#) (p. 35)
- [ABORt](#) (p. 51)
- [INITiate\[:IMMediate\]](#) (p. 51)

- [INITiate:CONTInuous <SweepMode>](#) (p. 52)

For a detailed description of commands refer to "[Performing and Triggering Measurements](#)" in spectrum analyzer mode.

7.7.1.6 Using Markers

The following commands control markers. In the 3GPP application, markers are available in the spectrum overview and isotropic antenna result displays only.

The suffix <n> in the following commands is irrelevant.

The suffix <m> in the following commands selects the marker or deltamarker and is in the range from {1...6}.

List of commands

- [CALCulate<n>:DELTamarker<m>\[:STATe\] <State>](#) (p. 66)
- [CALCulate<n>:DELTamarker<m>:AOFF](#) (p. 67)
- [CALCulate<n>:DELTamarker<m>:MAXimum\[:PEAK\]](#) (p. 67)
- [CALCulate<n>:DELTamarker<m>:MAXimum:NEXT](#) (p. 67)
- [CALCulate<n>:DELTamarker<m>:MINimum\[:PEAK\]](#) (p. 68)
- [CALCulate<n>:DELTamarker<m>:X <Coordinate>](#) (p. 68)
- [CALCulate<n>:DELTamarker<m>:X:RELative <Distance>](#) (p. 69)
- [CALCulate<n>:MARKer<m>\[:STATe\] <State>](#) (p. 70)
- [CALCulate<n>:MARKer<m>:AOFF](#) (p. 70)
- [CALCulate<n>:MARKer<m>:MAXimum\[:PEAK\]](#) (p. 70)
- [CALCulate<n>:MARKer<m>:MAXimum:NEXT](#) (p. 71)
- [CALCulate<n>:MARKer<m>:MINimum\[:PEAK\]](#) (p. 71)
- [CALCulate<n>:MARKer<m>:X <Coordinate>](#) (p. 71)

For a detailed description of commands refer to "[Using Markers](#)" in spectrum analyzer mode.

7.7.1.7 Working with Channel Tables

Use the following commands to work with channel tables.

List of commands

- [\[SENSe:\]CHANnel:TABLE:SElect <ChannelTable>](#) (p. 89)

For a detailed description of commands refer to "[Working with Channel Tables](#)" in spectrum analyzer mode.

7.7.1.8 Selecting the Result Display

The following commands select the result display.

List of commands

- [CALCulate:FEED <ResultDisplay>](#) (p. 186)

CALCulate:FEED <ResultDisplay>

This command selects the result display.

Parameter

<ResultDisplay>

'XPOWer:BURSt'	Selects the Burst Power.
'XPOWer:CPOWer'	Selects the Spectrum Overview.
'XTIMe:CDPower:ERRor:SUMMery'	Selects the Result Summary.

Example

```
CALC:FEED 'XPOW:CPOW'
```

Selects the spectrum overview result display.

Characteristics

*RST value: 'XTIM:CDP:ERR:SUMM'

SCPI: device-specific

7.7.1.9 Configuring the Measurement

The following commands configure distance-to-fault measurements. To perform the actual measurement, use the commands described in section "[Performing and Triggering the Measurement](#)".

List of commands

- [\[SENSe:\]BURSt:TSC <Sequence>](#) (p. 187)
- [\[SENSe:\]BURSt:TSC:AUTO <State>](#) (p. 187)
- [\[SENSe:\]BURSt:SLOT <Slot>](#) (p. 188)
- [\[SENSe:\]BURSt:SLOT:AUTO <State>](#) (p. 188)

[SENSe:]BURSt:TSC <Sequence>

This command selects a particular training sequence.

Parameter

<Sequence>

Number of the training sequence (0 to 7).

Example

```
BURSt:TSC 2
```

Selects training sequence 2.

Characteristics

*RST value: - (AUTO is on)

SCPI: device-specific

[SENSe:]BURSt:TSC:AUTO <State>

This command turns automatic selection of the training sequence on and off.

Parameter

<State>

ON | OFF

Example

```
BURS:TSC:AUTO ON
```

Turns automatic selection of the training sequence on and off.

Characteristics

*RST value: ON

SCPI: device-specific

[SENSe:]BURSt:SLOT <Slot>

This command selects the time slot you want to analyze.

Parameter

<Slot>

Slot number between 0 and 7.

Example

```
BURS:SLOT 0
```

Analyzes the first slot of the GSM frame.

Characteristics

*RST value: - (AUTO is on)

SCPI: device-specific

[SENSe:]BURSt:SLOT:AUTO <State>

This command turns automatic selection of the analyzed time slot on and off.

Parameter

<State>

ON | OFF

Example

```
BURS:SLOT:AUTO OFF
```

Turns automatic selection of the analyzed slot off.

Characteristics

*RST value: ON

SCPI: device-specific

7.7.1.10 Getting Measurement Results

The following commands retrieve the results of the current measurement.

List of commands

- [FETCh:BURSt\[:BTS\]:BSIC?](#) (p. 189)
- [FETCh:BURSt\[:BTS\]:MODulation?](#) (p. 189)
- [FETCh:BURSt\[:BTS\]:OCCupiedbw?](#) (p. 190)

- [FETCh:BURSt\[:BTS\]:PBUrSt?](#) (p. 190)
- [FETCh:BURSt\[:BTS\]:PTOTal?](#) (p. 190)
- [FETCh:BURSt\[:BTS\]:SLOTused?](#) (p. 191)
- [FETCh:BURSt\[:BTS\]:TRAFfic?](#) (p. 191)
- [FETCh:BURSt\[:BTS\]:TSC?](#) (p. 191)
- [FETCh:BURSt\[:MACCuracy\]:ALL?](#) (p. 192)
- [FETCh:BURSt\[:MACCuracy\]:BPOWer:CURRent?](#) (p. 192)
- [FETCh:BURSt\[:MACCuracy\]:CTOI:RMS:CURRent?](#) (p. 192)
- [FETCh:BURSt\[:MACCuracy\]\[:EVM\]:PEAK:CURRent?](#) (p. 193)
- [FETCh:BURSt\[:MACCuracy\]\[:EVM\]:SLOT:CURRent?](#) (p. 193)
- [FETCh:BURSt\[:MACCuracy\]:FREQuency:CURRent?](#) (p. 193)
- [FETCh:BURSt\[:MACCuracy\]:IQOFfset:CURRent?](#) (p. 194)
- [FETCh:BURSt\[:MACCuracy\]:MERRor:RMS:CURRent?](#) (p. 194)
- [FETCh:BURSt\[:MACCuracy\]:PERRor:RMS:CURRent?](#) (p. 194)
- [\[SENSe:\]BWIth:OCCupied?](#) (p. 195)
- [TRACe\[:DATA\] <Trace>](#) (p. 195)

FETCh:BURSt[:BTS]:BSIC?

This command queries the base station identifier code (BSIC).

Return value

<BSIC>

Numeric value that represents the BSIC.

Example

```
FETC:BURS:BSIC?
```

Queries the BSIC.

Characteristics

*RST value: -

SCPI: device-specific

FETCh:BURSt[:BTS]:MODulation?

This command queries the modulation type of the time slots in the analyzed frame.

Return value

<Modulation>

String containing 8 characters. Each character stands for the modulation type of one of the time slots.

Possible values are:

- D: dummy burst
- E: normal burst (EDGE / 8PSK modulation)
- F: frequency correction burst
- I: idle burst
- N: normal burst (GMSK modulation)
- S: synchronisation burst

Example

```
FETC: BURS: MOD?
```

Queries the modulation of the time slots.

Characteristics

*RST value: -

SCPI: device-specific

FETCh: BURSt[:BTS]: OCCupiedbw?

This command queries the occupied bandwidth of the signal.

Return value

<OccupiedBandwidth>

Bandwidth in Hz that contains 99% of the channel power.

Example

```
FETC: BURS: OCC?
```

Queries the occupied bandwidth.

Characteristics

*RST value: -

SCPI: device-specific

FETCh: BURSt[:BTS]: PBURst?

This command queries the burst power in the first slot that is found.

Return value

<BurstPower>

Power of the burst in dBm.

Example

```
FETC: BURS: PBUR?
```

Queries the burst power.

Characteristics

*RST value: -

SCPI: device-specific

FETCh: BURSt[:BTS]: PTOTal?

This command queries the RF channel power.

Return value

<ChannelPower>

Power of the signal in dBm.

Example

```
FETC: BURS: PTOT?
```

Queries the RF channel power.

Characteristics

*RST value: -
SCPI: device-specific

FETCh: BURSt[:BTS]: SLOUsed?

This command queries the currently analyzed slot number.

Return value

```
<SlotNumber>
```

Slot number with a value between 0 and 7.

Example

```
FETC: BURS: SLOT?
```

Queries the number of the currently analyzed slot.

Characteristics

*RST value: -
SCPI: device-specific

FETCh: BURSt[:BTS]: TRAFfic?

This command queries the traffic activity in the analyzed GSM frame.

Return value

```
<TrafficActivity>
```

Traffic activity in %.

Example

```
FETC: BURS: TRAF?
```

Queries the traffic activity.

Characteristics

*RST value: -
SCPI: device-specific

FETCh: BURSt[:BTS]: TSC?

This command queries the training sequence.

Return value

```
<Sequence>
```

Number of the training sequence (0 to 7).

Example

```
FETC: BURS: TSC?
```

Queries the training sequence.

Characteristics

*RST value: -

SCPI: device-specific

FETCh: BURSt[:MACCuracy]: ALL?

This command queries all global and modulation accuracy results.

Return value

Set of values for each result in the Result Summary.

```
<ChannelPower>,<BurstPower>,<FreqError>,<Modulation>,<BSIC>,<TrafficActivity>,<GMSKSlot#>,<PhaseError>,<MagError>,<8PSKSlot#>,<SlotEVM>
```

Example

```
FETC: BURS: ALL?
```

Queries the results in the Result Summary.

Characteristics

*RST value: -

SCPI: device-specific

FETCh: BURSt[:MACCuracy]: BPOWer: CURRent?

This command queries the burst power.

Return value

```
<BurstPower>
```

Burst power in dBm.

Example

```
FETC: BURS: BPOW: CURR?
```

Queries the burst power result.

Characteristics

*RST value: -

SCPI: device-specific

FETCh: BURSt[:MACCuracy]: CTOI: RMS: CURRent?

This command queries the C/I result.

Return value

```
<CI value>
```

Carrier to interference ratio in dB.

Example

```
FETC:BURS:CTOI:RMS:CRR?
```

Queries the C/I result.

Characteristics

*RST value: -

SCPI: device-specific

FETCh:BURSt[:MACCuracy][:EVM]:PEAK:CURRent?

This command queries the peak EVM of the analyzed time slot.

Note that the EVM is only calculated for slots with 8PSK modulation.

Return value

<EVM>

Peak EVM of the analyzed slot in %.

Example

```
FETC:BURS:PEAK:CRR?
```

Queries the peak EVM.

Characteristics

*RST value: -

SCPI: device-specific

FETCh:BURSt[:MACCuracy][:EVM]:SLOT:CURRent?

This command queries the EVM of the analyzed time slot.

Note that the EVM is only calculated for slots with 8PSK modulation.

Return value

<EVM>

EVM of the analyzed slot in %.

Example

```
FETC:BURS:SLOT:CRR?
```

Queries the EVM.

Characteristics

*RST value: -

SCPI: device-specific

FETCh:BURSt[:MACCuracy]:FREQuency:CURRent?

This command queries the carrier frequency error.

Return value

<FrequencyError>

Frequency error. The unit is either kHz or ppm, depending on

Example

```
FETC.BURS:FREQ:CURR?
```

Queries the frequency error.

Characteristics

*RST value: -
SCPI: device-specific

FETCh:BURSt[:MACCuracy]:IQOffset:CURRent?

This command queries the I/Q offset of the analyzed time slot.

Note that the I/Q offset is only calculated for slots with 8PSK modulation.

Return value

<Offset>
I/Q offset in dB.

Example

```
FETC:BURS:IQOF:CURR?
```

Queries the I/Q offset.

Characteristics

*RST value: -
SCPI: device-specific

FETCh:BURSt[:MACCuracy]:MERRor:RMS:CURRent?

This command queries the magnitude error of the analyzed time slot.

Note that the phase error is only calculated for slots with GMSK modulation.

Return value

<MagnitudeError>
Magnitude error in %.

Example

```
FETC:BURS:MERR:RMS:CURR?
```

Queries the magnitude error.

Characteristics

*RST value: -
SCPI: device-specific

FETCh:BURSt[:MACCuracy]:PERRor:RMS:CURRent?

This command queries the phase error of the analyzed time slot.

Note that the magnitude error is only calculated for slots with GMSK modulation.

Return value

<PhaseError>
Phase error in degree.

Example

FETC: BURS: PERR: RMS: CURR?
Queries the phase error.

Characteristics

*RST value: -
SCPI: device-specific

[SENSe:]BWIDth:OCCupied?

This command queries the occupied bandwidth as shown in the Spectrum Overview.

Return value

<Bandwidth>
Occupied bandwidth in Hz.

Example

BWID: OCC?
Queries the occupied bandwidth.

Characteristics

*RST value: -
SCPI: device-specific

TRACe[:DATA] <Trace>

This command queries the measurement results.

Parameter

TRACE1

Return value (for TRACE1)

The return values depend on the selected result display:

- Spectrum Overview and Burst Power

The R&S FSH returns 631 values. Each value corresponds to one pixel of the trace.

- Result Summary

The R&S FSH returns the contents of the Result Summary. The order of the values is as follows.

<ChannelPower>,<BurstPower>,<FreqError>,<Modulation>,
<BSIC>,<TrafficActivity>,<Slot#>,<PhaseError>,<MagError>

The command returns '1.#QNAN' if a result could not be calculated (e.g. if the channel search is off).

Characteristics

*RST value: -
SCPI: conform

7.7.1.11 Analyzing Measurement Results

These commands control various functions to analyze measurement results.

List of commands

- [UNIT:FERRor <Unit>](#) (p. 196)

UNIT:FERRor <Unit>

This command selects the unit for the frequency error.

Parameter

<Unit>
HZ | PPM

Example

```
UNIT:EVM HZ  
Frequency error is in Hz.
```

Characteristics

*RST value: -
SCPI: device-specific

7.7.2 Performing Measurements on 3GPP WCDMA Signals

When you perform measurements on 3GPP WCDMA signals, you can use the remote commands described in this chapter.



Availability of remote commands

Note that the listed remote commands take effect only if option R&S FSH-K44 is installed.

7.7.2.1 Setting the Frequency

The following commands configure the frequency axis (x-axis) of the active display.

The suffix <n> in the following commands is irrelevant.

List of commands

- [\[SENSe:\]CHANnel](#) (p. 89)
- [\[SENSe:\]FREQUency:CENTer<n> <Frequency>](#) (p. 37)
- [\[SENSe:\]FREQUency:CENTer:STEP](#) (p. 37)
- [\[SENSe:\]FREQUency:CENTer:STEP:LINK](#) (p. 38)
- [\[SENSe:\]FREQUency:INPut:MODE](#) (p. 38)

For a detailed description of the commands refer to "[Configuring the Horizontal Axis](#)" in spectrum analyzer mode.

7.7.2.2 Setting Amplitude Parameters

The following commands configure the level axis (y-axis) and level parameters of the active display.

The suffix <n> in the following commands is irrelevant.

List of commands

- [CALCulate:MARKer:FUNction:LEVel ONCE](#) (p. 183)
- [DISPlay\[:WINDow\]:TRACe<n>:Y\[:SCALe\]:RLEVel](#) (p. 43)
- [DISPlay\[:WINDow\]:TRACe<n>:Y\[:SCALe\]:RLEVel:OFFSet](#) (p. 44)
- [INPut<n>:ATTenuation <Attenuation>](#) (p. 44)
- [INPut<n>:ATTenuation:MODE](#) (p. 45)
- [INPut<n>:ATTenuation:AUTO](#) (p. 45)
- [INPut<n>:GAIN:STATe](#) (p. 46)

For a detailed description of commands not described below refer to "[Configuring the Vertical Axis](#)" in spectrum analyzer mode.

7.7.2.3 Setting the Bandwidths

The following commands configure the filter bandwidths of the R&S FSH. Note that both groups of commands (BANDwidth and BWIDth) are the same.

The suffix <n> in the following commands is irrelevant.

List of commands:

- [\[SENSe:\]BANDwidth|BWIDth<n>\[:RESolution\] <ResBW>](#) (p. 49)
- [\[SENSe:\]BANDwidth|BWIDth<n>\[:RESolution\]:AUTO <State>](#) (p. 49)

For a detailed description of commands refer to "[Setting the Bandwidths](#)" in spectrum analyzer mode.

7.7.2.4 Working with Traces

The following commands set up the trace and the various functions associated with it, e.g. the selection of the detector.

The suffix <n> in the following commands is irrelevant.

List of commands

- [DISPlay\[:WINDow\]:TRACe<n>:MEMory\[:STATe\] <State>](#) (p. 61)
- [DISPlay\[:WINDow\]:TRACe<n>:MODE <TraceMode>](#) (p. 62)
- [DISPlay\[:WINDow\]:TRACe<n>\[:STATe\] <State>](#) (p. 61)

For a detailed description of commands refer to "[Working with Traces](#)" in spectrum analyzer mode.

7.7.2.5 Performing and Triggering the Measurement

The following commands initialize a measurement and set up the sweep.

List of commands

- [*WAI](#) (p. 35)
- [ABORt](#) (p. 51)
- [INITiate\[:IMMediate\]](#) (p. 51)
- [INITiate:CONTInuous <SweepMode>](#) (p. 52)

For a detailed description of commands refer to "[Performing and Triggering Measurements](#)" in spectrum analyzer mode.

7.7.2.6 Using Markers

The following commands control markers. In the 3GPP application, markers are available in the spectrum overview and isotropic antenna result displays only.

The suffix <n> in the following commands is irrelevant.

The suffix <m> in the following commands selects the marker or deltamarker and is in the range from {1...6}.

List of commands

- [CALCulate<n>:DELTamarker<m>\[:STATe\] <State>](#) (p. 66)
- [CALCulate<n>:DELTamarker<m>:AOFF](#) (p. 67)
- [CALCulate<n>:DELTamarker<m>:MAXimum\[:PEAK\]](#) (p. 67)
- [CALCulate<n>:DELTamarker<m>:MAXimum:NEXT](#) (p. 67)
- [CALCulate<n>:DELTamarker<m>:MINimum\[:PEAK\]](#) (p. 68)
- [CALCulate<n>:DELTamarker<m>:X <Coordinate>](#) (p. 68)
- [CALCulate<n>:DELTamarker<m>:X:RELative <Distance>](#) (p. 69)
- [CALCulate<n>:MARKer<m>\[:STATe\] <State>](#) (p. 70)
- [CALCulate<n>:MARKer<m>:AOFF](#) (p. 70)
- [CALCulate<n>:MARKer<m>:MAXimum\[:PEAK\]](#) (p. 70)
- [CALCulate<n>:MARKer<m>:MAXimum:NEXT](#) (p. 71)
- [CALCulate<n>:MARKer<m>:MINimum\[:PEAK\]](#) (p. 71)
- [CALCulate<n>:MARKer<m>:X <Coordinate>](#) (p. 71)

For a detailed description of commands refer to "Using Markers" in spectrum analyzer mode.

7.7.2.7 Working with Channel Tables

Use the following commands to work with channel tables.

List of commands

- [\[SENSe:\]CHANnel:TABLE:SElect <ChannelTable>](#) (p. 89)

For a detailed description of commands refer to "Working with Channel Tables" in spectrum analyzer mode.

7.7.2.8 Selecting the Result Display

The following commands select the result display.

List of commands

- [CALCulate:FEED <ResultDisplay>](#) (p. 199)

CALCulate:FEED <ResultDisplay>

This command selects the result display.

Parameter

<ResultDisplay>

'STAT:LIMits'	Selects the Limit Check results.
'XPOWer:CPOWer'	Selects the Spectrum Overview.
'XPOWer:CDPOWer'	Selects the Code Domain Power results.

'XPOWer:IANtenna'	Selects the Isotropic Antenna results.
'XTIMe:CDPower:ERRor:SUMMary'	Selects the Result Summary.
'XTIMe:CDPower:ERRor:CTABle'	Selects the Code Domain Channel Table.
'XTIMe:CDPower:SCODes'	Selects the Scrambling Codes results.

Example

```
CALC:FEED 'XPOW:CPOW'
```

Selects the spectrum overview result display.

Characteristics

*RST value: 'XTIM:CDP:ERR:SUMM'

SCPI: device-specific

7.7.2.9 Configuring the Measurement

The following commands configure distance-to-fault measurements. To perform the actual measurement, use the commands described in section "[Performing and Triggering the Measurement](#)".

List of commands

- [\[SENSe:\]CDPower:ALENgtH <AnalysisLength>](#) (p. 200)
- [\[SENSe:\]CDPower:ANTenna <Antenna>](#) (p. 201)
- [\[SENSe:\]CDPower:CODE <Code>](#) (p. 201)
- [\[SENSe:\]CDPower:PREFereNce](#) (p. 202)
- [\[SENSe:\]CDPower:SLOT <Slot>](#) (p. 202)

[SENSe:]CDPower:ALENgtH <AnalysisLength>

This command selects the scope of the measurement.

Parameter

<AnalysisLength>

FRAMe	Analyzes a single slot.
SLOT	Analyzes a complete frame (15 slots).

Example

```
CDP:ALEN SLOT
```

Analyzes a single slot.

Characteristics

*RST value: SLOT

SCPI: device-specific

[SENSe:]CDPower:ANTenna <Antenna>

This command selects the antenna diversity for base station measurements with two antennas.

Parameters

<Antenna>

ALL	Synchronizes to both antennas.
ANT1	Synchronizes to antenna 1.
ANT2	Synchronizes to antenna 2.
OFF	Turns off antenna diversity for base stations with one antenna.

Example

CDP:ANT 2
Synchronizes to antenna 2.

Characteristics

*RST value: OFF
SCPI: device-specific

[SENSe:]CDPower:CODE <Code>

This command selects the code number.

Parameters

<Code>

Code number in the range from 0 to 511 (based on code class 9).

Example

CDP:CODE 3
Selects code 3.

Characteristics

*RST value: -
SCPI: device-specific

[SENSe:]CDPower:FEMRange <Range>

This command selects the scope of the frequency error.

Parameter

<AnalysisLength>

FRAMe	Calculates the frequency error over a frame.
SLOT	Calculates the frequency error over a slot.

Example

```
CDP:FEMR SLOT
```

Analyzes the frequency error over a single slot.

Characteristics

*RST value: SLOT

SCPI: device-specific

[SENSe:]CDPower:PREFerence <PowerMode>

This command defines whether the code power is an absolute value or a value related to the power of CPICH.

Parameters

<PowerMode>

ABSolute	Absolute code power.
CPICH	Code power relative to the CPICH

Example

```
CDP:PREF ABS
```

Displays the code power as absolute values.

Characteristics

*RST value: -

SCPI: device-specific

[SENSe:]CDPower:SLOT <Slot>

This command selects the slot of the P-CPICHs.

Parameters

<Slot>

Number of the slot in the range from 0 to 14.

Example

```
CDP:SLOT 3
```

Selects slot 3 for the P-CPICH.

Characteristics

*RST value: -

SCPI: device-specific

7.7.2.10 Determining Scrambling Codes

The following commands determine the scrambling codes for WCDMA measurements.

List of commands

- [\[SENSe:\]CDPower:LCODE:PRIMary](#) (p. 204)
- [\[SENSe:\]CDPower:LCODE:SEARch:AUTO <State>](#) (p. 204)
- [\[SENSe:\]CDPower:LCODE:SEARch\[:IMMediate\]](#) (p. 204)
- [\[SENSe:\]CDPower:LCODE:SEARch:LIST?](#) (p. 205)
- [\[SENSe:\]CDPower:LCODE:SEConDary](#) (p. 205)

[SENSe:]CDPower:LCODE:PRIMary <PrimScrambling>

This command sets the primary scrambling code of the base station used to demodulate the signal.

Parameters

<PrimScrambling>
numeric value in the range from 0 to 511

Example

```
CDP:LCOD:PRIM 211
```

Sets the primary scrambling code to 211.

Characteristics

*RST value: -
SCPI: device-specific

[SENSe:]CDPower:LCODE:SEARch:AUTO <State>

This command turns the automatic search for the scrambling code before each sweep on and off.

If successful, the R&S FSH returns the strongest scrambling code it has found and performs the code domain analysis on that code.

Parameters

<State>
ON | OFF

Example

```
CDP:LCOD:SEAR:AUTO ON
```

Turns on the automatic search for scrambling codes.

Characteristics

*RST value: ON
SCPI: device-specific

[SENSe:]CDPower:LCODE:SEARch[:IMMediate]

This command initiates a search for the scrambling code of the current signal. It is possible to detect multiple scrambling codes.

The search routine is able to find primary scrambling codes. Secondary scrambling codes are assumed to be 0. The command does not detect alternative scrambling codes.

The detection range is 0x0000 – 0x1FF0h with the last digit always being 0.

This command is an event and therefore has no *RST value and no query.

Example

```
CDP:LCOD:SEAR
```

Initiates a search for the scrambling code(s).

Characteristics

*RST value: -

SCPI: device-specific

[SENSe:]CDPower:LCODE:SEARch:LIST?

This command returns a list of scrambling codes that have been found during the automatic search.

Note that in order to get a valid list of codes, you have to force a search for scrambling codes with `[SENSe:]CDPower:LCODE:SEARch[:IMMEDIATE]`.

This command is a query and therefore has no default value.

Return values

The command returns three values for each scrambling code that has been found: <decimal scrambling code value>, <hexadecimal scrambling code value>, <power in dBm>, (...)

Note:

The return values are a combination of primary and secondary scrambling codes. The return value for primary code 1, scrambling code 0 would be, for example: 16x<primary code> + <secondary code> = 16 (dec) or 0x10 (hex).

Example

```
CDP:LCOD:SEAR:LIST?
```

```
16,0x10,-18.04,32,0x20,-22.87,48,0x30,-27.62,64,0x40,-29.46
```

Queries the found scrambling codes.

Characteristics

*RST value: -

SCPI: device-specific

[SENSe:]CDPower:LCODE:SECOndary <SecScrambling>

This command sets the secondary scrambling code of the base station used to demodulate the signal.

Parameters

<SecScrambling>

numeric value in the range from 0 to 15

Example

```
CDP:LCOD:SEC 8
```

Sets the secondary scrambling code to 8.

Characteristics

*RST value: -
SCPI: device-specific

7.7.2.11 Performing a Channel Search

The following commands control a channel search.

List of commands

- [\[SENSe:\]CDPower:CSEarch\[:STATe\] <State>](#) (p. 206)

[SENSe:]CDPower:CSEarch[:STATe] <State>

This command turns a channel search on and off.

The command takes effect only if you have selected the Result Summary result display. All other result displays automatically select the channel search state as required.

Parameters

<State>
ON | OFF

Example

```
CDP:CSE ON
```

Turns on the automatic channel search.

Characteristics

*RST value: ON
SCPI: device-specific

7.7.2.12 Using An Isotropic Antenna

This chapter describes all commands available to set up measurements with an isotropic antenna.

List of commands

- [INPut:ANTenna:MEASure <Direction>](#) (p. 117)
- [\[SENSe:\]CORRection:TRANsducer<c>:ISOTropic\[:STATe\]?](#) (p. 118)

7.7.2.13 Getting Measurement Results

The following commands retrieve the results of the current measurement.

The suffix <m> at MARKer is irrelevant.

List of commands

- [CALCulate:MARKer<m>:FUNCTION:WCDPower\[:BTS\]:RESult?](#) (p. 207)
- [\[SENSe:\]BWIDth:OCCupied?](#) (p. 195)
- [TRACe\[:DATA\] <Trace>](#) (p. 208)

CALCulate:MARKer<m>:FUNCTION:WCDPower[:BTS]:RESult? <Result>

This command queries the measurement results.

This command is a query and therefore has no *RST value.

Parameter

<Result>

ACHannels	Queries the number of active channels ¹⁾ .
ARCDerror	Queries the Average RCDE ¹⁾ .
CPECi0	Queries the Ec/Io value of the P-CPICH.
CPEVm	Queries the EVM of the P-CPICH.
CPPower	Queries the power of the P-CPICH.
FERRor	Queries the Carrier Frequency Error.
IQIMbalance	Queries the Gain Imbalance ¹⁾ .
IQOffset	Queries the I/Q Offset ¹⁾ .
ICPPower	Queries the power of the P-CPICH (x-, y- and z-direction and RMS value of all three) ³⁾ .
IPTotal	Queries the total power of the signal (x-, y- and z-direction and RMS value of all three) ³⁾ .
ISCFound	Queries the scrambling codes found (x-, y- and z-direction) ³⁾ .
MACCuracy	Queries the Composite EVM ¹⁾ .
PCDerror	Queries the Peak Code Domain Error ¹⁾ .
PCECi0	Queries the Ec/io value of the P-CCPCH.
PCEVm	Queries the EVM of the P-CCPCH.
PCPower	Queries the power of the P-CCPCH.
PSPower	Queries the power of the P-SCH.
PTOTAL	Queries the total power of the signal (RF channel power).
SCFound	Queries the scrambling code found ²⁾ .
SSPower	Queries the power of the S-SCH.

¹⁾ only if channel search is on

²⁾ only if automatic scrambling code search is on

³⁾ only for measurements with an isotropic antenna

Return value

One value for every parameter.

The unit depends on the result you have queried.

Example

```
CALC:MARK:FUNC:WCDP:RES PTOT
```

Queries the total power of the signal.

Characteristics

*RST value: -

SCPI: device-specific

TRACe[:DATA] <Trace>

This command queries the measurement results.

Parameter

CWCDp | TRACE1

Return value (for CWCDp)

The R&S FSH returns a set of values for each active code channel in ascending order.

<SpreadingFactor>,<CodeNumber>,<PowerAbs>,<PowerRel>,<TOffset>,
<CodeChannelPilotLength>,<ChannelState>,<ChannelType>,<Modulation>,
<Reserved>,...

CWCDp is available for the Channel Table and Code Domain Power result display.

Return value (for TRACE1)

The return values depend on the selected result display:

- Spectrum Overview and Isotropic Antenna

The R&S FSH returns 631 values. Each value corresponds to one pixel of the trace.

Scrambling Codes

The R&S FSH returns 3 values for every code found.

<decimal scrambling code value>, <hexadecimal scrambling code value>,
<power in dBm>,...

For more information see [\[SENSe:\]CDPower:LCODE:SEARCH:LIST?](#).

- Result Summary

The R&S FSH returns the contents of the Result Summary. The order of the values is as follows.

<TotalPower>,<CarrFreqError>,<CompositeEVM>,<PeakCDE>,<IQOffset>,
<IQImbalance>,<ActiveChannels>,<AverageRCDE>,<PowerCPICH>,
<EVMCPICH>,<PowerPCCPCH>,<EVMPCCPCH>,<PowerPSCH>,
<PowerSSCH>,<SCFound>

The command returns '1.#QNAN' if a result could not be calculated (e.g. if the channel search is off).

- Code Domain Power

The R&S FSH returns a set of values for each active code channel in ascending order.

<SpreadingFactor>,<CodeNumber>,<PowerAbs>,<PowerRel>,<TOffset>

- Code Domain Channel Table

The R&S FSH returns a set of values for each active code channel. The channels are sorted by their spreading factor and code number in ascending order. The first two results are always the P-SCH and the S-SCH.

<SpreadingFactor>,<CodeNumber>,<PowerAbs>,<PowerRel>,<TOffset>

A '-1' indicates that no result could be found (e.g. for SCH channels that are not spread and therefore don't have a spreading factor or code number).

For more information see "[Return Value Codes](#)" on page 210.

Characteristics

*RST value: -
SCPI: conform

7.7.2.14 Analyzing Measurement Results

These commands control various functions to analyze measurement results.

List of commands

- [UNIT:EVM <Unit>](#) (p. 209)
- [UNIT:FERRor <Unit>](#) (p. 210)

UNIT:EVM <Unit>

This command selects the unit for EVM values.

Parameter

<Unit>
DB | PCT

Example

UNIT:EVM DB
All EVM results are in dB.

Characteristics

*RST value: -
 SCPI: device-specific

UNIT:FERRor <Unit>

This command selects the unit for the frequency error.

Parameter

<Unit>
 HZ | PPM

Example

```
UNIT:EVM HZ
```

Frequency error is in Hz.

Characteristics

*RST value: -
 SCPI: device-specific

7.7.2.15 Return Value Codes

This chapter contains a list for encoded return values.

<ChannelType>

0	DPCH
1	PICH
2	C-PICH
3	P-SCH
4	S-SCH
5	P-CCPCH
6	S-CCPCH
7	HS-SCCH
8	HS-PDSCH
9	CHAN (unrecognized channel type)
10	CPRSD
11	CPR-TPC
12	CPR-SF/2
13	CPR-SF/2-TPC
14	EHICH-ERGCH
15	EAGCH
16	S-CPICH

<Channel State>

0	Inactive
1	Active

<Modulation>

2	QPSK
4	16QAM
5	64QAM
15	NONE

7.7.3 Performing Measurements on CDMA2000 Signals

When you perform measurements on CDMA2000 signals, you can use the remote commands described in this chapter.



Availability of remote commands

Note that the listed remote commands take effect only if option R&S FSH-K46(E) is installed.

7.7.3.1 Setting the Frequency

The following commands configure the frequency axis (x-axis) of the active display. The suffix <n> in the following commands is irrelevant.

List of commands

- [\[SENSe:\]CHANnel](#) (p. 89)
- [\[SENSe:\]FREQUency:CENTer<n> <Frequency>](#) (p. 37)
- [\[SENSe:\]FREQUency:CENTer:STEP](#) (p. 37)
- [\[SENSe:\]FREQUency:CENTer:STEP:LINK](#) (p. 38)
- [\[SENSe:\]FREQUency:MODE](#) (p. 39)
- [\[SENSe:\]FREQUency:SPAN<n>](#) (p. 40)
- [\[SENSe:\]FREQUency:SPAN<n>:AUTO <State>](#) (p. 40)
- [\[SENSe:\]FREQUency:STARt<n> <StartFrequency>](#) (p. 41)
(available as query only)
- [\[SENSe:\]FREQUency:STOP<n> <StopFrequency>](#) (p. 41)
(available as query only)

For a detailed description of the commands refer to "[Configuring the Horizontal Axis](#)" in spectrum analyzer mode.

7.7.3.2 Setting Amplitude Parameters

The following commands configure the vertical axis and level parameters of the active display.

The suffix <n> in the following commands is irrelevant.

List of commands

- [CALCulate:MARKer:FUNCTion:LEVel ONCE](#) (p. 183)
- [DISPlay\[:WINDow\]:TRACe<n>:Y\[:SCALe\]:RLEVel](#) (p. 43)
- [DISPlay\[:WINDow\]:TRACe<n>:Y\[:SCALe\]:RLEVel:OFFSet](#) (p. 44)
- [INPut<n>:ATTenuation <Attenuation>](#) (p. 44)
- [INPut<n>:ATTenuation:MODE](#) (p. 45)
- [INPut<n>:ATTenuation:AUTO](#) (p. 45)
- [INPut<n>:GAIN:STATe](#) (p. 46)
- [INPut:IMPedance](#) (p. 46) (available as query only)

For a detailed description of commands not described below refer to "[Configuring the Vertical Axis](#)" in spectrum analyzer mode.

7.7.3.3 Setting the Bandwidths

The following commands configure the filter bandwidths of the R&S FSH. Note that both groups of commands (BANDwidth and BWIDth) are the same.

The suffix <n> in the following commands is irrelevant.

List of commands:

- [\[SENSE:\]BANDwidth|BWIDth<n>\[:RESolution\] <ResBW>](#) (p. 49)
- [\[SENSE:\]BANDwidth|BWIDth<n>\[:RESolution\]:AUTO <State>](#) (p. 49)

For a detailed description of commands refer to "[Setting the Bandwidths](#)" in spectrum analyzer mode.

7.7.3.4 Working with Traces

The following commands set up the trace and the various functions associated with it, e.g. the selection of the detector.

The suffix <n> in the following commands is irrelevant.

List of commands

- [DISPlay\[:WINDow\]:TRACe<n>:MEMory\[:STATe\] <State>](#) (p. 61)
- [DISPlay\[:WINDow\]:TRACe<n>:MODE <TraceMode>](#) (p. 62)
- [DISPlay\[:WINDow\]:TRACe<n>\[:STATe\] <State>](#) (p. 61)

For a detailed description of commands refer to "[Working with Traces](#)" in spectrum analyzer mode.

7.7.3.5 Performing and Triggering the Measurement

The following commands initialize a measurement and set up the sweep.

List of commands

- [*WAI](#) (p. 35)
- [ABORt](#) (p. 51)
- [INITiate\[:IMMEDIATE\]](#) (p. 51)
- [INITiate:CONTinuous <SweepMode>](#) (p. 52)
- [TRIGger<n>\[:SEQUence\]:SLOPe <TriggerSlope>](#) (p. 58)
- [TRIGger\[:SEQUence\]:SOURce](#) (p. 214)

For a detailed description of commands refer to "[Performing and Triggering Measurements](#)" in spectrum analyzer mode.

TRIGger[:SEquence]:SOURce <TriggerSource>

This command sets the type of trigger the R&S FSH uses.

Parameter

<TriggerSource>

IMMEDIATE	Free Run
EXTernal	External trigger
GPSSync	GPS trigger

For more information see [TRIGger<n>\[:SEquence\]:SOURce <TriggerSource>](#) and the operating manual.

7.7.3.6 Using Markers

The following commands control markers. In the CDMA2000 application, markers are available in the spectrum overview and isotropic antenna only.

The suffix <n> in the following commands is irrelevant.

The suffix <m> in the following commands selects the marker or deltamarker and is in the range from {1...6}.

List of commands

- [CALCulate<n>:DELTAmarker<m>\[:STATE\] <State>](#) (p. 66)
- [CALCulate<n>:DELTAmarker<m>:AOFF](#) (p. 67)
- [CALCulate<n>:DELTAmarker<m>:MAXimum\[:PEAK\]](#) (p. 67)
- [CALCulate<n>:DELTAmarker<m>:MAXimum:NEXT](#) (p. 67)
- [CALCulate<n>:DELTAmarker<m>:MINimum\[:PEAK\]](#) (p. 68)
- [CALCulate<n>:DELTAmarker<m>:X <Coordinate>](#) (p. 68)
- [CALCulate<n>:DELTAmarker<m>:X:RELative <Distance>](#) (p. 69)
- [CALCulate<n>:MARKer<m>\[:STATE\] <State>](#) (p. 70)
- [CALCulate<n>:MARKer<m>:AOFF](#) (p. 70)
- [CALCulate<n>:MARKer<m>:MAXimum\[:PEAK\]](#) (p. 70)
- [CALCulate<n>:MARKer<m>:MAXimum:NEXT](#) (p. 71)
- [CALCulate<n>:MARKer<m>:MINimum\[:PEAK\]](#) (p. 71)
- [CALCulate<n>:MARKer<m>:X <Coordinate>](#) (p. 71)

For a detailed description of commands refer to "Using Markers" in spectrum analyzer mode.

7.7.3.7 Working with Channel Tables

Use the following commands to work with channel tables.

List of commands

- [\[SENSe:\]CHANnel:TABLE:SElect <ChannelTable>](#) (p. 89)

For a detailed description of commands refer to "[Working with Channel Tables](#)" in spectrum analyzer mode.

7.7.3.8 Selecting the Result Display

The following commands select the result display.

List of commands

- [CALCulate:FEED <ResultDisplay>](#) (p. 215)

CALCulate:FEED <ResultDisplay>

This command selects the result display.

Parameter

<ResultDisplay>

'XPOWer:CPOWer'	Selects the Spectrum Overview.
'XPOWer:CDPOWer'	Selects the Code Domain Power results.
'XPOWer:PNScan'	Selects the PN Scanner.
'XTIME:CDPOWer:ERRor:SUMMery'	Selects the Result Summary.
'XTIME:CDPOWer:ERRor:CTABLE'	Selects the Code Domain Channel Table.

Example

```
CALC:FEED 'XPOW:CPOW'
```

Selects the spectrum overview result display.

Characteristics

*RST value: 'XTIM:CDP:ERR:SUMM'

SCPI: device-specific

7.7.3.9 Configuring the Measurement

The following commands configure measurements on CDMA2000 signals.

List of commands

- [\[SENSe:\]CDPower:CODE <Code>](#) (p. 216)
- [\[SENSe:\]CDPower:ORDer <CodeOrder>](#) (p. 216)
- [\[SENSe:\]CDPower:PNOFFset <PNOFFset>](#) (p. 217)
- [\[SENSe:\]CDPower:PNOFFset:AUTO](#) (p. 217)
- [\[SENSe:\]CDPower:PREFErence <Reference>](#) (p. 217)
- [\[SENSe:\]CDPower:SFACTOR <SpreadingFactor>](#) (p. 218)
- [CALCulate<n>:MARKer<m>:FUNction:CPOWER:BANDwidth <Bandwidth>](#) (p. 95)
(available as query only)

[SENSe:]CDPower:CODE <Code>

This command selects a particular code.

Parameter

<Code>

Code number in the range from 0 to 63 or 127, depending on the spreading factor.

Example

```
CDP:CODE 10
Selects code number 10.
```

Characteristics

*RST value: 0
SCPI: device-specific

[SENSe:]CDPower:ORDer <CodeOrder>

This command selects the code order.

Parameter

<CodeOrder>

HADamard | BITReverse

Example

```
CDP:ORD BITR
Selects BitReverse code order.
```

Characteristics

*RST value: HADamard
SCPI: device-specific

[SENSe:]CDPower:PNOffset <PNOffset>

This command sets the PN offset of the base station.

Parameter

<PNOffset>
numeric value in the range from 0 to 511

Example

```
CDP:PNOF 100
Sets a PN offset of 100
```

Characteristics

*RST value: 0
SCPI: device-specific

[SENSe:]CDPower:PNOffset:AUTO

This command automatically determines the PN offset of the base station.

This command is an event and therefore has no *RST value and no query.

Example

```
CDP:PNOF:AUTO
Initializes a search for the PN offset.
```

Characteristics

*RST value: -
SCPI: device-specific

[SENSe:]CDPower:PREference <Reference>

This command selects the reference power for relative results.

Parameter

<Reference>

PICH	Results are relative to the power of the pilot channel.
TOTAL	Results are relative to the total power of the signal.

Example

```
CDP:REF TOT
Relative results are related to the total signal power.
```

Characteristics

*RST value: TOTAL
SCPI: device-specific

[SENSe:]CDPower:SFACtor <SpreadingFactor>

This command selects the spreading factor.

Parameter

<SpreadingFactor>

64 | 128

Example

CDP:SFAC 128

Selects a spreading factor of 128

Characteristics

*RST value: 64

SCPI: device-specific

7.7.3.10 Getting Measurement Results

The following commands read out measurement results of CDMA2000 measurements.

- [CALCulate:MARKer:FUNCTION:CDPower\[:BTS\]:RESult? <Result>](#) (p. 218)
- [CALCulate:MARKer:FUNCTION:PNScan:LIST?](#) (p. 219)
- [\[SENSe:\]BWIDth:OCCupied?](#) (p. 195)
- [TRACe\[:DATA\]?](#) (p. 219)

CALCulate:MARKer:FUNCTION:CDPower[:BTS]:RESult? <Result>

This command reads out results of the result summary.

Parameter

<Result>

ACTive	Queries the number of active channels.
FERPm	Queries the Carrier Frequency Error in ppm.
FERRor	Queries the Carrier Frequency Error in Hz.
MACCuracy	Queries the Composite EVM.
PNFound	Queries the PN that was found.
PAverage	Queries the Peak to Average level.
PTOTal	Queries the Total Power of the signal.
RHO	Queries Rho.
TAU	Queries Tau.

Return values

The return values are the results as displayed in result summary.

Example

```
CALC:MARK:FUNC:CDP:RES? RHO
```

Returns the result for Rho.

Characteristics

*RST value: -
SCPI: device-specific

CALCulate:MARKer:FUNcTion:PNsCan:LIST?

This command returns the results of the PN scanner.

This command is a query and therefore has no default value.

Return value

Returns two values for every PN that was found:
<PNOffset>,<PNOffsetPower>

PNOffset	PN offset.
PNOffsetPower	Power of the PN offset.

Example

```
CALC:MARK.FUNC:PNsC:LIST?
```

Queries the results of the PN scanner.

Characteristics

*RST value: -
SCPI: device-specific

TRACe[:DATA]?

This command queries the measurement results.

Parameter

TRACE1 | CDCTable

Return value (for CDCTable)

The R&S FSH returns a set of values for each active code channel in ascending order.

```
<ChannelType>,<CodeClass>,<CodeNumber>,<RadioConfiguration>,  
<PowerAbs>,<PowerRel>,<SymbolRate>,<Reserved>,<Reserved>,...
```

```
<SpreadingFactor>,<CodeNumber>,<PowerAbs>,<PowerRel>,<TOffset>,  
<CodeChannelPilotLength>,<ChannelState>,<ChannelType>,<Modulation>,  
<Reserved>,...
```

For the two <Reserved> values, the command always returns '9'.

CDCTable is available for the Channel Table result display.

Return value (for TRACE1)

The return values depend on the selected result display:

- Spectrum overview

The R&S FSH returns 631 values. Each value corresponds to one pixel of the trace.

- Result Summary

The R&S FSH returns the contents of the Result Summary in the following order.

<TotalPower>,<Rho>,<ActiveChannels>,<CompositeEVM>,<PeakToAverage>,<Tau>,<CarrFreqError>,<PilotPower>,<PilotPowerRelToTotal>,<SyncPower>,<SyncPowerRelToTotal>,<SyncPowerRelToPilot>,<PilotPowerRelToPilot>,<PNFound>

- Code Domain Power

The R&S FSH returns three values for all active codes.

<CodeClass>,<CodeNumber>,<CodePower>,...

- Code Domain Channel Table

The R&S FSH returns five values for all active channels.

<ChannelType>,<CodeClass>,<CodeNumber>,<RadioConfiguration>,<AbsolutePower>,<RelativePower>,<Reserved>,<Reserved>,...

For the two <Reserved> values, the command always returns '9'.

For more information see "[Return Value Codes](#)" on page 220.

Characteristics

*RST value: -
SCPI: conform

7.7.3.11 Return Value Codes

This chapter contains a list for encoded return values.

<RadioConfiguration>

0	no radio configuration detected
1	radio configuration 1 - 2
2	radio configuration 3 - 5

7.7.4 Performing Measurements on 1xEV-DO Signals

When you perform measurements on 1xEV-DO signals, you can use the remote commands described in this chapter.



Availability of remote commands

Note that the listed remote commands take effect only if option R&S FSH-K47 is installed.

7.7.4.1 Setting the Frequency

The following commands configure the frequency axis (x-axis) of the active display.

The suffix <n> in the following commands is irrelevant.

List of commands

- [\[SENSe:\]CHANnel](#) (p. 89)
- [\[SENSe:\]FREQUency:CENTer<n> <Frequency>](#) (p. 37)
- [\[SENSe:\]FREQUency:CENTer:STEP](#) (p. 37)
- [\[SENSe:\]FREQUency:INPut:MODE](#) (p. 38)
- [\[SENSe:\]FREQUency:SPAN<n>](#) (p. 40)
- [\[SENSe:\]FREQUency:SPAN<n>:AUTO <State>](#) (p. 40)
- [\[SENSe:\]FREQUency:STARt<n> <StartFrequency>](#) (p. 41)
(available as query only)
- [\[SENSe:\]FREQUency:STOP<n> <StopFrequency>](#) (p. 41)
(available as query only)

For a detailed description of the commands refer to "[Configuring the Horizontal Axis](#)" in spectrum analyzer mode.

7.7.4.2 Setting Amplitude Parameters

The following commands configure the vertical axis and level parameters of the active display.

List of commands

- [CALCulate:MARKer:FUNCTion:LEVEl ONCE](#) (p. 183)
- [DISPlay\[:WINDow\]:TRACe<n>:Y\[:SCALe\]:RLEVEl](#) (p. 43)
- [DISPlay\[:WINDow\]:TRACe<n>:Y\[:SCALe\]:RLEVEl:OFFSet](#) (p. 44)
- [INPut<n>:ATTenuation <Attenuation>](#) (p. 44)
- [INPut<n>:ATTenuation:MODE](#) (p. 45)
- [INPut<n>:ATTenuation:AUTO](#) (p. 45)
- [INPut<n>:GAIN:STATe](#) (p. 46)
- [INPut:IMPedance](#) (p. 46) (available as query only)

For a detailed description of commands not described below refer to "[Configuring the Vertical Axis](#)" in spectrum analyzer mode.

7.7.4.3 Setting the Bandwidths

The following commands configure the filter bandwidths of the R&S FSH. Note that both groups of commands (BANDwidth and BWIDth) are the same.

The suffix <n> in the following commands is irrelevant.

List of commands:

- [\[SENSe:\]BANDwidth|BWIDth<n>\[:RESolution\] <ResBW>](#) (p. 49)
(available as query only)
- [\[SENSe:\]BANDwidth|BWIDth<n>\[:RESolution\]:AUTO <State>](#) (p. 49)

For a detailed description of commands refer to "[Setting the Bandwidths](#)" in spectrum analyzer mode.

7.7.4.4 Working with Traces

The following commands set up the trace and the various functions associated with it, e.g. the selection of the detector.

The suffix <n> in the following commands is irrelevant.

List of commands

- [DISPlay\[:WINDow\]:TRACe<n>:MEMory\[:STATe\] <State>](#) (p. 61)
- [DISPlay\[:WINDow\]:TRACe<n>:MODE <TraceMode>](#) (p. 62)
- [DISPlay\[:WINDow\]:TRACe<n>\[:STATe\] <State>](#) (p. 61)

For a detailed description of commands refer to "[Working with Traces](#)" in spectrum analyzer mode.

7.7.4.5 Performing and Triggering the Measurement

The following commands initialize a measurement and set up the sweep.

List of commands

- [*WAI](#) (p. 35)
- [ABORt](#) (p. 51)
- [INITiate\[:IMMediate\]](#) (p. 51)
- [INITiate:CONTinuous <SweepMode>](#) (p. 52)
- [TRIGger<n>\[:SEQuence\]:SLOPe <TriggerSlope>](#) (p. 58)
- [TRIGger\[:SEQuence\]:SOURce](#) (p. 214)

For a detailed description of commands refer to "[Performing and Triggering Measurements](#)" in spectrum analyzer mode.

TRIGger[:SEQuence]:SOURce <TriggerSource>

This command sets the type of trigger the R&S FSH uses.

Parameter

<TriggerSource>

IMMediate	Free Run
EXTernal	External trigger
GPSSync	GPS trigger

For more information see `TRIGger<n>[:SEquence]:SOURce <TriggerSource>` and the operating manual.

7.7.4.6 Using Markers

The following commands control markers. In the 1xEV-DO application, markers are available in the spectrum overview only.

For a detailed description of commands refer to "Using Markers" in spectrum analyzer mode.

The suffix <n> in the following commands is irrelevant.

The suffix <m> in the following commands selects the marker or deltamarker and is in the range from {1...6}.

List of commands

- `CALCulate<n>:DELTamarker<m>[:STATe] <State>` (p. 66)
- `CALCulate<n>:DELTamarker<m>:AOFF` (p. 67)
- `CALCulate<n>:DELTamarker<m>:MAXimum[:PEAK]` (p. 67)
- `CALCulate<n>:DELTamarker<m>:MAXimum:NEXT` (p. 67)
- `CALCulate<n>:DELTamarker<m>:MINimum[:PEAK]` (p. 68)
- `CALCulate<n>:DELTamarker<m>:X <Coordinate>` (p. 68)
- `CALCulate<n>:DELTamarker<m>:X:RELative <Distance>` (p. 69)
- `CALCulate<n>:MARKer<m>[:STATe] <State>` (p. 70)
- `CALCulate<n>:MARKer<m>:AOFF` (p. 70)
- `CALCulate<n>:MARKer<m>:MAXimum[:PEAK]` (p. 70)
- `CALCulate<n>:MARKer<m>:MAXimum:NEXT` (p. 71)
- `CALCulate<n>:MARKer<m>:MINimum[:PEAK]` (p. 71)
- `CALCulate<n>:MARKer<m>:X <Coordinate>` (p. 71)

For a detailed description of commands refer to "Using Markers" in spectrum analyzer mode.

7.7.4.7 Working with Channel Tables

Use the following commands to work with channel tables.

List of commands

- `[SENSe:]CHANnel:TABLE:SElect <ChannelTable>` (p. 89)

For a detailed description of commands refer to "Working with Channel Tables" in spectrum analyzer mode.

7.7.4.8 Selecting the Result Display

Use the following commands to select the result display.

List of commands

- [CALCulate:FEED <ResultDisplay>](#) (p. 225)

CALCulate:FEED <ResultDisplay>

This command selects the result display.

Parameter

<ResultDisplay>

'XPOWer:CPOWer'	Selects the Spectrum Overview.
'XPOWer:BURSt'	Selects the Burst Power results.
'XPOWer:PNSCan'	Selects the PN Scanner.
'XTIMe:CDPower:ERRor:SUMMary'	Selects the Result Summary.

Example

```
CALC:FEED 'XPOW:CPOW'
```

Selects the spectrum overview result display.

Characteristics

*RST value: 'XTIM:CDP:ERR:SUMM'

SCPI: device-specific

7.7.4.9 Configuring the Measurement

The following commands configure measurements on 1xEV-DO signals.

List of commands

- [\[SENSe:\]CDPower:PNOFfset <PNOFset>](#) (p. 225)
- [\[SENSe:\]CDPower:PNOFfset:AUTO <PNOFset>](#) (p. 226)
- [\[SENSe:\]CDPower:PREFerence <Reference>](#) (p. 226)

[SENSe:]CDPower:PNOFfset <PNOFset>

This command sets the PN offset of the base station.

Parameter

<PNOFset>

numeric value in the range from 0 to 511

Example

```
CDP:PNOF 100
```

Sets a PN offset of 100

Characteristics

*RST value: 0
 SCPI: device-specific

[SENSe:]CDPower:PNOFfset:AUTO <PNOFset>

This command automatically determines the PN offset of the base station.

This command is an event and therefore has no *RST value and no query.

Example

CDP:PNOF:AUTO
 Initializes a search for the PN offset.

Characteristics

*RST value: -
 SCPI: device-specific

[SENSe:]CDPower:PREFerence <Reference>

This command selects the reference power for relative results.

Parameter

<Reference>

PICH	Results are relative to the power of the pilot channel.
TOTAL	Results are relative to the total power of the signal.

Example

CDP:PREF:TOT
 Relative results are related to the total signal power.

Characteristics

*RST value: TOTAL
 SCPI: device-specific

7.7.4.10 Getting Measurement Results

The following commands read out measurement results of 1xEV-DO measurements.

- [CALCulate:MARKer:FUNction:CDPower\[:BTS\]:RESult? <Result>](#) (p. 227)
- [CALCulate:MARKer:FUNction:PNScan:LIST?](#) (p. 227)
- [\[SENSe:\]BWIDth:OCCupied?](#) (p. 195)
- [TRACe:DATA?](#) (p. 228)

CALCulate:MARKer:FUNCtion:CDPower[:BTS]:RESult? <Result>

This command reads out results of the result summary.

Parameter

<Result>

EVMPIlot	Queries the EVM of the pilot channel in %.
FERRor	Queries the Carrier Frequency Error in Hz.
FERPpm	Queries the Carrier Frequency Error in ppm.
PNFound	Queries the PN that was found.
PAverage	Queries the Peak to Average level.
PDATA	Queries the power of the pilot channel.
PMAC	Queries the power of the MAC channel.
PPILot	Queries the power of the data channel.
PTOTal	Queries the Total Power of the signal.
RHOPilot	Queries Rho.
TACTivity	Queries the traffic activity in %.
TAU	Queries Tau.

Return values

The return values are the results as displayed in result summary.

Example

```
CALC:MARK:FUNC:CDP:RES? RHOP
```

Returns the result for Rho.

Characteristics

*RST value: -

SCPI: device-specific

CALCulate:MARKer:FUNCtion:PNScan:LIST?

This command queries the results of the PN scanner.

This command is a query and therefore has no default value.

Return value

Returns two values for every PN that was found:

<PNOffset>,<PNOffsetPower>

<PNOffset>	PN Offset
<PNOffsetPower>	Power of the PN Offset.

Example

```
CALC:MARK:FUNC:PNSC:LIST?
```

Queries the results of the PN scanner.

Characteristics

*RST value: -
SCPI: device-specific

TRACe:DATA?

This command queries the measurement results.

Return value

The return values depend on the selected result display:

- Spectrum Overview

The R&S FSH returns 631 values. Each value corresponds to one pixel of the trace.

- Result Summary

The R&S FSH returns the contents of the Result Summary in the following order.

```
<TotalPower>,<PeakToAverage>,<CarrFreqError>,<PNFound>,<Tau>,  
<Traffic>,<PilotPower>,<PilotPowerRelToTotal>,<PilotPowerRelToPilot>,  
<EVM>,<Rho>,<MACPower>,<MACPowerRelToTotal>,  
<MACPowerRelToPilot>,<DataPower>,<DataPowerRelToTotal>,  
<DataPowerRelToPilot>
```

Characteristics

*RST value: -
SCPI: conform

7.7.5 Performing Measurements on TD-SCDMA Signals

When you perform measurements on TD-SCDMA signals, you can use the remote commands described in this chapter.



Availability of remote commands

Note that the listed remote commands take effect only if option R&S FSH-K48 is installed.

7.7.5.1 Setting the Frequency

The following commands configure the frequency axis (x-axis) of the active display. The suffix <n> in the following commands is irrelevant.

List of commands

- [\[SENSe:\]CHANnel](#) (p. 89)
- [\[SENSe:\]FREQUency:CENTer<n> <Frequency>](#) (p. 37)
- [\[SENSe:\]FREQUency:CENTer:STEP](#) (p. 37)
- [\[SENSe:\]FREQUency:INPut:MODE](#) (p. 38)
- [\[SENSe:\]FREQUency:SPAN<n>](#) (p. 40)
- [\[SENSe:\]FREQUency:SPAN<n>:AUTO <State>](#) (p. 40)
- [\[SENSe:\]FREQUency:STARt<n> <StartFrequency>](#) (p. 41)
(available as query only)
- [\[SENSe:\]FREQUency:STOP<n> <StopFrequency>](#) (p. 41)
(available as query only)

For a detailed description of the commands refer to "[Configuring the Horizontal Axis](#)" in spectrum analyzer mode.

7.7.5.2 Setting Amplitude Parameters

The following commands configure the vertical axis and level parameters of the active display.

The suffix <n> in the following commands is irrelevant.

List of commands

- [CALCulate:MARKer:FUNCTion:LEVel ONCE](#) (p. 183)
- [DISPlay\[:WINDow\]:TRACe<n>:Y\[:SCALe\]:RLEVel](#) (p. 43)
- [DISPlay\[:WINDow\]:TRACe<n>:Y\[:SCALe\]:RLEVel:OFFSet](#) (p. 44)
- [INPut<n>:ATTenuation <Attenuation>](#) (p. 44)
- [INPut<n>:ATTenuation:MODE](#) (p. 45)
- [INPut<n>:ATTenuation:AUTO](#) (p. 45)
- [INPut<n>:GAIN:STATe](#) (p. 46)
- [INPut:IMPedance](#) (p. 46) (available as query only)

- [\[SENSe:\]CORRection:TRANsducer<c>:SELEct <TransducerFactor>](#) (p. 47)
- [\[SENSe:\]CORRection:TRANsducer<c>\[:STATe\] <State>](#) (p. 46)

For a detailed description of commands not described below refer to "[Configuring the Vertical Axis](#)" in spectrum analyzer mode.

7.7.5.3 Setting the Bandwidths

The following commands configure the filter bandwidths of the R&S FSH. Note that both groups of commands (BANDwidth and BWIDth) are the same.

The suffix <n> in the following commands is irrelevant.

List of commands:

- [\[SENSe:\]BANDwidth|BWIDth<n>\[:RESolution\] <ResBW>](#) (p. 49)
(available as query only)
- [\[SENSe:\]BANDwidth|BWIDth<n>\[:RESolution\]:AUTO <State>](#) (p. 49)

For a detailed description of commands refer to "[Setting the Bandwidths](#)" in spectrum analyzer mode.

7.7.5.4 Working with Traces

The following commands set up the trace and the various functions associated with it, e.g. the selection of the detector.

The suffix <n> in the following commands is irrelevant.

List of commands

- [DISPlay\[:WINDow\]:TRACe<n>:MEMory\[:STATe\] <State>](#) (p. 61)
- [DISPlay\[:WINDow\]:TRACe<n>:MODE <TraceMode>](#) (p. 62)
- [DISPlay\[:WINDow\]:TRACe<n>\[:STATe\] <State>](#) (p. 61)

For a detailed description of commands refer to "[Working with Traces](#)" in spectrum analyzer mode.

7.7.5.5 Performing and Triggering the Measurement

The following commands initialize a measurement and set up the sweep.

List of commands

- [*WAI](#) (p. 35)
- [ABORt](#) (p. 51)
- [INITiate\[:IMMEDIATE\] <SweepMode>](#) (p. 51)
- [INITiate:CONTInuous <SweepMode>](#) (p. 52)

For a detailed description of commands refer to "[Performing and Triggering Measurements](#)" in spectrum analyzer mode.

7.7.5.6 Using Markers

The following commands control markers. In the TD-SCDMA application, markers are available in the spectrum overview only.

The suffix <n> in the following commands is irrelevant.

The suffix <m> in the following commands selects the marker or deltamarker and is in the range from {1...6}.

List of commands

- [CALCulate<n>:DELTamarker<m>\[:STATe\] <State>](#) (p. 66)
- [CALCulate<n>:DELTamarker<m>:AOFF](#) (p. 67)
- [CALCulate<n>:DELTamarker<m>:MAXimum\[:PEAK\]](#) (p. 67)
- [CALCulate<n>:DELTamarker<m>:MAXimum:NEXT](#) (p. 67)
- [CALCulate<n>:DELTamarker<m>:MINimum\[:PEAK\]](#) (p. 68)
- [CALCulate<n>:DELTamarker<m>:X <Coordinate>](#) (p. 68)
- [CALCulate<n>:DELTamarker<m>:X:RELative <Distance>](#) (p. 69)
- [CALCulate<n>:MARKer<m>\[:STATe\] <State>](#) (p. 70)
- [CALCulate<n>:MARKer<m>:AOFF](#) (p. 70)
- [CALCulate<n>:MARKer<m>:MAXimum\[:PEAK\]](#) (p. 70)
- [CALCulate<n>:MARKer<m>:MAXimum:NEXT](#) (p. 71)
- [CALCulate<n>:MARKer<m>:MINimum\[:PEAK\]](#) (p. 71)
- [CALCulate<n>:MARKer<m>:X <Coordinate>](#) (p. 71)

For a detailed description of commands refer to "[Using Markers](#)" in spectrum analyzer mode.

7.7.5.7 Working with Channel Tables

Use the following commands to work with channel tables.

List of commands

- [\[SENSe:\]CHANnel:TABLE:SElect <ChannelTable>](#) (p. 89)

For a detailed description of commands refer to "[Working with Channel Tables](#)" in spectrum analyzer mode.

7.7.5.8 Selecting the Result Display

The following commands select the result display.

List of commands

- [CALCulate:FEED <ResultDisplay>](#) (p. 231)

CALCulate:FEED <ResultDisplay>

This command selects the result display.

Parameter

<ResultDisplay>

'XTIME:CDPower:ABSolute'	Selects the Code Domain Power (Absolute) results.
'XTIME:CDPower:RATio'	Selects the Code Domain Power (Relative) results.
'XTIME:CDPower:ERRor:SUMMary'	Selects the Result Summary.
'XTIME:CDPower:ERRor:CTABLE'	Selects the Channel Table.
'XTIME:CDPower:IDSCan'	Selects the Sync ID results.
'XPOWer:CPOWer'	Selects the Spectrum Overview.
'XPOWer:TPOWer'	Selects the Time Domain Power results.
'STATistics:LIMits'	Selects the Limit Check results.

Example

```
CALC:FEED 'XPOW:CPOW'
```

Selects the spectrum overview result display.

Characteristics

*RST value: 'XTIM:CDP:ERR:SUMM'

SCPI: device-specific

7.7.5.9 Configuring the Measurement

The following commands configure measurements on TD-SCDMA signals.

List of commands

- [\[SENSe:\]CDPower:MSHift <Shifts>](#) (p. 232)
- [\[SENSe:\]CDPower:MSHift:AUTO <State>](#) (p. 233)
- [\[SENSe:\]CDPower:PHASes <PhaseType>](#) (p. 233)
- [\[SENSe:\]CDPower:PREFerence <Reference>](#) (p. 233)
- [\[SENSe:\]CDPower:PSWitch <SwitchPoint>](#) (p. 234)
- [\[SENSe:\]CDPower:SCODE <ScramblingCode>](#) (p. 234)
- [\[SENSe:\]CDPower:SCODE:SEARch:AUTO <State>](#) (p. 235)
- [\[SENSe:\]CDPower:CSEarch\[:STATe\] <State>](#) (p. 235)
- [\[SENSe:\]CDPower:SLOT <Slot>](#) (p. 235)
- [UNIT:EVM <Unit>](#) (p. 236)
- [UNIT:FERRor >Unit>](#) (p. 236)

[SENSe:]CDPower:MSHift <Shifts>

This command defines the number of midamble shifts.

Parameter

<Shifts>

2 | 4 | 6 | 8 | 10 | 12 | 14 | 16

Example

CDP:MSH 8
 Defines 8 midamble shifts.

Characteristics

*RST value: 16
 SCPI: device-specific

[SENSe:]CDPower:MSHift:AUTO <State>

This command turns automatic detection of the maximum midamble shifts (users) on and off.

Parameter

<State>
 ON | OFF

Example

CDP:MSH:AUTO ON
 Turns automatic detection of the midamble shifts on.

Characteristics

*RST value: OFF
 SCPI: device-specific

[SENSe:]CDPower:PHASes <PhaseType>

This command selects the code channel phase.

Parameter

<PhaseType>

COMMon	Common phase.
MIDamble	Phase according to midamble.

Example

CDP:PHAS COMM
 Selects the common phase.

Characteristics

*RST value: COMMOn
 SCPI: device-specific

[SENSe:]CDPower:PREFerence <Reference>

This command selects the reference power for relative results.

Parameter

<Reference>

ABSolute	Power results are absolute values.
RELative	Power results are relative to the RF channel power.

Example

CDP: PReF ABS
 Selects the display of absolute results.

Characteristics

*RST value: ABSolute
 SCPI: device-specific

[SENSe:]CDPower:PSWitch <SwitchPoint>

This command defines the switching point between uplink and downlink.

Parameter

<SwitchPoint>
 Number of the slot in the TD-SCDMA subframe that serves as the switching point.
 The range is from 0 to 7.

Example

CDP: PSW 3
 Defines slot 3 as the switching point.

Characteristics

*RST value: 6
 SCPI: device-specific

[SENSe:]CDPower:SCODE <ScramblingCode>

This command defines the scrambling code of the base station.

Parameter

<ScramblingCode>
 Numeric value in the range from 0 to 127.

Example

CDP: PSW 10
 Defines the scrambling code 10.

Characteristics

*RST value: 0
 SCPI: device-specific

[SENSe:]CDPower:SCODE:SEARch:AUTO <State>

This command turns automatic detection of the scrambling code on and off.

If on, the R&S FSH looks for the strongest scrambling code it can find and shows it in the results.

Parameter

<State>
ON | OFF

Example

```
CDP:SCOD:SEAR:AUTO ON
```

Turns automatic scrambling code detection on.

Characteristics

*RST value: OFF
SCPI: device-specific

[SENSe:]CDPower:CSEarch[:STATE] <State>

This command turns the channel search on and off.

Note that the channel search is turned on by default for all result displays except the Result Summary.

Parameter

<State>
ON | OFF

Example

```
CDP:CSE ON
```

Turns the channel search on.

Characteristics

*RST value: OFF
SCPI: device-specific

[SENSe:]CDPower:SLOT <Slot>

This command selects the slot to be analyzed.

Parameter

<Slot>
Numeric value in the range from 0 to 6.

Note that you can only select slots used for the downlink. The availability depends on the location of the switching point.

Example

```
CDP:SLOT 2
```

Selects slot number 2.

Characteristics

*RST value: 0
 SCPI: device-specific

UNIT:EVM <Unit>

This command selects the unit for the EVM results.

Parameter

<Unit>
 DB | PCT

Characteristics

*RST value: OFF
 SCPI: device-specific

UNIT:FERRor >Unit>

This command selects the unit for the frequency error results.

Parameters

<Unit>
 HZ | PPM

Example

UNIT:FERR HZ
 Selects the unit Hz for the frequency error results.

Characteristics

*RST value: OFF
 SCPI: device-specific

7.7.5.10 Getting Measurement Results

The following commands read out measurement results of TD-SCDMA measurements.

List of commands

- [CALCulate:MARKer<m>:FUNction:CDPower\[:BTS\]:RESult? <Result>](#) (p. 236)
- [\[SENSe:\]BWIDth:OCCupied?](#) (p. 195)
- [TRACe:DATA <Trace>](#) (p. 238)

CALCulate:MARKer<m>:FUNction:CDPower[:BTS]:RESult? <Result>

This command queries the measurement results.

This command is a query and therefore has no *RST value.

Parameter

<Result>

ACHannels ¹	Queries the number of active channels.
ARCDerror ¹	Queries the Average RCDE (16QAM) in dB.
CEVM ¹	Queries the Composite EVM.
DPEV ²	Queries the EVM of the DwPTS.
DPPower ²	Queries the power of the DwPTS.
FERRor ⁰	Queries the Carrier Frequency Error.
IQOffset ¹	Queries the I/Q Offset.
IQIMbalance ¹	Queries the I/Q Imbalance.
OBWidth ³	Queries the Occupied Bandwidth.
PCDerror ¹	Queries the Peak Code Domain Error.
PCEV ⁰	Queries the EVM of the P-CCPCH (slot 0).
PD1 ⁰	Queries the power of the Data 1 part in a slot.
PD2 ⁰	Queries the power of the Data 2 part in a slot.
PDATa ⁰	Queries the power of both data parts in a slot.
PISPan ³	Queries the power in the current span.
PMIDamble ⁰	Queries the power of the midamble part in a slot.
PTOTAL ⁰	Queries the Total Power of the signal (RF Channel Power)
SCFound ¹	Queries the scrambling code.
SCI ²	Queries the C/I of the analyzed slots (six values) <CISlot0>,<CISlot1>,...,<CISlot6>
SEVM ²	Queries the EVM of the analyzed slots (six values) <EVMSlot0>,<EVMSlot1>,...,<EVMSlot6>
SPOWer ²	Queries the power of the analyzed slots (six values) <PowerSlot0>,<PowerSlot1>,...,<PowerSlot6>
UPPower ²	Queries the power of the UpPTS.

⁰ available for the Result Summary and the Code Domain Power

¹ available for the Result Summary if channel search is on and the Code Domain Power

² available for the Time Domain Power

³ available for the Spectrum Overview

Return value

One value for every parameter.

The unit depends on the result you have queried.

Example

```
CALC:MARK:FUNC:CDP:RES PTOT
```

Queries the total power of the signal.

Characteristics

*RST value: -

SCPI: device-specific

TRACe:DATA <Trace>

This command queries the measurement results.

Parameter

TRACE1

Return value (for TRACE1)

The return values depend on the selected result display:

- Spectrum Overview

The R&S FSH returns 631 values. Each value corresponds to one pixel of the trace.

- Result Summary

The R&S FSH returns the contents of the Result Summary. The order of the values is as follows.

```
<TotalPower>,<CarrFreqError>,<PCCPCH_EVM>,<DataPower>,<Data1Power>,<Data2Power>,<MidamblePower>,<CompositeEVM>,<PCDE>,<AvgRCDE>,<IQOffset>,<Imbalance>,<ScramblingCode>,<#ofChannels>
```

The command returns '-200' if a result could not be calculated (e.g. if the channel search is off).

- Code Domain Power

The R&S FSH returns three values for each code channel, whether active or not, in ascending order.

```
<CodeNumber>,<AbsPower>,<RelPower>,...
```

Relative power levels are relative to the RF channel power

- Code Domain Channel Table

The R&S FSH returns six values for each channel.

```
<CodeNumber>,<ChannelState>,<Modulation>,<SymbolEVM>,<AbsolutePower>,<RelativePower>,...
```

Relative power levels are relative to the RF channel power. The unit of the EVM results is either dB or %, depending on your selection.

For more information see [Return Value Codes](#) on page 239.

- Sync ID

The R&S FSH returns three values for each synchronization ID. The maximum number of simultaneously evaluated synchronization IDs is 7.

<ScramblingCode>,<Power>,<Delay>,...

The scrambling code is a decimal value. The power is an absolute value in dBm. The delay is the delay time ns. The delay of the first code is 0 s by definition.

- Time Domain Power

The R&S FSH returns 631 values. Each value corresponds to one pixel of the trace.

7.7.5.11 Return Value Codes

This chapter contains a list for encoded return values.

<CodeNumber>

Value in the range from 1 to 16.

<ChannelState>

0	inactive channel
1	active channel

<Modulation>

2	QPSK
3	8PSK
4	16QAM
5	64QAM
15	n/a; modulation type could not be detected

7.7.6 Performing Measurements on LTE Signals

When you perform measurements on LTE signals, you can use the remote commands described in this chapter.



Availability of remote commands

Note that the listed remote commands take effect only if options R&S FSH-K50 or -K51 are installed.

7.7.6.1 Setting the Frequency

The following commands configure the frequency axis (x-axis) of the active display.

The suffix <cc> selects the component carrier. The range is 1 to 5.

List of commands

- [\[SENSe\]:CHANnel<cc> <ChannelNumber>](#) (p. 240)
- [\[SENSe\]:CHANnel:TABLE:SElect<cc> <ChannelTable>](#) (p. 240)
- [\[SENSe\]:FREQUENCY:CENTer<cc> <Frequency>](#) (p. 241)
- [\[SENSe\]:FREQUENCY:INPut:MODE<cc> <InputMode>](#) (p. 241)

For a detailed description of the commands refer to "[Configuring the Horizontal Axis](#)" in spectrum analyzer mode.

[SENSe]:CHANnel<cc> <ChannelNumber>

This command selects the channel to be analyzed.

For more information see "[Working with Channel Tables](#)" on page 88.

Parameter

<ChannelNumber>

Numeric value that selects the number of the channel to be analyzed.

Characteristics

*RST value: depends on the channel table

SCPI: conform

[SENSe]:CHANnel:TABLE:SElect<cc> <ChannelTable>

This command selects a channel table configured for the link direction you have selected.

For more information see "[Working with Channel Tables](#)" on page 88.

Parameter

<ChannelTable>

String containing the file name of the channel table.

Characteristics

*RST value: -
 SCPI: device-specific

[SENSe]:FREQUENCY:CENTer<cc> <Frequency>

This command defines the center frequency.

Parameter

<Frequency>
 Numeric value in Hz.

The range depends on the operating mode and is specified in the data sheet.

Example

FREQ:CENT2 100MHz
 Defines a center frequency of 100 MHz for the second component carrier.

Characteristics

*RST value: $f_{\max} / 2$ with f_{\max} = maximum frequency
 SCPI: conform

[SENSe]:FREQUENCY:INPut:MODE<cc> <InputMode>

This command selects the frequency mode. Select the Channel frequency mode only if you want to work with channel tables. In this case, the input of the center frequency is not a frequency value, but a channel number.

Parameter

<InputMode>

FREQUENCY	Sets the frequency input mode to frequency input (in Hz).
CHANnel	Sets the frequency input mode to selection of a channel.

Example

FREQ:INP:MODE CHAN
 Sets the frequency mode to work with channel tables.

Characteristics

*RST value: FREQ
 SCPI: device-specific

7.7.6.2 Setting Amplitude Parameters

The following commands configure the vertical axis and level parameters of the active display.

The suffix <n> in the following commands is irrelevant.

List of commands

- [CALCulate:MARKer:FUNCtion:LEVel ONCE](#) (p. 183)
- [CONFigure:POWer:EXPected:RF <RefLevel>](#) (p. 242)
- [DISPlay\[:WINDow\]:TRACe<n>:Y\[:SCALe\]:RLEVel:OFFSet <Offset>](#) (p. 44)
- [INPut<n>:ATTenuation <Attenuation>](#) (p. 44)
- [INPut<n>:ATTenuation:AUTO](#) (p. 45)
- [INPut<n>:ATTenuation:MODE](#) (p. 45)
- [INPut<n>:GAIN:STATe](#) (p. 46)

CONFigure:POWer:EXPected:RF <RefLevel>

This command sets the reference level.

Parameter

<ReferenceLevel>

numeric value that sets the reference level; the unit is dBm.

The available value range is specified in the data sheet.

Example

```
CONF:POW:EXP:RF -70
```

Defines a reference level of -70 dBm

Characteristics

*RST value: -20 dBm

SCPI: device-specific

7.7.6.3 Working with Traces

The following commands set up the trace and the various functions associated with it, e.g. the selection of the detector.

The suffix <n> in the following commands is irrelevant.

List of commands

- [DISPlay\[:WINDow\]:TRACe<n>:MEMory\[:STATe\] <State>](#) (p. 61)
- [DISPlay\[:WINDow\]:TRACe<n>:MODE <TraceMode>](#) (p. 62)
- [DISPlay\[:WINDow\]:TRACe<n>\[:STATe\] <State>](#) (p. 61)

For a detailed description of commands refer to "[Working with Traces](#)" in spectrum analyzer mode.

7.7.6.4 Performing and Triggering the Measurement

The following commands initialize a measurement and set up the sweep.

List of commands

- [*WAI](#) (p. 35)
- [ABORt](#) (p. 51)
- [INITiate\[:IMMediate\]](#) (p. 51)
- [INITiate:CONTinuous <SweepMode>](#) (p. 52)
- [TRIGger\[:SEquence\]:SOURce <TriggerSource>](#) (p. 243)

For a detailed description of commands refer to "[Performing and Triggering Measurements](#)" in spectrum analyzer mode.

TRIGger[:SEquence]:SOURce <TriggerSource>

This command sets the type of trigger the R&S FSH uses.

Parameter

<TriggerSource>

IMMediate	Free Run
EXTernal	External trigger
GPSSync	GPS trigger

For more information see [TRIGger<n>\[:SEquence\]:SOURce <TriggerSource>](#) and the operating manual.

7.7.6.5 Selecting the Result Display

Use the following commands to select the result display.

List of commands

- [CALCulate:FEED <Result Display>](#) (p. 243)
- [\[SENSe:\]BWIDth:OCCupied:STATe <State>](#) (p. 244)

CALCulate:FEED <Result Display>

This command selects the result display.

Parameter

<ResultDisplay>

'CONS:CONS'	Selects the Constellation Diagram.
'SPEC:IANTenna'	Selects the isotropic antenna results.
'SPEC:PSPE'	Selects the Spectrum Overview.
'SPEC:PVSR'	Selects the Resource Allocation results.

'STAT:CAGR'	Selects the Carrier Aggregation results.
'STAT:SCAN'	Selects the BTS Scanner.
'STAT:LIMits'	Selects the limit check results.
'STAT:RSUM'	Selects the Result Summary.

Example

```
CALC:FEED 'CONS:CONS'
```

Selects the constellation diagram.

Characteristics

*RST value: 'STAT:RSUM'
 SCPI: device-specific

[SENSe:]BWIDth:OCCupied:STATe <State>

This command turns the calculation of the occupied bandwidth on and off.

Parameter

<State>
 ON | OFF

Example

```
BWID:OCC:STAT ON
```

Turns on the occupied bandwidth calculation.

Characteristics

*RST value: ON
 SCPI: device-specific

7.7.6.6 Configuring the Measurement

The following commands configure measurements on LTE signals.

The suffix <cc> selects the component carrier. The range is 1 to 5.

List of commands

- [CONFigure\[:LTE\]:DL:BW<cc> <Bandwidth>](#) (p. 245)
- [CONFigure\[:LTE\]:DL:CSUBframes <Subframes>](#) (p. 245)
- [CONFigure\[:LTE\]:DL:CYCPrefix <Prefix>](#) (p. 246)
- [CONFigure\[:LTE\]:DL:MIMO:ASElection <Antenna>](#) (p. 246)
- [CONFigure\[:LTE\]:DL:MIMO<cc>:CONFig <Configuration>](#) (p. 246)
- [CONFigure\[:LTE\]:DL:NCARriers <Carrier>](#) (p. 247)
- [CONFigure\[:LTE\]:DL:NORB <ResourceBlocks>](#) (p. 247)
- [CONFigure\[:LTE\]:DL:PLCI:CIDNtity <CellID>](#) (p. 247)
- [CONFigure\[:LTE\]:DL:PLCI:CIDGroup <GroupID>](#) (p. 248)
- [CONFigure\[:LTE\]:DL:PLCI:PLID <Identity>](#) (p. 248)
- [CONFigure\[:LTE\]:DL:TDD:UDConfig <Configuration>](#) (p. 249)

- [\[SENSe\]:LTE:DL:DEMod:EVM:ASTD <State>](#) (p. 249)
- [\[SENSe\]:LTE:DL:DEMod:SYNCh <SyncSignal>](#) (p. 249)
- [UNIT:CFE <Unit>](#) (p. 250)
- [UNIT:EVM <Unit>](#) (p. 250)

CONFigure[LTE]:DL:BW<cc> <Bandwidth>

This command selects the channel bandwidth of the signal.

Note that changing the channel bandwidth will also change the number of resource blocks.

Parameter

<Bandwidth>

BW1_40	1.40 MHz
BW3_00	3 MHz
BW5_00	5 MHz
BW10_00	10 MHz
BW15_00	15 MHz
BW20_00	20 MHz

Example

```
CONF:DL:BW BW20_00
```

Selects a 20 MHz bandwidth.

Characteristics

*RST value: BW10_00
 SCPI: device-specific

CONFigure[LTE]:DL:CSUBframes <Subframes>

This command defines the number of subframes to analyze.

Parameter

<Subframes>

numeric value in the range from 1 to 10.

Example

```
CONF:DL:CSUB 5
```

Analyzes 5 subframes.

Characteristics

*RST value: 10
 SCPI: device-specific

CONFigure[:LTE]:DL:CYCPrefix <Prefix>

This command selects the cyclic prefix mode.

Parameter

<Prefix>

NORM	Normal cyclic prefix.
EXT	Extended cyclic prefix.
AUTO	Automatic detection of the cyclic prefix.

Example

```
CONF:DL:CYCP AUTO
```

Selects automatic detection of the cyclic prefix.

Characteristics

*RST value: AUTO

SCPI: device-specific

CONFigure[:LTE]:DL:MIMO:ASElection <Antenna>

This command selects the antenna under test in a MIMO setup.

Parameter

<Antenna>

ANT1	Measurement on antenna 1.
ANT2	Measurement on antenna 2.
ALL	Measurement on all antennas.

Example

```
CONF:DL:MIMO:ASEL ALL
```

Analyzes the signal on all antennas (over-the-air).

Characteristics

*RST value: ALL

SCPI: device-specific

CONFigure[:LTE]:DL:MIMO<cc>:CONFig <Configuration>

This command selects the MIMO configuration.

Parameter

<Configuration>

TX1	One antenna setup.
TX2	Two antenna setup.
TX4	Four antenna setup.

Example

```
CONF:DL:MIMO:CONF TX4
```

Selects a 4 antenna setup.

Characteristics

*RST value: TX1
SCPI: device-specific

CONFigure[:LTE]:DL:NCARriers <Carrier>

This command selects the number of component carriers.

Parameter

<Carrier>

The R&S FSH supports measurements on systems with 2 or 3 component carriers.

Example

```
CONF:DL:NCAR 2
```

Selects 2 component carriers.

Characteristics

*RST value: 3
SCPI: device-specific

CONFigure[:LTE]:DL:NORB <ResourceBlocks>

This command selects the number of resource blocks.

Note that changing the number of resource blocks will also change the channel bandwidth.

Parameter

<ResourceBlocks>
6, 15, 25, 50, 75, 100

Example

```
CONF:DL:NORB 50
```

Selects 50 resource blocks (10 MHz bandwidth).

Characteristics

*RST value: 50
SCPI: device-specific

CONFigure[:LTE]:DL:PLCI:CIDNtity <CellID>

This command defines the identity of the cell under test.

Note that the R&S FSH automatically calculates the cell ID if you define a cell identity group and a physical layer cell identity.

Parameter

<CellID>

 AUTO Automatically determines the cell ID.

 <CellID> Manual selection of the cell ID. Numeric value in the range from 0 to 503.

Example

```
CONF:DL:PLCI:CIDN AUTO
```

 Automatically detects the cell ID.
Characteristics
 *RST value: AUTO
 SCPI: device-specific
CONFigure[:LTE]:DL:PLCI:CIDGroup <GroupID>

 This command defines the cell identity group.
Parameter

<GroupID>

 AUTO Automatically determines the cell identity group.

 <GroupID> Manual selection of the cell ID group. Numeric value in the range from 0 to 167.

Example

```
CONF:DL:PLCI:CIDG 100
```

 Selects the cell identity group.
Characteristics
 *RST value: AUTO
 SCPI: device-specific
CONFigure[:LTE]:DL:PLCI:PLID <Identity>

 This command defines the physical layer identity.
Parameter

<Identity>

 AUTO Automatically determines the identity.

 <Identity> Manual selection of the identity. Numeric value in the range from 0 to 2.

Example

```
CONF:DL:PLCI:CIDN 0
```

 Selects physical layer cell identity.

Characteristics

*RST value: AUTO
 SCPI: device-specific

CONFigure[:LTE]:DL:TDD:UDConfig <Configuration>

This command selects the UL and DL configuration that defines the order of allocations used inside a subframe.

Parameter

<Configuration>
 numeric value from 0 to 6

The number corresponds to the number the configuration (e.g. '2' selects subframe configuration 2).

Example

```
CONF:DL:TDD:UDC 2
```

Selects TDD configuration 2.

Characteristics

*RST value: 0
 SCPI: device-specific

[SENSe][:LTE]:DL:DEMod:EVM:ASTD <State>

This command turns the calculation of the EVM according to the standard on and off.

Parameter

<State>
 ON | OFF

Example

```
DL:DEMod:EVM:ASTD ON
```

Turns on EVM calculation according to standard.

Characteristics

*RST value: OFF
 SCPI: device-specific

[SENSe][:LTE]:DL:DEMod:SYNCh <SyncSignal>

This command selects the synchronization signal.

Parameter

<SyncSignal>

AUTO	Automatically selects the synchronization signal.
PSYN	Synchronization signal is the P-SYNC and S-SYNC.
REFS	Synchronization signal is the synchronization signal if the cell ID is known.

Example

```
DL:DEM:SYNC PSYN
```

Selects the P-SYNC and S-SYNC as the synchronization signal.

Characteristics

*RST value: ALL

SCPI: device-specific

UNIT:CFE <Unit>

This command sets the unit for the carrier frequency error result.

Parameter

<Unit>

HZ | PPM

Example

```
UNIT:CFE HZ
```

Selects the unit Hertz.

Characteristics

*RST value: OFF

SCPI: device-specific

UNIT:EVM <Unit>

This command sets the unit for the EVM results.

Parameter

<Unit>

DB | PCT

Example

```
UNIT:EVM DB
```

Selects the unit dB.

Characteristics

*RST value: OFF

SCPI: device-specific

7.7.6.7 Using An Isotropic Antenna

This chapter describes all commands available to set up measurements with an isotropic antenna.

List of commands

- [INPut:ANTenna:MEASure <Direction>](#) (p. 117)
- [\[SENSe:\]CORRection:TRANsducer<c>:ISOTropic\[:STATe\]?](#) (p. 118)

7.7.6.8 Getting Measurement Results

The following commands read out measurement results of LTE measurements.

The suffix <cc> selects the component carrier. The range is 1 to 5.

- [FETCh:CYCPrefix?](#) (p. 251)
 - [FETCh:PLCI:CIDNtity<cc>?](#) (p. 252)
 - [FETCh:PLCI:CIDGroup<cc>?](#) (p. 252)
 - [FETCh:PLCI:PLID<cc>?](#) (p. 252)
 - [FETCh:SUMMary:POWer<cc>?](#) (p. 253)
 - [FETCh:SUMMary:FERRor<cc>?](#) (p. 253)
 - [FETCh:SUMMary:IQOFfset?](#) (p. 253)
 - [FETCh:SUMMary:EVM?](#) (p. 254)
 - [FETCh:SUMMary:EVM:<modulation>?](#) (p. 254)
 - [FETCh:SUMMary:EVM:<channel>?](#) (p. 255)
 - [FETCh:SUMMary:EVM:RSIGnal<cc>? <Antenna>](#) (p. 255)
 - [FETCh:SUMMary:OSTP?](#) (p. 256)
 - [FETCh:SUMMary:POWer:<modulation>?](#) (p. 256)
 - [FETCh:SUMMary:POWer:<channel>?](#) (p. 256)
 - [FETCh:SUMMary:POWer:RSIGnal<cc>? <Antenna>](#) (p. 257)
 - [FETCh:SUMMary:POWer:SYNCsignal<cc>?](#) (p. 257)
 - [FETCh:SUMMary:RSRP?](#) (p. 258)
 - [FETCh:SUMMary:RSRQ?](#) (p. 258)
 - [FETCh:SUMMary:SINR?](#) (p. 258)
 - [FETCh:SUMMary:RSSI?](#) (p. 259)
 - [FETCh:SUMMary:TAE<cc>? <Antenna>](#) (p. 259)
 - [FETCh:SUMMary:TRAFfic](#) (p. 260)
 - [\[SENSe:\]BWIDth:OCCupied?](#) (p. 195)
- [Using the TRACe\[:DATA\] Command](#) (p. 260)

FETCh:CYCPrefix?

This command queries the cyclic prefix mode when automatic cyclic prefix detection has been turned on with [CONFigure\[:LTE\]:DL:CYCPrefix](#) `AUTO`.

Return value

EXT	Extended cyclic prefix.
NORM	Normal cyclic prefix.

Example

FETC:CYCP?
Queries the cyclic prefix.

Characteristics

*RST value: -
SCPI: device-specific

FETCh:PLCI:CIDNtity<cc>?

This command queries the cell identity.

Return value

<CellIdentity>
Number between 0 and 503.

Example

FETC:PLCI:CIDN?
Queries the cell identity.

Characteristics

*RST value: -
SCPI: device-specific

FETCh:PLCI:CIDGroup<cc>?

This command queries the cell identity group.

Return value

<CellIdentityGroup>
Number between 0 and 167.

Example

FETC:PLCI:CIDG?
Queries the cell identity group.

Characteristics

*RST value: -
SCPI: device-specific

FETCh:PLCI:PLID<cc>?

This command queries the physical layer ID.

Return value

<ID>
Number between 0 and 2.

Example

```
FETC:PLCI:PLID?
```

Queries the physical layer ID.

Characteristics

*RST value: -

SCPI: device-specific

FETCh:SUMMary:POWer<cc>?

This command queries the total power of the signal.

Return value

<Power>

Total power in dBm.

Example

```
FETC:SUMM:POW?
```

Queries the total power.

Characteristics

*RST value: -

SCPI: device-specific

FETCh:SUMMary:FERRor<cc>?

This command queries the carrier frequency error.

Return value

<FrequencyError>

Frequency error. The unit is either kHz or ppm, depending on [UNIT:CFE](#).

Example

```
FETC:SUMM:FERR?
```

Queries the frequency error.

Characteristics

*RST value: -

SCPI: device-specific

FETCh:SUMMary:IQOFfset?

This command queries the I/Q offset.

Return value

<Offset>

I/Q offset in dB.

Example

FETC : SUMM : IQOF?
 Queries the I/Q offset.

Characteristics

*RST value: -
 SCPI: device-specific

FETCh:SUMM:EVm?

This command queries the overall EVM.

Return value

<EVM>
 EVM in dB or %. The unit depends on `UNIT : EVM <Unit>`.

Example

FETC : SUMM : EVM?
 Queries the overall EVM.

Characteristics

*RST value: -
 SCPI: device-specific

FETCh:SUMM:EVm:<modulation>?

This command queries the EVM for resource elements with a particular modulation scheme in the signal.

Replace <modulation> syntax part with

DSQP	for the EVM of QPSK modulated signal parts
DSST	for the EVM of 16QAM modulated signal parts
DSSF	for the EVM of 64QAM modulated signal parts
DSTS	for the EVM of 256QAM modulated signal parts

Return value

<EVM>
 EVM in dB or %. The unit depends on `UNIT : EVM <Unit>`.

Example

FETC : SUMM : EVm : DSQP?
 Queries the EVM of the signal parts with QPSK modulation.

Characteristics

*RST value: -
 SCPI: device-specific

FETCh:SUMM:EVm:<channel>?

This command queries the EVM for resource elements of a particular channel.

Replace the <channel> syntax with

PSYNc	for the EVM of the PSYNC channel
SSYNc	for the EVM of the SSYNC channel
PBCH	for the EVM of the PBCH
PCFich	for the EVM of the PCFICH

Return value

<EVM>

EVM in dB or %. The unit depends on `UNIT:EVm <Unit>`.

Example

```
FETC:SUMM:EVm:PBCH?
```

Queries the EVM of the PBCH.

Characteristics

*RST value: -

SCPI: device-specific

FETCh:SUMM:EVm:RSIG<cc>? <Antenna>

This command queries the EVM of the reference signal.

Parameter

ANT1 | ANT2 | ANT3 | ANT4

Selects a particular antenna (1 to 4) to query the EVM for.

If you do not add a parameter, the command returns

- the currently displayed reference signal EVM (single antenna measurements)
- the reference signal EVM of TX1 (over-the-air measurements)

Return value

<EVM>

EVM in dB or %. The unit depends on `UNIT:EVm <Unit>`.

Example

```
FETC:SUMM:EVm:RSIG? ANT1
```

Queries the EVM of the reference signal on antenna 1.

Characteristics

*RST value: -

SCPI: device-specific

FETCh:SUMMary:OSTP?

This command queries the OSTP.

Return value

<OSTP>
OSTP in dBm.

Example

```
FETC:SUMM:OSTP?  
Queries the OSTP.
```

Characteristics

*RST value: -
SCPI: device-specific

FETCh:SUMMary:POWer:<modulation>?

This command queries the power of resource elements with a particular modulation scheme.

Replace <modulation> syntax part with

DSQP	for the power of QPSK modulated signal parts
DSST	for the power of 16QAM modulated signal parts
DSSF	for the power of 64QAM modulated signal parts
DSTS	for the power of 256QAM modulated signal parts

Example

```
FETC:SUMM:POW:DSST?  
Queries the power of all signal parts with a 16QAM modulation.
```

Return value

<Power>
Power in dBm.

Characteristics

*RST value: -
SCPI: device-specific

FETCh:SUMMary:POWer:<channel>?

This command queries the power for resource elements of a particular channel.

Replace the <channel> syntax with

PSYNc	for the power of the PSYNC channel
SSYNc	for the power of the SSYNC channel

PBCH	for the power of the PBCH
PCFICH	for the power of the PCFICH

Example

```
FETC:SUMM:POW:SSYN?
```

Queries the power of the S-SYNC.

Return value

```
<Power>
```

Power in dBm.

Characteristics

*RST value: -

SCPI: device-specific

FETCh:SUMMary:POWer:RSIGnal<cc>? <Antenna>

This command queries the power of the reference signal.

Parameter

```
ANT1 | ANT2 | ANT3 | ANT4
```

Selects a particular antenna (1 to 4) to query the EVM for.

If you do not add a parameter, the command returns

- the currently displayed reference signal power (single antenna measurements)
- the reference signal power of TX1 (over-the-air measurements)

Return value

```
<Power>
```

Power in dBm.

Example

```
FETC:SUMM:POW:RSIG? ANT2
```

Queries the reference signal power on antenna 1.

Characteristics

*RST value: -

SCPI: device-specific

FETCh:SUMMary:POWer:SYNCsignal<cc>?

This command queries the power of the synchronization signal.

Return value

```
<Power>
```

Power in dBm.

Example

```
FETC : SUMM : POW : SYNC ?
```

Queries the power of the synchronization signal.

Characteristics

*RST value: -

SCPI: device-specific

FETCh:SUMMary:RSRP?

This command queries the RSRP.

Return value

<RSRP>

Numeric value in dBm.

Example

```
FETC : SUMM : RSRP ?
```

Queries the RSRP.

Characteristics

*RST value: -

SCPI: device-specific

FETCh:SUMMary:RSRQ?

This command queries the RSRQ.

Return value

<RSRQ>

Numeric value in dB.

Example

```
FETC : SUMM : RSRQ ?
```

Queries the RSRQ.

Characteristics

*RST value: -

SCPI: device-specific

FETCh:SUMMary:SINR?

This command queries the SINR.

Return value

<SINR>

Numeric value in dB.

Example

```
FETC:SUMM:SINR?
```

Queries the SINR.

Characteristics

*RST value: -

SCPI: device-specific

FETCh:SUMMary:RSSI?

This command queries the RSSI.

Return value

<RSRP>

Numeric value in dBm.

Example

```
FETC:RSSI?
```

Queries the RSSI.

Characteristics

*RST value: -

SCPI: device-specific

FETCh:SUMMary:TAE<cc>? <Antenna>

This command queries the time alignment error.

Suffix

<CC>

Selects the component carrier.

Parameter

<Antenna>

ANT1 | ANT2 | ANT3 | ANT4

Return value

<Time Alignment Error>

Numeric value in s.

Example

```
FETC:SUMM:TAE? ANT4
```

Queries the time alignment error of antenna 4.

Characteristics

*RST value: -

SCPI: device-specific

FETCh:SUMM:TRAFfic

This command queries the traffic activity.

Return value

<Activity>
Traffic activity in %.

Example

```
FETC:SUMM:TRAF?
Queries the traffic activity.
```

Characteristics

*RST value: -
SCPI: device-specific

7.7.6.9 Using the TRACe[:DATA] Command

The TRACe[:DATA] command queries the trace data or results of the currently active measurement or result display. The type, number and structure of the return values are specific for each result display.

The format of the return values is either in ASCII or binary characters and depends on the format you have set with FORMat[:DATA] <DataFormat>.

Result Summary

The command returns the contents of the result summary. The number and type of return values depend on the antenna settings.

The number of results also depends on the parameter you append to the command.

- TRACe:DATA? TRACE1 returns the data with a normal font
- TRACe:DATA? ALL also returns the results in a bold font

MIMO 2x2 Connected to TX1 and SISO Measurement

```
<ChannelPower>,<CellIdentity>,<CellGroup>,<CellID>,<CompositeEVM>,<CyclicPrefix>,<CarrierFreqError>,<Traffic>,<SyncSignalPower>,<SINR>,<OSTP>,<RSSI>,<RSRP>,<RSRQ>,<FrameOffset>,<OccupiedBW>,<IQOffset>,<RefSignalPowerAnt1>,<RefSignalEVMAnt1>,<PSYNCPower>,<PSYNC_EVM>,<QPSKPower>,<QPSK_EVM>,<SSYNCPower>,<SSYNC_EVM>,<16QAMPower>,<16QAM_EVM>,<PBCHPower>,<PBCH_EVM>,<64QAMPower>,<64QAM_EVM>,<PCFICHPower>,<PCFICH_EVM>,<256QAMPower>,<256QAM_EVM>
```

MIMO 2x2 Connected to TX2

<ChannelPower>,<CellIdentity>,<CellGroup>,<CellID>,<CompositeEVM>,
 <CyclicPrefix>,<CarrierFreqError>,<Traffic>,<SyncSignalPower>,<SINR>,
 <OSTP>,<RSSI>,<RSRP>,<RSRQ>,<FrameOffset>,<OccupiedBW>,
 <IQOffset>,<RefSignalPowerAnt2>,<RefSignalEVMAnt2>,<PSYNCPower>,
 <PSYNC_EVM>,<QPSKPower>,<QPSK_EVM>,<SSYNCPower>,
 <SSYNC_EVM>,<16QAMPower>,<16QAM_EVM>,<PBCHPower>,
 <PBCH_EVM>,<64QAMPower>,<64QAM_EVM>,<PCFICHPower>,
 <PCFICH_EVM>,<256QAMPower>,<256QAM_EVM>

MIMO 2x2 Over-the-Air

<ChannelPower>,<CellIdentity>,<CellGroup>,<CellID>,<CompositeEVM>,
 <CyclicPrefix>,<CarrierFreqError>,<Traffic>,<SyncSignalPower>,<SINR>,
 <OSTP>,<RSSI>,<RSRP>,<RSRQ>,<FrameOffset>,<OccupiedBW>,
 <RefSignalPowerAnt1>,<RefSignalEVMAnt1>,<RefSignalTAE1 Ant1>,
 <RefSignalPowerAnt2>,<RefSignalEVMAnt2>,<RefSignalTAE1 Ant2>

MIMO 4x4 Over-the-Air

<ChannelPower>,<CellIdentity>,<CellGroup>,<CellID>,<CompositeEVM>,
 <CyclicPrefix>,<CarrierFreqError>,<Traffic>,<SyncSignalPower>,<SINR>,
 <OSTP>,<RSSI>,<RSSP>,<RSRQ>,<FrameOffset>,<OccupiedBW>,
 <RefSignalPowerAnt1>,<RefSignalEVMAnt1>,<RefSignalTAE1 Ant1>,
 <RefSignalPowerAnt2>,<RefSignalEVMAnt2>,<RefSignalTAE1 Ant1>,
 <RefSignalPowerAnt3>,<RefSignalEVMAnt3>,<RefSignalTAE1 Ant3>,
 <RefSignalPowerAnt4>,<RefSignalEVMAnt4>,<RefSignalTAE1 Ant4>

The unit of the EVM results depends on `UNIT:EVM` <Unit>.

Spectrum Overview and Isotropic Antenna

The command returns 631 values. Each value corresponds to one pixel of the trace.

Resource Allocations

The command returns the power in dBm of all data resource blocks, beginning with the lowest carrier in the first subframe.

BTS Scanner

For each cell, the command returns seven values.

<CellIdentity1>,<CellGroup1>,<CellID1>,<PSYNCPower1>,<SSYNCPower1>,
 <Reserved>,<Reserved>,...

TRACe:DATA? <Trace>

This command queries the measurement results.

Parameter

TRACE1 | ALL

Example

TRAC? TRACE1
Queries the results.

Characteristics

*RST value: -
SCPI: conform

7.7.7 Performing Measurements on NB-IoT Signals

When you perform measurements on LTE signals, you can use the remote commands described in this chapter.



Availability of remote commands

Note that the listed remote commands take effect only if option R&S FSH-K56 is installed.

7.7.7.1 Setting the Frequency

The following commands configure the frequency axis (x-axis) of the active display.

The suffix <n> in the following commands is irrelevant.

List of commands

- [\[SENSe:\]CHANnel<n> <ChannelNumber>](#) (p. 89)
- [\[SENSe:\]CHANnel:TABLE:SElect <ChannelTable>](#) (p. 89)
- [\[SENSe:\]FREQUENCY:CENTer<n> <Frequency>](#) (p. 37)
- [\[SENSe:\]FREQUENCY:INPut:MODE<n> <InputMode>](#) (p. 38)

For a detailed description of the commands refer to "[Configuring the Horizontal Axis](#)" in spectrum analyzer mode.

7.7.7.2 Setting Amplitude Parameters

The following commands configure the vertical axis and level parameters of the active display.

The suffix <n> in the following commands is irrelevant.

List of commands

- [CALCulate:MARKer:FUNction:LEVel ONCE](#) (p. 183)
- [CONFigure:POWer:EXPEcted:RF <RefLevel>](#) (p. 263)
- [DISPlay\[:WINDow\]:TRACe<n>:Y\[:SCALe\]:RLEVel:OFFSet <Offset>](#) (p. 44)
- [INPut<n>:ATTenuation <Attenuation>](#) (p. 44)
- [INPut<n>:ATTenuation:AUTO](#) (p. 45)
- [INPut<n>:ATTenuation:MODE](#) (p. 45)
- [INPut<n>:GAIN:STATe](#) (p. 46)

CONFigure:POWer:EXPEcted:RF <RefLevel>

This command sets the reference level.

Parameter

<ReferenceLevel>

numeric value that sets the reference level; the unit is dBm.

The available value range is specified in the data sheet.

Example

CONF:POW:EXP:RF -70

Defines a reference level of -70 dBm.

Characteristics

*RST value: -20 dBm

SCPI: device-specific

7.7.7.3 Working with Traces

The following commands set up the trace and the various functions associated with it, e.g. the selection of the detector.

The suffix <n> in the following commands is irrelevant.

List of commands

- [DISPlay\[:WINDow\]:TRACe<n>:MEMory\[:STATe\] <State>](#) (p. 61)
- [DISPlay\[:WINDow\]:TRACe<n>:MODE <TraceMode>](#) (p. 62)
- [DISPlay\[:WINDow\]:TRACe<n>\[:STATe\] <State>](#) (p. 61)

For a detailed description of commands refer to "[Working with Traces](#)" in spectrum analyzer mode.

7.7.7.4 Performing and Triggering the Measurement

The following commands initialize a measurement and set up the sweep.

List of commands

- [*WAI](#) (p. 35)
- [ABORt](#) (p. 51)
- [INITiate\[:IMMEDIATE\]](#) (p. 51)
- [INITiate:CONTinuous <SweepMode>](#) (p. 52)
- [TRIGger\[:SEquence\]:SOURce <TriggerSource>](#) (p. 264)

For a detailed description of commands refer to "[Performing and Triggering Measurements](#)" in spectrum analyzer mode.

TRIGger[:SEquence]:SOURce <TriggerSource>

This command sets the type of trigger the R&S FSH uses.

Parameter

<TriggerSource>

IMMediate	Free Run
EXTernal	External trigger
GPSSync	GPS trigger

For more information see [TRIGger<n>\[:SEQuence\]:SOURce <TriggerSource>](#) and the operating manual.

7.7.7.5 Selecting the Result Display

Use the following commands to select the result display.

List of commands

- [CALCulate:FEED <Result Display>](#) (p. 265)

CALCulate:FEED <Result Display>

This command selects the result display.

Parameter

<ResultDisplay>

'CONS:CONS'	Selects the Constellation Diagram.
'SPEC:PSPE'	Selects the Spectrum Overview.
'STAT:RSUM'	Selects the Result Summary.

Example

```
CALC:FEED 'STAT:PSPE'
```

Selects the spectrum overview.

Characteristics

*RST value: 'STAT:RSUM'
SCPI: device-specific

7.7.7.6 Configuring the Measurement

The following commands configure measurements on NB-IoT signals.

List of commands

- [CONFigure\[:LTE\]:DEPLoyment <Deployment>](#) (p. 266)
- [CONFigure\[:LTE\]:DL:BW<cc> <Bandwidth>](#) (p. 266)
- [CONFigure\[:LTE\]:DL:CSUBframes <Subframes>](#) (p. 267)
- [CONFigure\[:LTE\]:DL:DEMod :MCFilter <State>](#) (p. 267)
- [CONFigure\[:LTE\]:DL:MIMO:ASElection <Antenna>](#) (p. 267)
- [CONFigure\[:LTE\]:DL:PLCI:CIDNtity <CellID>](#) (p. 268)
- [CONFigure\[:LTE\]:DL:PLCI:CIDGroup <GroupID>](#) (p. 268)

- [CONFigure\[:LTE\]:DL:PLCI:PLID <Identity>](#) (p. 269)
- [CONFigure\[:LTE\]:DL:SINFo <Sequence>](#) (p. 270)
- [CONFigure\[:LTE\]:DL:PINDeX <Index>](#) (p. 270)
- [CONFigure\[:LTE\]:DL:PSOFset <Offset>](#) (p. 271)
- [UNIT:CFE <Unit>](#) (p. 271)
- [UNIT:EVM <Unit>](#) (p. 272)

CONFigure[:LTE]:DEPLoyment <Deployment>

This command selects the deployment of the NB-IoT carrier.

Parameter

<Deployment>

GBANd	NB-IoT uses resource blocks of the guard band of an LTE carrier.
INBAND	NB-IoT uses resource blocks within an LTE carrier.
SALone	NB-IoT uses a frequency band outside of an LTE carrier.

Note: To select the "Standalone + Adjacent" deployment, select standalone deployment and turn on the NB-IoT filter with [CONFigure\[:LTE\]:DL:DEMod:MCFilter <State>](#).

Example

```
CONF:DEPL INB
```

Selects the inband deployment.

```
CONF:DEPL SAL
```

```
CONF:DL:DEM:MCF ON
```

Selects the standalone + adjacent deployment.

Characteristics

*RST value: SALone

SCPI: device-specific

CONFigure[:LTE]:DL:BW<cc> <Bandwidth>

This command selects the channel bandwidth of the E-UTRA carrier.

Parameter

<Bandwidth>

BW3_00	3 MHz
BW5_00	5 MHz
BW10_00	10 MHz
BW15_00	15 MHz
BW20_00	20 MHz

Example

```
CONF:DL:BW 20_00
```

Defines an LTE bandwidth of 20 MHz.

Characteristics

*RST value: BW10_00
 SCPI: device-specific

CONFigure[:LTE]:DL:CSUBframes <Subframes>

This command defines the number of subframes to analyze.

Parameter

<Subframes>
 numeric value in the range from 1 to 10.

Example

```
CONF:DL:CSUB 5
```

Analyzes 5 subframes.

Characteristics

*RST value: 10
 SCPI: device-specific

CONFigure[:LTE]:DL:DEMod :MCFilter <State>

This command turns the NB-IoT multicarrier filter on and off.

Parameter

<State>
 ON | OFF.

Example

```
CONF:DL:DEMod:MCF ON
```

Turns on the NB-IoT filter.

Characteristics

*RST value: OFF
 SCPI: device-specific

CONFigure[:LTE]:DL:MIMO:ASElection <Antenna>

This command selects the antenna configuration.

Parameter

<Antenna>

ANT1	Conducted measurement.
ALL	Over-the-air measurement.

Example

```
CONF:DL:MIMO:ASEL ALL
Selects over-the-air measurement.
```

Characteristics

*RST value: ANT1
 SCPI: device-specific

CONFigure[:LTE]:DL:PLCI:CIDNtity <CellID>

This command defines the identity of the cell under test.

Note that the R&S FSH automatically calculates the cell ID if you define a cell identity group and a physical layer cell identity.

Parameter

<CellID>

AUTO	Automatically determines the cell ID.
<CellID>	Manual selection of the cell ID. Numeric value in the range from 0 to 503.

Example

```
CONF:DL:PLCI:CIDN AUTO
Automatically detects the cell ID.
```

Characteristics

*RST value: AUTO
 SCPI: device-specific

CONFigure[:LTE]:DL:PLCI:CIDGroup <GroupID>

This command defines the cell identity group.

Parameter

<GroupID>

AUTO	Automatically determines the cell identity group.
<GroupID>	Manual selection of the cell ID group. Numeric value in the range from 0 to 167.

Example

```
CONF:DL:PLCI:CIDG 100
Selects the cell identity group.
```

Characteristics

*RST value: AUTO
 SCPI: device-specific

CONFigure[:LTE]:DL:PLCI:PLID <Identity>

This command defines the physical layer identity.

Parameter

<Identity>

AUTO	Automatically determines the identity.
<Identity>	Manual selection of the identity. Numeric value in the range from 0 to 2.

Example

```
CONF:DL:PLCI:CIDN 0
```

Selects physical layer cell identity.

Characteristics

*RST value: AUTO
 SCPI: device-specific

CONFigure[:LTE]:DL:SINFo <Sequence>

This command defines the CRS sequence info of the E-UTRA channel.

The selected CRS sequence also defines the PRB index ([CONFigure\[:LTE\]:DL:PINDEX <Index>](#)).

Parameter

<Sequence>
 Number of the CRS sequence info.

Example

```
CONF:DL:SINF 20
```

Selects sequence info 20.

Characteristics

*RST value: depends on the E-UTRA channel bandwidth
 SCPI: device-specific

CONFigure[:LTE]:DL:PINDEX <Index>

This command defines the PRB index of the E-UTRA channel.

Note that the PRB index depends on the selected CRS sequence selected with [CONFigure\[:LTE\]:DL:SINFo <Sequence>](#).

Parameter

<Index>
 Number of the PRB index.

Example

```
CONF:DL:PIND 95
```

Selects PRB index 95.

Characteristics

*RST value: depends on the E-UTRA channel bandwidth
 SCPI: device-specific

CONFigure[:LTE]:DL:PSOffset <Offset>

This command defines the PRB symbol offset.

Parameter

<Offset>

Number in the range from 0 to 4.

Example

```
CONF:DL:PSOF 0
```

Defines a PRB symbol offset of 0.

Characteristics

*RST value: 0

SCPI: device-specific

[SENSe][:LTE]:DL:DEMod:EVM:ASTD <State>

This command turns the calculation of the EVM according to the standard on and off.

Parameter

<State>

ON | OFF

Example

```
DL:DEM:EVM:ASTD ON
```

Turns on EVM calculation according to standard.

Characteristics

*RST value: OFF

SCPI: device-specific

UNIT:CFE <Unit>

This command sets the unit for the carrier frequency error result.

Parameter

<Unit>

HZ | PPM

Example

```
UNIT:CFE HZ
```

Selects unit Hertz.

Characteristics

*RST value: HZ

SCPI: device-specific

UNIT:EVM <Unit>

This command sets the unit for the EVM results.

Parameter

<Unit>
DB | PCT

Example

UNIT:EVM DB
Selects unit dB.

Characteristics

*RST value: DB
SCPI: device-specific

7.7.7.7 Getting Measurement Results

The following commands read out measurement results of NB-IoT measurements.

List of commands

- [FETCh:PLCI:CIDNtity<cc>?](#) (p. 272)
- [FETCh:PLCI:CIDGroup<cc>?](#) (p. 273)
- [FETCh:PLCI:PLID<cc>?](#) (p. 273)
- [FETCh:SUMMary:EVM?](#) (p. 273)
- [FETCh:SUMMary:EVM:DSQP?](#) (p. 274)
- [FETCh:SUMMary:OSTP?](#) (p. 274)
- [FETCh:SUMMary:EVM:<channel>?](#) (p. 274)
- [FETCh:SUMMary:POWer<cc>?](#) (p. 275)
- [FETCh:SUMMary:POWer:DSQP?](#) (p. 275)
- [FETCh:SUMMary:POWer:<channel>?](#) (p. 275)
- [FETCh:SUMMary:SINR?](#) (p. 276)
- [FETCh:SUMMary:RSSI?](#) (p. 276)
- [FETCh:SUMMary:TRAFfic](#) (p. 277)

FETCh:PLCI:CIDNtity<cc>?

This command queries the cell identity.

Return value

<CellIdentity>
Number between 0 and 503.

Example

FETC:PLCI:CIDN?
Queries the cell identity.

Characteristics

*RST value: -
SCPI: device-specific

FETCH:PLCI:CIDGroup<cc>?

This command queries the cell identity group.

Return value

<CellIdentityGroup>
Number between 0 and 167.

Example

```
FETC:PLCI:CIDG?
```

Queries the cell identity group.

Characteristics

*RST value: -
SCPI: device-specific

FETCH:PLCI:PLID<cc>?

This command queries the physical layer ID.

Return value

<ID>
Number between 0 and 2.

Example

```
FETC:PLCI:PLID?
```

Queries the physical layer ID.

Characteristics

*RST value: -
SCPI: device-specific

FETCH:SUMM:ary:EVM?

This command queries the overall EVM.

Return value

<EVM>
EVM in dB or %. The unit depends on [UNIT:EVM <Unit>](#).

Example

```
FETC:SUMM:ary:EVM?
```

Queries the overall EVM.

Characteristics

*RST value: -
 SCPI: device-specific

FETCH:SUMMARY:EVM:DSQP?

This command queries the EVM for resource elements with QPSK modulation.

Return value

<EVM>
 EVM in dB or %. The unit depends on `UNIT:EVM <Unit>`.

Example

`FETCH:SUMMARY:EVM:DSQP?`
 Queries the EVM of the signal parts with QPSK modulation.

Characteristics

*RST value: -
 SCPI: device-specific

FETCH:SUMMARY:OSTP?

This command queries the OSTP.

Return value

<OSTP>
 OSTP in dBm.

Example

`FETCH:SUMMARY:OSTP?`
 Queries the OSTP.

Characteristics

*RST value: -
 SCPI: device-specific

FETCH:SUMMARY:EVM:<channel>?

This command queries the EVM for resource elements of a particular channel.

Replace the <channel> syntax with

NPSS	for the EVM of the NPSS channel
NSSS	for the EVM of the NSSS channel
NPBCh	for the EVM of the NPBCH
NRS	for the EVM of the reference signal

Return value

<EVM>

EVM in dB or %. The unit depends on `UNIT:EVM <Unit>`.

Example

```
FETC : SUMM : EVM : NSSS ?
```

Queries the EVM of the NSSS.

Characteristics

*RST value: -

SCPI: device-specific

FETCh:SUMMary:POWer<cc>?

This command queries the total power of the NB-IoT channel.

Return value

<Power>

Total power in dBm.

Example

```
FETC : SUMM : POW ?
```

Queries the total power.

Characteristics

*RST value: -

SCPI: device-specific

FETCh:SUMMary:POWer:DSQP?

This command queries the power of resource elements with a QPSK modulation.

Example

```
FETC : SUMM : POW : DSQP ?
```

Queries the power of all signal parts with a QPSK modulation.

Return value

<Power>

Power in dBm.

Characteristics

*RST value: -

SCPI: device-specific

FETCh:SUMMary:POWer:<channel>?

This command queries the power for resource elements of a particular channel.

Replace the <channel> syntax with

NPSS	for the power of the NPSS channel
NSSS	for the power of the NSSS channel
NPBCh	for the power of the NPBCH
NRS	for the power of the reference signal

Example

```
FETC:SUMM:POW:NRS?
```

Queries the power of the reference signal.

Return value

<Power>

Power in dBm.

Characteristics

*RST value: -

SCPI: device-specific

FETCh:SUMMArY:SiNR?

This command queries the SINR.

Return value

<SINR>

Numeric value in dB.

Example

```
FETC:SUMM:SiNR?
```

Queries the SINR.

Characteristics

*RST value: -

SCPI: device-specific

FETCh:SUMMArY:RSSI?

This command queries the RSSI.

Return value

<RSRP>

Numeric value in dBm.

Example

```
FETC:RSSI?
```

Queries the RSSI.

Characteristics

*RST value: -
 SCPI: device-specific

FETCh:SUMMary:TRAFfic

This command queries the traffic activity.

Return value

<Activity>
 Traffic activity in %.

Example

```
FETC : SUMM : TRAF ?
```

Queries the traffic activity.

Characteristics

*RST value: -
 SCPI: device-specific

7.7.7.8 Using the TRACe[:DATA] Command

The `TRACe[:DATA]` command queries the trace data or results of the currently active measurement or result display. The type, number and structure of the return values are specific for each result display.

The format of the return values is either in ASCII or binary characters and depends on the format you have set with `FORMat[:DATA] <DataFormat>`.

Result Summary

The command returns the contents of the result summary. The number of results also depends on the parameter you append to the command.

- `TRACe:DATA? TRACE1` returns the data with a normal font
- `TRACe:DATA? ALL` also returns the results in a bold font

```
<ChannelPower>,<CellIdentity>,<CellGroup>,<CellID>,<CompositeEVM>,  

<CarrierFreqError>,<Traffic>,<SyncSignalPower>,<SINR>,<OSTP>,<RSSI>,  

<FrameOffset>,<NRS_Power>,<NRS_EVM>,<NPSS_Power>,<NPSS_EVM>,  

<QPSK_Power>,<QPSK_EVM>,<NSSS_Power>,<NSSS_EVM>,<NPBCH_Power>,  

<NPBCH_EVM>
```

The unit of the EVM results depends on `UNIT:EVM <Unit>`.

Spectrum Overview

The command returns 631 values. Each value corresponds to one pixel of the trace.

TRACe:DATA? <Trace>

This command queries the measurement results.

Parameter

TRACE1

Example

```
TRAC? TRACE1  
Queries the results.
```

Characteristics

*RST value: -
SCPI: conform

7.8 File Management

The following commands perform various tasks in the context of file management.

These commands are independent from the operating mode.

List of commands

- [MMEMory:CATalog?](#) (p. 279)
- [MMEMory:CATalog:DIRectories?](#) (p. 280)
- [MMEMory:CDIRectory <Directory>](#) (p. 280)
- [MMEMory:COpy <SourceFile>,<DestinationFile>](#) (p. 280)
- [MMEMory:DATA <FileName>\[,<BlockData>\]](#) (p. 281)
- [MMEMory:DELeTe <File>](#) (p. 282)
- [MMEMory:FILE <File>](#) (p. 282)
- [MMEMory:FILE:DATE <FileName>,<Date>](#) (p. 282)
- [MMEMory:FILE:TIME <FileName>,<Time>](#) (p. 283)
- [MMEMory:INIT](#) (p. 283)
- [MMEMory:LOAD:STATe 1,<FileName>](#) (p. 284)
- [MMEMory:MDIRectory <Directory>](#) (p. 284)
- [MMEMory:MOVE <SourceFile>,<NewFileName>](#) (p. 284)
- [MMEMory:RDIRectory <Directory>](#) (p. 285)
- [MMEMory:STORe:STATe 1,<FileName>](#) (p. 285)
- [SYSTem:SET:LOCK <FileName>](#) (p. 286)
- [SYSTem:SET:UNLock <FileName>](#) (p. 286)

MMEMory:CATalog?

This command queries the files of the current directory.

You can select directories with [MMEMory:CDIRectory <Directory>](#).

This command is a query and therefore has no *RST value.

Return value

<UsedDiskSpace>,<FreeDiskSpace>,<FileName_1>,<SizeFile_1><Modification
DateFile_1>,<ModificationTimeFile_1>,...,<FileName_n>,<SizeFile_n>
<ModificationDateFile_n>,<ModificationTimeFile_n>

Example

```
MMEM:CDIR '\Public\Limit Lines'
Opens directory 'Limit Lines'
```

```
MMEM:CAT?
Returns all files in \Public\Limit Lines
```

Characteristics

*RST value: -
SCPI: conform

MMEMory:CATalog:DIRectories?

This command queries the directories of the current directory.

This command is a query and therefore has no *RST value.

Return value

<UsedMemory>,<FreeMemory>,<DirName_1>,<ModificationDateDir_1>,
<ModificationTimeDir_1>,...,<DirName_n>,<ModificationDateDir_n>,
<ModificationTimeDir_n>

Example

```
MMEM:CDIR '\Public'
```

Opens directory \Public.

```
MMEM:CAT:DIR?
```

Returns all directories in the \Public directory

Characteristics

*RST value: -

SCPI: device-specific

MMEMory:CDIRectory <Directory>

This command changes the current directory.

Parameter

<Directory>

String containing the path to another directory.

Example

```
MMEM:CDIR '\Public'
```

Opens directory \Public.

Characteristics

*RST value: -

SCPI: conform

MMEMory:COPY <SourceFile>,<DestinationFile>

This command copies one or more files to another directory.

This command is an event and therefore has no *RST value and no query.

Parameter

<SourceFile>

String containing the path and file name of the source file.

<DestinationFile>

String containing the path and name of the destination file.

Example

```
MMEM: COPY
'\Public\Standards\cdmaOne.obwstd', '\USB\cdmaOne.std'
```

Copies the cdmaOne standard file file to a memory stick.

Characteristics

*RST value: -
SCPI: conform

MMEMory:DATA <FileName>[,<BlockData>]

This command writes block data into a file. The delimiter must be set to EOI to obtain error-free data transfer.

When you query the contents of a file, you can save them in a file on the remote control computer.

The command is useful for reading stored settings files or trace data from the instrument or for transferring them to the instrument.

Parameter

<FileName>

String containing the path and file name.

<BlockData>

Data block with the structure

hash sign

<number> length of the length information

<number> length information of the binary data (number of bytes)

<data> binary data with the indicated number of bytes

Example

```
MMEM:NAME '\Public\User\Testfile.txt'
```

Creates a new file called 'Testfile.txt'.

```
MMEM:DATA '\Public\User\Testfile.txt',#220Contents of the
file
```

The parameter mean:

- '\Public\...' selects the target file
- #2: hash sign and length of the length information (20 bytes = 2 digits)
- 20: indicates the number of subsequent binary data bytes
- Contents of the file: store 20 binary bytes (characters) to the file

```
MMEM:DATA? '\Public\User\Testfile.txt'
```

Transfers the contents of the file 'Testfile.txt' to the control computer.

Characteristics

*RST value: -
SCPI: conform

MMEMory:DELeTe <File>

This command deletes a file.

Parameter

<File>

String containing the path and file name of the file to delete.

Example

```
MMEM:DEL '\Public\Screen Shots\Screen0001.png'
```

Deletes the file Screen0001.png.

Characteristics

*RST value: -
SCPI: conform

MMEMory:FILE <File>

This command creates a file.

Parameter

<File>

String containing the file name.

Example

```
MMEM:FILE 'TEST.TXT'
```

Creates the file TEST.TXT

Characteristics

*RST value: -
SCPI: conform

MMEMory:FILE:DATE <FileName>,<Date>

This command sets the date of a file.

Parameter

<FileName>

String containing the path and file name.

<Date>

Numeric values indicating the date

You have to enter the date as comma separated values after the string with the file name. The sequence is year,month,day.

The available value range is 1980...2099, 1...12, 1...31

Example

```
MMEM:FILE:DATE '\Public\Screen  
Shots\Screen0001.png', 2006, 04, 01
```

Sets the date to April, 1st, 2006.

```
MMEM:FILE:DATE? '\Public\Screen Shots\Screen0001.png'
```

Returns the modification date of the file Screen0001.png.

Characteristics

*RST value: -
SCPI: conform

MMEMory:FILE:TIME <FileName>,<Time>

This command sets the time of a file. The sequence of entry is hour, minute, second.

Parameter

<FileName>

String containing the path and file name.

<Time>

Numeric values indicating the time.

You have to enter the time as comma separated values after the string with the file name. The sequence is hour,minute,second.

The available value range is 0...23, 0...59, 0...59.

Example

```
MMEM:FILE:TIME '\Public\Screen Shots\Screen0006.png',11,04,00
```

Sets the time to 11:04:00

Characteristics

*RST value: -
SCPI: conform

MMEMory:INIT

This command formats the indicated drive.

Note

Formatting deletes all data stored on the memory drive.

This command is an event and therefore has no *RST value and no query.

Example:

```
MMEM:INIT
```

Formats and deletes all data from the drive.

Characteristics:

*RST value: -
SCPI: conform

MMEMory:LOAD:STATe 1,<FileName>

This command loads the settings from a *.set file.

Parameter

<FileName>

String containing the path and file name.

Example

```
MMEM:LOAD:STAT 1, '\Public\Datasets\Dataset001.set'
```

Loads the settings from the file Dataset001.

Characteristics

*RST value: -
SCPI: conform

MMEMory:MDIRectory <Directory>

This command creates a new directory.

This command is an event and therefore has no *RST value and no query.

Parameter

<Directory>

String containing the path and new directory name.

Example

```
MMEM:MDIR '\Public\USER'
```

Creates the a directory called 'User'

Characteristics

*RST value: -
SCPI: device-specific

MMEMory:MOVE <SourceFile>,<NewFileName>

This command renames files, if <file_destination> contains no path. Otherwise the file is moved to the indicated path and stored under the file name specified there.

This command is an event and therefore has no *RST value and no query.

Parameter

<SourceFile>

String containing the path and file name of the source file.

<DestinationFile>

String containing the path and name of the destination file.

Example

```
MMEM:MOVE '\Public\Screen  
Shots\Screen0002.png', '\Public\Screen Shots\Screen0001.png'
```

Renames Screen0002.png to Screen0001.png

```
MMEM:MOVE '\Public\Screen
Shots\Screen0001.png','\Public\Test\Pic1.png'
Moves file Screen0006.png to the 'Test' folder and renames the file Pic1.png
```

Characteristics

*RST value: -
SCPI: conform

MMEMory:RDIRectory <Directory>

This command deletes the indicated directory. The directory name includes the path and may also include the drive name. The path name complies with DOS conventions.

This command is an event and therefore has no *RST value and no query.

Parameter

<Directory>
String containing the path of the directory to delete.

Example

```
MMEM:RDIR '\Public\Screen Shots\
Deletes the directory 'Screen Shots'.
```

Characteristics

*RST value: -
SCPI: device-specific

MMEMory:STORe:STATe 1,<FileName>

This command stores the current device settings in a *set file.

This command is an event and therefore has no *RST value and no query.

Parameter

1,<FileName>
String containing the path and name of the destination file.

Example

```
MMEM:STOR:STAT 1, 'DATASET001.SET'
Saves the current device settings in the file DATASET001.SET.
```

Characteristics

*RST value: -
SCPI: conform

SYSTem:SET:LOCK <FileName>

This command adds write-protection to a dataset.

Parameter

<FileName>

String containing the path and name of the dataset.

Example

```
SYST:SET:LOCK 'Dataset001.set'
```

Protects the file Dataset001.set from overwriting.

Characteristics

*RST value: -

SCPI: device-specific

SYSTem:SET:UNLock <FileName>

This command removes write-protection from a dataset.

Parameter

<FileName>

String containing the path and name of the dataset.

Example

```
SYST:SET:UNL 'Dataset001.set'
```

Removes write-protection from the file Dataset001.set.

Characteristics

*RST value: -

SCPI: device-specific

7.9 Making and Storing Screenshots

The following commands manage screenshots.

These commands are independent from the operating mode.

List of commands

- [DISPlay:WINDow:STORe](#) (p. 287)
- [HCOPy:DEVice:LANGuage](#) (p. 287)
- [HCOPy\[:IMMEDIATE\]](#) (p. 288)
- [MMEMory:NAME <FileName>](#) (p. 288)

DISPlay:WINDow:STORe

This command makes a screenshot of the current display contents in png or jpg format and stores it on the R&S FSH internal memory.

You can select a file name for the screenshot in png format with [MMEMory:NAME <FileName>](#) and select the file format of the screenshot with [HCOPy:DEVice:LANGuage](#).

This command is an event and therefore has no *RST value and no query.

Example

```
HCOP:DEV:LANG PNG
MMEM:NAME '\Public\Screen Shots\Test.png'
DISP:WIND:STOR
```

Makes and stores a screenshot of the current screen in a file 'Test.png'.

Characteristics

*RST value: -
SCPI: device-specific

HCOPy:DEVice:LANGuage

This command selects the file format for screenshots.

Parameter

PNG | JPG

Example

```
HCOP:DEV:LANG PNG
Selects the png format for screenshots.
```

Characteristics

*RST value: -
SCPI: device-specific

HCOPY[:IMMEDIATE]

This command makes a screenshot of the current display contents in png format and stores it on the R&S FSH internal memory.

You can select a file name for the screenshot in png format with `MMEMory:NAME <FileName>` and select the file format of the screenshot with `HCOPY:DEVIce:LANGUage`.

To make a screenshot in jpg format, use `DISPlay:WINDow:STORe`.

This command is an event and therefore has no *RST value and no query.

Example

```
HCOP:DEV:LANG PNG
MMEM:NAME '\Public\Screen Shots\Test.png'
HCOP
```

Makes and stores a screenshot of the current screen in a file 'Test.png'.

Characteristics

*RST value: -
SCPI: device-specific

MMEMory:NAME <FileName>

This command defines the path and file name that the R&S FSH uses for storing screenshots (see `HCOPY[:IMMEDIATE]`). The path and file name comply with DOS conventions.

This command is an event and therefore has no *RST value and no query.

Parameter

<FileName>
String containing the file name.

Example

```
MMEM:NAME 'Public\Screenshots\Test.png'
```

Stores the screenshot on the in the corresponding directory on the R&S FSH.

Characteristics

*RST value: -
SCPI: device-specific

7.10 Configuring Data Capture

The following commands configure the data capture.

These commands are independent from the operating mode.

List of commands

- [SYSTem:CAPTure:COUNter <Counter>](#) (p. 289)
- [SYSTem:CAPTure:DATaset\[:STATe\] <State>](#) (p. 289)
- [SYSTem:CAPTure:GPX\[:STATe\] <State>](#) (p. 290)
- [SYSTem:CAPTure:SCReen\[:STATe\] <State>](#) (p. 290)

SYSTem:CAPTure:COUNter <Counter>

This command defines the start of the file name counter.

The counter numbers the files stored when you capture data (screenshots, datasets etc.).

Parameter

<Counter>

String containing the number with which to start numbering files.

Example

```
SYST:CAPT:COUN '0100'
```

Starts numbering files with 0100, e.g. Measurement0100.png.

Characteristics

*RST value: '0000'

SCPI: device-specific

SYSTem:CAPTure:DATaset[:STATe] <State>

This command includes or excludes datasets from the data capture.

Parameter

<State>

ON | OFF

Example

```
SYST:CAPT:DAT ON
```

Includes datasets into the data capture

Characteristics

*RST value: OFF

SCPI: device-specific

SYSTem:CAPTure:GPX[:STATe] <State>

This command includes or excludes GPX information from the data capture.

Parameter

<State>
ON | OFF

Example

```
SYST:CAPT:GPX ON
```

Includes GPX information into the data capture

Characteristics

*RST value: OFF
SCPI: device-specific

SYSTem:CAPTure:SCReen[:STATe] <State>

This command includes or excludes screenshots from the data capture.

Parameter

<State>
ON | OFF

Example

```
SYST:CAPT:SCR ON
```

Includes screenshots into the data capture

Characteristics

*RST value: ON
SCPI: device-specific

7.11 Saving Events

The following commands configure the circumstances under which the R&S FSH saves events.

These commands are independent from the operating mode.

Using the commands requires an GPS receiver and a storage device (SD card or memory stick).

List of commands

- [SYSTem:SOEVent:DIStance:INTerval <Distance>](#) (p. 291)
- [SYSTem:SOEVent:LIMits:MODE <Mode>](#) (p. 291)
- [SYSTem:SOEVent:RECOrding:STORage <Device>](#) (p. 292)
- [SYSTem:SOEVent:SOURce <EventType>](#) (p. 292)
- [SYSTem:SOEVent:TIME:INTerval <Time>](#) (p. 293)
- [SYSTem:SOEVent\[:STATe\] <State>](#) (p. 293)

SYSTem:SOEVent:DIStance:INTerval <Distance>

This command defines a distance that you must cover before the R&S FSH saves another coordinate.

Parameter

<Distance>

Distance between one coordinate and the next.

Example

```
SYST:SOEV ON
```

Turns on saving coordinates on an event.

```
SYST:SOEV:REC:STOR USB
```

Selects an USB device as the storage device.

```
SYST:SOEV:SOUR DIST
```

```
SYST:SOEV:DISt:INT 5
```

Saves the coordinates every 5 m.

Characteristics

*RST value: 1 m

SCPI: device-specific

SYSTem:SOEVent:LIMits:MODE <Mode>

This command selects the limit check condition that must occur in order to save a coordinate.

Parameter

<Mode>

FAILonly	Saves only sweeps that contain a limit check violation.
STARtonfail	Starts to save all sweeps from the moment a limit check fails.
STOPonfail	Saves all sweeps until a limit check fails.

Example

```
SYST:SOEV:SOUR LIM
```

```
SYST:SOEV:LIM:MODE FAIL
```

Saves all sweeps that contain a violation of a limit check.

Characteristics

*RST value: STAR

SCPI: device-specific

SYSTem:SOEVent:RECOrding:STORage <Device>

This command selects the storage device to save the coordinates to.

Parameter

<Device>

SDCard	Saves coordinates to an SD card.
USB	Saves coordinates to an USB device.

Example

See [SYSTem:SOEVent:DIStance:INTerval <Distance>](#).

Characteristics

*RST value: SDCard

SCPI: device-specific

SYSTem:SOEVent:SOURce <EventType>

This command selects the type of event that triggers saving the coordinates of your current location.

Parameter

<EventType>

ALLSweeps	Saves coordinates after each sweep.
DIStanceint	Saves coordinates after a certain distance has been covered.
LIMitsfail	Saves coordinates when a limit check has failed.
TI梅interval	Saves coordinates after a certain length of time has passed.

Example

See [SYSTem:SOEVent:DIStance:INTerval <Distance>](#).

Characteristics

*RST value: TIMEinterval
SCPI: device-specific

SYSTem:SOEVent:TIME:INTerval <Time>

This command defines a time interval that must pass before the R&S FSH saves another coordinate.

Parameter

<Time>

Time that must pass between one coordinate and the next.

Example

```
SYST:SOEV ON  
Turns on saving coordinates on an event.
```

```
SYST:SOEV:REC:STOR USB  
Selects an USB device as the storage device.
```

```
SYST:SOEV:SOUR TIM  
SYST:SOEV:TIME:INT 5  
Saves the coordinates every 5 seconds.
```

Characteristics

*RST value: 1 s
SCPI: device-specific

SYSTem:SOEVent[:STATE] <State>

This command turns saving of your current coordinates in case of certain events on and off.

Parameter

<State>

ON | OFF

Example

See [SYSTem:SOEVent:DISTance:INTerval <Distance>](#).

Characteristics

*RST value: OFF
SCPI: device-specific

7.12 Configuring the Instrument

The following commands configure general instrument settings.

These commands are independent from the operating mode.

Contents

[Mode Selection](#) on page 294

[Controlling the GPS Receiver](#) on page 296

[Display Configuration](#) on page 303

[Audio Settings](#) on page 305

[Setting up a Network Connection](#) on page 307

[System Settings](#) on page 310

7.12.1 Mode Selection

This chapter describes all commands that select the operating mode of the R&S FSH.

List of commands

- [INSTrument\[:SElect\] <OperatingMode>](#) (p. 294)
- [INSTrument:NSElect <OperatingMode>](#) (p. 295)

INSTrument[:SElect] <OperatingMode>

This command selects the operating mode.

Parameter

<OperatingMode>

DTF	distance-to-fault
GEOTagging	geotagging
IANalyzer	interference analyzer
NAN	network analyzer
PM	power meter
RECeiver	receiver
SANalyzer	spectrum analyzer
GSM	digital modulation: GSM
BTDScdma	digital modulation: TD-SCDMA
BWCDpower	digital modulation: WCDMA
C2K	digital modulation: CDMA2000
BDO	digital modulation: 1xEV-DO
LTEFdd	digital modulation: LTE FDD
LTETdd	digital modulation: LTE TDD
NIOT	digital modulation: NB-IoT

Example

```
INST SAN
```

Selects spectrum analyzer mode.

Characteristics

*RST value: ACT

SCPI: conform

INSTrument:NSElect <OperatingMode>

This command selects the operating mode.

Parameter

1	spectrum analyzer
2	network analyzer
4	distance-to-fault
5	power meter
6	receiver
7	digital modulation: WCDMA
8	digital modulation: CDMA2000
9	digital modulation: 1xEV-DO
10	digital modulation: LTE FDD
11	digital modulation: LTE TDD
12	digital modulation: TD-SCDMA
15	digital modulation: GSM
16	interference analyzer
17	geotagging
18	digital modulation: NB-IoT

Example

```
INST:NSEL 1
```

Selects spectrum analyzer mode.

Characteristics

*RST value: 11

SCPI: conform

7.12.2 Controlling the GPS Receiver

This chapter describes all commands that control the GPS receiver.

List of commands

- [SYSTem:POSition:ALTitude?](#) (p. 296)
- [SYSTem:POSition:COMPass:ANGLE?](#) (p. 296)
- [SYSTem:POSition:COMPass\[:STATe\] <State>](#) (p. 297)
- [SYSTem:POSition:COMPass:VALid?](#) (p. 297)
- [SYSTem:POSition:GPS\[:STATe\] <State>](#) (p. 297)
- [SYSTem:POSition:GPS:CONNected?](#) (p. 298)
- [SYSTem:POSition:GPS:CORRection:FREQuency?](#) (p. 298)
- [SYSTem:POSition:GPS:QUALity](#) (p. 298)
- [SYSTem:POSition:GPS:SATellites?](#) (p. 299)
- [SYSTem:POSition:LATitude?](#) (p. 299)
- [SYSTem:POSition:LONGitude?](#) (p. 300)
- [SYSTem:POSition:VALid?](#) (p. 300)

SYSTem:POSition:ALTitude?

This command queries the altitude of the current position of the R&S FSH.

Return value

<Altitude>

Altitude in meters above sea level.

If the GPS receiver is inactive, this query returns 0.

Example

```
SYST:POS:ALT?
```

Return value would be, for example, 554.1

Characteristics:

*RST value: -

SCPI: device-specific

SYSTem:POSition:COMPass:ANGLE?

This command queries the compass information of your position.

Return value

<Angle>

Angle to magnetic north in degrees.

If the GPS receiver is inactive, this query returns 0.

Example

```
SYST:POS:COMP:ANGL?
```

Return value would be, for example, 90

Characteristics:

*RST value: -
SCPI: device-specific

SYSTem:POStion:COMPAss[:STATe] <State>

This command turns the compass on and off.

Parameter

<State>
ON | OFF

Example

```
SYST:POS:COMP ON
```

Turns on the compass.

Characteristics:

*RST value: OFF
SCPI: device-specific

SYSTem:POStion:COMPAss:VALid?

This command queries the validity of the compass information.

Example

```
SYST:POS:COMP:VAL?
```

Returns if the compass information is valid.

Characteristics:

*RST value: -
SCPI: device-specific

SYSTem:POStion:GPS[:STATe] <State>

This command turns the GPS receiver (R&S HA-Z240) on and off.

Note that the GPS receiver only works if a connection between the R&S FSH and a GPS signal transmitter is established.

Parameter

<State>
ON | OFF

Example

```
SYST:POS:GPS ON
```

Activates the GPS receiver.

Characteristics:

*RST value: OFF
SCPI: device-specific

SYSTem:POSition:GPS:CONNected?

This command queries if the R&S FSH is currently connected to the GPS receiver.

Return values

0	No connection to a satellite.
1	Connection to a satellite established.

Example

```
SYST:POS:GPS:CONN?
```

Characteristics:

*RST value: -
SCPI: device-specific

SYSTem:POSition:GPS:CORRection:FREQuency?

This command queries the frequency correction factor.

The R&S FSH calculates this factor from a reference signal provided by the GPS receiver R&S HA-Z240. The reference signal is used to determine the deviation of the internal clock of the instrument. The deviation can be turned into a correction factor for the measured frequency.

Return values

<floating point value>

If the GPS receiver is inactive, this query returns 0.

Example

```
SYST:POS:GPS:CORR:FREQ?
```

Queries the frequency correction factor.

Characteristics:

*RST value: -
SCPI: device-specific

SYSTem:POSition:GPS:QUALity?

This command queries the quality of the GPS signal.

Return values

INSufficient | LOW | MEDium | HIGH | EXCellent

Example

```
SYST:POS:GPS:QUAL?
```

Characteristics:

*RST value: -
SCPI: device-specific

SYSTem:POSition:GPS:SATellites?

This command queries the number of tracked satellites.

Return values

<number of satellites>

Example

```
SYST:POS:GPS:SAT?
```

Characteristics:

*RST value: -

SCPI: device-specific

SYSTem:POSition:LATitude?

This command queries the latitude of the current position of the R&S FSH.

Return values

<sign><degrees>,<minutes>,<seconds>

<sign>	No sign = northern hemisphere Negative sign (-) = southern hemisphere
<degrees>	Degrees of latitude (integer value)
<minutes>	Minutes of latitude (integer value)
<seconds>	Seconds of latitude (floating point value)

Example

```
SYST:POS:LAT?
```

Return value would be, for example, 48,7,40.0 for 48°, 7', 40.0" in the northern hemisphere.

Characteristics:

*RST value: -

SCPI: device-specific

SYSTem:POSition:LONGitude?

This command queries the longitude of the current position of the R&S FSH.

Return values

<sign><degrees>,<minutes>,<seconds>

<sign>	No sign = east Negative sign (-) = west
<degrees>	Degrees of longitude (integer value)
<minutes>	Minutes of longitude (integer value)
<seconds>	Seconds of longitude (floating point number)

Example

SYST:POS:LONG?

Return value would be, for example, 11,36,46.2 for 11°, 36', 46.2" East

Characteristics:

*RST value: -
SCPI: device-specific

SYSTem:POSition:VALid?

This command queries if the current position is valid.

Return values

0	GPS position is not valid.
1	GPS position is valid.

Example

SYST:POS:VAL?

Characteristics:

*RST value: -
SCPI: device-specific

7.12.3 Controlling a Precision Frequency Reference (R&S FSH-Z114)

This chapter describes commands to query the characteristics of a connected precision frequency reference.

List of Commands

- [SYSTem:FREQuency:REFerence:CONNected?](#) (p. 301)
- [SYSTem:FREQuency:REFerence:LOCKed?](#) (p. 301)
- [SYSTem:FREQuency:REFerence:CORRection:FREQuency?](#) (p. 302)

SYSTem:FREQuency:REFerence:CONNected?

This command queries if a precision frequency reference is connected.

Return values

0	Precision frequency reference is not detected.
1	Precision frequency reference is detected.

Example

```
SYST:FREQ:REF:CONN?
```

Queries the connections state.

Characteristics:

*RST value: -

SCPI: device-specific

SYSTem:FREQuency:REFerence:LOCKed?

This command queries if the precision frequency reference is locked.

Return values

0	GPS position is not locked.
1	GPS position is locked.

Example

```
SYST:FREQ:REF:LOCK?
```

Queries the locked state.

Characteristics:

*RST value: -

SCPI: device-specific

SYSTem:FREQuency:REFerence:CORRection:FREQuency?

This command queries the frequency correction factor.

Return values

Frequency in Hz.

Example

```
SYST:FREQ:REF:CORR:FREQ?
```

Queries the correction factor

Characteristics:

*RST value: -

SCPI: device-specific

7.12.4 Display Configuration

This chapter describes commands to set up the display of the R&S FSH via remote control.

List of Commands

- [DISPlay:BRIGhtness <Brightness>](#) (p. 303)
- [DISPlay:CMAp <ColorScheme>](#) (p. 303)
- [DISPlay:CMAp:DEFault](#) (p. 304)
- [DISPlay:DATE:FORMat <DateFormat>](#) (p. 304)

DISPlay:BRIGhtness <Brightness>

This command sets the brightness of the display backlight.

Parameter

<Brightness>

Numeric value in the range from 0 to 1

Example

```
DISP:BRIG 0.80
```

Sets the brightness of the display to 80%

Characteristics

*RST value: 0.5 (50%)

SCPI: device-specific

DISPlay:CMAp <ColorScheme>

This command sets the color scheme of the display.

Parameter

<ColorScheme>

COLor	Color.
BW	Black & white.
PF	Printer friendly.

Example

```
DISP:CMAp BW
```

Sets the screen colors to black and white

Characteristics

*RST value: COLor

SCPI: conform

DISPlay:CMAP:DEFault

This command sets the display to the default state.

This command is an event and therefore has no query and no *RST value.

Example

```
DISP:CMAP:DEF
```

Restores the original color scheme

Characteristics

*RST value: -

SCPI: conform

DISPlay:DATE:FORMat <DateFormat>

This command sets the display date format.

Parameter

<DateFormat>

DDMMyyyy | MMDDyyyy

Example

```
DISP:DATE:FORM DDMMyyyy
```

Characteristics

*RST value: DDMMyyyy

SCPI: device-specific

7.12.5 Audio Settings

This chapter describes all commands to control the audio functions of the R&S FSH.

List of commands

- [SYSTem:AUDio:VOLume <Volume>](#) (p. 305)
- [SYSTem:BEEPer:VOLume <Volume>](#) (p. 305)
- [SYSTem:BEEPer:KEY:VOLume <Volume>](#) (p. 306)

SYSTem:AUDio:VOLume <Volume>

This command sets the volume of the internal speaker.

Parameter

<Volume>

Numeric value in the range from 0 to 1

Example

```
SYST:AUD:VOL 0.40  
Sets the volume to 40%
```

Characteristics

*RST value: 0.3 (30%)
SCPI: device-specific

SYSTem:BEEPer:VOLume <Volume>

This command sets the volume of the system beeper.

Parameter

<Volume>

Numeric value in the range from 0 to 1

Example

```
SYST:BEEP:VOL 0.50  
Sets the volume of the beeper to 50%
```

Characteristics

*RST value: 0.6 (60%)
SCPI: conform

SYSTem:BEEPer:KEY:VOLume <Volume>

This command sets the volume of the keyboard click noise.

Parameter

<Volume>

Numeric value in the range from 0 to 1

Example

```
SYST:BEEP:KEY:VOL 0.10
```

Sets of keyboard clicking volume to 10%

Characteristics

*RST value: 0.3 (30%)

SCPI: conform

7.12.6 Setting up a Network Connection

This chapter describes all commands that are used if the R&S FSH is part of a network.

List of commands

- [SYSTem:COMMunicate:LAN:ETHernet?](#) (p. 307)
- [SYSTem:COMMunicate:LAN:GATeway <Gateway>](#) (p. 307)
- [SYSTem:COMMunicate:LAN:SUBMask <SubnetMask>](#) (p. 308)
- [SYSTem:COMMunicate:SOCKet:ADDRess <IPAddress>](#) (p. 308)
- [SYSTem:COMMunicate:SOCKet:DHCP\[:STATe\] <State>](#) (p. 308)
- [SYSTem:COMMunicate:SOCKet:PORT <Port>](#) (p. 309)

SYSTem:COMMunicate:LAN:ETHernet?

This command queries the MAC address of the R&S FSH.

This command is a query and therefore has no *RST value.

Example

```
SYST:COMM:LAN:ETH?  
Returns the MAC address
```

Characteristics

*RST value: -
SCPI: device-specific

SYSTem:COMMunicate:LAN:GATeway <Gateway>

This command sets the gateway in the LAN.

Parameter

<Gateway>
String containing the identifier of the gateway.

Characteristics

*RST value: -
SCPI: device-specific

SYSTem:COMMunicate:LAN:SUBMask <SubnetMask>

This command sets the subnet mask of the R&S FSH.

Parameter

<SubnetMask>

String containing the subnet mask ('x.x.x.x').

Example

```
SYST:COMM:LAN:SUBM '255.255.255.0'
```

Sets the subnet mask address to 255.255.255.0

Characteristics

*RST value: 255.255.255.0
SCPI: device-specific

SYSTem:COMMunicate:SOCKet:ADDRess <IPAddress>

This command sets the IP address of the R&S FSH.

Parameter

<IPAddress>

String containing the IP address ('x.x.x.x').

Example

```
SYST:COMM:SOCK:ADDR '172.76.68.30'
```

Sets the IP address of the R&S FSH to 172.76.68.30

Characteristics

*RST value: 172.76.68.24
SCPI: device-specific

SYSTem:COMMunicate:SOCKet:DHCP[:STATe] <State>

This command turns the Dynamic Host Configuration Protocol (DHCP) on and off.

Parameter

<State>

ON | OFF

Example

```
SYST:COMM:SOCK:DHCP ON
```

Activates DHCP.

Characteristics

*RST value: ON
SCPI: device-specific

SYSTem:COMMunicate:SOCKet:PORT <Port>

This command sets the port number for the connection.

Parameter

<Port>
Port number

Example

```
SYST:COMM:SOCK:PORT 1000
```

Sets the port number to 1000

Characteristics

*RST value: 5555
SCPI: device-specific

7.12.7 System Settings

This chapter describes all commands that define or query general system settings.

List of commands

- [INPut:IMPedance:PAD <MatchingPad>](#) (p. 310)
- [\[SENSe:\]ROSCilator:SOURce <RefSource>](#) (p. 311)
- [SYSTem:ACCessory?](#) (p. 311)
- [SYSTem:ACCessory:AUTO <State>](#) (p. 311)
- [SYSTem:BNC<1...2>:MODE <BNCFunction>](#) (p. 312)
- [SYSTem:DATE <Date>](#) (p. 312)
- [SYSTem:ERRor\[:NEXT\]?](#) (p. 313)
- [SYSTem:ERRor:ALL?](#) (p. 313)
- [SYSTem:ERRor:COUNT?](#) (p. 314)
- [SYSTem:ERRor:CODE\[:NEXT\]?](#) (p. 314)
- [SYSTem:ERRor:CODE:ALL?](#) (p. 314)
- [SYSTem:FORMat:IDENT <IDNFormat>](#) (p. 315)
- [SYSTem:HELP:HEADers?](#) (p. 315)
- [SYSTem:HELP:SYNTax?](#) (p. 316)
- [SYSTem:LANGuage:CATalog?](#) (p. 316)
- [SYSTem:POWER:SOURce?](#) (p. 317)
- [SYSTem:POWER:STATus?](#) (p. 317)
- [SYSTem:PRESet](#) (p. 317)
- [SYSTem:PRESet:FACTory](#) (p. 318)
- [SYSTem:PRESet:MODE <Mode>](#) (p. 318)
- [SYSTem:PRESet:USER <Preset>](#) (p. 318)
- [SYSTem:REBoot](#) (p. 319)
- [SYSTem:SHUTdown](#) (p. 319)
- [SYSTem:TIME <Time>](#) (p. 319)
- [SYSTem:TZONee <TimeShift>](#) (p. 320)
- [SYSTem:VERSion?](#) (p. 320)

INPut:IMPedance:PAD <MatchingPad>

This command selects the matching pad connected to the R&S FSH.

Parameter

<MatchingPad>
RAM | RAZ | HZTE

Example

```
INPut:IMP 75;PAD RAZ
```

Selects 75 Ω input impedance and the R&S RAZ as the matching pad.

Characteristics

*RST value: -
SCPI: device-specific

[SENSe:]ROSCillator:SOURce <RefSource>

This command selects the source of the frequency reference oscillator.

If you use an external reference signal, make sure to connect the signal to the Ext Ref BNC connector of the R&S FSH.

Parameter

<RefSource>

INTernal	Internal reference.
EXTernal	External reference.

Example

```
ROSC:SOUR EXT
```

Activates external source as reference signal.

Characteristics

*RST value: -

SCPI: device-specific

SYSTem:ACCEssory?

This command queries the type of measurement accessory, if one is connected to the R&S FSH (for example an isotropic antenna or power sensor).

Return value

Name of the accessory.

Example

```
SYST:ACC?
```

Queries connected measurement accessories.

Characteristics

*RST value: -

SCPI: device-specific

SYSTem:ACCEssory:AUTO <State>

This command turns automatic detection of connected measurement accessories on and off.

Parameter

<State>

ON | OFF

Example

```
SYST:ACC:AUTO ON
```

Turns on automatic accessory detection.

Characteristics

*RST value: -
 SCPI: device-specific

SYSTem:BNC<1...2>:MODE <BNCFunction>

This command configures the BNC sockets.

The numeric suffix at BNC selects the BNC socket you want to configure.

Parameter

<BNCFunction>

REFerence	Input for external reference signal (BNC 1)
TRIGger	Input for external trigger (BNC 1)
BIAS	BIAS port (BNC1 and BNC 2)
IF3	IF output (BNC 2)

Example

```
SYST:BNC2:MODE TRIG
```

Sets the seconds BNC socket to trigger input.

Characteristics

*RST value: BNC 1: TRIGger, BNC 2: IF3
 SCPI: device-specific

SYSTem:DATE <Date>

This command sets the date for the internal calendar.

Parameter

<Date>

Numeric value indicating the date

You have to enter the date as comma separated values after the string with the file name. The sequence is year,month,day.

The available value range is 1980...2099, 1...12, 1...31

Example

```
SYST:DATE 2000,6,1
```

Sets the date to 1/6/2000

Characteristics

*RST value: -
 SCPI: conform

SYSTem:ERRor[:NEXT]?

This command queries the oldest entry in the error queue and deletes it.

This command is a query and therefore has no *RST value.

Return value

<error number>,<error description>

<error number>	Number that contains information about the error. Negative number: error as defined in the SCPI standard. Positive number: error that is specific to the R&S FSH.
----------------	---

<error description>	String containing a short error description.
---------------------	--

If the error queue is empty, the command returns 0,'no error'.

Example

```
STAT:ERR?
```

Characteristics

*RST value: -
SCPI: conform

SYSTem:ERRor:ALL?

This command queries the complete error queue.

This command is a query and therefore no *RST value.

Return value

<error number>,<error description>

<error number>	Number that contains information about the error. Negative number: error as defined in the SCPI standard. Positive number: error that is specific to the R&S FSH.
----------------	---

<error description>	String containing a short error description.
---------------------	--

The number of values depends on the length of the queue.

If the error queue is empty, the command returns 0,'no error'.

Example

```
SYST:ERR:ALL?
```

Characteristics

*RST value: -
SCPI: device-specific

SYSTem:ERRor:CODE[:NEXT]?

This command queries the code of the next error in the error queue.

This command is a query and therefore has no *RST value.

Return value

<error number>

number that contains information about the error

Negative number: error as defined in the SCPI standard

Positive number: error that is specific to the R&S FSH

If the error queue is empty, the command returns 0.

Example

```
STAT:ERR:CODE?
```

Characteristics

*RST value: -

SCPI: conform

SYSTem:ERRor:CODE:ALL?

This command queries the complete error queue.

This command is a query and therefore no *RST value.

Return value

<error number>

number that contains information about the error

Negative number: error as defined in the SCPI standard

Positive number: error that is specific to the R&S FSH

The number of values depends on the length of the queue.

If the error queue is empty, the command returns 0,'no error'.

Example

```
SYST:ERR:CODE:ALL?
```

Characteristics

*RST value: -

SCPI: device-specific

SYSTem:ERRor:COUNt?

This command queries the number of errors currently in the error queue.

This command is a query and therefore no *RST value.

Return value

<numeric_value>

number of the errors in the queue

Example

```
SYST:ERR:COUN?
```

Characteristics

*RST value: -
SCPI: device-specific

SYSTem:FORMat:IDENt <IDNFormat>

This command sets the response format to the *IDN? query. This function is intended for re-use of existing control programs together with the R&S FSH.

Parameter

<IDNFormat>

LEGacy	Format that is compatible to R&S FSH3/6/18.
NEW	Format for R&S FSH4/8.

Example

```
SYST:FORM:IDEN LEG
```

```
*IDN?
```

IDN would return, e.g. "Rohde&Schwarz,FSH8,101805/028,1.40"

```
SYST:FORM:IDEN NEW
```

```
*IDN?
```

IDN would return, e.g. "Rohde&Schwarz,FSH8, 1309.6000K28/101805,1.40"

Characteristics

*RST value: -
SCPI: device-specific

SYSTem:HELP:HEADers?

This command returns a list of all available remote control commands.

This command is a query and therefore no *RST value.

Example

```
SYST:HELP:HEAD?
```

Returns the syntax of all available commands.

Characteristics

*RST value: -
SCPI: conform

SYSTem:HELP:SYNTax?

This command returns the full syntax of the specified command.

This command is a query and therefore no *RST value.

Parameter

<Command>

String containing the command you want to query

Example

```
SYST:HELP:SYNT? 'SYST:ERR?'
```

Returns the full syntax. In this case: 'SYSTem:ERRor[:NEXT]'.

Characteristics

*RST value: -

SCPI: device-specific

SYSTem:LANGUage <Language>

This command sets the language of the R&S FSH user interface. You can query a list of available languages with `SYSTem:LANGUage:CATalog?`.

Parameter

<Language>

string containing the language

Example

```
SYST:LANG 'english'
```

Sets the system language to English

Characteristics

*RST value: -

SCPI: conform

SYSTem:LANGUage:CATalog?

This command lists all languages available for the user interface.

This command is a query and therefore no *RST value.

Example

```
SYST:LANG:CAT?
```

Queries available languages.

Characteristics

*RST value: -

SCPI: device-specific

SYSTem:POWer:SOURce?

This command queries the current R&S FSH power source.

This command is a query and therefore has no *RST value.

Return values

ADAP	R&S FSH is powered by the AC power supply.
BATT	R&S FSH is powered by the battery.

Example

```
SYST:POW:SOUR?
```

Queries current power source.

Characteristics

*RST value: -

SCPI: conform

SYSTem:POWer:STATus?

This command queries the remaining power of the battery.

This command is a query and therefore has no *RST value.

Return values

Numeric value in the range from 0 to 100 %.

Example

```
SYST:POW:STAT?
```

Checks remaining battery power.

Characteristics

*RST value: -

SCPI: conform

SYSTem:PRESet

Resets the R&S FSH to its default state or a state defined by the user, depending on SYSTem:PRESet:MODE.

This command is an event and therefore has no *RST value and no query.

Example

```
SYST:PRES
```

Presets the instrument.

Characteristics

*RST value: -

SCPI: conform

SYSTem:PRESet:FACTory

This command initiates an instrument reset back to factory settings.

This command is an event and therefore has no query and no *RST value.

Example

```
SYST:PRESet:FACT
```

Resets the R&S FSH to its factory settings.

Characteristics

*RST value: -

SCPI: device-specific

SYSTem:PRESet:MODE <Mode>

This command selects the preset mode.

Parameter

<Mode>

DEFault	Default preset state.
USER	User defined preset state.

Example

```
SYST:PRESet:MODE USER
```

Selects a user defined preset.

Characteristics

*RST value: -

SCPI: conform

SYSTem:PRESet:USER <Preset>

This command selects a file containing a user defined preset state.

Parameter

<Preset>

filename of the user defined preset state

Characteristics

*RST value: -

SCPI: conform

SYSTem:REBoot

This command initiates a reboot of the R&S FSH.

This command is an event and therefore has no *RST value and no query.

Example

```
SYST:REB  
Restarts the R&S FSH.
```

Characteristics

*RST value: -
SCPI: conform

SYSTem:SHUTdown

This command turns the R&S FSH off.

This command is an event and therefore has no *RST value and no query.

Example

```
SYST:SHUT  
Turns the R&S FSH off.
```

Characteristics

*RST value: -
SCPI: conform

SYSTem:TIME <Time>

This command sets the internal clock.

Parameter

<Time>
Numeric value indicating the time

You have to enter the time as comma separated values after the string with the file name. The sequence is hour,minute,second.

The available value range is 0...23, 0...59, 0...59.

Example

```
SYST:TIME 12,30,30
```

Characteristics

*RST value: -
SCPI: conform

SYSTem:TZONee <TimeShift>

This command defines a shift of the system time to select another time zone.

Parameter

<TimeShift>

Numeric value indicating the time shift.

You have to enter the time shift as comma separated value. The sequence is hour,minute.

The available value range is 0...23, 0...59.

Example

```
SYST:TZON 01,00
```

Shifts the time an hour ahead

Characteristics

*RST value: 0,0

SCPI: device-specific

SYSTem:VERSion?

This command queries the SCPI version the remote control is based on.

This command is a query and therefore has no *RST value.

Return value

1999.0

Example

```
SYST:VERS?
```

Characteristics

*RST value: -

SCPI: conform

7.13 Status Reporting System

The status reporting system stores all information on the present operating state of the instrument, and on errors which have occurred. This information is stored in the status registers and in the error queue. The status registers and the error queue can be queried via Ethernet.

The information is of a hierarchical structure. The register status byte (STB) defined in IEEE 488.2 and its associated mask register service request enable (SRE) form the uppermost level. The STB receives its information from the standard event status register (ESR) which is also defined in IEEE 488.2 with the associated mask register standard event status enable (ESE) and registers STATus:OPERation and STATus:QUESTIONable which are defined by SCPI and contain detailed information on the instrument.

The output buffer contains the messages the instrument returns to the controller. It is not part of the status reporting system but determines the value of the MAV bit in the STB.

7.13.1 Structure of an SCPI Status Register

Each standard SCPI register consists of 5 parts which each have a width of 16 bits and have different functions. The individual bits are independent of each other, i.e. each hardware status is assigned a bit number that applies to all five parts. For example, bit 0 of the STATus:OPERation register is assigned to the calibration status of the R&S FSH. Bit 15 (the most significant bit) is set to zero for all parts. Thus the contents of the register parts can be processed by the controller as positive integer.

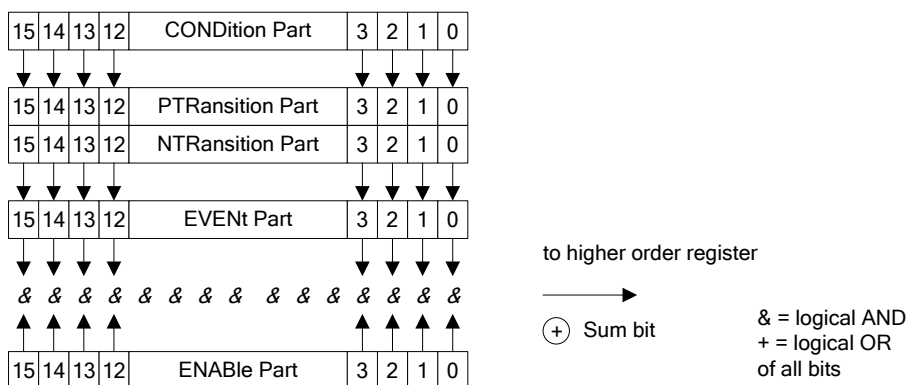

Figure 7-1: The status-register model

7.13.1.1 CONDition part

The CONDition part is directly written into by the hardware or the sum bit of the next lower register. Its contents reflects the current instrument status. This register part can only be read, but not written into or cleared. Its contents is not affected by reading.

7.13.1.2 PTRansition part

The Positive-TRansition part acts as an edge detector. When a bit of the CONDition part is changed from 0 to 1, the associated PTR bit decides whether the EVENT bit is set to 1.

PTR bit =1: the EVENT bit is set.

PTR bit =0: the EVENT bit is not set.

This part can be written into and read at will. Its contents is not affected by reading.

7.13.1.3 NTRansition part

The Negative-TRansition part also acts as an edge detector. When a bit of the CONDition part is changed from 1 to 0, the associated NTR bit decides whether the EVENT bit is set to 1.

NTR-Bit = 1: the EVENT bit is set.

NTR-Bit = 0: the EVENT bit is not set.

This part can be written into and read at will. Its contents is not affected by reading.

With these two edge register parts the user can define which state transition of the condition part (none, 0 to 1, 1 to 0 or both) is stored in the EVENT part.

7.13.1.4 EVENT part

The EVENT part indicates whether an event has occurred since the last reading, it is the "memory" of the condition part. It only indicates events passed on by the edge filters. It is permanently updated by the instrument. This part can only be read by the user. Reading the register clears it. This part is often equated with the entire register.

7.13.1.5 ENABLE part

The ENABLE part determines whether the associated EVENT bit contributes to the sum bit (see below). Each bit of the EVENT part is ANDed with the associated ENABLE bit (symbol '&'). The results of all logical operations of this part are passed on to the sum bit via an OR function (symbol '+').

ENABLE-Bit = 0: the associated EVENT bit does not contribute to the sum bit

ENABLE-Bit = 1: if the associated EVENT bit is "1", the sum bit is set to "1" as well.

This part can be written into and read by the user at will. Its contents is not affected by reading.

7.13.1.6 Sum bit

As indicated above, the sum bit is obtained from the EVENT and ENABLE part for each register. The result is then entered into a bit of the CONDition part of the higher-order register.

The instrument automatically generates the sum bit for each register. Thus an event, e.g. a PLL that has not locked, can lead to a service request throughout all levels of the hierarchy.



The service request enable register SRE defined in IEEE 488.2 can be taken as ENABLE part of the STB if the STB is structured according to SCPI. By analogy, the ESE can be taken as the ENABLE part of the ESR.

7.13.2 Overview of the Status Register

The following figure shows the status registers used by the R&S FSH.

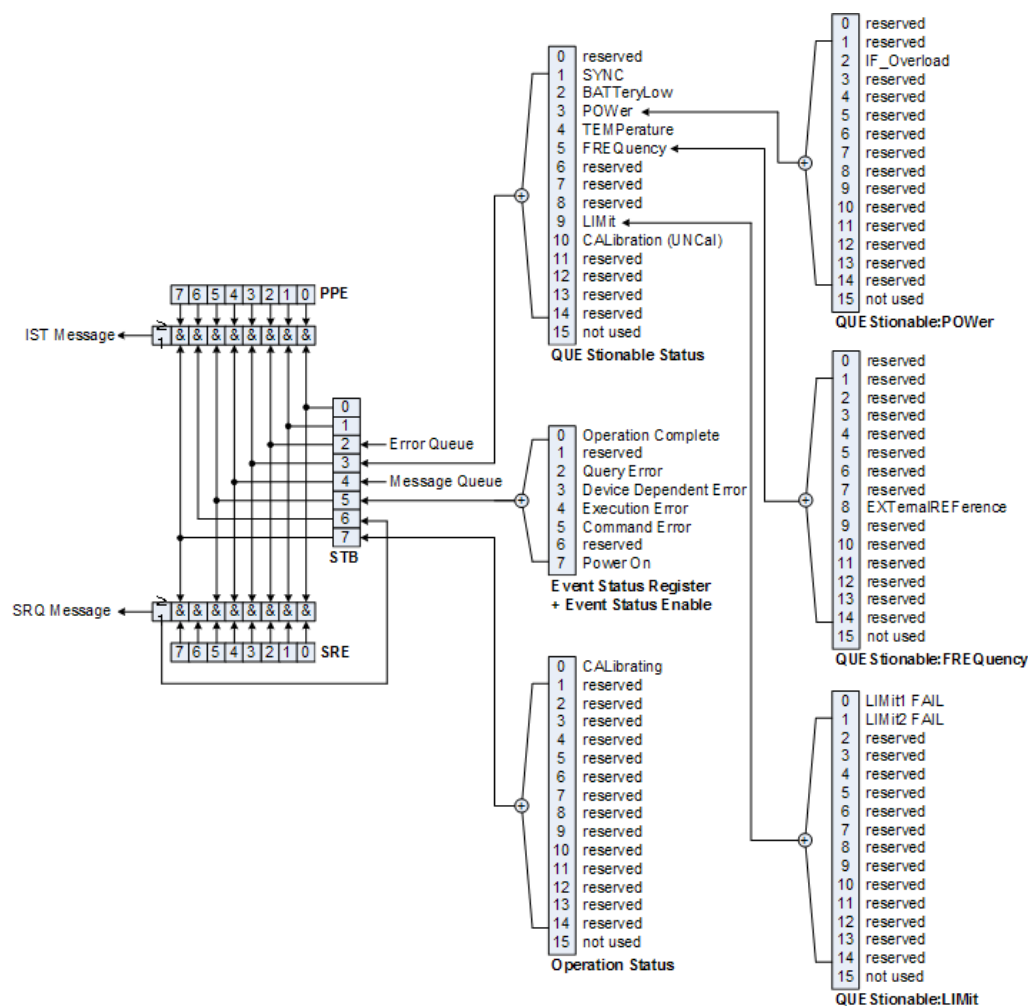

7.13.3 Status Byte (STB) & Service Request Enable Register (SRE)

The STB is already defined in IEEE 488.2. It provides a rough overview of the instrument status by collecting the pieces of information of the lower registers. It can thus be compared with the CONDition part of an SCPI register and assumes the highest level within the SCPI hierarchy. A special feature is that bit 6 acts as the sum bit of the remaining bits of the status byte.

The STATUS BYTE is read using the command "*STB?" or a serial poll.

The STB is linked to the SRE. The latter corresponds to the ENABLE part of the SCPI registers in its function. Each bit of the STB is assigned a bit in the SRE. Bit 6 of the SRE is ignored. If a bit is set in the SRE and the associated bit in the STB changes from 0 to 1, a service request (SRQ) is generated, which triggers an interrupt in the controller if this is appropriately configured and can be further processed there. The SRE can be set using the command "*SRE" and read using the command "*SRE?"

Table 7-1: Meaning of the bits used in the Status Byte

Bit No.	Meaning
0 to 1	Not used
2	<p>Error Queue not empty</p> <p>The bit is set when an entry is made in the error queue. If this bit is enabled by the SRE, each entry of the error queue generates a service request. Thus an error can be recognized and specified in greater detail by polling the error queue. The poll provides an informative error message. This procedure is to be recommended since it considerably reduces the problems involved with remote control.</p>
3	<p>QUESTionable status sum bit</p> <p>The bit is set if an EVENT bit is set in the QUESTionable: status register and the associated ENABLE bit is set to 1. A set bit indicates a questionable instrument status, which can be specified in greater detail by polling the QUESTionable status register.</p>
4	<p>MAV bit (message available)</p> <p>The bit is set if a message is available in the output buffer which can be read. This bit can be used to enable data to be automatically read from the instrument to the controller.</p>
5	<p>ESB bit</p> <p>Sum bit of the event status register. It is set if one of the bits in the event status register is set and enabled in the event status enable register. Setting of this bit indicates a serious error which can be specified in greater detail by polling the event status register.</p>
6	<p>MSS bit (master status summary bit)</p> <p>The bit is set if the instrument triggers a service request. This is the case if one of the other bits of this registers is set together with its mask bit in the service request enable register SRE.</p>
7	<p>OPERation status register sum bit</p> <p>The bit is set if an EVENT bit is set in the OPERation status register and the associated ENABLE bit is set to 1. A set bit indicates that the instrument is just performing an action. The type of action can be determined by polling the OPERation status register.</p>

7.13.4 Event Status Register (ESR) and Event Status Enable Register (ESE)

The ESR is defined in IEEE 488.2. It can be compared with the EVENT part of a SCPI register. The event status register can be read out using command *ESR?.

The ESE is the associated ENABLE part. It can be set using the command *ESE and read using the command *ESE?.

Table 7-2: Meaning of the bits in the event status register

Bit No.	Meaning
0	Operation Complete This bit is set on receipt of the command *OPC exactly when all previous commands have been executed.
1	Not used
2	Query Error This bit is set if either the controller wants to read data from the instrument without having sent a query, or if it does not fetch requested data and sends new instructions to the instrument instead. The cause is often a query which is faulty and hence cannot be executed.
3	Device-dependent Error This bit is set if a device-dependent error occurs. An error message with a number between -300 and -399 or a positive error number, which denotes the error in greater detail, is entered into the error queue.
4	Execution Error This bit is set if a received command is syntactically correct but cannot be performed for other reasons. An error message with a number between -200 and -300, which denotes the error in greater detail, is entered into the error queue.
5	Command Error This bit is set if a command is received, which is undefined or syntactically incorrect. An error message with a number between -100 and -200, which denotes the error in greater detail, is entered into the error queue.
6	Not used
7	Power On (supply voltage on) This bit is set on switching on the instrument.

7.13.4.1 STATus:OPERation Register

In the CONDition part, this register contains information on which actions the instrument is being executing or, in the EVENT part, information on which actions the instrument has executed since the last reading. It can be read using the commands STATus:OPERation:CONDition? or STATus:OPERation[:EVENT]?

Table 7-3: Meaning of the bits in the STATus:OPERation register

Bit No.	Meaning
0	CALibrating This bit is set as long as the instrument is performing a calibration.
1 to 14	Not used
15	This bit is always 0

7.13.4.2 STATus:QUEStionable Register

This register contains information about indefinite states which may occur if the unit is operated without meeting the specifications. It can be read using the commands STATus:QUEStionable: CONDition? and STATus:QUEStionable[:EVENT]?

Table 7-4: Meaning of bits in STATus:QUEStionable register

Bit No.	Meaning
0 to 1	These bits are not used
2	BATTERY LOW If the instrument is running without any external power supply and the charging level of the internal battery is approximately lower than 5% this bit is set to indicate that the system will be shut down automatically in approx. 5 minutes.
3	Not used
4	TEMPerature This bit is set if a questionable temperature occurs.
5 to 8	Not used
9	LIMit (device-specific) This bit is set if a limit value is violated
10	CALibration The bit is set if a measurement is performed unaligned (label UNCAL)
11 to 14	Not used
15	This bit is always 0.

7.13.4.3 STATus:QUEStionable:FREQuency Register

This register contains information about the reference frequency. It can be read using the commands STATus:QUEStionable:LIMit:FREQuency? and STATus:QUEStionable:FREQuency[:EVENT]?

Table 7-5: Meaning of bits in STATus:QUEStionable:FREQuency register

Bit No.	Meaning
0 to 7	Not used
8	EXtErnal REfERENCE This bit is set if an external reference is used.
9 to 14	Not used
15	This bit is always 0.

7.13.4.4 STATus:QUEStionable:LIMit Register

This register contains information about the observance of limit lines. It can be read using the commands STATus:QUEStionable:LIMit:CONDition? and STATus:QUEStionable:LIMit[:EVENT]?

Table 7-6: Meaning of bits in STATus:QUEStionable:LIMit register

Bit No.	Meaning
0	LIMit 1 FAIL This bit is set if limit line 1 is violated.
1	LIMit 2 FAIL This bit is set if limit line 2 is violated.
2 to 14	Not used
15	This bit is always 0.

7.13.4.5 STATus:QUEStionable:POWer Register

This register contains information about possible overload states. It can be read using the commands STATus:QUEStionable:POWer:CONDition? and STATus:QUEStionable:POWer[:EVENT]?

Table 7-7: Meaning of bits in STATus:QUEStionable:POWer register

Bit No.	Meaning
0 to 1	Not used
2	IF_Overload This bit is set if the IF path is overloaded. 'IFOVL' is displayed.
3 to 14	Not used
15	This bit is always 0.

7.13.5 Application of the Status Reporting Systems

In order to be able to effectively use the status reporting system, the information contained there must be transmitted to the controller and further processed there. There are several methods which are represented in the following.

7.13.5.1 Service Request

Under certain circumstances, the instrument can send a service request (SRQ) to the controller. Usually this service request initiates an interrupt at the controller, to which the control program can react appropriately. As evident from Fig. 1-4, an SRQ is always initiated if one or several of bits 2, 3, 4, 5 or 7 of the status byte are set and enabled in the SRE. Each of these bits combines the information of a further register, the error queue or the output buffer. The ENABLE parts of the status registers can be set so that arbitrary bits in an arbitrary status register initiate an SRQ. In order to make use of the possibilities of the service request effectively, all bits should be set to "1" in enable registers SRE and ESE.

Example

Use of the command *OPC to generate an SRQ at the end of a sweep

```
CALL InstrWrite(analyzer, "*ESE 1")  
'Set bit 0 in the ESE (Operation Complete)  
  
CALL InstrWrite(analyzer, "*SRE 32")  
'Set bit 5 in the SRE (ESB)?
```

After its settings have been completed, the instrument generates an SRQ.

The SRQ is the only possibility for the instrument to become active on its own. Each controller program should set the instrument in a way that a service request is initiated in the case of malfunction. The program should react appropriately to the service request.

7.13.5.2 Serial Poll

In a serial poll, just as with command *STB, the status byte of an instrument is queried. However, the query is realized via interface messages and is thus clearly faster. The serial-poll method has already been defined in IEEE 488.1 and used to be the only standard possibility for different instruments to poll the status byte. The method also works with instruments which do not adhere to SCPI or IEEE 488.2.

The VISUAL BASIC command for executing a serial poll is IBRSP(). Serial poll is mainly used to obtain a fast overview of the state of several instruments connected to the controller.

7.13.5.3 Query by Means of Commands

Each part of any status register can be read by means of queries. The individual commands are listed in the description of the STATus Subsystem. The returned value is always a number that represents the bit pattern of the queried register. This number is evaluated by the controller program.

Queries are usually used after an SRQ in order to obtain more detailed information on the cause of the SRQ.

7.13.5.4 Error Queue Query

Each error state in the instrument leads to an entry in the error queue. The entries of the error queue are detailed plain-text error messages that can be displayed via manual operation using the setup menu or queried via remote control using the command SYSTem:ERRor?. Each call of SYSTem:ERRor? provides one entry from the error queue. If no error messages are stored there any more, the instrument responds with 0, "No error".

The error queue should be queried after every SRQ in the controller program as the entries describe the cause of an error more precisely than the status registers. Especially in the test phase of a controller program the error queue should be queried regularly since faulty commands from the controller to the instrument are recorded there as well.

7.13.6 Reset Values of the Status Reporting System

Table 7-8 contains the different commands and events causing the status reporting system to be reset. None of the commands, except *RST and SYSTem:PRESet, influences the functional instrument settings. In particular, DCL does not change the instrument settings.

Table 7-8: Resetting the status reporting system

Event	Switching on supply voltage		DCL,SDC			
	0	1				
	Power-On-Status-Clear		(Device Clear, Selected Device Clear)	*RST or SYSTem:PRESet	STATus:PRESet	*CLS
Effect	0	1				
Clear STB,ESR	—	yes	—	—	—	yes
Clear SRE,ESE	—	yes	—	—	—	—
Clear PPE	—	yes	—	—	—	—
Clear EVENT parts of the registers	—	yes	—	—	—	yes
Clear ENABLE parts of all OPERation and QUEStionable registers; Fill ENABLE parts of all other registers with "1".	—	yes	—	—	yes	—
Fill PTRansition parts with "1"; Clear NTRansition parts	—	yes	—	—	yes	—
Clear error queue	yes	yes	—	—	—	yes
Clear output buffer	yes	yes	yes	1)	1)	1)
Clear command processing and input buffer	yes	yes	yes	—	—	—

1) Every command being the first in a program message, i.e., immediately following a <PROGRAM MESSAGE TERMINATOR> clears the output buffer.

7.13.7 Remote Commands of the Status Reporting System

The following commands control the status-reporting system. *RST does not influence the status registers.

The OPERation status register contains information about the calibration status of the instrument.

The QUEStionable status register contains information about the status of the reference and local oscillator, possible overloads of the instrument and the status of limit checks and limit margins.

The commands are independent from the operating mode.

List of commands

- [STATus:PRESet](#) (p. 331)
- [STATus:QUEue\[:NEXT\]](#) (p. 332)
- [STATus:OPERation\[:EVENT\]?](#) (p. 332)
- [STATus:OPERation:CONDition?](#) (p. 332)
- [STATus:OPERation:ENABle <SumBit>](#) (p. 332)
- [STATus:OPERation:NTRansition <SumBit>](#) (p. 333)
- [STATus:OPERation:PTRansition <SumBit>](#) (p. 333)
- [STATus:QUEStionable\[:EVENT\]?](#) (p. 333)
- [STATus:QUEStionable:CONDition?](#) (p. 334)
- [STATus:QUEStionable:ENABle <SumBit>](#) (p. 334)
- [STATus:QUEStionable:NTRansition <SumBit>](#) (p. 334)
- [STATus:QUEStionable:PTRansition <SumBit>](#) (p. 335)

STATus:PRESet

This command resets the edge detectors and ENABle parts of all registers to a defined value. All PTRansition parts are set to FFFFh, i.e. all transitions from 0 to 1 are detected. All NTRansition parts are set to 0, i.e. a transition from 1 to 0 in a CONDition bit is not detected. The ENABle part of the STATus:OPERation and STATus:QUEStionable registers are set to 0, i.e. all events in these registers are not passed on.

Example

```
STAT:PRESet
```

Characteristics

*RST value: -
SCPI: conform

STATus:QUEue[:NEXT]

This command returns the earliest entry to the error queue and deletes it.

Positive error numbers indicate device-specific errors, negative error numbers are error messages defined by SCPI. If the error queue is empty, the error number 0, "no error", is returned. This command is identical with the command SYSTem:ERRor.

Example

```
STAT:QUE?
```

Characteristics

*RST value: –
SCPI: conform

STATus:OPERation[:EVENT]?

This command reads out the EVENT section of the OPERation register.

The command at the same time deletes the contents of the EVENT section.

Characteristics

*RST value: -
SCPI: conform

STATus:OPERation:CONDition?

This command reads out the CONDition section of the OPERation register.

The command does not delete the contents of the EVENT section.

Characteristics

*RST value: -
SCPI: conform

STATus:OPERation:ENABLE <SumBit>

This command controls the ENABLE part of the OPERation register.

The ENABLE part allows true conditions in the EVENT part of the status register to be reported in the summary bit. If a bit is 1 in the enable register and its associated event bit transitions to true, a positive transition will occur in the summary bit reported to the next higher level.

Parameter

<SumBit>
0 to 65535

Characteristics

*RST value: -
SCPI: conform

STATus:OPERation:NTRansition <SumBit>

This command controls the Negative TRansition part of the OPERation register.

Setting a bit causes a 1 to 0 transition in the corresponding bit of the associated register. The transition also writes a 1 into the associated bit of the corresponding EVENT register.

Parameter

<SumBit>
0 to 65535

Characteristics

*RST value: -
SCPI: conform

STATus:OPERation:PTRansition <SumBit>

This command controls the Positive TRansition part of the OPERation register.

Setting a bit causes a 0 to 1 transition in the corresponding bit of the associated register. The transition also writes a 1 into the associated bit of the corresponding EVENT register.

Parameter

<SumBit>
0 to 65535

Characteristics

*RST value: -
SCPI: conform

STATus:QUEStionable[:EVENT]?**STATus:QUEStionable:FREQuency[:EVENT]?****STATus:QUEStionable:LIMit[:EVENT]?****STATus:QUEStionable:POWEr[EVENT]?**

This command reads out the EVENT section of the QUEStionable register.

The command at the same time deletes the contents of the EVENT section.

Characteristics

*RST value: -
SCPI: conform

STATus:QUEStionable:CONDition?
STATus:QUEStionable:FREQuency:CONDition?
STATus:QUEStionable:LIMit:CONDition?
STATus:QUEStionable:POWer:CONDition?

This command reads out the CONDition section of the QUEStionable register.

The command does not delete the contents of the EVENt section.

Characteristics

*RST value: -

SCPI: conform

STATus:QUEStionable:ENABle <SumBit>
STATus:QUEStionable:FREQuency:ENABle <SumBit>
STATus:QUEStionable:LIMit:ENABle <SumBit>
STATus:QUEStionable:POWer:ENABle <SumBit>

This command controls the ENABle part of the QUEStionable register.

The ENABle part allows true conditions in the EVENt part of the status register to be reported in the summary bit. If a bit is 1 in the enable register and its associated event bit transitions to true, a positive transition will occur in the summary bit reported to the next higher level.

Parameter

<SumBit>

0 to 65535

Characteristics

*RST value: -

SCPI: conform

STATus:QUEStionable:NTRansition <SumBit>
STATus:QUEStionable:FREQuency:NTRansition <SumBit>
STATus:QUEStionable:LIMit:NTRansition <SumBit>
STATus:QUEStionable:POWer:NTRansition <SumBit>

This command controls the Negative TRansition part of the QUEStionable register.

Setting a bit causes a 1 to 0 transition in the corresponding bit of the associated register. The transition also writes a 1 into the associated bit of the corresponding EVENt register.

Parameter

<SumBit>

0 to 65535

Example

```
STAT:QUES:NTR 65535
```

Characteristics

*RST value: -
SCPI: conform

STATus:QUEStionable:PTRansition <SumBit>

STATus:QUEStionable:FREQuency:PTRansition <SumBit>

STATus:QUEStionable:LIMit:PTRansition <SumBit>

STATus:QUEStionable:POWer:PTRansition <SumBit>

This command control the Positive TRansition part of the QUEStionable register.

Setting a bit causes a 0 to 1 transition in the corresponding bit of the associated register. The transition also writes a 1 into the associated bit of the corresponding EVENT register.

Parameter

<SumBit>
0 to 65535

Characteristics

*RST value: -
SCPI: conform

Alphabetical List of Remote Commands

*CLS.....	33
*ESE	33
*ESR?	33
*IDN?	34
*IST?	34
*OPC.....	34
*OPT?	34
*RST	34
*SRE	35
*STB?.....	35
*TRG	35
*TST?.....	35
*WAI.....	35
ABORt.....	51
CALCulate:CALKit:USER:LENGth <ElecLength>	140
CALCulate:CALKit:USER:OFFSet<p>:LENGth <ElecLengthOffs>	140
CALCulate:CALKit:USER[:STATe].....	139
CALCulate:DTF:CABLe:LENGth <CableLength>.....	164
CALCulate:DTF:CABLe:PRESet <CableModel>	164
CALCulate:FEED <Result Display>.....	243
CALCulate:FEED <Result Display>.....	265
CALCulate:FEED <ResultDisplay>.....	186
CALCulate:FEED <ResultDisplay>.....	199
CALCulate:FEED <ResultDisplay>.....	215
CALCulate:FEED <ResultDisplay>.....	225
CALCulate:FEED <ResultDisplay>.....	231
CALCulate:LIMit<k>:ACPower:ACHannel:ABSolute <Limit>	106
CALCulate:LIMit<k>:ACPower:ACHannel:ABSolute:STATe <State>	106
CALCulate:LIMit<k>:ACPower:ACHannel:RESult?.....	107
CALCulate:LIMit<k>:ACPower:ACHannel[:RELative] <Limit>	105
CALCulate:LIMit<k>:ACPower:ACHannel[:RELative]:STATe <State>	105
CALCulate:LIMit<k>:ACPower:ALTErnate<y>:ABSolute <Limit>	108
CALCulate:LIMit<k>:ACPower:ALTErnate<y>:ABSolute:STATe <State>	108
CALCulate:LIMit<k>:ACPower:ALTErnate<y>:RESult?	109
CALCulate:LIMit<k>:ACPower:ALTErnate<y>[:RELative] <Limit>	107
CALCulate:LIMit<k>:ACPower:ALTErnate<y>[:RELative]:STATe <State>	108
CALCulate:LIMit<k>:ACPower[:STATe] <State>	105
CALCulate:MARKer:FUNCTion:ACPower:UNIT <Unit>	99
CALCulate:MARKer:FUNCTion:CDPower[:BTS]:RESult? <Result>.....	218
CALCulate:MARKer:FUNCTion:CDPower[:BTS]:RESult? <Result>.....	227
CALCulate:MARKer:FUNCTion:LEVel ONCE	183
CALCulate:MARKer:FUNCTion:PNSCan:LIST?	219
CALCulate:MARKer:FUNCTion:PNSCan:LIST?	227
CALCulate:MARKer:FUNCTion:POWER:SElect <Measurement>	91
CALCulate:MARKer:FUNCTion:POWER[:STATe] <State>	92
CALCulate:MARKer<m>:COUNT:FREQUency?	75
CALCulate:MARKer<m>:COUNT:RESolution:MODE <Resolution>.....	75

CALCulate:MARKer<m>:COUNT[:STATe] <State>	75
CALCulate:MARKer<m>:FREQUency:MODE <InputMode>	76
CALCulate:MARKer<m>:FUNCTion:CDPower[:BTS]:RESult? <Result>	236
CALCulate:MARKer<m>:FUNCTion:CENter	77
CALCulate:MARKer<m>:FUNCTion:DEModulation:HOLDoff <Time>	77
CALCulate:MARKer<m>:FUNCTion:DEModulation:SElect <Demodulation>	78
CALCulate:MARKer<m>:FUNCTion:DEModulation[:STATe] <State>	77
CALCulate:MARKer<m>:FUNCTion:NDBDown <Distance>	78
CALCulate:MARKer<m>:FUNCTion:NDBDown:FREQUency?	78
CALCulate:MARKer<m>:FUNCTion:NDBDown:RESult?	79
CALCulate:MARKer<m>:FUNCTion:NDBDown:STATe <State>	79
CALCulate:MARKer<m>:FUNCTion:NOISe:RESult?	80
CALCulate:MARKer<m>:FUNCTion:NOISe[:STATe] <State>	80
CALCulate:MARKer<m>:FUNCTion:REFerence	81
CALCulate:MARKer<m>:FUNCTion:TDMA:BURSt <BurstLength>	98
CALCulate:MARKer<m>:FUNCTion:WCDPower[:BTS]:RESult? <Result>	207
CALCulate:MATH<n>:COPY:MEMory	60
CALCulate:MATH<n>:STATe <State>	61
CALCulate:MATH<n>[:EXPReSSion][:DEFine] <Expression>	60
CALCulate:PMETer:CPOWER:BANDwidth <Bandwidth>	149
CALCulate:PMETer:PRESet:BANDwidth:VIDeo <Bandwidth>	153
CALCulate:PMETer:PRESet:SElect <Standard>	155
CALCulate:PMETer:PRESet[:STATe] <State>	154
CALCulate:PMETer:RELative[:MAGNitude] <RefValue>	149
CALCulate:PMETer:RELative[:MAGNitude]:AUTO ONCE	149
CALCulate:PMETer:RELative[:MAGNitude]:OFFSet <Offset>	150
CALCulate:TRACe:CABLE:LENGth:RESult?	143
CALCulate:TRACe:CABLE:LENGth[:STATe] <State>	142
CALCulate:TRACe:CABLE:LOSS:RESult?	165
CALCulate:TRACe:CABLE:TIME:RESult?	143
CALCulate:TRACe:CABLE:TIME[:STATe] <State>	143
CALCulate:TRACe:LIMit:VSWR:FAIL?	144
CALCulate:TRANSform:DTFault:PEAK:COUNT?	169
CALCulate:TRANSform:DTFault:PEAK:DATA<y>?	169
CALCulate:TRANSform:DTFault:PEAK:THReShold <Threshold>	170
CALCulate:TRANSform:DTFault:PEAK[:STATe] <State>	169
CALCulate:VVMeter:MAGNitude:REFerence?	145
CALCulate:VVMeter:MAGNitude:RESult?	146
CALCulate:VVMeter:PHASe:REFerence?	146
CALCulate:VVMeter:PHASe:RESult?	147
CALCulate:VVMeter:REFerence[:STATe] <State>	147
CALCulate<n>:DELTaMarker<m>:AOFF	67
CALCulate<n>:DELTaMarker<m>:MAXimum:NEXT	67
CALCulate<n>:DELTaMarker<m>:MAXimum[:PEAK]	67
CALCulate<n>:DELTaMarker<m>:MINimum[:PEAK]	68
CALCulate<n>:DELTaMarker<m>:X <Coordinate>	68
CALCulate<n>:DELTaMarker<m>:X:RELative <Distance>	69
CALCulate<n>:DELTaMarker<m>:Y?	69
CALCulate<n>:DELTaMarker<m>[:STATe] <State>	66
CALCulate<n>:DLINe <Amplitude>	82
CALCulate<n>:DLINe:STATe <State>	82
CALCulate<n>:LIMit<k>:BEEP[:STATe] <State>	83
CALCulate<n>:LIMit<k>:COMMeNt?	83
CALCulate<n>:LIMit<k>:DEFine	84
CALCulate<n>:LIMit<k>:DELeTe	85

CALCulate<n>:LIMit<k>:FAIL?	85
CALCulate<n>:LIMit<k>:LOWer:SElect <LimitLine>	85
CALCulate<n>:LIMit<k>:LOWer:THReshold <Level>	86
CALCulate<n>:LIMit<k>:STATe <State>	86
CALCulate<n>:LIMit<k>:UNIT:X?	86
CALCulate<n>:LIMit<k>:UNIT[:Y]?	87
CALCulate<n>:LIMit<k>:UPPer:SElect <LimitLine>	87
CALCulate<n>:LIMit<k>:UPPer:THReshold <Level>	87
CALCulate<n>:MARKer:FUNction:LEVel:ONCE	93
CALCulate<n>:MARKer:FUNction:POWer:PRESet <Standard>	92
CALCulate<n>:MARKer:FUNction:POWer:PRESet:CHEck?	92
CALCulate<n>:MARKer:FUNction:POWer:RESult? <Measurement>	93
CALCulate<n>:MARKer:FUNction:POWer:SEGmented:SElect <Measurement> ...	116
CALCulate<n>:MARKer:FUNction:POWer:SEGmented[:STATe] <State>	117
CALCulate<n>:MARKer<m>:AOFF	70
CALCulate<n>:MARKer<m>:FUNction:CPOWer:BANDwidth <Bandwidth>	95
CALCulate<n>:MARKer<m>:FUNction:CPOWer:MODE <DisplayMode>	95
CALCulate<n>:MARKer<m>:FUNction:CPOWer:UNIT <Unit>	96
CALCulate<n>:MARKer<m>:FUNction:HARMonics:DISToRtion? ToTAl	111
CALCulate<n>:MARKer<m>:FUNction:HARMonics:LIST?	111
CALCulate<n>:MARKer<m>:FUNction:HARMonics:NHARMonics <Harmonics>	112
CALCulate<n>:MARKer<m>:FUNction:HARMonics:PRESet	112
CALCulate<n>:MARKer<m>:FUNction:HARMonics[:STATe] <State>	110
CALCulate<n>:MARKer<m>:FUNction:MDEPth:RESult?	113
CALCulate<n>:MARKer<m>:FUNction:MDEPth[:STATe] <State>	113
CALCulate<n>:MARKer<m>:FUNction:OBAN:BANDwidth <Bandwidth>	97
CALCulate<n>:MARKer<m>:FUNction:OBAN:BANDwidth:PCT <OBW>	97
CALCulate<n>:MARKer<m>:FUNction:POWer:RESult:PHZ <State>	96
CALCulate<n>:MARKer<m>:FUNction:TXPower:RESult?	110
CALCulate<n>:MARKer<m>:FUNction:TXPower:RESult?	114
CALCulate<n>:MARKer<m>:MAXimum:NEXT	71
CALCulate<n>:MARKer<m>:MAXimum[:PEAK]	70
CALCulate<n>:MARKer<m>:MINimum[:PEAK]	71
CALCulate<n>:MARKer<m>:MODE <MarkerMode>	134
CALCulate<n>:MARKer<m>:X <Coordinate>	71
CALCulate<n>:MARKer<m>:X:SLIMits:LEFT <SearchLimit>	72
CALCulate<n>:MARKer<m>:X:SLIMits:RIGHT <Searchlimit>	73
CALCulate<n>:MARKer<m>:X:SLIMits[:STATe] <State>	72
CALCulate<n>:MARKer<m>:Y?	135
CALCulate<n>:MARKer<m>:Y?	73
CALCulate<n>:MARKer<m>[:STATe] <State>	70
CALibration:ABORt	166
CALibration:ATTenuation:STATus?	166
CALibration:CONTInue?	167
CALibration:MODE?	141
CALibration:PMETer:ZERO:AUTO ONCE	152
CALibration:START? <CalibrationMethod>	167
CALibration:STATus?	141
CONFigure:POWer:EXPEcted:RF <RefLevel>	242
CONFigure:POWer:EXPEcted:RF <RefLevel>	263
CONFigure[:LTE]:DEPLoyment <Deployment>	266
CONFigure[:LTE]:DL:BW<cc> <Bandwidth>	245

CONFigure[:LTE]:DL:BW<cc> <Bandwidth>	266
CONFigure[:LTE]:DL:CSUBframes <Subframes>	245
CONFigure[:LTE]:DL:CSUBframes <Subframes>	267
CONFigure[:LTE]:DL:CYCPrefix <Prefix>	246
CONFigure[:LTE]:DL:DEMod :MCFilter <State>	267
CONFigure[:LTE]:DL:MIMO:ASElection <Antenna>	246
CONFigure[:LTE]:DL:MIMO:ASElection <Antenna>	267
CONFigure[:LTE]:DL:MIMO<cc>:CONFig <Configuration>	246
CONFigure[:LTE]:DL:NCARriers <Carrier>	247
CONFigure[:LTE]:DL:NORB <ResourceBlocks>	247
CONFigure[:LTE]:DL:PINdex <Index>	270
CONFigure[:LTE]:DL:PLCI:CIDGroup <GroupID>	248
CONFigure[:LTE]:DL:PLCI:CIDGroup <GroupID>	268
CONFigure[:LTE]:DL:PLCI:CIDNtity <CellID>	247
CONFigure[:LTE]:DL:PLCI:CIDNtity <CellID>	268
CONFigure[:LTE]:DL:PLCI:PLID <Identity>	248
CONFigure[:LTE]:DL:PLCI:PLID <Identity>	269
CONFigure[:LTE]:DL:PSOFFset <Offset>	271
CONFigure[:LTE]:DL:SINFo <Sequence>	270
CONFigure[:LTE]:DL:TDD:UDConfig <Configuration>	249
DISPlay:BRIGHtness <Brightness>	303
DISPlay:CMAP <ColorScheme>	303
DISPlay:CMAP:DEFault	304
DISPlay:DATE:FORMat <DateFormat>	304
DISPlay:GDELay:APERture:STEP <Aperture>	144
DISPlay:WINDow:STORE	287
DISPlay[:WINDow]:TRACe:STYLe <Style>	178
DISPlay[:WINDow]:TRACe:Y[:SCALe]:RPOSITion <ReferencePosition>	44
DISPlay[:WINDow]:TRACe<n>:MEMory[:STATe] <State>	61
DISPlay[:WINDow]:TRACe<n>:MODE <TraceMode>	62
DISPlay[:WINDow]:TRACe<n>:Y:SPACing <Scaling>	42
DISPlay[:WINDow]:TRACe<n>:Y[:SCALe]:DISPlayRange>	43
DISPlay[:WINDow]:TRACe<n>:Y[:SCALe]:ADJust	42
DISPlay[:WINDow]:TRACe<n>:Y[:SCALe]:RLEVel <ReferenceLevel>	43
DISPlay[:WINDow]:TRACe<n>:Y[:SCALe]:RLEVel:OFFSet <Offset>	44
DISPlay[:WINDow]:TRACe<n>[:STATe] <State>	61
DISPlay<n>:GDELay:REFerence <RefValue>	120
DISPlay<n>:GDELay:REFerence:POSITion <RefPosition>	121
DISPlay<n>:GDELay:Y:SCALe <DisplayRange>	121
DISPlay<n>:IMPedance:REFerence:POSITion <Impedance>	136
DISPlay<n>:LOSS:REFerence <RefValue>	121
DISPlay<n>:LOSS:REFerence:POSITion <RefPosition>	122
DISPlay<n>:LOSS:Y:SCALe <DisplayRange>	122
DISPlay<n>:MAGNitude:REFerence <RefValue>	123
DISPlay<n>:MAGNitude:REFerence:POSITion <RefPosition>	123
DISPlay<n>:MAGNitude:Y:SCALe <DisplayRange>	123
DISPlay<n>:MAGNitude:Y:SPACing <Scaling>	124
DISPlay<n>:PHASe:REFerence <RefValue>	124
DISPlay<n>:PHASe:REFerence:POSITion <RefPosition>	124
DISPlay<n>:PHASe:UNWRap <State>	125
DISPlay<n>:PHASe:Y:SCALe <DisplayRange>	125
DISPlay<n>:REFlection:UNIT <Unit>	126
DISPlay<n>:REFlection:Y:SCALe <DisplayRange>	126
DISPlay<n>:VSWR:Y:SCALe <DisplayRange>	127

DISPlay<n>:VSWR:Y:SCALe:MAXimum <TopValue>.....	127
DISPlay<n>:VSWR:Y:SCALe:MINimum <BottomValue>.....	126
DISPlay<n>:ZOOM:AREA[:STAT] <State>	136
DISPlay<n>:ZOOM:FACTor <ZoomFactor>	137
DISPlay<n>:ZOOM:X <HorizShift>.....	137
DISPlay<n>:ZOOM:Y <VerticalShift>	137
FETCh:BURSt[:BTS]:BSIC?	189
FETCh:BURSt[:BTS]:MODulation?	189
FETCh:BURSt[:BTS]:OCCupiedbw?	190
FETCh:BURSt[:BTS]:PBURst?	190
FETCh:BURSt[:BTS]:PTOTal?	190
FETCh:BURSt[:BTS]:SLOTused?	191
FETCh:BURSt[:BTS]:TRAFfic?	191
FETCh:BURSt[:BTS]:TSC?	191
FETCh:BURSt[:MACCuracy]:ALL?	192
FETCh:BURSt[:MACCuracy]:BPOWer:CURRent?	192
FETCh:BURSt[:MACCuracy]:CTOI:RMS:CURRent?	192
FETCh:BURSt[:MACCuracy]:FREQuency:CURRent?	193
FETCh:BURSt[:MACCuracy]:IQOFfset:CURRent?	194
FETCh:BURSt[:MACCuracy]:MERRor:RMS:CURRent?	194
FETCh:BURSt[:MACCuracy]:PERRor:RMS:CURRent?	194
FETCh:BURSt[:MACCuracy][:EVM]:PEAK:CURRent?	193
FETCh:BURSt[:MACCuracy][:EVM]:SLOT:CURRent?	193
FETCh:CYCPrefix?	251
FETCh:PLCI:CIDGroup<cc>?	252
FETCh:PLCI:CIDGroup<cc>?	273
FETCh:PLCI:CIDNtity<cc>?	252
FETCh:PLCI:CIDNtity<cc>?	272
FETCh:PLCI:PLID<cc>?	252
FETCh:PLCI:PLID<cc>?	273
FETCh:SUMMary:EVM:<channel>?	255
FETCh:SUMMary:EVM:<channel>?	274
FETCh:SUMMary:EVM:<modulation>?	254
FETCh:SUMMary:EVM:DSQP?	274
FETCh:SUMMary:EVM:RSIGnal<cc>? <Antenna>	255
FETCh:SUMMary:EVM?	254
FETCh:SUMMary:EVM?	273
FETCh:SUMMary:FERRor<cc>?	253
FETCh:SUMMary:IQOFfset?	253
FETCh:SUMMary:OSTP?	256
FETCh:SUMMary:OSTP?	274
FETCh:SUMMary:POWer:<channel>?	256
FETCh:SUMMary:POWer:<channel>?	275
FETCh:SUMMary:POWer:<modulation>?	256
FETCh:SUMMary:POWer:DSQP?	275
FETCh:SUMMary:POWer:RSIGnal<cc>? <Antenna>	257
FETCh:SUMMary:POWer:SYNCsignal<cc>?	257
FETCh:SUMMary:POWer<cc>?	253
FETCh:SUMMary:POWer<cc>?	275
FETCh:SUMMary:RSRP?	258
FETCh:SUMMary:RSRQ?	258
FETCh:SUMMary:RSSI?	259
FETCh:SUMMary:RSSI?	276
FETCh:SUMMary:SINR?	258

FETCh:SUMMary:SINR?	276
FETCh:SUMMary:TAE<cc>? <Antenna>	259
FETCh:SUMMary:TRAFfic	260
FETCh:SUMMary:TRAFfic	277
FETCh<z>:PMETer?	153
FORMat:BORDer <ByteOrder>	62
FORMat[:DATA] <DataFormat>	65
HCOPy:DEVice:LANGuage	287
HCOPy[:IMMEDIATE]	288
INITiate:CONTInuous <SweepMode>	52
INITiate[:IMMEDIATE]	51
INPut:ANTenna:MEASure <Direction>	117
INPut:ANTenna:STATe <State>	118
INPut:IMPedance <Impedance>	46
INPut:IMPedance:PAD <MatchingPad>	310
INPut<n>:ATTenuation <Attenuation>	44
INPut<n>:ATTenuation:AUTO <State>	45
INPut<n>:ATTenuation:MODE <AttenuationMode>	45
INPut<n>:GAIN:STATe <State>	46
INSTrument:NSElect <OperatingMode>	295
INSTrument[:SElect] <OperatingMode>	294
MEASurement:MODE <MeasMode>	165
MEASurement:PORT <Port>	138
MEASurement<n>:FORMat <MeasFormat>	144
MEASurement<n>:FUNction:SElect <ResultDisplay>	142
MEASurement<n>:MODE <MeasMode>	139
MMEMory:CATalog:DIRectories?	280
MMEMory:CATalog?	279
MMEMory:CDIRectory <Directory>	280
MMEMory:COpy <SourceFile>,<DestinationFile>	280
MMEMory:DATA <FileName>[,<BlockData>]	281
MMEMory:DELEte <File>	282
MMEMory:FILE <File>	282
MMEMory:FILE:DATE <FileName>,<Date>	282
MMEMory:FILE:TIME <FileName>,<Time>	283
MMEMory:INIT	283
MMEMory:LOAD:STATe 1,<FileName>	284
MMEMory:MDIRectory <Directory>	284
MMEMory:MOVE <SourceFile>,<NewFileName>	284
MMEMory:NAME <FileName>	288
MMEMory:RDIRectory <Directory>	285
MMEMory:STORe:STATe 1,<FileName>	285
[SENSe:]BANDwidth[:RESolution]:CISPr <CISPRBandwidth>	175
[SENSe:]BANDwidth[:RESolution]:CISPr:AUTO <State>	175
[SENSe:]BANDwidth BWIDth<n>:VIDeo <VideoBW>	50
[SENSe:]BANDwidth BWIDth<n>:VIDeo:AUTO <State>	50
[SENSe:]BANDwidth BWIDth<n>[:RESolution] <ResBW>	49

[SENSe:]BANDwidth BWIDth<n>[:RESolution]:AUTO <State>	49
[SENSe:]BURSt:SLOT <Slot>	188
[SENSe:]BURSt:SLOT:AUTO <State>	188
[SENSe:]BURSt:TSC <Sequence>	187
[SENSe:]BURSt:TSC:AUTO <State>	187
[SENSe:]BWIDth:OCCupied:STATe <State>	244
[SENSe:]BWIDth:OCCupied?	195
[SENSe:]CDPower:ALENgtH <AnalysisLength>	200
[SENSe:]CDPower:ANTenna <Antenna>	201
[SENSe:]CDPower:CODE <Code>	201
[SENSe:]CDPower:CODE <Code>	216
[SENSe:]CDPower:CSEArch[:STATe] <State>	206
[SENSe:]CDPower:CSEArch[:STATe] <State>	235
[SENSe:]CDPower:FEMRange <Range>	201
[SENSe:]CDPower:LCODe:PRIMary <PrimScrambling>	204
[SENSe:]CDPower:LCODe:SEARch:AUTO <State>	204
[SENSe:]CDPower:LCODe:SEARch:LIST?	205
[SENSe:]CDPower:LCODe:SEARch[:IMMediate]	204
[SENSe:]CDPower:LCODe:SECOndary <SecSrambling>	205
[SENSe:]CDPower:MSHift <Shifts>	232
[SENSe:]CDPower:MSHift:AUTO <State>	233
[SENSe:]CDPower:ORDer <CodeOrder>	216
[SENSe:]CDPower:PHASes <PhaseType>	233
[SENSe:]CDPower:PNOFfset <PNOFfset>	217
[SENSe:]CDPower:PNOFfset <PNOFfset>	225
[SENSe:]CDPower:PNOFfset:AUTO <PNOFfset>	226
[SENSe:]CDPower:PNOFfset:AUTO	217
[SENSe:]CDPower:PREFEreNce <PowerMode>	202
[SENSe:]CDPower:PREFEreNce <Reference>	217
[SENSe:]CDPower:PREFEreNce <Reference>	226
[SENSe:]CDPower:PREFEreNce <Reference>	233
[SENSe:]CDPower:PSWitch <SwitchPoint>	234
[SENSe:]CDPower:SCODE <ScramblingCode>	234
[SENSe:]CDPower:SCODE:SEARch:AUTO <State>	235
[SENSe:]CDPower:SFACTOR <SpreadingFactor>	218
[SENSe:]CDPower:SLOT <Slot>	202
[SENSe:]CDPower:SLOT <Slot>	235
[SENSe:]CHANnel:TABLE:SELEct <ChannelTable>	89
[SENSe:]CHANnel<n> <ChannelNumber>	89
[SENSe:]CORRection:TRANSDucer<c>:ISOtropic[:STATe]?	118
[SENSe:]CORRection:TRANSDucer<c>:SELEct <TransducerFactor>	47
[SENSe:]CORRection:TRANSDucer<c>:UNIT?	47
[SENSe:]CORRection:TRANSDucer<c>[:STATe] <State>	46
[SENSe:]DETEctor<n>[:FUNctioN] <Detector>	178
[SENSe:]DETEctor<n>[:FUNctioN] <Detector>	63
[SENSe:]DETEctor<n>[:FUNctioN]:AUTO <State>	63
[SENSe:]ESPectrum:PRESet:SETTings ONCE	114
[SENSe:]ESPectrum:PRESet[:STANdard] <Standard>	114
[SENSe:]FREQUency:CARRier:STARt <Frequency>	115
[SENSe:]FREQUency:CARRier:STOP <Frequency>	116
[SENSe:]FREQUency:CENTer:STEP <StepSize>	37
[SENSe:]FREQUency:CENTer:STEP:LINK <StepSizeCoupling>	38
[SENSe:]FREQUency:CENTer<n> <Frequency>	37
[SENSe:]FREQUency:INPut:MODE<n> <InputMode>	38
[SENSe:]FREQUency:MODE <OperationMode>	172

[SENSe:]FREQUency:MODE <OperationMode>	39
[SENSe:]FREQUency:OFFSet <FrequencyOffset>	39
[SENSe:]FREQUency:SPAN<n> 	40
[SENSe:]FREQUency:SPAN<n>:AUTO <State>	40
[SENSe:]FREQUency:SPAN<n>:FULL	40
[SENSe:]FREQUency:STARt<n> <StartFrequency>	41
[SENSe:]FREQUency:STOP<n> <StopFrequency>	41
[SENSe:]PMETer:DETEctor[:FUNCTion] <PowerDisplay>	152
[SENSe:]PMETer:FREQUency <Frequency>	148
[SENSe:]PMETer:MTIME <MeasTime>	151
[SENSe:]POWER:ACHannel:ACPairs <ChannelPairs>	99
[SENSe:]POWER:ACHannel:BANDwidth:ACHannel <Bandwidth>	100
[SENSe:]POWER:ACHannel:BANDwidth:ALTErnate<y> <Bandwidth>	100
[SENSe:]POWER:ACHannel:BANDwidth[:CHANnel] <Bandwidth>	99
[SENSe:]POWER:ACHannel:MODE <PowerMode>	100
[SENSe:]POWER:ACHannel:PRESet:RLEVel	101
[SENSe:]POWER:ACHannel:REFerence:TXCHannel:AUTO <RefChannel>	101
[SENSe:]POWER:ACHannel:REFerence:TXCHannel:MANual <RefChannel>	102
[SENSe:]POWER:ACHannel:SPACing:ALTErnate<y> <Spacing>	103
[SENSe:]POWER:ACHannel:SPACing:CHANnel<Tx> <Spacing>	103
[SENSe:]POWER:ACHannel:SPACing[:ACHannel]] <Spacing>	102
[SENSe:]POWER:ACHannel:TXCHannel:COUNT <TxChannels>	103
[SENSe:]ROSCilator:SOURce <RefSource>	311
[SENSe:]SCAN:STARt <StartFrequency>	172
[SENSe:]SCAN:STEP <StepSize>	173
[SENSe:]SCAN:STOP <StopFrequency>	173
[SENSe:]SWEEp:COUNT<n> <SweepCount>	52
[SENSe:]SWEEp:EGATE <State>	56
[SENSe:]SWEEp:EGATE:HOLDoff <GateDelay>	56
[SENSe:]SWEEp:EGATE:LENGth <GateLength>	57
[SENSe:]SWEEp:EGATE:TIME <SweepTime>	57
[SENSe:]SWEEp:MODE <State>	115
[SENSe:]SWEEp:POINTS?	53
[SENSe:]SWEEp:TIME <MeasurementTime>	176
[SENSe:]SWEEp:TIME<n> <SweepTime>	53
[SENSe:]SWEEp:TIME<n>:AUTO <State>	53
[SENSe:]FREQUency:INPut:MODE<cc> <InputMode>	241
[SENSe:]CHANnel:TABLE:SELEct<cc> <ChannelTable>	240
[SENSe:]CHANnel<cc> <ChannelNumber>	240
[SENSe:]CHANnel<n>:TABLE:SELEct:DOWNlink <ChannelTable>	90
[SENSe:]CHANnel<n>:TABLE:SELEct:UPLink <ChannelTable>	90
[SENSe:]CHANnel<n>:TABLE:SET <Direction>	90
[SENSe:]FREQUency:CENTer<cc> <Frequency>	241
[SENSe][:LTE]:DL:DEMod:EVM:ASTD <State>	249
[SENSe][:LTE]:DL:DEMod:EVM:ASTD <State>	271
[SENSe][:LTE]:DL:DEMod:SYNCh <SyncSignal>	249
SOURce:TG:ATTenuation <Attenuation>	128
SOURce:TG:AUTO <State>	128
SOURce:TG:FREQUency <Frequency>	129
SOURce:TG:OFFSet <Level>	129
SOURce:TG:POWER <Level>	129
SOURce:TG[:STATe] <State>	130
STATus:OPERation:CONDition?	332

STATus:OPERation:ENABLE <SumBit>	332
STATus:OPERation:NTRansition <SumBit>	333
STATus:OPERation:PTRansition <SumBit>	333
STATus:OPERation[:EVENT]?	332
STATus:PRESet	331
STATus:QUEStionable:CONDition?	334
STATus:QUEStionable:ENABLE <SumBit>	334
STATus:QUEStionable:FREQuency:CONDition?	334
STATus:QUEStionable:FREQuency:ENABLE <SumBit>	334
STATus:QUEStionable:FREQuency:NTRansition <SumBit>	334
STATus:QUEStionable:FREQuency:PTRansition <SumBit>	335
STATus:QUEStionable:FREQuency[:EVENT]?	333
STATus:QUEStionable:LIMit:CONDition?	334
STATus:QUEStionable:LIMit:ENABLE <SumBit>	334
STATus:QUEStionable:LIMit:NTRansition <SumBit>	334
STATus:QUEStionable:LIMit:PTRansition <SumBit>	335
STATus:QUEStionable:LIMit[:EVENT]?	333
STATus:QUEStionable:NTRansition <SumBit>	334
STATus:QUEStionable:POWer:CONDition?	334
STATus:QUEStionable:POWer:ENABLE <SumBit>	334
STATus:QUEStionable:POWer:NTRansition <SumBit>	334
STATus:QUEStionable:POWer:PTRansition <SumBit>	335
STATus:QUEStionable:POWer[:EVENT]?	333
STATus:QUEStionable:PTRansition <SumBit>	335
STATus:QUEStionable[:EVENT]?	333
STATus:QUEue[:NEXT]	332
SYSTem:ACCessory:AUTO <State>	311
SYSTem:ACCessory?	311
SYSTem:AUDio:VOLume <Volume>	305
SYSTem:BEEPer:KEY:VOLume <Volume>	306
SYSTem:BEEPer:VOLume <Volume>	305
SYSTem:BNC<1...2>:MODE <BNCFunction>	312
SYSTem:CAPTure:COUNter <Counter>	289
SYSTem:CAPTure:DATaset[:STATe] <State>	289
SYSTem:CAPTure:GPX[:STATe] <State>	290
SYSTem:CAPTure:SCReen[:STATe] <State>	290
SYSTem:COMMunicate:LAN:ETHernet?	307
SYSTem:COMMunicate:LAN:GATeway <Gateway>	307
SYSTem:COMMunicate:LAN:SUBMask <SubnetMask>	308
SYSTem:COMMunicate:SOCKeT:ADDRess <IPAddress>	308
SYSTem:COMMunicate:SOCKeT:DHCP[:STATe] <State>	308
SYSTem:COMMunicate:SOCKeT:PORT <Port>	309
SYSTem:DATE <Date>	312
SYSTem:ERRor:ALL?	313
SYSTem:ERRor:CODE:ALL?	314
SYSTem:ERRor:CODE[:NEXT]?	314
SYSTem:ERRor:COUNT?	314
SYSTem:ERRor[:NEXT]?	313
SYSTem:FORMat:IDENt <IDNFormat>	315
SYSTem:FREQuency:REFerence:CONNected?	301
SYSTem:FREQuency:REFerence:CORRection:FREQuency?	302
SYSTem:FREQuency:REFerence:LOCKed?	301
SYSTem:HELP:HEADers?	315
SYSTem:HELP:SYNTax?	316

SYSTem:LANGUage <Language>	316
SYSTem:LANGUage:CATalog?.....	316
SYSTem:POSition:ALTitude?	296
SYSTem:POSition:COMPass:ANGLE?	296
SYSTem:POSition:COMPass:VALid?	297
SYSTem:POSition:COMPass[:STATe] <State>	297
SYSTem:POSition:GPS:CONNected?	298
SYSTem:POSition:GPS:CORRection:FREQUency?.....	298
SYSTem:POSition:GPS:QUALity?	298
SYSTem:POSition:GPS:SATellites?	299
SYSTem:POSition:GPS[:STATe] <State>.....	297
SYSTem:POSition:LATitude?	299
SYSTem:POSition:LONGitude?	300
SYSTem:POSition:VALid?.....	300
SYSTem:POWer:SOURce?	317
SYSTem:POWer:STATus?.....	317
SYSTem:PRESet.....	317
SYSTem:PRESet:FACTory	318
SYSTem:PRESet:MODE <Mode>.....	318
SYSTem:PRESet:USER <Preset>	318
SYSTem:REBoot	319
SYSTem:SET:LOCK <FileName>	286
SYSTem:SET:UNLock <FileName>	286
SYSTem:SHUTdown	319
SYSTem:SOEVent[:STATe] <State>.....	293
SYSTem:SOEVent:DISTance:INTerval <Distance>	291
SYSTem:SOEVent:LIMits:MODE <Mode>.....	291
SYSTem:SOEVent:RECORDing:STORage <Device>	292
SYSTem:SOEVent:SOURce <EventType>.....	292
SYSTem:SOEVent:TIME:INTerval <Time>	293
SYSTem:TIME <Time>.....	319
SYSTem:TZONee <TimeShift>	320
SYSTem:VERSion?	320
TRACe:DATA <Destination>	160
TRACe:DATA <Trace>	238
TRACe:DATA? <Trace>	262
TRACe:DATA? <Trace>	278
TRACe:DATA?.....	179
TRACe:DATA?.....	228
TRACe:IQ:DATA:MEMory? [<OffsetSamples>,<Samples>].....	54
TRACe:IQ:RLENgth <Samples>	55
TRACe:IQ:SRATe <SampleRate>.....	55
TRACe:IQ[:STATe] <State>	55
TRACe[:DATA] <Trace>	195
TRACe[:DATA] <Trace>	208
TRACe[:DATA]?.....	132
TRACe[:DATA]?.....	219
TRACe<n>:DATA:MEMory? <Trace>	64
TRACe<n>[:DATA]? <Destination>.....	63
TRIGger[:SEQUence]:CLOCK[:FREQUency] <ClockRate>	57
TRIGger[:SEQUence]:SOURce <TriggerSource>	177
TRIGger[:SEQUence]:SOURce <TriggerSource>	214
TRIGger[:SEQUence]:SOURce <TriggerSource>	222

TRIGger[:SEQuence]:SOURce <TriggerSource>	243
TRIGger[:SEQuence]:SOURce <TriggerSource>	264
TRIGger<n>[:SEQuence]:HOLDoff[:TIME] <TriggerDelay>	58
TRIGger<n>[:SEQuence]:LEVel:VIDeo <TriggerLevel>	58
TRIGger<n>[:SEQuence]:SLOPe <TriggerSlope>	58
TRIGger<n>[:SEQuence]:SOURce <TriggerSource>	59
UNIT:CFE <Unit>	250
UNIT:CFE <Unit>	271
UNIT:EVM <Unit>	209
UNIT:EVM <Unit>	236
UNIT:EVM <Unit>	250
UNIT:EVM <Unit>	272
UNIT:FERRor <Unit>	196
UNIT:FERRor <Unit>	210
UNIT:FERRor >Unit>	236
UNIT:LENGth <Unit>	161
UNIT<n>:POWer <Unit>	48
UNIT<z>:PMETer:POWer <Unit>	150

Index

1xEV-DO	221	TD-SCDMA	231
Abort measurement	51	WCDMA	199
ACLR	98	Channel table selection	89, 240
limit check	104, 109	Code	
Adjacent channel spacing	102	WCDMA	201
Adjacent channels	99	Code order	216
Alternate channel spacing	103	Color scheme	303
Alternate channels	100	Common commands	33
AM modulation depth	112	Continuous sweep	52
Antenna		Cyclic prefix	246
LTE	246	Data capture	289, 291
NB-IoT	267	Data format	65
Antenna diversity	201	Data management	279
Aperture step	144	Date	312
Attenuation	44	Delay time	143
Attenuation coupling	45	Delta marker	66
Attenuation mode	45	deactivation	67
Audio demodulation	77	horizontal position	68
Bandwidth		vertical position	69
1xEV-DO	222	Detector	63, 178
ACLR	99	Digital modulation	182
adjacent channels	100	Display	303
alternate channels	100	Display line	82
CDMA2000	213	Display range	42, 124
channel power	95	cable loss	122
LTE	245	group delay	43, 121
occupied bandwidth	97	magnitude	123
resolution	49	phase	125
TD-SCDMA	230	reflection coefficient	126
video	50	VSWR	127
WCDMA	184, 198	Distance	157
Battery	317	DTF list	169
Beeper	305	DTF threshold	170
BNC	312	Electrical length	140, 142
Brightness	303	Error queue	313
Burst length	98	EVM	
Cable distance	157	LTE	251
Cable length	164	NB-IoT	272
Cable selection	164	File	279
Calibration	139	Frequency	
user	139	1xEV-DO	221
CDMA2000	212	cable tests	157
Cell identity	247, 268	CDMA2000	212
Center frequency	37	GSM	183
Channel power		LTE	240
trace mode	95	NB-IoT	263
unit	96	power meter	148
Channel power measurement	95	span auto	40
Channel search		TD-SCDMA	229
WCDMA	206	WCDMA	197
Channel selection	89, 240	Frequency counter	75
Channel spacing	102	Frequency domain	39
Channel table		Frequency mode	38, 241
1xWV-DO	224	Frequency mode (marker)	76
CDMA2000	214	Frequency offset	39
GSM	185	Frequency span	40

Frequency step size.....	37	Operating mode.....	294
Frequency step size coupling.....	38	Option	
Full span.....	40	K10.....	183
Gate delay.....	56	K41.....	156
Gate length.....	57	K42.....	119
Gated trigger.....	56	K43.....	171
Gateway.....	307	K44.....	197
GPS.....	296	K45.....	119
GSM.....	183	K46.....	212
Hardcopy.....	287	K47.....	221
Harmonic distortion.....	110	K48.....	229
I/Q capture.....	54	K50.....	240
Impedance.....	46, 136, 310	K51.....	240
Input attenuation.....	44	K56.....	263
Isotropic antenna.....	117, 177	Phase unwrap.....	125
LTE.....	251	PN offset	
WCDMA.....	206	1xEV-DO.....	225
LAN.....	307	CDMA2000.....	217
Language.....	316	Port.....	138
Length unit.....	161	Position.....	296
Level axis.....	158	Power (system).....	317
Limit check		Power percentage.....	97
ACLR.....	104, 109	Power reference	
Limit lines.....	83, 163, 181	1xEV-DO.....	226
LTE.....	240	CDMA2000.....	217
Marker.....	70	TD-SCDMA.....	233
deactivation.....	70	WCDMA.....	202
horizontal position.....	71	Preamplifier.....	46
search limits.....	72	Preset.....	34, 317
vertical position.....	73	Reference impedance.....	136
zoom.....	136	Reference level.....	43
Marker mode.....	134	adjustment.....	93, 101
Measurement		power meter.....	150
abort.....	51	Reference level offset.....	44
ACLR.....	98	Reference position.....	44
AM modulation depth.....	112	cable loss.....	122
channel power.....	95	group delay.....	121
DTF.....	156	magnitude.....	123
EMI.....	171	phase.....	124
harmonic distortion.....	110	Reference power	
network analysis.....	139	WCDMA.....	202
noise.....	80	Reference signal.....	257
occupied bandwidth.....	96	Reference value	
selection.....	91	cable loss.....	121
spectrum emission mask.....	113	group delay.....	120
spurious emission.....	115	magnitude.....	123
start.....	51	phase.....	124
TDMA.....	97	power meter.....	149
Measurement control.....	159	Resolution bandwidth.....	49
Measurement format.....	142	Resource block.....	247
Measurement results.....	93	Restoring.....	279
Measurement time		Result display.....	141
power sensor.....	151	1xEV-DO.....	225
MIMO configuration.....	246	CDMA2000.....	215
Mode.....	294	GSM.....	185
n dB down.....	79	LTE.....	243
NB-IoT.....	263	NB-IoT.....	265
Network.....	307	TD-SCDMA.....	231
Noise measurement.....	80	WCDMA.....	199
Occupied bandwidth.....	96	Results.....	63, 93, 132, 160, 179

1xEV-DO	226	Sweep time	53, 57
CDMA2000	218	TDMA burst length	98
delay time	143	TDMA measurement	97
electrical length	143	TD-SCDMA	229
GSM	188	Time	319
LTE	251	Time domain	39
NB-IoT	272	Trace math	60
power meter	153	Trace memory	61
TD-SCDMA	236	Trace read out	63, 132, 160, 179
VSWR	144	Trace selection	61
WCDMA	206	Tracking generator	128
Saving	279	Traffic activity	
Scale adjust	42	LTE	260
Scan	172	NB-IoT	277
Scrambling code	202	Transducer	46
Screenshot	287	Transducer (isotropic antenna)	118
Segmented sweep	116	Transducer factor unit	47
Single sweep	52	Transducer selection	47
Slot		Transmission channels	103
WCDMA	202	Trigger	59, 177
Smith chart		gate	56
zoom	136	Trigger delay	58
Span	40	Trigger slope	58
Spectrum emission mask	113	Trigger source	59, 177
Spreading factor		Unit	48
CDMA2000	218	GSM	196
Spurious emissions	115	LTE	250
Standard compliance check	92	power sensor	150
Standard selection	92, 114	WCDMA	209
Start frequency	41	User calibration	139
Start measurement	51	vector voltmeter	145
Stop frequency	41	Video bandwidth	50
Subframe	245, 267	Video trigger level	58
Sweep count	52	Volume	305
Sweep mode	52	WCDMA	197
Sweep points	53	Zeroing	152