

R&S®THU9/R&S®THV9

Liquid-cooled transmitter families

Efficiency redefined



R&S®THU9/ R&S®THV9 Liquid-cooled transmitter families At a glance



The R&S®THU9/R&S®THV9 UHF/VHF high-power transmitter families make terrestrial broadcasting of TV and digital audio broadcast signals extremely efficient. They feature high energy efficiency of up to 42 % for UHF and up to 50 % for VHF, outstanding configuration flexibility and exceptional operating convenience in a very small footprint. For network operators, this means cost reductions over the entire system lifetime.

In the UHF band, the liquid-cooled transmitters deliver output power of up to 75 kW for digital standards in Doherty operation, and up to 58 kW for analog standards. In the VHF band, the maximum output power for digital TV and digital audio broadcasting is 30 kW, and 58 kW for analog standards. Rohde & Schwarz also offers the highest power density on the market with as much as 15 kW per rack for COFDM standards.

In Doherty mode, the R&S®THU9/R&S®THV9 transmitter families attain efficiency values of up to 42 % for UHF and up to 50 % for VHF, including the cooling system – for maximum energy and CO₂ savings. In Doherty operation, users can save up to 50% of energy costs compared with conventional transmitters.

The transmitters offer unparalleled flexibility and scalability in an extremely compact design. The family portfolios range from single transmitters with built-in pump unit and bandpass filter to multitransmitter systems and even N+1 configurations in a single rack. The new operating concept is based on an ergonomic operating unit, straightforward, easy-to-use menus and a convenient configuration guide.

Key facts

- Superior efficiency on the market thanks to innovative transmitter design and the use of Doherty technology
- Scalable and flexible system configuration
- Unique MultiTX system with multiple transmitters in a single rack
- Highest power density per transmitter rack
- User-friendly operating terminal and GUI
- Optimized total cost of ownership (TCO)

Outstanding efficiency		UHF	VHF
COFDM	Doherty mode	38%	46%
	Normal mode	28%	33%
ATSC	Doherty mode	42%	50%
	Normal mode	30%	43%

COFDM: DVB-T, DVB-T2, ISDB-T_(B), DTMB, DAB, DAB+, T-DMB

R&S®THU9/ R&S®THV9 Liquid-cooled transmitter families

Benefits and key features

Brilliant efficiency

- ▮ Superior efficiency due to unique system design
- ▮ Innovative amplifier with high efficiency
- ▮ Voltage regulation and crest factor reduction
- ▮ Efficient liquid cooling system

▷ [page 5](#)

Scalable and flexible system configuration

- ▮ MultiTX system with multiple transmitters and configurations in a single rack
- ▮ R&S®TCE900 – a multitalent as transmitter control unit or exciter
- ▮ Simple switchover from analog to digital TV
- ▮ IP transport stream feed to reduce infrastructure costs
- ▮ Integrated satellite receiver for fewer components in the rack

▷ [page 8](#)

Multifaceted, compact design

- ▮ Highest power density on the market
- ▮ MultiTX system with up to four transmitters per rack
- ▮ All-in-one transmitter with built-in pump unit and bandpass filter
- ▮ Space-saving, flexible liquid cooling system

▷ [page 10](#)

Simple operation for fast results

- ▮ Ergonomic, user-friendly operating unit
- ▮ Simplified navigation with device-oriented views
- ▮ Task-oriented menus for fast training of operating personnel

▷ [page 11](#)

E⁵ – efficiency to the power of five

The R&S®Tx9 transmitter generation scores with efficiency on five different levels:

▮ Efficiency in energy

Economical: minimum power consumption for cost savings over system lifetime

▮ Efficiency in space

Space-saving: several transmitters and additional components in one rack

▮ Efficiency in operation

Smooth: installation, operation and maintenance

▮ Efficiency in configuration

Customer-focused: modular solutions for flexible system configuration

▮ Efficiency for a lifetime

Future-ready: can be expanded to accommodate new standards and technologies



Model overview

R&S®THU9/R&S®THV9 transmitter system										
Number of amplifiers	1	2	3	4	5	6	8	10	12	
UHF										
Output power (AVG) ¹⁾										
for COFDM										
Normal mode	1.3 kW	2.6 kW	3.9 kW	5.2 kW	6.4 kW	7.7 kW	10.0 kW	12.5 kW	15.0 kW	
Doherty mode	1.15 kW	2.3 kW	3.5 kW	4.65 kW	5.8 kW	7.0 kW	9.2 kW	11.3 kW	13.5 kW	
for ATSC/ATSC Mobile DTV										
Normal mode	1.6 kW	3.2 kW	4.8 kW	6.4 kW	8.0 kW	9.5 kW	12.5 kW	15.0 kW	18.5 kW	
Doherty mode	1.15 kW	2.3 kW	3.5 kW	4.65 kW	5.8 kW	7.0 kW	9.2 kW	11.3 kW	13.5 kW	
Output power (sync peak) ²⁾										
for ATV	2.5 kW	5.0 kW	7.5 kW	10.0 kW	12.5 kW	15.0 kW	20.0 kW	24.5 kW	30.0 kW	
VHF										
Output power (AVG) ¹⁾										
for COFDM										
Normal/Doherty mode	1.3 kW	2.6 kW	3.9 kW	5.2 kW	6.5 kW	7.7 kW	10.0 kW	12.5 kW	15.0 kW	
for ATSC/ATSC Mobile DTV										
Normal mode	1.6 kW	3.3 kW	4.9 kW	6.5 kW	8.2 kW	9.7 kW	13.0 kW	16.0 kW	19.0 kW	
Doherty mode	1.3 kW	2.6 kW	3.9 kW	5.2 kW	6.5 kW	7.7 kW	10.0 kW	12.5 kW	15.0 kW	
Output power (sync peak) ^{2), 3)}										
for ATV	2.5 kW	5.0 kW	7.5 kW	10.0 kW	12.0 kW	14.0 kW	19.0 kW	24.0 kW	29.0 kW	
Dimensions (H x W x D)	2000 mm x 600 mm x 1100 mm (78.74 in x 23.62 in x 43.31 in)									
Number of transmitters per rack with MultiTX	up to 4			up to 3		up to 2		1		

R&S®THU9/R&S®THV9 transmitter system										
Number of amplifiers	16	20	24	30	36	40	48	60	72	
UHF										
Output power (AVG) ¹⁾										
for COFDM										
Normal mode	20.0 kW	24.0 kW	29.0 kW							
Doherty mode	18.0 kW	22.0 kW	26.5 kW	32.0 kW	39.0 kW	43.0 kW	50.0 kW	60.0 kW	75.0 kW	
for ATSC/ATSC Mobile DTV										
Normal mode	24.5 kW	30.0 kW	36.0 kW							
Doherty mode	18.0 kW	22.0 kW	26.5 kW	32.0 kW	39.0 kW	43.0 kW	50.0 kW	60.0 kW	75.0 kW	
Output power (sync peak) ²⁾										
for ATV	39.0 kW	48.0 kW	58.0 kW							
VHF										
Output power (AVG) ¹⁾										
for COFDM										
Normal/Doherty mode	20.0 kW	25.0 kW	30.0 kW							
for ATSC/ATSC Mobile DTV										
Normal mode	25.0 kW	31.0 kW	38.0 kW							
Doherty mode	20.0 kW	25.0 kW	30.0 kW							
Output power (sync peak) ^{2), 3)}										
for ATV	39.0 kW	48.0 kW	58.0 kW							
Dimensions (H x W x D)	2000 mm x 1200 mm x 1100 mm (78.74 in x 47.24 in x 43.31 in)			2000 mm x 1800 mm x 1100 mm (78.74 in x 70.87 in x 43.31 in)		2000 mm x 2400 mm x 1100 mm (78.74 in x 94.49 in x 43.31 in)		2000 mm x 3600 mm x 1100 mm (78.74 in x 141.74 in x 43.31 in)		

¹⁾ Before bandpass filter.

²⁾ After four-cavity bandpass filter.

³⁾ Specifications only valid for dual sound. The output power for single sound is slightly less.

Brilliant efficiency

Superior efficiency due to unique system design

The transmitter families lead the market for solid-state TV transmitters, attaining efficiency values of up to 42% in the UHF range and up to 50% in the VHF range, including the cooling system. This level of performance is the result of constant innovation at Rohde&Schwarz, based on many years of experience in the development of solid-state, liquid-cooled transmitters and pioneering implementation of Doherty technology.

The R&S®THU9/R&S®THV9 transmitter families have been designed with high efficiency in mind. The power combiner, harmonics filter and RF rigid line feature minimum attenuation. Together with the other components, they decisively contribute to the high efficiency of the entire transmitter system.

Transmitter system with Doherty amplifier

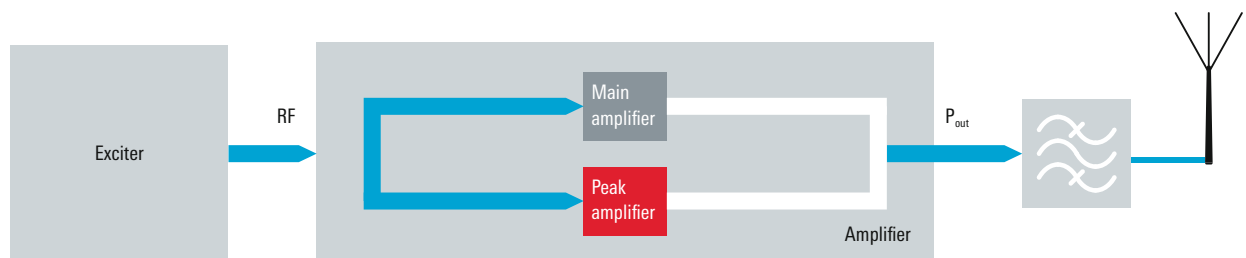

Liquid-cooled R&S®PHU902 Doherty amplifier.



Innovative amplifier with high efficiency

Thanks to the new Doherty amplifier technology, the R&S®THU9/R&S®THV9 transmitters reach new highs in efficiency. With 42% for UHF and up to 50% for VHF, the transmitters set new standards in their class. Other transmitters on the market have an average efficiency of approx. 20%. Compared with this figure, energy costs can be reduced by almost half using the R&S®THU9/R&S®THV9.

Even in normal mode, the R&S®THU9/R&S®THV9 transmitters provide outstanding energy efficiency of up to 30% for UHF and up to 33% for VHF including the cooling system. In normal mode, each UHF amplifier delivers an output power of 1.35 kW for COFDM standards (1.7 kW for ATSC and 2.8 kW for ATV). UHF amplifiers in Doherty mode provide an output power of 1.2 kW for DTV. VHF amplifiers reach an output power of 1.35 kW for digital standards both in Doherty and normal mode. For ATV, VHF amplifiers provide an output power of 2.7 kW in normal mode.

In the Doherty concept, signal amplification is divided into two paths. The main amplifier amplifies only the average signal. This has the advantage that no power reserves for peak signals are required in this path. The peak amplifier only needs to be put into operation in the event of signal power peaks, helping to save energy costs. The implementation of the intelligent multiband Doherty technology from Rohde&Schwarz allows an amplifier to be used over the entire frequency band with few modifications.

The power transistors use sophisticated 50 V LDMOS technology. The close cooperation between Rohde&Schwarz and the semiconductor manufacturer and the optimal matching of the transistors result in excellent efficiency and long-term stability of the amplifier board.

The optimized design of the aluminum heat sink in the amplifier ensures that all transistors operate at the same temperature and eliminates the need for separate fans.

Three efficient, integrated power supplies deliver power for the transistors. Thanks to the integrated power supply redundancy, Doherty amplifiers remain in operation at full output power even if one of the power supplies fails.

Voltage regulation and crest factor reduction

In addition to optimizing system design, Rohde&Schwarz included two other innovative approaches in its technology mix to significantly improve efficiency. The resulting power efficiency exceeds the performance of conventional solid-state technologies.

The unique voltage regulation circuit offered by Rohde&Schwarz yields a major increase in efficiency. The regulation mechanism in the transmitter control unit allows transmitter efficiency to be optimized for all digital standards. The signal decoupled by the directional coupler at the transmitter output is routed back to the R&S®TCE900 exciter and analyzed. At the same time, the power supplies in the amplifiers iteratively adjust the supply voltage for the power transistors. This voltage regulation circuit significantly improves efficiency, especially when a transmitter is operated at reduced output power.

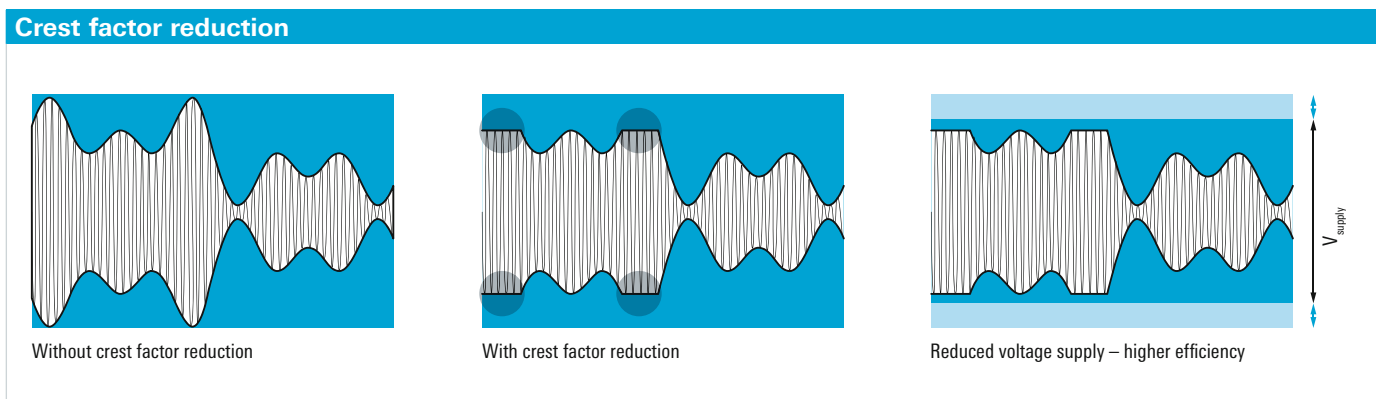

With the R&S®TCE900 exciter, Rohde&Schwarz is the first manufacturer to offer a reduction of the crest factor for all COFDM standards. The crest factor is reduced to 8 dB without any negative impact on MER, effectively improving the total transmitter efficiency. For DVB-T2, the tone reservation method defined in the standard can alternatively be used to reduce the crest factor.

The heat exchangers are equipped with two ultramodern fans that have extremely low-noise blades and are highly efficient due to the use of electronically commutated (EC) technology in the motors. The R&S®TCE900 transmitter control unit adjusts the fan speed according to the temperature measured at the input of the transmitter rack, saving still more energy.

Efficient liquid cooling system

The cooling system is another key factor for the efficiency of the entire system, which is why it has been optimized throughout.

The cooling system of the R&S®THU9/R&S®THV9 is equipped with efficient field-proven components. The pump rack contains two pump modules that operate in active standby to ensure high system availability. The necessary coolant flow is calculated based on the system configuration and the number of amplifiers. The rotational speed of the pumps is adapted to the coolant flow to save energy and extend transmitter life.

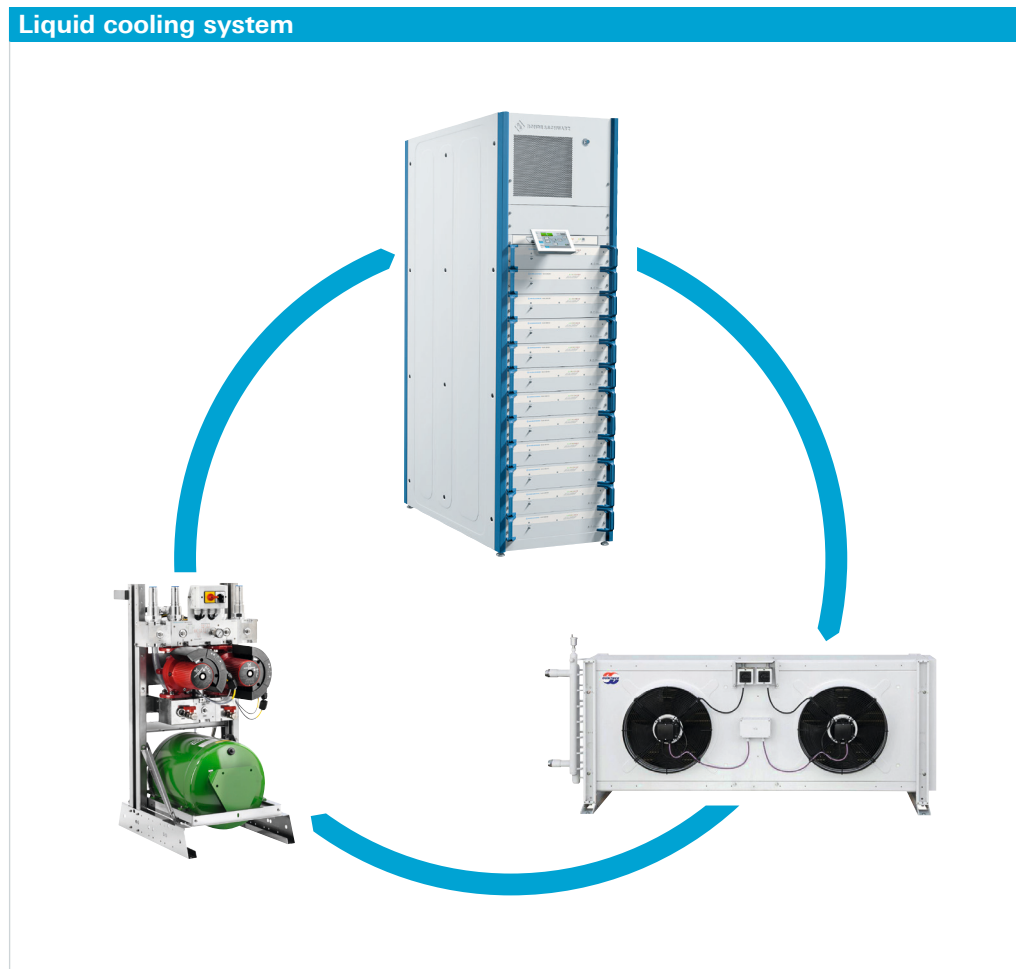

Scalable and flexible system configuration

MultiTX system with multiple transmitters and configurations in a single rack

Up to now, multitransmitter systems in a single rack have only been available for air-cooled transmitters. Rohde&Schwarz has now implemented this MultiTX system concept for the R&S®THU9/R&S®THV9 transmitter families of liquid-cooled high-power transmitters.

This approach saves the operator real money because up to four transmitters can be installed in one rack. An R&S®TCE900 system control unit monitors the transmitters and establishes a connection to the monitoring room via web interface or SNMP. It also controls the central cooling system with pump unit and heat exchanger. Depending on requirements, the transmitters can be configured with a single drive or a dual drive.

N+1 configurations can also be implemented in a single rack. Multitransmitter systems are available for all offered transmission standards and with different output power ratings in transmitter configurations with up to six amplifiers.

MultiTX opens up totally new dimensions in flexibility and scalability at moderate cost. If the transmitter site is to be expanded later, the rack can be ordered with the necessary additional RF components such as splitters

Example of a MultiTX system with three 5.2 kW DVB-T transmitters in a single rack

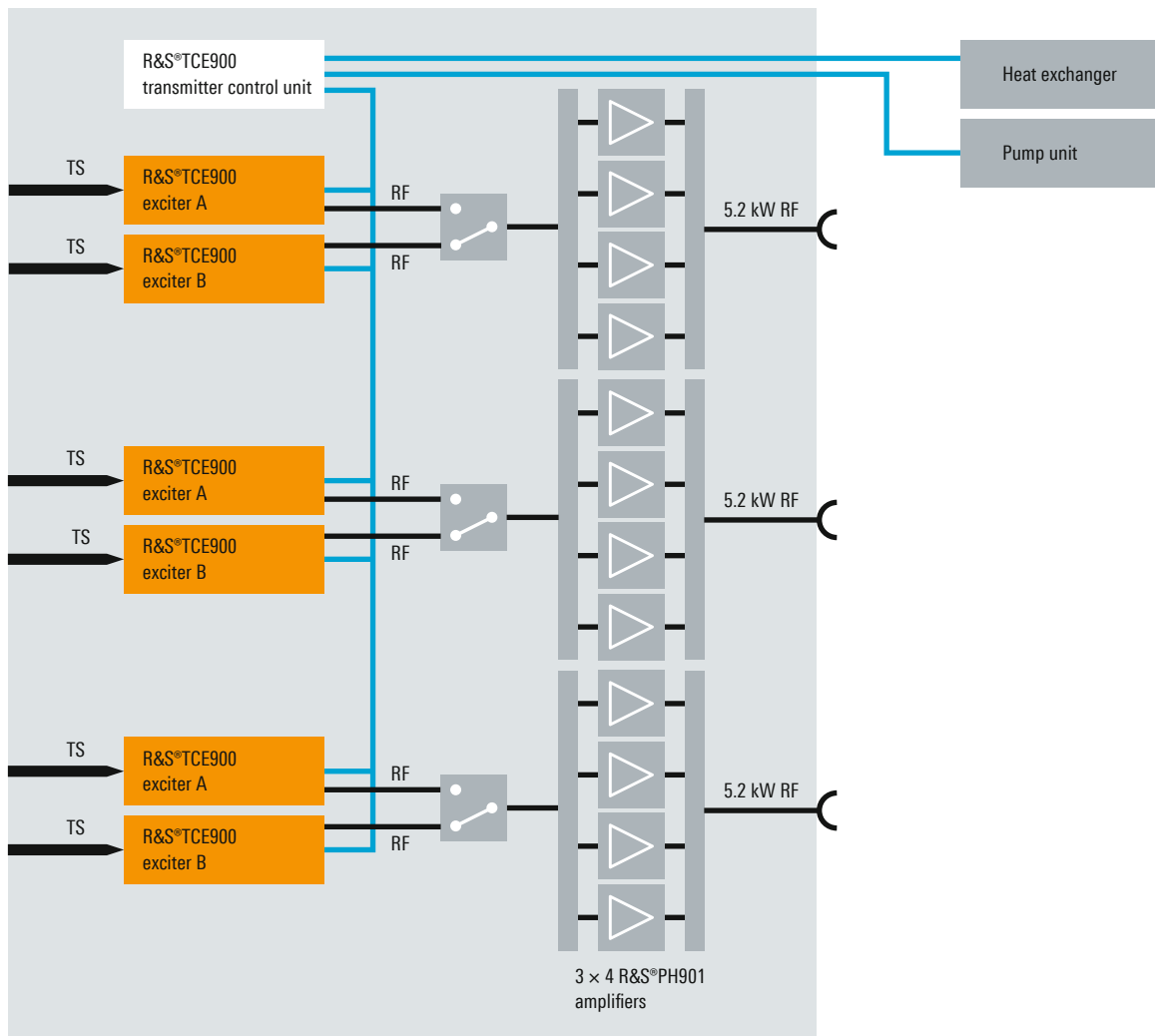

and combiners. All that is then needed to put the transmitter multiplex into operation is to simply install the additional exciters and amplifiers. System expansion poses no problem at all because the amplifiers feature practice-proven self-engaging connectors, and the exciters and system components on the top of the rack are easy to access.

Thanks to the new design, this high-power multitransmitter system meets the high availability requirements. Separate AC supply inlets provide power autonomy for each single transmitter.

The robust cooling system is able to handle environmental influences such as overvoltage. Separate data and AC supply lines for each pump module and each fan on the heat exchanger as well as multistage lightning and overvoltage protection circuits provide optimal protection for the system.

R&S®TCE900 – a multitalent as transmitter control unit or exciter

The R&S®THU9/R&S®THV9 transmitter families are based on the new R&S®TCE900 platform. By inserting specific plug-in boards, the base unit can be configured as a transmitter control unit or as an exciter. This results in greater flexibility for network operators. To reconfigure the R&S®TCE900 on site for another application, the user simply needs to exchange the modules. The platform also offers free option slots for expanding its functionality (e.g. by adding satellite receivers). Thanks to the system's modularity, both DAB and TV network operators can look forward to cost savings since they will require fewer spare parts.

When configured as a transmitter or system control unit, the R&S®TCE900 ensures smooth operation of the transmitter system. The R&S®TCE900 connects to the different system components via two plug-in boards: The cooling interface connects the pump unit, the heat exchanger and various sensors, and the transmitter interface connects the power distribution and the exciters. The control unit uses the connected exciters to communicate with the amplifiers, the directional coupler and other system modules via CAN bus.

In the exciter configuration, a coder board for baseband processing and an RF board for high-frequency modulation are added to the R&S®TCE900 base unit. The exciter is extremely versatile and can handle the DVB-T, DVB-T2, ISDB-T/ISDB-TB, DTMB and ATSC digital TV standards as well as the DVB-H and ATSC Mobile DTV standards for mobile TV. Equipped with the appropriate coder board, the exciter is ideal for the DAB/DAB+ digital audio broadcast standards and T-DMB Mobile TV applications.

All transmission standards are available as software options for easy retrofitting. It is therefore no problem to install multiple standards in one exciter (e.g. DVB-T and DVB-T2). In addition to the DTV standards, the R&S®TCE900 also supports the analog standards. Due to the system's modularity, only one additional interface board with the analog input interfaces needs to be inserted. A GPS receiver is already integrated and can be activated via option key.

Simple switchover from analog to digital TV

Many operators switch over from analog transmission to digital TV. The R&S®THU9/R&S®THV9 transmitters facilitate this transition. When the exciter is fed with both analog and digital input signals, switchover can take place locally (by pressing a key), remotely or even timed.

IP transport stream feed to reduce infrastructure costs

Due to its cost-effectiveness, IP technology is also gaining ground in broadcast networks. For all digital standards, the R&S®TCE900 exciter offers the option to feed two transport streams redundantly via Gigabit Ethernet interfaces. External IP-to-ASI gateways are no longer required. Because it is integrated in the transmitter control unit, this solution saves money and space and simplifies feed monitoring.

Integrated satellite receiver for fewer components in the rack

A module with two satellite receivers makes it possible to receive up to two DVB-S/DVB-S2 satellite streams without additional external equipment. This saves space in the rack and eliminates investment costs for additional instruments. Encoded streams can be decoded via the two integrated common interface slots. Streams can also be processed outside the transmitter by feeding them to third-party instruments via the integrated IP output or ASI output and returning them via the IP and ASI inputs.

Multifaceted, compact design

Highest power density on the market

Apart from energy costs, infrastructure accounts for the majority of costs incurred during the entire lifecycle of a transmitter system. The R&S®THU9/R&S®THV9 offer the highest power density on the market for solid-state transmitters. Up to twelve amplifiers can be accommodated in a single transmitter rack. This configuration allows an output power of up to 15 kW per rack for the COFDM standards, up to 18.5 kW for ATSC and up to 30 kW for analog TV.

Even more space was saved by integrating further functionalities into the exciter. The R&S®TCE900, for example, offers a GPS receiver and IP interfaces as software options, eliminating the need for external equipment.

MultiTX system with up to four transmitters per rack

The MultiTX concept described above utilizes the high power density of the amplifiers to integrate multiple transmitters into one rack. Depending on the number of amplifiers per transmitter, a rack can hold up to four transmitters. All other transmitters on the market require much more floor space for such a configuration. The decisively smaller footprint of the Rohde & Schwarz solution allows the operator to significantly reduce site rental costs.

Compared with conventional couplers, the horizontally arranged power combiner with built-in coolant distribution saves so much space that four RF rigid lines can be installed. In this way, a rack can accommodate e.g. four transmitters with 3.9 kW output power or three transmitters with 5.2 kW output power.

The transmitter control unit and excitors also require very little space. Up to seven R&S®TCE900 units can be installed in the mounting frame on the top of the transmitter. The vertical arrangement of the equipment, with all interfaces on the top of the transmitter, makes installation and access easy.

The innovative MultiTX design can even increase the compactness of entire N+1 transmitter systems. One rack can accommodate a 3+1 configuration maximally. To save space, the RF coaxial switches are installed directly on the top of the transmitter.

Highest power density per transmitter rack



COFDM TV	15.0 kW
ATV	30.0 kW
ATSC	18.5 kW
DAB	15.0 kW

MultiTX system with four 3.9 kW transmitters in a single rack



All-in-one transmitter with built-in pump unit and bandpass filter

The high power density also has advantages for all-in-one configurations. For UHF transmitters with up to four amplifiers, both the pump unit and a six-cavity bandpass filter can be integrated into the rack. This approach also reduces the space required for a single transmitter. The hydraulic components of the pump are installed in the rear part of the transmitter rack and can easily be accessed via the rear door.

Space-saving, flexible liquid cooling system

The external cooling system also requires less space than comparable systems. With its compact hydraulic block, the pump unit fits into a minimum of space. The smart frame design helps to ensure installation flexibility. The pump can be installed on the floor (standard solution) or on the wall. Two pumps can also be stacked on one another.

The practice-proven design of the heat exchangers was also improved. Changing the arrangement of the robust stainless-steel registers made the heat exchangers even more compact. Depending on the site constraints, the heat exchangers can be installed vertically or horizontally. The transmitter's high efficiency ensures low power dissipation, further reducing the size of the heat exchangers.

All-in-one system in a single rack



2+1 system, 5.2 kW each, in a single rack



Simple operation for fast results

Ergonomic, user-friendly operating unit

The R&S®TDU900 was designed with easy access, operating convenience and ergonomics in mind. The retractable display is installed above the amplifiers and automatically slides out when the user gives it a slight push. The user can then conveniently turn the display to the desired position to operate the transmitter while standing up or sitting down. The seven-inch display unit has a touchscreen and LEDs that indicate the system status. An Ethernet port is provided for exchanging configuration data.

Simplified navigation with device-oriented views

The GUI is straightforward and makes it possible to check the system status at a glance. The transmitter system's structure is displayed graphically; touching the transmitter components on the touchscreen provides direct access to the related parameters.

The left-hand side of the screen permanently displays frequently required central functions. Using these softkeys, it is possible to check the logbook and switch between local and remote control. Activating the help function gives access to additional information about the specific components.



R&S®TDU900 transmitter display unit.

It is possible to switch between different user profiles and between device and task-oriented views. The screen content on the right-hand side changes according to the selected components. The system navigation path at the bottom of the screen allows the user to quickly change from one parameter to another. When accessing the transmitter via web interface, the same user interface appears in the web browser.

Task-oriented menus for fast training of operating personnel

Depending on the system status, the operator must perform different tasks on the transmitter, ranging from simple monitoring tasks to complex commissioning procedures. The task-oriented menu view adapts the user interface to the different requirements. The tasks and their individual steps are clearly displayed on the GUI so that they can be accomplished in a minimum of time. When putting the transmitter into operation, for example, the operator is guided through the configuration of the different devices and given help when entering parameters and adapting settings.

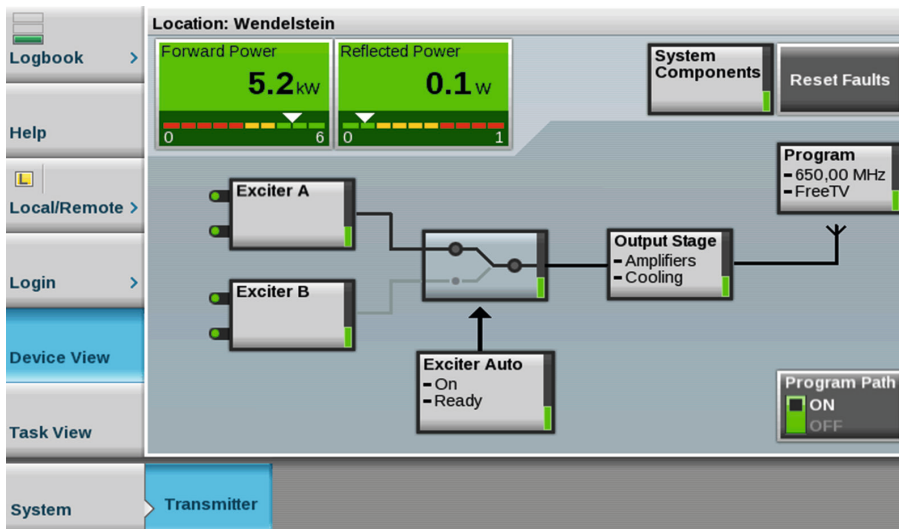

Device-oriented view.

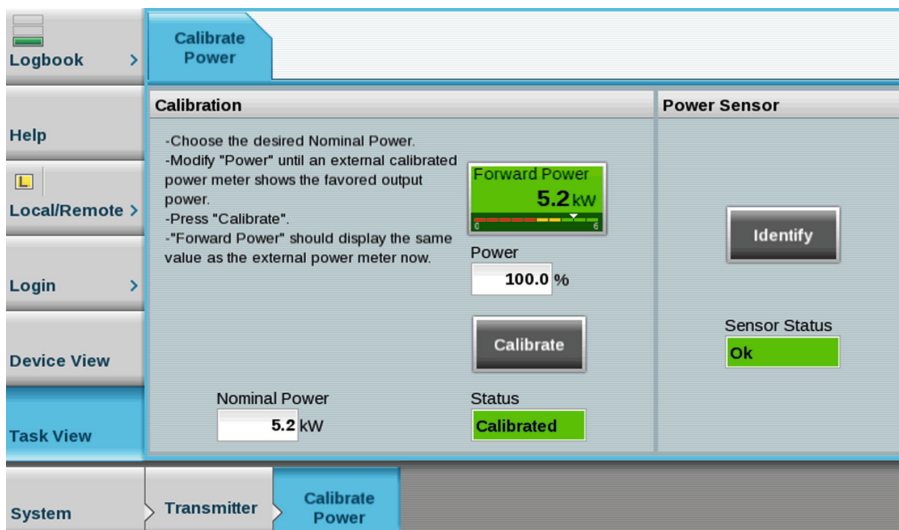

Task-oriented view.

Specifications

Specifications		
Digital TV		
Standards		DVB-T, DVB-T2, DVB-H, ISDB-T, ISDB-T _B , ATSC, ATSC Mobile DTV, DTMB
Channel bandwidth	DVB-T, DVB-H	5/6/7/8 MHz
	DVB-T2	1.7/5/6/7/8 MHz
	ISDB-T, ISDB-T _B	6 MHz
	ATSC	6 MHz
	DTMB	6/8 MHz
Inputs	DVB-T, DVB-H	2 × ASI (HP/LP), 75 Ω BNC, 2 × RJ-45
	DVB-T2	2 × ASI (HP/LP), 75 Ω BNC, 2 × RJ-45
	ISDB-T, ISDB-T _B	2 × BTS, 75 Ω BNC, 2 × RJ-45
	ATSC	2 × SMPTE310M or 2 × ASI, 75 Ω BNC, 2 × RJ-45
	DTMB	2 × ASI (HP/LP), 75 Ω BNC, 2 × RJ-45
Digital audio broadcasting/Mobile TV in the VHF range		
Standards		DAB, DAB+, T-DMB
Channel bandwidth		1.5 MHz
Inputs		2 × ETI, 75 Ω BNC/high impedance, 2 × EDI, RJ-45
Analog TV		
Standards		B/G, D/K, M ¹⁾ , N ¹⁾ , I, 11
Color transmission		PAL, NTSC, SECAM
Sound transmission		IRT dual-sound coding, FM single sound and NICAM728 (−13 dB/−20 dB), FM single sound (−10 dB)
Inputs		1 × video (75 Ω BNC), 2 × audio (XLR)
General data		
Frequency range	UHF band IV/V	470 MHz to 862 MHz
	VHF band III	170 MHz to 254 MHz
Supply voltage		400 V/230 V; 4 wires + PE (L1/L2/L3/N/PE) ± 15%, 208 V; 3 wires + PE (L1/L2/L3/PE) ± 15%, 220 V; 3 wires + PE (L1/L2/L3/PE) ± 15%, 240 V; 3 wires + PE (L1/L2/L3/PE) −15%/+10%
Max. installation height		2000 m above sea level (> 2000 m on request)
Operating temperature range		+1 °C to +45 °C
Relative humidity (max.)		95%, noncondensing
Immunity ²⁾	to fast transients and burst in line with IEC 61000-4-4	< 4 kV (AC supply), < 1 kV (signal inputs)
	to surges in line with IEC 61000-4-5	symmetrical < 2 kV (e.g. L1-L2), asymmetrical < 4 kV (e.g. L1-N)
Synchronization		
Reference frequency		10 MHz, 0.1 V to 5 V (V _{pp}) or TTL, BNC
Reference pulse		1 Hz, TTL, BNC
Operation		
Display unit with touchscreen and LEDs		local operation and display
Ethernet interface, RJ-45		local, remote, standard web browser
	optional	network management interface via SNMP
Parallel remote interface	optional	floating contacts for messages and commands

¹⁾ Only single sound.

²⁾ With built-in AC supply overvoltage protection; more stringent requirements must be satisfied by implementing appropriate measures in the station.

To comply with the applicable standards and limit values for the suppression of out-of-band emissions (and in the case of digital standards, also for maintaining the required shoulder distance), the transmitter may only be operated with suitable filters at the RF output.

From pre-sale to service. At your doorstep.

The Rohde&Schwarz network in over 70 countries ensures optimum on-site support by highly qualified experts. User risks are reduced to a minimum at all stages of the project:

- ▮ Solution finding/purchase
- ▮ Technical startup/application development/integration
- ▮ Training
- ▮ Operation/calibration/repair



Ordering information

Your local Rohde&Schwarz expert will help you determine the optimum solution for your requirements. To find your nearest Rohde&Schwarz representative, visit www.sales.rohde-schwarz.com

Service that adds value

- ▮ Worldwide
- ▮ Local and personalized
- ▮ Customized and flexible
- ▮ Uncompromising quality
- ▮ Long-term dependability

Rohde & Schwarz

The Rohde & Schwarz electronics group offers innovative solutions in the following business fields: test and measurement, broadcast and media, secure communications, cybersecurity, monitoring and network testing. Founded more than 80 years ago, the independent company which is headquartered in Munich, Germany, has an extensive sales and service network with locations in more than 70 countries.

Sustainable product design

- ▮ Environmental compatibility and eco-footprint
- ▮ Energy efficiency and low emissions
- ▮ Longevity and optimized total cost of ownership

Certified Quality Management

ISO 9001

Certified Environmental Management

ISO 14001

Rohde & Schwarz GmbH & Co. KG

www.rohde-schwarz.com

Rohde & Schwarz training

www.training.rohde-schwarz.com

Regional contact

- ▮ Europe, Africa, Middle East | +49 89 4129 12345
customersupport@rohde-schwarz.com
- ▮ North America | 1 888 TEST RSA (1 888 837 87 72)
customer.support@rsa.rohde-schwarz.com
- ▮ Latin America | +1 410 910 79 88
customersupport.la@rohde-schwarz.com
- ▮ Asia Pacific | +65 65 13 04 88
customersupport.asia@rohde-schwarz.com
- ▮ China | +86 800 810 82 28 | +86 400 650 58 96
customersupport.china@rohde-schwarz.com

R&S® is a registered trademark of Rohde & Schwarz GmbH & Co. KG

Trade names are trademarks of the owners

PD 5214.5990.12 | Version 05.04 | March 2018 (fi)

R&S®THU9/R&S®THV9 Liquid-cooled transmitter families

Data without tolerance limits is not binding | Subject to change

© 2011 - 2018 Rohde & Schwarz GmbH & Co. KG | 81671 Munich, Germany



5214599012