

# R&S® AREG100A AUTOMOTIVE RADAR ECHO GENERATOR



Reliable and simple production testing  
of automotive radar sensors



Product Brochure  
Version 03.01

**ROHDE & SCHWARZ**

Make ideas real



# YOUR CHALLENGE

Sensors based on radar technology are key components of advanced driver assistance systems (ADAS). Due to this and the strong trend towards more and more autonomously driving cars, the number of radar-based systems per car is increasing. This means there are more sensors on the road, leading to the need for a reliable test concept in sensor mass production.

Radar sensor makers face numerous challenges in high-volume manufacturing:

- ▶ Fast, reliable and accurate end-of-line testing to ensure continuous product quality control
- ▶ Simple and flexible test solutions that fit their needs
- ▶ Testing long range radar (LRR) sensors and short range radar sensors (SRR)
- ▶ Testing sensors with radar bandwidths up to 4 GHz in the E band and up to 250 MHz in the ISM band
- ▶ Verifying compliance of the radar sensors with all relevant normative standards that became law in Europe within the Radio Equipment Directive (RED) framework.

OEMs face the following challenges in final inspection tests before a car is delivered to the end user:

- ▶ Making sure that sensors are properly integrated into the bumpers of the car
- ▶ Making sure that all sensors illuminate their sector correctly

## Ready for RED – simple and repeatable interferer generation

An automotive radar sensor's immunity to interferers is one of its key performance indicators. Interfering signals can originate from transmit signals from oncoming traffic. High robustness against interferers is a prerequisite for safe rides.

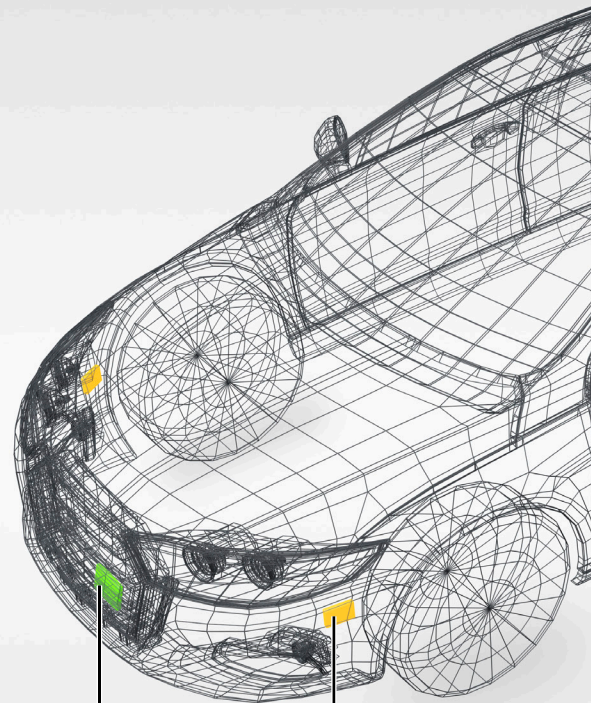

## Monitoring the quality of radar sensors in mass production

Long range radar sensors (LRR) are installed in the front of a car and are used to detect objects at a range of 200 m and beyond. These sensors provide services such as adaptive cruise control and traffic jam assist. An additional four to six SRR sensors are installed in the corners and the B pillars of a car. They provide services such as blind spot detection and lane change assist and form a 360° radar cocoon around the car. For continuous product quality control in manufacturing, a reliable and flexible tester that supports all radar bands is needed. To handle tomorrow's SRR sensor tests, it must simulate echoes from objects at a minimum distance and also support an instantaneous bandwidth up to 4 GHz in the E band.

# OUR SOLUTION

## Ready for RED – precise EIRP measurement

Automotive radar sensor transmitters must comply with the applicable RED standards. Sensors must not exceed transmit power limitations, and transmit signals must stay within the spectrum emission mask for occupied bandwidth and unwanted emissions.

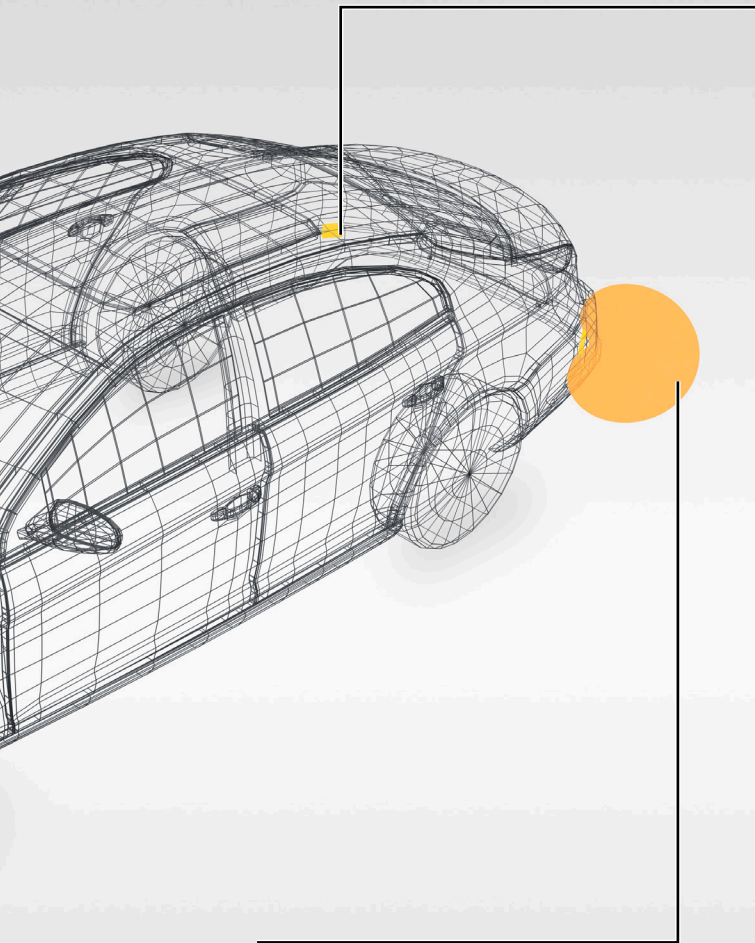

## Verifying correct installation of radar sensors

The sensor must be mounted correctly in order for the sensor's antenna to illuminate its sector and for its boresight direction to be aligned correctly within the car's coordinate system.

Rohde & Schwarz offers system and test engineers the R&S®AREG100A automotive radar echo generator, a powerful tester for today's and tomorrow's automotive radar sensors. It has been designed especially for production testing of automotive radar sensors.

## Reliable and flexible echo generation

- ▶ Install up to four different, user-defined fixed delay lines to simulate unrelated object echoes
- ▶ Simulate echoes with minimum delay for SRR sensor tests
- ▶ Simulate echoes for LRR sensor tests
- ▶ Select additional Doppler offsets to simulate individual radial velocity for each artificial object or for all artificial objects together

## Test today's and tomorrow's radar sensors

- ▶ Choose a 24 GHz ISM band frontend or an E-band frontend
- ▶ Benefit from a future-proof, wideband E-band frontend with 4 GHz instantaneous bandwidth for SRR tests of sensors with FMCW and I/Q modulated signals

## Ready for RED

- ▶ Measure the sensor's equivalent radiated isotropic power (EIRP) in line with the applicable standards – with a connected R&S®NRP8S(N) power sensor
- ▶ Verify robustness of radar sensors to in-band interferers – with a connected analog or vector signal generator
- ▶ Measure occupied bandwidth and unwanted emissions – with a connected signal and spectrum analyzer

## Simple and stable operation

- ▶ Linux-based operating system for maximum software stability
- ▶ Optimized for minimal footprint of just 3 HU
- ▶ SCPI macro recorder with automatic code generator
- ▶ Intuitive GUI for user-friendly operation

# AT A GLANCE

The R&S®AREG100A automotive radar echo generator is a smart, robust solution for testing automotive radar sensors in production. The R&S®AREG100A gives production engineers the advantage of test case flexibility combined with simple and robust operation. Up to four fixed delay lines can be installed. Test engineers define the length of the fixed delay lines at the time of order, for maximum test case flexibility and a cost-optimized tester. A fully calibrated delay path throughout the tester, including the frontend, ensures maximum accuracy of the inserted delay. An additional Doppler offset can either be applied to each object individually or to all objects together to simulate radial velocities.

Thanks to the R&S®AREG100A and the company's experience in mmWave technology, OEMs and Tier1 sensor suppliers benefit from innovative frontend designs for the 24 GHz ISM band and E band. The E-band frontend is available from 76 GHz to 77 GHz for testing long range radar sensors and from 76 GHz to 81 GHz for testing today's state-of-the-art long range radar sensors and tomorrow's most advanced short range radar sensors with an instantaneous bandwidth up to 4 GHz. Calibrated IF input and output ports are available to connect additional T&M equipment such as R&S®NRP power sensors to perform measurements in line with RED.

## Reliable and flexible echo generation

- ▶ Simulation of up to four individual radar echoes
- ▶ Testing of short range radar sensors with a single static object at 4 m distance
- ▶ Up to three additional static objects with a selectable distance between 5 m and 300 m for testing medium range and long range radars
- ▶ Objects can be switched on or off individually and as a group
- ▶ Doppler offsets can be applied to all static objects to simulate radial velocity, e.g. for testing static object suppression of moving target indicator (MTI) radars
- ▶ Individual control of radar echoes' amplitude
- ▶ Simulate a wide range of radar cross sections (RCS) with up to 55 dB difference in the RCS value between individual objects



## Simple and stable operation

- ▶ Simple man-machine interface with intuitive GUI for user-friendly configuration
- ▶ Touchscreen control makes the echo generator easy to operate – reconfiguration of the parameters is possible with just a single touch
- ▶ Linux-based operating system provides maximum software stability for 24/7 test operation
- ▶ SCPI macro recorder with automatic code generator creates an executable MATLAB® script from recorded manual settings
- ▶ Standard remote control interfaces such as Ethernet, USB and GPIB are supported

## Ready for RED – simple and repeatable interferer generation

- ▶ Input interface for interferer signals in the intermediate frequency range
- ▶ Any Rohde & Schwarz analog or vector signal generator can be used in combination with the R&S®AREG100A to simulate a wide range of interferers together with the wanted echoes
- ▶ A signal generator with a maximum RF frequency of up to 6 GHz is all that is needed
- ▶ R&S®AREG100A takes care of upconversion into the respective radar band
- ▶ Simple and convenient testing with reduced cost per test

## Ready for RED – precise EIRP measurement

- ▶ Simple and easy measurement of the equivalent isotropic radiated power (EIRP) of automotive radar sensors.
- ▶ Frontend downconverts the received radar transmit signal from the E band or the ISM band and provides it to a connected R&S®NRP8S(N) power sensor
- ▶ Great simplification of the test setup since the frontend provides an extra IF output port
- ▶ Thanks to a fully calibrated receive path, the user can directly read the true radar EIRP on the R&S®AREG100A display
- ▶ Accurate measurement of the EIRP in line with the applicable standards as defined in RED, e.g. ETSI EN 301091-1



## Test today's and tomorrow's radar sensors

- ▶ R&S®AREG100A is available with RF frontends in the 24 GHz, 76 GHz and 79 GHz automotive radar bands
- ▶ Ideal solution for testing today's and tomorrow's radar sensors in production with instantaneous bandwidths of up to 4 GHz
- ▶ All frontends are available in a single-antenna configuration for superior MIMO testing performance or in a two-antenna configuration with high RX/TX isolation for lowest ringaround
- ▶ Highest test case flexibility through sequential use of 24 GHz or 76 GHz frontends with a single base unit
- ▶ Cable connection to the base unit for simple integration into an anechoic chamber

# MONITOR THE QUALITY OF RADAR SENSORS IN MASS PRODUCTION

## Testing automotive radar sensors in production

The R&S®AREG100A is a reliable and flexible production tester for automotive radar sensor manufacturing. It enables continuous product quality control and helps identify faulty sensors.

Up to four separate fixed objects can be installed individually for true test case flexibility. The user can select user-definable fixed delay lines at the time of order. The object size and the Doppler offset can be configured. The RCS value describes the size of the object, and the Doppler offset simulates radial velocities. This concept gives production test engineers a flexible, yet robust and simple solution.

The R&S®AREG100A receives the radar transmit signal from the radar under test. It downconverts the signal to the intermediate frequency (IF) and introduces a fixed time delay (range), radial velocity (Doppler frequency shift) and attenuation to the received radar signal. The IF signal is then upconverted to the RF and transmitted back to the radar under test. The radar under test receives and processes this modified version of the signal that it originally transmitted and reports the detected range, Doppler offset and radar cross section (RCS).

## Testing in shielded anechoic chambers

A combination of the R&S®AREG100A and the R&S®ATS1500C antenna test chamber provides a protected RF environment for accurate and repeatable testing of automotive radar sensors. The sensor is placed in a test fixture that can be remotely controlled. The radar echo generator and shielded chamber offer an optimized footprint and are a perfect combination.

## Test automation

The powerful R&S®QuickStep test executive software is fully harmonized with Rohde&Schwarz T&M equipment and provides flexibility for developing new test procedures, test automation and report generation. It simplifies and improves test development and minimizes the effort involved in defining test routines.

## The R&S®AREG100A introduces a time delay, attenuation and Doppler frequency shift to generate artificial echoes for a DUT

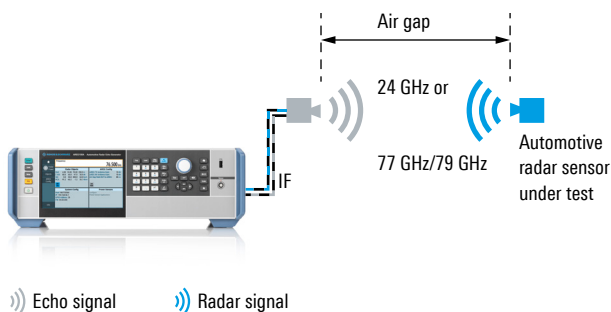

The R&S®AREG100A in combination with the R&S®ATS1500C antenna test chamber is a low-footprint test solution



# VERIFY CORRECT INSTALLATION OF RADAR SENSORS

## Radar sensor validation during final inspection on automotive assembly lines

To ensure the satisfaction of new car buyers and to reduce the OEM's necessary after sales service, radar-based ADAS sensors have to work as intended when the car leaves the production line. After the automotive radar sensors are integrated into the car bumpers, it is extremely important to test the proper functioning and initialization of ADAS sensors during final in-depth testing at the end of the automaker's assembly line.

Typically cars have one LRR sensor for adaptive cruise control and multiple SRR sensors for collision avoidance systems. All long range radar sensors and short range radar sensors installed in a car are examined.

The car is placed on a dynamometer. After the car is precisely aligned, the initialization and testing procedure is executed. OEMs use this test to crosscheck that the sensor is correctly integrated into the bumpers to ensure that the antennas illuminate their defined sectors. The car passes the test if the received power level of the radar echo is within a certain range of the expected value.

## Solution for parallel short range radar testing

Cars typically use multiple short range radar sensors for their collision avoidance systems. Using several R&S®AREG100A generators (one for each installed radar sensor in the car) allows simultaneous testing. Sensors are typically installed in the front corners, in the back corners and in the B pillars of the cars.

Parallel testing of automotive radar sensors provides OEMs with a simple and lean way to optimize the production sequence as well as to condense and minimize test-cycle times.

To support parallel testing, an independent Doppler frequency shift can be configured in any of the R&S®AREG100A generators. An individual, artificial radar object with unique velocity is generated for each radar sensor. Unwanted echoes from multipath propagation, such as radar echoes with different Doppler offsets from other test stands or due to parallel testing, can be gated out if the radar sensor under test and the R&S®AREG100A are configured with the same unambiguous and identical Doppler offset. This prevents falsified sensor test results, and tests can be executed simultaneously.

## Final initialization and functionality testing of the short range radar sensors used by the ADAS. The R&S®AREG100A is the perfect solution for final inspection on all automakers' assembly lines.

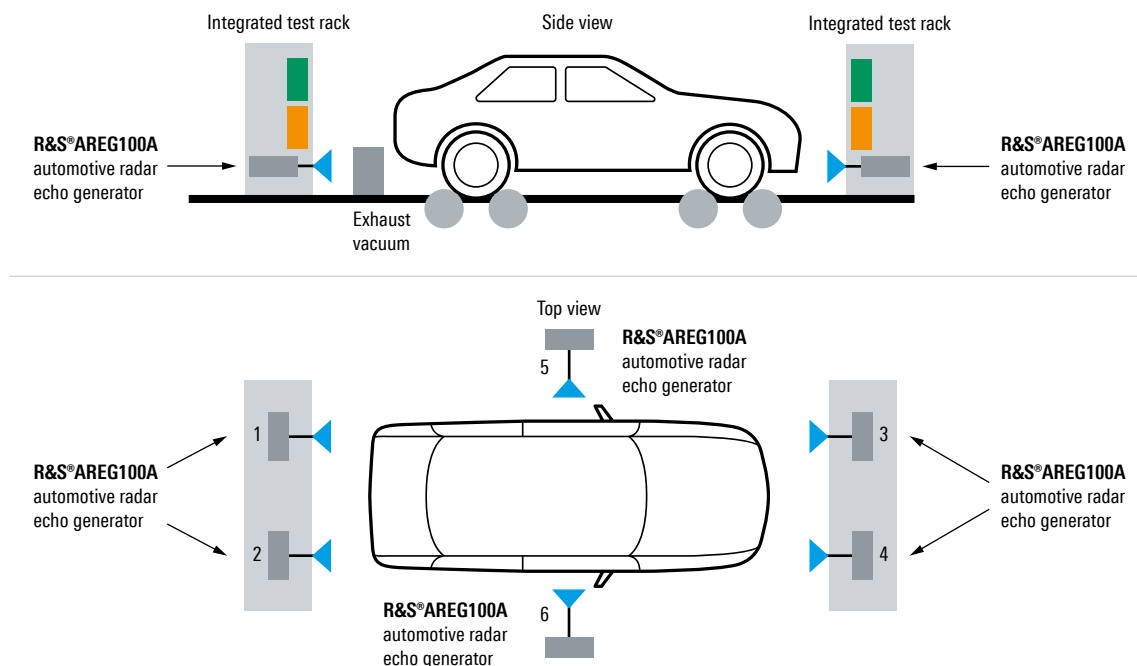

# READY FOR RED – PRECISE EIRP MEASUREMENT

## Accurate measurement of the radar sensor's EIRP

The calibrated IF output ports of the R&S®AREG100A make it possible to test the automotive radar sensors in line with the applicable standards defined by RED, e.g. ETSI EN301091-1 or ETSI EN302264-1. The R&S®AREG100A takes care of the downconversion from the ISM or the E band to the intermediate frequency and simplifies the setup. Thanks to the calibrated receive path, a connected R&S®NRP8S/SN power sensor can accurately measure the radar sensor's equivalent isotropic radiated power (EIRP).

The calculation of the automotive radar sensor's EIRP is performed entirely by the R&S®AREG100A. The EIRP value is displayed in the GUI of the base unit. Operators or automated test routines can immediately identify deviations of the measured EIRP from the expected value to sort out faulty sensors. This makes the testing of the radiated power level fast and easy.

## Spurious emissions and spectral mask measurements

Spurious emissions and the spectral mask can be measured as defined in the applicable standards. With the R&S®AREG100A, the measurements can be performed at the intermediate frequency range using a second calibrated IF output port available at the base unit.

The R&S®AREG100A with a connected R&S®FSW8 signal and spectrum analyzer can measure the key parameters of the radar transmit signal from the DUT, such as:

- ▶ Occupied bandwidth
- ▶ Chirp linearity
- ▶ Chirp duration

Within one measurement cycle, the measurements can be performed parallel to the echo generation. This makes the characterization of automotive radar sensors simple and straightforward.

The R&S®AREG100A and the R&S®FSW8 are the perfect team for efficient measurement of radar signal parameters in the E band

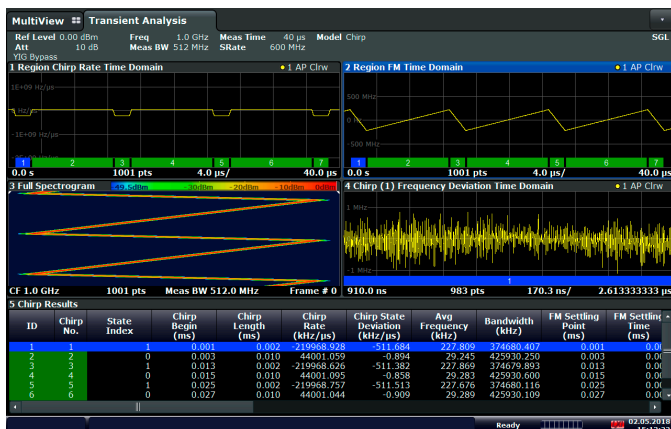

The EIRP of an automotive radar sensor, measured by an R&S®NRP8S(N), is directly displayed on the R&S®AREG100A GUI

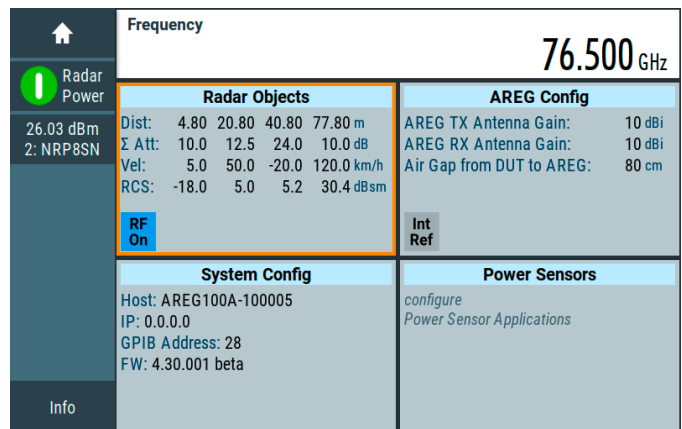



# READY FOR RED – SIMPLE AND REPEATABLE INTERFERER GENERATION

## Testing the radar sensor's immunity to interfering signals

Drivers rely more and more on radar-based advanced driver assistance systems (ADAS). The radar sensor delivers information about the surrounding traffic environment. It is a must for every radar sensor to detect wanted signals from real objects, even in the presence of unwanted interferers. RED has been mandatory in Europe since June 2017. It requires testing the robustness of automotive radar sensors to in-band and out-of-band CW interferers.

## Rohde & Schwarz test solution

With the R&S®AREG100A, Rohde & Schwarz offers a smart and simple solution for testing the robustness of automotive radar sensors to in-band interferers as defined in RED.

By providing an input interface in the IF domain, any analog or vector signal generator can be used in combination with the R&S®AREG100A to simulate a wide range of interferers together with the wanted echoes. To generate interferers, all that is needed is a 6 GHz RF signal generator. This saves cost and makes testing simple and easy. The user can fully focus on test execution.

The generated interfering signal is superimposed onto the echo signals and upconverted into the ISM band or E band together with the delayed echo signal from the simulated objects of the radar under test.

## Advanced interferer testing

For simulation of complex FM chirp sequences, simulation software such as the R&S®Pulse Sequencer software plus an R&S®SMW200A is a good choice. This makes it possible to simulate any kind of interference scenario.

## Rohde & Schwarz reference solution for reliably testing the robustness of automotive radar sensors to in-band interferers as defined by RED

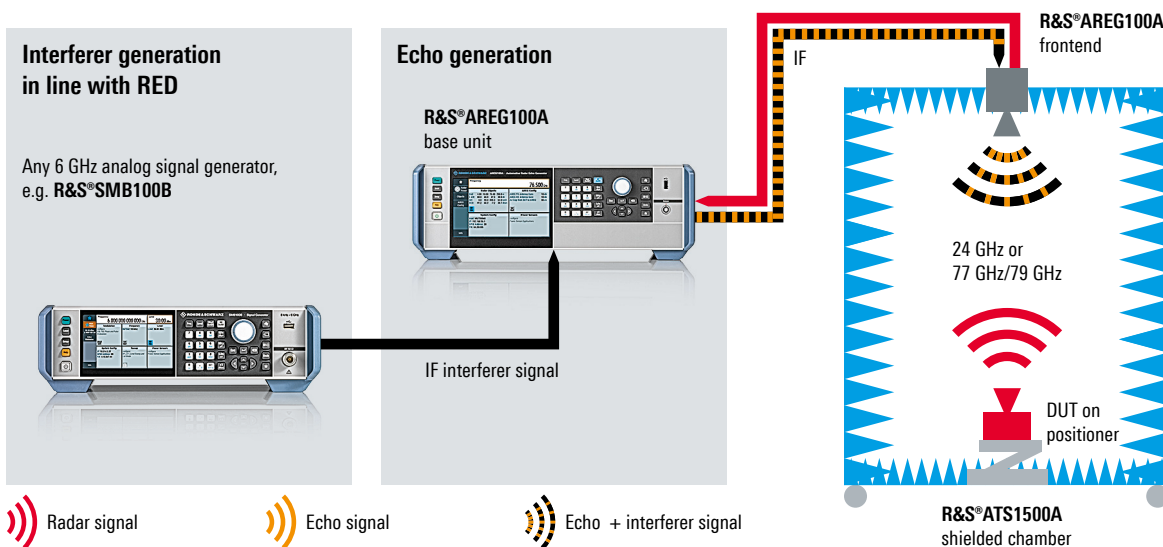

# SYNERGY AT A GLANCE

The R&S®AREG100A automotive radar echo generator is the core element for performing radar tests at the end of production lines.

To fulfill the test and measurement tasks in a simple and convenient way, the R&S®AREG100A in combination with additional Rohde & Schwarz T&M equipment is a tailored solution for testing radar sensors. Leading T&M vendor Rohde & Schwarz provides production engineers a harmonized portfolio of T&M equipment for radar sensor production tests.



## Power sensor

Choose an R&S®NRP power sensor to accurately test the radar sensor's conformance with applicable transmit power limitations, such as defined by RED. You can directly connect the power sensor to the remote frontend of the R&S®AREG100A and benefit from the calibrated receive path.



## Shielded chambers and positioner

Thanks to the R&S®ATS1500C antenna test chamber, repeatable tests of radar sensor can be performed in a shielded environment with a small footprint:

- ▶ Accurate measurement of the antenna pattern with power sensor and additional positioner
- ▶ Fast and simple definition of test routines thanks to the R&S®QuickStep test executive software



### Signal generators

Choose a Rohde & Schwarz analog signal generator or the industry-leading R&S®SMW200A vector signal generator to generate interferer signals:

- ▶ Perform in-band interference testing with CW signals in line with RED
- ▶ Perform advanced interference testing with a vector signal generator and the R&S®Pulse Sequencer software



### Signal and spectrum analyzers

Benefit from fast analysis of radar sensors parameters with the R&S®FSW8 signal and spectrum analyzer. You can easily analyze radar sensors signal parameters such as:

- ▶ Occupied bandwidth
- ▶ Chirp sequence
- ▶ Chirp linearity

# FROM PRE-SALE TO SERVICE. AT YOUR DOORSTEP.

The Rohde & Schwarz network in over 70 countries ensures optimum on-site support by highly qualified experts.

User risks are reduced to a minimum at all stages of the project:

- ▶ Solution finding/purchase
- ▶ Technical startup/application development/integration
- ▶ Training
- ▶ Operation/calibration/repair



# SPECIFICATIONS IN BRIEF

Specifications in brief		
<b>Frequency</b>		
Frequency range	R&S®AREG-B124S/-B124D	24.0 GHz to 24.25 GHz, single or dual antenna
	R&S®AREG-B177S/-B177D	76.0 GHz to 77.0 GHz, single or dual antenna
	R&S®AREG-B181S/-B181D	76.0 GHz to 81.0 GHz, single or dual antenna
<b>Signal bandwidth</b>		
Instantaneous bandwidth	R&S®AREG-B124S/-B124D	250 MHz
	R&S®AREG-B177S/-B177D	1 GHz
	R&S®AREG-B181S/-B181D	4 GHz from 76 GHz to 81 GHz (configurable: either 76 GHz to 80 GHz or 77 GHz to 81 GHz)
<b>Artificial objects</b>		
Object type		fixed distance
Total number of objects		4
Object distances with R&S®AREG-B61	up to one R&S®AREG-B61 option	3.2 m (nom.) + air gap
Object distances with R&S®AREG-B62	up to three R&S®AREG-B62 options, desired distance (incl. air gap) for each option must be specified during the ordering process along with the desired air gap valuedistance	4.2 m to 299.2 m (nom.) + air gap
Air gap	The distance between frontend reference plane and DUT must be defined at time of ordering. A change after ordering is possible, but object distances and resulting object radar cross sections will change accordingly.	recommendation: air gap should be large enough to match far field condition of radar under test
<b>Radial velocity</b>		
Doppler frequency shift	with R&S®AREG-K799 Doppler frequency shift, for all artificial objects together	yes
Individual Doppler frequency shift	with R&S®AREG-B60 Doppler frequency shift, for each artificial object individually	yes
Velocity setting range	R&S®AREG-B60 and R&S®AREG-K799	±500 km/h
<b>Level</b>		
Absolute maximum RX power at frontend RX waveguide port	R&S®AREG-B124S/-B124D	0 dBm (nom.)
	R&S®AREG-B177S/-B177D	-7 dBm (nom.)
	R&S®AREG-B181S/-B181D	-7 dBm (nom.)
Maximum TX power at frontend TX waveguide port	R&S®AREG-B124S/-B124D	≥ 15 dBm (meas.)
	R&S®AREG-B177S/-B177D	≥ 20 dBm (meas.)
	R&S®AREG-B181S/-B181D	≥ 18 dBm (meas.)
Receive/transmit gain control setting range	all artificial objects together	> 90 dB (meas.)
	each object individually	55 dB (meas.)
Receive/transmit gain control step size		0.5 dB (nom.)
<b>IF input/IF output</b>		
IF input/output interfaces	with R&S®AREG-B17 option	calibrated IF outputs on frontend and base unit calibrated IF input on base unit
IF input gain	from auxiliary TX IF In port (at IF frequency) to frontend TX waveguide output (at RF frequency)	
	R&S®AREG-B124S/-B124D, RF frequency = 24.125 GHz	20 dB (meas.)
	R&S®AREG-B177S/-B177D, RF frequency = 76.5 GHz	20 dB (meas.)
	R&S®AREG-B181S/-B181D, RF frequency = 78 GHz or 79 GHz	20 dB (meas.)
IF input compression P1dB	level at TX IF In port (at IF frequency)	
	R&S®AREG-B124D	1 dBm (meas.)
	R&S®AREG-B177D	1 dBm (meas.)
	R&S®AREG-B181D	-5 dBm (meas.)
<b>Connectivity</b>		
Remote control		Ethernet
	with R&S®AREG-B86 option	GPIO, USB

# ORDERING INFORMATION

R&S®AREG-Bxxx = hardware option

R&S®AREG-Kxxx = software/keycode option

Designation	Type	Order No.
<b>Base unit</b>		
Automotive radar echo generator, including power cable, quick start guide	R&S®AREG100A	1430.3508.02
<b>Options</b>		
Frontend frequency and antenna configuration		
24 GHz to 24.25 GHz, single antenna	R&S®AREG-B124S	1430.5000.02
24 GHz to 24.25 GHz, two antennas	R&S®AREG-B124D	1430.5100.02
76 GHz to 77 GHz, single antenna	R&S®AREG-B177S	1430.5752.02
76 GHz to 77 GHz, two antennas	R&S®AREG-B177D	1430.5700.02
76 GHz to 81 GHz, single antenna	R&S®AREG-B181S	1430.5052.02
76 GHz to 81 GHz, two antennas	R&S®AREG-B181D	1430.5152.02
Fixed distance options		
Short fixed object distance, 3.2 m + air gap	R&S®AREG-B61	1430.5317.02
Fixed object distance, customer defined	R&S®AREG-B62	1430.5369.02
Radial velocity		
Frequency offset	R&S®AREG-K799	1437.2488.02
Doppler simulation	R&S®AREG-B60	1430.5552.02
Interface options		
Analog IF interface	R&S®AREG-B17	1430.5200.02
Remote control, GPIB and USB	R&S®AREG-B86	1430.5252.02
<b>Recommended extras</b>		
Three-path diode power sensor	R&S®NRP8S	1430.5600.02

## Warranty

Base unit and frontends	3 years
All other items <sup>1)</sup>	1 year

## Options

Extended warranty, one year	R&S®WE1	
Extended warranty, two years	R&S®WE2	Please contact your local
Extended warranty with calibration coverage, one year	R&S®CW1	Rohde & Schwarz sales office.
Extended warranty with calibration coverage, two years	R&S®CW2	

<sup>1)</sup> For options that are installed, the remaining base unit warranty applies if longer than 1 year. Exception: all batteries have a 1 year warranty.

## Service that adds value

- ▶ Worldwide
- ▶ Local and personalized
- ▶ Customized and flexible
- ▶ Uncompromising quality
- ▶ Long-term dependability

## Rohde & Schwarz

The Rohde & Schwarz electronics group offers innovative solutions in the following business fields: test and measurement, broadcast and media, secure communications, cybersecurity, monitoring and network testing. Founded more than 80 years ago, the independent company which is headquartered in Munich, Germany, has an extensive sales and service network with locations in more than 70 countries.

[www.rohde-schwarz.com](http://www.rohde-schwarz.com)

## Sustainable product design

- ▶ Environmental compatibility and eco-footprint
- ▶ Energy efficiency and low emissions
- ▶ Longevity and optimized total cost of ownership

Certified Quality Management  
**ISO 9001**

Certified Environmental Management  
**ISO 14001**

## Rohde & Schwarz training

[www.training.rohde-schwarz.com](http://www.training.rohde-schwarz.com)

## Rohde & Schwarz customer support

[www.rohde-schwarz.com/support](http://www.rohde-schwarz.com/support)

