



Products: R&S[®] NV7000, R&S[®] NV7001, R&S[®] NV8200, R&S[®] SV7000, R&S[®] SV7002, R&S[®] SV8000 DTV transmitters, R&S[®] EFA, R&S[®] FSP, R&S[®] FSU test instruments

The Crest Factor in DVB-T (OFDM) Transmitter Systems and its Influence on the Dimensioning of Power Components

Application Note 7TS02

Are there really power peaks that are 20 dB above the average value? Yes, there are. Ever since the introduction of digital transmission technology, it has been necessary to deal with such orders of magnitude. RF power components must be suitably dimensioned to handle the expected voltage peaks and avoid breaking down. If we can determine the crest factor, i.e. the ratio of the peak value to the average or RMS value, with sufficient accuracy (even though it can only be assessed statistically), then we will have solved the question of dimensioning power components. This Application Note is intended to help with this problem by providing some useful insights including basic formulas, some statistical background and a practical look at the limiting factors when it comes to dealing with real transmitter systems.



Contents

| | | |
|---|---|----|
| 1 | Introduction | 2 |
| 2 | Determination and Usage of the Crest Factor | 3 |
| | The crest factor of a modulated RF signal..... | 3 |
| | Crest factor for multiple superimposed signals..... | 5 |
| | Crest factor measurement | 6 |
| | Output signal from a DVB-T transmitter..... | 9 |
| | Output bandpass..... | 11 |
| | Interconnection of multiple transmitters on an antenna..... | 12 |
| 3 | The Crest Factor During Generation of a DVB-T Signal | 17 |
| | Signal generation in the baseband | 17 |
| | Modulation of the carrier frequency | 20 |
| 4 | Summary..... | 23 |
| | Envelope approach | 23 |
| | Carrier approach..... | 23 |
| | Specification of the crest factor..... | 24 |
| | The crest factor in large transmitter systems..... | 24 |
| 5 | References..... | 25 |
| 6 | Additional information | 25 |

1 Introduction

Many new transmitter systems are currently being set up as part of the conversion to digital terrestrial television. As a result of the use of OFDM modulation, high crest factors occur in the RF signal that lie well above the values that occur in analog transmitters. For an individual transmitter, it is possible to limit this ratio of the peak power to the average (thermal) output power. However, if we interconnect several transmitters, an increase will occur with each additional transmitter. Depending on the transmitter system, the peak power levels can reach values of more than one hundred times the thermal power level. Accordingly, the dimensioning of the RF power components in a transmitter system (antenna combiners, coaxial lines and antennas) can no longer be based solely on thermal criteria. Short voltage peaks that occur only very rarely in statistical terms are often critical in determining the size and shape of these RF components.

When it comes to determining crest factors, there are several measurement methods in addition to the actual computation that can produce seemingly divergent results due to their different approaches.

In particular, measurement of high crest factor values over 12 dB (P_{PEP}/P_{AVG}) tends to be very problematic. Statistical effects often come into play in addition to the limited dynamic range. Due to the measurement time that would be required, power peaks that occur only every week, month or year in accordance with their statistical probability cannot be assessed using ordinary test means.

When considering low-amplitude signals in terms of their BER, MER and intermodulation products, high crest factors are irrelevant. However, this is not the case on the power end of things. Here, high voltages associated with power peaks can produce a flashover and possibly a standing arc in the transmitter system.

The seemingly divergent results obtained when determining the crest factor (which is defined in general as the ratio of the peak value to the RMS or average value) necessitate better understanding of the signal processing

performed by a transmitter and the relevant measurement methods. Once we are equipped with suitable background, we can understand the reasoning behind the different approaches.

The content of this Application Note is divided into two parts. Part 1 (Chapter 2) deals with the determination of the crest factor and its consequences for the dimensioning of transmitter components. Part 2 (Chapter 3) provides additional background material for readers who want to go further. Based on the example of a DVB-T signal in 2K mode, we then take a precise look at OFDM signals ranging from generation to the modulated RF signal.

2 Determination and Usage of the Crest Factor

The crest factor of a modulated RF signal

The crest factor CF of a signal is computed, for example, from the ratio of the peak voltage \hat{U} to the RMS value U . For a sinusoidal signal, we obtain a crest factor CF of $\sqrt{2}$ or 3.01 dB using the familiar ratio \hat{U}/U of $\sqrt{2}$.

For information transmission using (wireless) telecommunications systems, a sinusoidal signal (carrier) is modulated by a baseband signal that contains the desired information. If the modulation causes a change in the amplitude of the carrier, the crest factor increases as well. The variation vs. time of this carrier amplitude is known as the "envelope" for modulated signals.

For a modulated RF signal, we can determine two different crest factors that differ by 3.01 dB depending on the approach we use:

The first possibility involves determining the crest factor based on the highest amplitude peak that occurs in the modulated carrier signal and the RMS value. We will refer to this as the "carrier approach" from now on since it takes the RF carrier into account in addition to the envelope. This is important when dimensioning transmitter components since the highest occurring peak voltage is critical when it comes to determining the dielectric strength.

The second way of determining the crest factor involves taking the ratio of the peak value of the modulation envelope to its RMS value. We will call this the "envelope approach" from now on. It is also analogous to the consideration of the baseband signal. The crest factor determined in this manner produces a result that is lower by the magnitude of the crest factor for the sinusoidal carrier (i.e. 3.01 dB) compared to the carrier approach. This approach is important when we are considering the operation of an amplifier in the RF range or a D/A converter in the baseband, for example.

Specification of the crest factor alone does not mean anything. We must also always indicate the approach we are using or the computation method.

Analogous to the ratio of the peak voltage to the RMS voltage, the crest factor in dB can also be expressed as the ratio of the peak power P_{PEP} to the average power P_{AVG} . With the linear approach, the crest factor resulting from the power ratio corresponds to the square value of the crest factor resulting from the voltage ratio. When indicated in dB, however, the two values are identical. For this reason, we will no longer make a distinction between the voltage ratio and the power ratio.

Determination and Usage of the Crest Factor

Technical references also use the term PAR (*peak-to-average power ratio*). When specified in dB, the PAR value corresponds to the crest factor obtained by means of the carrier approach. A sinewave carrier thus has a PAR value of 3.01 dB. When we are dealing with modulated RF signals we generally understand the term "peak power" to imply the value of the peak envelope power (P_{PEP}), the crest factor, as the ratio of the peak value to the average value, should be determined exclusively using the envelope approach.

The average power of a periodic signal is determined by squaring the voltage trace $u_{RF}(t)$ and then dividing it by the reference impedance. The value averaged over one period yields the average power of the signal. This is illustrated in Fig. 1 using the example of a pure continuous wave (CW) signal. On the left, we see the CW signal (blue) with the constant envelope (green). On the right, we see the squared trace (blue) that is referenced to 50 Ω and the average power (red) that is constant for a CW signal.

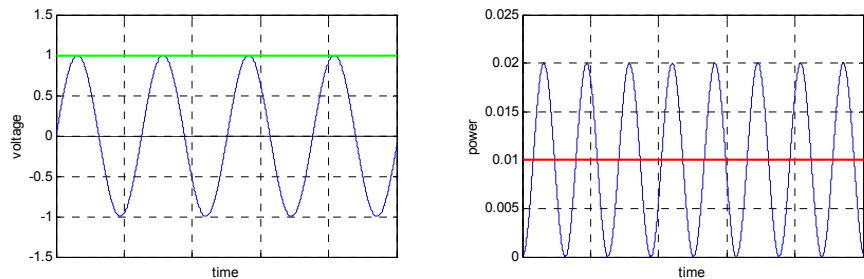

Fig. 1: Voltage and power of a CW signal into a 50 Ω load

The power is determined in the same manner for a modulated signal. This is illustrated in Fig. 2 using the example of an RF signal with amplitude modulation and a modulation depth $m = 0.5$. On the left, we see the voltage trace $u_{RF}(t)$ with a sinusoidal envelope. In the center, we see the squared time-domain signal that is referenced to 50 Ω (blue). The power trace that is averaged over one period is shown in the center and right in red. It corresponds to the trace of the envelope power. The peak envelope power (P_{PEP}) corresponds to the maximum value and is shown in green on the right. Also shown on the right (blue) is the average power P_{AVG} that has been averaged over a long interval.

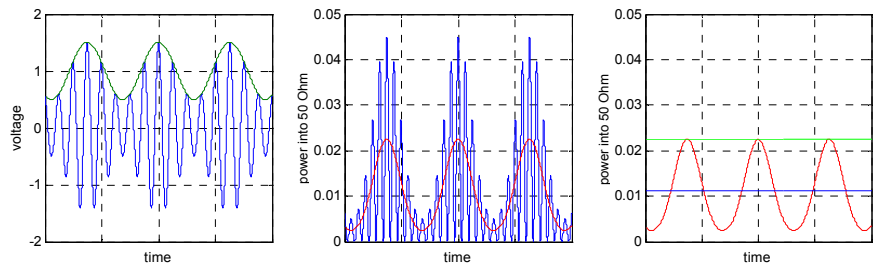

Fig. 2: Voltage and power of a modulated RF signal into a 50 Ω load

The peak envelope power P_{PEP} is the average power that the transmitter outputs during one period of the RF signal at the maximum value of the envelope. This is also the value that is displayed by peak power meters. For a signal with a constant envelope, the peak envelope power is equal to the average power. The crest factor is thus equal to 1 which corresponds to 0 dB.

Example: *The crest factor of a transmit signal is specified as 10 dB (P_{PEP}/P_{AVG}). Since the value is indicated for P_{PEP}/P_{AVG} , it is clear that the envelope approach is being used. The equivalent crest factor would then be equal to 13 dB with the carrier approach.*

Crest factor for multiple superimposed signals

If we switch several different transmit signals to an antenna, the individual signals will add up vectorially. This results in an increase in the crest factor. The same is true for an OFDM signal that consists of the superimposition of a number of individual carriers that are modulated.

When several nonharmonic (i.e. uncorrelated) sinusoidal signals are superimposed, the amplitudes add up to produce a maximum total peak voltage \hat{U} :

$$\hat{U} = \hat{U}_1 + \hat{U}_2 + \dots + \hat{U}_n \quad n = \text{number of carriers} \quad (1)$$

Since the signals are uncorrelated with one another, the power levels of the individual sinusoidal signals are added up to compute the average value of the sum signal, i.e. the squares of the RMS values of the voltages are added:

$$U = \sqrt{U_1^2 + U_2^2 + \dots + U_n^2} \quad n = \text{number of carriers} \quad (2)$$

If two sinusoidal signals with the same amplitude are superimposed, the peak voltage will double, i.e. the RMS value of the voltage will only increase by a factor of $\sqrt{2}$. Thus, the crest factor \hat{U}/U will also increase by a factor of $\sqrt{2}$, i.e. by 3.01 dB. When using the carrier approach, the crest factor is thus equal to 3.01 dB + 3.01 dB = 6.02 dB. This superimposition corresponds to a two-tone signal. Unlike the case of a single sinusoidal signal, the envelope is no longer constant. With the envelope approach, the crest factor is thus less by the amount of 3.01 dB and is now equal to 3.01 dB (instead of 0 dB for a single sinusoidal signal). With the envelope approach as well, the crest factor increases by the amount of 3.01 dB.

The increase in the crest factor due to the superimposition of two signals is thus independent of the approach we are using. If the number of signals with the same amplitude is doubled, the crest factor increases by 3.01 dB.

For the crest factor of n unmodulated and uncorrelated carriers with the same amplitude in dB, the following applies with the envelope approach:

$$CF = 20 \cdot \log(\sqrt{n}) = 10 \cdot \log(n) \quad (3)$$

With the carrier approach, the following applies:

$$CF = 10 \cdot \log(n) + 3.01 \text{ dB} . \quad (4)$$

This correlation is valid also if the individual carriers are already modulated and have a crest factor CF_c . For the crest factor of n modulated and uncorrelated signals with the same amplitude in dB, the following applies regardless of the approach we choose:

$$CF = 10 \cdot \log(n) + CF_c \quad (5)$$

Example: *Computation of the theoretical crest factor of a DVB-T signal in 2K mode with QPSK using the carrier approach:*

In this case, the DVB-T signal contains 1705 superimposed individual carriers that are each QPSK-modulated. Since the keying is handled without filtering with QPSK modulation in DVB-T, no additional crest factor occurs compared to a sinusoidal carrier. The crest factor of an individual carrier that is QPSK-modulated is thus equal to the same value as a sinusoidal signal, i.e. 3.01 dB. Since the amplitudes of the individual carriers are the same, our computation can be performed using (4) or (5). A crest factor of 35.32 dB is obtained using the carrier approach.

Crest factor measurement

With periodic signals, it is possible to determine the crest factor by measuring the peak and average or RMS values of the voltage or power using, for example, a state-of-the-art power meter or oscilloscope. If the signal is measured for the duration of one period, it is possible to completely measure the peak value as well as the RMS value, assuming the test equipment has sufficient speed for this task.

This is not the case with signals with random modulation such as an OFDM or DVB-T signal. While the average value of a DVB-T transmitter can be determined precisely in only a few seconds using a thermal power meter, the magnitude of the peak value is highly dependent on the measurement time. With high crest factors, the signal peaks are rarer, so that it is necessary to specify the crest factor that was determined along with the measurement interval or the number of samples. The crest factor that is determined is representative in this case only for the specified measurement interval and does not allow us to draw any conclusions about the actual crest factor of the signal during the entire turn-on interval.

Some understanding of the statistical probability of occurrence of signal peaks is very useful here. Specification of the complementary cumulative distribution function (CCDF) offers a good starting point. This is the statistical probability of occurrence of signal peaks that are greater by a factor k in dB than the average value. Here too, it is important to distinguish between the carrier and envelope approaches.

When generating an OFDM signal, an amplitude distribution arises in the baseband for the I and Q signals that is approximately normal in statistical terms. In other words, the I and Q signals resemble white noise. Based on the magnitude of the complex time-domain signal $i(t) + jq(t)$, the envelope is formed during modulation onto an RF carrier. Here, the amplitudes will have a Rayleigh distribution as an approximation. The probability of occurrence of high signal peaks is significantly less with a Rayleigh distribution than with a normal distribution. However, if we use the carrier approach on

the OFDM-modulated RF signal to statistically evaluate the amplitudes, we will again obtain normal distribution due to the carrier oscillation.

Fig. 3 shows a comparison of the CCDF for white noise (normal distribution) and for a Rayleigh distribution which occurs for the envelope of an ideal DVB-T signal as an approximation.

The CCDF of a sinusoidal signal is also shown using the carrier approach. For a sinusoidal voltage, the peak value \hat{U} is greater than the RMS value U by a factor of $\sqrt{2}$, i.e. the sinusoidal signal has a crest factor \hat{U}/U of 3.01 dB. No higher signal values occur, i.e. their probability is 0.

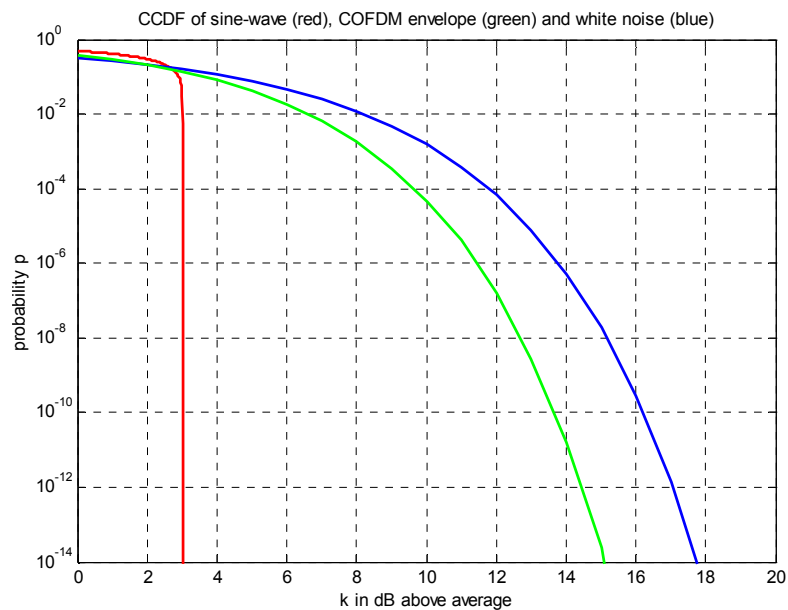

Fig. 3: CCDF for a sinusoidal signal (carrier approach), an OFDM envelope signal and for white noise

In actual practice, high crest factors of OFDM signals that exceed 12 dB using the envelope approach (or 15 dB with the carrier approach) are virtually impossible to measure even with very sophisticated test equipment.

Fig. 3 illustrates the problem: The probability of measuring signal levels that are only 1 dB higher is lower by a factor of about 60 when using the envelope approach. In other words, we need to multiply the measurement time by a factor of 60 to record signal peaks that are 13 dB above the average or RMS value. To record values at 14 dB, we need to multiply the measurement time by ten thousand. At 15 dB, we must multiply by seven million. Due to the signal duration of a power peak of approx. 110 ns for a DVB-T signal at 8 MHz, amplitude values that lie 12 dB over the average value on average occur once every second when using the envelope approach. At 15 dB, these peaks occur only once every 60 days. In other words, a signal peak that is 12 dB over the average or RMS value occurs on average for every 7.6 million samples during signal analysis.

If we are not aware of these concerns relating to the amplitude probability, it is easy to get the impression that a measured value is realistic since it appears stable even if the measurement interval is increased by a factor of

Determination and Usage of the Crest Factor

2 or even 10, for example. The measured value is then assumed (incorrectly under certain circumstances) to be the crest factor.

It is also important to ensure that the dynamic range of the test instrument is sufficient and that there is no converter or IF amplifier that limits the crest factor. In some test instruments, this dynamic range is indicated with the "margin" value. If an IF bandwidth has been selected that is too narrow, or an IF filter that is too steep, this can also impair the results, for example.

Since, in practical applications, the OFDM signal is highly limited for an individual transmitter, measurements made in the range of seconds or minutes will generally be sufficiently accurate. Based on the CCDF, it is clear when the clipping begins to manifest itself. The amplitude probability decreases more and more compared to an ideal signal (see Fig. 4).

The black trace shows a noise signal and the blue trace a typical DVB-T signal at a transmitter output with the envelope approach as measured using the R&S[®]FSU spectrum analyzer. In this case, the noise signal represents the noise of the test instrument with the receiver input terminated.

Starting at approx. 7 dB, the transmitter clipping begins to kick in, increasing very quickly. Even when using a measurement that is significantly longer, the measured crest factor of 9.6 dB increases only slightly since the trace is already dropping off in a very steep fashion here. With the noise signal, a crest factor of 12.13 dB was determined based on the ten million samples (Fig. 4), which is very close to the theoretical value produced using statistical analysis.

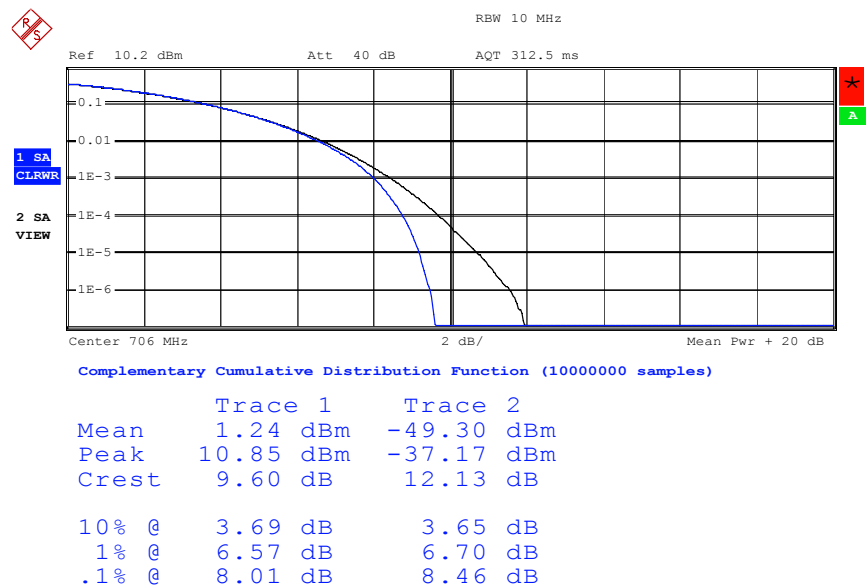

Fig. 4: CCDF for white noise and a DVB-T signal after a power amplifier (envelope approach) as measured by the R&S[®]FSU

Since the trace at 12 dB is still covered by the ideal trace from Fig. 3 and no clipping is detected, we can assume that the actual crest factor of this real noise signal is significantly higher. This measurement also shows that the dynamic range of the A/D converter is sufficient for the displayed range of the CCDF and does not yet have any impact on the measurement.

Test instruments such as the R&S®FSU or R&S®FSP spectrum analyzers or the R&S®EFA DVB-T test receiver from Rohde & Schwarz enable a crest factor measurement in which the CCDF is displayed simultaneously. Evaluation is based on the envelope approach or measuring in the baseband. With the R&S®EFA test receiver, the signal can also be evaluated using the carrier approach since the modulated signal is also sampled at the intermediate frequency (IF), which is equivalent to sampling the RF signal. It is possible to switch between the different measurement types using softkeys. The current setting is displayed on the right edge of the screen (see Fig. 9). The setting "CCDF(RF)" corresponds to the carrier approach and the setting "CCDF(ENV)" to the envelope approach. For more information about how these test instruments work, refer to [2] and [3].

Fig. 5 shows a modulated RF signal (blue) with its envelope (red) and the associated samples as measured by a test instrument. In case of direct sampling of the RF or IF signal, we obtain for a pure continuous wave (CW) signal a crest factor \hat{U}/U of 3.01 dB due to the sinusoidal function. Since the envelope is constant for a CW signal, a crest factor of 0 dB is displayed when sampling the envelope signal or measuring in the baseband. Besides the different amplitude distribution, there is also a difference of 3.01 dB when determining the crest factor depending on the measurement method.

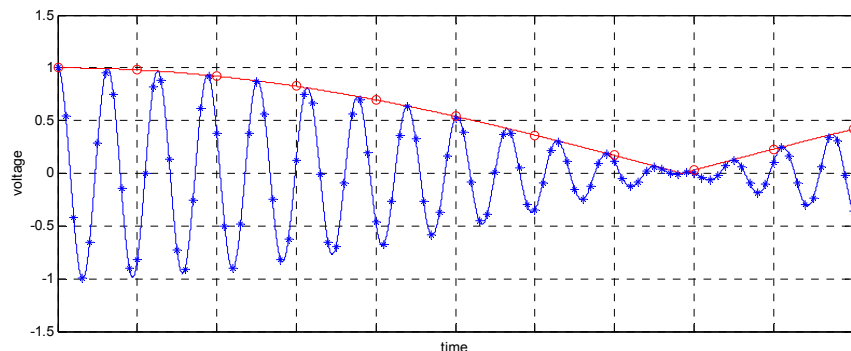

Fig. 5: Time-domain signal $u_{RF}(t)$ or $u_{IF}(t)$ with envelope and samples

Output signal from a DVB-T transmitter

As discussed above, the crest factor of the output signal from a DVB-T transmitter is significantly lower in actual practice than the theoretical value computed using (5). This limiting is due primarily to the D/A converter used for signal generation and the power amplifier.

In practical applications, the I and Q signals representing the DVB-T baseband signal are generated using a D/A converter that clips the signal through its conversion range and thus greatly reduces the crest factor. Depending on the quality criterion, the maximum output drive level is approx. 15 dB over the RMS value, which corresponds to a crest factor limiting to 15 dB. This limiting is performed in the digital signal processing at the numerical level in order to properly drive the D/A converter.

Since the baseband (magnitude from I and Q) is considered here prior to modulation, this represents the envelope approach. The 15 dB limiting has practically no effect yet on the signal quality since the signal peaks that are

Determination and Usage of the Crest Factor

clipped only occur extremely rarely (for the I and Q signal, the probability is approx. 2×10^{-8}).

Inside a transmitter, the greatest limiting of the DVB-T signal occurs in the power amplifier. The output stage is driven so that frequent signal peaks lie significantly above the 1 dB compression point.

Compression of the amplifier characteristic means that high signal peaks have less gain than the average value. This results in a lower amplitude probability for high signal peaks. The saturation power of the amplifier determines the maximum possible peak power and thus the crest factor.

Through precorrection of the baseband signal, high signal peaks have their level boosted to counteract the compression behavior of the amplifier. However, this does not affect the saturation power of the amplifier and thus the crest factor. The overall transfer characteristic up to the saturation power level is, however, linearized so that the amplitude probability for high signal peaks is increased.

A control circuit is used to maintain the average output power at a constant level. When precorrection is switched on, a test instrument will thus display a higher crest factor assuming the measurement interval remains the same (see Fig. 6).

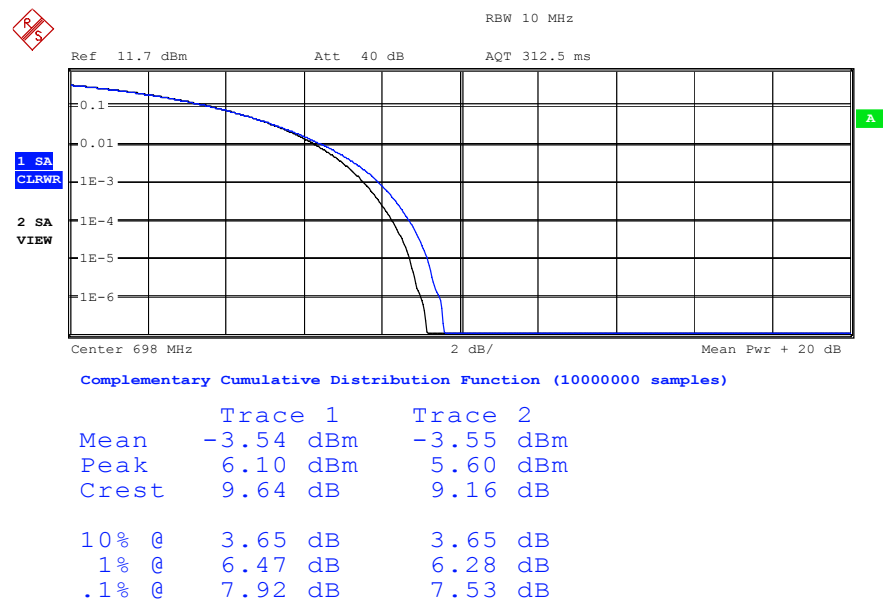

Fig. 6: CCDF at the transmitter output with and without precorrection (envelope approach)

However, a high crest factor does not represent a quality criterion for a transmitter. Intentional overdriving of the power amplifier is necessary to achieve high efficiency and thus economical operation. This overdrive manifests itself in the signal quality. Intermodulation products arise due to distortion in the nonlinear amplifier characteristic and appear in the form of shoulders above and below the useful spectrum on the spectrum analyzer.

Nevertheless, these intermodulation products also exist in the useful channel and can be displayed only through the use of special test instruments. In the constellation diagram, this limiting is seen in the form of small "signal

clouds". The signal vectors of the individual 64QAM-modulated carriers are no longer situated exactly in the center of the decision window.

Fig. 7 illustrates simulation of a hard clipped DVB-T signal (green trace) with the associated constellation diagram. The spectrum with the intermodulation products (shoulders) is shown in Fig. 8.

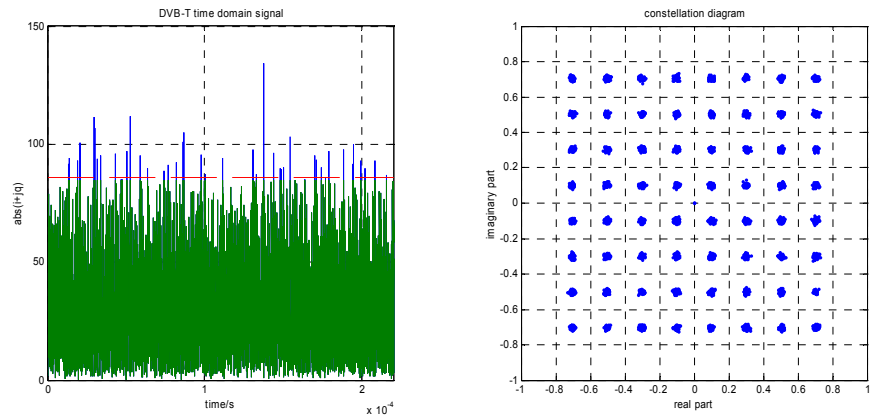

Fig. 7: Time-domain signal and constellation diagram for a clipped DVB-T signal

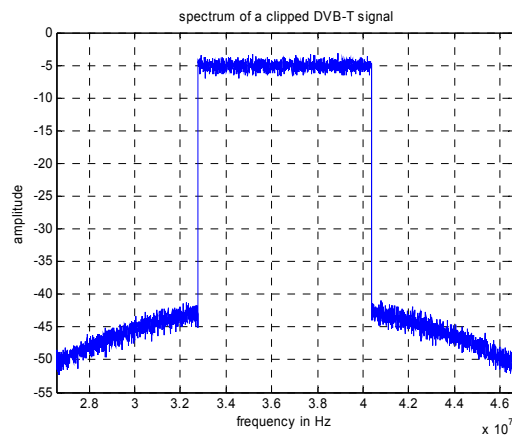

Fig. 8: Spectrum of the clipped DVB-T signal

Output bandpass

A bandpass filter is generally situated at the transmitter output. It largely eliminates any intermodulation products in the transmit signal outside of the useful frequency band that are caused by nonlinearities in the overdriven power amplifier. However, due to the very steep filter slopes, the envelope is deformed. As a result, the crest factor of the clipped signal again slightly increases.

Fig. 9 illustrates a measurement on the transmit signal before and after the bandpass filter using the R&S[®] EFA DVB-T test receiver. The transmit signal prior to the bandpass is shown on the left and the signal after the band-

pass is shown on the right using the carrier approach. This increase in the crest factor is dependent on the prior limiting and the filter slope. An unclipped signal does not produce any increase in the crest factor even after the bandpass filter, while this effect is particularly pronounced with highly clipped signals. Measurements and simulations have shown that the bandpass filter typically increases the crest factor of a DVB-T transmitter by 0.5 dB to 1.5 dB.

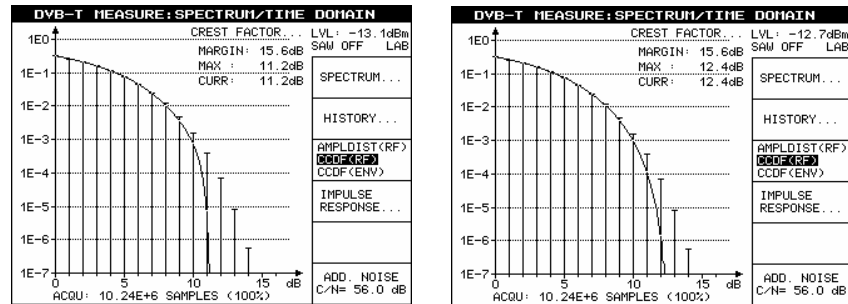

Fig. 9: Output signal of a DVB-T transmitter before and after the bandpass filter (carrier approach)

Interconnection of multiple transmitters on an antenna

If we interconnect two independent transmitters with the same power level and same crest factor on a common antenna line, this may cause a doubling of the amplitudes (same phase, maximum magnitude). The peak power is now four times higher than it was with a single transmitter. At the same time, the average power is doubled, so that each time we double the number of transmitters, the crest factor increases by 3.01 dB. Here too, we use (5) to determine the total crest factor for n transmitters that each have the same crest factor CF_c .

In transmitter systems with multiple transmitters, this sort of interconnection can result in very high values that exceed 20 dB (P_{PEP}/P_{AVG}) since, unlike with a single transmitter, there are generally no additional modules present that will limit the crest factor.

Besides the increase in the crest factor, the amplitude distribution also changes, as is revealed by a glance at the CCDF. Fig. 10 illustrates the simulation of a hard clipped DVB-T signal using the carrier approach along with superimposition of two and three similar transmit signals. By way of comparison, the CCDF for white noise is also shown. When multiple limited transmitters are superimposed, the overall signal starts to look more and more like white noise.

Determination and Usage of the Crest Factor

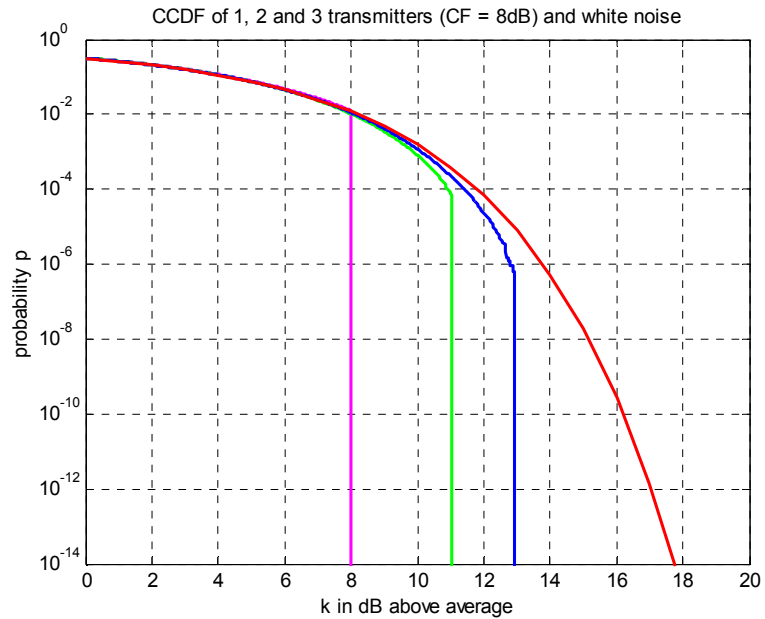

Fig. 10: From left to right: CCDF for one, two and three transmitters with CF = 8 dB and also for white noise (carrier approach)

Due to the output drive characteristic of the power amplifier, the clipping begins less abruptly in practical applications, but otherwise the behavior is basically the same. The drop in the amplitude probability is shifted to the right in the diagram by the increase in the crest factor.

Fig. 11 illustrates on the left a measurement of a real DVB-T signal that is operated well into the amplifier's clipping using the carrier approach. On the right, we see the superimposition of two similar transmitters that have different modulation. Here too, the amplitude distribution of the sum signal approaches white noise.

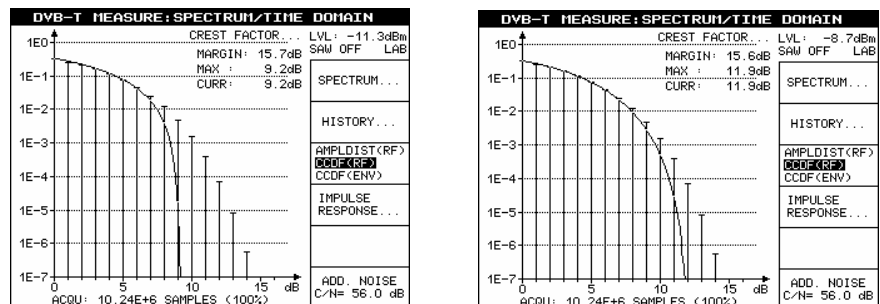

Fig. 11: CCDF for an individual transmitter and for two interconnected transmitters (carrier approach)

As the number of transmitters that are interconnected on an antenna line increases, it becomes more and more difficult to measure the crest factor of the sum signal. If we assume that we have a typical crest factor of 10 dB

Determination and Usage of the Crest Factor

(P_{PEP}/P_{AVG}) in an individual transmitter, the crest factor will already reach a value of 13 dB with two transmitters. With a greater number of transmitters, measurement becomes virtually impossible because signal peaks occur so rarely.

Another problem is the measurement bandwidth that is required since the transmitters can be distributed across a wide frequency range. Instead of a measurement, it is more practical in this case to determine the crest factor of the sum signal based on the measured values for the individual transmitters. When computing the amplitude probability, we can use the Rayleigh distribution or the normal distribution to suit our approach. In case of amplitude values up to approx. 3 dB below the peak value, there is hardly any deviation from the theoretical values provided by the two distribution functions. Above this, the probability decreases (see Fig. 11).

| k in dB | CCDF for normal distribution | CCDF for Rayleigh distribution | Average occurrence of modulation peaks based on a 109.375 ns signal duration (Rayleigh distribution) |
|----------------|-------------------------------------|---------------------------------------|---|
| 0 | 3.173×10^{-1} | 3.679×10^{-1} | 300 ns |
| 1 | 2.618×10^{-1} | 2.840×10^{-1} | 385 ns |
| 2 | 2.080×10^{-1} | 2.049×10^{-1} | 533 ns |
| 3 | 1.577×10^{-1} | 1.358×10^{-1} | 805 ns |
| 4 | 1.130×10^{-1} | 8.109×10^{-2} | 1.4 us |
| 5 | 7.540×10^{-2} | 4.237×10^{-2} | 2.6 us |
| 6 | 4.604×10^{-2} | 1.869×10^{-2} | 5.6 us |
| 7 | 2.516×10^{-2} | 6.650×10^{-3} | 16 us |
| 8 | 1.200×10^{-2} | 1.818×10^{-3} | 60 us |
| 9 | 4.832×10^{-3} | 3.558×10^{-4} | 0.3 ms |
| 10 | 1.567×10^{-3} | 4.548×10^{-5} | 2.4 ms |
| 11 | 3.882×10^{-4} | 3.412×10^{-6} | 32 ms |
| 12 | 6.863×10^{-5} | 1.310×10^{-7} | 0.83 s |
| 13 | 7.932×10^{-6} | 2.158×10^{-9} | 51 s |
| 14 | 5.387×10^{-7} | 1.232×10^{-11} | 2.5 hours |
| 15 | 1.877×10^{-8} | 1.855×10^{-14} | 68 days |
| 16 | 2.790×10^{-10} | 5.106×10^{-18} | 679 years |
| 17 | 1.452×10^{-12} | 1.724×10^{-22} | 20 million years |
| 18 | 1.973×10^{-15} | 3.979×10^{-28} | 8.7×10^{12} years |
| 19 | 4.967×10^{-19} | 3.155×10^{-35} | 1.1×10^{20} years |
| 20 | 1.524×10^{-23} | 3.720×10^{-44} | 9.3×10^{28} years |

Table 1: CCDF for signals with normal distribution and Rayleigh distribution

The higher the crest factor, the more the electric strength plays a role (in addition to the thermal capacity) if we want to properly dimension antenna combiners, RF lines and antennas to prevent flashover. What is critical here is the crest factor when using the carrier approach since it can be used to compute the maximum voltage amplitude.

Determination and Usage of the Crest Factor

We would also like to know how often we should expect a high signal peak. With DVB-T (carrier approach), the amplitudes of the modulated RF signal are normally distributed in approximation. An individual high peak in the envelope signal contains many oscillations of the carrier frequency since it lies well above the symbol clock rate of the DVB-T signal (roughly 70 RF oscillations at 650 MHz).

However, we are not interested in the many overshoots that occur during a DVB-T peak but rather in the frequency with which the modulation peaks occur. This can be determined using the Rayleigh distribution. Based on the shortest signal duration of 109.375 ns for a DVB-T signal with an 8 MHz bandwidth, we obtain the average time duration that elapses for an ideal signal until the average value is exceeded by a factor k (see Table 1).

Fig. 12 shows a peak of the modulated RF signal as occurs typically with DVB-T.

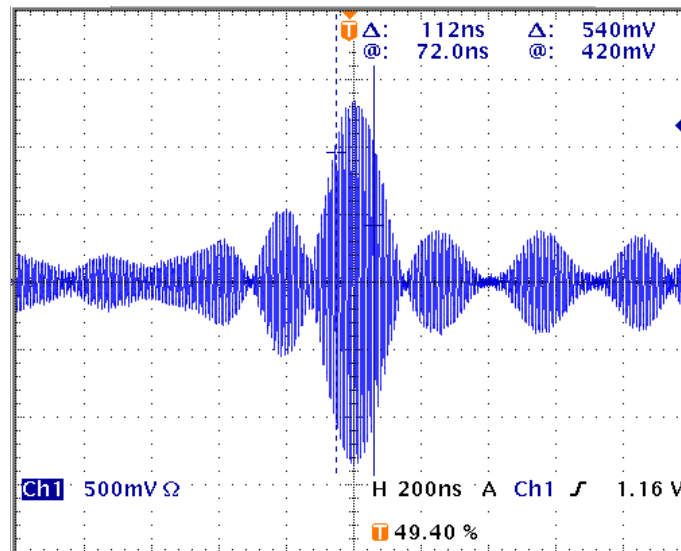

Fig. 12: Modulation peak in a DVB-T signal

Example: We want to connect five DVB-T transmitters to an antenna via a combiner. The crest factor of the individual transmitters is determined to have a value after the bandpass filter of 11 dB (P_{PEP}/P_{AVG}) while the average (thermal) transmit power is equal to 1 kW per transmitter.

Using (5), we obtain a crest factor of 18 dB with the envelope approach, or 21 dB with the carrier approach. The average power is equal to five times the value for a single transmitter, i.e. 5 kW. Based on the correlation $U = \sqrt{P \cdot R}$, we obtain an RMS RF voltage of 500 V at the 50 Ω antenna.

The maximum RF amplitude at the highest modulation peaks is 21 dB higher than the RMS value and is equal to 5.610 V. This corresponds to a maximum peak power $P_{PEP} = 315$ kW. From Table 1, we can now read off the amplitude probability for this maximum peak. It is equal to approx. $4 \cdot 10^{-28}$; it occurs

Determination and Usage of the Crest Factor

on average for an ideal signal only every $8.7 \cdot 10^{12}$ years. In practical applications, this already negligible probability is even lower since the clipping of the amplifiers kicks in at lower levels.

Starting at approx. 3 dB below the maximum power peak, we can assume that the amplitude probability already agrees with the theoretical value for a Rayleigh distribution. Power peaks that are 15 dB over the average value when using the envelope approach occur every 68 days on average. This corresponds to an RF amplitude of approx. 4000 V. Amplitude values that occur in the range of seconds are at ≥ 3000 V.

If we want to increase the number of transmitters to ten, the maximum peak voltage will double to a value of 11200 V. For modulation peaks that occur every 68 days on average, the RF amplitude exceeds a threshold of 5610 V. If we double the number of transmitters and compare the RF amplitude for the same average time intervals or the same amplitude probability, we obtain a value for the threshold that is higher only by a factor of $\sqrt{2}$ in contrast to the doubling for the theoretical peak value. This also corresponds to the increase in average power.

The peak voltage values calculated above are referenced to an ideally matched 50Ω system. When dimensioning the power components, we also must bear in mind the maximum increase in peak voltage due to a possible mismatch of the system.

Starting with crest factors of approx. 15 dB to 17 dB using the envelope approach, the amplitude probability is so low that it can be assumed to be constant when computing the electric strength. Transmitter systems consisting of about five or more transmitters are therefore likely to exhibit a constant crest factor of 15 dB to 17 dB (P_{PEP}/P_{AVG}). Depending on the planned safety margin, the actual value can be determined using Table 1. When adding additional transmitters, we then only need to take into account the increase in average power for an identical crest factor.

3 The Crest Factor During Generation of a DVB-T Signal

Part 2 of this Application Note describes the path of a signal produced by a DVB-T transmitter from modulation in the baseband to the RF signal. It also discusses the related consequences for the crest factor and the amplitude distribution.

Signal generation in the baseband

We will now describe by way of example how a DVB-T signal is generated with an 8 MHz bandwidth in 2K mode using 64QAM. First, we will consider some brief definitions relating to the DVB-T signal [4]:

In 2K mode, out of the theoretically available 2048 carriers, only 1705 carriers are used. The symbol clock rate is set to 64/7 MHz. If we divide the theoretical number of carriers (2048) by the symbol clock rate, we obtain a symbol duration of 0.224 ms.

The frequency spacing of the 1705 carriers is chosen so that the carriers lie in the zero points of the $\sin(x)/x$ modulation spectrum of the other carriers (orthogonality). The frequency spacing is computed from the reciprocal of the symbol duration and is equal to 4.464 kHz. Accordingly, we obtain a value for the bandwidth of the OFDM signal of 7.607 MHz (= [carrier number - 1] / symbol duration).

Each of the 1705 carriers is individually modulated using 64QAM and can assume 64 defined states. In a Cartesian coordinate system with I (= real part) and Q (= imaginary part) as the coordinate axes, we obtain a constellation diagram with 64 possible states for the signal vector (see Fig. 13).

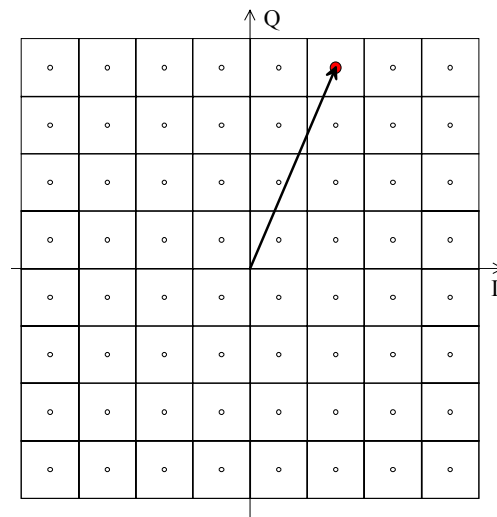

Fig. 13: Constellation diagram

The state of a carrier for a time period is generally referred to as a symbol. A DVB-T symbol corresponds to the overall status of all of the 1705 carriers. The symbol duration T_u is the period duration during which this state is retained until the next symbol follows. This state is extended by the duration of the guard interval, but we will ignore this fact in our discussion.

The 64 possible states for each carrier are determined by the coder that is connected ahead so that, in statistical terms, a seemingly random distribution is produced. "Seemingly" is an important word here since requested information is being transmitted. When observed over a long time interval, all 64 states of a carrier occur equally often, i.e. none of the states is more likely.

If one or more consecutive DVB-T symbols are transformed into the time domain using an inverse fast Fourier transform (IFFT), we obtain a complex signal whose real (I) and imaginary (Q) parts contain positive and negative values to an equal extent (see Fig. 14).

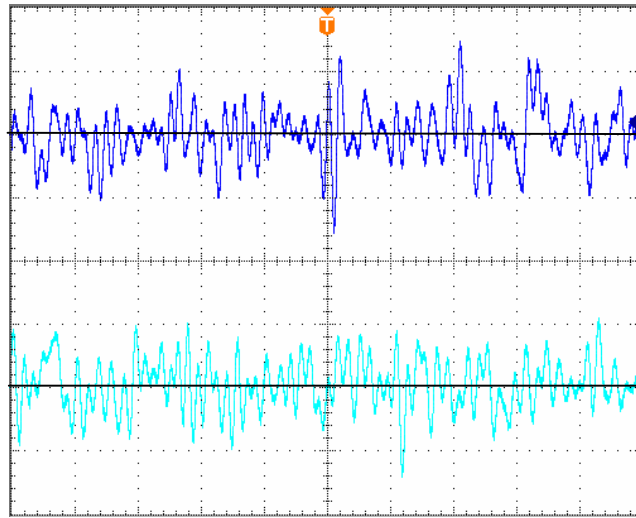

Fig. 14: I and Q signals in the time domain

Using the IFFT, we obtain a time-domain signal for I and for Q that is virtually equivalent to band-limited white noise.

The bandwidth of the baseband signal is equal to 3.803 MHz. This corresponds to half the modulation bandwidth of the RF signal. Using the reciprocal of the symbol clock rate of the DVB-T signal, we can compute the shortest duration of the signal peaks within this time-domain signal. Theoretically, it is equal to 109.375 ns, but the signal peaks are very rounded. The real minimum duration is best read off from individual, highly prominent signal peaks.

The average values of the two time-domain signals $u_i(t)$ and $u_q(t)$ are computed from the square mean values and both have the same magnitude. The signal is first squared, then averaged. From this result, we extract the root to again obtain a linear quantity.

$$U_{RMS_{i,q}} = \sqrt{\frac{1}{T} \cdot \int_0^T (u_{i,q}(t))^2 dt} \quad (6)$$

The amplitude frequency is greatest around the zero line and it decreases for higher amplitude values (positive and negative). The linear average is equal to 0 (see Fig. 14). This distribution of the amplitude vs. magnitude is known as the amplitude density distribution or more generally, the probability density function $p(u)$.

For white noise, the distribution of the amplitudes corresponds to a Gaussian or normal distribution (see Fig. 15). The standard deviation σ is the RMS value of the signal. This is also true in principle for the I and Q signals.

$$p(u) = \frac{1}{\sigma\sqrt{2\pi}} e^{-\frac{u^2}{2\sigma^2}} \quad (7)$$

The probability $p(u)$ of occurrence of a concrete amplitude value u is thus infinitely small. To be able to make an assessment, we multiply $p(u)$ by an interval Δu and thus obtain the probability that amplitude values will fall into this interval.

Since the crest factor for a signal that is normally distributed and has unlimited amplitude is infinitely large ($CF \rightarrow \infty$), we cannot attribute a value to it. On the other hand, the probability of occurrence of this crest factor tends toward zero ($P \rightarrow 0$). However, we are actually more interested in the following question: How probable is it that an amplitude (signal peak) will occur that is greater than the RMS value σ by a factor k ?

To determine this probability, we compute the following integral of the probability density function:

$$P_{i,q} = \frac{1}{\sigma\sqrt{2\pi}} \int_{k\cdot\sigma}^{\infty} e^{-\frac{u^2}{2\sigma^2}} \quad (8)$$

This is equal to the shaded area on the right in Fig. 15 (here: $k = 2$). Since negative amplitudes occur just as frequently as positive amplitudes, we only have to integrate one side of the bell trace. Numerical integration is required. Then, we multiply the result by 2. For the example where $k = 2$ in Fig. 15, we obtain the probability $P = 2 \cdot 0.0228$, i.e. 4.55%.

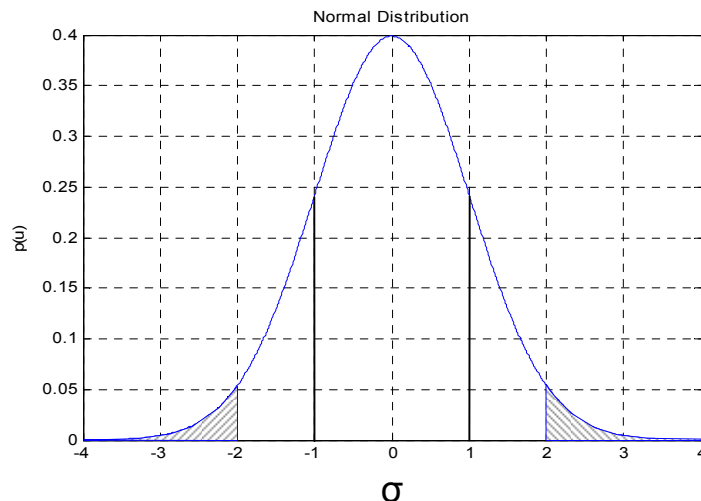

Fig. 15: Normal distribution

For the I and Q signals in the baseband, however, the crest factor is limited. In other words, we can specify a concrete value for the crest factor.

The highest theoretical peak value occurs if all 1705 carriers are driven with the maximum magnitude and the same phase. In this case, all of the voltage vectors add up to produce the maximum peak voltage. For the crest factor for 1705 carriers, we obtain a value of 32.32 dB (envelope approach).

The probability of occurrence of a signal peak that lies above this value is equal to 10^{-373} for white noise and is thus only relevant in theory. In the DVB-T signal, however, the carriers are modulated using QPSK, 16QAM or 64QAM depending on the mode. Since 16QAM or 64QAM modulation influences the envelope, each individual carrier already has a crest factor CF_c . On the other hand, the QPSK signal has a crest factor of 0 dB since the keying is performed in a hard fashion, i.e. without any filtering.

For a carrier that is modulated using 64QAM, the crest factor CF_c in the baseband is equal to approx. 3.7 dB. The highest possible voltage peak for I or Q after the IFFT in 2K mode is then 36 dB above this average value. The crest factor \hat{U}/U in the baseband is thus theoretically equal to 36 dB. In actual practice, this value is clipped by the subsequent D/A converter or the digital signal processing to approx. 15 dB.

Modulation of the carrier frequency

As part of the next signal processing step, the information from I and Q is modulated onto an RF carrier using an I/Q modulator (see Fig. 16) so that the signal can be broadcast. Before the modulator, there is a lowpass filter at each signal input to remove undesired signal processing products from the I or Q signal.

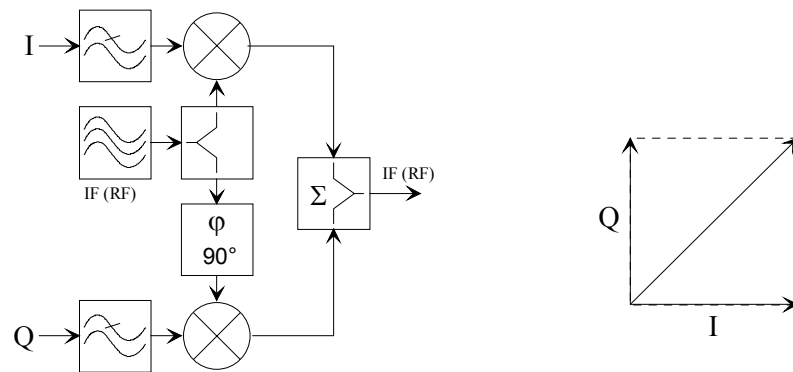

Fig. 16: I/Q modulator

As part of the modulation, the I component is multiplied (mixed) directly with a carrier signal and the Q component is multiplied (mixed) with a carrier signal with a 90° phase shift. Next, both signals are added together.

Depending on the transmitter system, the signal is modulated either directly or via a detour via an intermediate frequency (IF) to the final transmit frequency. The actual carrier frequency is suppressed. The amplitude of the RF oscillation corresponds to the magnitude of the complex signal consisting of the real (I) and imaginary (Q) parts (see Fig. 16 on the right):

$$u_e(t) = \sqrt{u_i(t)^2 + u_q(t)^2} \quad (9)$$

The magnitude determined from I and Q corresponds to the envelope of the modulated RF signal. The RMS value of this envelope signal is greater by a factor of $\sqrt{2}$ than that of I or Q.

The same applies to the peak voltage. The crest factor of the envelope signal is thus unchanged. However, the envelope signal now only has positive amplitude values so that the linear average is >0 . We obtain a different amplitude distribution than for the I and Q signals (see Fig. 17).

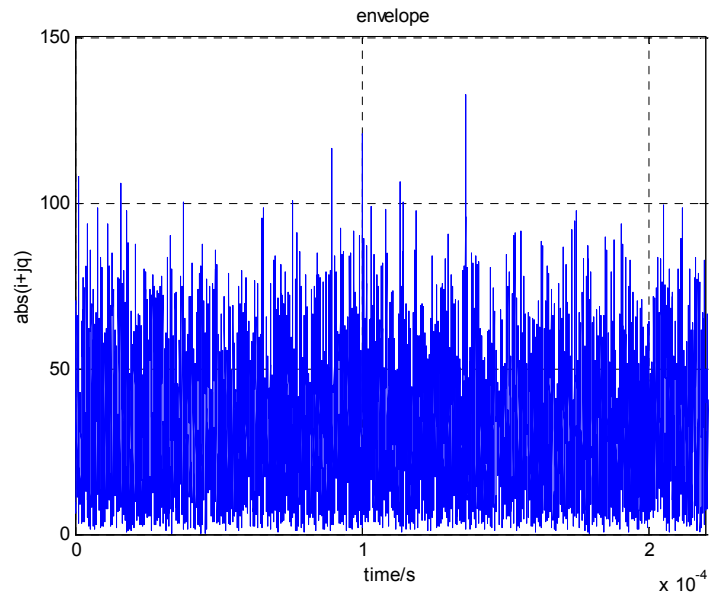

Fig. 17: Time-domain signal of the envelope

The probability density function is formed by a composite probability density [9] from two independent Gaussian distributions. This produces the Rayleigh distribution $p(r)$:

$$p(r) = \frac{r}{\sigma^2} \cdot e^{-\frac{u_r^2}{2\sigma^2}} \quad \text{where } u_r^2 = u_i^2 + u_q^2 \quad (10)$$

Fig. 18 shows the function trace of a Rayleigh distribution.

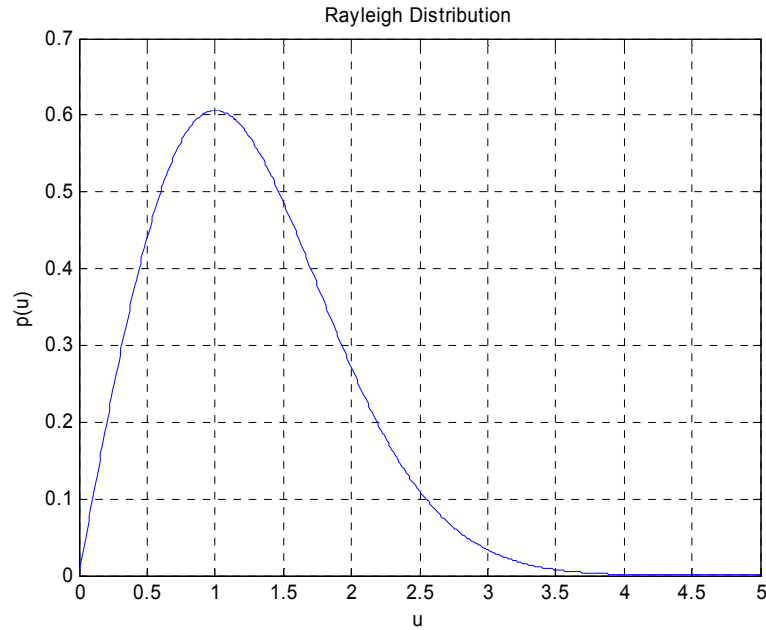

Fig. 18: Rayleigh distribution

To compute the probability of signal peaks that are greater than the RMS value by a factor k , we again take the integral of the probability density function:

$$P_r = \frac{1}{\sigma\sqrt{2\pi}} \int_{k\cdot\sigma\cdot\sqrt{2}}^{\infty} e^{-\frac{u_r^2}{2\sigma^2}} \quad (11)$$

Since the RMS value of the envelope signal is greater by a factor of $\sqrt{2}$ than with I or Q, the RMS value is equal to $\sigma\cdot\sqrt{2}$ for the Rayleigh distribution. It is clear that for the envelope signal the probability of exceeding a certain factor $k\cdot\sigma\cdot\sqrt{2}$ is significantly less than for white noise although the crest factor of the clipped signal has remained the same in absolute terms.

If we consider the time-domain signal $u_{RF}(t)$ of the modulated RF signal (see Fig. 5), we see that it has, like the I or Q signal, both positive and negative amplitude values. The linear average is equal to 0 and the amplitude distribution is a Gaussian distribution as before.

4 Summary

When specifying the crest factor for the modulated RF signal at the output of a DVB-T transmitter, we can choose between the envelope approach and the carrier approach.

Envelope approach

Since the transmitter outputs power, the specification of the crest factor is usually referenced to the ratio of the peak envelope power (P_{PEP}) to the average (thermal) power (P_{AVG}) of the transmitter. On the other hand, specification of the output voltage of a transmitter is not common. The average power P_{AVG} is the nominal output power and can be easily measured using thermal power sensors.

Measurement of the peak envelope power P_{PEP} is not always so simple. Peak power sensors that are capable of measuring short-lived and fairly rare power peaks to their full extent are difficult to find.

It is important to keep in mind that the peak envelope power P_{PEP} is also an average power that is emitted for the brief time interval of a modulation peak. For a pure CW signal for which the envelope is always constant, we thus obtain a crest factor of 0 dB. With the envelope approach, the peak value is referenced to the peak value of the modulation envelope and not the peak value of the RF carrier amplitude.

Since the envelope is formed from the magnitude signal of I and Q, the crest factor value P_{PEP}/P_{AVG} does not differ from the corresponding value in the baseband. Test instruments such as the R&S®FSU or R&S®FSP spectrum analyzers or the R&S®EFA DVB-T test receiver from Rohde & Schwarz allow a crest factor measurement in the baseband.

Besides the crest factor, these test instruments also display the distribution of the amplitudes in the form of a CCDF which provides more insight into the signal compared to a mere specification of the crest factor value.

However, measurement of high crest factors over 12 dB P_{PEP}/P_{AVG} is virtually impossible even with these instruments. This is due to the low probabilities of occurrence of signal peaks of this sort and the related long average time intervals between their occurrence.

The amplitudes of an ideal DVB-T signal have a Rayleigh distribution as an approximation when using the envelope approach.

Carrier approach

When determining the dielectric strength of RF components, however, we are interested in the peak voltage of the RF carrier. Accordingly, it makes sense to compute the crest factor from the ratio of the peak voltage of the RF signal to the RMS value. When using the carrier approach, we obtain (as for a sinusoidal signal) a value that is greater by 3.01 dB compared to the envelope approach.

The R&S®EFA DVB-T test receiver also allows measurement of the crest factor \hat{U}/U of the RF signal since the instrument also samples the IF signal (in addition to the baseband signal). The distribution of the amplitudes is also displayed in the form of a CCDF. When considering the RF signal, the amplitudes of an ideal DVB-T signal have an approximately normal distribution.

Specification of the crest factor

In view of the 3 dB difference for the crest factor and the different amplitude distributions produced by the envelope and carrier approaches, it does not make any sense to just specify the crest factor alone.

Such values are valid only in conjunction with an additional indication of the computation method or approach, e.g. P_{PEP}/P_{AVG} , "envelope approach", "carrier approach" or "measurement in the baseband". Since the signal peaks become increasingly rare as the values for the crest factor increase (i.e. the measurement result is highly dependent on the measurement time), it is very important to specify the measurement interval or the number of samples along with any measured value. In this respect, the CCDF offers a good overview of the probabilities of occurrence of signal peaks.

The crest factor in large transmitter systems

If multiple transmitters with different operating channels are connected to an antenna in a large system, the crest factor increases by 3.01 dB each time the number of transmitters is doubled. There is no further clipping of the power peaks such as in a power amplifier, and this fact needs to be taken into account when choosing the electric strength of the components that are used.

For very high crest factors, the probability of occurrence of power peaks is very low. Based on the Rayleigh distribution, it is possible to determine the average time interval between power peaks whose amplitudes lie above the average value by a factor k . The probability is a good match with the Rayleigh distribution up to about 3 dB below the maximum peak value. Beyond this value, it decreases compared to the theoretical values.

For crest factors starting at approx. 15 dB to 17 dB, the probability of power peaks is so low that we can neglect even higher values when using the envelope approach. This means that systems consisting of about five or more transmitters are likely to exhibit a constant crest factor of approx. 15 dB to 17 dB.

5 References

- [1] dB or not dB? Application Note [1MA98](#), Rohde & Schwarz, 7/2005
- [2] Christoph Balz, CCDF determination – a comparison of two measurement methods, News from Rohde & Schwarz, No. 172 (2001/III), pp 52 - 53
- [3] Sigmar Grunwald, Measurements on MPEG2 and DVB-T signals (4), News from Rohde & Schwarz, No. 172 (2001/III), pp 44 - 48
- [4] Seamus O’Leary, Understanding Digital Terrestrial Broadcasting, Artech House, 2000
- [5] Andrea Goldsmith, Wireless Communications, Cambridge University Press 2005, pp 393 – 394
- [6] Walter Fischer, Digital Television, A Practical Guide for Engineers, Springer-Verlag Berlin Heidelberg 2004
- [7] E. Schrüfer, Elektrische Messtechnik [*Electrical test equipment*], Carl Hanser Verlag Munich, 1990
- [8] Friedrich Landstorfer, Heinrich Graf, Rauschprobleme in der Nachrichtentechnik [*Noise problems in communications engineering*], 2nd edition 1991, Oldenbourgverlag Munich
- [9] Prof. Dr.-Ing. Dietmar Rudolph, Anwendungen der Fourier-Transformation, Teil 6, Skript zur Vorlesung Signale und Systeme [*Applications of the Fourier transform, Part 6, Transcript of lecture on signals and systems*], Berlin University of Applied Sciences

6 Additional information

We welcome your questions and comments about this Application Note. Please e-mail them to:

Broadcasting-Transmitters.rsd@rohde-schwarz.com.

Also visit the Rohde & Schwarz website at www.rohde-schwarz.com. The website contains additional Application Notes along with other useful information.



ROHDE & SCHWARZ GmbH & Co. KG · Mühldorfstraße 15 · D-81671 Munich · Postfach 80 14 69 · D-81614 Munich · Tel +49-(0) 89 4129 -0 · Fax +49-(0) 89 4129 - 13777 · Internet: <http://www.rohde-schwarz.com>

This application note and the supplied programs may only be used subject to the conditions of use set out in the download area of the Rohde & Schwarz website.