

Generating a Test Signal for Distributed DVB-T2 MISO

Application Note

Products:

R&S®BTC	R&S®SFU	R&S®ETL
	R&S®SFE	R&S®ETC
	R&S®SFE100	
	R&S®SFC	

This application note describes how the transmitter landscape of a DVB-T2 single-frequency network (SFN) can be simulated in multiple input single output (MISO) mode in order to test the compatibility and performance of receiver modules.

Neither an external T2-MI gateway nor a GPS receiver is required – just an R&S®BTC equipped with two RF paths.

Alternatively, one R&S®SFU coupled with one or more R&S®SFU, R&S®SFE, R&S®SFE100 or R&S®SFC can also be used.

R&S®ETL or R&S®ETC are suggested to fine-tune the synchronization between the generated RF signals.

Table of Contents

1	Introduction	3
1.1	Organization.....	3
1.2	Technical Background.....	3
2	Implementation.....	5
2.1	R&S® BTC Setup.....	5
2.1.1	Requirements.....	5
2.1.2	Test setup.....	5
2.1.3	Configuration	6
2.1.4	Synchronization.....	7
2.2	R&S® SFU based setup.....	8
2.2.1	Requirements.....	8
2.2.2	Required Firmware Versions.....	9
2.2.3	Test Setup	9
2.2.4	Configuration	9
2.3	Synchronization.....	11
2.4	Modifications for Long-Term Testing.....	12
2.4.1	User-Defined T2-MI Stream Files	12
2.4.2	Live Signal from the T2-MI Gateway.....	12
3	Abbreviations	13
4	Literature.....	13
5	Additional Information	13
6	Ordering Information	14

1 Introduction

The new DVB-T2 terrestrial television standard is continuously gaining importance. New systems are being tested in many countries around the world, while others are already in the introductory phase. Such an advanced level of implementation means that the more complex innovations of the standard will find increasing usage in real systems. This includes, among others, the distributed MISO technology, which is used to reduce destructive interference in SFNs.

This application note describes how the transmitter landscape of a DVB-T2 SFN can be simulated in MISO mode in order to test the compatibility and performance of receiver modules. Neither an external T2 MI gateway nor a GPS receiver is required – just an R&S[®] BTC broadcast test center equipped with two RF paths.

Alternatively, one R&S[®] SFU broadcast test system coupled with one or more R&S[®] SFU, R&S[®] SFE, R&S[®] SFE100 or R&S[®] SFC can also be used.

R&S[®] ETL TV analyzer or R&S[®] ETC compact TV analyzer are suggested to fine-tune the synchronization between the generated RF signals.

Template: 3573.7380.02/CI 01.00

1.1 Organization

Section 1.2 describes the history behind distributed MISO technology in the DVB-T2 standard. Chapter 2 describes its implementation, starting with the basic architecture for rapid signal generation. This is followed by a description of the modifications needed to generate signals for long-term testing, as well.

1.2 Technical Background

In traditional SISO SFNs, all participating sites transmit signals synchronously in terms of frequency, content, and time. At the receiver, this results in an overlay of more-or-less identical signals that differ only in power and delay difference. However, this can lead to significant destructive spectral interference, especially when the power differences are small:

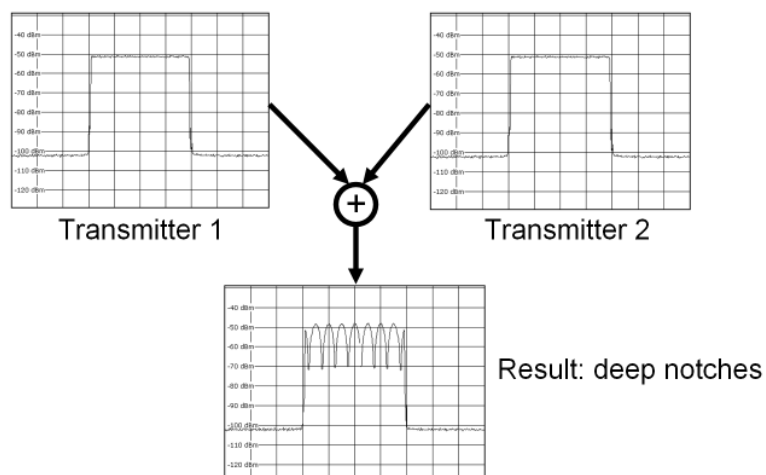

Fig. 1: Destructive interference when receiving two signals in a SFN without MISO [1].

To prevent this interference, the DVB-T2 standard [2] provides MISO technology using a modified Alamouti matrix:

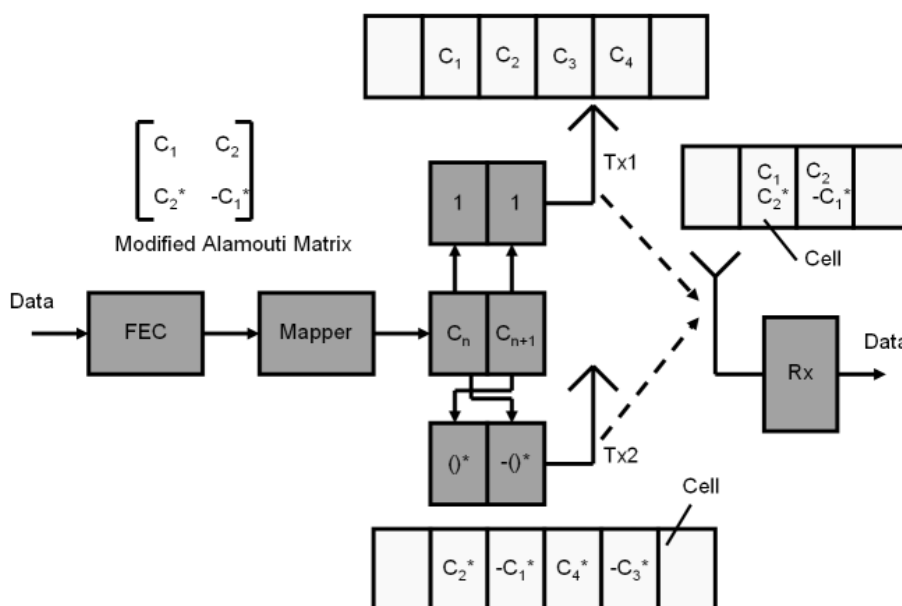

Fig. 2: The modified MISO Alamouti matrix provided by DVB-T2 [1].

In addition to the regular transmit signal for Tx1 (MISO group 1), a second, spectrally uncorrelated signal is sent by Tx2 (MISO group 2) in which the symbols (cells) of adjacent carriers are swapped but then later reconstructed. If these differing signals are then output by adjacent transmitters in a SFN (distributed MISO), they are overlaid in the receiver without causing spectral interference:

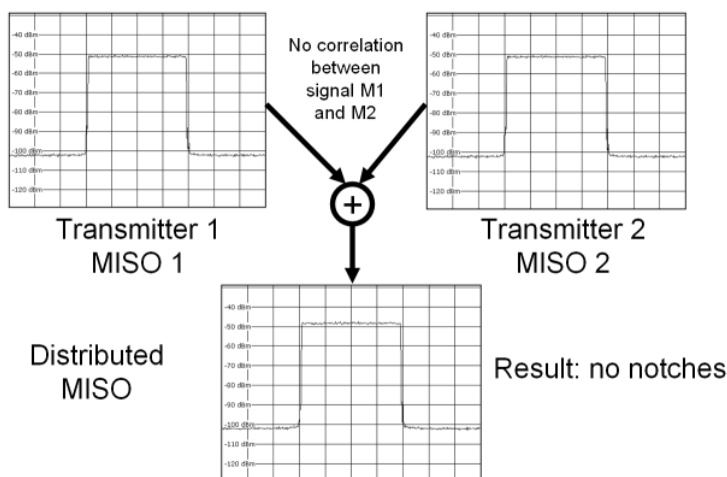

Fig. 3: No interference when receiving two signals in a SFN with MISO [1].

2 Implementation

The R&S®BTC broadcast test center with two RF paths in a single box allows the simulation of two transmitters with independent MISO groups. This setup is described in subchapter 2.1.

Alternatively, one R&S®SFU broadcast test system coupled with one or more R&S®SFU, R&S®SFE broadcast tester, R&S®SFE100 test transmitter or R&S®SFC compact modulator can also be used. This setup is described in subchapter 2.2.

Subchapter 2.3 then explains how to fine-tune the synchronization between the generated RF signals with either R&S®ETL TV analyzer or R&S®ETC compact TV analyzer.

Finally, subchapter 2.4 describes how to extend the test setups for long term testing.

2.1 R&S®BTC Setup

2.1.1 Requirements

- 1 x R&S®BTC (firmware version ≥ 1.50)
each of the two RF paths equipped with DVB-T2 coder (R&S®BTC-K516)
- 1 x T2-MI MISO stream as a file, including relative time stamps for SFN synchronization (e.g. from R&S®LIB-K57, version ≥ 1.20)
- 2-path RF power combiner matching the desired frequency and power range (Resistive tee technology is not recommended, since its suboptimal isolation performance negatively affects signal quality. Thus alternative concepts based on coupled transmission lines or transformers are preferred.)

2.1.2 Test Setup

2.1.2.1 Rear side

Connect TS SERIAL OUT of baseband generator module 1 (left side) to TS SERIAL IN of baseband generator module 2 (right side).



Fig. 4: R&S®BTC rear side setup.

2.1.2.2 Front side

Connect the 2-path power combiner to RF path output 1 and 2 to get the MISO single output sum signal.



Fig. 5: R&S®BTC front side setup.

2.1.3 Configuration

2.1.3.1 Settings for both RF paths

- Select the appropriate output power.
- Activate the DVB-T2 coder with the same frequency, channel bandwidth and T2-MI input stream PID.
- In "TX:SignalGen:Input Signal", set "T2-MI Interface" to "On".
- In "TX:SignalGen:T2 System", set "Network Mode" to "SFN" and select the appropriate "MISO Group" (1 or 2).
Assigning the same MISO group to both RF paths will result in spectral notches caused by destructive interference, as described in chapter 1.2.

2.1.3.2 Specific settings for RF path A

- a) In “TX:SignalGen A:Input Signal”, set “Source” to “MM Generator”.
- b) In “MMGen:Player 1”, select the appropriate T2-MI MISO transport stream.
(e.g. t2mi_vv018_rs_gmit_gw_180sec.T2MI_C from the R&S®LIB-K57 library)
- c) Make sure the “MMGen:Player 1” output data rate matches the selected T2-MI file.
(This value is automatically set correctly when selecting a file from the R&S®LIB-K57 library.)

2.1.3.3 Specific settings for RF path B

- a) In “TX:SignalGen B:Input Signal”, set “Source” to “External”.
- b) In “TX:SignalGen B:Input Signal”, set “Input” to “TS IN 3”.
- c) In “TX:SignalGen B:SFN”, set “1PPS Routing” to “Internal Input”.

2.1.4 Synchronization

Fine-tune the synchronization between the generated RF signals with either R&S®ETL or R&S®ETC like described in subchapter 2.3.

2.2 R&S®SFU based Setup

2.2.1 Requirements

2.2.1.1 Master transmitter

- 1 x R&S®SFU with DVB-T2 coder (R&S®SFU-B15 and R&S®SFU-K16) and TRP player (R&S®SFU-K22)
- 1 x T2-MI MISO stream as a file, including relative time stamps for SFN synchronization (e.g. R&S®SFU-K227, version ≥ 1.30)
- 1 x adapter cable DA-15 (male) to BNC (male):



Fig. 6: The required adapter cable connects the DA-15 pin (blue) with the BNC inner contact and the other pin (grey) with the outer contact

2.2.1.2 Slave transmitters

For each additional transmitter in the SFN being simulated:

- R&S®SFC or R&S®SFE100 or R&S®SFE or R&S®SFU each with a DVB-T2 coder (R&S®SFx-B15 and R&S®SFx-K16)

2.2.1.3 Cabling

Corresponding to the number of transmitters:

- RF coupling network in the desired frequency and power range (Resistive tee technology is not recommended, since its suboptimal isolation performance negatively affects signal quality. Thus alternative concepts based on coupled transmission lines or transformers are preferred.)
-
- BNC distribution system for the following signals
 - 1 x TS-ASI (75 Ω , 800 mV)
 - 1 x 10 MHz reference frequency (50 Ω , 5 dBm)
 - 1 x 1 pps (50 Ω , 2 V)

2.2.2 Required Firmware Versions

R&S®SFU	R&S®SFE	R&S®SFE100	R&S®SFC
≥ 2.80	≥ 2.80	≥ 2.80	≥ 2.80

2.2.3 Test Setup

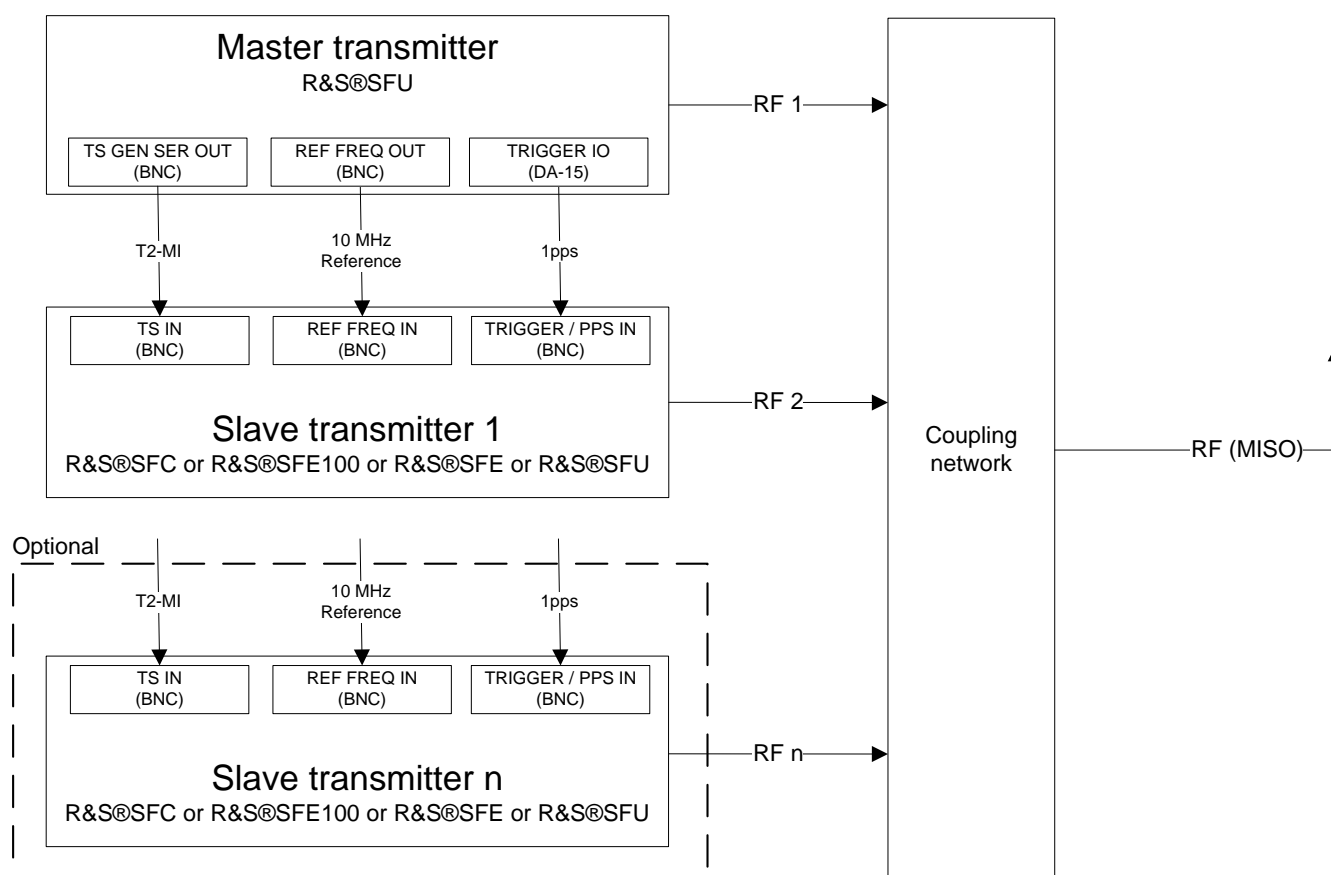

Fig. 7: Test setup

The R&S®SFU master transmitter is the central element of the architecture. By using the internal T2-MI generator, the R&S®SFU can provide the 10-MHz reference clock as well as the other synchronization signals required for the SFN (T2-MI & 1 pps), not only for itself but also for the slave transmitters. This eliminates the need for an external T2-MI gateway or an external GPS receiver.

2.2.4 Configuration

2.2.4.1 Settings for all transmitters

- Select the appropriate output power.
- Activate the DVB-T2 coder with the same frequency, channel bandwidth and T2-MI PID.

- c) In TX:DIGITAL TV:INPUT SIGNAL, set T2-MI INTERFACE to ON.
- d) In TX:DIGITAL TV:T2 SYSTEM, set NETWORK MODE to SFN and select the appropriate MISO GROUP (1 or 2).
Assigning the same MISO group to different transmitters will result in spectral notches caused by destructive interference, as described in chapter 1.2

2.2.4.2 Specific settings for the master transmitter

- a) Configure SETUP:HARDWARE SETTINGS:TRIGGER as follows:

TRIGGER IN			IN ▾
TRIGGER OUT			OUT ▾
TRIGGER I/O PIN			4
TRIGGER I/O STATE			OUT ▾
TRIGGER I/O SOURCE			SIGNAL SOURCE MARKER 2 ▾
	STATE	SOURCE / DESTINATION	
TRIGGER I/O 1	OUT	GND	
TRIGGER I/O 2	OUT	GND	
TRIGGER I/O 3	OFF	---	
TRIGGER I/O 4	OUT	SIGNAL SOURCE MARKER 2	

Fig. 8: Configuration of the 1 pps signal at the Trigger Out interface.

- b) In TX:DIGITAL TV:INPUT SIGNAL, set T2-MI SOURCE to INTERNAL.
- c) In TSGEN, select the appropriate T2-MI MISO transport stream.
(e.g. t2mi_vv018_rs_gmit_gw_180sec.T2MI_C from the R&S®SFU-K227 library)
- d) Make sure the TSGEN output data rate matches the selected T2MI file. (This value is automatically set correctly when selecting a file from the R&S®SFU-K227 library)

2.2.4.3 Specific settings for the slave transmitters

- a) In SETUP:HARDWARE SETTINGS:REFERENCE, set SOURCE to EXT.
- b) In TX:DIGITAL TV:INPUT SIGNAL, set T2-MI SOURCE to EXTERNAL.
- c) In TX:DIGITAL TV:INPUT SIGNAL, set T2-MI INPUT to match the cabling.

2.3 Synchronization

When the individual RF signals will be setup for the first time, they will initially not be synchronized because of the latency inherent to external cabling.

Synchronization can be achieved by analyzing the channel impulse response of the MISO sum signal at the output of the coupling network with either R&S®ETL TV analyzer or R&S®ETC compact TV analyzer.

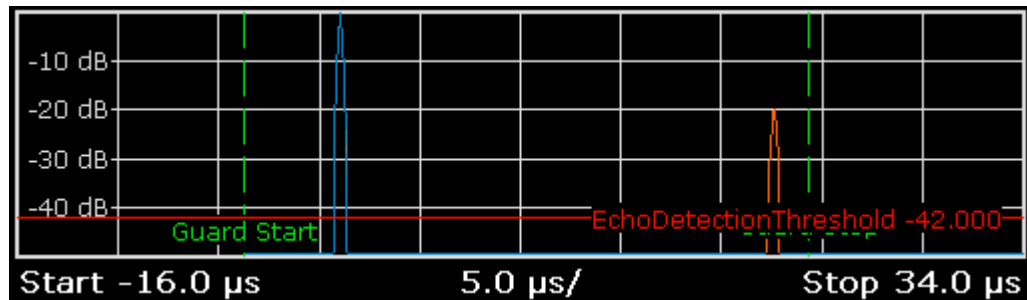

Fig. 9: This channel impulse response on the R&S®ETL TV analyzer shows two DVB-T2 transmitters with a time offset of 21.5 μ s (blue = MISO Group 1, orange = MISO group 2).

The leading RF signal can then be delayed as needed by adapting the “Static Delay” value appropriately in the DVB-T2 SFN settings:

PROCESS DELAY	9.6 us
STATIC DELAY	-21.5 us
DYNAMIC DELAY	647 002.1 us
TOTAL DELAY	646 990.2 us
MAX DEVIATION TIME	10.0 us
MUTE FIRST P1 OF SUPER FRAME	OFF
BACK	

Fig. 10: The **STATIC DELAY** parameter is used to synchronize the transmitters.



If the T2-MI data stream is changed in the transport stream generator, or if one of the coder settings is changed for any of the RF signals, the individual coders will, on rare occasions, lock in on the common T2-MI signal so differently that the delay becomes significantly greater than the length of the guard interval.

In this case, the **PROCESS DELAY** values (see Fig. 10) for the coders will differ by significantly more than several 10 μ s. This problem can be fixed by stopping and then restarting the T2-MI data stream in the transport stream generator.

2.4 Modifications for Long-Term Testing

The T2-MI streams in the recommended R&S[®]LIB-K57 / R&S[®]SFU-K227 library offer a runtime of 1 and 3 minutes. Even when the stream is cycled endlessly, the system causes the output signal to be interrupted when the stream loops back to the beginning of the file because the individual DVB-T2 coders must be resynchronized to the T2-MI stream. However, the time delay set between the RF signals remains in place.

There are two basic methods for preventing these periodic signal interruptions for long-term testing.

2.4.1 User-Defined T2-MI Stream Files

T2-MI streams with longer runtimes can be generated from the content files of the R&S[®]SFU-K227 library by using the integrated R&S[®]BCMUX software on the R&S[®]SFU.

Alternatively, the R&S[®]SFU TS/ETI recorder (R&S[®]SFU-K21) can be used to record longer T2-MI streams, for example at the output of a T2-MI gateway. These must include relative time stamps for the SFN synchronization if they are to be used later.

2.4.2 Live Signal from the T2-MI Gateway

2.4.2.1 BTC setup

Instead of feeding both DVB-T2 coders by the internal “MMGen:Player 1”, the T2-MI stream is provided externally from a T2-MI gateway using R&S[®]BTC front side “TS INPUT 1” or “TS INPUT 2”, which will distribute the signal to both coders.

This also requires using further signals from the T2-MI gateway:

- Connect its 10 MHz reference signal to the R&S[®]BTC “REF IN” input, and activate this interface by setting “Setup:Hardware Settings:External Reference Frequency:Source” to “External”.
- Connect its 1 pps signal to the R&S[®]BTC “EXT 1” input, and activate this interface by setting TX:SignalGen:SFN:1PPS Routing” to “External Input” for both RF paths.

2.4.2.2 SFU based setup

A separate R&S[®]SFU master transmitter is no longer required for an unlimited runtime. The T2-MI stream, 10 MHz reference signal and 1 pps signal are provided directly to all transmitters by a T2-MI gateway coupled with a GPS receiver.

3 Abbreviations

GPS	Global Positioning System
MISO	Multiple Input Single Output
PID	Packet Identifier
SFN	Single Frequency Network
SISO	Single Input, Single Output
T2-MI	DVB-T2 Modulator Interface

4 Literature

- [1] "Digital Video and Audio Broadcasting Technology",
Walter Fischer, 2010,
ISBN 978-3-642-11611-7
- [2] "Digital Video Broadcasting (DVB);
Frame structure channel coding and modulation for a second generation digital
terrestrial television broadcasting system (DVB-T2)",
ETSI EN 302 755, V1.2.1, 2011-02

5 Additional Information

Our Application Notes are regularly revised and updated. Check for any changes at <http://www.rohde-schwarz.com>.

Please send any comments and suggestions about this Application Note to Broadcasting-TM-Applications@rohde-schwarz.com.

6 Ordering Information

Designation	Type	Order No.
One box solution: R&S®BTC		
Broadcast Test Center	R&S®BTC	2114.3000.02
RF Path A	R&S®BTC-B3103	2114.3100.02
- 100 kHz to 3 GHz		
or		
- 100 kHz to 6 GHz	R&S®BTC-B3106	2114.3200.02
RF Path B	R&S®BTC-B3203	2114.3300.02
- 100 kHz to 3 GHz		
or		
- 100 kHz to 6 GHz	R&S®BTC-B3206	2114.3400.02
Baseband Main Module, two I/Q paths to RF	R&S®BTC-B12	2114.6600.02
Baseband Generator, 1st channel	R&S®BTC-B1	2114.3500.02
DVB-T2 Coder	R&S®BTC-K516	2114.7035
Baseband Generator, 2nd channel	R&S®BTC-B2	2114.3600.02
DVB-T2 Coder	R&S®BTC-K516	2114.7035
Recommended		
DVB-T2 MI Streams	R&S®LIB-K57	2116.9429.02
Alternative Master Transmitter: R&S®SFU		
Broadcast Test System	R&S®SFU	2110.2500.02
DVB-T2 Coder	R&S®SFU-K16	2110.7847.02
Coder Extension 15 (for digital TV)	R&S®SFU-B15	2110.7918.02
TRP Player	R&S®SFU-K22	2110.7499.02
Recommended		
DVB-T2 MI Streams	R&S®SFU-K227	2115.2120.02
TS/ETI Recorder ¹	R&S®SFU-K21	2110.7482.02
Alternative Slave Transmitter(s): R&S®SFU / R&S®SFE / R&S®SFE100		
Broadcast Test System	R&S®SFU	2110.2500.02
DVB-T2 Coder	R&S®SFU-K16	2110.7847.02
Coder Extension 15 (for digital TV)	R&S®SFU-B15	2110.7918.02
Broadcast Tester	R&S®SFE	2112.4300.02
DVB-T2 Coder	R&S®SFE-K16	2113.4290.02
Coder Extension Board	R&S®SFE-B15	2112.4200.02
Test Transmitter	R&S®SFE100	2112.4100.02
DVB-T2 Coder	R&S®SFE100-K16	2113.4284.02
Coder Extension Board	R&S®SFE100-B15	2112.4222.02

¹ For optional recording of T2-MI streams (see 2.4.1).

Designation	Type	Order No.
Alternative Slave Transmitter(s): R&S®SFC		
Compact Modulator	R&S®SFC	2115.3510.02
DVB-T2 Coder	R&S®SFC-K16	2115.5494.02
Coder Extension Board	R&S®SFC-B15	2115.5836.02
DVB-T2 TV Analyzer: R&S®ETL / R&S®ETC		
TV Analyzer, 500 kHz to 3 GHz, with tracking generator	R&S®ETL	2112.0004.13
DVB-T2 Firmware ²	R&S®ETL-K340	2112.0527.02
Compact TV Analyzer, up to 3.6 GHz Compact TV Analyzer, up to 8 GHz	R&S®ETC	2116.5000.04 2116.5000.08
FPGA Extension Board	R&S®ETC-B300	2116.5230.02
DVB-T2 Analysis	R&S®ETC-K240	2116.5123.02

² Requires R&S®ETL-B300 (2112.0385.02) or R&S®ETL-B310 (2112.0340.02). R&S®ETL-B310 requires R&S®ETL-B203 (2112.0327.03).

About Rohde & Schwarz

Rohde & Schwarz is an independent group of companies specializing in electronics. It is a leading supplier of solutions in the fields of test and measurement, broadcasting, radiomonitoring and radiolocation, as well as secure communications. Established more than 75 years ago, Rohde & Schwarz has a global presence and a dedicated service network in over 70 countries. Company headquarters are in Munich, Germany.

Environmental commitment

- Energy-efficient products
- Continuous improvement in environmental sustainability
- ISO 14001-certified environmental management system



Regional contact

Europe, Africa, Middle East

+49 89 4129 12345

customersupport@rohde-schwarz.com

North America

1-888-TEST-RSA (1-888-837-8772)

customer.support@rsa.rohde-schwarz.com

Latin America

+1-410-910-7988

customersupport.la@rohde-schwarz.com

Asia/Pacific

+65 65 13 04 88

customersupport.asia@rohde-schwarz.com

This application note and the supplied programs may only be used subject to the conditions of use set forth in the download area of the Rohde & Schwarz website.

R&S® is a registered trademark of Rohde & Schwarz GmbH & Co. KG; Trade names are trademarks of the owners.

Rohde & Schwarz GmbH & Co. KG

Mühl Dorfstraße 15 | D - 81671 München

Phone + 49 89 4129 - 0 | Fax + 49 89 4129 - 13777

www.rohde-schwarz.com