

Quality Measurements on Digital and Analog TV Transmitters

Using the R&S®ETL

Application Note

Products:

- R&S®ETL
- R&S®SFF
- R&S®DVM
- R&S®VSA
- R&S®UPV
- R&S®UP300

The ATV transmitter measurements are up-to-date, but the DTV transmitter measurements are not. For more updated information check the Application Notes "7BM101" (DVB-T / DVB-H), "7BM102" (ATSC) and "7BM103" (ISDB-T).

All types of information transmission, including the "one-way" transmission used in broadcasting, involve feeding a radio frequency (RF) signal to an antenna. This is the essence of the most basic type of transmitter used to emit electromagnetic waves. In the real world, however, a transmitter used for broadcast applications, for example, is much more complex in terms of its functions and design. The different transmitter components must be carefully coordinated. There are many quality parameters that are critical in ensuring that a proper output signal is delivered.

Rohde & Schwarz designed the R&S®ETL TV analyzer especially for broadcasting applications. The analyzer allows the measurement of the quality parameters that are relevant in analog and digital broadcasting. This Application Note describes the typical quality measurements performed during compliance testing of TV transmitters. The approach discussed here is based on the example of Rohde & Schwarz terrestrial transmitters for analog TV and DVB-T / DVB-H.

Table of Contents

1	Information	4
2	Overview	4
3	Scope of This Document and Requirements.....	4
4	Basic Operation of Television Transmitters.....	5
4.1	Fundamentals of analog TV	5
4.1.1	Analog baseband signal: color composite video synchronous (CCVS) signal	5
4.1.2	Analog transmission channel	5
4.2	Digital TV fundamentals: DVB-T / DVB-H	6
4.2.1	MPEG-2 transport stream	6
4.2.2	Digital terrestrial television: DVB-T / DVB-H modulation	7
4.3	Basic functioning / design of a TV transmitter	8
4.4	Rohde & Schwarz TV transmitter family	9
5	Nonlinear and Linear Distortion in the Signal Path	10
5.1	Nonlinear distortion during amplification	10
5.2	Linear distortion due to power filters	11
5.3	Precorrection at the exciter	11
6	Measurement Principle.....	13
6.1	Measurement directives	13
7	Measurements on the DVB-T / DVB-H TV Transmitter.....	14
7.1	Sample configuration	15
7.2	R&S® ETL: The most important measurements involving the DTV transmitter ...	15
7.2.1	Basic settings	16
7.2.2	Shoulder measurement in accordance with ETSI TR 101 290	17
7.2.3	Constellation diagram for qualitative signal analysis	18
7.2.4	Measured values for quantitative assessment of signal quality	19
7.2.5	Measurements on the channel	20
7.2.6	MER over frequency	21
7.2.7	Power measurement using an external power sensor	22
8	Quality Measurements on Analog TV Transmitters	23
8.1	Sample application: standard PAL B/G with two FM sound carriers	23

8.2	Sample configuration	24
8.3	R&S® ETL: The most important measurements involving the ATV transmitter ...	24
8.3.1	Basic settings	25
8.3.2	General carrier measurements using the R&S® ETL	26
8.3.3	Vision carrier measurement	27
8.3.4	Measurement of the video parameters using the R&S® VSA	27
8.3.1	Basic configuration of the R&S® VSA	28
8.3.2	Main measurement parameters for the transmitter measurement	29
8.4	Measuring the audio parameters using an audio analyzer	32
8.4.1	Measurement principle	32
8.4.2	Configuration of the generator function in the R&S® UP300	33
8.4.3	Performing audio measurements with the R&S® UP300	34
9	Abbreviations	38
10	References	38
11	Additional Information	38
12	Ordering Information	38

1 Information

This Application Note was released in 2006, the ATV measurements are still valid, but the DTV transmitter measurements covered in this Application Note (Chapter 7) are not up-to-date. Therefore Rohde & Schwarz published additional Application Notes in 2013 covering in detail all measurements on DVB-T / DVB-H transmitters, ATSC transmitters and ISDB-T transmitters. These Application Notes describe how all required transmitter measurements, from the initial acceptance testing for the transmitter, to measurements performed during commissioning and preventive maintenance can be performed with a single instrument, the R&S® ETL TV analyzer. The Application Notes can be downloaded for free from <http://www.rohde-schwarz.com>, search term: "7BM101" (DVB-T / DVB-H), "7BM102" (ATSC), "7BM103" (ISDB-T).

2 Overview

Information transmission has been an important part of our everyday lives since well before the dawn of the information age. Radio technology was born out of the experimental verification of the existence of electromagnetic waves by the German physicist Heinrich Hertz at the end of the 19th century. Modern technology used to transmit information is based on the fundamental principles that Hertz discovered.

All types of information transmission, including the "one-way" transmission used in broadcasting, involve feeding a radio frequency (RF) signal to an antenna. This is the essence of the most basic type of transmitter used to emit electromagnetic waves. In the real world, however, a transmitter used for broadcast applications, for example, is much more complex in terms of its functions and design. The different transmitter components must be carefully coordinated. There are many quality parameters that are critical in ensuring that a proper output signal is delivered.

Rohde & Schwarz designed the R&S® ETL TV analyzer especially for broadcasting applications. The analyzer allows the measurement of the quality parameters that are relevant in analog and digital broadcasting. This Application Note describes the typical quality measurements performed during compliance testing of TV transmitters. The approach discussed here is based on the example of Rohde & Schwarz terrestrial transmitters for analog TV and DVB-T / DVB-H.

3 Scope of This Document and Requirements

This Application Note discusses the basic functioning of television transmitters along with their technological principles. Examples of analog and digital (DVB-T / DVB-H) TV transmitter measurements are also discussed.

The Application Note is intended to help Rohde & Schwarz customers who need an easy introduction to the complex and far-reaching topic of TV transmitter measurements.

Please be aware that this document does not consider the technical principles of the different TV standards at length. See [1] and [2] for more information on those topics.

4 Basic Operation of Television Transmitters

A television transmitter is used to emit a television signal containing video and audio information. Depending on whether analog or digital transmission of the TV content is used, we will encounter different baseband signals and modulation types.

4.1 Fundamentals of analog TV

The analog baseband signal ("color composite video synchronous signal") is fed to a vestigial sideband modulator.

4.1.1 Analog baseband signal: color composite video synchronous (CCVS) signal

The color composite video synchronous signal carries the luminance and chrominance information. Besides luminance and chrominance information, sync pulses are also part of the signal. These pulses ensure that specific lines for specific pictures in the TV signal are displayed properly: Horizontal syncs can be thought of as "line breaks" while vertical syncs indicate the beginning of a TV picture. A line consists of a horizontal sync pulse, indicating the beginning of a line. The color information is modulated onto a color subcarrier. A color burst is transmitted to allow recovery of the color information.

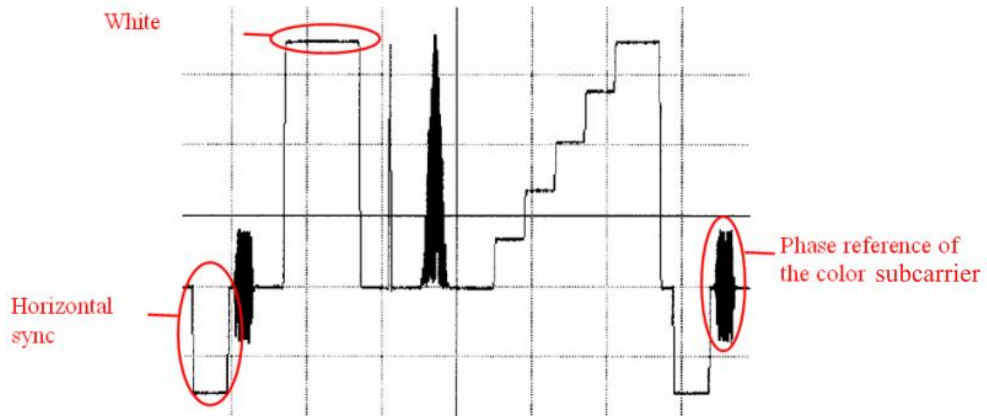

Fig. 1: The CCVS signal

4.1.2 Analog transmission channel

For radio transmission of the television signal, an RF carrier (vision carrier) is amplitude-modulated with the composite video signal. In order to save bandwidth, the lower sideband bandwidth is reduced (vestigial sideband transmission).

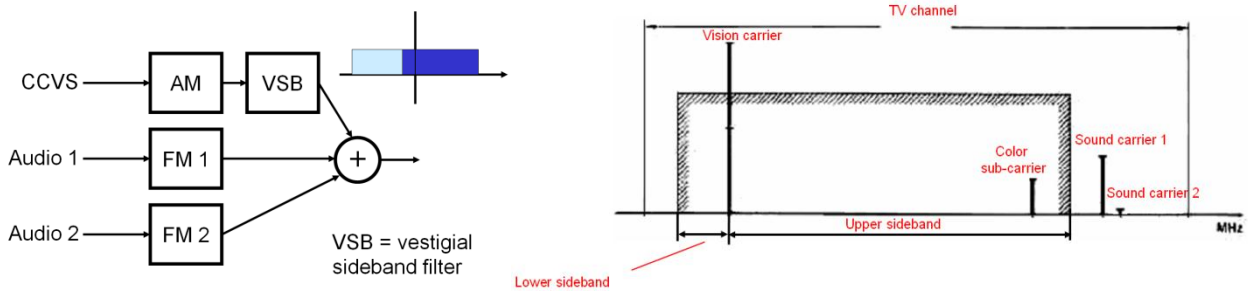

Fig. 2: Analog TV modulation / signal spectrum

In order to have sound that matches the video, up to two sound carriers can be part of the TV channel. These sound carriers are modulated in various ways. The analog or digital modulated sound carriers allow mono, dual, or stereo sound reception.

4.2 Digital TV fundamentals: DVB-T / DVB-H

In the case of digital television, the video and audio information is digitized and compressed to reduce the amount of data (e.g. MPEG-2). The transport stream obtained by multiplexing is then fed to the OFDM modulator.

4.2.1 MPEG-2 transport stream

Nowadays, extremely large quantities of data are transmitted globally via cable, satellite, and terrestrial links. Limitations on bandwidth make it necessary to optimally exploit available capacity. This is why compression mechanisms such as MPEG-2 ISO/IEC 13818 were developed.

For example, this standard achieves a reduction in the data rate for video and audio transmission by removing unnecessary and redundant data. Unnecessary information is information that cannot be perceived by the human senses. Redundant information exists more than once.

The following figure (Fig. 3) illustrates the basic principles involved in the generation and transmission of digital television signals:

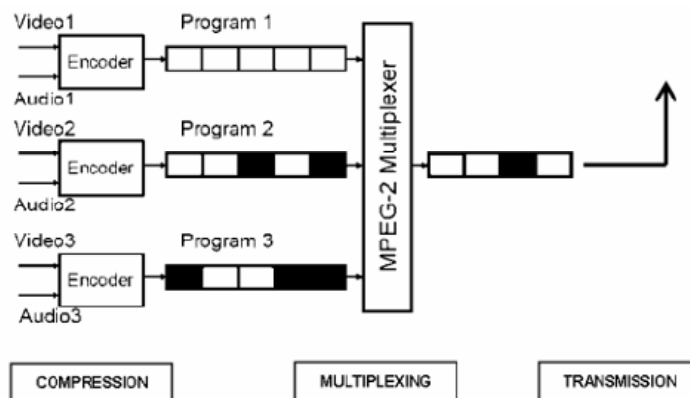

Fig. 3: Transport stream generation

To be able to transmit multiple services via a single channel, the content of each program is split into small packets after compression (encoder). These packets are “multiplexed” into one stream with a constant bit rate. In accordance with the ISO/IEC 18131 standard, what is known as an “MPEG-2 transport stream” is generated. This content is fed to the transmitter.

4.2.2 Digital terrestrial television: DVB-T / DVB-H modulation

In the terrestrial transmission standard DVB-T (ETS 300 744), the use of coded orthogonal frequency division multiplexing (COFDM) makes it possible to compensate for interference that occurs during terrestrial transmission such as pulse interference or multipath propagation. Here, the basic concept involves dividing a data stream with error protection among several thousand subcarriers that use quadrature modulation.

The individual carriers must not influence one another. A modulated carrier should reach its maximum value only when the adjacent carriers are at a spectral zero crossing.

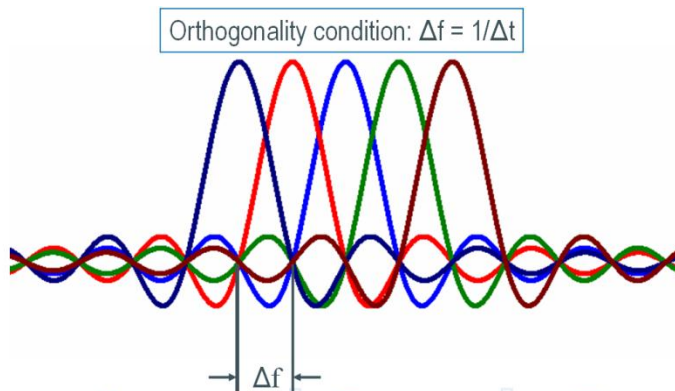

Fig. 4 Basic principle of OFDM

The following spectrum is produced:

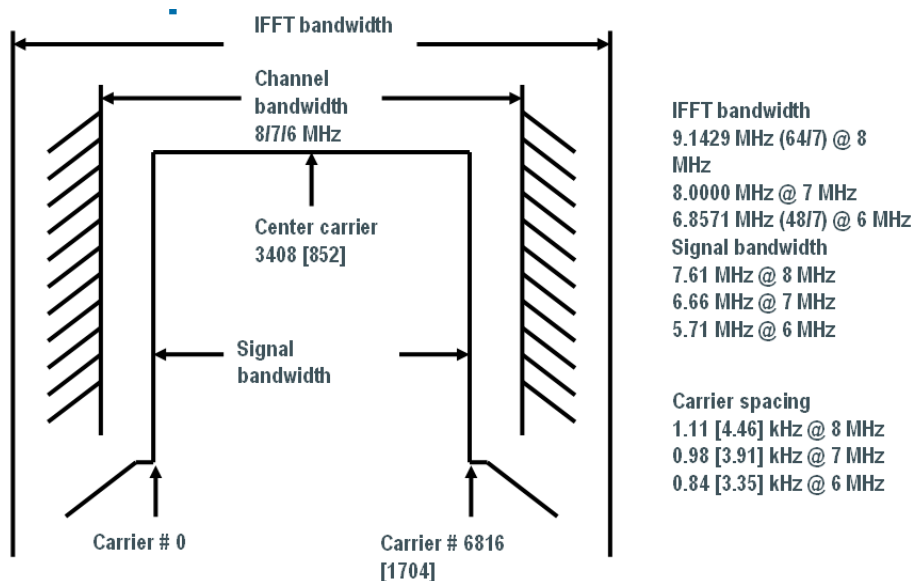

Fig. 5: DVB-T spectrum

4.3 Basic functioning / design of a TV transmitter

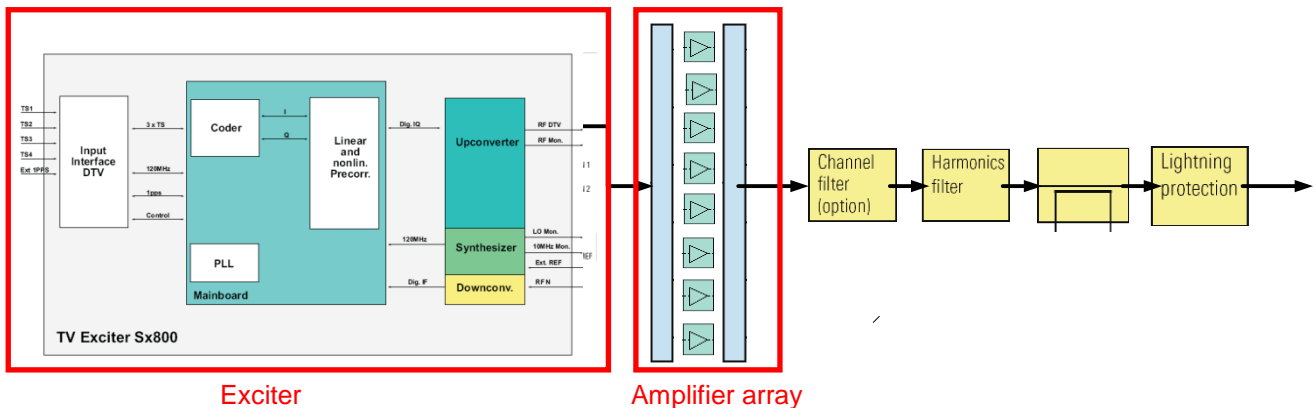

Fig. 6: Block diagram of a TV transmitter

As we can see from Fig. 6, a TV transmitter contains various components:

■ **Exciter:**

The exciter performs signal conditioning for the RF signal to be transmitted. The input signal (CCVS or MPEG-2 transport stream) is modulated onto a carrier signal at a certain frequency (channel frequency).

■ **Amplifier array:**

Using parallel LDMOS amplifiers, the RF signal generated by the exciter is amplified. Due to the high power levels required to transmit a signal over a long distance, the signal is split among several amplifier paths. Following the amplification process, the resultant signal paths are summed together with the proper phase to produce the high-power output signal.

■ **Channel filter (also referred to as power filter or mask filter):**

One basic requirement for the TV transmitter is that it must output only a single modulated signal in a selected channel. The adjacent channels must not be influenced or disrupted. Channel filters are used to ensure compliance with this requirement.

■ **Harmonics filter:**

Like the channel filter, the harmonics filter is used to prevent harmonics from disrupting other channels (multiples of the desired transmit frequency) in the frequency spectrum. The transmit signal should consist solely of the fundamental.

■ **Directional coupler:**

A directional coupler is used to decouple part of the output power for test purposes (typically 30 dB to 60 dB). This is necessary since the full output power would immediately destroy the test instrument.

■ **Lightning protection:**

Transmitter facilities have lightning protection to protect the transmitter and its components from lightning strikes.

4.4 Rohde & Schwarz TV transmitter family

To meet a wide variety of different requirements posed by different regional applications, Rohde & Schwarz offers many different classes of transmitters.

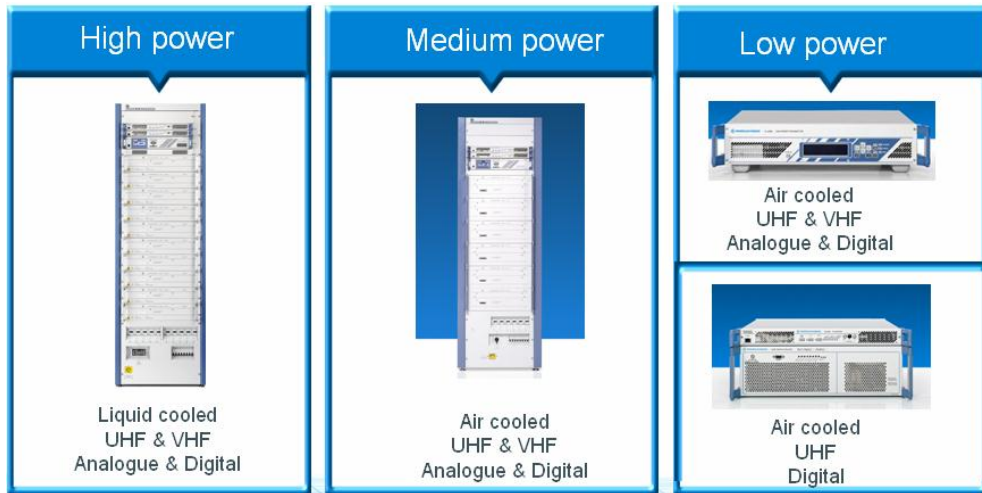

Fig. 7: Rohde & Schwarz product portfolio

5 Nonlinear and Linear Distortion in the Signal Path

The amplification process in the output stages of the TV transmitter as well as the optional power filter result in distortion in the actual output signal. However, this distortion must be eliminated from the signal that is transmitted, which is why precorrectors are used in the exciters.

5.1 Nonlinear distortion during amplification

The amplifiers consist of laterally diffused metal oxide semiconductor field effect transistors (LDMOS). Due to their characteristic, such transistors can amplify the incoming signal from the exciter:

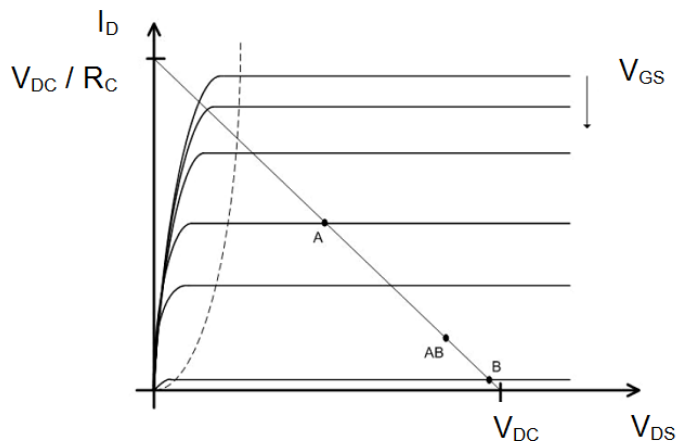

Fig. 8: Output characteristic (schematic)

There are several different modes (Fig. 8):

- A-mode:

In A-mode, the operating point is in middle of the characteristic's linear part. A high quiescent current is produced. In this mode a single amplifier stage only achieves a maximum power added efficiency of 50%. One big advantage is the low distortion of the signal to be amplified.

- B-mode:

Here, the operating point of the transistor is in the lower region of the characteristic. Compared to amplifiers in A-mode, the power added efficiency is higher and the quiescent current is lower.

- AB-mode:

Amplifiers in AB-mode have a marginally higher quiescent current than B-mode amplifiers. This type of amplifier represents the compromise between distortion and gain. This type is used primarily in the consumer electronics industry in either IC or discrete implementations.

- C-mode (not shown in Fig. 8):

With this type of power amplifier, strong distortion of the signal is prevalent. This is due to the fact that an operating point is chosen that results in zero quiescent current for small input signals. The major benefit of this type of amplifier is the relatively high power added efficiency of up to 90% for a single stage.

For economical operation, the amplifiers are operated in their higher-efficiency range (AB). This results in nonlinear distortion of the signal. In other words, the instantaneous gain and phase shift of the signal change in response to variations in the drive. This creates spurious frequencies in the signal spectrum. Looking at the analog television signal, nonlinear distortions result in incorrect luminance and chrominance information.

5.2 Linear distortion due to power filters

The power filters at the transmitter output create linear phase and amplitude distortion on the filter edges that can reduce the signal/noise ratio. In case of linear distortion, the amplitude as well as the group delay for a specific frequency range is not constant. Looking at the analog television signal, linear distortion results in a sort of slurring of the waveform.

5.3 Precorrection at the exciter

To prevent distortion of the generated transmit spectrum, the exciter has two precorrection units as shown in Fig. 9:

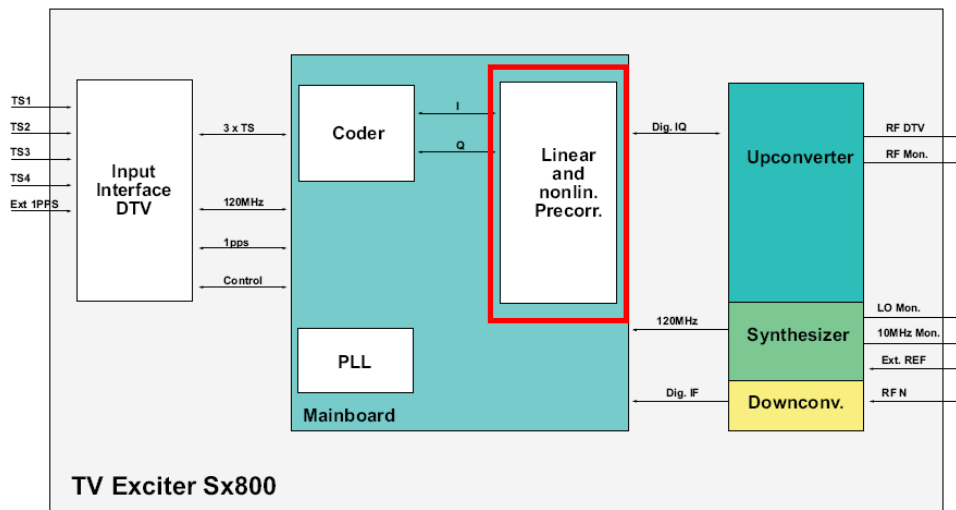

Fig. 9: The precorrection units in the exciter

- Linear pre-correction:

The linear pre-correction corrects the amplitude and phase response of the signal so that distortion caused by the output filter is canceled out.

- Nonlinear pre-correction:

The nonlinear pre-correction corrects the driven signal so that distortion caused by the amplifier stage is corrected.

The basic principle behind pre-correction is as follows: Distortion is fed into the amplifier path that corresponds to the exact inverse of the distortion caused by the amplifier and/or a power filter. In the ideal case, the resulting transmit spectrum exhibits as little distortion as possible.

One major quality criterion for TV transmitters is how well the exciter and the amplifier/power filter are matched to one another.

6 Measurement Principle

As discussed above, we must ensure that there is an acceptable (i.e. undistorted) signal at all times behind the critical components represented by the amplifier and power filter.

This makes these measurement points important. If standby systems are available, compliance with the quality parameters at these measurement points must be ensured for each exciter. This results in the following measurement procedure:

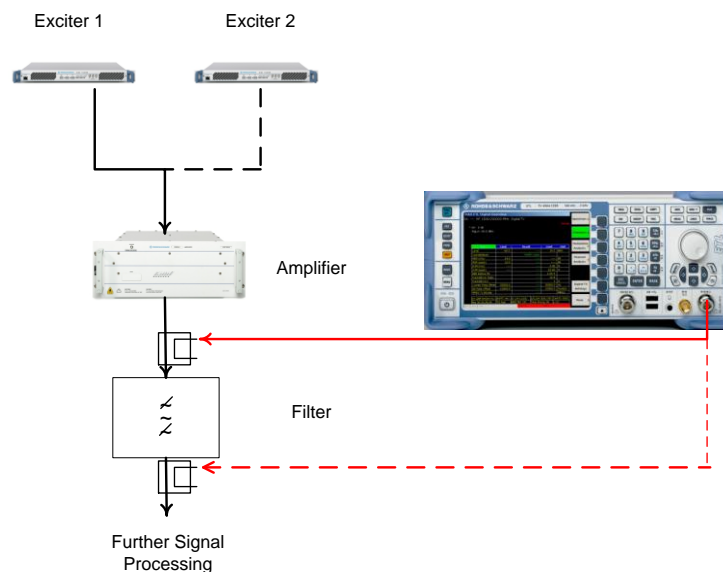

Fig. 10: Measurement points

A directional coupler must always be used to measure the transmitted signal at the measurement points. A directional coupler decouples a fraction of the actual signal power from the signal path. Analysis of this decoupled component of the signal is performed using test instruments. Typical coupling attenuations are in the order of 30 dB to 60 dB (i.e. 1/1000 to 1/1000000 of the output power).

The maximum input level for the R&S® ETL test receiver is 20 dBm. By decoupling only a fraction of the power as described above, it is possible to measure quality and operating parameters "in-service" even on high-power transmitters. Typical directional couplers have two test ports for measuring the forward and the reflected signal of the transmitter.

6.1 Measurement directives

Particularly for measurements on TV transmitters, there exist country-specific as well as customer-specific test specifications or requirement specifications that are commonly used during transmitter compliance testing on site or by manufacturers. In this document, we have attempted to orient the reference values we specify toward the relevant specifications.

7 Measurements on the DVB-T / DVB-H TV Transmitter

Due to the use of digital transmission in this case, it is possible to determine the quality of a digital TV signal using only a few measurements. In addition to measurements on the RF signal, it is only necessary to determine the bit error ratio for the baseband signal.

A typical test setup which is also used for transmitter compliance testing is shown in Fig. 11.

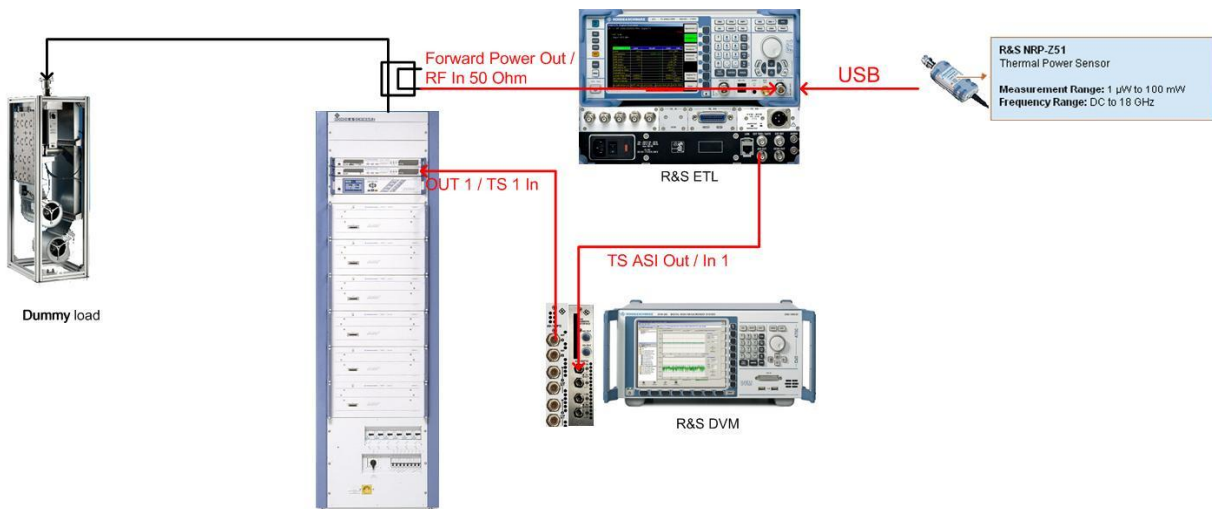

Fig. 11: DVB-T / DVB-H test setup

An MPEG-2 transport stream source (such as the R&S[®] DVM400) generates the test sequences that are fed to the TV transmitter's exciter. The R&S[®] ETL test receiver makes the measurements on the RF signal and outputs the demodulated data signal on an ASI output. The R&S[®] NRP-Z51 thermal power sensor determines the average power of the modulated RF signal. The R&S[®] DVM400 MPEG analyzer can now analyze and decode the MPEG-2 transport stream signal present at the ASI output of the test receiver.

Instead of using the R&S[®] DVM400 the MPEG-2 transport stream can be also generated by the R&S[®] ETL using the built-in R&S[®] ETL TS generator (Option R&S[®] ETL-B280 & R&S[®] ETL-K280). In addition the R&S[®] ETL can analyze the MPEG-2 transport stream using the built-in R&S[®] ETL MPEG Analysis. For more information see Application Note 7BM101 - DVB-T / DVB-H Transmitter Measurements for Acceptance, Commissioning and Monitoring.

The measurement on the transmitter can be performed "in-service" if the required test outputs are available on directional couplers. Alternatively, it is necessary to ensure during offline measurements that the entire output power is handled by an absorber (dummy load).

7.1 Sample configuration

As shown in Fig. 11, a setup for TV transmitter compliance testing can be built using two instruments. A sample configuration might look as follows:

R&S®DVM400: minimum configuration		
Designation	Type	Order-No.
Digital Video Measurement System	R&S®DVM400	2085.1800.03
MPEG Analysis Board	R&S®DVM400-B1	2085.5505.02
TS Generator	R&S®DVM400-B2	2085.5511.02
TS-Monitoring	R&S®DVM-K1	2085.5211.02
Data Broadcast Analysis	R&S®DVM-K11	2085.5311.02
DVB-H Stream Library	R&S®DV-DVBH	2085.8704.02

R&S®ETL: minimum configuration		
Designation	Type	Order-No.
TV Analyzer, 500 kHz to 3 GHz, with tracking generator	R&S®ETL	2112.0004.13
DVB-T/DVB-H Firmware	R&S®ETL-K240	2112.0556.02
OCXO Reference Frequency ¹	R&S®FSL-B4	1300.6008.02
Power Sensor Support	R&S®FSL-K9	1301.9530.02
Thermal Power Sensor 0 Hz to 40 GHz, 100 mW	R&S®NRP-Z51	1138.0005.02
One of the following three power sensor interfaces		
■ Additional interfaces	R&S®FSL-B5	1300.6108.02
■ Active USB Adapter	R&S®NRP-Z3	1146.7005.02
■ Passive USB Adapter	R&S®NRP-Z4	1146.8001.02

7.2 R&S®ETL: The most important measurements involving the DTV transmitter

The digital TV analyzer provides different test screens: spectrum, overview, modulation analysis, and channel analysis. Please proceed as follows to launch the TV analyzer function provided in the R&S®ETL:

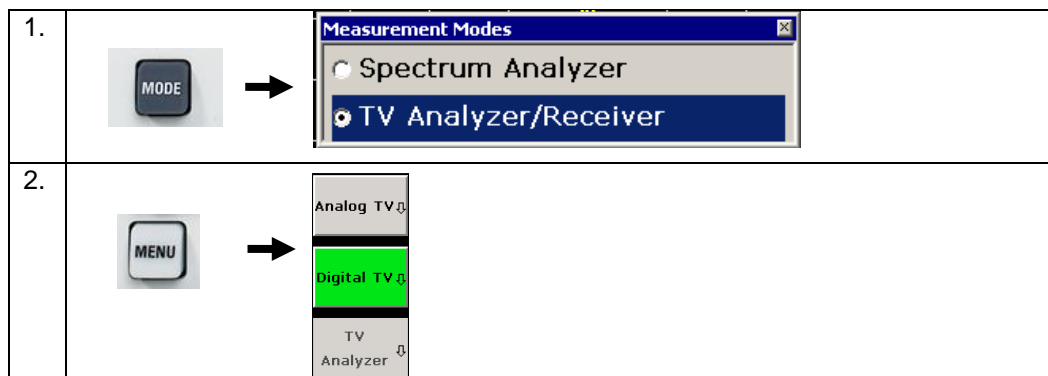

¹ Only, if no external 10 MHz reference is used

7.2.1 Basic settings

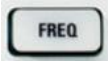
1. Use the **FREQ** key  to configure the channel center frequency.
2. Before you can begin analysis of the DTV signal, you need to make some basic settings in the "Digital TV Settings" menu:

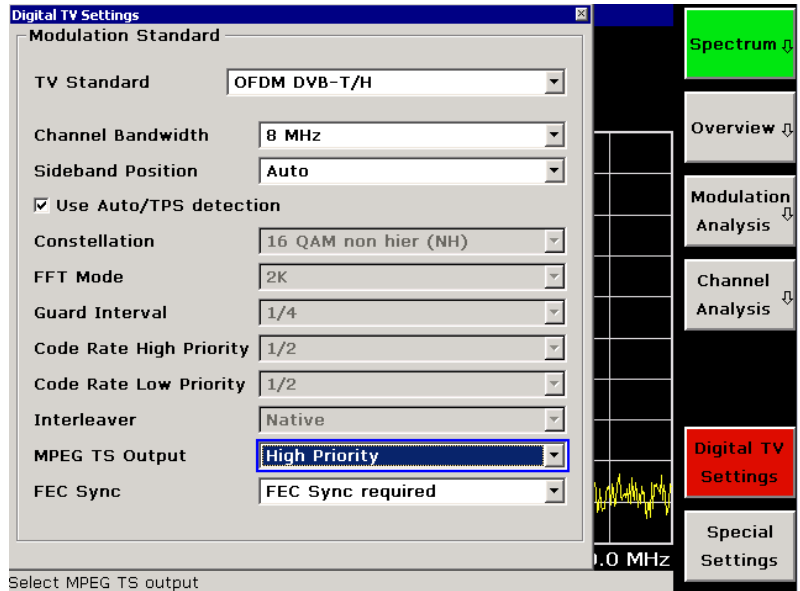

To enable measurements that are specially optimized for transmitter compliance testing, you must change "System Opt." and "Symbol Loop" in the "Special Settings" menu to "Slow/Laboratory" and "Low", respectively.

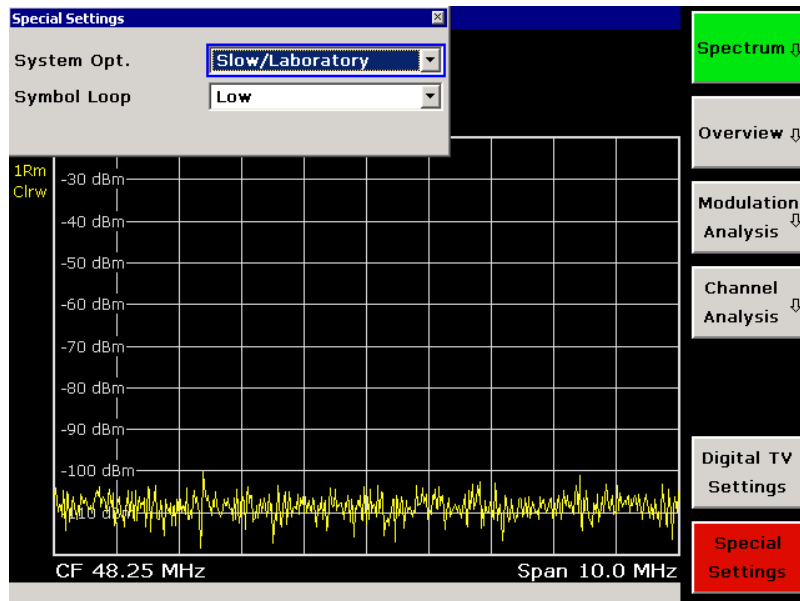

7.2.2 Shoulder measurement in accordance with ETSI TR 101 290

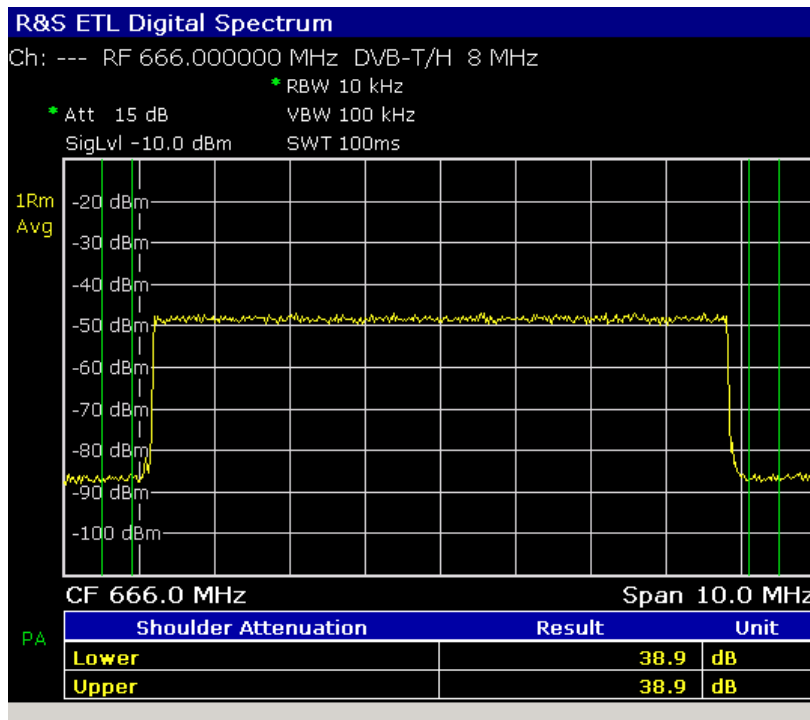

Fig. 12: Shoulder measurement in accordance with ETSI TR 101 290

In the "Spectrum" test screen, spurious emissions can be analyzed in the upper and lower adjacent channels using the "Shoulder Attenuation" measurement function. In the case of DVB-T / DVB-H, this measurement is performed in accordance with the ETSI standard TR 101 290. An asymmetrical shoulder and high emissions in the adjacent channels are an indication of poor signal quality.

Reference value:

At the measurement point between the power amplifier and the output filter, a shoulder ratio of greater than 37 dB is typically measured.

7.2.3 Constellation diagram for qualitative signal analysis

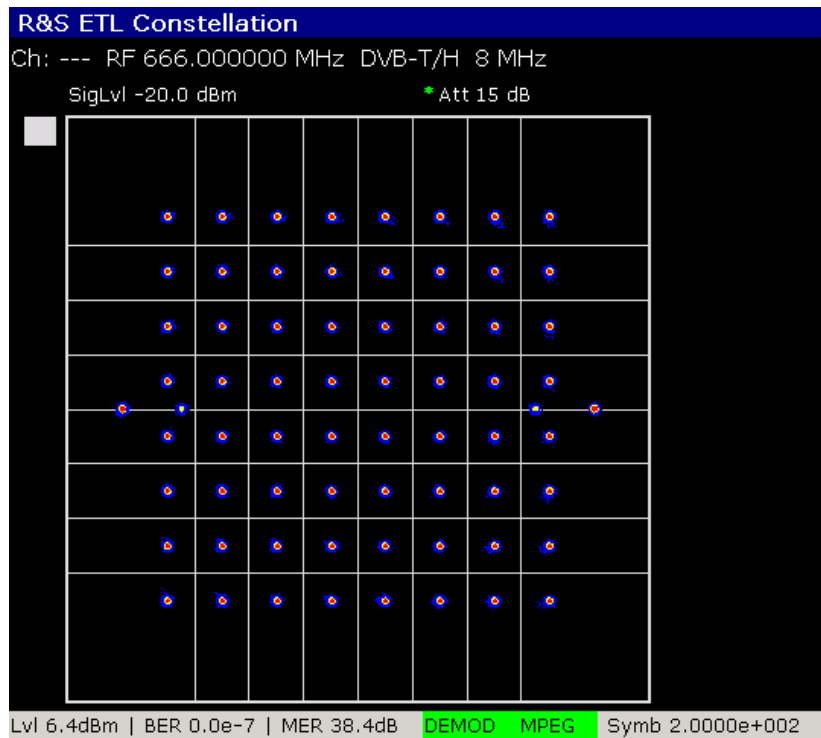

Fig. 13: Constellation diagram

Using the constellation diagram in the "Modulation Analysis" test screen, you can display the signal states that occurred in quadrature modulation in discrete time intervals. The constellation diagram is a graphical representation of the in-phase and quadrature components of a QAM signal in the X and Y axes. In the case of modulation with multiple carriers, the constellation diagram typically forms the sum of the signal states of all of the carriers. A noisy or disrupted DVB-T / DVB-H signal will exhibit cloud-like effects. The smaller the resulting constellation points on the detection areas, the better the signal quality. When making measurements directly on the transmitter, only fine constellation points should be visible.

7.2.4 Measured values for quantitative assessment of signal quality

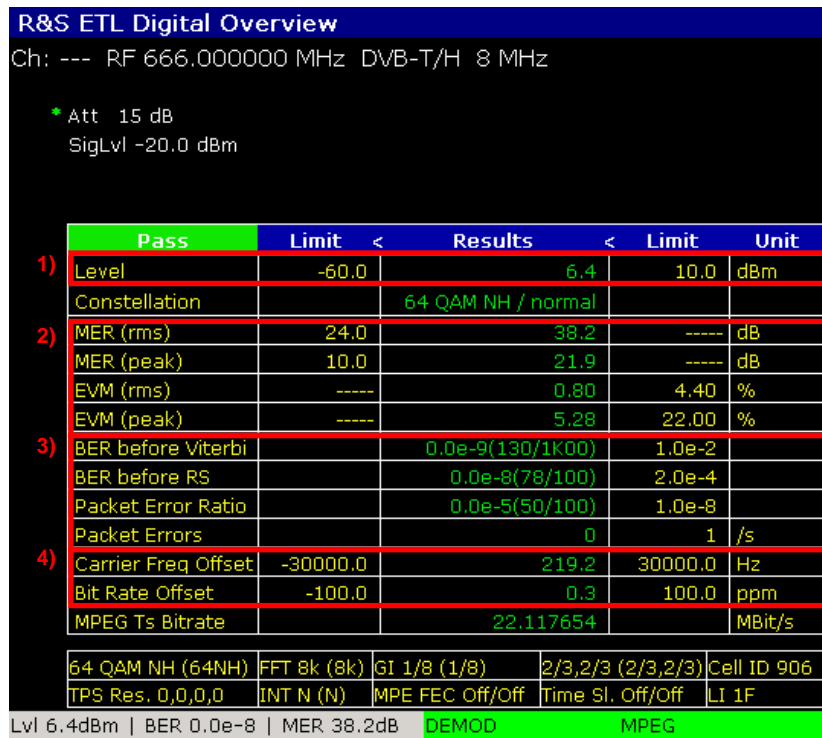

Fig. 14. DVB-T / DVB-H overview measurements

This screen shows the current measurement result for a number of RF and baseband parameters and also allows specification of limits.

1) Level

The "Level" value indicates the average power of the digitally modulated signal at the input of the R&S®ETL. Note that the displayed power only reflects the decoupled power on the directional coupler. The measurement uncertainty is equal to <1.0 dB. If you need more precise power measurements, we recommend using an external thermal sensor.

2) Modulation quality

The modulation error ratio (MER) and the error vector magnitude (EVM) can be used for quantitative assessment of the constellation points in the constellation diagram with regard to their deviation from the theoretical location. Here, you can select the MER (RMS) and EVM (RMS) as measurement parameters. The greater each of these two values is, the better the signal quality.

$$MER_{RMS(dB)} = 20 \cdot \lg\left(\frac{\sqrt{\frac{1}{N} \sum_{n=0}^{N-1} (|error_vector|)^2}}{U_{RMS}}\right) [dB];$$

R&S®ETL: The most important measurements involving the DTV transmitter

$$EVM_{RMS(dB)} = 20 \cdot \lg\left(\frac{\sqrt{\frac{1}{N} \sum_{n=0}^{N-1} (|error_vector|)^2}}{U_{Peak}}\right) [dB];$$

Reference value:

The MER (RMS) should have a value greater than 35 dB when measured behind the output filter.

3) Bit error ratios (BERs)

With the terrestrial digital transmission system DVB-T / DVB-H, there are two essential error protection mechanisms: the Viterbi decoder and the Reed-Solomon decoder. Both techniques are designed to detect and correct bit errors that occur in the data stream during transmission. Under optimum conditions (such as measurements made directly at the transmitter output), the bit error ratio before Viterbi (i.e. before any error correction) should be equal to zero.

4) Carrier frequency offset and bit rate offset

Carrier frequency offset is the difference between the receive frequency set in the RF menu and that internally measured. In this manner, any problems with the oscillators can be determined.

The bit rate of the transmitted signal essentially determines the transmission parameters of the DVB-T signal. It directly influences the following parameters:

- Frequency spacing of individual carriers in the OFDM spectrum
- Symbol period
- Absolute length of the guard interval

The bit rate of a DVB-T transmitter should therefore lie within very tight limits (± 20 ppm) to ensure error-free operation.

7.2.5 Measurements on the channel

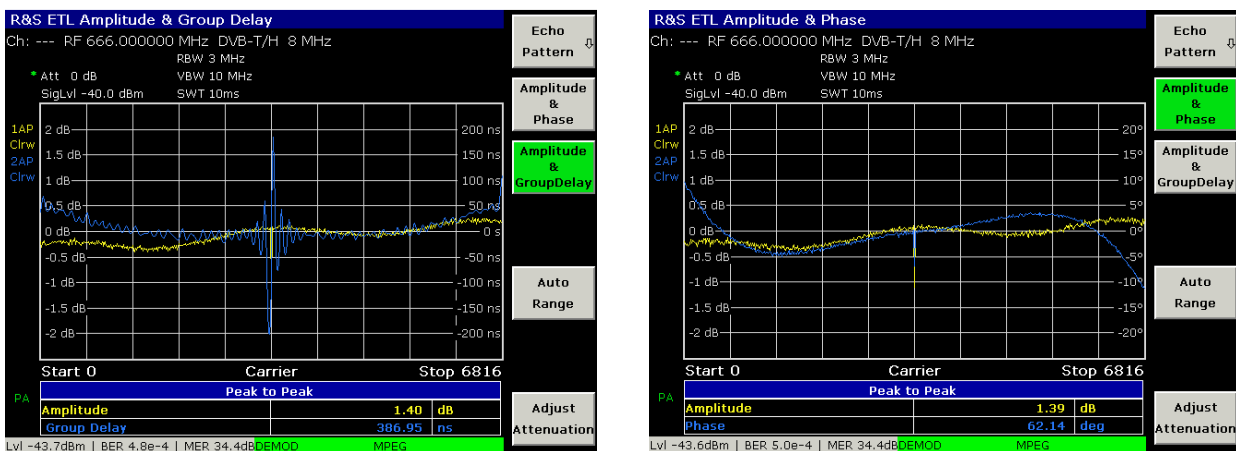

Fig. 15: Amplitude & group delay and amplitude & phase measurement (shown with residual carrier problem)

R&S®ETL: The most important measurements involving the DTV transmitter

The R&S®ETL test receiver is equipped with a powerful channel estimation feature that evaluates the pilots contained in the DVB-T signal and computes information about the linear distortion in the transmission channel based on the amplitude or phase shift.

You can select the following measurements:

- Amplitude frequency response and phase frequency response
- Amplitude frequency response and group delay frequency response

When making measurements after the power filter, these two measurements are critical. As described in section 4, linear distortion occurs in this case that must be precorrected in the exciter.

7.2.6 MER over frequency

The frequency-dependent curve of the modulation error (MER) can be calculated with the R&S®ETL and displayed on its screen. For calculation of the parameters, all pilots (TPS, continual, and scattered pilots) are automatically removed from the data material. If only such a pilot is selected, an error message is output.

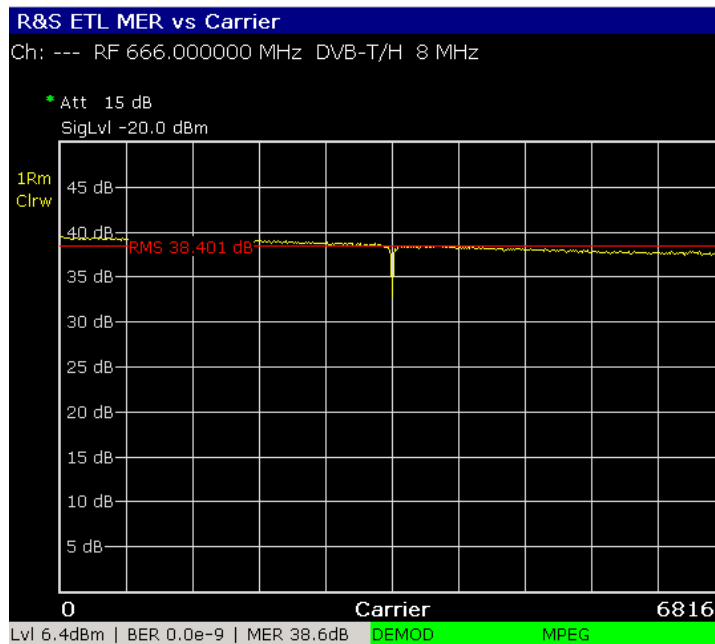
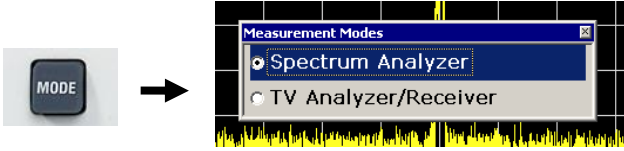
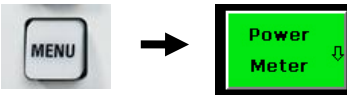
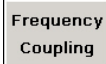
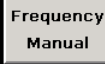
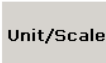
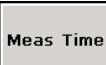
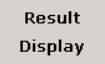
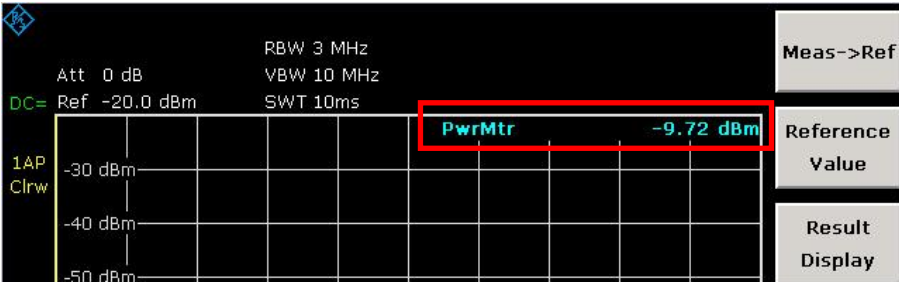
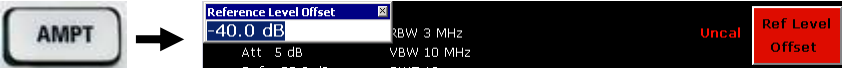

Fig. 16. MER over frequency measurement screen

Normally, the MER(f) graph should not exhibit any peaks. A peak at the central carrier would indicate a problem with a residual carrier, for example.

7.2.7 Power measurement using an external power sensor

1.	<p>Select the spectrum analyzer mode using the "Mode" button.</p> 
2.	<p>Click "Menu" to switch to "Power Meter" mode.</p> 
3.	<p>Press the "Frequency Coupling" softkey  to select the coupling option (Center, Marker) or alternatively press the "Frequency Manual" softkey  to enter the frequency of the signal for which you wish to measure the power.</p>
4.	<p>You can use the "Unit/Scale" softkey  to select the display unit for the power measurement. You can choose between relative and absolute units.</p>
5.	<p>By clicking "Meas Time" , the measurement time for a power measurement can be varied: The optimal setting for measurements on digital signals is "Normal".</p>
6.	<p>You can use  to turn power display in the spectrum screen on or off:</p> 
7.	<p>To take into account the coupling attenuation of the directional coupler in the power display, you can use "AMPT" to enter a reference level offset that is equal to the coupling attenuation.</p> 

8 Quality Measurements on Analog TV Transmitters

The following section discusses quality measurements on ATV transmitters based on the example of a transmitter using the standard PAL B/G and two FM-modulated sound carriers. Measurements based on the standard L and/or SECAM cannot be performed using the R&S®ETL and the video analyzer employed here.

8.1 Sample application: standard PAL B/G with two FM sound carriers

Measuring and assessing quality parameters for analog TV transmitters is considerably more complex than for digital TV transmitters. Due to the analog transmission technique, consideration of the RF level alone accompanied by a bit error ratio measurement is not sufficient.

In addition, it is necessary to check the analog video and audio signal in detail. For this purpose, the R&S®ETL has outputs for a CCVS signal and the audio signal (Lemo Triax female, paired). To analyze these signals you also require a video signal analyzer such as the R&S®VSA and an audio analyzer such as the R&S®UPV or R&S®UP300.

Since the transmitter must be operated at nominal power during compliance testing, it is connected to an absorber which handles the power that is delivered. A CCVS signal generator such as the R&S®SFF is used as the video signal source. For generating the audio signal, the generator option for the R&S®UPV or R&S®UP300 can be employed.

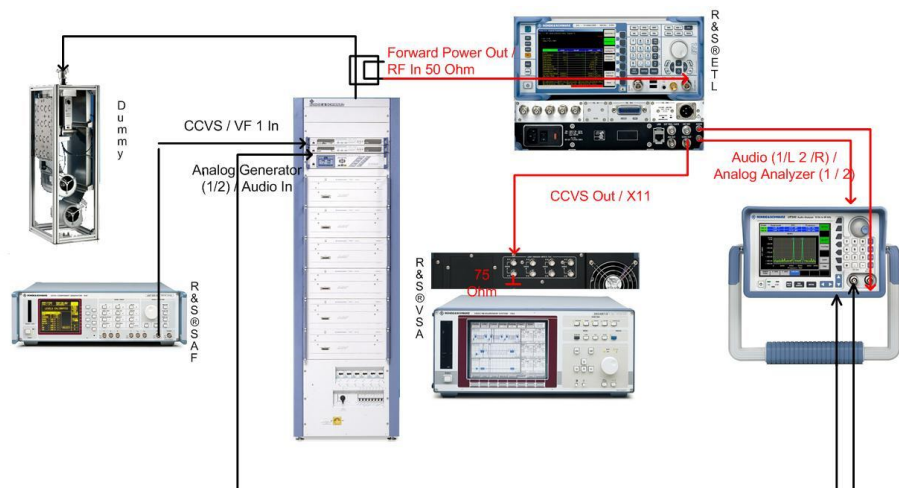

Fig. 17: Test setup for transmitter quality measurement (here, measurement directly after the amplifier)

Due to the many existing standards for video and audio transmission and the numerous measurements they entail, this section will be limited to listing and explaining the most important parameters. The measurement parameters can be classified as RF, video, or audio parameters.

8.2 Sample configuration

As seen in Fig. 17, we can build a setup for quality measurements on analog TV transmitters (standard B/G, PAL) using the following instruments:

Instrument	Designation	Order No.
R&S®ETL	TV Analyzer, 500 kHz to 3 GHz, with tracking generator	2112.0004.13
R&S®UP300	Audio Analyzer 10 Hz to 80 kHz, analog and digital interfaces	1147.2494.03
R&S®VSA	Video Measurement System Standards B/G/I/D/K with color display	2013.6057.04
R&S®SFF	Multistandard CCVS Generator	2007.1057.02

8.3 R&S®ETL: The most important measurements involving the ATV transmitter

Please proceed as follows to launch the TV analyzer function provided in the R&S®ETL:

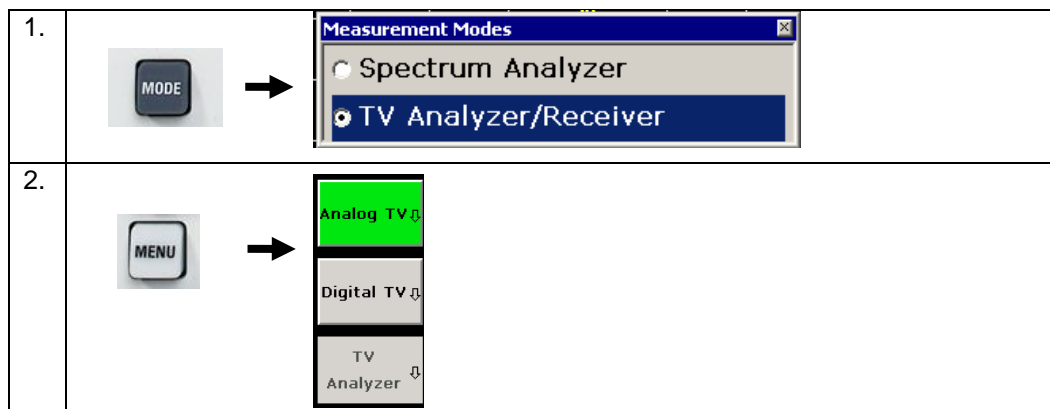

The analog TV analyzer mode provides different test screens including spectrum, carrier, vision modulation, etc.

8.3.1 Basic settings

1. Use the **FREQ** key  to configure the vision carrier frequency.
2. Before you can begin analysis of the ATV signal, you need to make some basic settings in the "Analog TV Settings" menu:

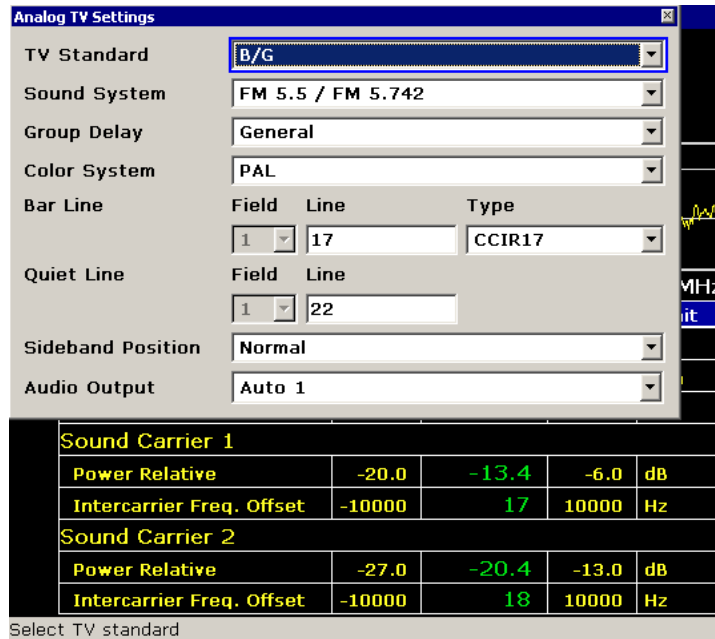

Sound Carrier 1				
Power Relative	-20.0	-13.4	-6.0	dB
Intercarrier Freq. Offset	-10000	17	10000	Hz
Sound Carrier 2				
Power Relative	-27.0	-20.4	-13.0	dB
Intercarrier Freq. Offset	-10000	18	10000	Hz

Select TV standard

3. To ensure optimized analysis of the analog TV signal, choose "Synchronous PLL Sample Back Porch Slow" in the "Vision Detector" menu:

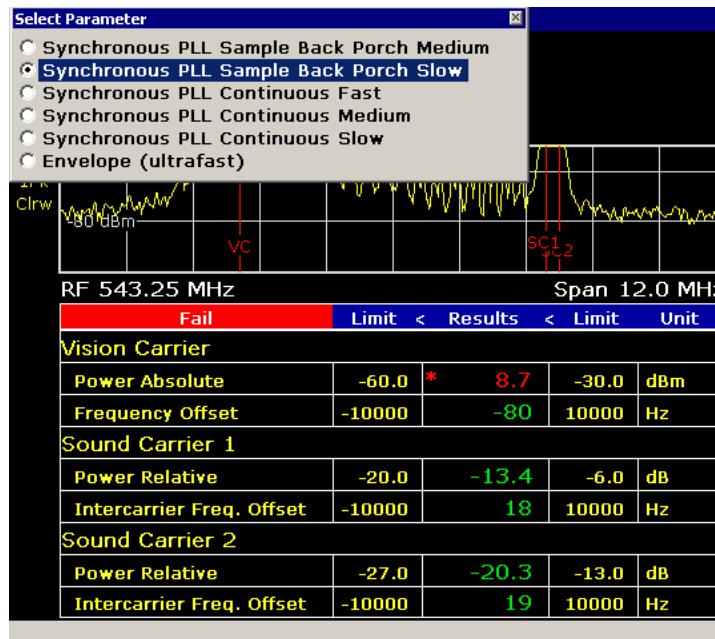

	Fail	Limit	Results	Limit	Unit
Vision Carrier					
Power Absolute	-60.0	*	8.7	-30.0	dBm
Frequency Offset	-10000		-80	10000	Hz
Sound Carrier 1					
Power Relative	-20.0		-13.4	-6.0	dB
Intercarrier Freq. Offset	-10000		18	10000	Hz
Sound Carrier 2					
Power Relative	-27.0		-20.3	-13.0	dB
Intercarrier Freq. Offset	-10000		19	10000	Hz

8.3.2 General carrier measurements using the R&S®ETL

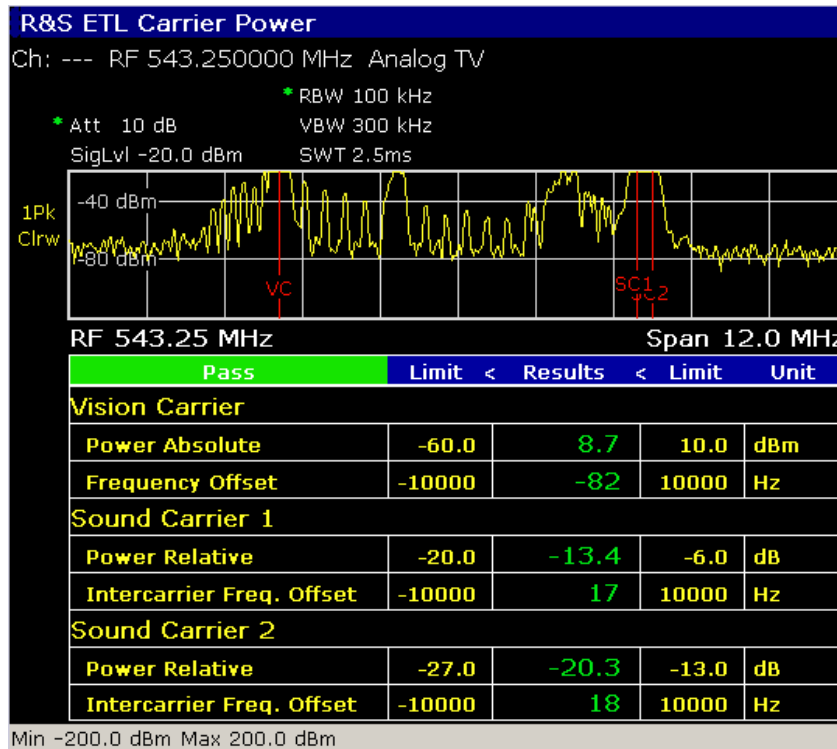

After you select the "Carriers" softkey, the relative frequency offset and power values for the sound carriers are measured in addition to the frequency offset and power of the vision carrier.

Reference value:

1. The frequency stability of the vision carrier should ensure a maximum drift of ± 150 Hz.
2. The frequency stability of the sound carriers should exhibit a maximum drift of ± 500 Hz.
3. The relative power of the sound carriers should be 13 dB ± 1 dB relative to the peak envelope power of the vision carrier.
4. The relative power of the sound carriers should be 20 dB ± 1 dB relative to the peak envelope power of the vision carrier.

8.3.3 Vision carrier measurement

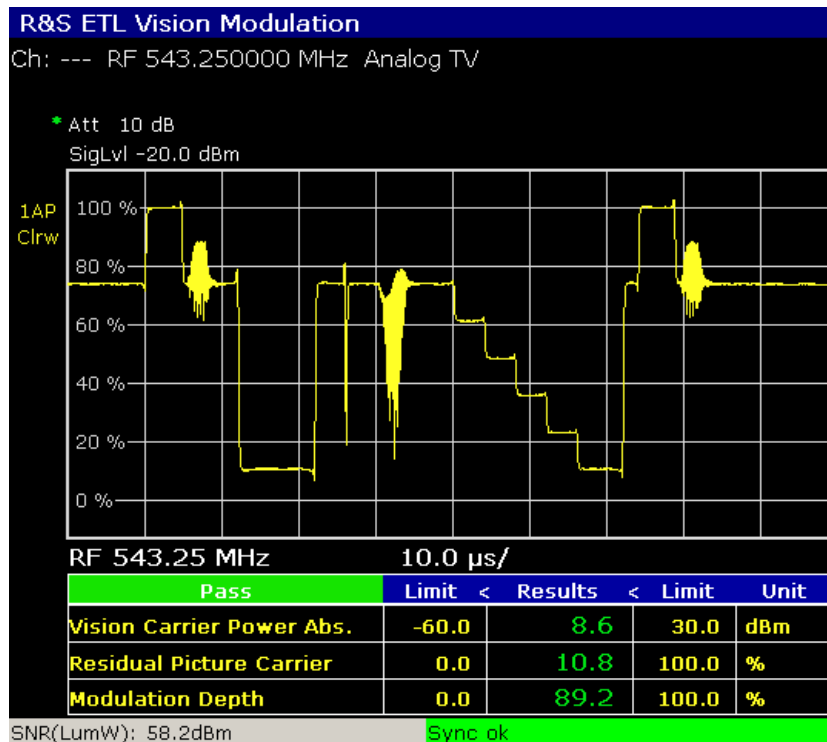

Using the "Vision Modulation" menu item, the residual carrier and the modulation depth are measured in addition to the peak envelope power of the TV signal.

Reference value:

With the B/G standard, the residual carrier should equal 11% ±1%.





8.3.4 Measurement of the video parameters using the R&S®VSA

For the setup in Fig. 17, one of the four video loop-through inputs of the R&S®VSA is required. The CCVS signal output by the R&S®ETL is fed to input A of the R&S®VSA and the loop-through input is terminated with 75 Ohm:





8.3.1 Basic configuration of the R&S®VSA

1. **Setting the TV standard:**



- Press the SETUP key .
- Use the arrow keys  to move to the "VideoStandard" menu column and press the ENTER key .
- Use the cursor keys to select the desired TV standard with ENTER  and with ESC .





2. **Setting the signal input:**

- Press the FUNCTION key .
- Use the arrow keys  to move to the "Input" menu column.
- Move the marker bar with the arrow keys to "Input A".
- Press the ENTER key .

Measure	Average	Ref	Input	Sync	Standard
Group	1 → Off	Off	A	Internal	B/G PAL
Parameter	Value	Unit	Sta	Test Signal	Line
Lum Bar Ampl (abs)	698.5	mV		CCIR17	17
Lum Bar Ampl (nom)	-0.2	%/nom		CCIR17	17
Sync Ampl (abs)	297.4	mV		CCIR17	17

3. **Setting the sync input:**

- Press the FUNCTION key .
- Use the arrow keys  to move to the "Sync" menu column.
- Move the marker bar with the arrow keys to "Internal".
- Press the ENTER key .

4. Setting the measurement parameters:
- Press the FUNCTION key .
 - Use the arrow keys  to move to the "Measure" menu column.
 - Move the marker bar with the arrow keys to "Selected Group" in the upper setting field and press the ENTER key .
 - Move the marker bar with the arrow keys to the "Select Group ..." submenu and press the ENTER key .
 - You can now set the desired measurement parameters in the submenus that will appear.

8.3.2 Main measurement parameters for the transmitter measurement

By measuring the CCVS signal, we should be able to detect any linear or nonlinear distortion.

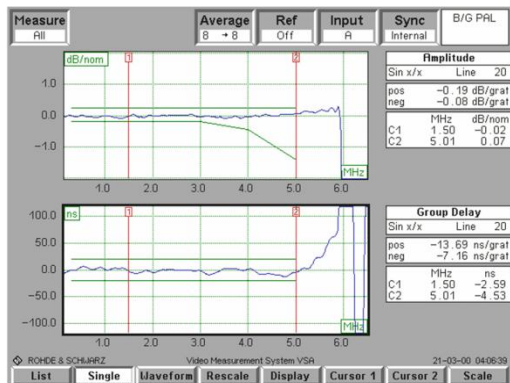
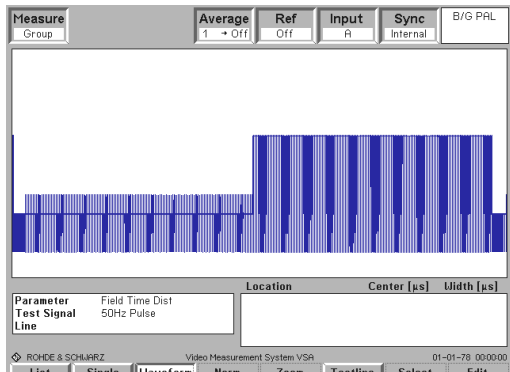
	Test signal	R&S® VSA test screen	Tolerance
Delay / transient response			
Amplitude and group delay response	sinx/x		<ul style="list-style-type: none"> ▪ Group delay peak-peak: max. 60 ns
Field time distortion	50 Hz rectangular pulse		<ul style="list-style-type: none"> ▪ Max. 2% tilt referenced to the step amplitude

Quality Measurements on Analog TV Transmitters

R&S®ETL: The most important measurements involving the ATV transmitter

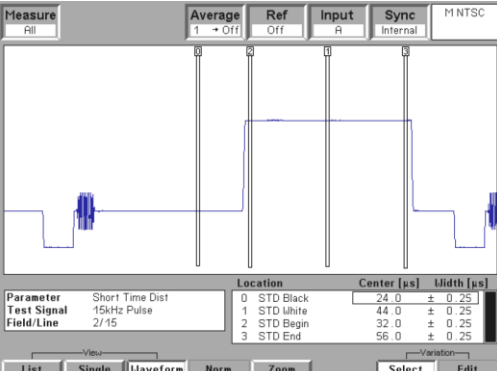
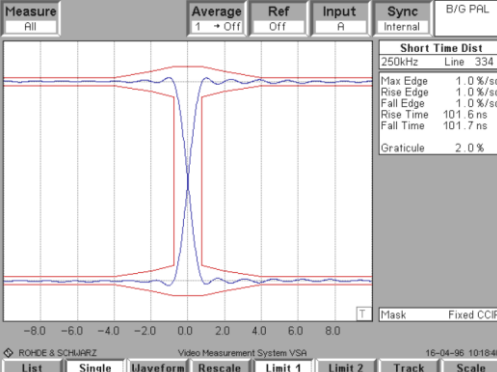
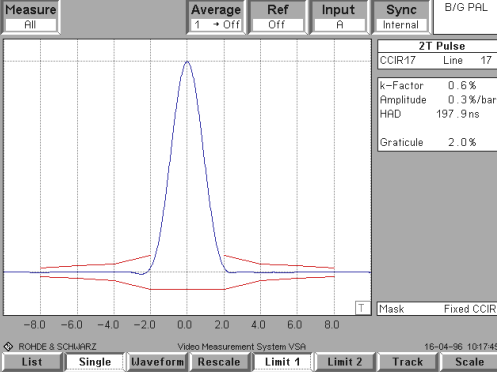
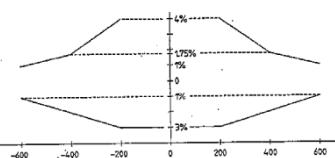
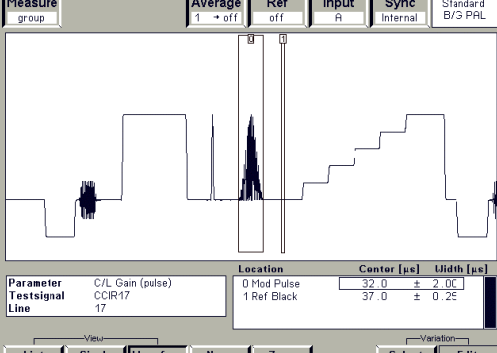
<p>Line time distortion</p>	<p>15 kHz rectangular pulse</p>		<ul style="list-style-type: none"> ■ 2% tilt referenced to the step amplitude 								
<p>Short time distortion</p>	<p>250 kHz rectangular pulse</p>		<table border="1" style="width: 100%; border-collapse: collapse;"> <thead> <tr> <th style="text-align: center;">Time / μs</th> <th style="text-align: center;">Limits / %</th> </tr> </thead> <tbody> <tr> <td style="text-align: center;">± 0.075</td> <td style="text-align: center;">± 7.5</td> </tr> <tr> <td style="text-align: center;">± 0.2</td> <td style="text-align: center;">± 5</td> </tr> <tr> <td style="text-align: center;">$\pm [0.4...1]$</td> <td style="text-align: center;">± 3</td> </tr> </tbody> </table>	Time / μ s	Limits / %	± 0.075	± 7.5	± 0.2	± 5	$\pm [0.4...1]$	± 3
Time / μ s	Limits / %										
± 0.075	± 7.5										
± 0.2	± 5										
$\pm [0.4...1]$	± 3										
<p>2T pulse amplitude / k factor</p>	<p>CCIR17</p>		<ul style="list-style-type: none"> ■ Pulse height $\pm 2\%$ compared to white bar ■ Baseline distortion within the tolerance mask: 								
<p>C/L gain / delay (pulse)</p>	<p>CCIR17</p>		<ul style="list-style-type: none"> ■ Gain $\pm 3\%$ ■ Delay ± 12 ns (± 20 ns) 								

Nonlinear distortion			
<p>Lum nonlinearity</p>	<p>CCIR330</p>		<p>Static and dynamic nonlinearity may not fall below 0.90</p>
<p>Differential phase</p>	<p>CCIR330</p>		<p>Modulation-dependent phase shift of the color subcarrier, max. $\pm 3^\circ$</p>
Periodic interference			
<p>HUM</p>	<p>Full field</p>		<p>Not less than 43 dB</p>

8.4 Measuring the audio parameters using an audio analyzer

When we need to assess the basic quality of the audio signal decoded in analog TV, we can use an audio analyzer such as the R&S®UP300. The main measurements are as follows:

- Signal/noise ratio:

This is defined as the ratio of the average power of the useful signal from the signal source to the average noise power of the interfering signal from the same signal source.

- Frequency response:

The frequency response characterizes the behavior of a linear time-invariant system. The output quantity is compared with the input quantity and plotted versus frequency.

- Total harmonic distortion (THD):

The THD is a measure of the distortion produced by nonlinearities. The THD indicates how pronounced the harmonics are that arise for distortion of a sinusoidal signal in comparison to the overall signal.

$$THD = \frac{\sum \text{harmonic_powers}}{\text{fundamental_frequency_power}}$$

8.4.1 Measurement principle



Depending on the audio measurements that are required, we must feed different test signals into the ATV exciter via the generator in the R&S®UP300:





- Total harmonic distortion and frequency response:

Sinusoidal signal at different frequencies (40 Hz, 100 Hz, 500 Hz, 1 kHz, 5 kHz, 10 kHz, 15 kHz).

- Noise voltage:

Measurement using a sinusoidal signal with $f = 500 \text{ Hz}$

8.4.2 Configuration of the generator function in the R&S®UP300

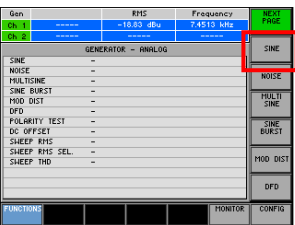
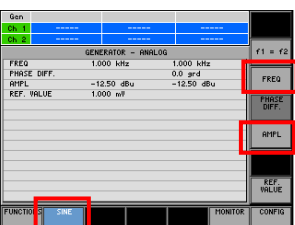
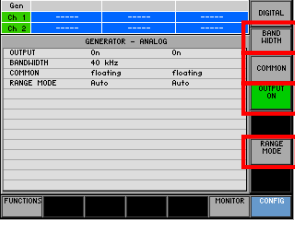
1. For the R&S®UP300's preset, please perform the following steps:
 - Press the "BACK SYS" key .
 - Using the cursor keys , select  from the bottom menu bar.
 - Press the "Preset" key .
2. To select the generator function in the R&S®UP300, press the "GEN" function button .
3. Select the sinusoidal signal to be generated using the "SINE" softkey.
 
4. Once you are in the "SINE" menu, you can use the "FREQ" and "AMPL" buttons to determine the frequency of the sinewave to be generated as well as its amplitude.
 
5. Configure the basic settings for the generator in the Config selection and switch the generator function to "active":
 

8.4.3 Performing audio measurements with the R&S®UP300

This section describes how to configure the analyzer in the R&S®UP300 and measure frequency response, THD, and S/N.

8.4.3.1 Basic settings for the R&S®UP300 analyzer

1. To select the generator function in the R&S®UP300, press the "ANL" function button .
2. In the "CONFIG" menu, you can set the basic configuration of the analyzer.









Anl				DIGITAL
Ch 1	----	----	----	BAND WIDTH
Ch 2	----	----	----	COMMON
ANALYZER - ANALOG				INPUT
INPUT	Gen Meas	Gen Meas		COUPLING
BANDWIDTH	22 kHz			RANGE MODE
COMMON	floating	floating		CHANNEL
COUPLING	AC			
RANGE MODE	Auto	Auto		
RANGE LIMITS	-	-		
CHANNEL	Ch 1&2			
FUNCTIONS				FILTER
				CONFIG

 - Bandwidth: Set this to 22 kHz since the frequency range of interest is between 40 Hz and 15 kHz.
 - Common: Grounded.
 - Coupling: AC.
 - Range Mode: Auto.
 - Channel: Ch 1.
3. Use the cursor keys to select the "FUNCTIONS" softkey. The window that appears will list the available measurements:

Anl				NEXT PAGE
Ch 1	----	----	----	FREQ. DC, RMS
Ch 2	----	----	----	PEAK
ANALYZER - ANALOG				QUASI PEAK
FREQ. DC, RMS	-			RMS SELECTIVE
PEAK VALUE	-			FFT
QUASI PEAK	-			THD
RMS SELECTIVE	-			
FFT	-			
THD	-			
POLARITY TEST	-			
DFD	-			
PHASE	-			
MOD. DIST	-			
PROTOCOL	-			
SAMPLE RATE	-			
FUNCTIONS				FILTER
				CONFIG

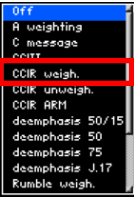
8.4.3.2 Weighted and unweighted noise measurement

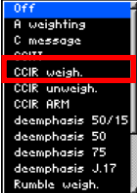
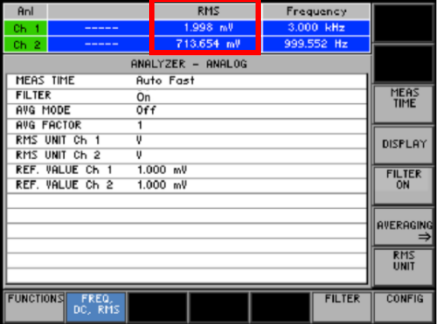
Two measurement steps are required to determine the level difference between the noise voltage (quasi-peak value) and useful voltage (RMS value). The level difference is then determined from the measured values. The measurement is performed both weighted in accordance with CCIR and unweighted.

1.	Select the "FREQ, DC, RMS" button  in the "FUNCTIONS" menu.
2.	If you select the "FILTER ON" key  , filtering is activated. You can configure it using the "FILTER" key  : <ul style="list-style-type: none"> ■ The deemphasis must also be activated in the Filter menu since the preemphasis is on. Select the "FILTER NO. 1" key  and choose "deemphasis 50":  ■ Depending on whether you are making a weighted or unweighted measurement, select the "FILTER NO. 2" key  and choose "CCIR weigh" (1k): 
3.	When you select the "FREQ, DC, RMS" function, you can specify the RMS measurement in greater detail.  <p>The RMS value for the measurement is used for further computation of the level difference.</p>
4.	In the "FUNCTIONS" menu, select the "QUASI PEAK" button  and deactivate the input signal on the generator side.

5. When you select the "QUASI PEAK" function, you can specify the QUASI PEAK measurement in greater detail.

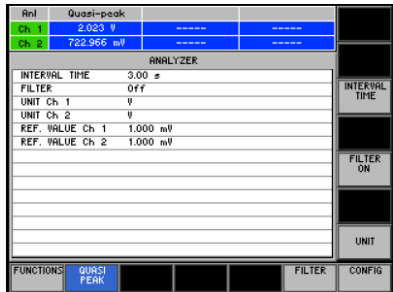

If you select the "FILTER ON" key , filtering will be activated. An interval time of 3.00 s represents the optimum value.
6. Depending on whether the levels are already specified as dB values, it may be necessary to perform a subtraction operation on the results or, alternatively, convert the decimal values into dB notation using the following formula:

$$R = 20 \cdot \log(S / N)$$

where S = useful voltage in volts
N = noise voltage in volts

Reference values:

The R&S[®] ETL outputs the demodulated audio signal on the two Lemo Triax connectors with a minimum weighted maximum S/N of 50 dB (intercarrier demodulation). This S/N value must always be verified (weighted).

8.4.3.3 Total harmonic distortion (THD) measurement

For the THD measurement, the preemphasis on the transmitter and the deemphasis on the analyzer must be switched off.

1. In the "FUNCTIONS" menu, select the "THD" button  .
2. When you select the "THD" function, you can specify the THD measurement in greater detail.

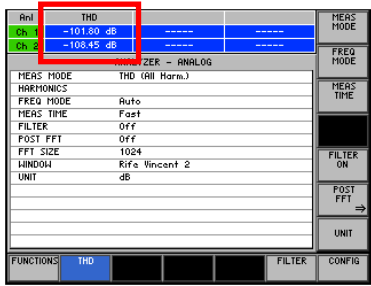

Keep the default settings.

Reference value:

The THD should be better than 46 dB.

8.4.3.4 Frequency response measurement

For the frequency response measurement, the preemphasis on the transmitter and the deemphasis on the analyzer must be switched off.

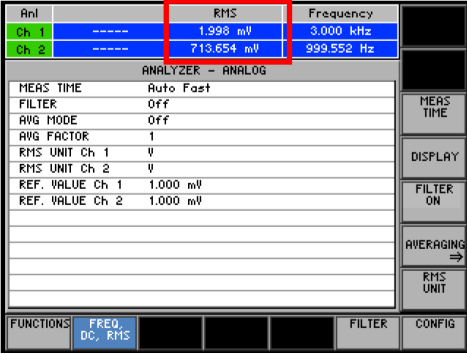
1.	Select the "FREQ, DC, RMS" button  in the "FUNCTIONS" menu.
2.	<p>When you select the "FREQ, DC, RMS" function, you can specify the RMS measurement in greater detail.</p>  <p>Keep the default settings and measure the RMS value of the input signal as a function of the generator frequency (40 Hz, 100 Hz, 500 Hz, 1 kHz, 5 kHz, 10 kHz, 15 kHz).</p>

Reference value:

The frequency response at the specified measurement points should be better than ± 0.5 dB. This corresponds to the maximum intrinsic error of the test instrument.

9 Abbreviations

BER	Bit error ratio
CCVS	Color composite video synchronous
COFDM	Coded orthogonal frequency division multiplexing
EVM	Error vector magnitude
MER	Modulation error ratio
OFDM	Orthogonal frequency division multiplex
THD	Total harmonic distortion
VSB	Vestigial sideband transmission

10 References

- [1] Fischer, Walter (2005). Digital Television. A Practical Guide for Engineers. Berlin: Springer.
- [2] Mäusl, Rudolf. Refresher topics – Television technology. Munich: Rohde & Schwarz.

11 Additional Information

Our Application Notes are regularly revised and updated. Check for any changes at <http://www.rohde-schwarz.com>.

Please send any comments or suggestions about this Application Note to Broadcasting-TM-Applications@rohde-schwarz.com.

12 Ordering Information

For DVB-T / DVB-H transmitter measurements see 7.1.

For ATV transmitter measurements see 8.2.

About Rohde & Schwarz

Rohde & Schwarz is an independent group of companies specializing in electronics. It is a leading supplier of solutions in the fields of test and measurement, broadcasting, radiomonitoring and radiolocation, as well as secure communications. Established more than 75 years ago, Rohde & Schwarz has a global presence and a dedicated service network in over 70 countries. Company headquarters are in Munich, Germany.

Regional contact

Europe, Africa, Middle East
+49 89 4129 12345
customersupport@rohde-schwarz.com

North America
1-888-TEST-RSA (1-888-837-8772)
customer.support@rsa.rohde-schwarz.com

Latin America
+1-410-910-7988
customersupport.la@rohde-schwarz.com

Asia/Pacific
+65 65 13 04 88
customersupport.asia@rohde-schwarz.com

China
+86-800-810-8228 /+86-400-650-5896
customersupport.china@rohde-schwarz.com

Environmental commitment

- Energy-efficient products
- Continuous improvement in environmental sustainability
- ISO 14001-certified environmental management system



This application note and the supplied programs may only be used subject to the conditions of use set forth in the download area of the Rohde & Schwarz website.

R&S® is a registered trademark of Rohde & Schwarz GmbH & Co. KG;
Trade names are trademarks of the owners.