

## ***APPLICATION NOTE***

# **Audio-to-Video Delay Measurement**

### *Products:*

***CCVS + COMPONENT GENERATOR***

***CCVS GENERATOR***

***AUDIO ANALYZER***

***R&S SAF***

***R&S SFF***

***R&S UPL***

# Audio-to-Video Delay Measurement

## Contents

1	Introduction .....	3
2	Measurement Setup and Compensation for its Audio-to-Video Delay .....	3
2.1	Compensating for UPL Delay	
2.2	Compensating for Setup Delay .....	3
3	Measurement of Audio-to-Video Delay on a DUT .....	4
4	Summary .....	5
5	Additional Information .....	5
6	Ordering Information .....	6

## 1 Introduction

A lack of lip synchronicity is an effect that can severely impair the quality of TV reception. With modern digital signal processing, this audio-to-video delay occurs much more often than in earlier times when analog signal generation was used. The total delay can reach several hundred milliseconds, which is immediately noticeable on a TV home receiver. To prevent such impairments, the audio-to-video delay must be measured.

## 2 Measurement Setup and Compensation for its Audio-to-Video Delay

Because modern signal processing is digital, both video and audio signals should be processed in the digital domain. Video needs to adhere to the ITU-R BT. 601/656 standard, while audio should comply with the AES/EBU specifications. Since special signals are required when determining the timing of lip synchronicity, measurement is performed "off line". Thus, you need to use a video generator such as the CCVS Generator R&S SFF (or R&S SAF), which optionally has a 270-Mbit/s SDI (serial digital interface) output, and an audio generator with an AES/EBU-compliant digital output, which is part of the Audio Analyzer R&S UPL.

When equipped with the R&S UPL-B10 option, the R&S UPL uses its internal PC to create a trigger pulse that functions as a timing reference for the measurements. A small Basic program switches pin number 2 of the R&S UPL parallel interface located on the rear panel synchronously to the start of the digital audio burst output:

```
10 REM  UPL OUTPUTS DIGITAL SINE BURST
      AND SYNCHRONOUS TRIGGER PULSE
20 UPL OUT "INIT:CONT OFF"
30 REM  UPL SENDS SINE BURST
40 OUT 632,1: OUT 632,0
50 REM  CREATING THE TRIGGER PULSE
      ON PARALLEL PORT PIN 2 IS SWITCHED TTL
      HIGH AND BACK TO TTL LOW
60 HOLD 500
70 REM  WAIT 500 MS
80 GOTO 20
90 REM  ENDLESS LOOP
```

This small Basic program enables you to measure an audio-to-video delay of up to 500 ms. If you need a larger time interval, you simply have to increase the value for HOLD.

## 2.1 Compensating for R&S UPL Delay

To make delay compensation easier to understand, the procedure is divided into two steps, described in this and the following sections.

The first step is to compensate for the R&S UPL delay. Because of a delay between the audio sine burst and the trigger pulse, a R&S UPL BurstOnDelay of about 2 ms is inserted. The STATUS menu shows the required R&S UPL settings:

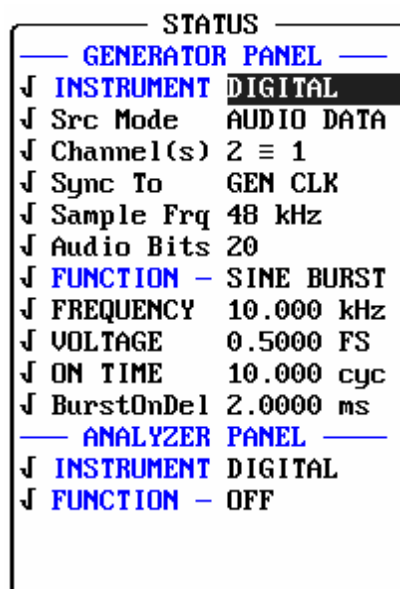

Fig 1 Settings in R&S UPL.

This BurstOnDelay eliminates all delay between the trigger pulse and the digital sine burst caused by program processing. Even more precise compensation can be achieved by adjusting this value by means of an oscilloscope. To perform this adjustment, you have to change the digital generator in the R&S UPL to an analog generator with identical function settings. The analog signal output of the R&S UPL has an additional delay of 690  $\mu$ s compared to the digital output; thus, you can use the analog output to determine the time offset between the digital sine wave burst and the trigger pulse. You will need to adjust the BurstOnDelay in the analog domain and then add 690  $\mu$ s to the determined BurstOnDelay after switching

back to the digital generator. For example, a BurstOnDelay of 1.4 ms in the analog generator yields a BurstOnDelay of 2.09 ms when using the digital generator.

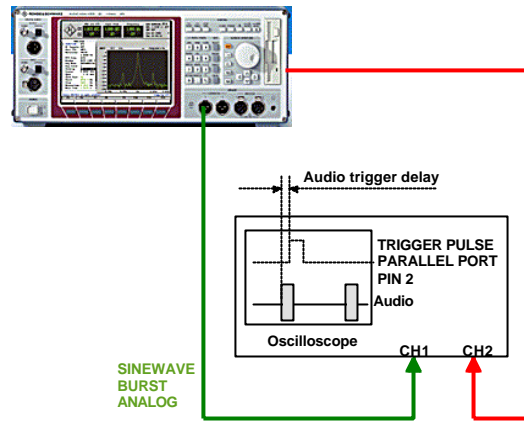

Fig 2 R&S UPL time offset between trigger pulse and sine burst without compensation.

## 2.2 Compensating for Setup Delay

The second step is to compensate for the delay between between the R&S UPL and the R&S SFF/SAF.

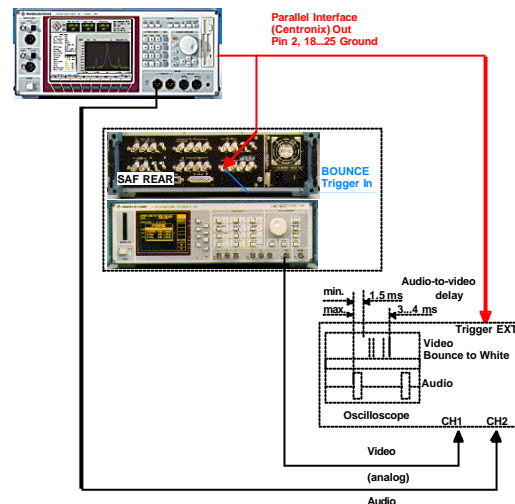

Fig 3 Compensating for overall delay.

The R&S UPL outputs both the AES/EBU data stream and the trigger pulse from pin number 2 of the parallel interface, which triggers the BOUNCE signal of the R&S SFF/SAF and the oscilloscope in EXT trigger mode. The BOUNCE TRIGGER is switched to EXT in the APL/BOUNCE menu of the R&S SFF/SAF.

If the trigger pulse occurs, the BOUNCE signal jumps from a first settable luminance level to a second settable luminance level. Nominally, these levels will be black and white. This transition marks the delay of the video signal with reference to the trigger pulse.

The R&S UPL bounce trigger pulse is processed by the R&S SFF/SAF firmware. Therefore, the response delay that is encountered until the bounce signal changes the polarity is not constant. The basic delay is approximately 1.5 ms, although this figure can randomly increase to 3 to 4 ms. For exact measurements, only the smallest delay visible on the oscilloscope screen should be taken into account. This additional delay is also compensated for by using the R&S UPL BurstOnDelay. Thus, you can measure not only the audio-to-video delay but also the absolute delay caused by signal processing within the DUT.

Delay compensation that meets an overall accuracy of less than 1 ms should be more than sufficient because the human eye and ear cannot detect a timing difference of less than approximately 10 ms between video and audio. If you use the above setup and trim the R&S UPL BurstOnDelay, the offset will certainly not exceed a few hundred microseconds in duration.

### 3 Measurement of Audio-to-Video Delay on a DUT

Figure 4 shows the setup for the proposed audio-to-video delay measurement.

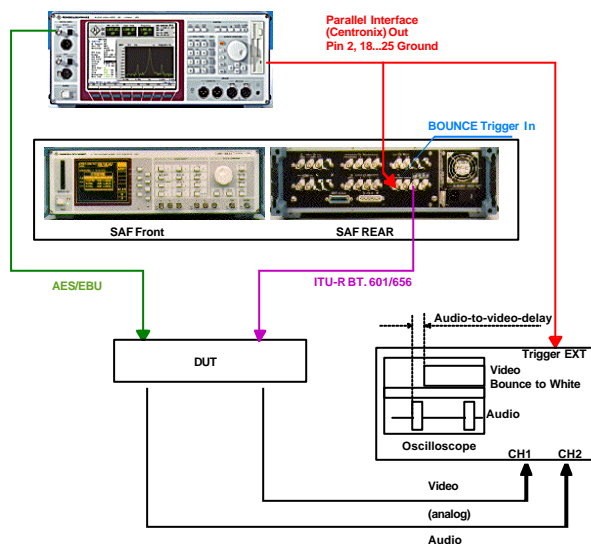

Fig 4 Measurement setup for audio-to-video delay.

Figure 5 presents a typical scenario within a playout center showing possible DUTs. A DUT can be any of the processing steps or any of the units in the transmission chain from the camera and

microphone to the screen and loudspeaker of the home receiver that can cause delays between video and audio. In the simplest case, the DUT is an MPEG2 encoder.

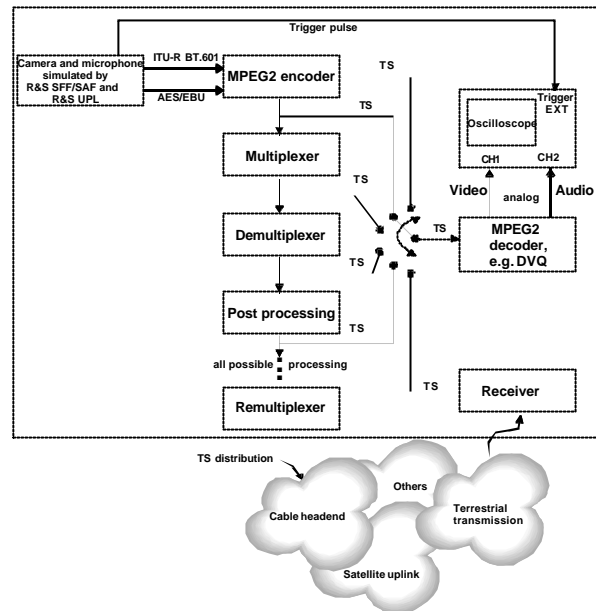

Fig 5 The audio-to-video delay measurement scenario.

The Digital Video Quality Analyzer R&S DVQ should be used as the reference MPEG2 decoder; it has a typical audio-to-video delay of 9 ms. This delay can also be compensated for by means of the R&S UPL BurstOnDelay. The measured delay on the oscilloscope screen will then be the true audio-to-video delay of the DUT.

The only constraint is that the trigger pulse must be available at the measurement site although the distance between the trigger pulse source and the oscilloscope may exceed 100 meters. The cable delay is insignificant, and the amplitude-versus-frequency response can be corrected by using a cable equalizer.

The external bounce trigger can be problematic: If you measure the bounce transition with a field-frequent video signal, the change in BOUNCE level is sometimes masked by the vertical blanking interval because the trigger pulse is not synchronized to the field frequency. You have to wait until the blanking interval has shifted across the bounce trigger point and the black-to-white or white-to-black transition is again visible. To avoid this, you can also use an H-frequent video signal for measurement.

## 6 Ordering Information

Audio Analyzer R&S UPL	1078.2008.06
Option R&S UPL-B10	1078.3904.02
CCVS Generator R&S SFF	2007.1057.02
Digital Video Interface SFF-Z1	2007.1063.03
CCVS+Component Generator	R&S SAF
	2007.1005.02
Digital Video Interface R&S SAF - Z1	2007.1063.02

The oscilloscope display will then be as follows:

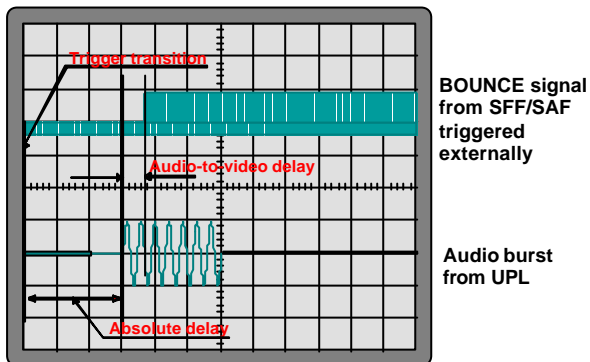

Fig 6 Oscilloscope display for measurement of absolute delay and audio-to-video delay.

## 4 Summary

You can measure lip synchronicity by using two units: the Audio Analyzer R&S UPL with the R&S UPL-B10 option and the CCVS Generator R&S SFF (or R&S SAF) with the Digital Video Interface R&S SFF-Z1 (R&S SAF-Z1) option, plus a simple, commercially available oscilloscope. The absolute accuracy of the audio-to-video delay measurement is better than 1 to 2 ms, which is sufficient since the human ear and eye cannot detect delays of less than approximately 10 ms.

## 5 Additional Information

Our Application Notes are regularly revised and updated. Check for any changes at <http://www.rohde-schwarz.com>.

Please send any comments or suggestions about this Application Note to:

[Broadcasting-TM-Applications@rohde-schwarz.com](mailto:Broadcasting-TM-Applications@rohde-schwarz.com).