

Group Delay and Phase Measurement on Frequency Converters

Application Note

Products:

R&S® ZVA8	R&S® ZVA50
R&S® ZVA24	R&S® ZVT8
R&S® ZVA40	R&S® ZVT20

Frequency converters e.g. in satellite transponders need to be characterized not only in terms of amplitude transmission but also in terms of phase transmission or group delay, especially with the transition to digital modulation schemes. They often do not provide access to the internal local oscillators. This application note describes a method using the R&S ZVA to measure group delay of mixers and frequency converters with an embedded local oscillator very accurately. The key aspect of this new technique is, that the network analyzer applies a 2-tone signal to the frequency converter. By measuring the phase differences between the two signals at the input and at the output, it calculates group delay and relative phase between output and input.

Table of Contents

1	Abstract	3
2	Theoretical Background.....	3
3	The Two-Tone Method.....	6
3.1	Test Setup.....	7
3.1.1	The hardware setup.....	8
3.2	The instrument settings	9
3.2.1	Find optimum settings for low trace noise	12
3.2.1.1	Increase the power level of Source 1	12
3.2.1.2	Apply averaging	13
3.2.1.3	Increase the aperture	13
3.2.1.4	Increase number of points and apply smoothing	14
3.3	Calibration	15
4	Test Results	17
4.1	Comparing the Two Tone Technique with S-Parameter technique.....	17
4.1.1	Measurement of a filter	17
4.1.2	Measurement of a cable	17
4.2	Measurement of a converter.....	18
5	Appendix	19
5.1	Alternative setups for lower frequencies	19
5.1.1	Setup for input frequencies lower than 700 MHz with ZVA24, ZVA40 or ZVA50 (up-conversion).....	19
5.1.2	Setup for output frequencies lower than 700 MHz with ZVA24, ZVA40 or ZVA50 (down conversion).....	21
5.2	Searching for the correct LO frequency.....	22
6	Ordering Information.....	23

1 Abstract

Mixers are one of the fundamental components of many receivers or transmitters especially in the microwave range. Any mixer-based receiving or transmit system requires that the mixers have well-controlled amplitude, phase and group-delay responses. Especially phase- and group-delay linearity are essential for low bit error rates of data transmission or high target resolution for phased antenna array modules of surveillance systems.

A key measurement is the relative and/or absolute group delay for frequency converters.

Relative phase and **group delay** can be measured using the so-called reference or golden mixer technique, as long as the local oscillator is accessible.

However, due to increasing integration and miniaturization often neither the local oscillator (LO) nor a common reference frequency signal are accessible.

This application note describes a new technique for measurements on frequency converters with an embedded LO source and without direct access to a common reference signal. Key for this new technique is, that the network analyzer stimulates the device under test with a two tone signal. By measuring the phase differences between the two signals at the input and the output the network analyzer calculates the phase transfer function or the group delay of the device under test..

The measurement accuracy does not depend on the embedded LO's frequency stability as long as the deviation is within the measurement bandwidth of the network analyzer receivers.

2 Theoretical Background

Group delay measurements are based on phase measurements. The measurement procedure corresponds to the definition of group delay τ_{gr} as the negative derivative of the phase φ (in degrees) with respect to frequency f :

$$\tau_{gr} = -\frac{1}{360^\circ} \cdot \frac{d\varphi}{df}$$

For practical reasons, Vector Network Analyzers measure a difference coefficient of the transmission parameter S21 instead of the differential coefficient, which yields a good approximation to the wanted group delay τ_{gr} , if the variation of phase φ is not too nonlinear in the observed frequency range Δf , which is called the aperture.

$$\tau_{gr} \approx -\frac{1}{360^\circ} \cdot \frac{\Delta\varphi}{\Delta f}$$

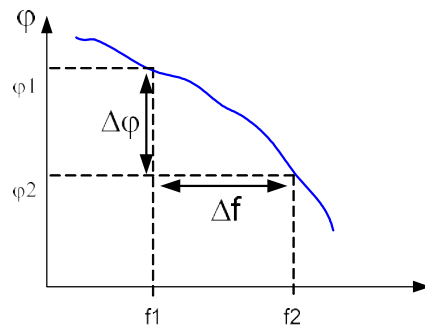

Fig. 1 Definition of phase shift $\Delta\varphi = \varphi_2 - \varphi_1$ and aperture $\Delta f = f_2 - f_1$.

Fig. 1 shows the terms $\Delta\varphi = \varphi_2 - \varphi_1$ and $\Delta f = f_2 - f_1$ for linearly decreasing phase response, e.g. of a delay line.

For non frequency converting devices the measurements of S21 at two different frequencies can happen sequentially. This works fine for non frequency converting DUTs as filters and amplifiers.

With frequency converting devices like mixers, the phase between the input and output signal cannot be measured directly, because the frequencies are different. Also the phase is not only influenced by the component itself, but also by the phase of the local oscillator.

Therefore, phase and group delay measurements on mixers used so-called reference mixer technique. The reference mixer uses the same local oscillator as the device under test to reconvert either the RF or IF signal in order to get identical frequencies at the reference and measurement receiver of the VNA. This technique also helps to get rid of phase instabilities of the local oscillator.

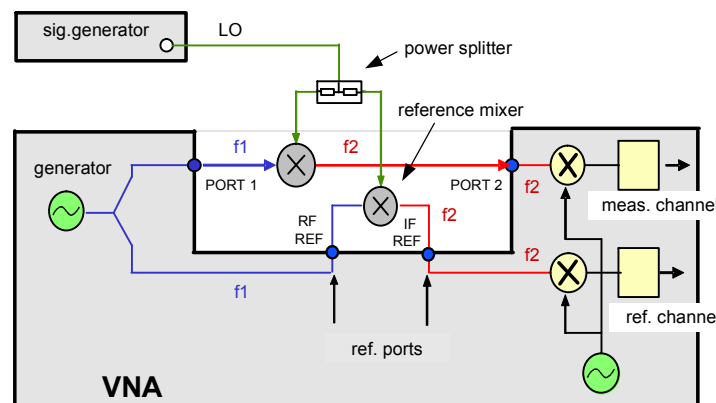

This measurement delivers phase and group delay relative to a golden mixer, that was measured for calibration instead of the mixer under test (MUT). Normally, the golden mixer is assumed to be ideal, so that the measurement result of the MUT shows the phase and group delay difference in respect of this golden mixer.

If the LO of the device under test is not accessible, group delay measurements are not possible with a reference mixer, but use AM or FM modulated signals. Other methods try to reconstruct the LO. They use an external signal generator as LO for the reference mixer and try to tune the generator frequency until the phase drift versus time of the IF is minimized.

These techniques have limitations in terms of dynamic range measurement accuracy and speed. In addition internal local oscillators of the device under test often are not very stable, which makes it hard for the external generator to follow.

The R&S ZVA uses a different approach, that overcomes the problems of the former techniques.

3 The Two-Tone Method

This new method offered with option ZVA-K9 uses a two tone signal, that is sent to the device under test.

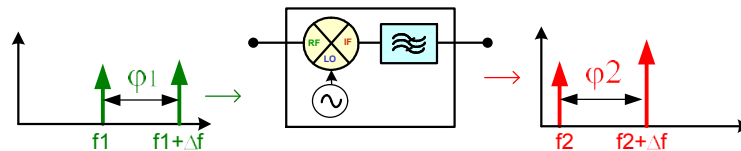

The R&S ZVA measures the phase differences between both carriers at the input and the output of the device under test. Then, the group delay is calculated as :

$$\tau = \frac{-1}{360^\circ} \cdot \frac{\Delta\varphi}{\Delta f} \quad \text{with } \Delta\varphi = \varphi_2 - \varphi_1;$$

The frequency difference Δf between both carriers is called the aperture.

To measure the phase difference of two carriers the R&S ZVA provides for each analogue receiver channel two digital receivers that measure both signals simultaneously.

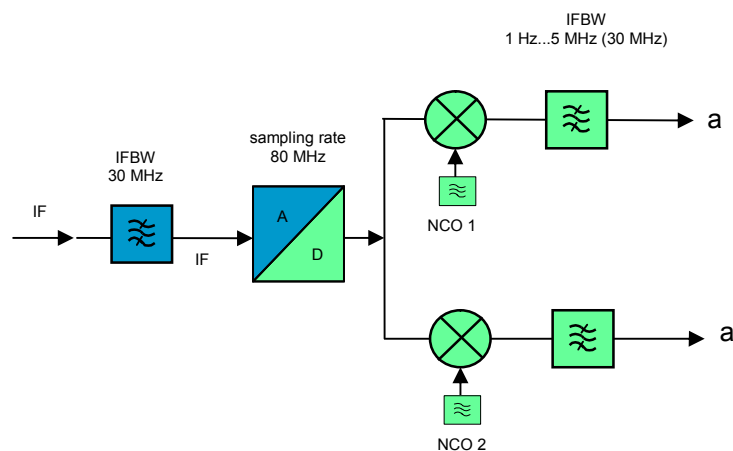

This technique works also in case of a frequency converting DUT, because frequency and phase instabilities of the DUT's LO are cancelled out, when calculating $\Delta\varphi$.

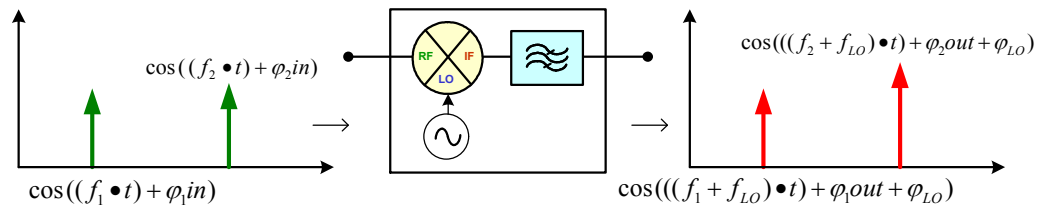

$$\Delta\varphi = (\varphi_{2out} + \varphi_{LO} - \varphi_{1out} - \varphi_{LO}) - (\varphi_{2in} - \varphi_{1in})$$

Besides group delay, the R&S ZVA also calculates the relative phase of the DUT by integration of the group delay as well as the dispersion by differentiation of the group delay. Using a mixer with known group delay for calibration, provides absolute group delay. If only relative group delay is necessary, a golden **mixer** is sufficient for calibration.

3.1 Test Setup

The following accessories are required:

Vector Network Analyzer

Direct Generator / Receiver Access
Frequency Conversion

Embedded LO Mixer Delay Measurement
Cable Set for ZVA-K9 (recommended)

ZVA 4-port or
ZVT with at least 3 ports
ZVA-B16
ZVA-K4
ZVA-K9
ZVA-B9

This example measures a converter with the following settings:

Swept RF and IF, fixed LO, IF=RF-LO

RF frequency: 5.37 GHz to 5.47 GHz
LO frequency: 4.5 GHz
IF frequency: 870 MHz to 970 MHz

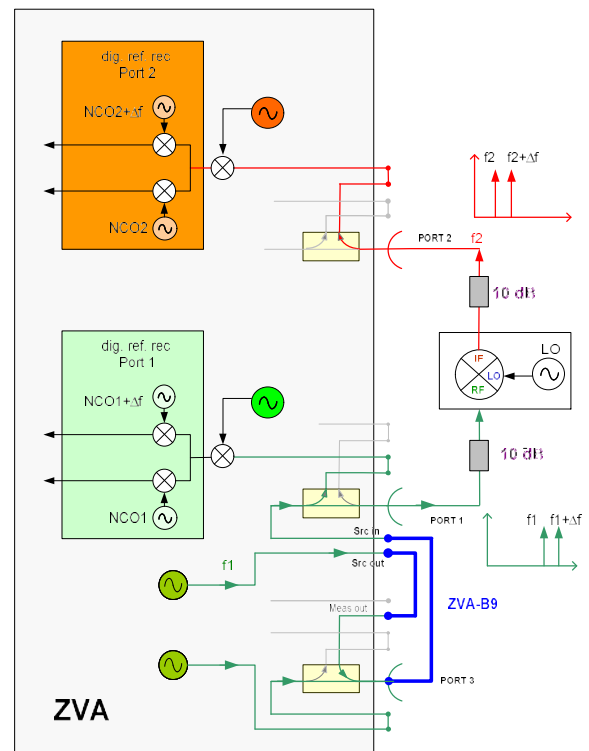

3.1.1 The hardware setup

For accurate measurements, it is necessary to generate a two tone signal with an accurate and stable frequency offset. The R&S ZVA can provide this signal by using both sources of a 4-port model.

The two tone signal is generated by using an external combiner or using one of the ZVA's internal couplers as combiner.

For that purpose perform the following connections:

Src out (Port 1) -> Meas out (Port 2)

Port 2 -> Src in (Port 1)

Rohde & Schwarz offers with the ZVA-B9 a cable set for the different types of ZVA (see order information).

Thus the two tone signal runs via the reference receiver of Port 1 to the input of the DUT.

This setup is recommended for all ZVA models, as long as IF and RF frequencies are above 700 MHz. If a microwave ZVA as ZVA24, ZVA40 or ZVA50 is used, the attenuation at low frequencies of the internal coupler may lead to an increased trace noise. If this is too high, alternative setups are recommended as indicated in the appendix.

To increase the accuracy, well matched 6 dB to 10 dB attenuators are recommended at both ports directly in the measurement plane.

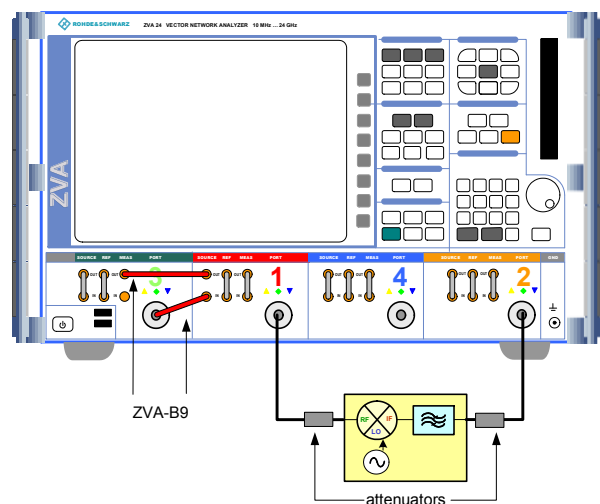

Setup using ZVA-B9

3.2 The instrument settings

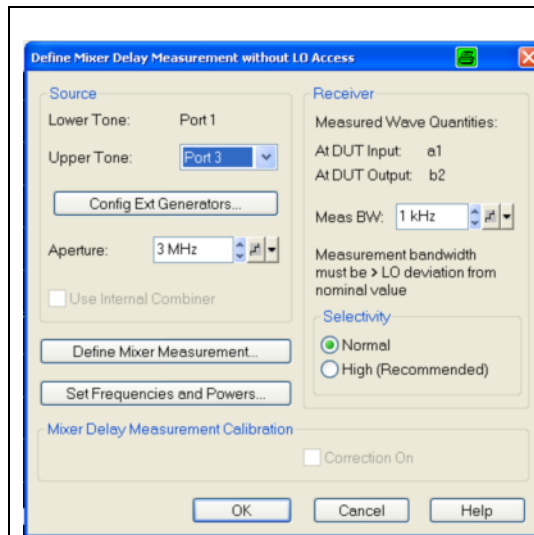

Configure the mixer measurement.

Press **MODE** - MIXER DELAY MEAS - "DEFINE MIXER DELAY MEAS.."

Press "Define Mixer Measurement"

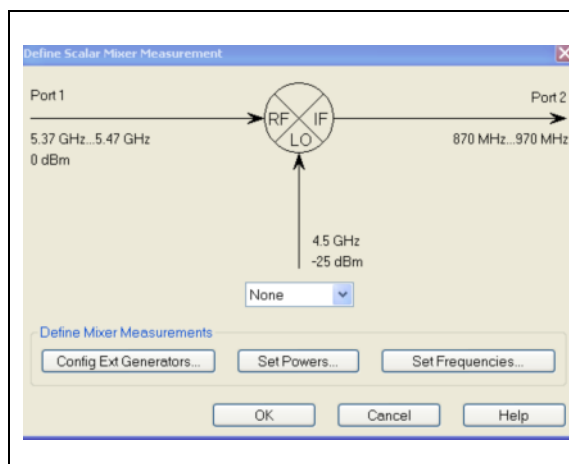

Select the LO source

Because the LO of the DUT is internal, "NONE" is selected

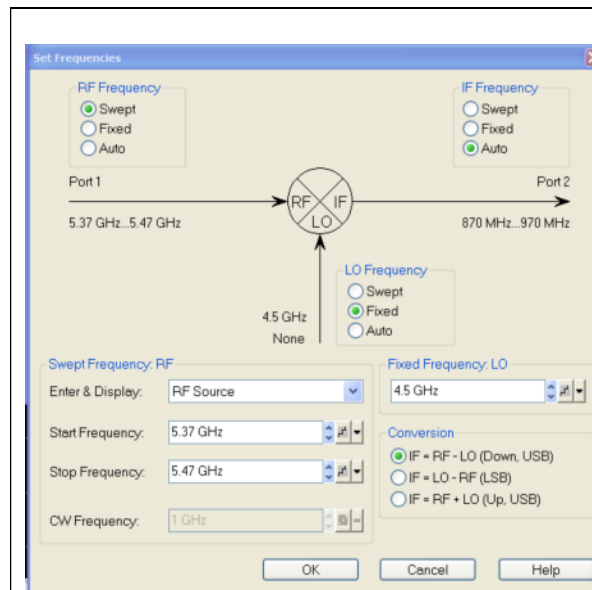

Configure the frequencies and conversion type.

Press “Set Frequencies” in the scalar mixer measurement dialog.

RF frequency: Swept
 LO frequency : Fixed
 IF frequency: Auto

Fixed Frequency LO: 4.5 GHz
 Swept frequency:
 Start 5.37 GHz

Stop 5.47 GHz

Conversion:
 IF=RF-LO

Press “OK”

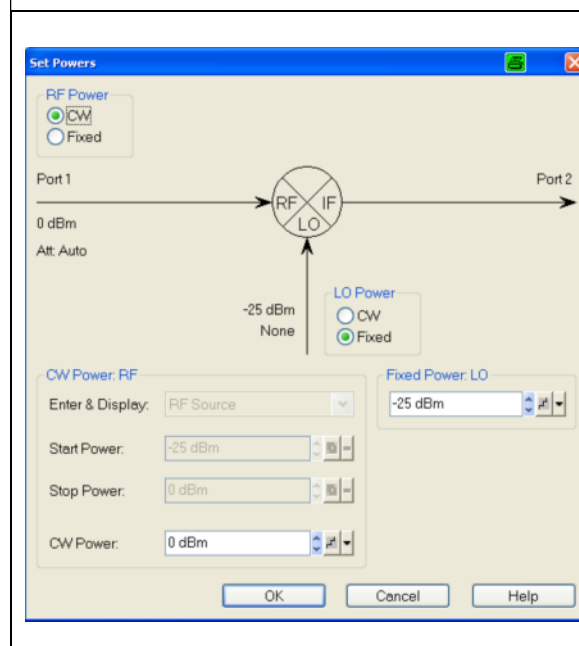

Set the power levels:

Press “Set Powers” in the scalar mixer measurement dialog.

CW Power: 0 dBm

The DUT should be measured with -10 dBm. Because 10 dB attenuators are applied to the ports, 0 dBm is selected.

Press “OK” two times to close the Set Power and the Define Mixer Measurement.. dialog

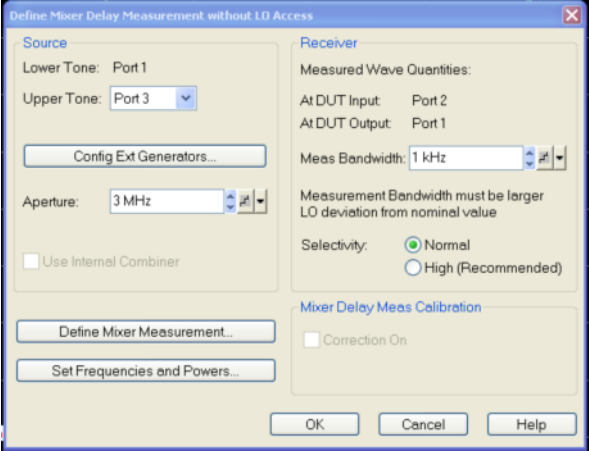

Configure the settings for the group delay measurement

Upper Tone: Port 3
Aperture: 3 MHz
Meas Bandwidth: 1 kHz
Selectivity: Normal

External generators can be used as well, but are not recommended, because frequency and phase stability are very critical.

The selected aperture is 3 MHz. It means that the frequency offset Δf between both carriers is 3 MHz. The aperture for the mixer group delay measurement can be changed in this dialog, only, not in the format menu.

The measurement bandwidth should be as wide as the embedded LO's frequency stability or deviation. Normal selectivity is sufficient, as long as the aperture is about 50 times wider than the measurement bandwidth. If the aperture is very small, selective filters have to be used.

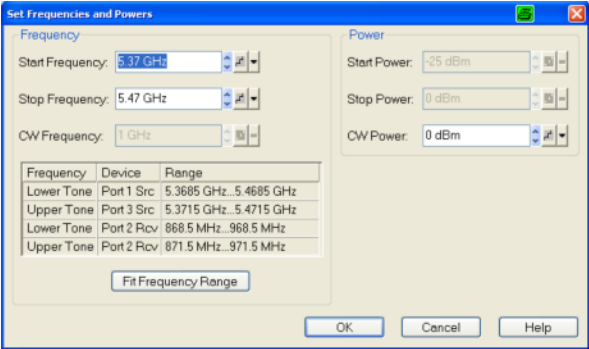

Press Set frequencies and Powers in the “Mixer Delay Measurement...” dialog.

Normally all settings are already done in the previous dialogs, but can be checked again.

If the settings exceed the frequency range of the ZVA, “Fit Frequency Range” will adjust it automatically

Press “OK”

Now you are back in the Mixer Delay Measurement dialog.

Press “OK” to activate the mixer group delay, The measurement parameter of the active trace is switched to group delay automatically.

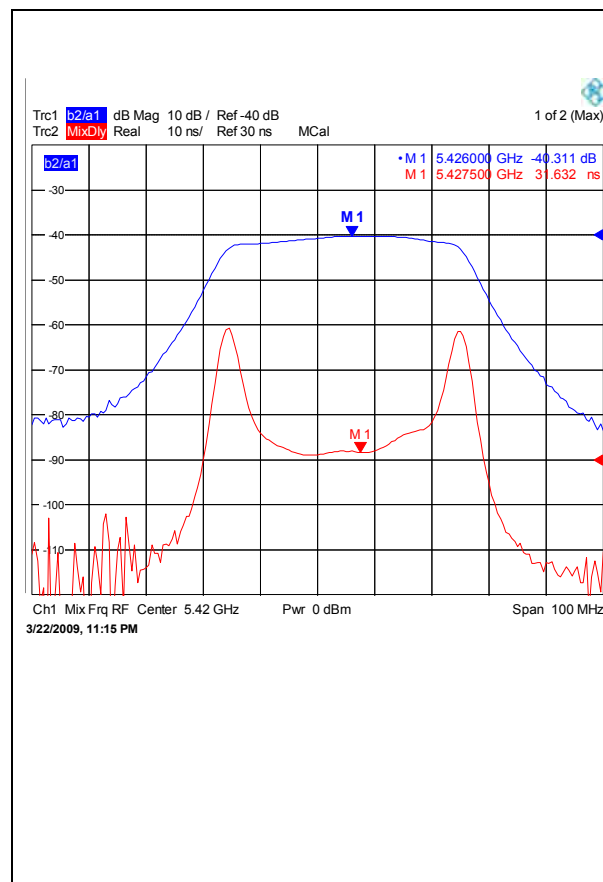

It is recommended to measure conversion loss first, to check if the settings especially the frequency of the embedded LO is correct.

Mixer group delay and conversion loss can be measured in the same channel so simply add a trace for the conversion loss.

Press:

TRACE SELECT – ADD
TRACE
MEAS – RATIOS – b2/a1 Src
Port1

If the trace is noisy or the magnitude of the conversion loss changes when reducing the measurement bandwidth, the LO frequency of the DUT is different to the settings of the ZVA.

3.2.1 Find optimum settings for low trace noise

The settings used above should produce (loss of DUT 6 dB) a group delay deviation (that looks as trace noise) of 100 ps pk-pk. If the DUT has a higher loss and thus higher trace noise the following steps can help to reduce the noise.

3.2.1.1 Increase the power level of Source 1

Using the cable set ZVA-B9 the source of port 1 is injected into the coupler or bridge of Port 2 via Meas Out. Due to the loss of the coupler or bridge, it is reduced by this attenuation. The attenuation is about 10 dB. (The coupler of the microwave ZVAs has 10 dB attenuation above 700 MHz and more for lower frequencies). That means, that the power of the carrier from source 1 is about 10 dB lower than the carrier from source 2. Increasing the power of source 1 will improve the trace noise. This can be done in the port configuration.

	<p>Press:</p> <p>MODE – Port Config... Pb... (from Port 1)</p> <p>The dialog to configure the power of port 1 pos up.</p>
	<p>Add 20 dB for ZVA8 and 10 dB for the other ZVA models in “Port Power Offset”</p> <p>The power of source 1 is now always 10 dB higher than the power of source 2</p> <p>Press “OK”</p>

3.2.1.2 Apply averaging

Reducing the IF bandwidth might help, but can lead to worse results if the embedded LO is unstable. Applying averaging improves the trace noise without reducing the bandwidth.

3.2.1.3 Increase the aperture

Increasing the aperture will also improve the trace noise. But there are limitations. Increasing the aperture, increases also the phase difference of the two tones. This phase difference should not exceed 180° otherwise the result is incorrect.

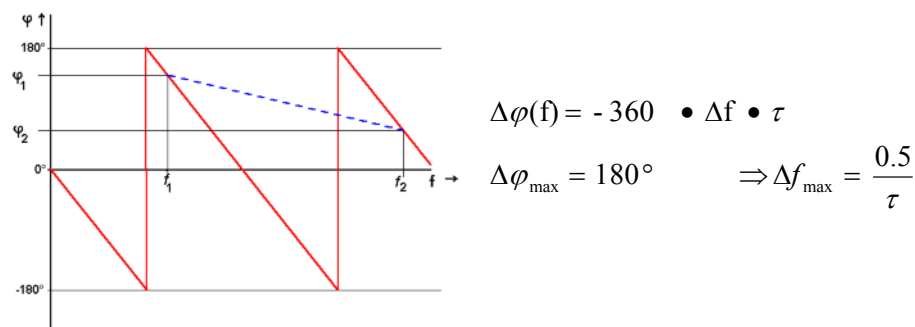

The higher the group delay, the lower the maximum aperture. A DUT with 100 ns limits the maximum aperture to 5 MHz. You find information how to select a suitable aperture in the App.-Note. 1EZ 35 “Group and Phase Delay Measurements with Vector Network Analyzer ZVR”.

3.2.1.4 Increase number of points and apply smoothing

Increasing the aperture is not only limited by the group delay of the DUT, but will also hide information, especially if the group delay of the DUT changes versus frequency. Smoothing together with increasing the number of points improves the trace noise furthermore without losing information. Smoothing can sometimes improve the trace noise more than applying averaging.

Example:

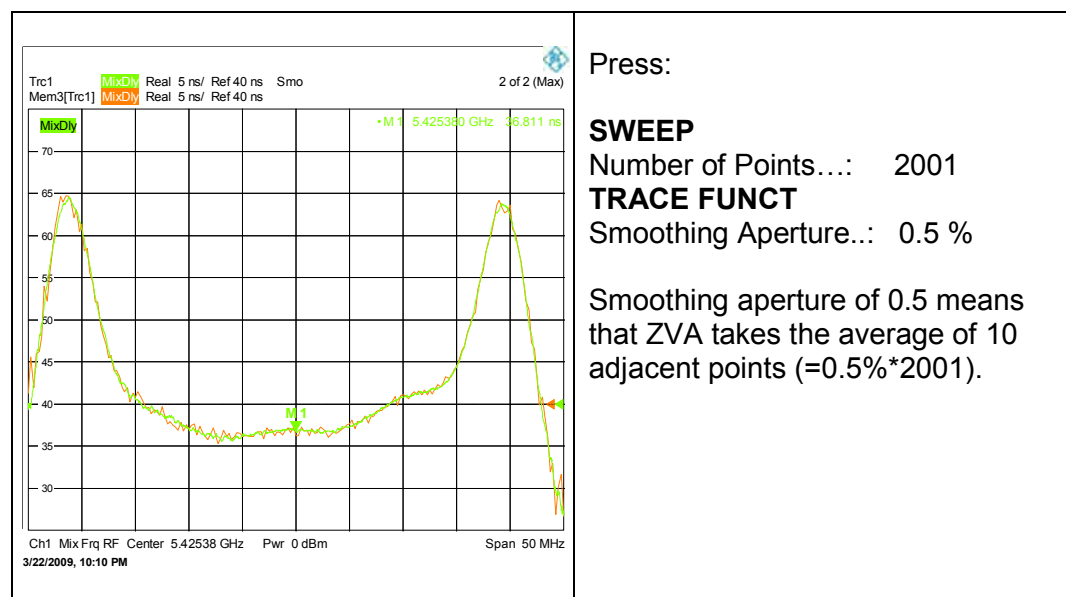

3.3 Calibration

The calibration is done with an ideal or known calibration mixer. To get a known calibration mixer, it can be characterized with ZVA-K5 before. ZVA-K5 is an option to measure vector error corrected absolute phase and group delay of mixers.

Often absolute group delay is not required, but only relative group delay and group delay ripple. In these cases it is sufficient to use a “golden mixer” with linear phase and flat group delay for calibration.

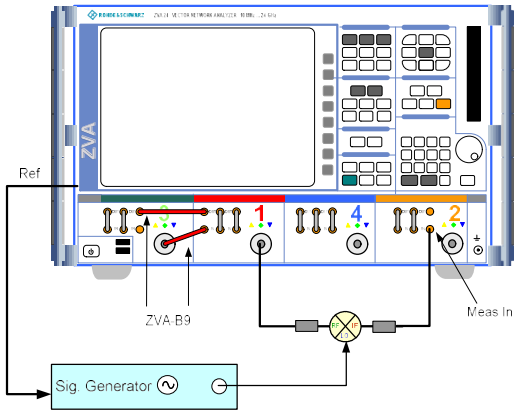
	<p>Select a suitable aperture for the measurement before starting the calibration. Changing the aperture between calibration and decreases the measurement accuracy.</p> <p>Connect the golden or calibration mixer instead of the DUT.</p> <p>Use an external signal generator as LO. Set the frequency and the power level. Lock the reference frequencies of the LO to the ZVA so that narrow bandwidths can be used.</p> <p>To lock the ZVA to the sig. gen connect a suitable cable and press:</p> <p>System Config - External Reference PWR BW AVG Meas Bandwidth:-100 Hz</p> <p>AVERAGE FACTOR: 10 AVERAGE ON</p>
	<p>Press: MODE - MIXER DELAY MEAS – CAL MIXER DELAY MEAS...</p> <p>The calibration dialog pops up.</p>

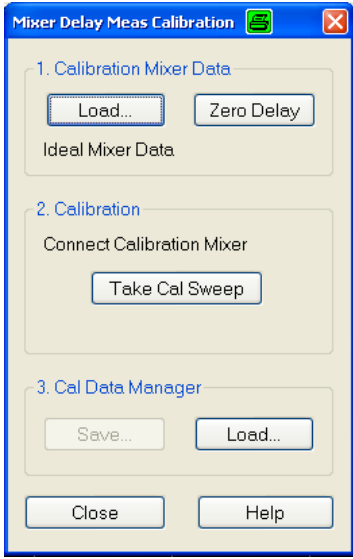
	<p>For absolute group delay, the data of the calibration mixer have to be loaded using the button “Load”</p> <p>For relative group delay, a data set with 0 s of delay is loaded, using the button “Zero Delay”</p> <p>Press: Take Cal Sweep</p> <p>Wait until the message “finished” appears and close the dialog.</p> <p>If necessary, the calibration data can be saved and recalled using the “save” and “Load” button.</p>												
<p>Trc1 MixDly Real 100 ps/ Ref 0 s MCal</p> <table border="1" data-bbox="405 1115 938 1263"> <tr> <td>MixDly</td> <td></td> <td></td> <td></td> <td></td> <td></td> </tr> <tr> <td>400</td> <td></td> <td></td> <td></td> <td></td> <td></td> </tr> </table>	MixDly						400						<p>MCAL In the trace line shows that the trace is calibrated</p>
MixDly													
400													

4 Test Results

4.1 Comparing the Two Tone Technique with S-Parameter technique

4.1.1 Measurement of a filter

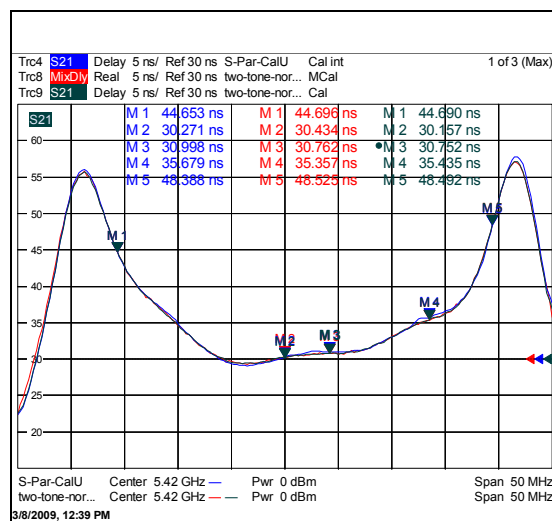

Blue:
Full two port calibrated S-parameter technique

Red:
Normalized two tone technique

Green:
Normalized S-parameter technique

4.1.2 Measurement of a cable

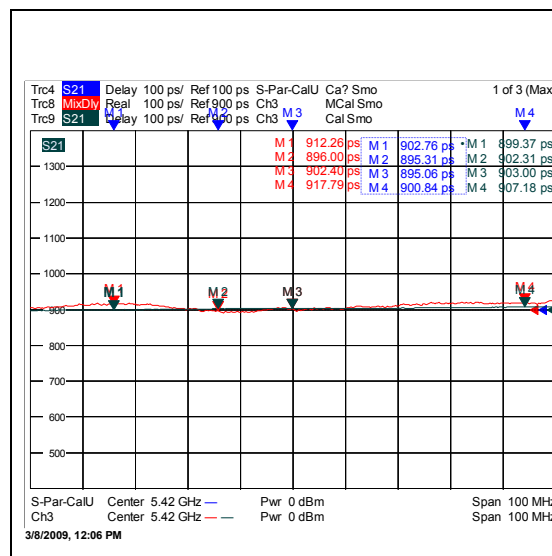

Green:
Normalized S-parameter meas

Red:
Normalized two tone technique

Blue:
Full two port calibrated S-parameters

4.2 Measurement of a converter

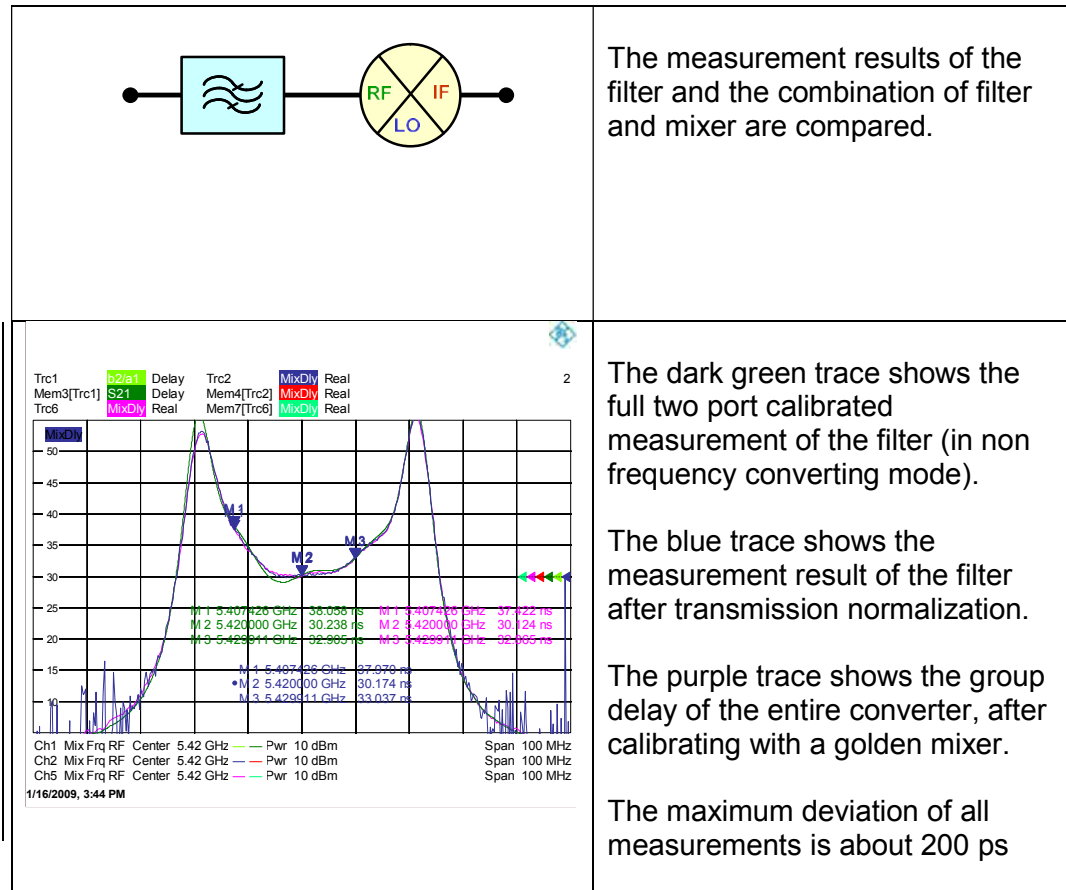

5 Appendix

5.1 Alternative setups for lower frequencies

Loss of the coupler of the microwave instruments ZVA24, ZVA40 and ZVA50

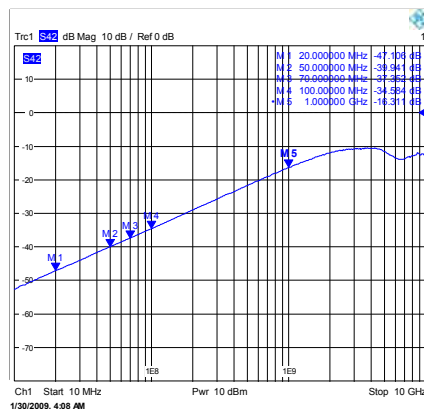

5.1.1 Setup for input frequencies lower than 700 MHz with ZVA24, ZVA40 or ZVA50 (up-conversion)

This case might have the biggest impact on the trace noise. The reason is, that the source from port 1 is attenuated by the loss of the coupler of port 3 that is used as combiner. At 100 MHz the loss is about 35 dB. Additionally, the two tone signal is attenuated again (e.g. 35 dB @ 100 MHz) before it can be measured by the a1 receiver of Port 1.

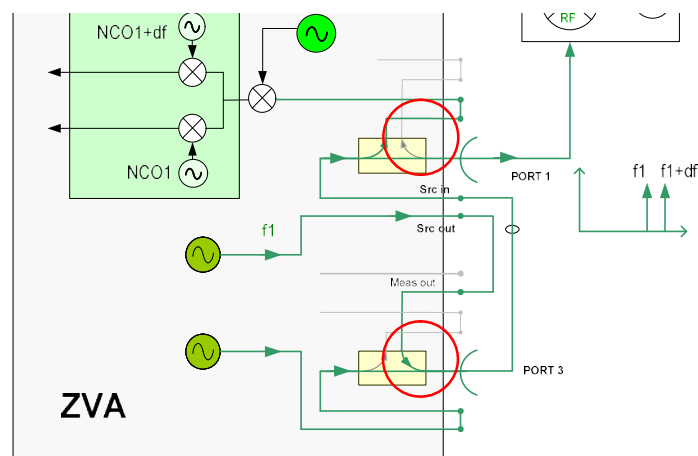

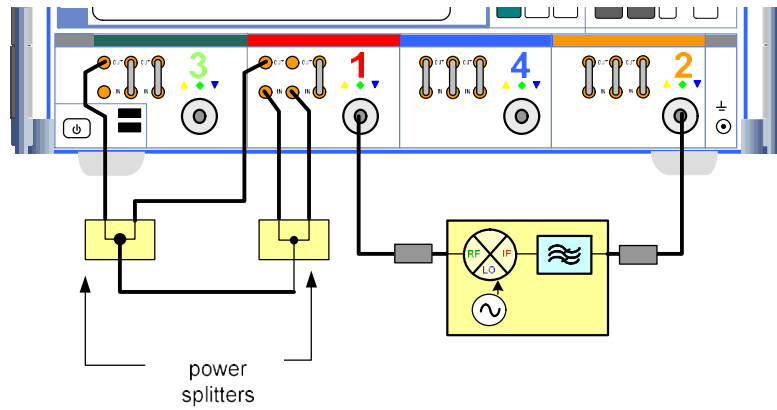

Improvement of trace noise using Power Splitters instead of ZVA-B9

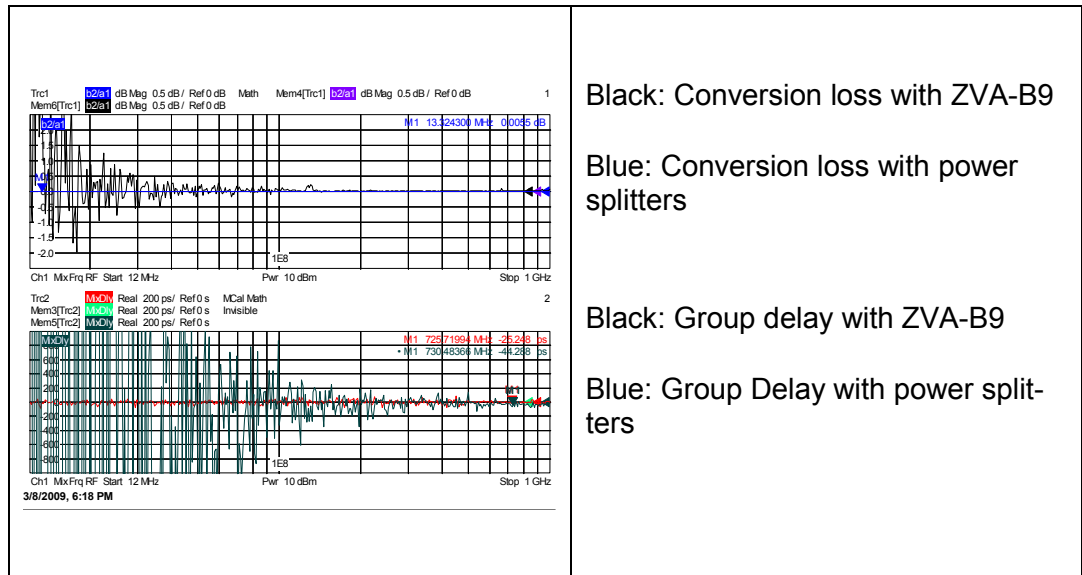

5.1.2 Setup for output frequencies lower than 700 MHz with ZVA24, ZVA40 or ZVA50 (down conversion)

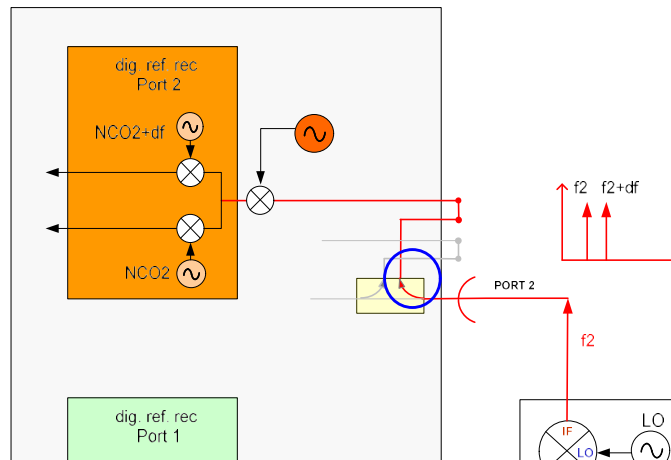

To avoid the coupler loss at Port 2, the direct receiver access can be used. The output of the DUT then is connected to **Meas In** of Port 2 to avoid the loss of the coupler.

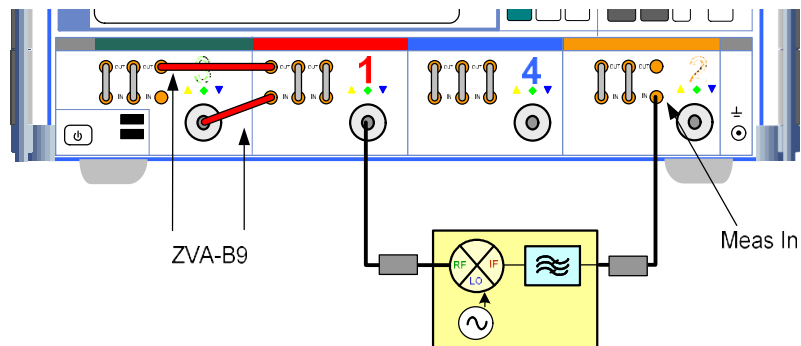

Improvement of trace noise using Meas In instead of Port 2

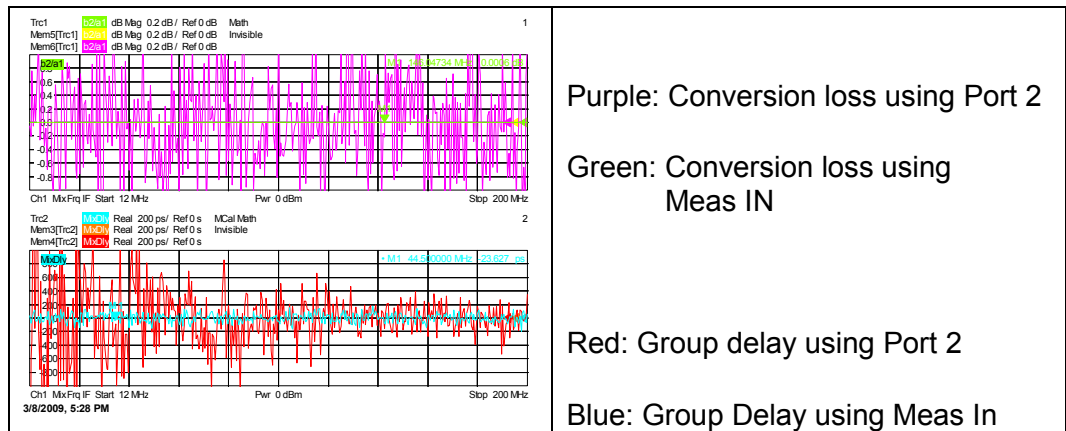

5.2 Searching for the correct LO frequency

Port Configuration

Meas	Phys	Source	Frequency	Frequency Result	Power	Power Result	Receiver	Frequency	Frequency Result
<input checked="" type="checkbox"/>	Port 1	fb	...	5.37 GHz .. 5.45 GHz	Pb	...	fb+ 4.5 GHz	870 MHz .. 950 MHz	
<input checked="" type="checkbox"/>	Port 2	fb	...	5.37 GHz .. 5.45 GHz	Pb	
<input checked="" type="checkbox"/>	Port 3	fb	...	5.37 GHz .. 5.45 GHz	Pb	
<input checked="" type="checkbox"/>	Port 4	fb	...	5.37 GHz .. 5.45 GHz	Pb	

Measure to Waves of
 Receiver Frequency
 Source Frequency

Create a new channel

Press:
CHAN SELECT – ADD CHANNEL+TRACE+ DIAG AERA

MEAS - WAVE QUANTITIES - b2 Src Port 1

MODE – PORT CONFIG

Push fb ...(Frequency) of Port 1

Set the RF frequency to a constant value in the pass band of the DUT.

In this example 5.42 GHz.

Press OK

Port 1 Source Frequency

fb (Channel Base Frequency): 5.37 GHz .. 5.45 GHz

Result: 5.42 GHz

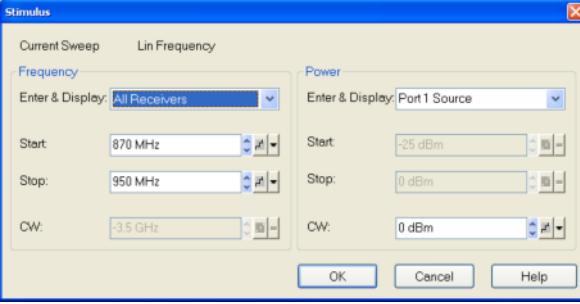
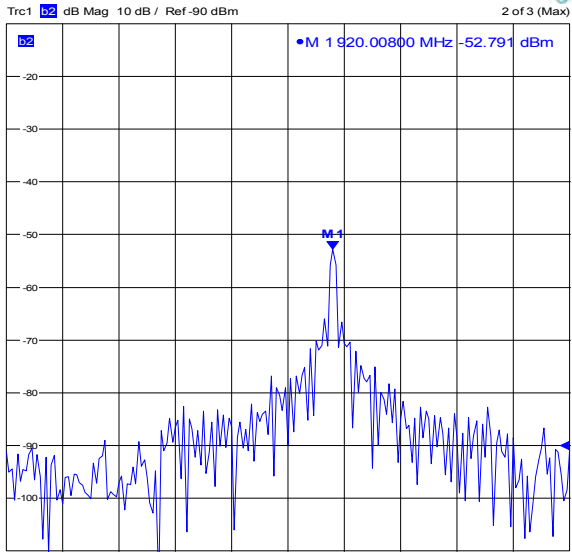
	<p>Set the stimulus axis to the IF frequency</p> <p>Press “Stimulus”</p> <p>Select “All Receivers”</p> <p>Press “OK” two times</p>
	<p>Reduce the span and measurement bandwidth</p> <p>SWEEP - SPAN 100 kHz</p> <p>Pwr BW AVG – MEAS BANDWIDTH: 1 kHz</p> <p>SEARCH – MARKER TRACKING - SEARCH MAX</p> <p>The marker automatically searches for the maximum. The marker value shows the down converted IF frequency.</p> <p>The LO is RF-IF LO = 5.42 GHz-920.008 GHz LO = 4.499992 GHz</p>

6 Ordering Information

Designation	Type	Order No.
Vector Corrected Mixer Measurements ¹⁾	ZVA-K5	1311.3134.02
Embedded LO Mixer Delay Measurements ¹⁾	ZVA-K9	1311.3128.02
Frequency Conversion	ZVA-K4	1164.1863.02
Cable Set for ZVA-K9 for ZVA8	ZVA-B9	1305.6541.02
Cable Set for ZVA-K9 for ZVA24 / ZVA40 2.9mm	ZVA-B9	1305.6541.03
Cable Set for ZVA-K9 for ZVA 50	ZVA-B9	1305.6541.04

¹⁾requires ZVA-K4

About Rohde & Schwarz

Rohde & Schwarz is an independent group of companies specializing in electronics. It is a leading supplier of solutions in the fields of test and measurement, broadcasting, radio monitoring and radiolocation, as well as secure communications. Established 75 years ago, Rohde & Schwarz has a global presence and a dedicated service network in over 70 countries. Company headquarters are in Munich, Germany.

Regional contact

Europe, Africa, Middle East

+49 1805 12 42 42* or +49 89 4129 137 74

customersupport@rohde-schwarz.com

North America

1-888-TEST-RSA (1-888-837-8772)

customer.support@rsa.rohde-schwarz.com

Latin America

+1-410-910-7988

customersupport.la@rohde-schwarz.com

Asia/Pacific

+65 65 13 04 88

customersupport.asia@rohde-schwarz.com

Certified Quality System
ISO 9001
DQS REG. NO 1954 QM

Certified Environmental System
ISO 14001
DQS REG. NO 1954 UM

This application note and the supplied programs may only be used subject to the conditions of use set forth in the download area of the Rohde & Schwarz website.

Rohde & Schwarz GmbH & Co. KG

Mühlhofstraße 15 | D - 81671 München

Phone + 49 89 4129 - 0 | Fax + 49 89 4129 - 13777

www.rohde-schwarz.com