



R&S CMU200 (K20,K21,K22,K23,K24), CMUgo

# GSM Measurements with the R&S CMU200 and CMUgo

## Application Note

This Application Note describes how to test and perform measurements on mobile phones in compliance with the GSM standard using the R&S CMU200 by means of the remote-control program CMUgo or manual operation.



### **Contents**

1	Overview .....	3
2	Introduction .....	3
3	Manual Operation of the R&S CMU200.....	3
	Call setup and release .....	3
	Auxiliary RF generator (AuxTX - option B95) .....	3
	Analyzer mode .....	5
	Call setup.....	6
	Measurements .....	8
	Overview.....	8
	Power .....	8
	Modulation .....	10
	Spectrum .....	10
	Receiver quality .....	12
	Audio (option B41 required).....	13
	AMR.....	16
4	Remote Control of the R&S CMU200 with CMUgo .....	18
	Software features .....	18
	Hardware and software requirements .....	18
	Hardware requirements .....	18
	Software requirements .....	18
	Using CMUgo .....	18
	GSM Call Setup module .....	18
	GSM Call Release module .....	21
	GSM Testset module.....	22
	GSM Call Edge module .....	26
	GSM Multislot Test module .....	28
	GSM Audio Setting module .....	29
	GSM BER Search module.....	31
	GSM Call AMR module .....	32
	GSM Call Change Multislot module.....	33
	GSM Channel Scan module .....	33
	GSM Call Echo Test module .....	35
	GSM PowerPCL module .....	35
5	Appendix.....	37
	List of Figures .....	37
	Remote Sequences .....	38
	GSM Call Setup.....	38
	GSM Call Release .....	40
	GSM Testset .....	40
	GSM Call Edge.....	41
	GSM Multislot Test .....	41
	GSM Audio Settings .....	42
	GSM AMR .....	42
	GSM Change Multislot.....	43
	GSM Channel Scan.....	43
	GSM Call Echo Test.....	44
	GSM PowerPCL .....	44
	Abbreviations .....	45
	References .....	45
	Additional information .....	45

## 1 Overview

The Radio Communication Tester R&S CMU200 can be used to perform fast and accurate measurements of various standards such as GSM, IS-136, AMPS, CDMA, cdma2000, 1xEVDO, WCDMA and *Bluetooth*<sup>®1</sup>.

This Application Note describes how to use CMUgo, a Windows application for remote control of the R&S CMU200 and for measuring and testing mobile phones in compliance with the GSM standard.

## 2 Introduction

Although the “old” 2nd generation GSM mobile radio standard is threatened by a 3rd generation (WCDMA, cdma2000), it has been expanded by the new functions EDGE and (E)GPRS (2.5 generation), which will surely extend its life-span. Most telephones on the market still use GSM or offer GSM as fallback options.

This Application Note intends to analyze aspects of the CMU in accordance with the pure GSM standard of the 2nd generation. A separate Application Note [3] deals with newer functions such as GPRS and EGPRS.

This Application Note does not attempt to explain the associated theory in full detail but rather simply provides a brief summary of the most important aspects.

## 3 Manual Operation of the R&S CMU200

### Call setup and release

#### Auxiliary RF generator (AuxTX - option B95)

In the standard GSM environment, a single generator in the CMU is still sufficient for testing the mobile phones. Here, the CMU generates the BCCH in timeslot 0. Timeslots 1 and 7 are disabled due to settling times; timeslots 2 to 6 are therefore available for the TCH (Fig. 1).

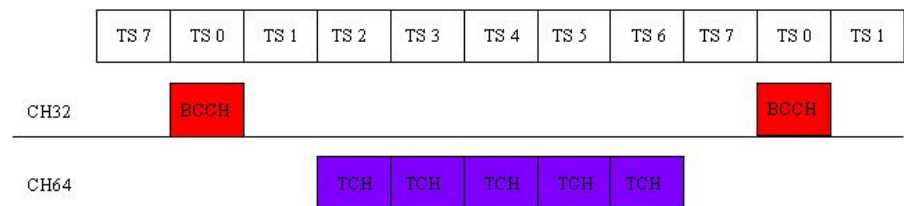

Fig. 1 - Downlink on two channels without option B95

Fig. 2 shows the required CMU settings in the **BS Signal** tab. The **BCCH Channel** and **TCH Channel** parameters are particularly important here. The **BCCH Level** and the **Main Timeslot** can also be set here. The **Mode** parameter is only relevant for the conventional GSM mode; the BCCH can be disabled following call setup BCCH or TCH to allow measurements on all timeslots.

<sup>1)</sup>The *Bluetooth* word mark and logos are owned by the Bluetooth SIG, Inc. and any use of such marks by Rohde&Schwarz is under license.

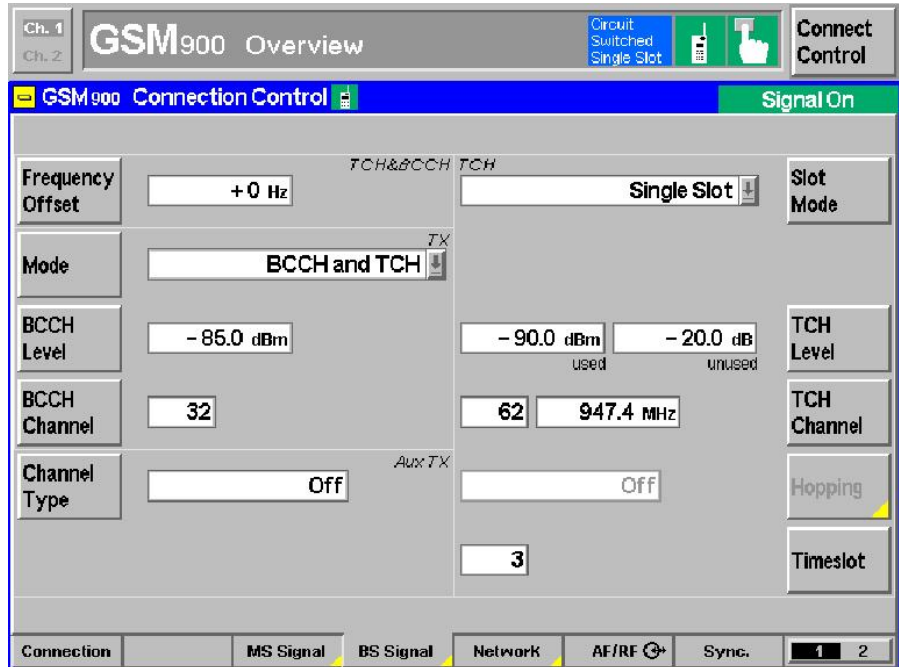

Fig. 2 – CMU setup for BS signal without option B95

Since the GPRS mode transmits data only when required instead of continuously, most mobile phones perform a power measurement on the BCCH at undefined points in time. If this measurement fails, the call is automatically released by the mobile phone. The CMU now provides two ways of preventing this:

- BCCH and TCH are on the same channel. This means that an auxiliary generator is not required. However, a channel change or dual-band handover (Fig. 3) cannot be performed.
- If the auxiliary generator is available, a permanent BCCH is generated and channel change and dual-band handover are possible (Fig. 4).

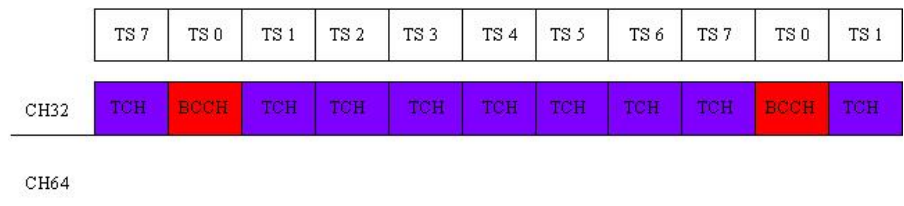

Fig. 3 - Downlink on the same channel without option B95

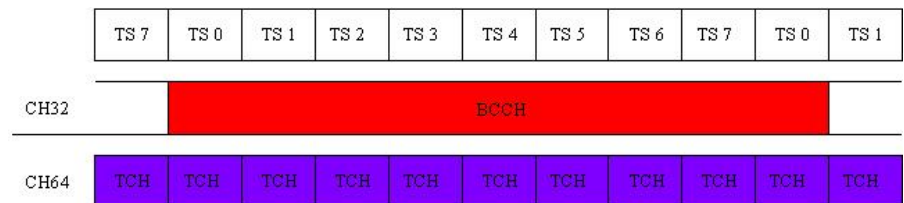

Fig. 4 - Downlink with option B95

Fig. 5 shows the **BS Signal** tab when option B95 is used.

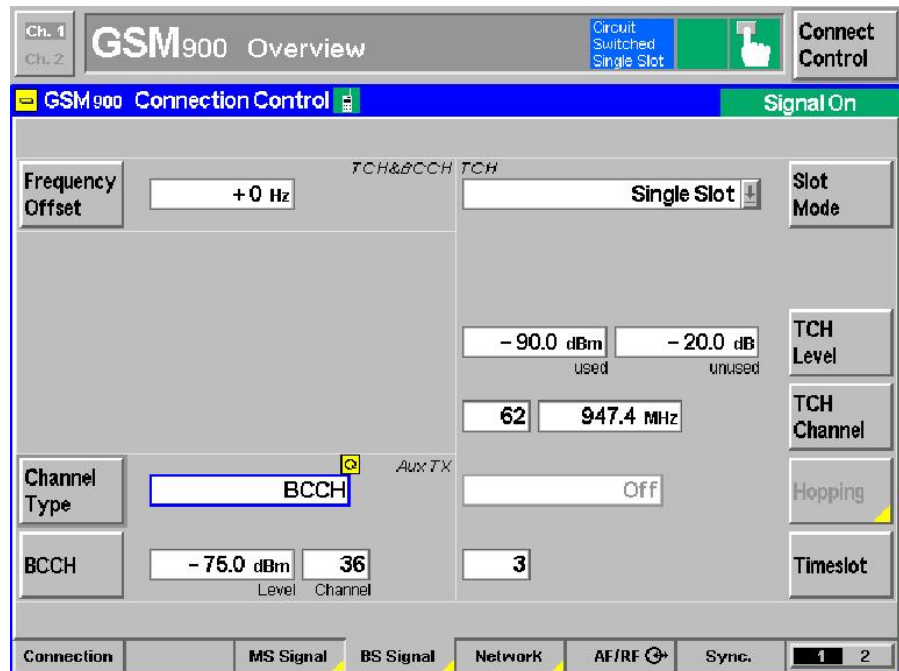

Fig. 5 – CMU setup for BS signal with option B95

A number of restrictions apply if the option B95 is used:

- Max. 2 W RMS can be applied at the RF1 connector.
- RF3 out cannot be used while option B95 is being used.
- A maximum of -60 dBm can be set as the BCCH level at RF2.

### Analyzer mode

In GSM, the CMU generally has three modes in the signalling mode, and two of them ensure easy operation. In the **AUTO** mode, the CMU first measures the mobile phone power and automatically adjusts itself to this power. Due to this additional measurement, this mode is slower than the recommended **PCL/Gamma** mode. The CMU thus automatically adjusts to the mobile phone power expected due to the PCL value (Fig. 6). In the **Manual** mode, you have to set the required level manually.

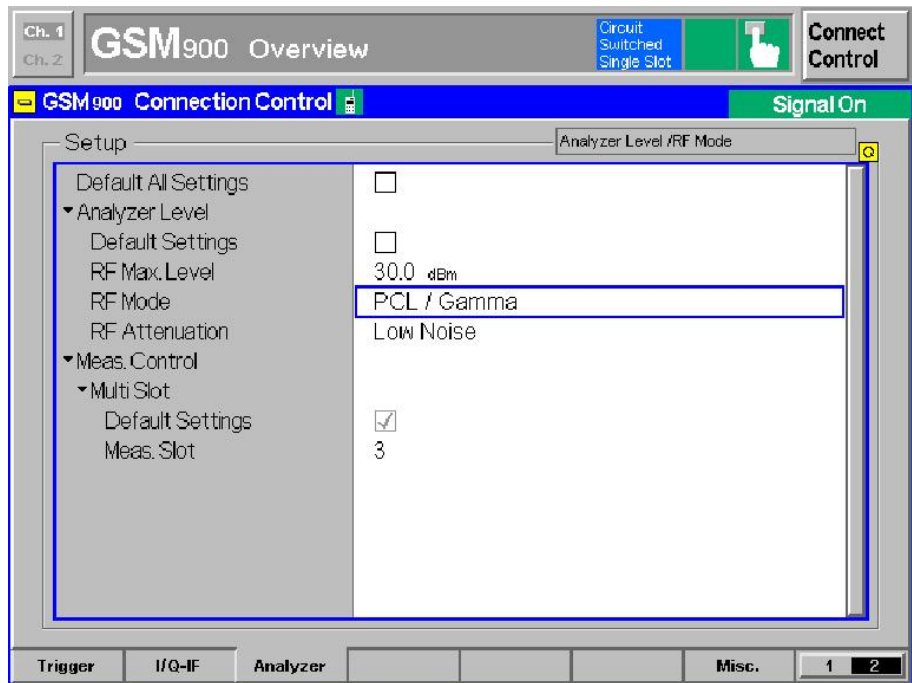

Fig. 6 – Analyzer mode

**Call setup**

Fig. 7 again shows the default state of the CMU. The BCCH is generated and the CMU waits for the mobile phone location update.

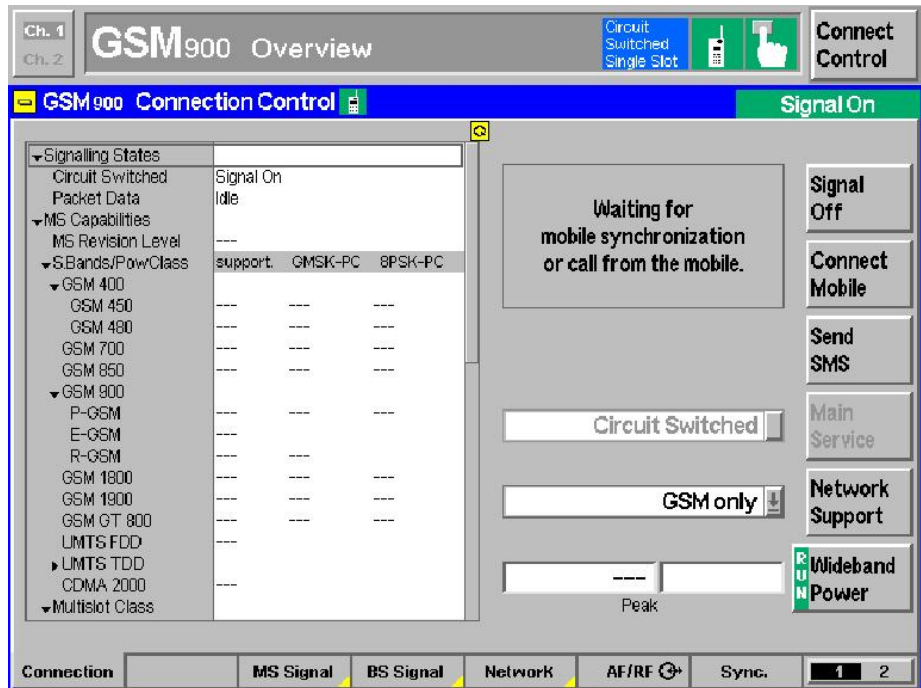

Fig. 7 – Default state of the CMU



## GSM with R&S CMU and CMUgo

After the location update, the CMU switches to the synchronized state (Fig. 8). Now you can set up a call to or from the mobile phone by pressing **Connect Mobile**.

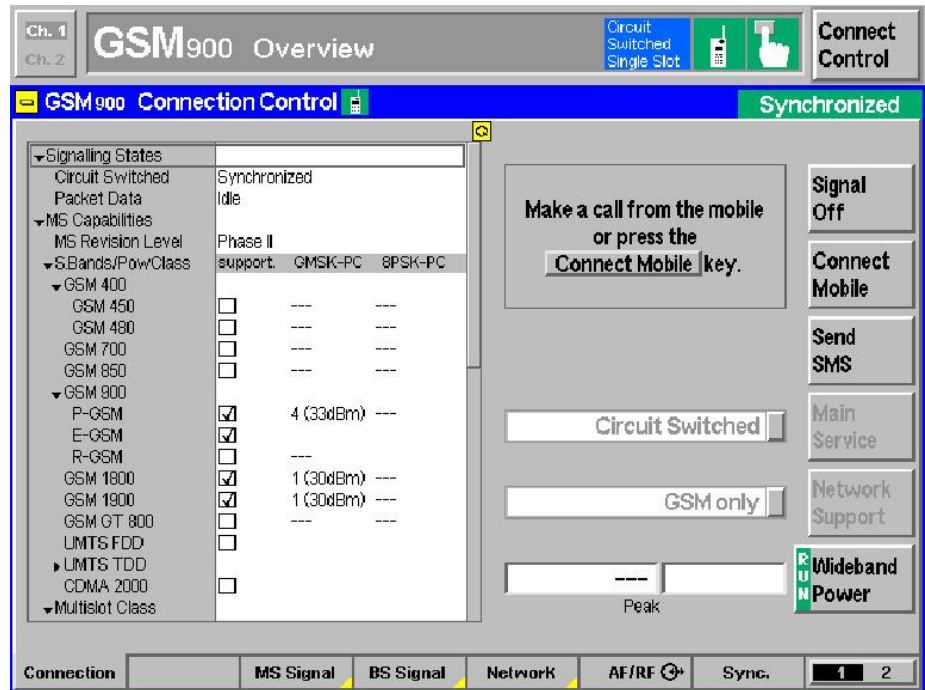

Fig. 8 - CMU in the synchronized state

Fig. 9 again shows the internal states in the CMU. GSM and (E)GPRS are identical up to the **Attached** and **Synchronized** state, i.e. a circuit-switched call is also possible in the **Attached** state.

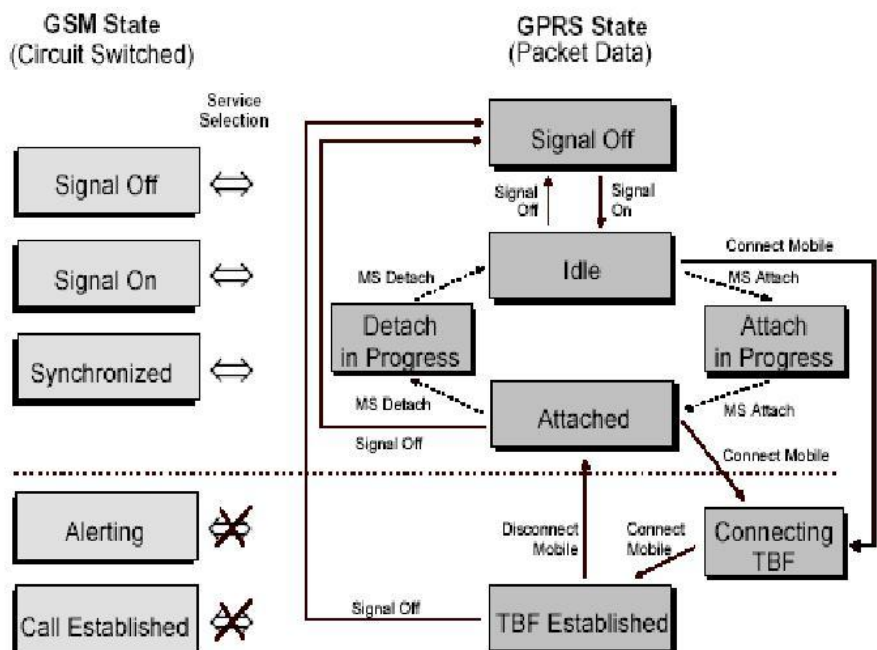

Fig. 9- (E)GPRS states in the CMU

If the CMU is in the **Call Established** state, you can perform the individual measurements.

### Measurements

The individual measurement menus are displayed in the lower row. Individual connection parameters (e.g. channel, PCL, etc) as well as measurement parameters can be varied in the column at the right edge.

### Overview

The **Overview** menu displays the most important mobile phone parameters (Fig. 10).

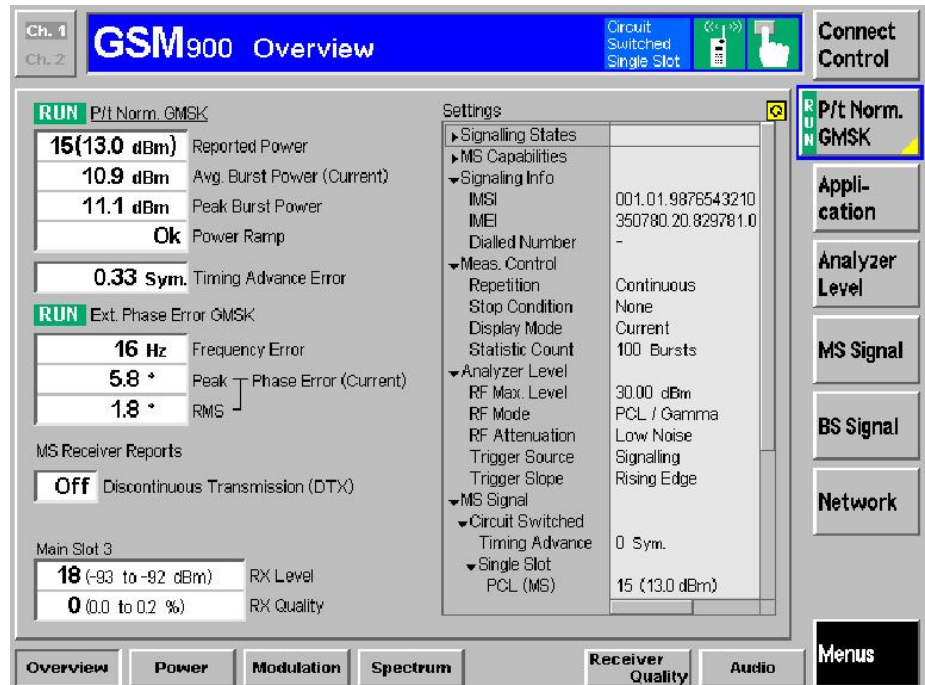

Fig. 10 – Overview menu

### Power

This section discusses the individual power measurements in detail.

Fig. 11 shows the typical time characteristic of a GSM signal. Fig. 12 shows the **PowerPCL** measurement, which is a quick measurement on three or seven channels across all PCLs.

The measurements required for the 2.5 generation (e.g. 8SPK) are described under [3]. No other measurements are discussed here.



## GSM with R&S CMU and CMUgo

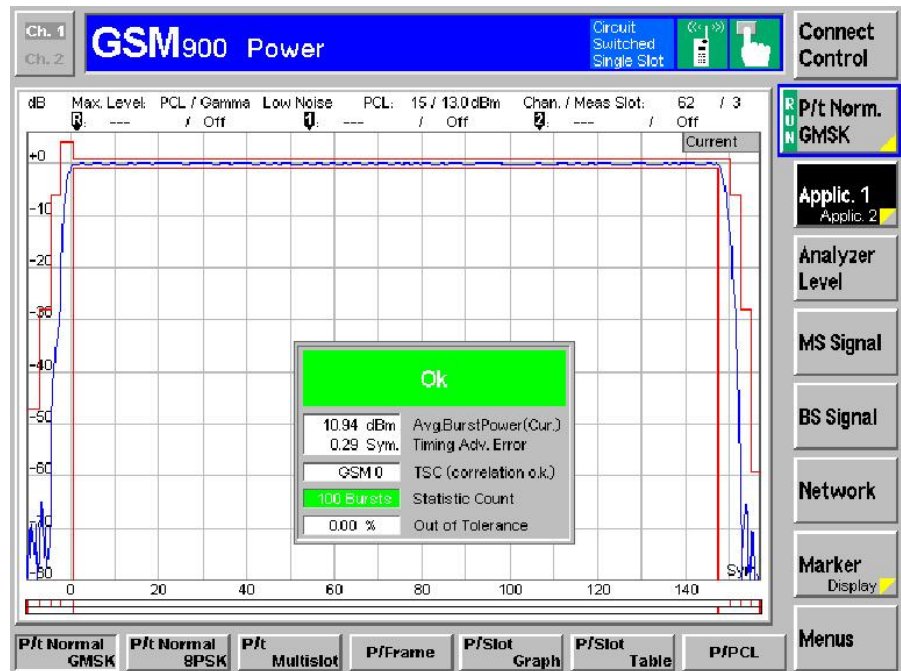

Fig. 11 - Power vs time measurement

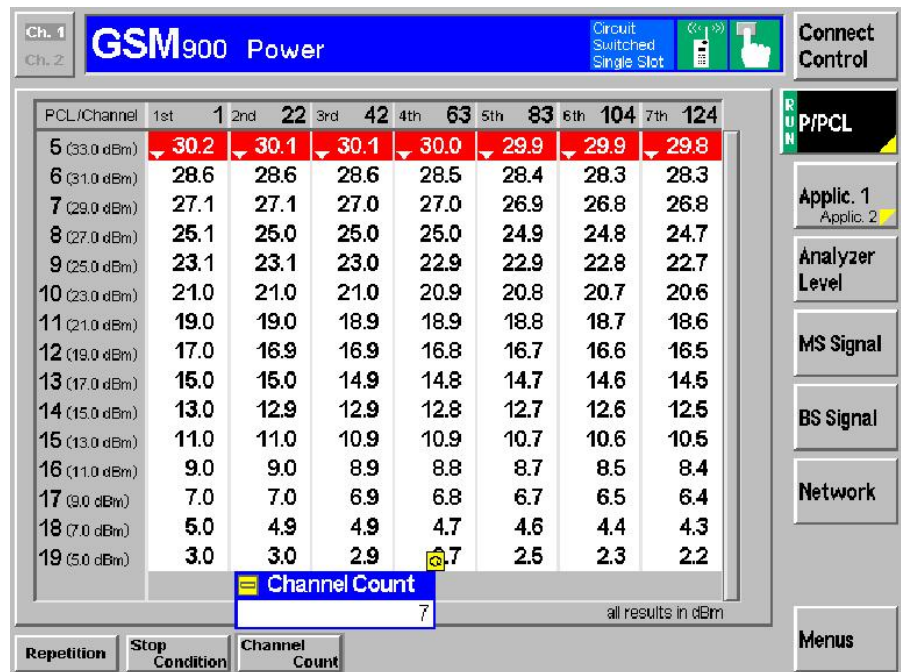

Fig. 12 – PowerPCL

## Modulation

Fig. 13 shows a GSM modulation measurement

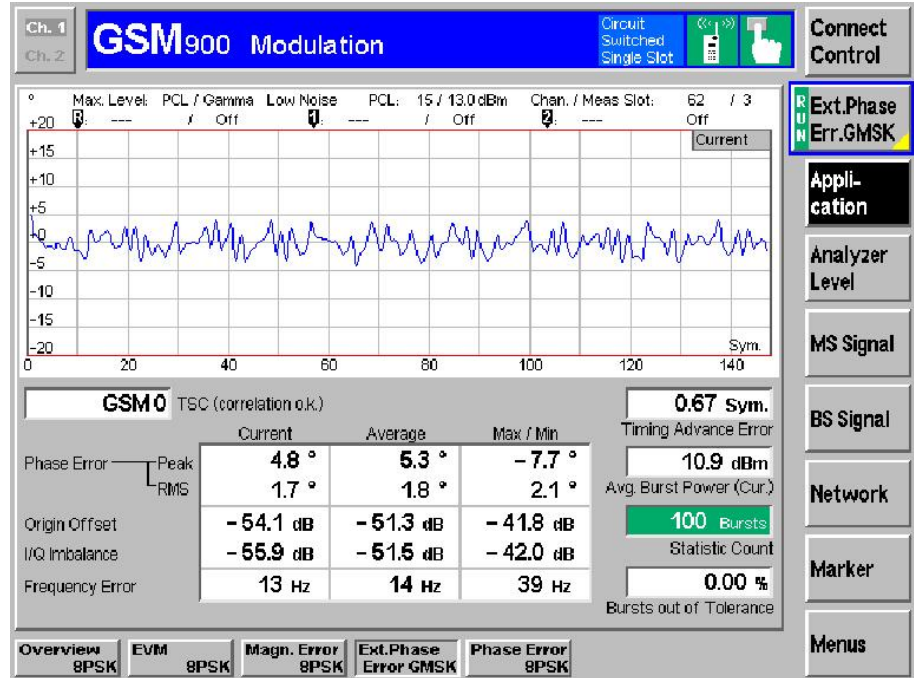

Fig. 13 – Modulation

## Spectrum

The CMU offers three spectrum measurements. With the **Spectrum due to Modulation** and **Spectrum due to Switching** measurements, the corresponding time domain is also displayed (Fig. 14 and Fig. 15). The **Spectrum MSW** measurement performs both measurements simultaneously and displays them together in a window (Fig. 16). Note the difference in the measurement displays: spectrum modulation uses dB and switching uses dBm.

## GSM with R&S CMU and CMUgo

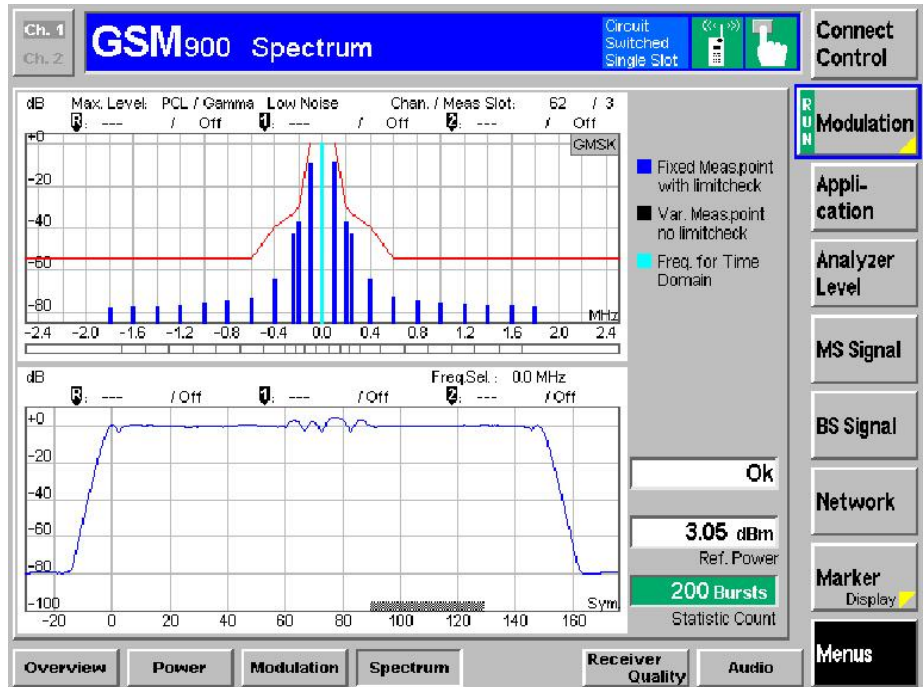

Fig. 14 - Spectrum due to modulation

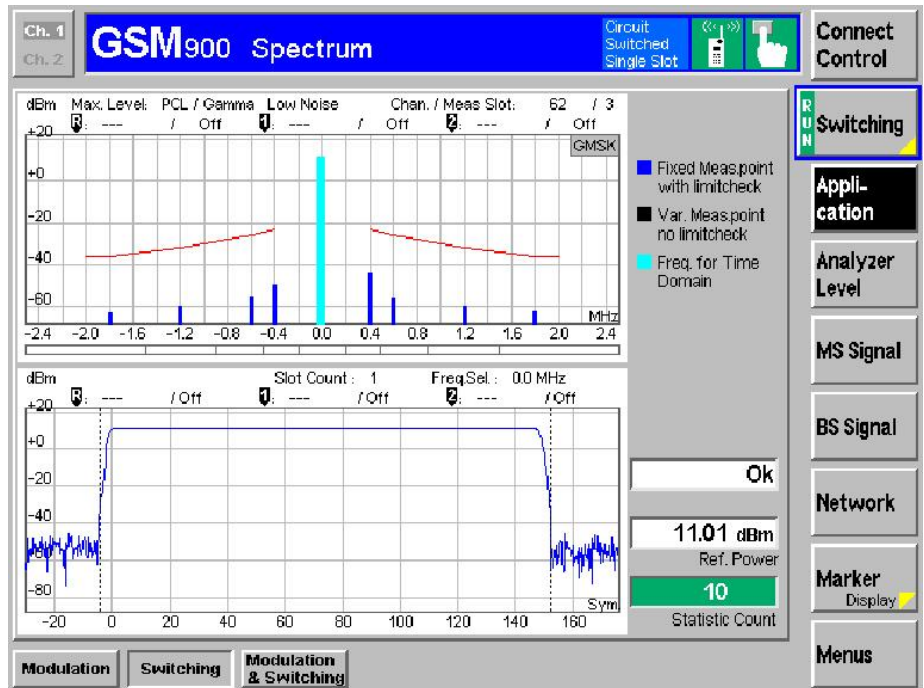

Fig. 15 - Spectrum due to switching

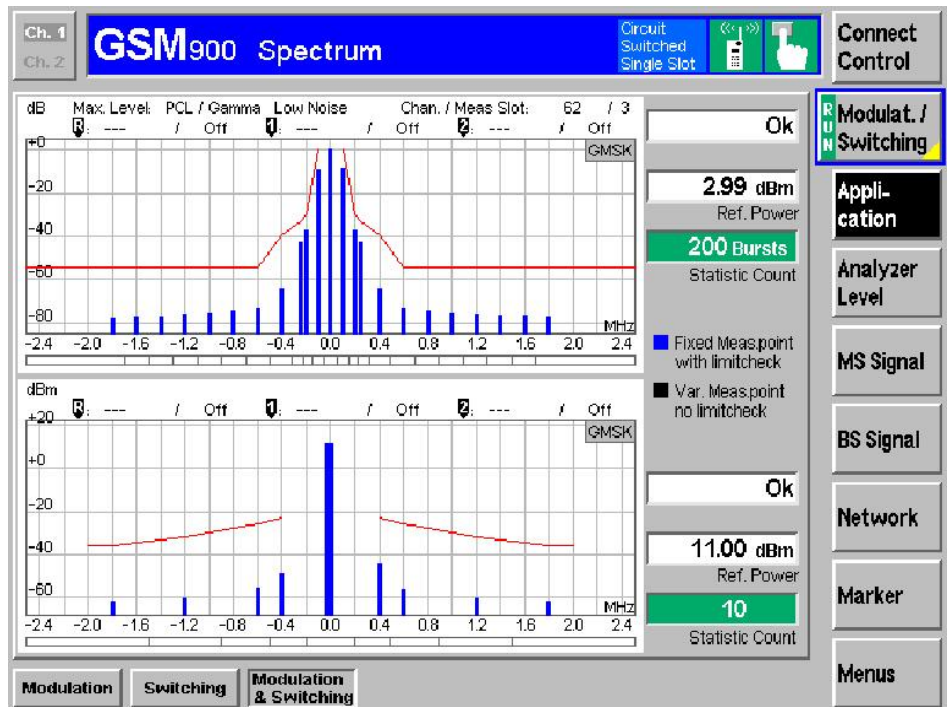

Fig. 16 – Combined spectrum measurement

### Receiver quality

A pseudo random signal that can be set is generated by the CMU to assess the Receiver Quality. This signal is then sent back by the mobile phone. Pressing the **Meas. Mode** button provides, three different measurement methods. **BER** calculates the BER via the class II bit. **RBER/FER** additionally calculates the frame error rate (FER). **BBB** or **Fast BER** closes the loop without the Channel Coder, i.e. more bits per frame are available for measurement. If the test depth is the same, **BBB** is quicker. To measure the 10000 bits typical for production, **BER** and **FBER** require 129 frames and **BBB** 88 frames.

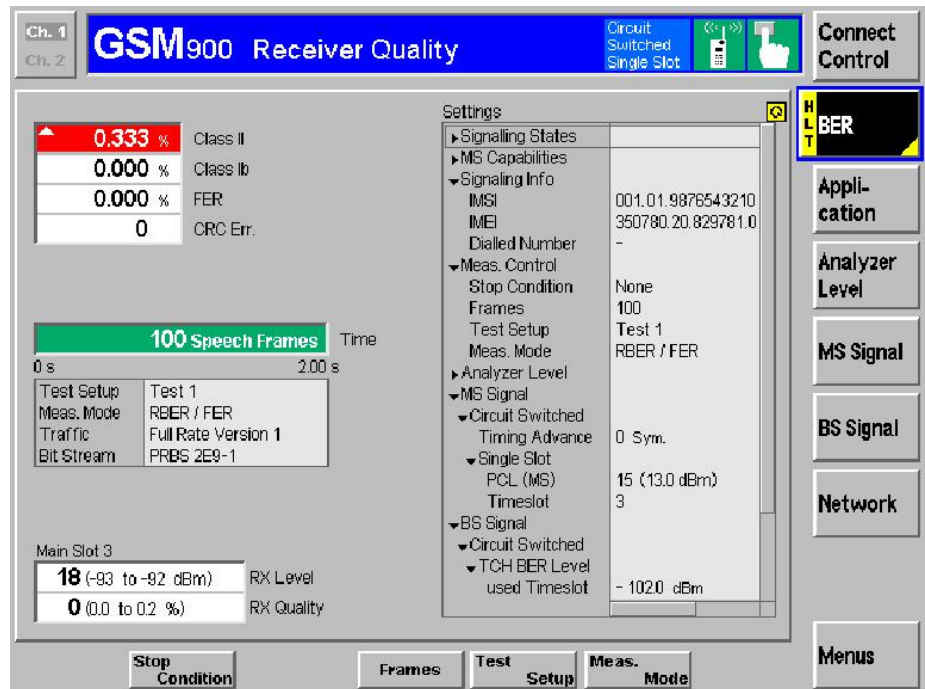

Fig. 17 - Receiver quality

**Audio (option B41 required)**

Before audio measurements are performed, the correct path must be set in the CMU. To do this, you must set **Bit Stream** to Speechcoder/Handset both for the uplink and downlink (Fig. 18).

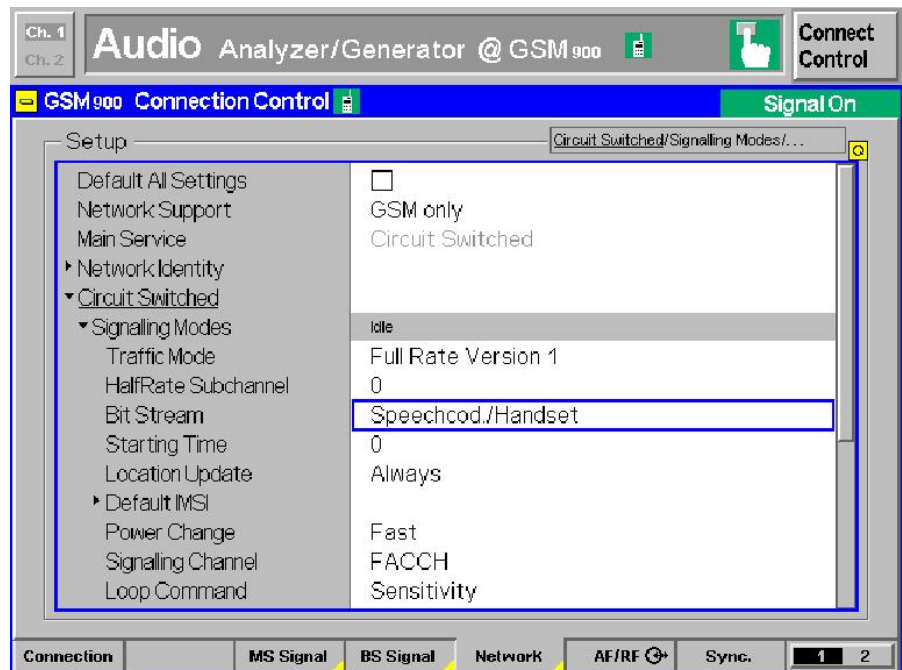

Fig. 18 - Audio setting: Bit Stream

**Audio uplink**

In the uplink, the CMU generates audio signals and provides them at AF OUT. A connected loudspeaker feeds these signals to the mobile phone microphone, which sends the signals via the speech encoder using RF and the speech decoder of the CMU. Finally, the signals are displayed in the **Audio** menu (Fig. 19 and Fig. 20).

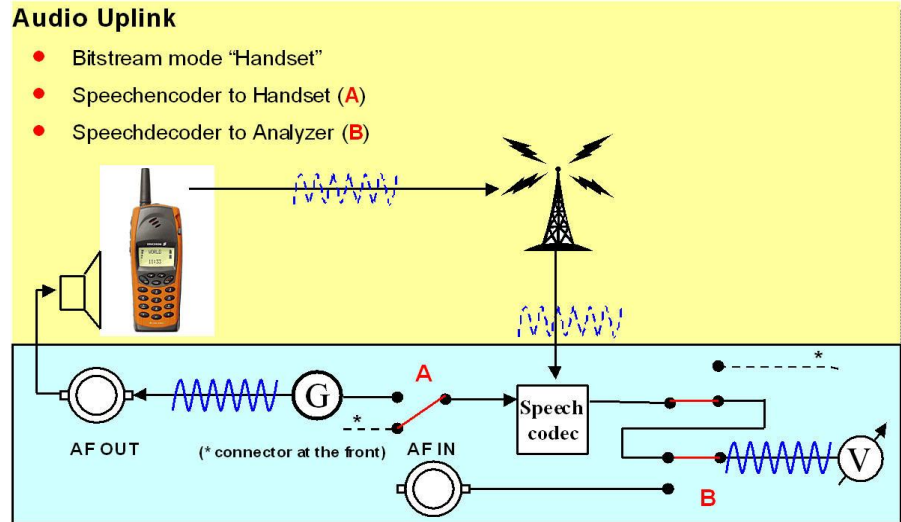

Fig. 19 - Audio uplink in the CMU

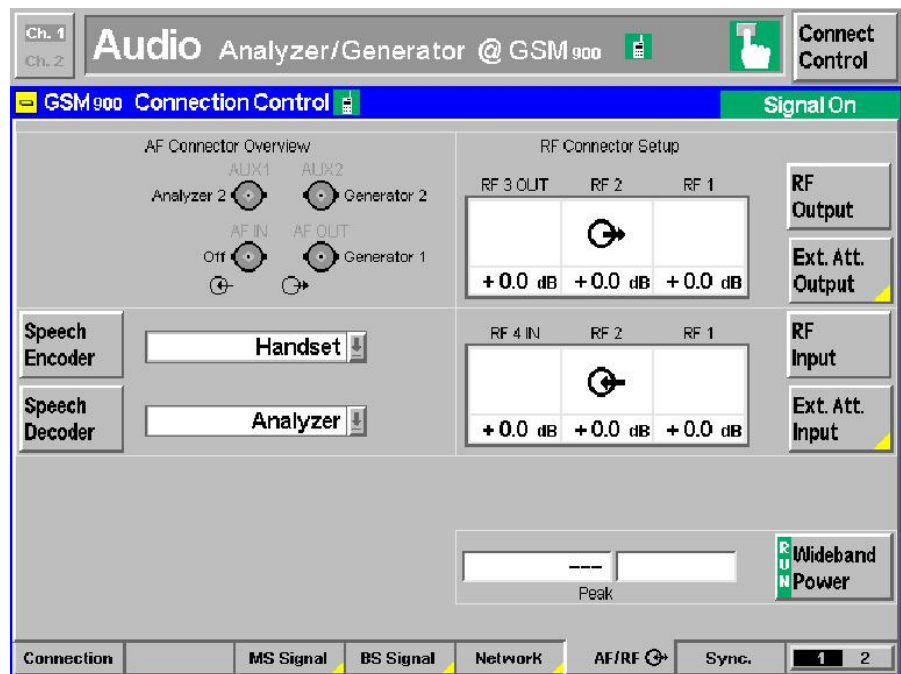

Fig. 20 - Audio uplink setting

**Audio downlink**

Here, the audio signals generated by the CMU are sent to the mobile phone via the speech coder using RF. The mobile phone decodes the signals and outputs them on the loudspeaker. The measurement values are displayed



in the **Audio** menu by means of a microphone which is connected via AFIN (Fig. 21 and Fig. 22).

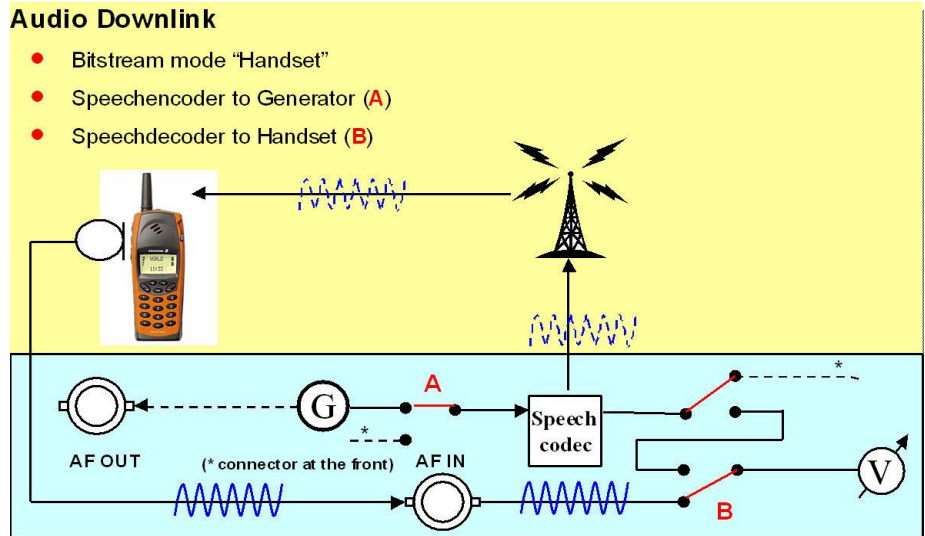

Fig. 21 - Audio downlink in the CMU

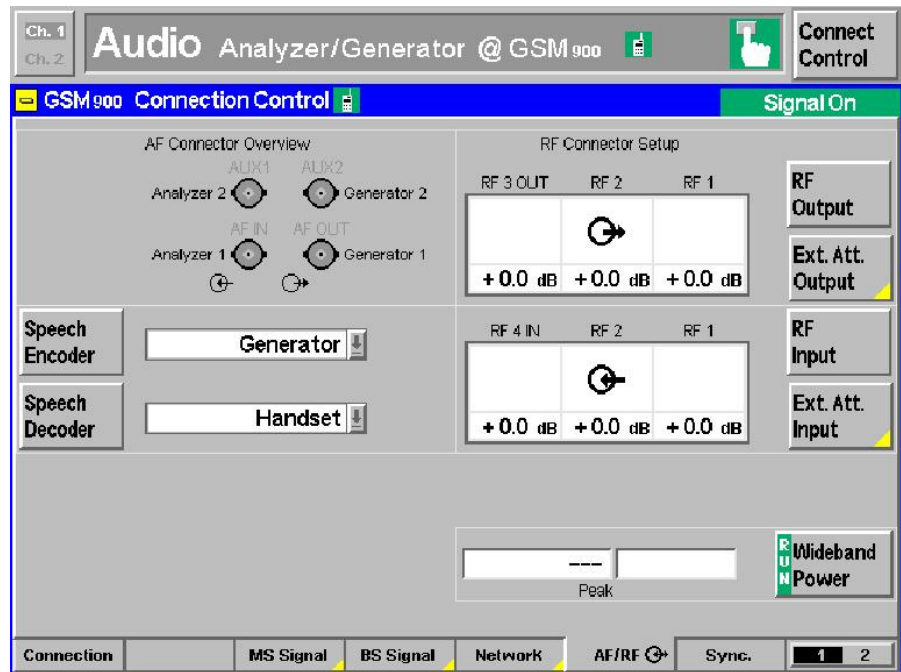

Fig. 22 – Audio downlink setting

**Measurements**

Fig. 23 and Fig. 24 show the audio generator and audio analyzer of the CMU.

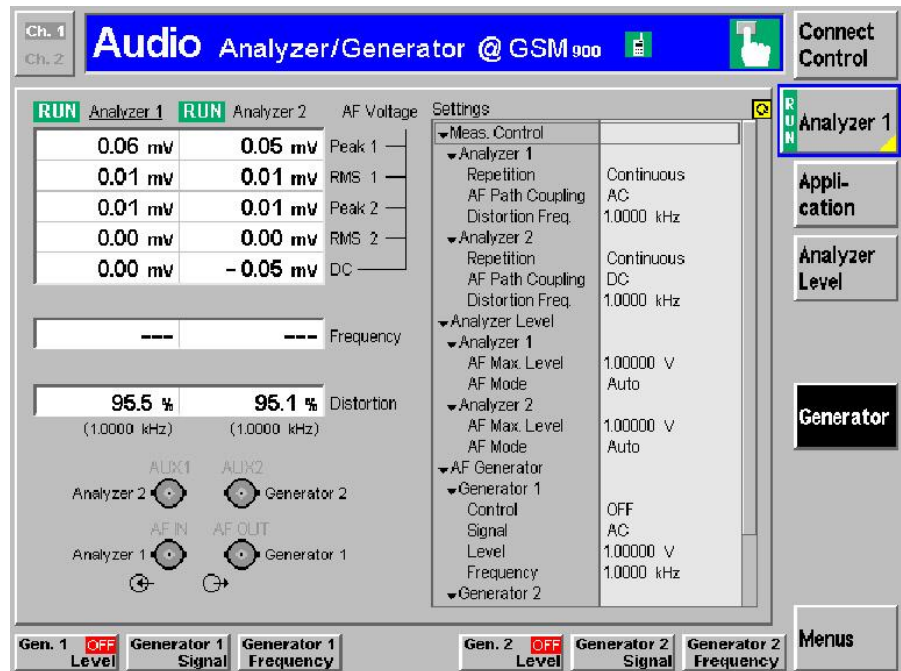

Fig. 23 - Audio generator

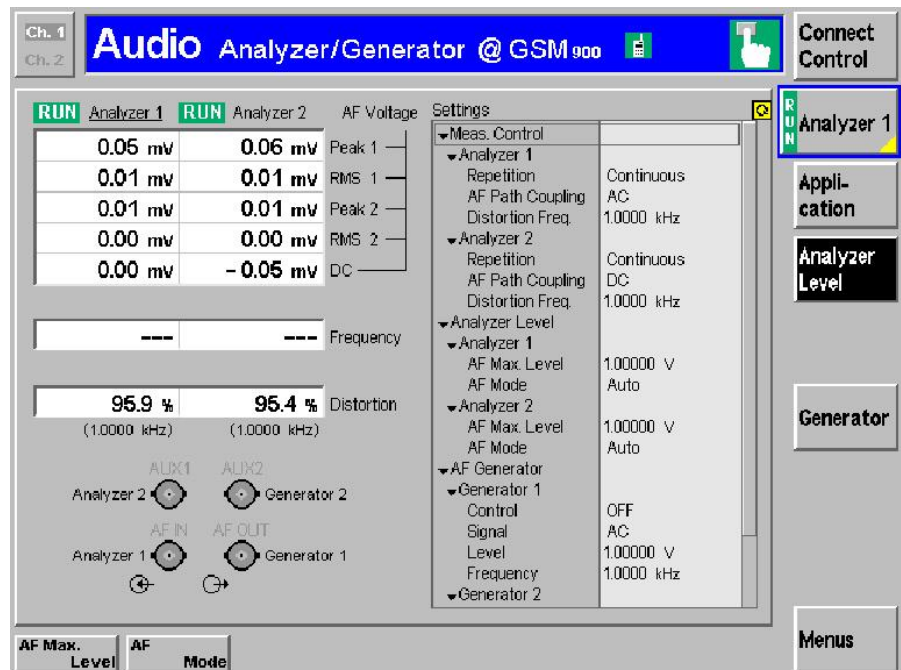

Fig. 24 - Audio analyzer

**AMR**

Fig. 25 shows the implementation of AMR in the CMU. The mobile phone measures the signal-to-noise ratio at a specific level and requests a codec at the base station (requested by MS).

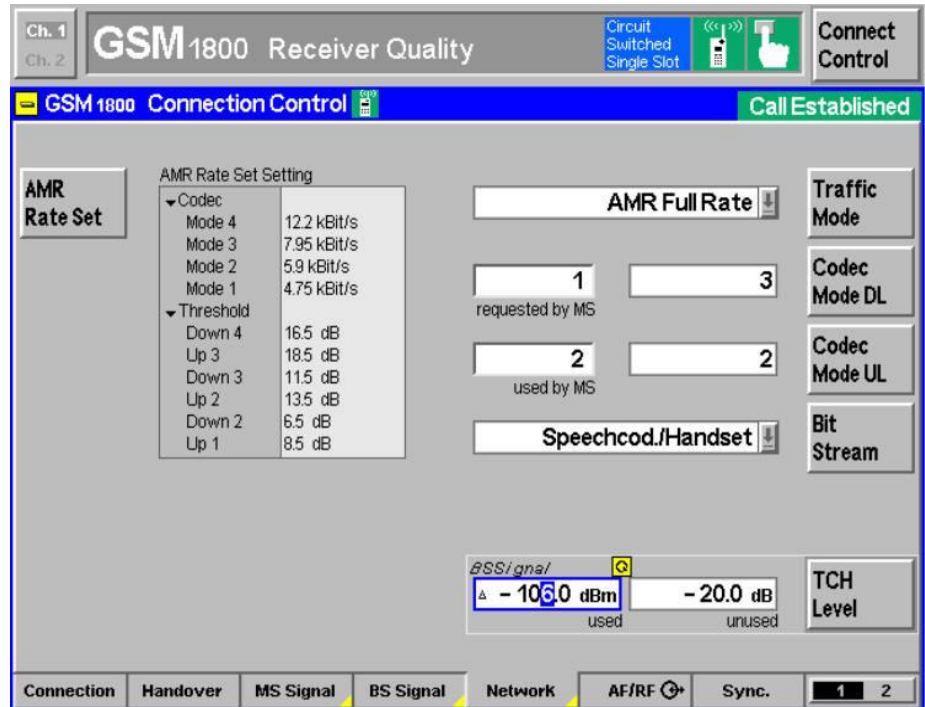

Fig. 25 – AMR

To avoid having to continuously switch back and forth, a hysteresis mechanism can be set (Fig. 25 left and Fig. 26).

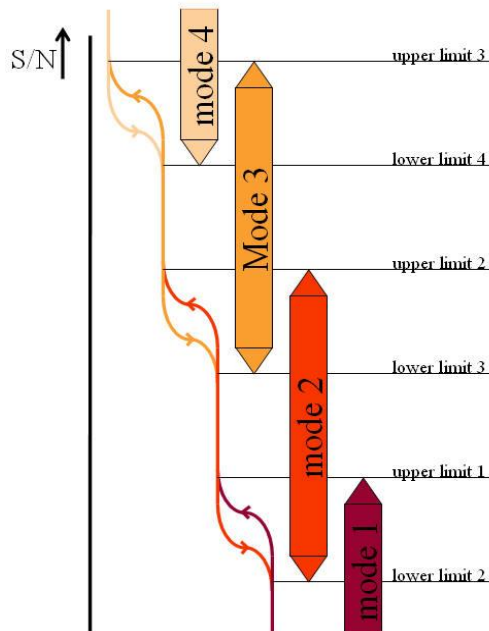

Fig. 26 - AMR hysteresis

## 4 Remote Control of the R&S CMU200 with CMUgo

### Software features

CMUgo offers a simple user interface for remote control of the R&S CMU200 both via a GPIB bus (IEEE488.2) and via the RS-232-C interface. CMUgo can handle all standards available on the R&S CMU200.

CMUgo includes a feature for outputting test reports. Moreover, a report of the remote-control commands with the times of the individual steps can be output, and the remote-control commands can be copied directly to the Windows clipboard for further processing.

### Hardware and software requirements

#### Hardware requirements

- CPU: min. 300 MHz
- RAM: min. 64 Mbyte
- Monitor: SVGA with min. 800 x 600 pixels
- Hard disk: 50 Mbyte of free space
- Peripherals: National Instruments GPIB bus or RS-232-C interface, mouse

#### Software requirements

- Windows 98/ME/2000/XP
- CMUgo V1.51 with GSM modules V1.51 or later

### Using CMUgo

Please refer to the CMUgo manual [2] for information on how to connect the computer and the R&S CMU200, as well as how to install, start and operate CMUgo.

With CMUgo, the remote sequence can be output by using the **Demo** function. You can then create your own sequences on the basis of this sequence. CMUgo tries to perform the test sequences as quickly as possible. Since the program is structured as a sequencer (information about the previous module is not available), you may be able to save time by optimizing it further.

### GSM Call Setup module

In the **GSM Call Setup** module, all parameters that are relevant for establishing a GSM connection are set in the **Circuit-Switched** mode (Fig. 27). Under **Network**, you select the band in which the BCCH is to be generated, and which will be used for the location update. In the **BCCH** section, you define whether the BCCH is to be generated with AuxTX (option B95); You also set the channel and level of the BCCH here. The channel and level of the TCH that is used are selected under **TCH after call setup**. In addition to pure GSM, you can also select GPRS or EGPRS

## GSM with R&S CMU and CMUgo

under **Support** in **Network Setup** . Thus, the CMU already generates a BCCH here with information about (E)GPRS so that additional (E)GPRS tests can be performed after the GSM test without carrying out another location update. The **Slot** mode differentiates between a single slot (conventional GSM (voice or data) and the **Multislot** mode (data only). If you select **Single Slot**, CMUgo uses the parameters under **Single Slot Configuration**; in the **Multislot** mode, an additional dialog is available (see Fig. 30). Now you have to specify the call direction: **Call to mobile** (MTC) or **Call from mobile** (MOC). Moreover, the phone can automatically be controlled via AT commands here: **from mobile (voice, AT commands)** sends ATD sends and the number listed **under the dialed number should be** to the phone; **from mobile (data, AT commands)** opens an additional dialog box in which you can enter any AT commands (Fig. 28). Finally, **Attenuations** allows you to specify the RF connector and the input and output attenuation.

Call Setup Configuration

Network: GSM 900

BCCH

use AuxTX ( B95 )

RF Channel: 30

RF Level: -85

TCH after call setup

RF Channel: 62

RF Level: -85

Network Setup

Support: GSM

Slot Mode: Single Slot

Single Slot Configuration

PCL: 15

Timeslot: 3

The dialed number should be:

1234567890

Call:

to mobile

Send SMS

Attenuations

Input: 0

Output: 0

CMU Connector:

RF1

RF2

OK

Cancel

MultiSlot Configuration

Configure...

Fig. 27 - Call Setup configuration

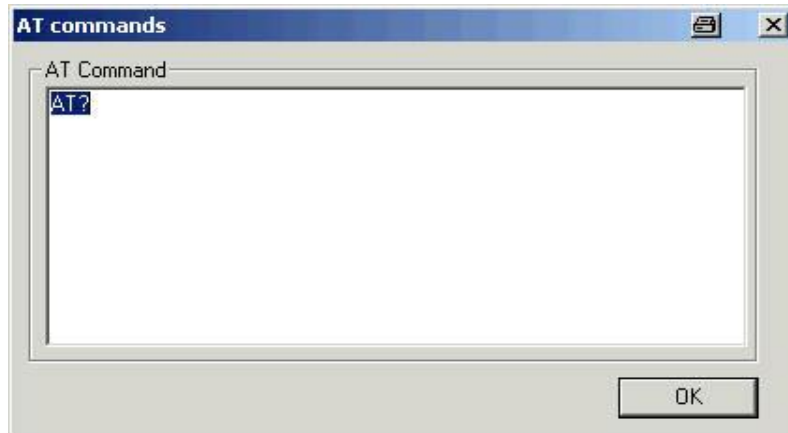

Fig. 28 - Call Setup: AT commands

The **Configure** button opens the **Additional Configuration** dialog box (Fig. 29).

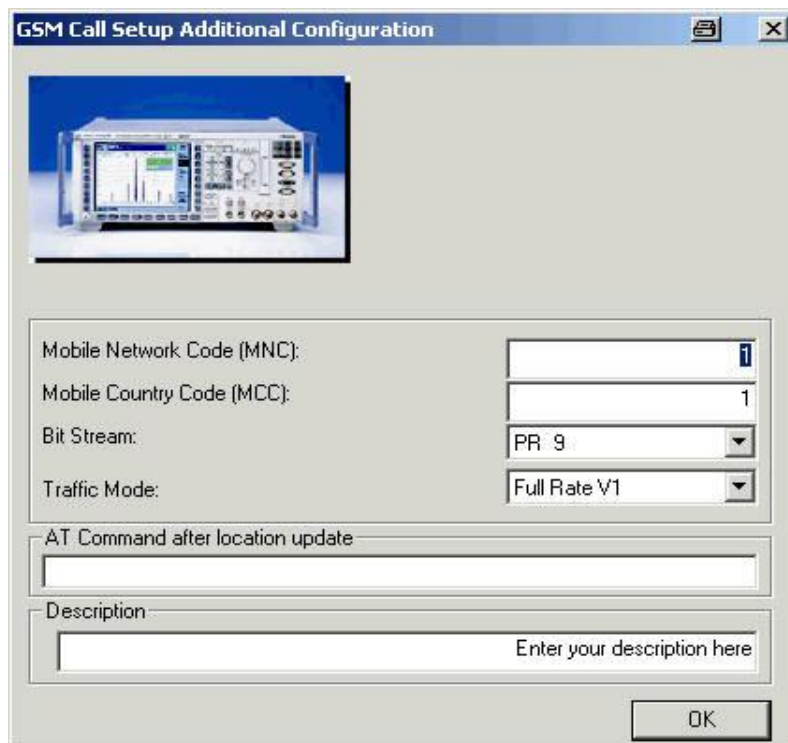

Fig. 29 - Call Setup: additional configuration

Here, you can set additional parameters such as **MNC**, **MCC**, **Bit Stream** and **Traffic Mode**. Moreover, you can send an AT command to the mobile phone after the location update and before call setup.

The **Multislot Configuration** button allows you to to customize the multislot setting for the call with multiple timeslots .



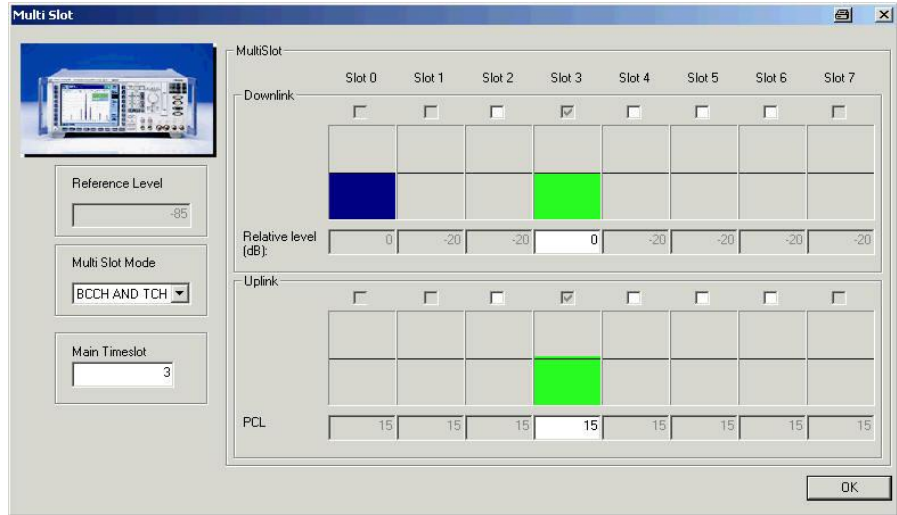

Fig. 30 - Call Setup: multislot

First, you can set the **Main Timeslot** here. The **Main Timeslot** is automatically activated in the graphical **Multislot** section. The blue slot indicates the BCCH, grey slots indicate deactivated slots without level, dark green slots indicate non-activated slots with a defined level, and light green slots indicate activated slots. In the **Downlink** section, slots can be activated and a level relative to the reference level can be set. In the **Uplink** section, the required slots are activated and the PCL value to be used by the mobile phone can be specified.

Fig. 31 shows a typical **Call Setup** entry in the test report.

```

Network: GSM 900, BCCH Channel/Level: 30/-85.0 dBm, TCH Channel: 62, TCH Level (dBm): -85.0, Support GSM, PCL: 15
(Main) Timeslot: 3, Attenuation (In/Out): 0.0/0.0 dB, Slot Mode: Single Slot, Bitstream: PR9, AuxTX: Off
Traffic Mode: Full Rate V1
IMSI: 0.0.1000000095, IMEI: 0.0.0.0, Revision: PH2P, Number: 1234567890, Traffic: FRV1, Power Class: 4
Call to Mobile: [ ] [ ] passed ✓
    
```

Fig. 31 - Call Setup report

## GSM Call Release module

The GSM **Call Release** module is used to release the active call to the mobile phone; the R&S CMU200 enters the synchronized state (Fig. 32). If **Free all CMU resources** is activated, the instrument changes to the SOFF state.

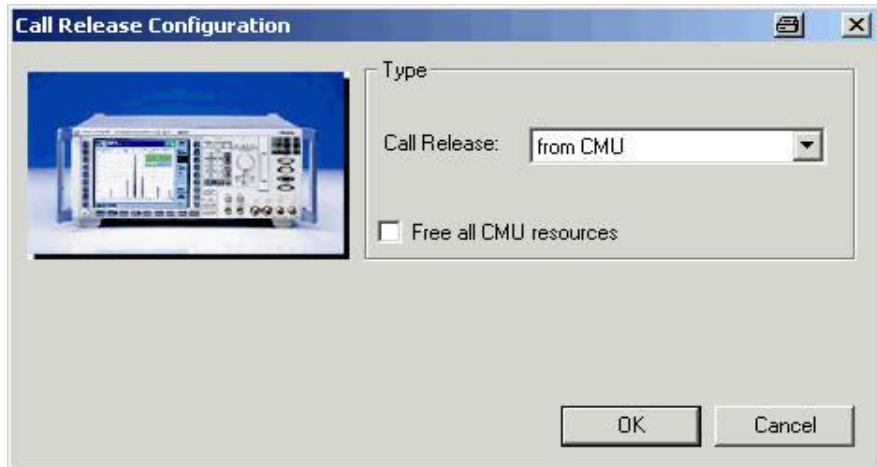

Fig. 32 - Call Release

If the call is not set up or if it has been terminated, the following message window will be displayed (Fig. 33). This query is also performed by all other modules (except for **Call Setup**).

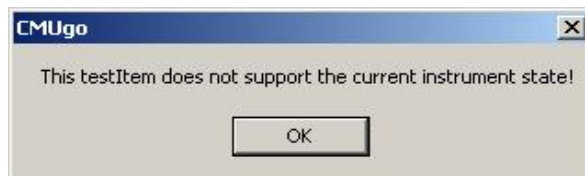

Fig. 33 – Message: no connection

Fig. 34 shows the **Call Release** entry in the test report.



Fig. 34 - Call Release report

## **GSM Testset module**

The **GSM Testset** module provides the easiest means of performing RX and TX measurements with GMSK modulation as quickly as possible. Only additional measurements such as power versus time measurements for multislot or also 8SPK measurements are performed with additional modules.

Changes in the active connection can be made in the top left-hand section. Being able to perform dual-band handover is of particular importance, i.e. you can change the TCH to another band. To do this, you must select a band under **Network** that differs from the one in the previous module.

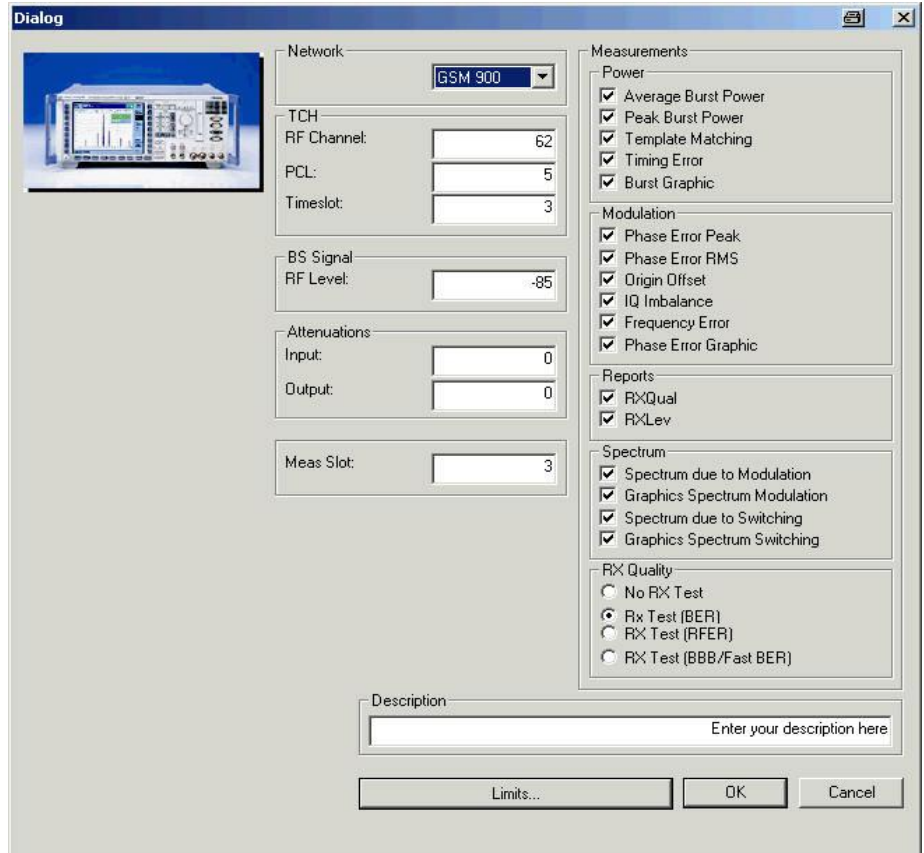

Fig. 35 - GSM Testset

The timeslot to be measured is set using **Meas Slot**.

The individual measurements can be selected from the various sections. Where possible, CMUgo combines the **Power** and **Modulation** measurements to form a common measurement (designation in remote mode: POWER:MPR). To allow this, measurements must be selected under **Power** and **Modulation**. However, **Origin Offset** and/or **IQ Imbalance** must not be selected under **Modulation**. Additionally, graphics can be output for each measurement. If both spectrum measurements are activated (**Spectrum due to Modulation** and **Spectrum due to Switching**), the combined spectrum measurement is used (designation in remote mode: SPECTrum:MSW). Once again, the output of graphics can be activated in each case. All measurements are performed simultaneously to the extent possible in order to save time (see the **Demo** mode or **GSM Testset** in the Appendix).

Clicking the **Limits** button opens the dialog box shown in Fig. 36.

Fig. 36 - GSM Testset: limits

The parameters for the TX measurements are set in the top left-hand section. First, the desired number of TX bursts must be set under **TX Averaging (Bursts)**. The power limits (**Power Upper Limit** and **Power Lower Limit**), the **Max Timing Error** and the various parameters for the modulation measurement can also be set here. Furthermore, you can activate **Decoding with guard and tail bits** and choose between **Average** and **Maximum**.

The top right-hand section is reserved for RX measurements. The RX measurement limits and the number of the frames to be measured are entered in this section. Moreover, you can activate the **Confidence** mode.

The **Spectrum** section (bottom) is reserved for the two spectrum measurements. Note that it allows you to set the offsets defined by the specification and the number of bursts (**No of Bursts**) for each of the two measurements. Additionally, you can activate and enter four variable offsets (**Var. Meas Point 1** to **Var. Meas Point 4**). The **Slot Count** parameter refers to the **due to Switching** measurement for multislot measurements.

Fig. 37 , Fig. 38 and Fig. 39 show the test report entries.

## GSM with R&S CMU and CMUgo

GSM 900, Channel 62, PCL 5, Timeslot: 3, BS RF Level -85.0 dBm, Attenuation (In/Out) 0.0 dB / 0.0 dB, Meas. Slot: 3

Decoding for modulation: Standard, BER Synch time: 0.20 s

Average Power: 10 Bursts	31.00 dBm	35.00 dBm	31.80 dBm	✓
Peak Burst Power: 10 Bursts	31.00 dBm	35.00 dBm	32.27 dBm	✓
Power Time Template: 10 Bursts			passed	✓
Timing Error: 10 Bursts	-2.00 Bit	2.00 Bit	1.55 Bit	✓
Phase Error Peak: 10 Bursts	-20.00 °	20.00 °	-4.33 °	✓
Phase Error RMS: 10 Bursts		5.00 °	-4.60 °	✓
Origin Offset: 10 Bursts		-20.00 dB	-7.29 dB	✓
IQ Imbalance: 10 Bursts		-20.00 dB	-15.33 dB	✓
Frequency Error: 10 Bursts	-90.00 Hz	90.00 Hz	44.95 Hz	✓
RX Qual:		1	0	✓
RX Lev:	23	27	26	✓
Spectrum due to Switching:			passed	✓
Spectrum Switching: @ - 0.6 MHz			-84.62 dBm	✓
Spectrum Switching: @ - 0.4 MHz			-32.72 dBm	✓
Spectrum Switching: @ 0.4 MHz			-73.42 dBm	✓
Spectrum Switching: @ 0.6 MHz			-53.24 dBm	✓
Spectrum due to Modulation:			passed	✓
Spectrum Modulation: @ - 0.6 MHz			-21.96 dBc	✓
Spectrum Modulation: @ - 0.4 MHz			-60.44 dBc	✓
Spectrum Reference Power: @ 0 MHz			20.00 dBm	✓
Spectrum Modulation: @ 0.4 MHz			-59.77 dBc	✓
Spectrum Modulation: @ 0.6 MHz			-34.17 dBc	✓
BBB (Fast BER) 88 Frames		0.20 %	0.07 %	✓

Fig. 37 – Testset report

### Annex: Spectrum due to Modulation

PCL: 5, Channel: 62, Reference Power: 21.8 dBm

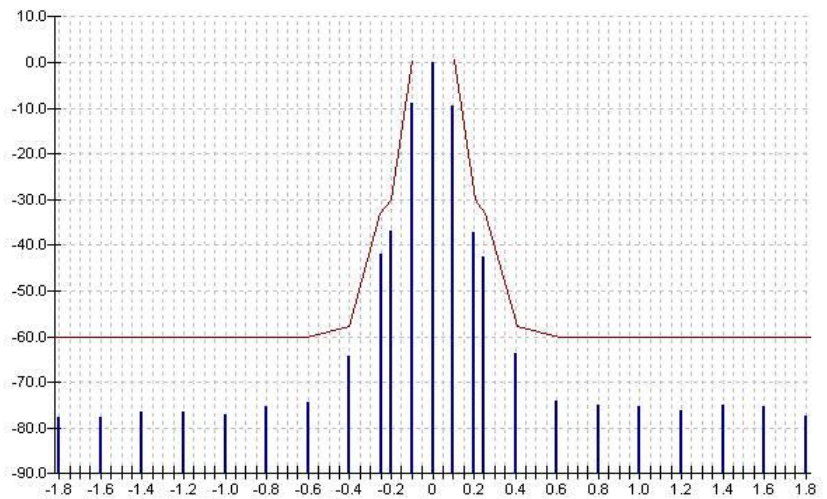

Fig. 38 - Spectrum due to modulation (graph)

## Annex: Spectrum due to Switching

PCL: 5, Channel: 62, Reference Power: 0.0 dBm

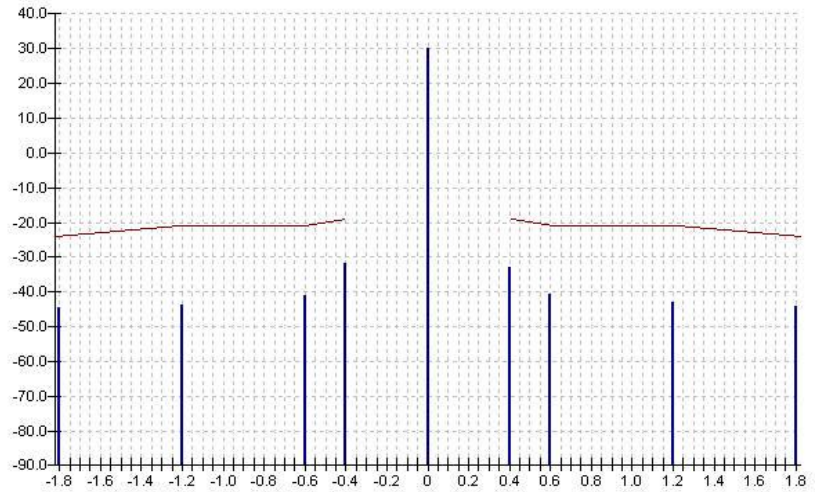

Fig. 39 - Spectrum due to switching (graph)

## GSM Call Edge module

The **GSM Call Edge** module is basically the same as the **GSM Testset** module, except that the measurements are performed with 8PSK modulation and without any RX measurements (Fig. 40).

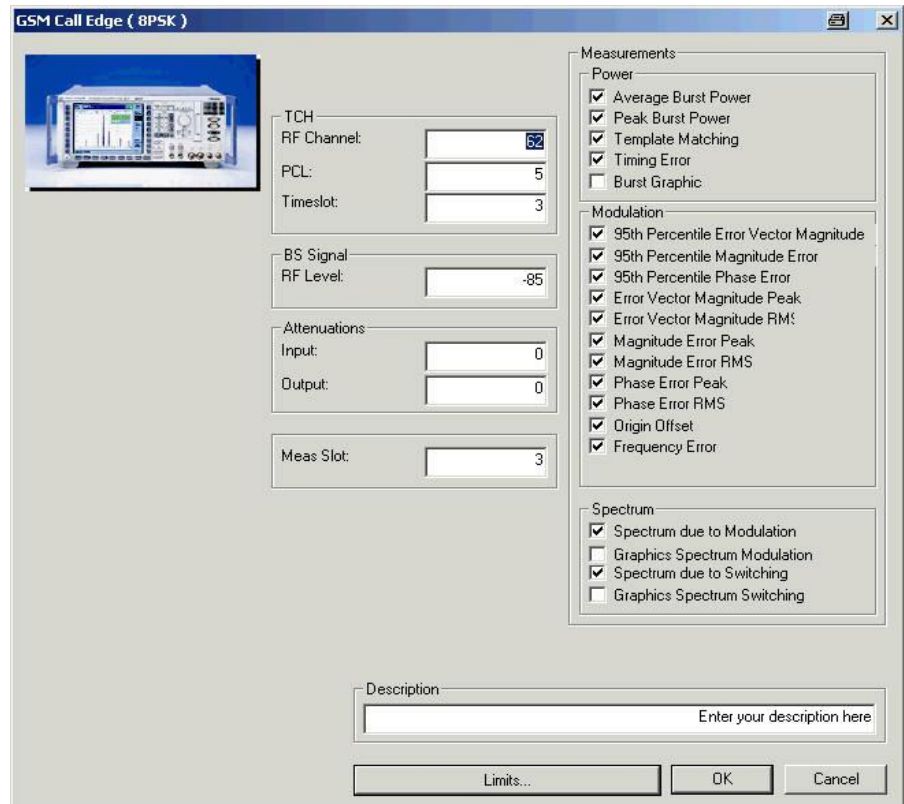

Fig. 40 - GSM Call Edge



The timeslot to be measured is set using **Meas Slot**.

The individual measurements can be selected in the various sections. Additionally, graphs can be output for each measurement. If both spectrum measurements are activated (**Spectrum due to Modulation** and **Spectrum due to Switching**), the combined spectrum measurement is used (designation in remote mode: SPECTrum:MSW). Once again, the output can be activated in each case.

Clicking the **Limits** button opens the dialog box shown in Fig. 41.

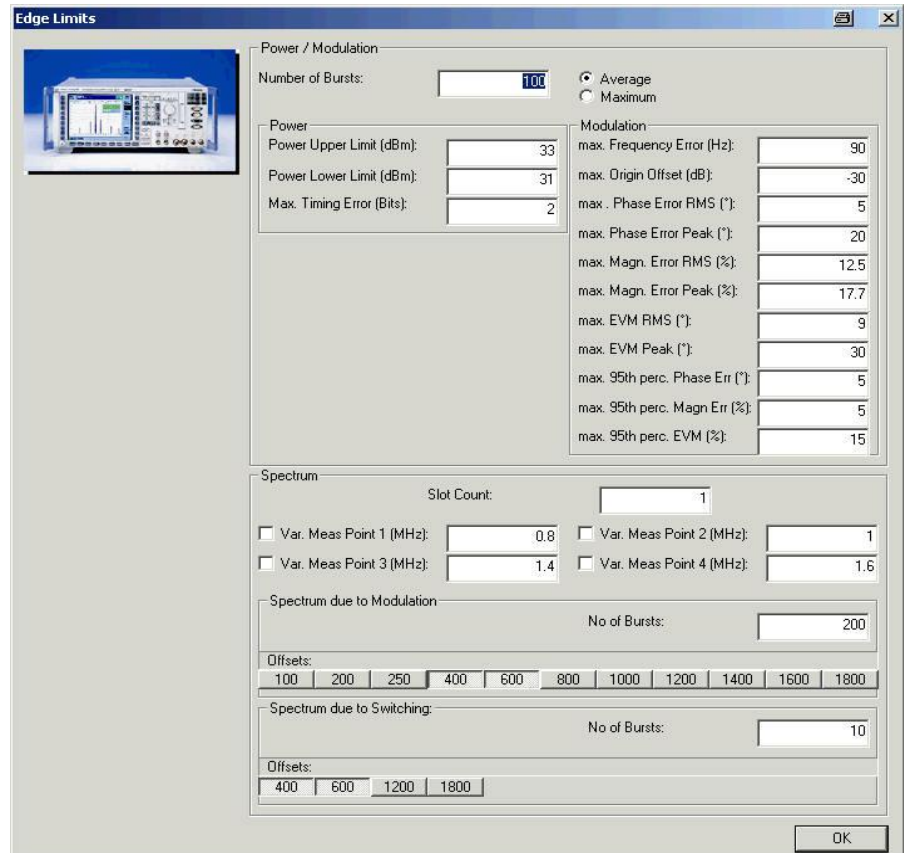

Fig. 41 - GSM Call Edge Limits

First, set the desired number of TX bursts under **No of Bursts** in the **Power/Modulation** section (top). The power limits (**Power Upper Limit** and **Power Lower Limit**), the **Max Timing Error** and the various parameters for the modulation measurement can also be set here. You can also choose between **Average** and **Maximum**.

The **Spectrum** section (bottom) is reserved for the two spectrum measurements. Note that it allows you to set the offsets defined by the specification and the number of bursts (**No of Bursts**) for each of the two measurements. Additionally, you can activate and enter four variable offsets (**Var. Meas. Point 1** to **Var. Meas. Point 4**). The **Slot Count** parameter refers to the **due to Switching** measurement for multislot measurements.

Fig. 42 shows the report; the report for spectrum measurements is identical to that for **GSM Testset**.

## GSM with R&S CMU and CMUgo

Average Power (8PSK): 100 Bursts	31.00 dBm	33.00 dBm	31.00 dBm	✓
Peak Burst Power (8PSK): 100 Bursts	31.00 dBm	33.00 dBm	32.34 dBm	✓
Power Time Template (8PSK): 100 Bursts			passed	✓
Timing Error (8PSK): 100 Bursts	-2.00 Bit	2.00 Bit	-0.89 Bit	✓
95th percentile EVM (8PSK): 100 Bursts	-15.00 %	15.00 %	-6.35 %	✓
95th percentile Magnitude Error (8PSK): 100 Bursts	-5.00 %	5.00 %	1.26 %	✓
95th percentile Phase Error (8PSK): 100 Bursts	-5.00 °	5.00 °	4.91 °	✓
EVM Peak (8PSK): 100 Bursts	-30.00 %	30.00 %	3.80 %	✓
EVM RMS (8PSK): 100 Bursts	-9.00 %	9.00 %	-6.54 %	✓
Magnitude Error Peak (8PSK): 100 Bursts	-17.70 %	17.70 %	8.25 %	✓
Magnitude Error RMS (8PSK): 100 Bursts	-12.50 %	12.50 %	-5.45 %	✓
Phase Error Peak (8PSK): 100 Bursts	-20.00 °	20.00 °	14.19 °	✓
Phase Error RMS (8PSK): 100 Bursts	-5.00 °	5.00 °	-0.68 °	✓
Origin Offset (8PSK): 100 Bursts		-30.00 dB	-79.90 dB	✓
Frequency Error (8PSK): 100 Bursts	-90.00 Hz	90.00 Hz	53.33 Hz	✓
Spectrum due to Switching (8PSK):			passed	✓
Spectrum due to Modulation (8PSK):			passed	✓

Fig. 42 - Call Edge report

## GSM Multislot Test module

The **Multislot Test** module allows you to measure the multislot power (Fig. 43).

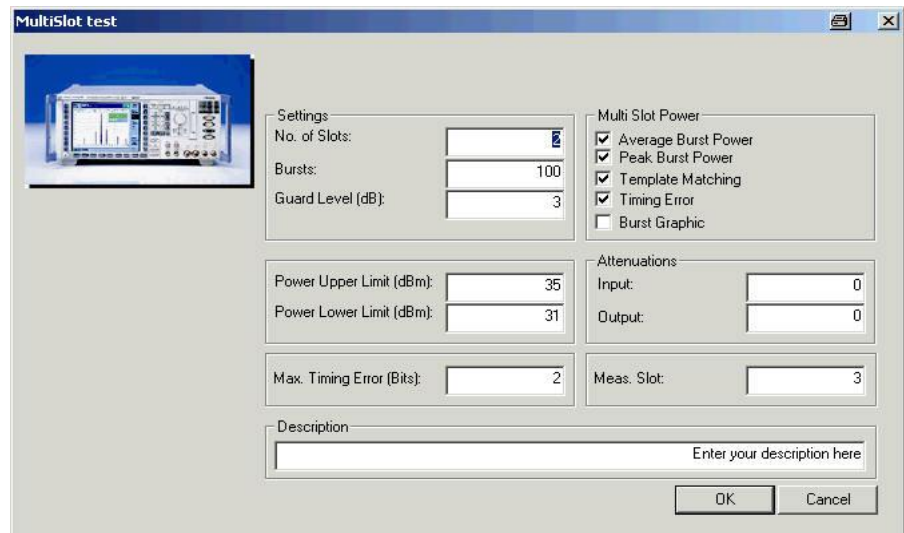

Fig. 43 - GSM Multislot Test

The number of timeslots to be measured (**No of Slots**), the number of bursts and the guard level can be set in the **Settings** section. The limits (**Power Upper Limit** and **Power Lower Limit**), **Max. Timing Error**, the attenuations and the timeslot to be measured can also be set. The measurements to be displayed must then be selected in the **Multislot Power** section.

Fig. 44 shows a typical report entry. If **Burst Graphic** is enabled, a graph is generated (Fig. 45).

## GSM with R&S CMU and CMUgo

Number of Slots: 4, Guard Level (dB): 3.0				
Average Power: Slot 0, 100 Bursts	31.00 dBm	35.00 dBm	18.49 dBm	-
Average Power: Slot -1, 100 Bursts	31.00 dBm	35.00 dBm	-41.25 dBm	-
Average Power: Slot +1, 100 Bursts	31.00 dBm	35.00 dBm	-41.06 dBm	-
Average Power: Slot +2, 100 Bursts	31.00 dBm	35.00 dBm	-40.86 dBm	-
Peak Burst Power: Slot 0, 100 Bursts	31.00 dBm	35.00 dBm	21.51 dBm	-
Peak Burst Power: Slot -1, 100 Bursts	31.00 dBm	35.00 dBm	-31.68 dBm	-
Peak Burst Power: Slot +1, 100 Bursts	31.00 dBm	35.00 dBm	-32.01 dBm	-
Peak Burst Power: Slot +2, 100 Bursts	31.00 dBm	35.00 dBm	-33.45 dBm	-
Power Time Template: Slot 0, 100 Bursts			passed	✓
Power Time Template: Slot -1, 100 Bursts			passed	✓
Power Time Template: Slot +1, 100 Bursts			passed	✓
Power Time Template: Slot +2, 100 Bursts			passed	✓
Timing Error: Slot 0, 100 Bursts	-2.00 Bit	2.00 Bit	0.00 Bit	✓
Timing Error: Slot -1, 100 Bursts	-2.00 Bit	2.00 Bit	0.50 Bit	✓
Timing Error: Slot +1, 100 Bursts	-2.00 Bit	2.00 Bit	0.50 Bit	✓
Timing Error: Slot +2, 100 Bursts	-2.00 Bit	2.00 Bit	0.50 Bit	✓

Fig. 44 – Multislot Test report (table)

### Annex: Power Graphic

Guard Level (dB): 3.0, Number of Slots: 4

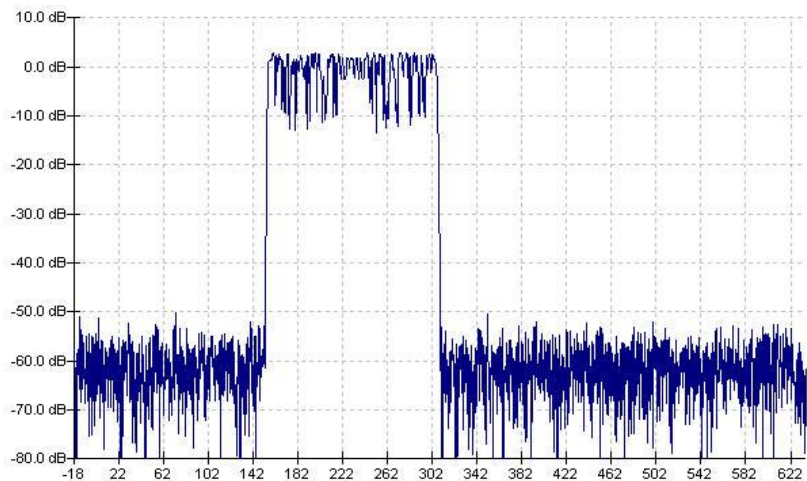

Fig. 45 – Multislot Test report (graph)

## GSM Audio Setting module

The **GSM Audio Setting** module does not perform any measurements. Instead, it is simply used to enter correct settings in the uplink or downlink (Fig. 46).

## GSM with R&S CMU and CMUgo

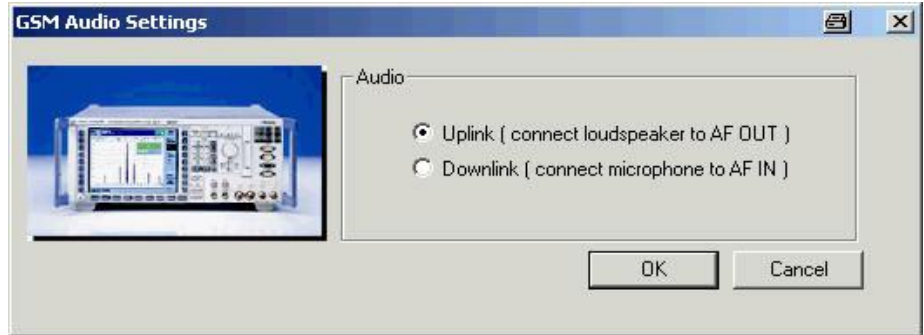

Fig. 46 - Audio setting

For uplink and downlink settings, see page 13.

Fig. 47 shows an entry in the test report.

*Audio Uplink*

Fig. 47 - Audio Setting report

The actual measurements are performed with the **Audio** module (see Fig. 48). Two modules are available for the two channels of the **Audio** option (B41).

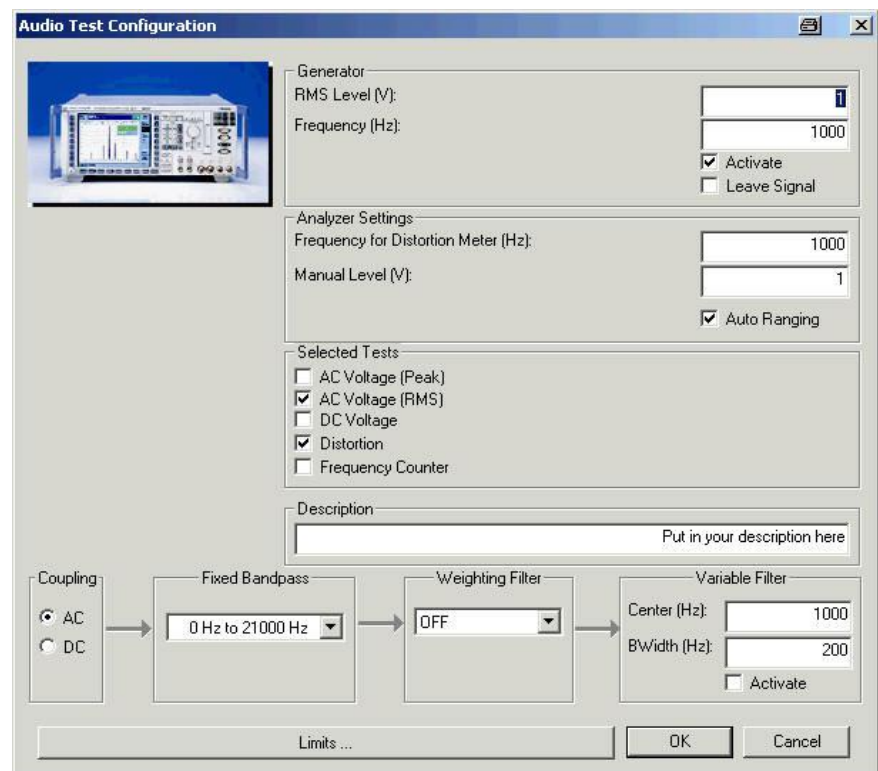

Fig. 48 - Audio test

An **Audio** module consists of a generator and an analyzer. The level and the frequency can be set under **Generator** (upper section). Moreover, you have to switch on the generator (**Activate**). In the middle section, you can select the measurements to be displayed. In the lower section, you can set various filters. Clicking the **Limits** button opens the dialog box shown in Fig. 49. Fig. 50 shows a test report entry

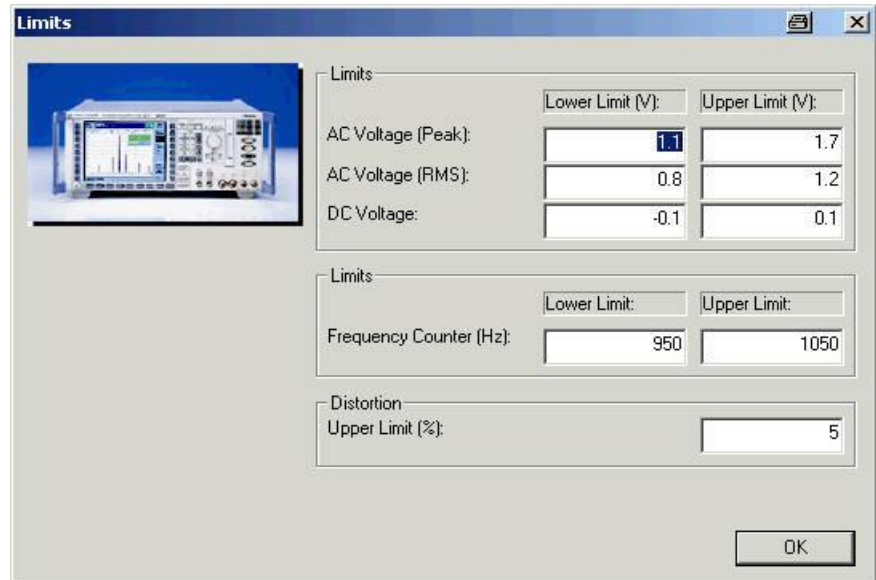

Fig. 49 - Audio test limits

*Audio Generator: Frequency 1000.0 Hz, RMS Level 1.0 V*

*Analyzer Setting: AC Coupled*

*Analyzer Filters: Fixed Bandpass 0 Hz to 21000 Hz, Weighting: off, Variable: off*

<b>AC Voltage (RMS):</b>	0.80 V	1.20 V	1.09 V	✓
<b>Distortion: (at Frequency 1000.0 Hz)</b>		5.00 %	0.93 %	✓

Fig. 50 - Audio test report

## GSM BER Search module

The **GSM BER Search** module determines the sensitivity of a receiver for a specific limit value (Fig. 51). To do this, you set the channel, PCL and timeslot under **TCH** and set the attenuation under **Attenuation**. In the **Measurements** section, you set the BER type, the number of Frames and the limit value.

## GSM with R&S CMU and CMUgo

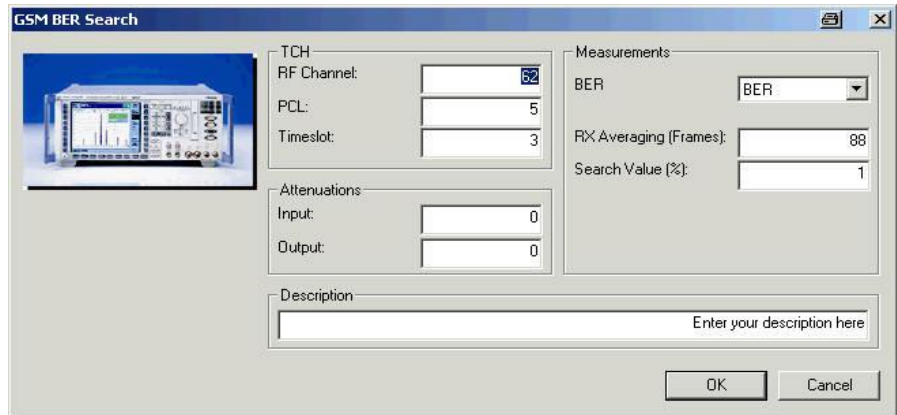

Fig. 51 - BER Search

Start with a few frames using large level steps. Later approach the limit with smaller steps and more frames. Fig. 52 shows the test report entry.

*Channel 62, PCL 5, Timeslot: 3, Attenuation (In/Out) 0.0 dB / 0.0 dB, Search Value: 1.0*

**BER Search: 88 Frames**

**-105.10 dBm**

Fig. 52 - BER Search report

## GSM Call AMR module

The **GSM Call AMR** allows you to test the AMR speech coder characteristics of the mobile phone (Fig. 53). To do this, set the start and stop level, step size as well as **Codec** mode under AMR.

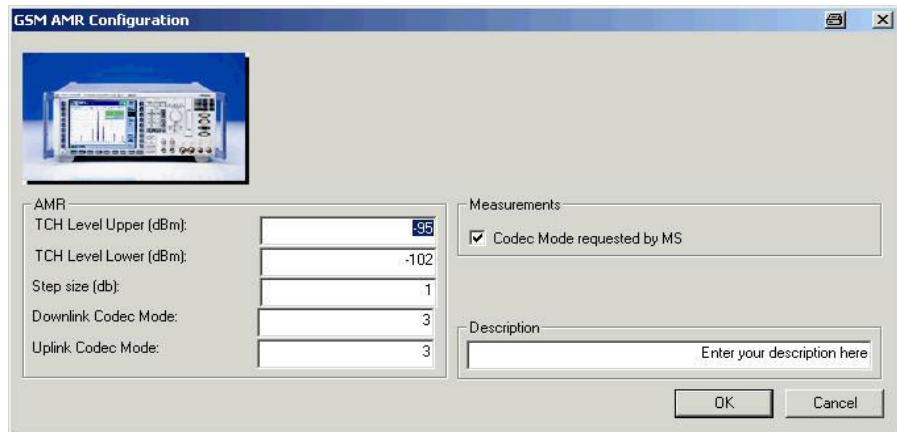

Fig. 53 - Call AMR

CMUgo now reduces the level in the individual steps, and the mobile phone requests a **Codec** mode for each level. This mode is displayed in a table in the report. To include the hysteresis loops, the level is then increased back up to the initial state.



## GSM with R&S CMU and CMUgo

Codec Mode requested by MS: @ -95.0 dBm			2	✓
Codec Mode requested by MS: @ -96.0 dBm			2	✓
Codec Mode requested by MS: @ -97.0 dBm			0	✓
Codec Mode requested by MS: @ -98.0 dBm			1	✓
Codec Mode requested by MS: @ -99.0 dBm			2	✓
Codec Mode requested by MS: @ -100.0 dBm			0	✓
Codec Mode requested by MS: @ -101.0 dBm			1	✓
Codec Mode requested by MS: @ -102.0 dBm			3	✓
Codec Mode requested by MS: @ -102.0 dBm			3	✓
Codec Mode requested by MS: @ -101.0 dBm			0	✓
Codec Mode requested by MS: @ -100.0 dBm			0	✓
Codec Mode requested by MS: @ -99.0 dBm			3	✓
Codec Mode requested by MS: @ -98.0 dBm			0	✓
Codec Mode requested by MS: @ -97.0 dBm			1	✓
Codec Mode requested by MS: @ -96.0 dBm			2	✓
Codec Mode requested by MS: @ -95.0 dBm			3	✓

Fig. 54 – AMR report

## GSM Call Change Multislot module

The **GSM Call Change Multislot** module is used to change call parameters in the multislot mode (Fig. 55). The parameters correspond to those in **Fehler! Verweisquelle konnte nicht gefunden werden.** (see "GSM Call Setup module").

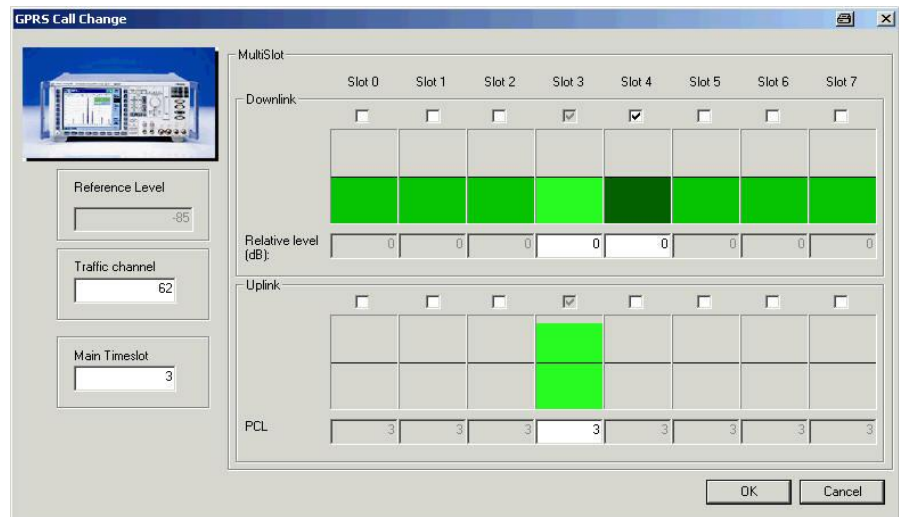

Fig. 55 - Call Change Multislot

Fig. 56 shows the test report entry.

*Downlink (Slot 0..7: Enable, dB): OFF, OFF, OFF, ON, ON, OFF, OFF, OFF, 0.0, 0.0, 0.0, 0.0, 0.0, 0.0, 0.0, 0.0*

*Uplink (Slot 0..7: Enable, PCL): OFF, OFF, OFF, ON, OFF, OFF, OFF, OFF, 3, 3, 3, 3, 3, 3, 3, 3*

*Main Timeslot: 3, Traffic channel: 62*

Fig. 56 - Call Change Multislot report

## GSM Channel Scan module

The **GSM Channel Scan** module is used to perform power measurements across multiple channels (Fig. 57). To do this, you need to set the following parameters in the **TCH** section: **Start Channel**, **Stop Channel**, **PCL** and

## GSM with R&S CMU and CMUgo

**Timeslot.** You also need to set the level and attenuation values. The CMU now performs the power measurements selected under **Measurements** on the Meas. Slot using the number of bursts.

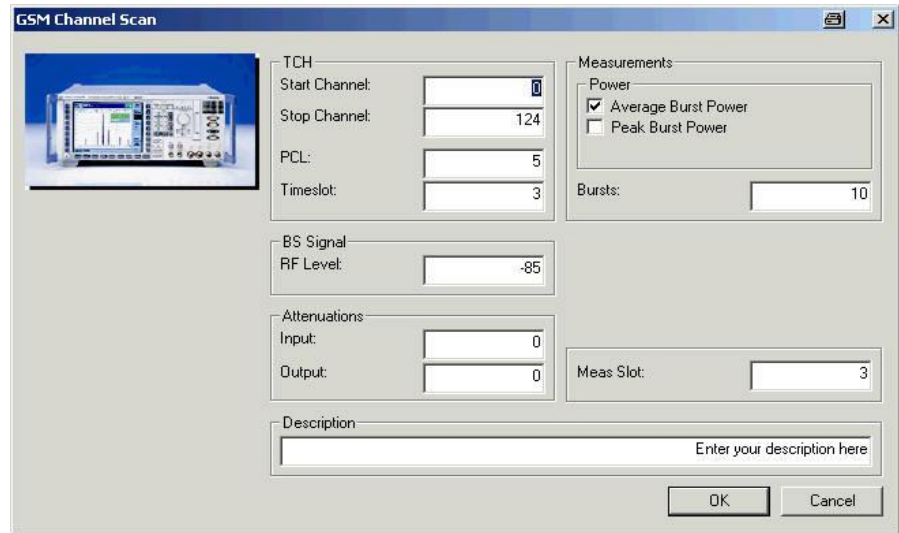

Fig. 57 - Channel Scan

the channels with the maximum and minimum power (Fig. 58) and a graph of all values are output (Fig. 59).

*PCL 5, Timeslot: 3, BS RF Level -85.0 dBm, Attenuation (In/Out) 0.0 dB / 0.0 dB, 10 Bursts, Meas Slot: 3*

<b>Average Power Maximum:</b> @ Channel: 20			30.03 dBm	✓
<b>Average Power Minimum:</b> @ Channel: 10			29.99 dBm	✓

Fig. 58 - Channel Scan report

### Annex: Power Graphic

*PCL: 5, Start Channel: 10, Stop Channel: 20, Average Power: blue, Peak Power: green*

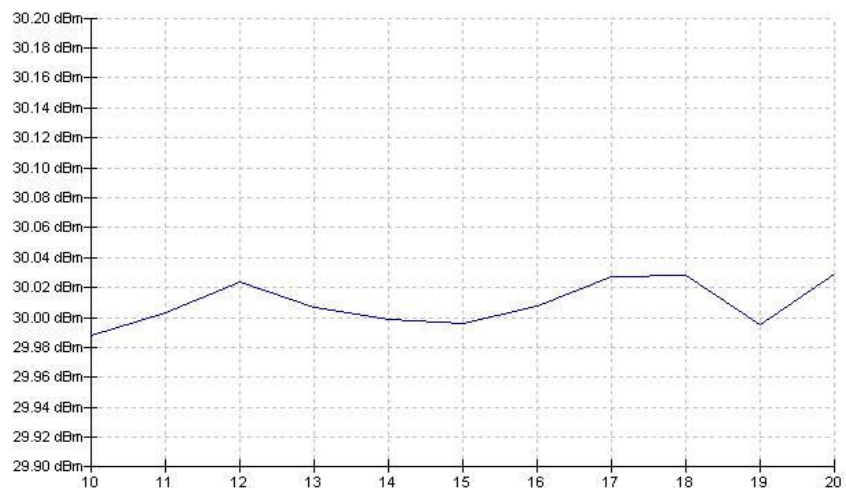

Fig. 59 - Channel Scan graph

## GSM Call Echo Test module

The echo test can only be performed in the voice call (Fig. 60). To do this, you can set the usual parameters under **Traffic Channel TCH** and **Attenuations**.

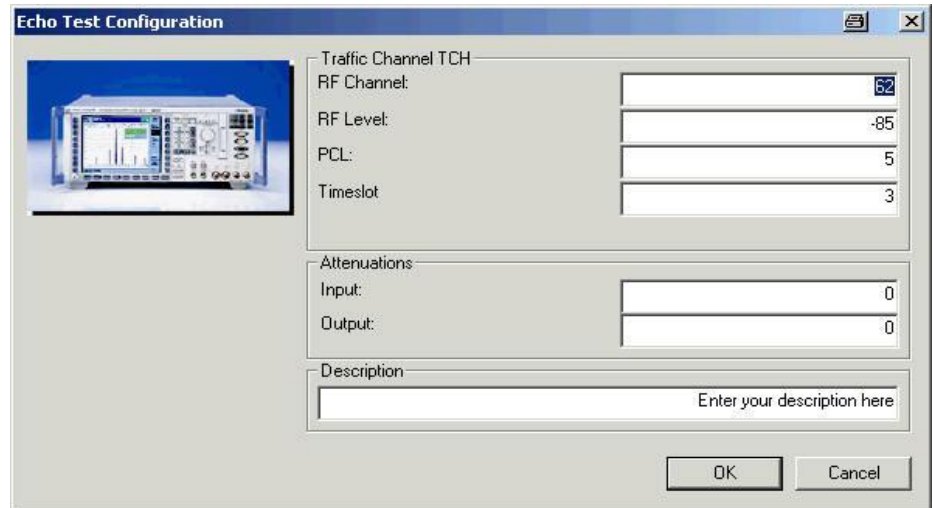

Fig. 60 – Call Echo Test

CMUgo then waits for your entry (Fig. 61).

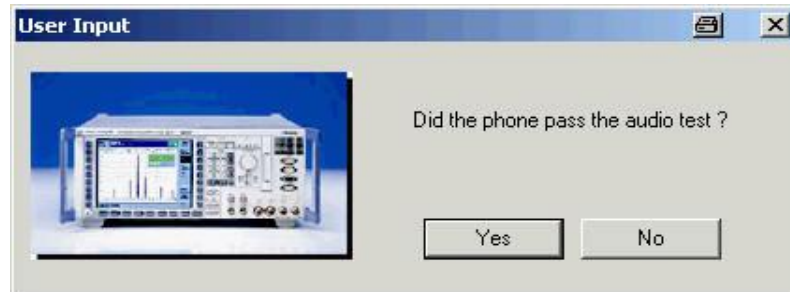

Fig. 61 - User input for Call Echo Test

Fig. 62 shows the test report entry.

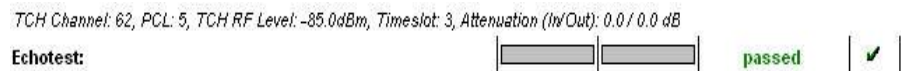

Fig. 62 – Call Echo Test report

## GSM PowerPCL module

The **GSM PowerPCL** module is used to simulate the CMU's power-versus-PCL measurement in CMUgo (Fig. 63). **Fehler! Verweisquelle konnte nicht gefunden werden.** Although this measurement is not required by the specification, it quickly covers all PCLs on three or seven user-selectable channels.

## GSM with R&S CMU and CMUgo

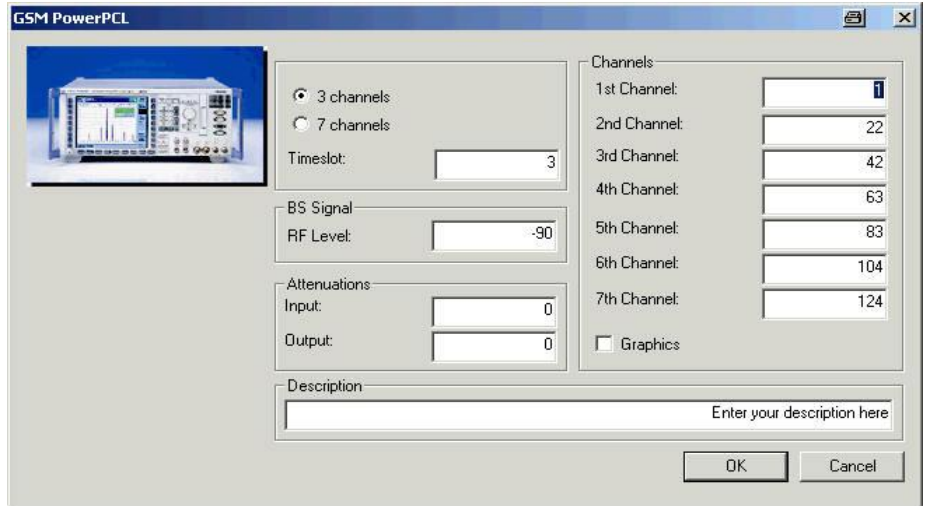

Fig. 63 – PowerPCL

*Timeslot: 3, TCH RF Level: -90.0dBm, Attenuation (In/Out): 0.0 / 0.0 dB*

**Power PCL:**



Fig. 64 – PowerPCL report

### Annex: Power PCL

*Channels: 1, 22, 42*

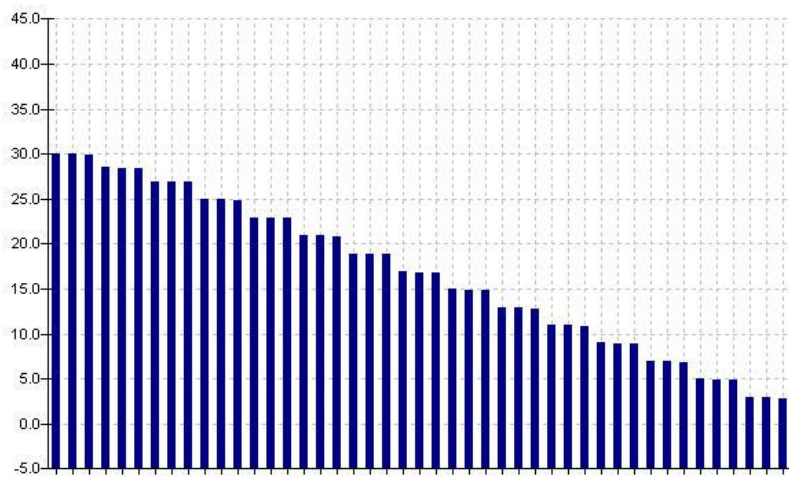

Fig. 1 – PowerPCL graph

## 5 Appendix

### List of Figures

Fig. 1 - Downlink on two channels without option B95 .....	3
Fig. 2 – CMU setup for BS signal without option B95.....	4
Fig. 3 - Downlink on the same channel without option B95.....	4
Fig. 4 - Downlink with option B95 .....	4
Fig. 5 – CMU setup for BS signal with option B95.....	5
Fig. 6 – Analyzer mode.....	6
Fig. 7 – Default state of the CMU .....	6
Fig. 8 - CMU in the synchronized state .....	7
Fig. 9– (E)GPRS states in the CMU .....	7
Fig. 10 – Overview menu.....	8
Fig. 11 - Power vs time measurement.....	9
Fig. 12 – PowerPCL .....	9
Fig. 13 – Modulation .....	10
Fig. 14 - Spectrum due to modulation .....	11
Fig. 15 - Spectrum due to switching .....	11
Fig. 16 – Combined spectrum measurement .....	12
Fig. 17 - Receiver quality.....	13
Fig. 18 - Audio setting: Bit Stream.....	13
Fig. 19 - Audio uplink in the CMU.....	14
Fig. 20 - Audio uplink setting .....	14
Fig. 21 - Audio downlink in the CMU .....	15
Fig. 22 – Audio downlink setting.....	15
Fig. 23 - Audio generator.....	16
Fig. 24 - Audio analyzer.....	16
Fig. 25 – AMR.....	17
Fig. 26 - AMR hysteresis .....	17
Fig. 27 - Call Setup configuration .....	19
Fig. 28 - Call Setup: AT commands .....	20
Fig. 29 - Call Setup: additional configuration.....	20
Fig. 30 - Call Setup: multislot.....	21
Fig. 31 - Call Setup report .....	21
Fig. 32 - Call Release .....	22
Fig. 33 – Message: no connection.....	22

Fig. 34 - Call Release report.....	22
Fig. 35 - GSM Testset .....	23
Fig. 36 - GSM Testset: limits .....	24
Fig. 37 – Testset report .....	25
Fig. 38 - Spectrum due to modulation (graph).....	25
Fig. 39 - Spectrum due to switching (graph) .....	26
Fig. 40 - GSM Call Edge.....	26
Fig. 41 - GSM Call Edge Limits .....	27
Fig. 42 - Call Edge report .....	28
Fig. 43 - GSM Multislot Test.....	28
Fig. 44 – Multislot Test report (table).....	29
Fig. 45 – Multislot Test report (graph) .....	29
Fig. 46 - Audio setting.....	30
Fig. 47 - Audio Setting report.....	30
Fig. 48 - Audio test .....	30
Fig. 49 - Audio test limits .....	31
Fig. 50 - Audio test report .....	31
Fig. 51 - BER Search.....	32
Fig. 52 - BER Search report .....	32
Fig. 53 - Call AMR .....	32
Fig. 54 – AMR report .....	33
Fig. 55 - Call Change Multislot .....	33
Fig. 56 - Call Change Multislot report .....	33
Fig. 57 - Channel Scan.....	34
Fig. 58 - Channel Scan report .....	34
Fig. 59 - Channel Scan graph.....	34
Fig. 60 – Call Echo Test .....	35
Fig. 61 - User input for Call Echo Test .....	35
Fig. 62 – Call Echo Test report.....	35
Fig. 63 – PowerPCL .....	36
Fig. 64 – PowerPCL report.....	36

## **Remote Sequences**

### **GSM Call Setup**

PCL mode and status query:

`LEV:MODE PCL`

`SIGN:STAT?`

Network settings, connector and attenuation:



## ***GSM with R&S CMU and CMUgo***

---

CONF:NETW:NSUP GSM  
CONF:NETW:SMOD:TRAF FRV1  
CONF:NETW:SMOD:BITS PR9  
CONF:RXQ:BITS PR9  
CONF:NETW:IDEN:MCC 1  
CONF:NETW:IDEN:MNC 1  
INP:STAT RF2  
OUTP:STAT RF2  
SENS:CORR:LOSS:INP2 0.0  
SENS:CORR:LOSS:OUTP2 0.0

Base station settings: BCCH channel 30, level -85 dBm, TCH 62, timeslot 3, PCL 15, level -85 dBm:

CONF:BSS:CCH:MODE BATC  
CONF:BSS:CCH:CHAN 30  
CONF:BSS:CCH:LEV -85.0  
CONF:BSS:CHAN 62  
CONF:BSS:MSL:MTIM 3  
CONF:Figure:BSSignal:CSWitched:TCH:SSLot:TIMeslot 3  
CONF:BSS:MSL:LMOD IND  
CONF:MSS:MS:PCL 15  
CONF:BSS:LEV:UTIM -85.0  
CONF:SIGN:SMOD SSL  
CONF:BSS:MSL:SCON:IND OFF,OFF,OFF,ON,OFF,OFF,OFF,OFF,0.0,-20.0,-20.0,0.0,-20.0,-20.0,-20.0,-20.0  
CONF:MSS:MSL:SCON OFF,OFF,OFF,ON,OFF,OFF,OFF,OFF,15,15,15,15,15,15,15,15

Activation of BCCH and status query in loop up to SYNC status:

PROC:SIGN:ACT SON;\*OPC?  
SIGN:STAT?

Call to the mobile phone and status query in loop up to CEST status:

PROC:SIGN:ACT MTC;\*OPC?  
SIGN:STAT?

Query of mobile phone parameters:

MSS:IMSI:MCC?  
MSS:IMSI:MNC?  
MSS:IMSI:MSIN?  
MSS:IMEI:FAC?  
MSS:IMEI:TAC?  
MSS:IMEI:SNR?  
MSS:IMEI:SVN?  
MSS:REV?  
MSS:DNUM?  
MSS:TRAF?  
MSS:POW:CLAS?

### **GSM Call Release**

SIGN:STAT?

PROC:SIGN:ACT CREL

SIGN:STAT?

### **GSM Testset**

Status query, attenuation ( 0 dB ) and BER parameters:

SENS:SIGN:STAT?

SENS:SIGN:PDAT:STAT?

CONF:SIGN:SMOD?

INP:STAT?

SENS:CORR:LOSS:INP2 0.0

SENS:CORR:LOSS:OUTP2 0.0

CONF:RXQ:CONT:HTIM 0,0.20

CONF:RXQ:BER1:CONT:REP NONE,NONE

Changing of call parameters (level -85 dBm, channel 62, timeslot 3, PCL 5), meas. slot 3:

PROC:BSS:TCH:LEV:UTIM?

PROC:BSS:TCH:LEV:UTIM -85.0

PROC:SIGN:CHCC?

PROC:SIGN:CHCC 62,3,5;\*OPC?

CONF:MCON:MSL:MESL 3

Power measurement (singleshot, 10 bursts).

CONF:POW:CONT:REP SING,NONE,NONE

CONF:POW:CONT ARR,10

READ:POW?

FETC:ARR:POW?

Modulation measurement (singleshot, 10 bursts, standard decoding):

CONF:MOD:XPER:CONT:REP SING,NONE,NONE

CONF:MOD:XPER:CONT ARR,10

CONF:MOD:XPER:TIME:DEC STAN

READ:MOD:XPER?

FETC:ARR:MOD:XPER?

Spectrum measurement (modulation: points 4 and 5 ON, 10 bursts, singleshot; switching: points 1 and 2 ON, 10 bursts, combined measurement):

CONF:SPEC:MOD:CONT:MPO1:ENAB OFF

CONF:SPEC:MOD:CONT:MPO2:ENAB OFF

CONF:SPEC:MOD:CONT:MPO3:ENAB OFF

CONF:SPEC:MOD:CONT:MPO4:ENAB ON

CONF:SPEC:MOD:CONT:MPO5:ENAB ON

CONF:SPEC:MOD:CONT:MPO6:ENAB OFF

CONF:SPEC:MOD:CONT:MPO7:ENAB OFF

CONF:SPEC:MOD:CONT:MPO8:ENAB OFF

## ***GSM with R&S CMU and CMUgo***

---

CONF:SPEC:MOD:CONT:MPO9:ENAB OFF  
CONF:SPEC:MOD:CONT:MPO10:ENAB OFF  
CONF:SPEC:MOD:CONT:MPO11:ENAB OFF  
CONF:SPEC:MOD:CONT ARR,10  
CONF:SPEC:MOD:CONT:REP SING,NONE,NONE  
CONF:SPEC:MSW:CONT ARR  
CONF:SPEC:MSW:CONT:REP SING,NONE,NONE  
CONF:SPEC:SWIT:CONT:MPO1:ENAB ON  
CONF:SPEC:SWIT:CONT:MPO2:ENAB ON  
CONF:SPEC:SWIT:CONT:MPO3:ENAB OFF  
CONF:SPEC:SWIT:CONT:MPO4:ENAB OFF  
CONF:SPEC:SWIT:CONT ARR,10  
CONF:SPEC:SWIT:CONT:REP SING,NONE,NONE  
CONF:SPEC:SWIT:NOSL 1  
INIT:SPEC:MSW  
FETC:SPEC:MSW?  
FETC:ARR:SPEC:MSW?

### **GSM Call Edge**

The spectrum measurements are identical to those for GSM testset.

Status query, attenuation (0 dB), meas. slot (3):

SENS:SIGN:STAT?  
SENS:SIGN:PDAT:STAT?  
CONF:SIGN:SMOD?  
INP:STAT?  
PROC:SIGN:PDAT:TCH:MSL:SCON?  
SENS:CORR:LOSS:INP2 0.0  
SENS:CORR:LOSS:OUTP2 0.0  
CONF:MCON:MSL:MESL 3

Edge power measurement (filter 600 kHz, 10 bursts, singleshot):

CONF:POW:EPSK:FILT B600  
CONF:POW:EPSK:CONT ARR,100  
CONF:POW:EPSK:CONT:REP SING,NONE,NONE  
INIT:POW:EPSK  
FETC:POW:EPSK?

Edge modulation measurement (100 bursts, singleshot):

CONF:MOD:OVER:EPSK:CONT ARR,100  
CONF:MOD:OVER:EPSK:CONT:REP SING,NONE,NONE  
INIT:MOD:OVER:EPSK  
FETC:MOD:OVER:EPSK?

### **GSM Multislot Test**

Status query

SENS:SIGN:STAT?

## ***GSM with R&S CMU and CMUgo***

---

SENS:SIGN:PDAT:STAT?

Multislot measurement (meas. slot 3, singleshot, 100 bursts, 4 slots, ANY modulation, filter 500 kHz, guard level 3):

CONF:MSS:MCON:MESL 3

CONF:POW:MSL:CONT:REP SING,NONE,NONE

CONF:POW:MSL:CONT ARR,100

CONF:POW:MSL:SCO 4

CONF:POW:MSL:MVI ANY,ANY,ANY,ANY

CONF:POW:MSL:FILT G500

CONF:POW:MSL:LIM:LINE:GLEV 3.0

INIT:POW:MSL

FETC:POW:MSL?

### **GSM Audio Settings**

Status query, bit stream handset, speech encoder handset, speech decoder analyzer:

SENS:SIGN:STAT?

PROC:BSS:BITS HAND

ROUT:SPEN HAND

ROUT:SPD ANAL

\*OPC?

### **GSM AMR**

Status and traffic query:

SENS:SIGN:STAT?

CONF:NETW:SMOD:TRAF?

Uplink and downlink code setting:

PROC:NETW:AMR:FRAT:DLCM CM3

PROC:NETW:AMR:FRAT:ULCM CM3

Routine: level setting, requested code query:

PROC:BSS:LEV:UTIM -95.0;\*OPC?

MSS:AMR:FRAT:DLCM?

PROC:BSS:LEV:UTIM -96.0;\*OPC?

MSS:AMR:FRAT:DLCM?

PROC:BSS:LEV:UTIM -97.0;\*OPC?

MSS:AMR:FRAT:DLCM?

PROC:BSS:LEV:UTIM -98.0;\*OPC?

MSS:AMR:FRAT:DLCM?

PROC:BSS:LEV:UTIM -99.0;\*OPC?

MSS:AMR:FRAT:DLCM?

PROC:BSS:LEV:UTIM -100.0;\*OPC?

MSS:AMR:FRAT:DLCM?

PROC:BSS:LEV:UTIM -101.0;\*OPC?

MSS:AMR:FRAT:DLCM?

PROC:BSS:LEV:UTIM -102.0;\*OPC?

MSS:AMR:FRAT:DLCM?  
PROC:BSS:LEV:UTIM -102.0;\*OPC?  
MSS:AMR:FRAT:DLCM?  
PROC:BSS:LEV:UTIM -101.0;\*OPC?  
MSS:AMR:FRAT:DLCM?  
PROC:BSS:LEV:UTIM -100.0;\*OPC?  
MSS:AMR:FRAT:DLCM?  
PROC:BSS:LEV:UTIM -99.0;\*OPC?  
MSS:AMR:FRAT:DLCM?  
PROC:BSS:LEV:UTIM -98.0;\*OPC?  
MSS:AMR:FRAT:DLCM?  
PROC:BSS:LEV:UTIM -97.0;\*OPC?  
MSS:AMR:FRAT:DLCM?  
PROC:BSS:LEV:UTIM -96.0;\*OPC?  
MSS:AMR:FRAT:DLCM?  
PROC:BSS:LEV:UTIM -95.0;\*OPC?  
MSS:AMR:FRAT:DLCM?

### **GSM Change Multislot**

Querying

SENS:SIGN:STAT?  
CONF:BSS:CCH:MODE?  
CONF:SIGN:SMOD?

Setting of multislot and channel:

PROC:SIGN:MSL:SCON  
3,OFF,OFF,OFF,ON,ON,OFF,OFF,OFF,0,0,0,0,0,0,0,0,0,0,0,0,0,0,OFF,OFF,OFF,ON,OF  
F,OFF,OFF,OFF,3,3,3,3,3,3,3,3  
PROC:SIGN:CHAN 62;\*OPC?

### **GSM Channel Scan**

Querying

SENS:SIGN:STAT?  
CONF:SIGN:SMOD?  
INP:STAT?  
SENS:CORR:LOSS:INP2 0.0  
SENS:CORR:LOSS:OUTP2 0.0

Setting of parameters: level -85 dBm, timeslot 3, PCL 5:

PROC:BSS:TCH:LEV:UTIM?  
PROC:BSS:TCH:LEV:UTIM -85.0  
PROC:SIGN:TCH:TIM?  
PROC:SIGN:TCH:TIM 3  
PROC:SIGN:MS:PCL?  
PROC:SIGN:MS:PCL 5  
CONF:BSS:CCH:CHAN?  
CONF:MCON:MSL:MESL 3

## ***GSM with R&S CMU and CMUgo***

---

Routine: Measuring and channel change, for example:

```
CONF:POW:MPR:CONT:REP SING,NONE,NONE
CONF:POW:MPR:CONT SCAL,10
PROC:SIGN:CSW:TCH:CHAN 10;*OPC?
CONF:BSS:CCH:CHAN?
CONF:MCON:MSL:MESL 3
CONF:POW:MPR:CONT:REP SING,NONE,NONE
CONF:POW:MPR:CONT SCAL,10
INIT:POW:MPR
FETC:POW:MPR?
PROC:SIGN:CSW:TCH:CHAN 11;*OPC?
CONF:BSS:CCH:CHAN?
CONF:MCON:MSL:MESL 3
CONF:POW:MPR:CONT:REP SING,NONE,NONE
CONF:POW:MPR:CONT SCAL,10
INIT:POW:MPR
FETC:POW:MPR?
PROC:SIGN:CSW:TCH:CHAN 12;*OPC?
CONF:BSS:CCH:CHAN?
CONF:MCON:MSL:MESL 3
CONF:POW:MPR:CONT:REP SING,NONE,NONE
CONF:POW:MPR:CONT SCAL,10
INIT:POW:MPR
FETC:POW:MPR?
```

### **GSM Call Echo Test**

```
SIGN:STAT?
INP:STAT?
SENS:CORR:LOSS:INP2 0.0
SENS:CORR:LOSS:OUTP2 0.0
PROC:BSS:TCH:LEV:UTIM?
PROC:BSS:TCH:LEV:UTIM -85.0
PROC:SIGN:TCH:TIM?
PROC:SIGN:TCH:TIM 3
PROC:SIGN:TCH:CHAN?
PROC:SIGN:TCH:CHAN 62
PROC:SIGN:MS:PCL?
PROC:SIGN:MS:PCL
```

### **GSM PowerPCL**

Querying and settings:

```
SENS:SIGN:STAT?
INP:STAT?
SENS:CORR:LOSS:INP2 0.0
SENS:CORR:LOSS:OUTP2 0.0
```



PROC:BSS:TCH:LEV:UTIM?

PROC:BSS:TCH:LEV:UTIM -90.0

PROC:SIGN:TCH:TIM?

PROC:SIGN:TCH:TIM 3

Measurement settings: 3 channels: 1, 22 and 42:

CONF:POW:PCL:CONT:REP SING,NONE,NONE

CONF:POW:PCL:CCO C3

CONF:POW:PCL:CHAN 1,22,42

INIT:POW:PCL

FETC:POW:PCL?

CALC:POW:PCL:LIM:MATC?

### **Abbreviations**

CS	Coding Scheme
EDGE	Enhanced Data Rates for GSM Modulation
EGPRS	Enhanced General Packet Radio Service
GPRS	General Packet Radio Service
HSCSD	High Speed Circuit Switched Data
MCS	Modulation and Coding Scheme
RLC	Radio Link Control
TBF	Temporary Block Flow
USF	Uplink State Flag

### **References**

[1] Rohde & Schwarz: **Manual for CMUgo Windows Application (V1.00)**, 12/2002, 1136.3971.00

[2] Rohde & Schwarz: **Operating Manual for Software Options K20, K21, K22, K23, K24, K42, K43** (1115.5900.02, 1115.6007.02, 1115.6107.02, 1115.6207.02, 1115.6307.02, 1115.4691.02, 1115.6907.02) *Revision 1115.6088.12-13-*)

[3] Rohde & Schwarz: Application Note: **(E)GPRS Measurements with the R&S CMU200 and CMUgo**

### **Additional information**

Please send any comments or suggestions concerning this Application Note to [CMUApplication@rsd.rohde-schwarz.com](mailto:CMUApplication@rsd.rohde-schwarz.com).

## **GSM with R&S CMU and CMUgo**

---

### Ordering information

#### **Communication Tester**

R&S CMU200		1100.0008.02
CMU-B21 <sup>(1)</sup>	Versatile signalling unit	1100.5200.02
CMU-B21v14 <sup>(1)</sup>	Universal signalling unit	1100.5200.14
Option B41 (optional)	Audio generator and analyzer	1100.5300.02
CMU-K20	SW options for GSM400	1115.5900.02
CMU-K21	SW options for GSM900	1115.6007.02
CMU-K22	SW options for GSM1800	1115.6107.02
CMU-K23	SW options for GSM1900	1115.6207.02
CMU-K24	SW options for GSM850	1115.6307.02
CMU-K42	SW GPRS extension for GSM	1115.4691.02
CMU-K43	SW EGPRS extension for GSM	1115.6907.02

<sup>(1)</sup> CMU-B21 or CMU-B21v14 with CMU-B54v14 is required.



# **ROHDE & SCHWARZ**

ROHDE & SCHWARZ GmbH & Co. KG · Mühlhofstraße 15 · D-81671 München · Postfach 80 14 69 · D-81614 München ·  
Tel (089) 4129 -0 · Fax (089) 4129 - 13777 · Internet: <http://www.rohde-schwarz.com>

*This Application Note and the supplied programs may only be used subject to observance of the conditions of use set forth in the download area of the Rohde & Schwarz website.*